

Certification Test Report

**FCC ID: VSFMS2
IC: 7980A-MS2**

**FCC Rule Part: 15.247
IC Radio Standards Specification: RSS-247**

ACS Report Number: 15-2133.W06.1A

Manufacturer: Juniper Systems, Inc.
Model(s): MS2G and MS2GC

Test Begin Date: **December 10, 2015**
Test End Date: **March 4, 2016**

Report Issue Date: March 4, 2016



FOR THE SCOPE OF ACCREDITATION UNDER CERTIFICATE NUMBER AT-1533

This report must not be used by the client to claim product certification, approval, or endorsement by ANAB, ANSI, or any agency of the Federal Government.

Project Manager:

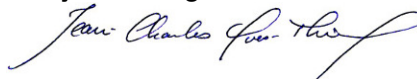
A handwritten signature in black ink that reads "Thierry Jean-Charles".

**Thierry Jean-Charles
EMC Engineer
Advanced Compliance Solutions, Inc.**

This test report shall not be reproduced except in full. This report may be reproduced in part with prior written consent of ACS, Inc. The results contained in this report are representative of the sample(s) submitted for evaluation.

This report contains 66 pages

TABLE OF CONTENTS

1	GENERAL	3
1.1	Purpose	3
1.2	Product Description.....	3
1.3	Manufacturer Information	3
1.4	Test Methodology and Considerations	4
2	TEST FACILITIES	5
2.1	Location.....	5
2.2	Laboratory Accreditations/Recognitions/Certifications	5
2.3	Radiated & Conducted Emissions Test Site Description	6
3	APPLICABLE STANDARD REFERENCES.....	8
4	LIST OF TEST EQUIPMENT.....	9
5	SUPPORT EQUIPMENT	10
6	EQUIPMENT UNDER TEST SETUP BLOCK DIAGRAM	10
7	SUMMARY OF TESTS.....	11
7.1	Antenna Requirement – FCC: Section 15.203	11
7.2	Power Line Conducted Emissions – FCC: Section 15.207 IC: RSS-Gen 8.8.....	11
7.3	Peak Output Power - FCC Section 15.247(b)(1) IC: RSS-247 5.4(2)	14
7.4	Channel Usage Requirements.....	20
7.5	Band-Edge Compliance and Spurious Emissions-FCC 15.247(d) IC: RSS-247 5.5.....	37
8	CONCLUSION.....	65

1 GENERAL**1.1 Purpose**

The purpose of this report is to demonstrate compliance with Part 15 Subpart C of the FCC's Code of Federal Regulations and Industry Canada's Radio Standards Specification RSS-247.

1.2 Product Description

The MS2G and MS2GC consist of ultra-rugged tablet computers, featuring a 7-inch touchscreen display and running Microsoft Windows 8.1/10 Professional, Bluetooth 4.0 and WLAN 802.11a/b/g/n. The two models are identical except that the MS2GC model includes a pre-approved cellular module (FCC ID: VSF25271/ IC:7980A-25271). This test report documents the compliance of Bluetooth transceiver.

Technical Details

Mode of Operation: Bluetooth 2.1 + Enhanced Data Rate (EDR)
Frequency Range: 2402 MHz - 2480 MHz
Number of Channels: 79
Channel Separation: 1 MHz
Modulations: GFSK, $\pi/4$ -DQPSK, 8DPSK
TX Data Rates: GFSK: 1Mbps
 $\pi/4$ -DQPSK: 2Mbps
8DPSK: 3Mbps
Antenna Type/Gain: PIFA, 2.5 dB

1.3 Manufacturer Information

Juniper Systems, Inc.
1132 West 1700 North
Logan, UT 84321

Model Number: MS2G and MS2GC

Test Sample Serial Number(s): MS2P34 (Radiated & Power Line Conducted Emissions), MS2P58 (RF Conducted)

Test Sample Condition: The samples were in good conditions with no observable physical damages.

1.4 Test Methodology and Considerations

The EUT was evaluated for radiated, power line and RF conducted emissions. The configurations of the EUT for the testing is provided below.

For radiated emissions, preliminary evaluation was performed for the EUT standalone as well as for the EUT powered through a wall adapter. The investigation was performed in three orthogonal orientations. Additional measurements were performed on two MS2 models configurations consisting of the MS2G and the MS2GC. No significant emission variation was observed between the models and the final measurements were performed on MS2G model.

The RF conducted emissions measurements were performed for the EUT modified with a temporary RF connector for direct coupling to a spectrum analyzer.

The EUT was also evaluated for intermodulation product for the MS2GC model which includes the EM7355 cellular module (FCC ID: VSF25271/ IC:7980A-25271). The Bluetooth transceiver and Cell radios were set to transmit simultaneously and the intermodulation products were investigated and compared to the FCC Section 15.209 and the RSS-GEN general limits. All intermodulation products were found to be compliant.

Table 1.4-1: Bluetooth Radio Test configuration

Mode of Operations	Frequency (MHz)	Data Rate (kbps)
GFSK	2402	1000
	2441	1000
	2480	1000
$\pi/4$ DQPSK	2402	2000
	2441	2000
	2480	2000
8 DPSK	2402	3000
	2441	3000
	2480	3000

The EUT was also evaluated for unintentional emissions. The results are documented separately in a Declaration of Conformity/Verification test report.

2 TEST FACILITIES

2.1 Location

The radiated and conducted emissions test sites are located at the following address:

Advanced Compliance Solutions, Inc.
3998 FAU Blvd, Suite 310
Boca Raton, Florida 33431
Phone: (561) 961-5585
Fax: (561) 961-5587
www.acstestlab.com

FCC Test Firm Registration #: 475089
Industry Canada Lab Code: 4175C

2.2 Laboratory Accreditations/Recognitions/Certifications

ACS is accredited to ISO/IEC 17025 by ANSI-ASQ National Accreditation Board under their ANAB program and has been issued certificate number AT-1533 in recognition of this accreditation. Unless otherwise specified, all test methods described within this report are covered under the ISO/IEC 17025 scope of accreditation.

2.3 Radiated & Conducted Emissions Test Site Description

2.3.1 Semi-Anechoic Chamber Test Site

The EMC radiated test facility consists of an RF-shielded enclosure. The interior dimensions of the indoor semi-anechoic chamber are approximately 48 feet (14.6 m) long by 36 feet (10.8 m) wide by 24 feet (7.3 m) high and consist of rigid, 1/8 inch (0.32 cm) steel-clad, wood core modular panels with steel framing. In the shielded enclosure, the faces of the panels are galvanized and the chamber is self-supporting. 8-foot RF absorbing cones are installed on 4 walls and the ceiling. The steel-clad ground plane is covered with vinyl flooring.

The turntable is driven by pneumatic motor, which is capable of supporting a 2000 lb. load. The turntable is flush with the chamber floor which it is connected to, around its circumference, with a continuous metallic loaded spring. An EMCO Model 1050 Multi-device controller controls the turntable position.

A pneumatic motor is used to control antenna polarizations and height relative to the ground. The height information is displayed on the control unit EMCO Model 1050.

The control room is an RF shielded enclosure attached to the semi-anechoic chamber with two bulkhead panels for connecting RF, and control cables. The dimension of the room is 7.3 m x 4.9 m x 3 m high and the entrance doors of both control and conducted rooms are 3 feet (0.91 m) by 7 feet (2.13 m).

A diagram of the Semi-Anechoic Chamber Test Site is shown in Figure 2.3.1-1 below:

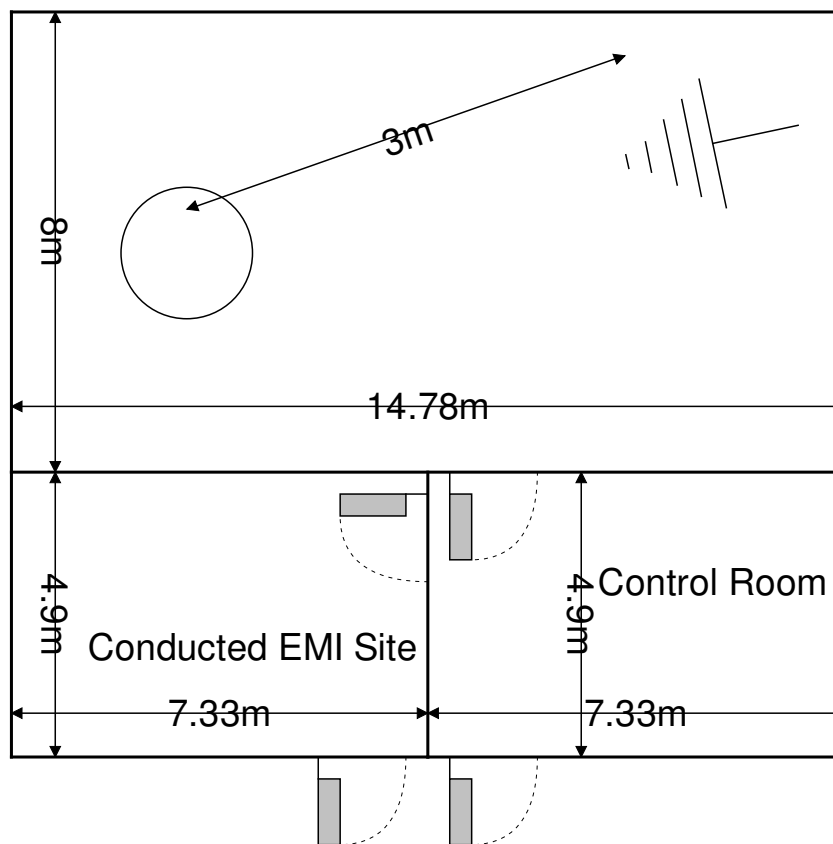

Figure 2.3.1-1: Semi-Anechoic Chamber Test Site

2.3.2 Conducted Emissions Test Site Description

The dimensions of the shielded conducted room are 7.3 x 4.9 x 3 m³. The power line conducted emission site includes two LISNs: a Solar Model 8028-50 50 Ω/50 μH and an EMCO Model 3825/2R, which are installed as shown in the figure below. For evaluations requiring 230 V, 50 Hz AC input, a Polarad LISN (S/N 879341/048) is used in conjunction with a California Instruments signal generator Model 2001RP-OP1.

A diagram of the room is shown below in figure 2.3.2-1:

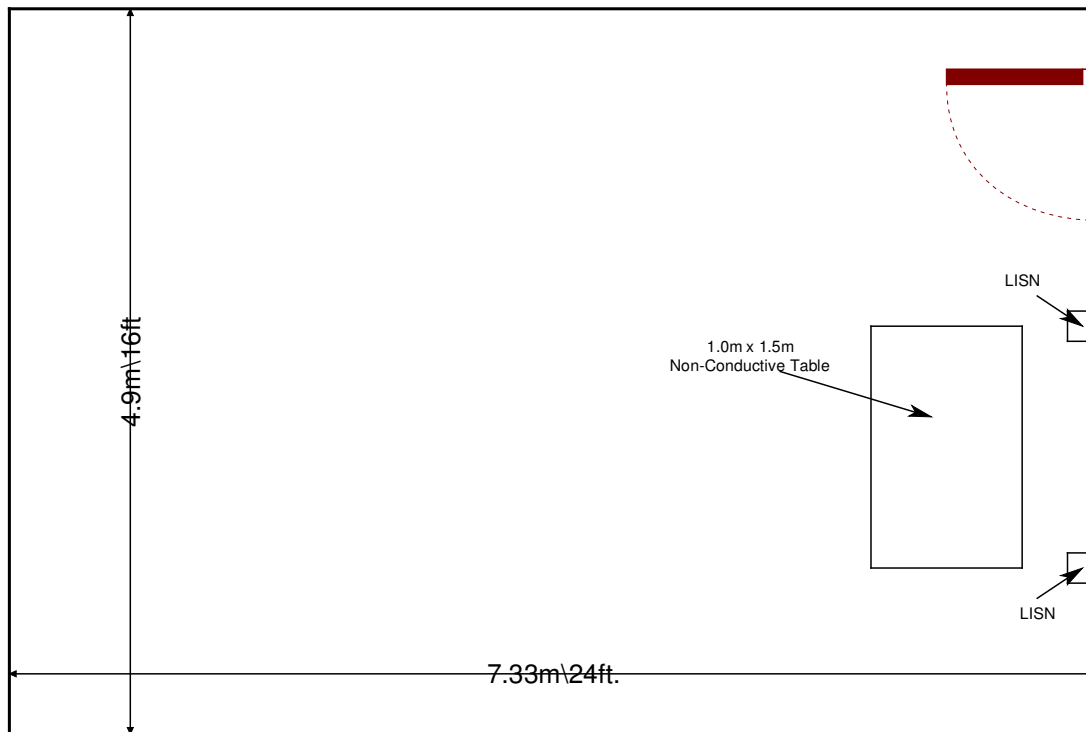

Figure 2.3.2-1: AC Mains Conducted EMI Site

3 APPLICABLE STANDARD REFERENCES

The following standards were used:

- ❖ ANSI C63.4-2014: Method of Measurements of Radio-Noise Emissions from Low-Voltage Electrical and Electronic Equipment in the 9 kHz to 40 GHz.
- ❖ ANSI C63.10-2013: American National Standard of Procedures for Compliance Testing of Unlicensed Wireless Devices
- ❖ US Code of Federal Regulations (CFR): Title 47, Part 2, Subpart J: Equipment Authorization Procedures, 2016.
- ❖ US Code of Federal Regulations (CFR): Title 47, Part 15, Subpart C: Radio Frequency Devices, Intentional Radiators, 2016
- ❖ Industry Canada Radio Standards Specification: RSS-247 — Digital Transmission Systems (DTSs), Frequency Hopping Systems (FHSs) and Licence-Exempt Local Area Network (LE-LAN) Devices, Issue 1, May 2015.
- ❖ Industry Canada Radio Standards Specification: RSS-GEN – General Requirements for Compliance of Radio Apparatus, Issue 4, November 2014.

4 LIST OF TEST EQUIPMENT

The calibration interval of test equipment is annually or the manufacturer's recommendations. Where the calibration interval deviates from the annual cycle based on the instrument manufacturer's recommendations, it shall be stated below.

Table 4-1: Test Equipment List

AssetID	Manufacturer	Model #	Equipment Type	Serial #	Last Calibration Date	Calibration Due Date
22	Agilent	8449B	Amplifiers	3008A00526	5/18/2015	5/18/2016
283	Rohde & Schwarz	FSP40	Spectrum Analyzers	1000033	7/1/2015	7/1/2016
479	Electro-Metrics	ALP-70	Antennas	158	12/2/2013	12/2/2015
479	Electro-Metrics	ALP-70	Antennas	158	12/3/2015	12/3/2017
523	Agilent	E7405	Spectrum Analyzers	MY45103293	12/26/2014	12/26/2016
653	Suhner	SF-102A	Cables	0944/2A	4/13/2015	4/13/2016
2002	EMCO	3108	Antennas	2147	11/19/2015	11/19/2017
2004	EMCO	3146	Antennas	1385	11/19/2015	11/19/2017
2006	EMCO	3115	Antennas	2573	4/14/2015	4/14/2017
2008	COM-Power	AH-826	Antennas	81009	NCR	NCR
2011	Hewlett-Packard	HP 8447D	Amplifiers	2443A03952	11/18/2015	11/18/2016
2022	EMCO	LISN3825/2R	LISN	1095	9/14/2015	9/14/2017
2045	ACS Boca	Conducted Cable Set	Cable Set	2045	11/11/2015	11/11/2016
2070	Mini Circuits	VHF-8400+	Filter	2070	11/17/2015	11/17/2016
2072	Mini Circuits	VHF-3100+	Filter	30737	11/17/2015	11/17/2016
2075	Hewlett Packard	8495B	Attenuators	2626A11012	11/18/2015	11/18/2016
2082	Teledyne Storm Products	90-010-048	Cables	2082	4/22/2015	4/22/2016
2086	Merrimac	FAN-6-10K	Attenuators	23148-83-1	11/16/2015	11/16/2016
2089	Agilent Technologies, Inc.	83017A	Amplifiers	3123A00214	12/9/2015	12/9/2016
2095	ETS Lindgren	TILE4! - Version 4.2.A	Software	85242	NCR	NCR
2111	Aeroflex Inmet	40AH2W-20	Attenuator	2111	7/22/2015	7/22/2016
2121	ACS Boca	Radiated Cable Set	Cable Set	2121	8/22/2015	8/22/2016
3004	Teseq	CFL 9206A	Attenuators	34720	10/7/2015	10/7/2016
RE619	Rhode & Schwarz	ESU26	Spectrum Analyzers	1302.6005K26 Ser. 100190	11/5/2014	11/5/2016

Notes:

- **NCR=No Calibration Required**
- **The calibration information cycle for asset 479 is provided to cover the entire test period. The asset was only used during the active period of the calibration cycle.**

5 SUPPORT EQUIPMENT

Table 5-1: EUT and Support Equipment

Item #	Type Device	Manufacturer	Model/Part #	Serial #
1	EUT	Juniper Systems, Inc.	MS2	MS2P34
2	12 VDC Power Supply	PhiHong	PSAA20R-120	P51904229A1
3	Earbuds	Maxell	N/A	N/A
4	Mouse	Insignia	NS-PNC5001	15G03A003432

Table 5-2: Cable Description (Radiated Emissions)

Cable #	Cable Type	Length	Shield	Termination
A	Power	1.5 m	No	Power Supply To EUT
B	Audio	0.92 m	No	Earbuds to EUT
C	USB	1.55 m	No	Mouse to EUT
D	Extension Power Cord	2.7 m	No	Power Supply to AC Mains

6 EQUIPMENT UNDER TEST SETUP BLOCK DIAGRAM

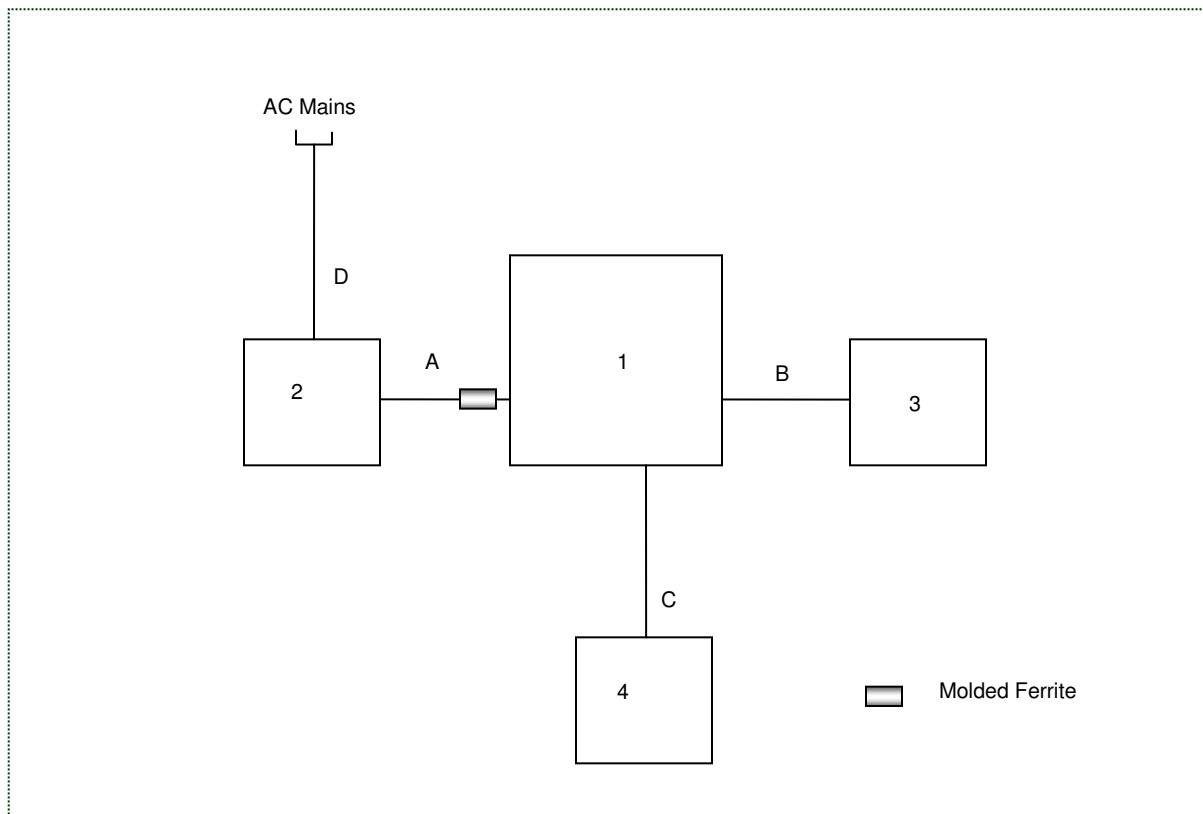

Figure 6-1: EUT Test Setup

7 SUMMARY OF TESTS

Along with the tabular data shown below, plots were taken of all signals deemed important enough to document.

7.1 Antenna Requirement – FCC: Section 15.203

The MS2 uses a 2.5 dBi Internal PIFA that is directly soldered to the PCB. The antenna is neither removable nor accessible to the end-user. Thus, the equipment meets the requirements of FCC Section 15.203.

7.2 Power Line Conducted Emissions – FCC: Section 15.207 IC: RSS-Gen 8.8

7.2.1 Measurement Procedure

ANSI C63.4 sections 6 and 7 were the guiding documents for this evaluation. Conducted emissions were performed from 150 kHz to 30 MHz with the spectrum analyzer’s resolution bandwidth set to 9 kHz and the video bandwidth set to 30 kHz. The calculation for the conducted emissions is as follows:

Corrected Reading = Analyzer Reading + LISN Loss + Cable Loss
Margin = Applicable Limit - Corrected Reading

7.2.2 Measurement Results

Results of the test corresponding to the EUT configuration leading to the worse case emissions are shown below:

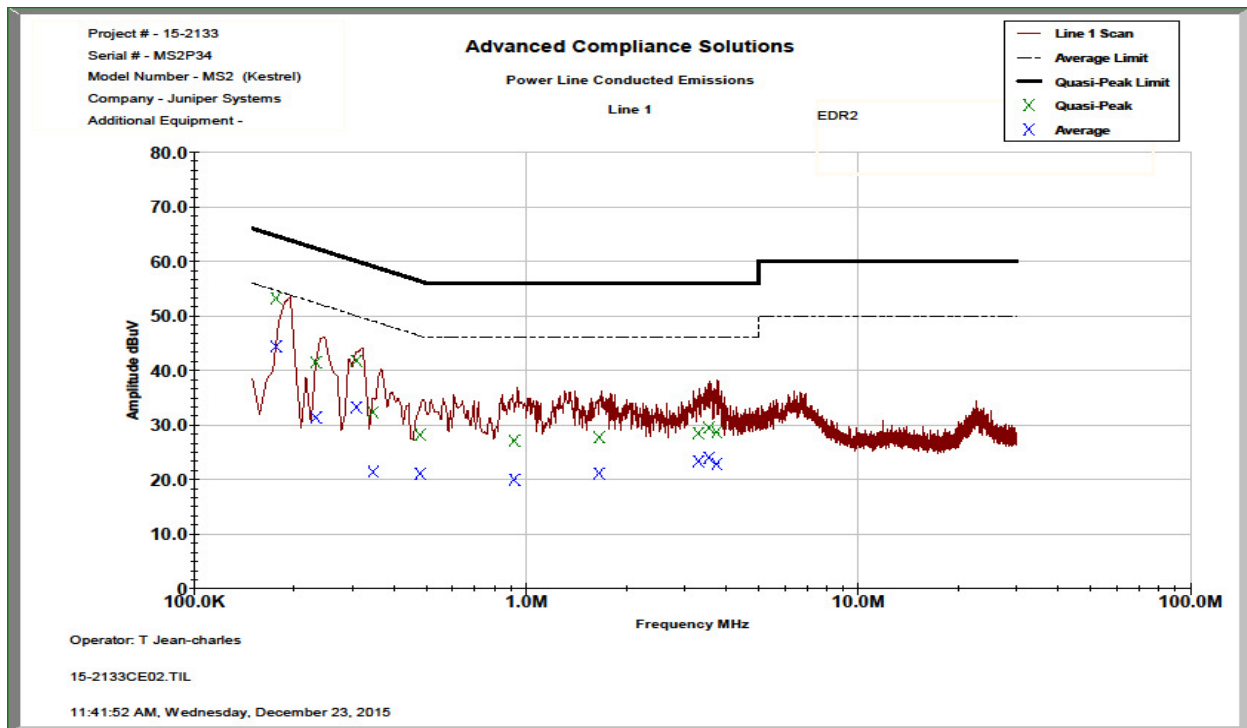

Figure 7.2.2-1: Conducted Emissions Results – Line 1

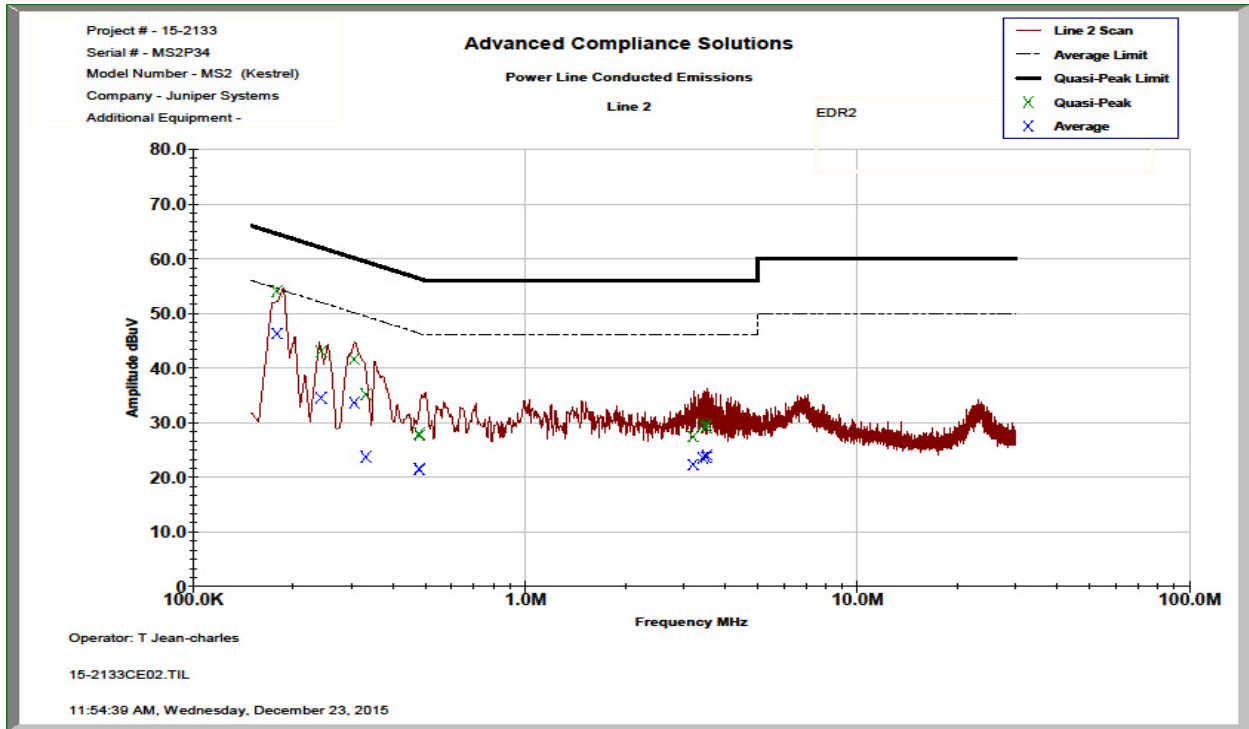

Figure 7.2.2-2: Conducted Emissions Results – Line 2

Table 7.2.2-1: Conducted EMI Results

Line 1 Line 2 Line 3
 Line 4
 To Ground Floating
 Telecom Port _____
 dBµV dBµA

 Plot Number: 15-2133CE02
 Power Supply Description: 12 VDC

Frequency (MHz)	Uncorrected Reading		Total Correction Factor (dB)	Corrected Level		Limit		Margin (dB)	
	Quasi-Peak	Average		Quasi-Peak	Average	Quasi-Peak	Average	Quasi-Peak	Average
Line 1									
0.176375	43.057	34.215	10.20	53.26	44.42	64.65	54.65	11.4	10.2
0.232713	31.276	21.162	10.21	41.48	31.37	62.35	52.35	20.9	21.0
0.308637	31.629	23.072	10.20	41.83	33.28	60.01	50.01	18.2	16.7
0.346413	22.144	11.205	10.20	32.35	21.41	59.05	49.05	26.7	27.6
0.479999	18.055	10.87	10.21	28.26	21.08	56.34	46.34	28.1	25.3
0.921025	16.947	9.82	10.19	27.13	20.01	56.00	46.00	28.9	26.0
1.65981	17.513	10.916	10.20	27.72	21.12	56.00	46.00	28.3	24.9
3.30156	18.159	13.046	10.35	28.51	23.40	56.00	46.00	27.5	22.6
3.55529	19.129	13.675	10.35	29.48	24.03	56.00	46.00	26.5	22.0
3.74931	18.305	12.499	10.35	28.66	22.85	56.00	46.00	27.3	23.1
Line 2									
0.179113	43.845	36.057	10.22	54.07	46.28	64.53	54.53	10.5	8.2
0.24305	32.832	24.329	10.22	43.05	34.55	61.99	51.99	18.9	17.4
0.305962	31.429	23.391	10.21	41.64	33.60	60.08	50.08	18.4	16.5
0.331488	24.965	13.531	10.21	35.18	23.74	59.41	49.41	24.2	25.7
0.48	17.795	11.329	10.21	28.01	21.54	56.34	46.34	28.3	24.8
0.480738	17.452	11.151	10.21	27.66	21.36	56.33	46.33	28.7	25.0
3.20455	17.039	11.919	10.39	27.43	22.31	56.00	46.00	28.6	23.7
3.42842	19.418	13.158	10.39	29.81	23.55	56.00	46.00	26.2	22.5
3.50305	18.781	13.303	10.39	29.17	23.69	56.00	46.00	26.8	22.3
3.52544	19.224	13.695	10.39	29.61	24.09	56.00	46.00	26.4	21.9

7.3 Peak Output Power - FCC Section 15.247(b)(1) IC: RSS-247 5.4(2)

7.3.1 Measurement Procedure (Conducted Method)

The RF output port of the EUT was directly connected to the input of the spectrum analyzer through suitable attenuation.

7.3.2 Measurement Results

Results are shown below:

Table 7.3.2-1: RF Output Power (GFSK)

Frequency (MHz)	Power (dBm)
2402	8.26
2441	7.71
2480	7.56

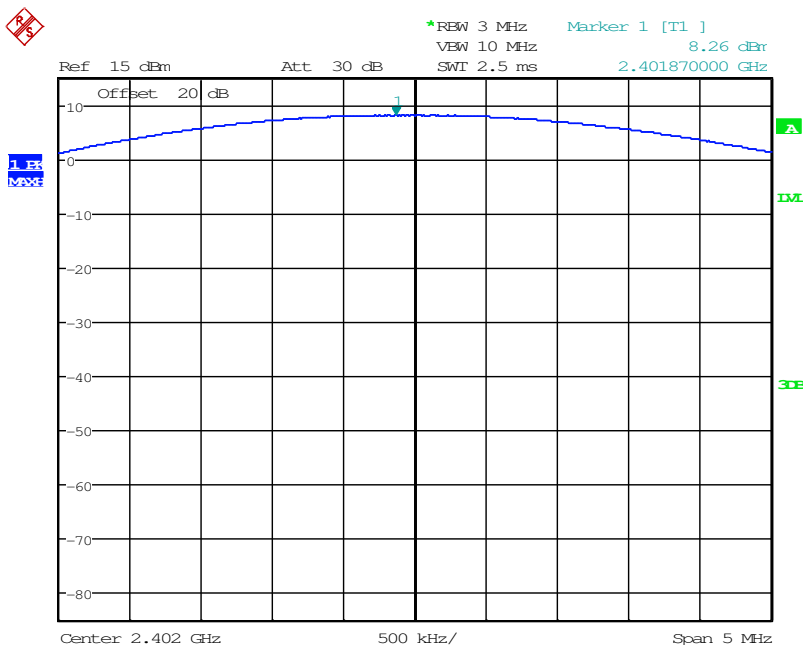

Date: 28.DEC.2015 23:09:52

Figure 7.3.2-1: RF Output Power (GFSK) - Low Channel

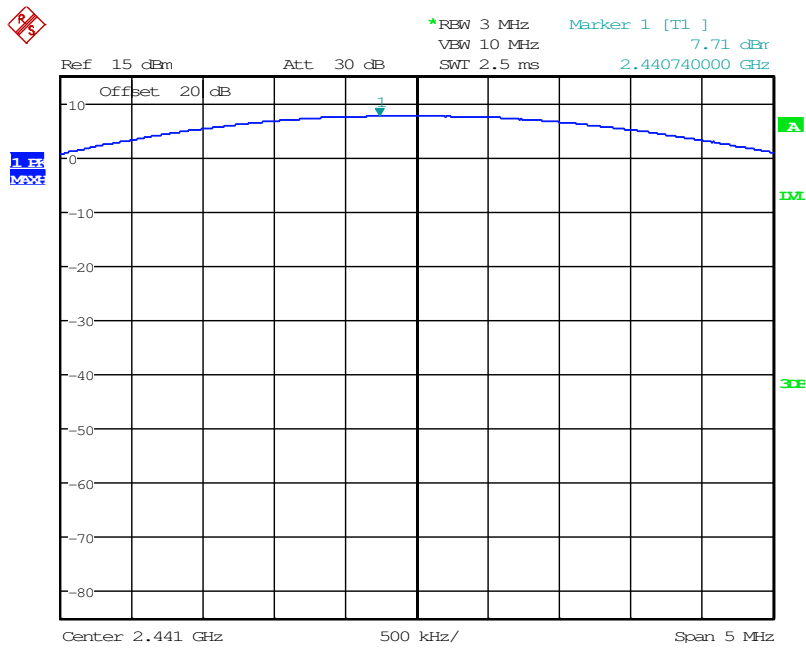

Date: 28.DEC.2015 23:19:44

Figure 7.3.2-2: RF Output Power (GFSK) - Middle Channel

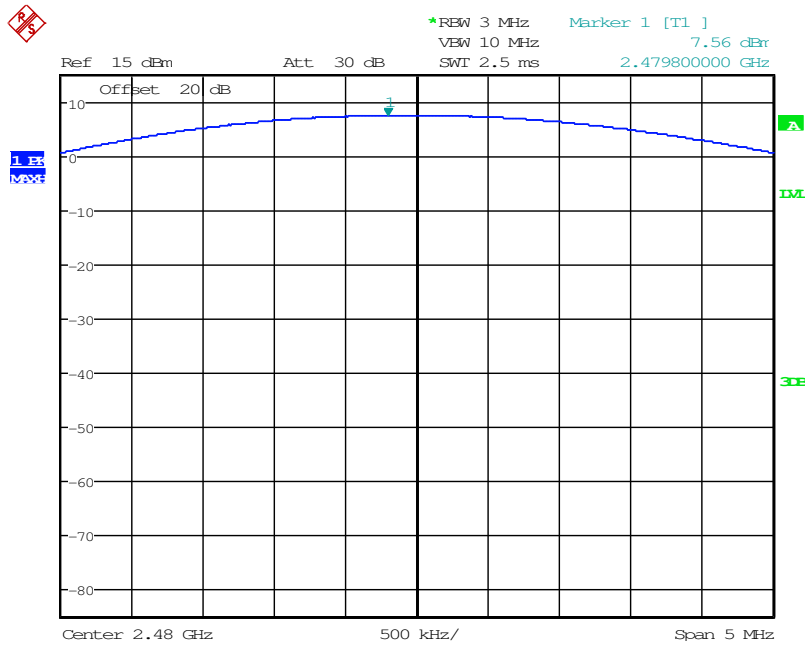

Date: 28.DEC.2015 23:21:23

Figure 7.3.2-3: RF Output Power (GFSK) - High Channel

Table 7.3.2-2: RF Output Power ($\pi/4$ DQPSK)

Frequency (MHz)	Power (dBm)
2402	7.65
2441	6.92
2480	6.43

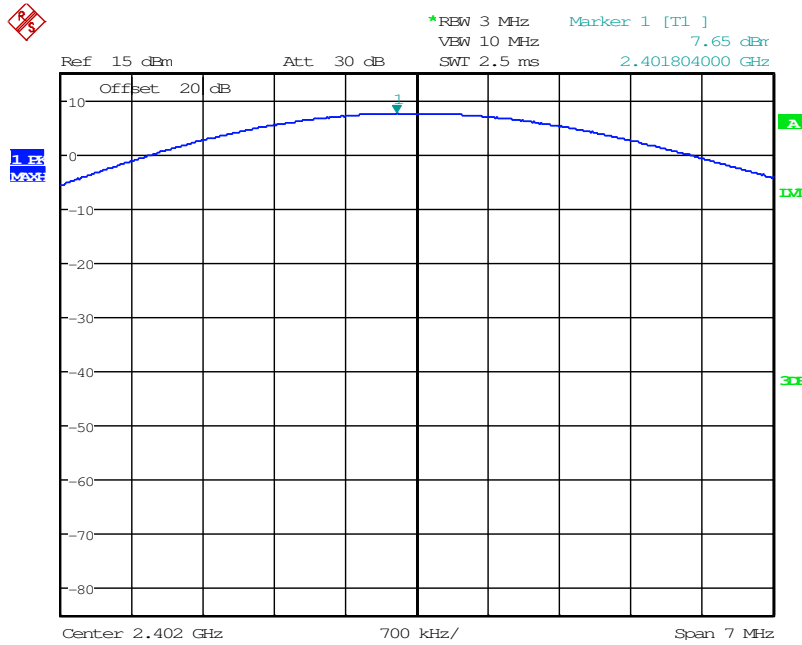

Date: 28.DEC.2015 23:13:17

Figure 7.3.2-4: RF Output Power ($\pi/4$ DQPSK) - Low Channel

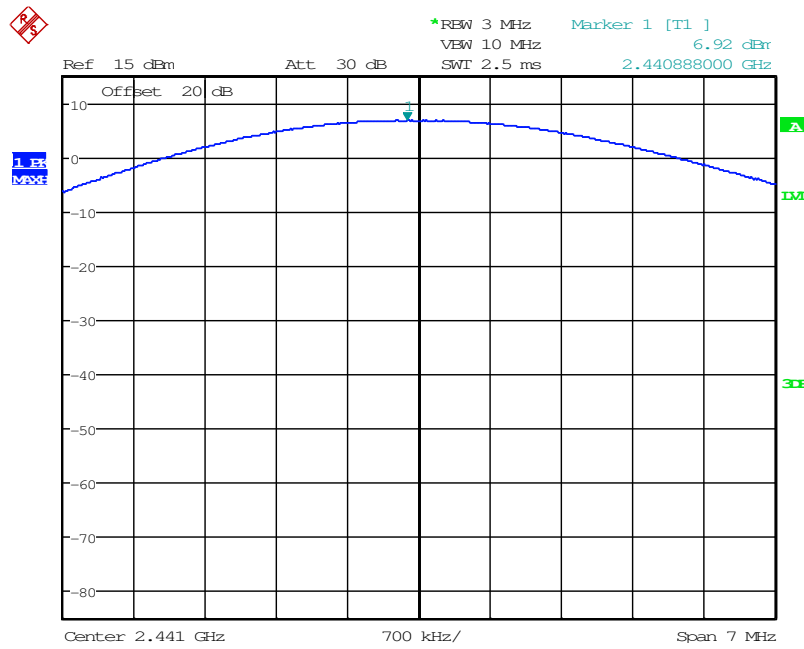

Date: 28.DEC.2015 23:15:38

Figure 7.3.2-5: RF Output Power ($\pi/4$ DQPSK) - Middle Channel

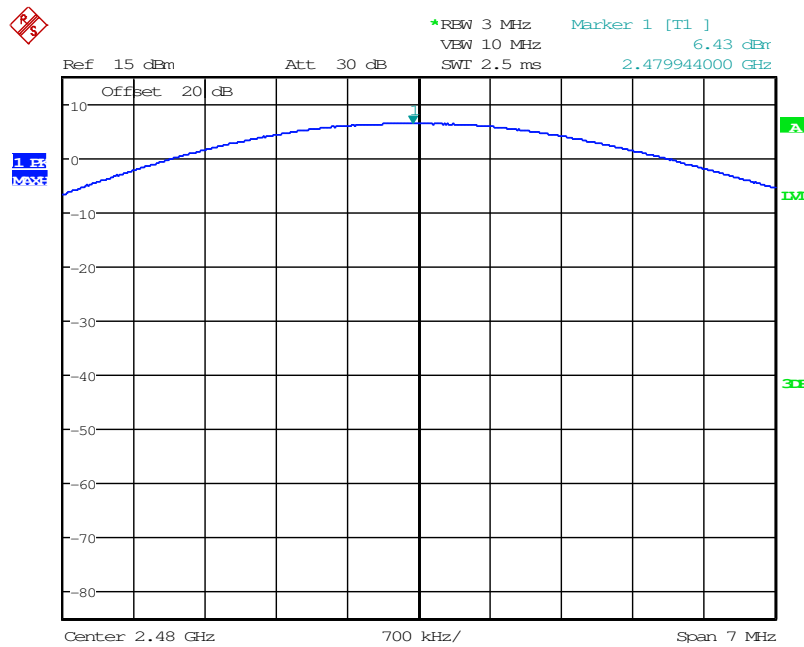

Date: 28.DEC.2015 23:24:16

Figure 7.3.2-6: RF Output Power ($\pi/4$ DQPSK) - High Channel

Table 7.3.2-3 RF Output Power (8DPSK)

Frequency (MHz)	Power (dBm)
2402	8.14
2441	7.44
2480	6.98

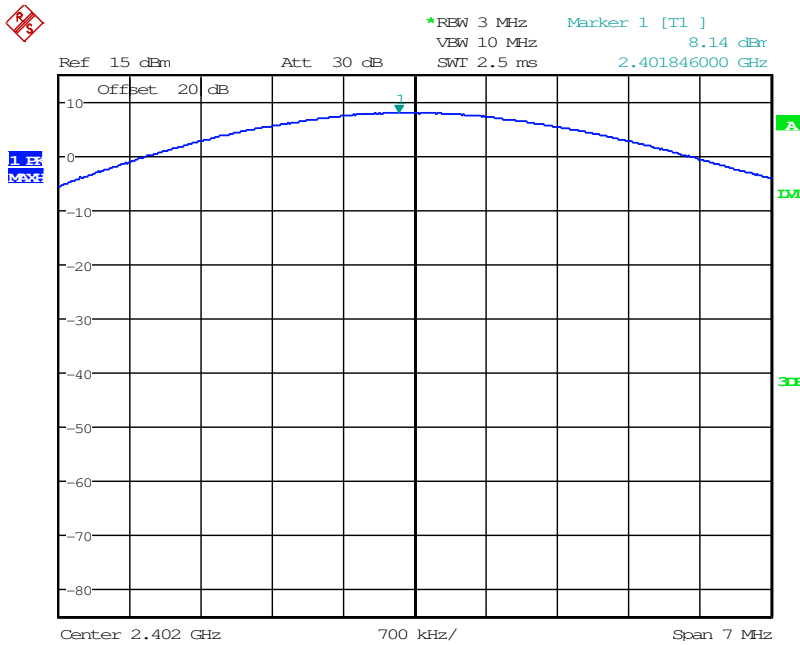

Date: 28.DEC.2015 23:11:45

Figure 7.3.2-7: RF Output Power (8DPSK) - Low Channel

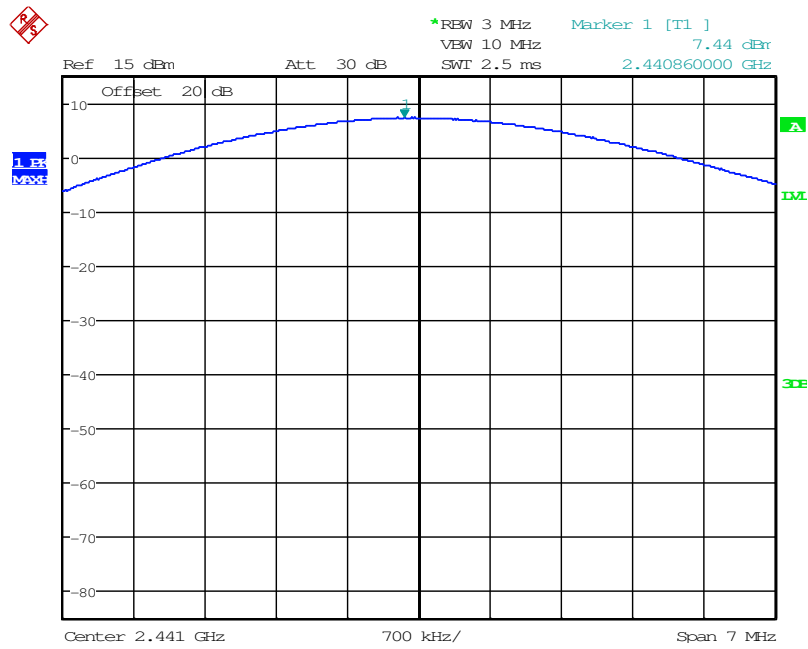

Date: 28.DEC.2015 23:17:42

Figure 7.3.2-8: RF Output Power (8DPSK) - Middle Channel

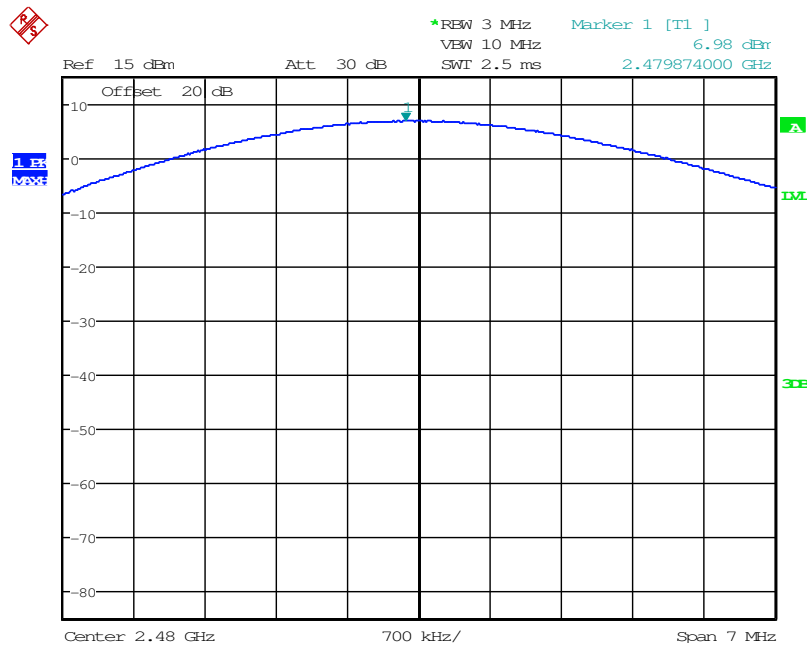

Date: 28.DEC.2015 23:22:20

Figure 7.3.2-9: RF Output Power (8DPSK) - High Channel

7.4 Channel Usage Requirements

7.4.1 Carrier Frequency Separation – FCC: Section 15.247(a)(1) IC: RSS-247 5.1(2)

7.4.1.1 Measurement Procedure

The RF output port of the EUT was directly connected to the input of the spectrum analyzer. The span of the spectrum analyzer was set wide enough to capture two adjacent peaks and the RBW and VBW were set to approximately 30% of the channel spacing.

7.4.1.2 Measurement Results

Results are shown below:

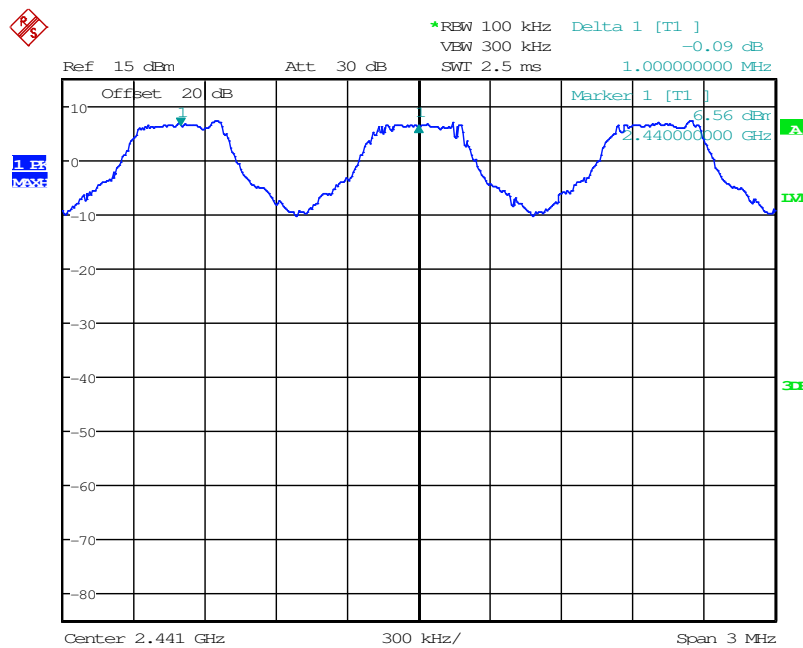

Date: 19.DEC.2015 17:08:10

Figure 7.4.1.2-1: Carrier Frequency Separation

7.4.2 Number of Hopping Channels – FCC: Section 15.247(a)(1)(iii) IC: RSS-247 5.1(4)

7.4.2.1 Measurement Procedure

The RF output port of the EUT was directly connected to the input of the spectrum analyzer. The span of the spectrum analyzer was set wide enough to capture the number of hopping channels. The peak detector max hold function was enabled for the measurements.

7.4.2.2 Measurement Results

Results are shown below:

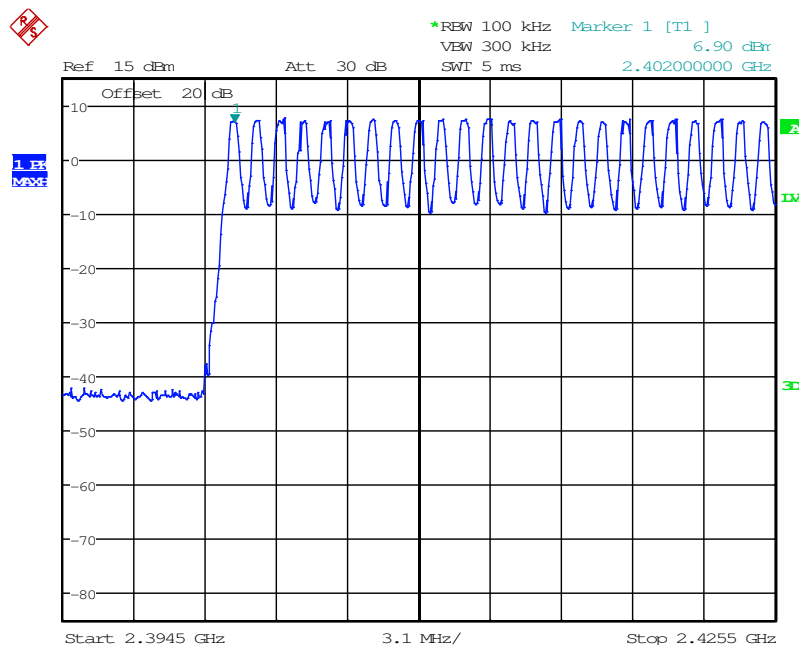

Date: 19.DEC.2015 18:10:06

Figure 7.4.2.2-1: Number of Hopping Channels (1 – 24)

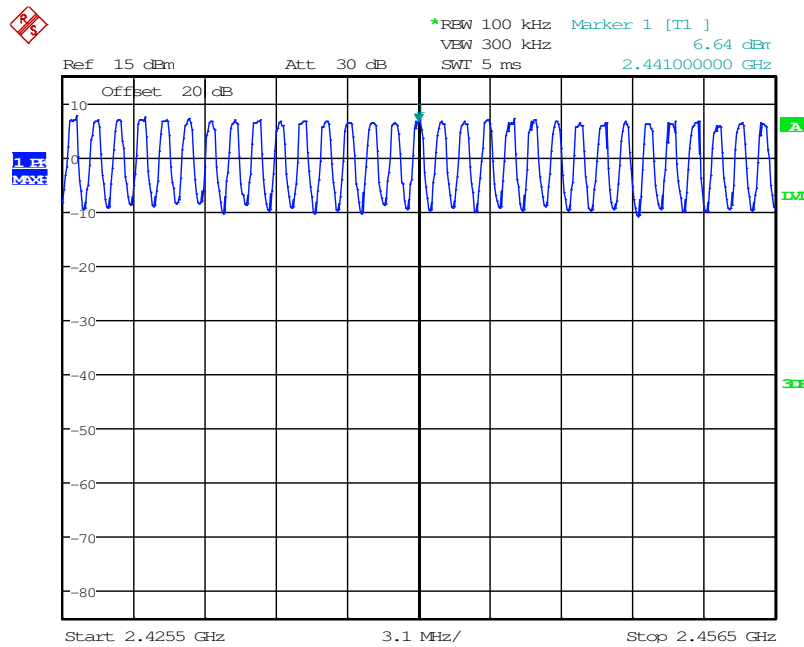

Date: 19.DEC.2015 18:11:55

Figure 7.4.2.2-2: Number of Hopping Channels (25 – 55)

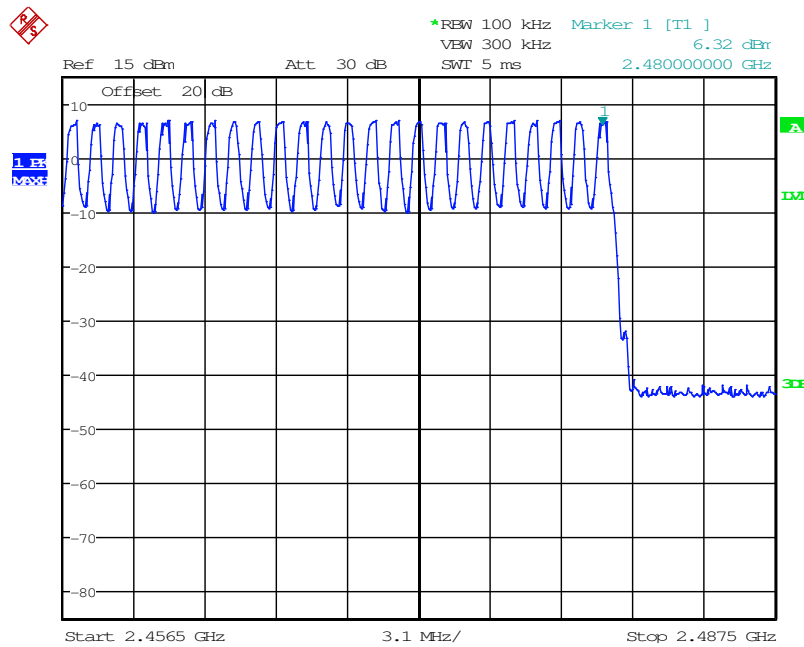

Date: 19.DEC.2015 18:15:02

Figure 7.4.2.2-3: Number of Hopping Channels (56 – 79)

7.4.3 Channel Dwell Time – FCC: Section 15.247(a)(1)(iii) IC: RSS-247 5.1(4)

7.4.3.1 Measurement Procedure

The RF output port of the EUT was directly connected to the input of the spectrum analyzer. The span of the spectrum analyzer was set 0 Hz centered on a hopping channel. The RBW was set to less than 30% of the channel spacing and the sweep time adjusted to capture the entire dwell time per channel with peak detector max hold function.

7.4.3.2 Measurement Results

Results are shown below:

Table 7.4.3.2-1 Dwell Time on a 31.6 Second Cycle

Packet Format	Number of Hops Per Sec. (NHPS)	Number of Hops per Channel Per Sec. (NHPCPS)	Number of hops on a 31.6 s Cycle (NHPC)	Measured Dwell Times (ms)	Dwell Times on a 31.6 s Cycle	Limit (ms)	Status
DH1	800	10.13	320	0.424	135.68	400	PASS
DH3	400	5.06	160	1.688	270.08	400	PASS
DH5	266.67	3.38	106.67	2.94	313.61	400	PASS

*Notes:

NHPS = (1600 /sec)/ (NT+NR) (where NT and NR are the number of transmit and receive packets, respectively)

NHPCPS = NHPS/79

NHPC = NHPCPS * 31.6s

Dwell Time per Cycle = NHPC* Measured Dwell Time

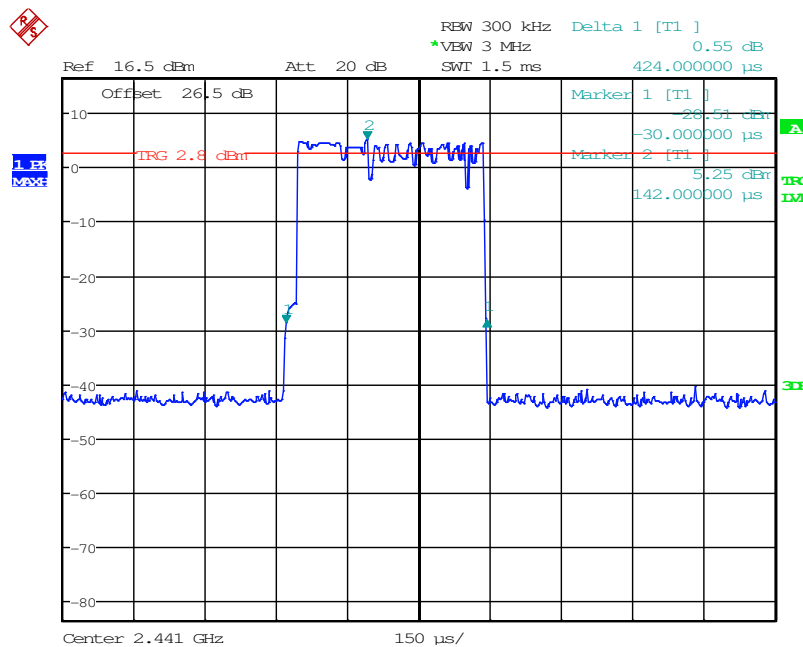

Date: 11.FEB.2016 20:17:39

Figure 7.4.3.2-1: Channel Dwell Time – DH1

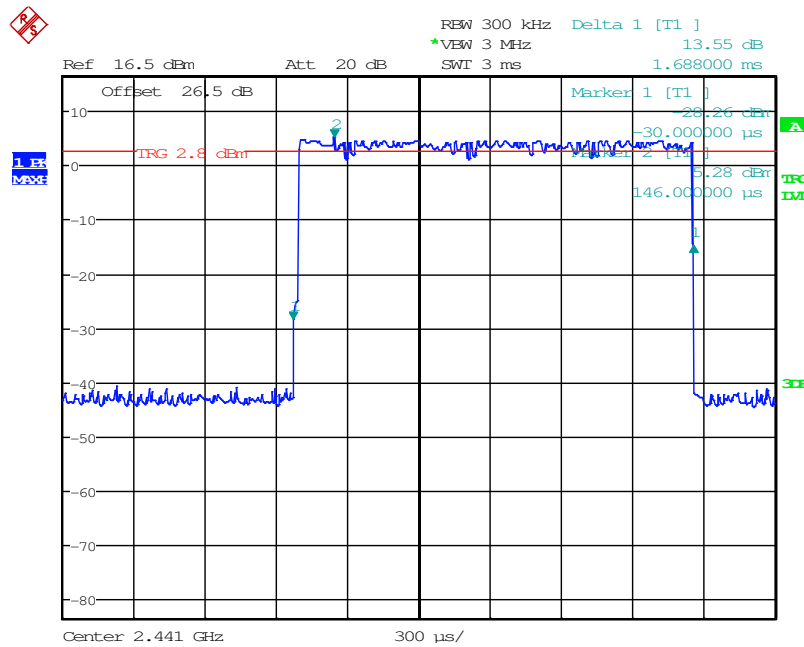

Date: 11.FEB.2016 20:12:57

Figure 7.4.3.2-2: Channel Dwell Time – DH3

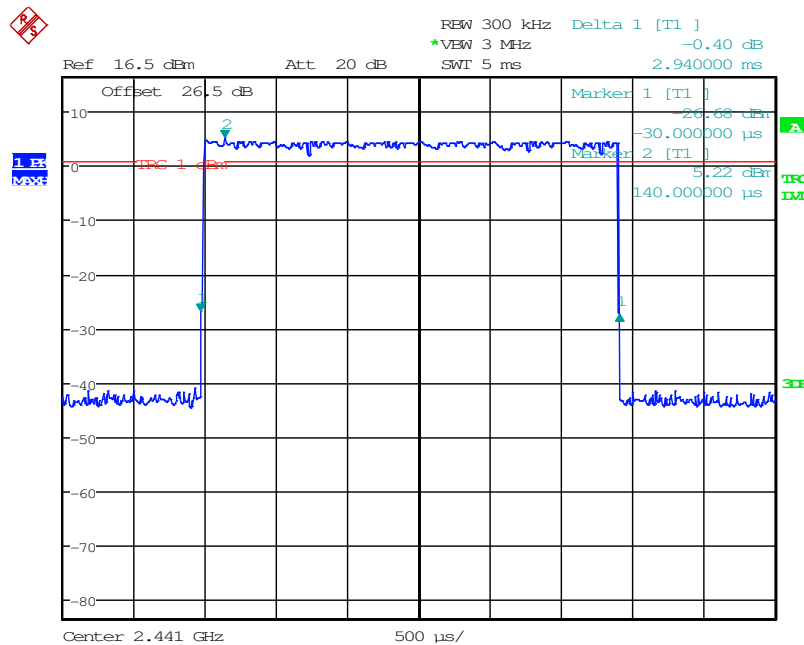

Date: 11.FEB.2016 20:06:31

Figure 7.4.3.2-3: Channel Dwell Time – DH5

7.4.4 20dB / 99% Bandwidth - FCC: Section 15.247(a)(1)(i) IC: RSS-247 5.1(1)

7.4.4.1 Measurement Procedure

The RF output port of the EUT was directly connected to the input of the spectrum analyzer. The spectrum analyzer span was set to 2 to 5 times the estimated bandwidth of the emission. The RBW was set to 1% to 5% of the estimated emission bandwidth. The trace was set to max hold with a peak detector active. For the GFSK modulation, the Delta function of the analyzer was utilized to determine the 20 dB bandwidth of the emissions. For the 8 DPSK and Pi/4DQPSK modulations, the N dB function of the spectrum analyzer was used to measure the 20 dB bandwidth.

The 99% occupied bandwidth was measured with the spectrum analyzer span set to fully display the emission. The RBW was set to 1% to 5% of the approximated bandwidth. The occupied 99% bandwidth was measured by using the 99% bandwidth equipment function of the spectrum analyzer.

7.4.4.2 Measurement Results

Results are shown below:

Table 7.4.4.2-1: 20dB / 99% Bandwidth

Frequency [MHz]	20dB Bandwidth [kHz]	99% Bandwidth [kHz]
2402	954	876
2441	954	876
2480	954	882

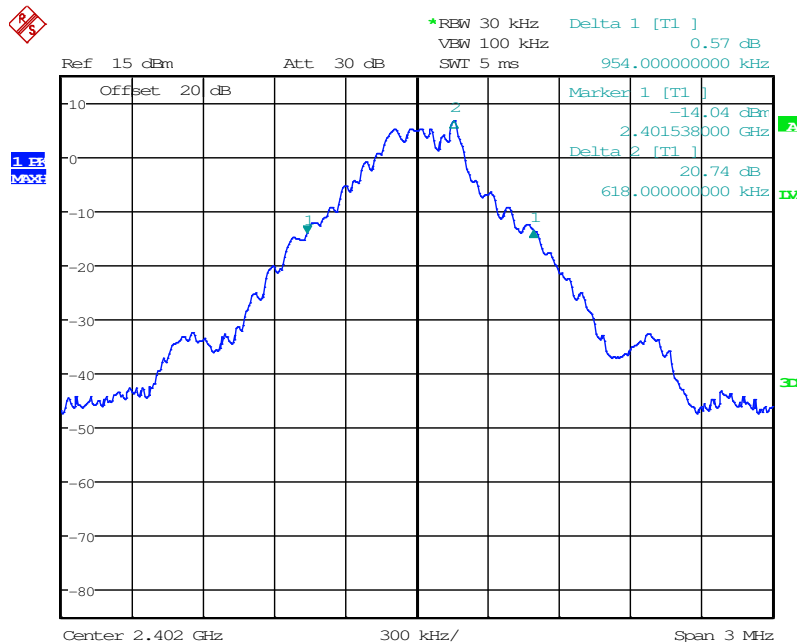

Date: 28.DEC.2015 23:08:08

Figure 7.4.4.2-1: 20dB BW Low Channel (GFSK)

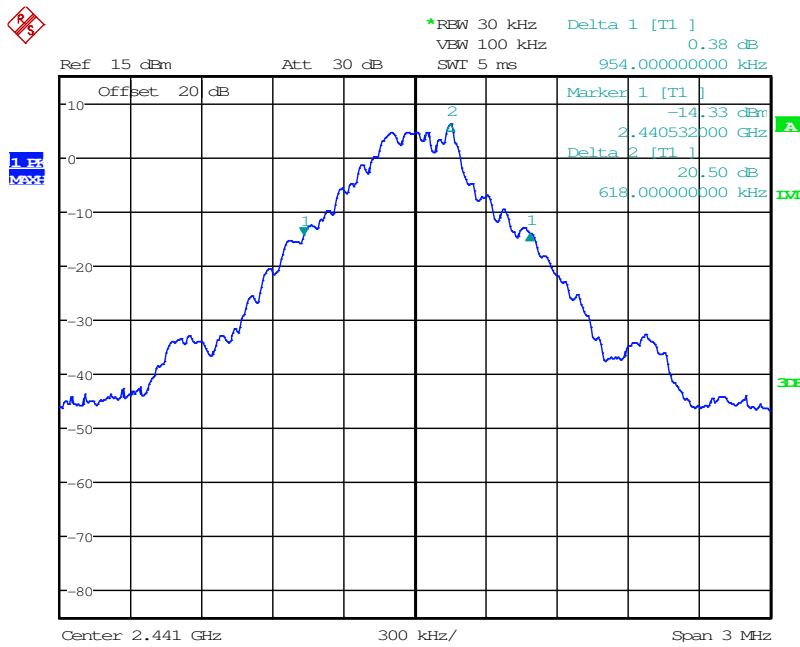

Date: 28.DEC.2015 22:57:30

Figure 7.4.4.2-2: 20dB BW Middle Channel (GFSK)

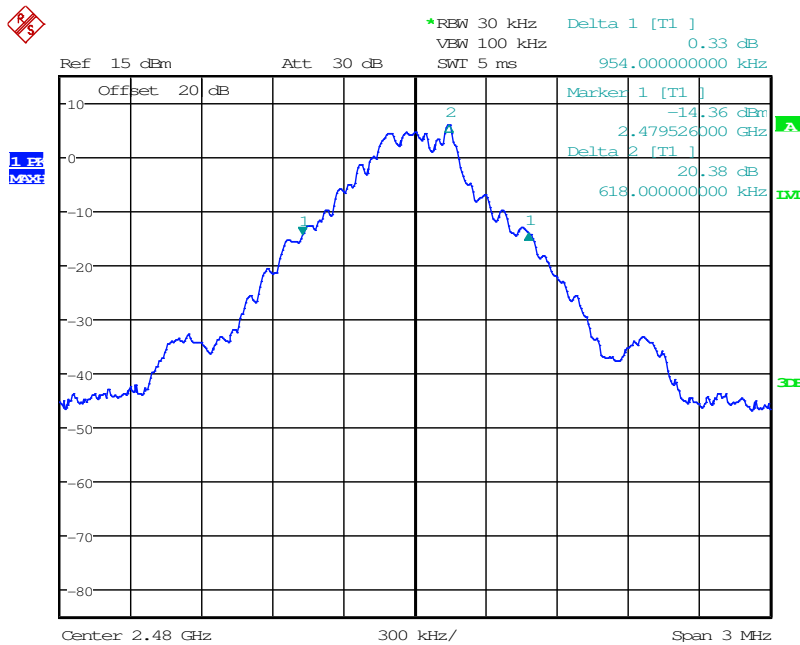

Date: 28.DEC.2015 23:05:50

Figure 7.4.4.2-3: 20dB BW High Channel (GFSK)

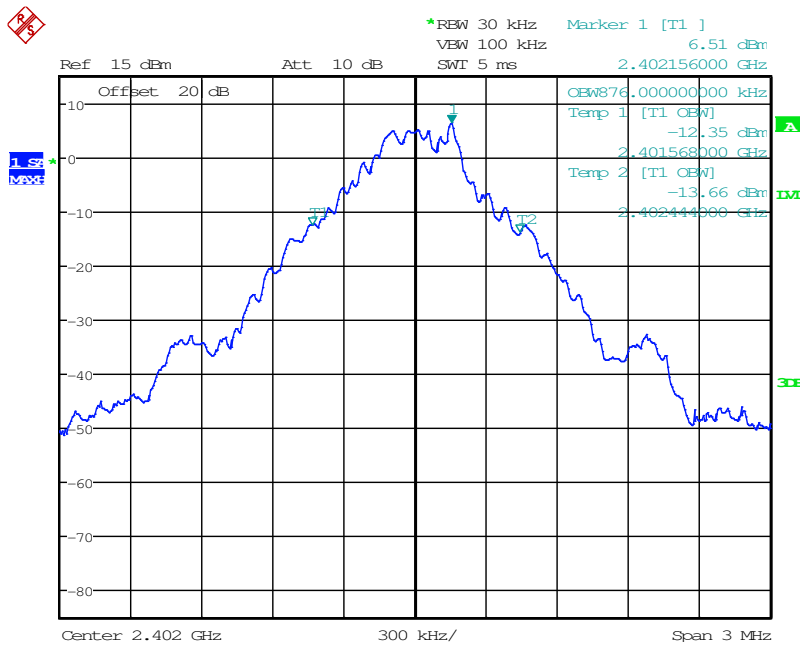

Date: 28.DEC.2015 22:01:14

Figure 7.4.4.2-4: 99% OBW Low Channel (GFSK)

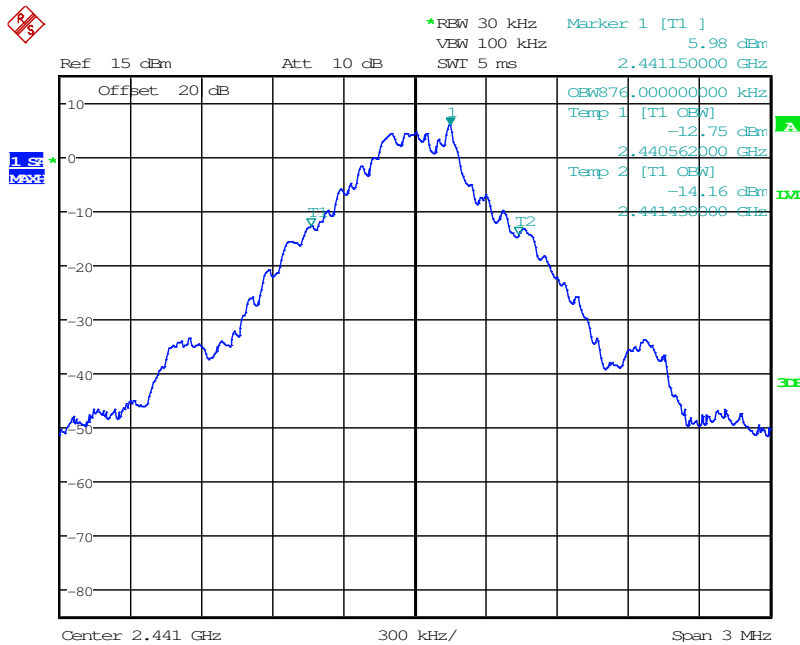

Date: 28.DEC.2015 22:03:04

Figure 7.4.4.2-5: 99% OBW Middle Channel (GFSK)

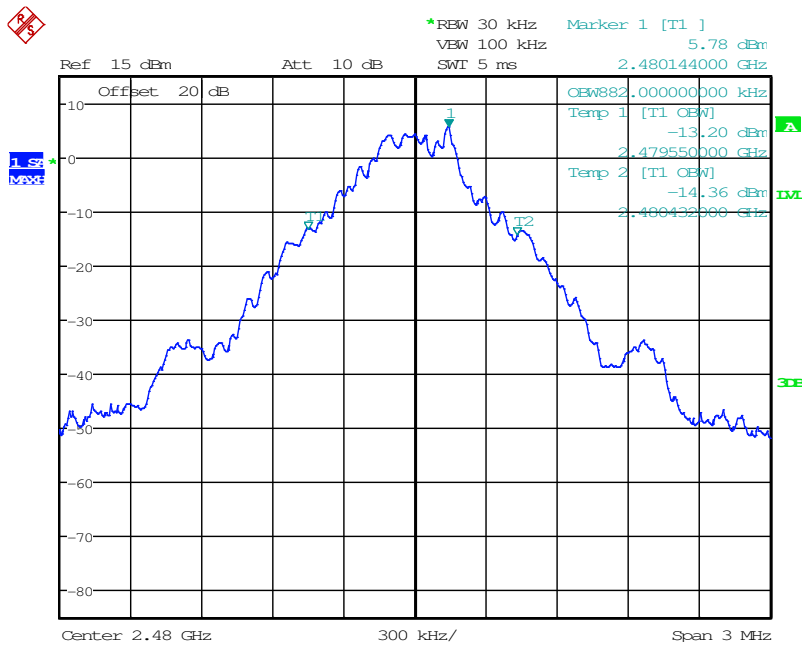

Date: 28.DEC.2015 22:05:50

Figure 7.4.4.2-6: 99% OBW High Channel (GFSK)

Table: 7.4.4.2-2: 20dB / 99% Bandwidth ($\pi/4$ DQPSK)

Frequency [MHz]	20dB Bandwidth [kHz]	99% Bandwidth [kHz]
2402	1360	1192
2441	1352	1192
2480	1352	1184

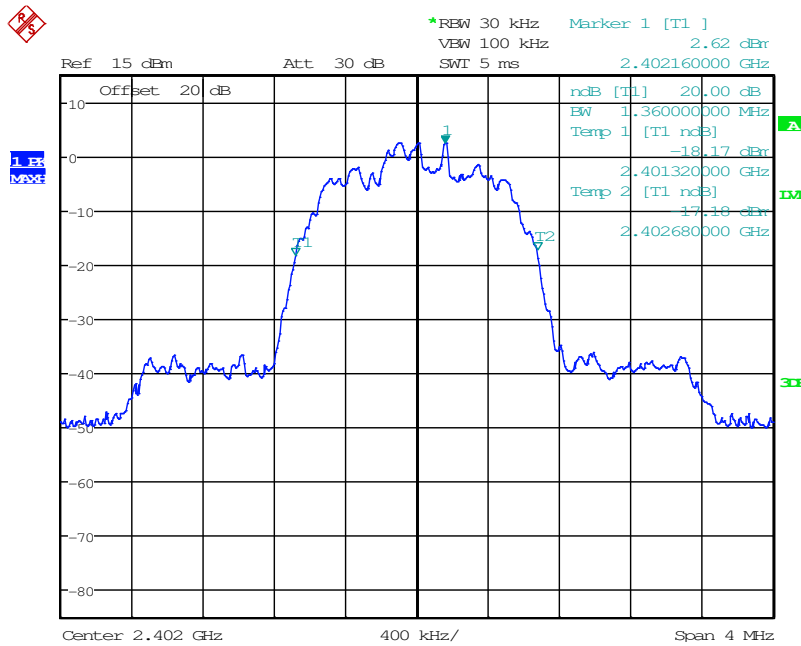

Date: 28.DEC.2015 22:43:03

Figure 7.4.4.2-7: 20dB BW Low Channel ($\pi/4$ DQPSK)

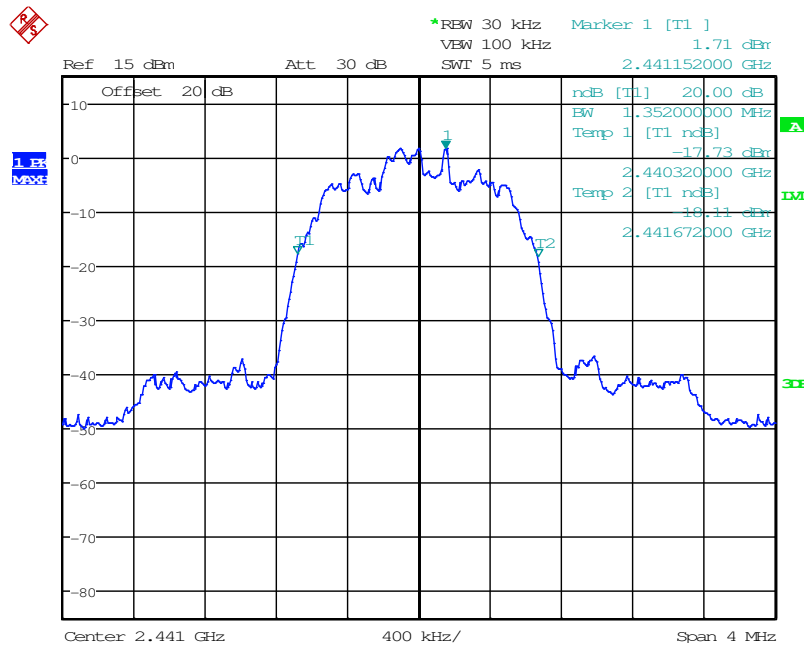

Date: 28.DEC.2015 22:40:28

Figure 7.4.4.2-8: 20dB BW Middle Channel ($\pi/4$ DQPSK)

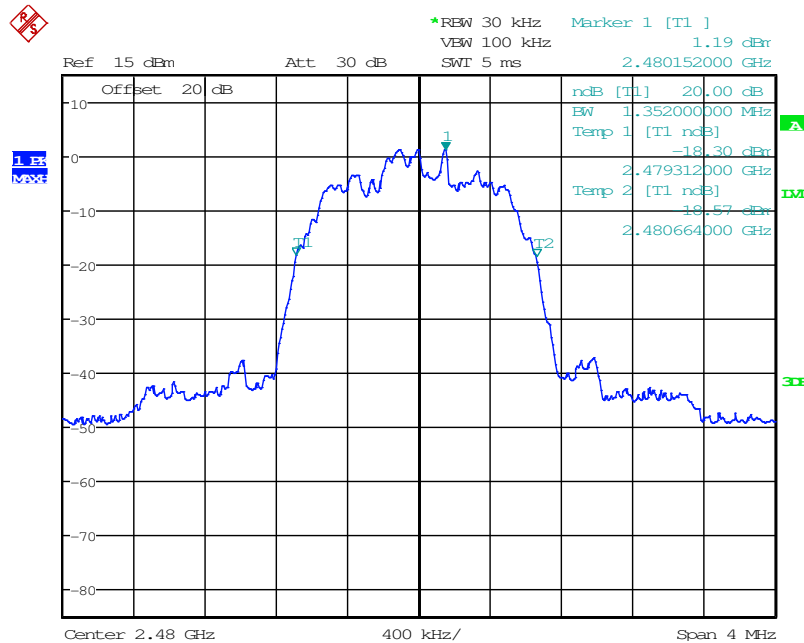

Date: 28.DEC.2015 22:31:50

Figure 7.4.4.2-9: 20dB BW High Channel ($\pi/4$ DQPSK)

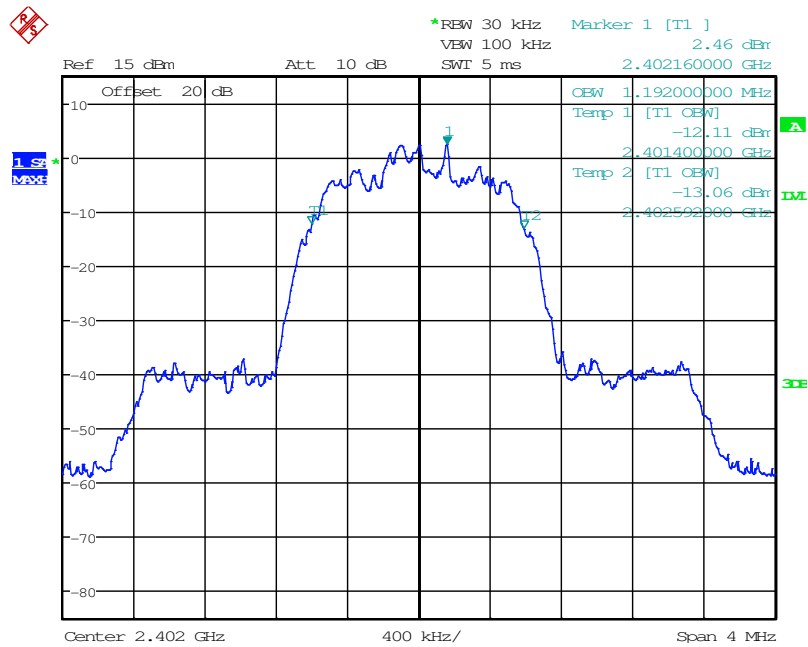

Date: 28.DEC.2015 22:23:25

Figure 7.4.4.2-10: 99% OBW Low Channel ($\pi/4$ DQPSK)

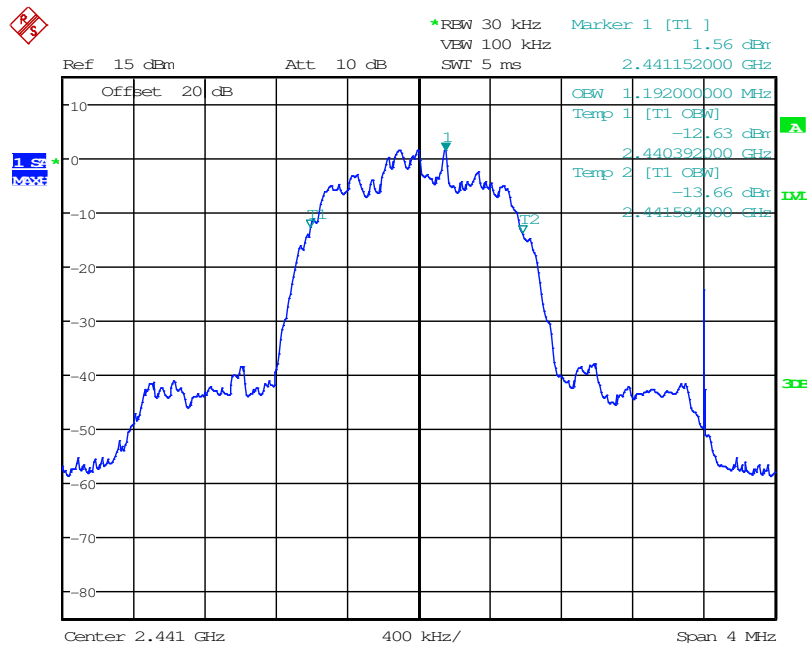

Date: 28.DEC.2015 22:26:21

Figure 7.4.4.2-11: 99% OBW Middle Channel ($\pi/4$ DQPSK)

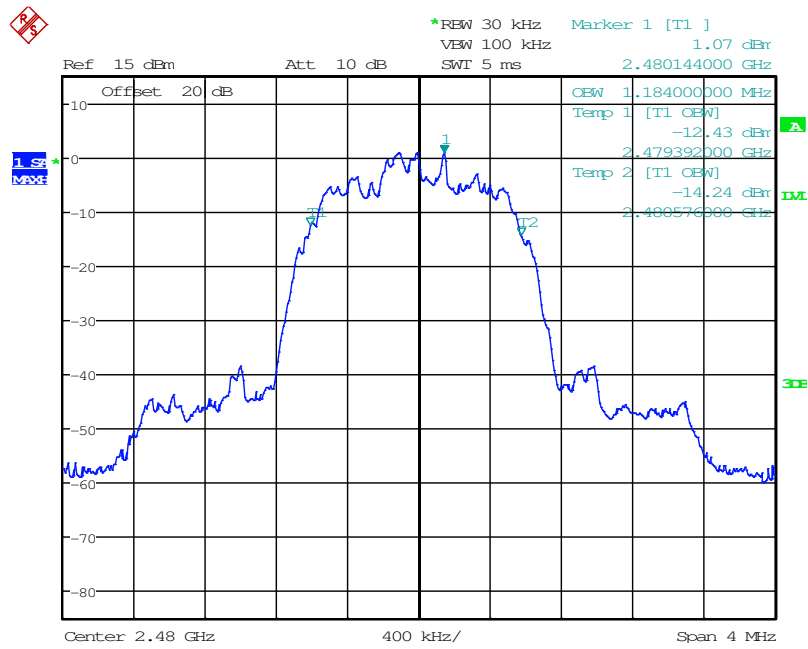

Date: 28.DEC.2015 22:28:43

Figure 7.4.4.2-12: 99% OBW High Channel ($\pi/4$ DQPSK)

Table 7.4.4.2-3: 20dB / 99% Bandwidth (8DPSK)

Frequency [MHz]	20dB Bandwidth [kHz]	99% Bandwidth [kHz]
2402	1320	1200
2441	1320	1192
2480	1312	1184

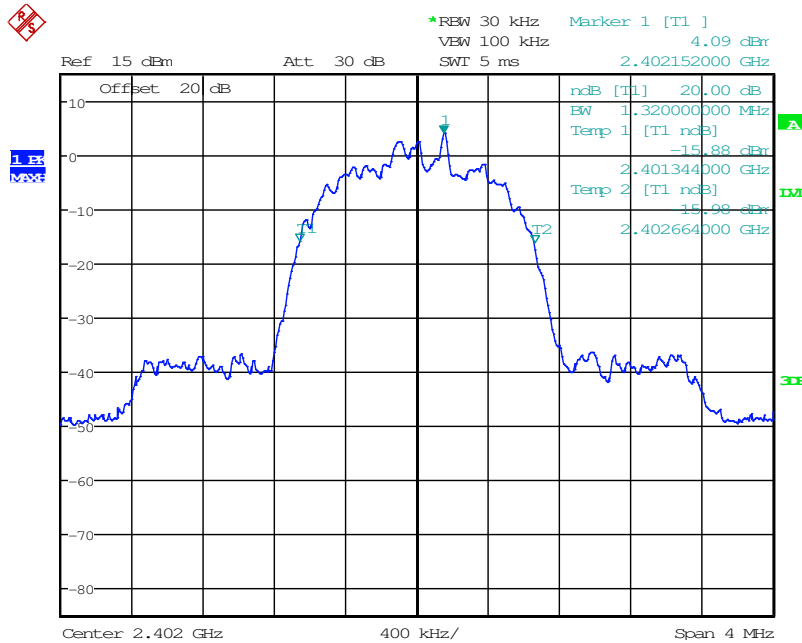

Date: 28.DEC.2015 22:46:49

Figure 7.4.4.2-13: 20dB BW Low Channel (8DPSK)

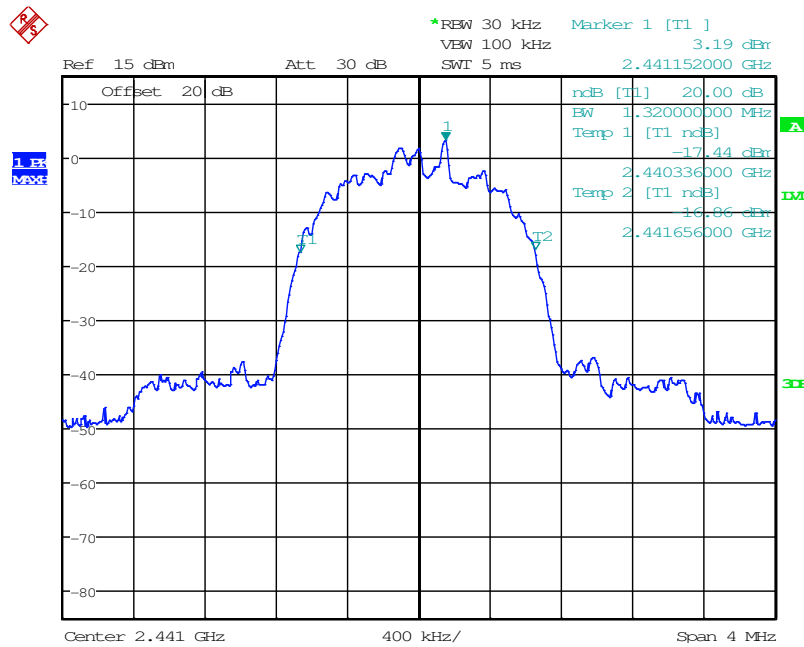

Date: 28.DEC.2015 22:37:00

Figure 7.4.4.2-14: 20dB BW Middle Channel (8DPSK)

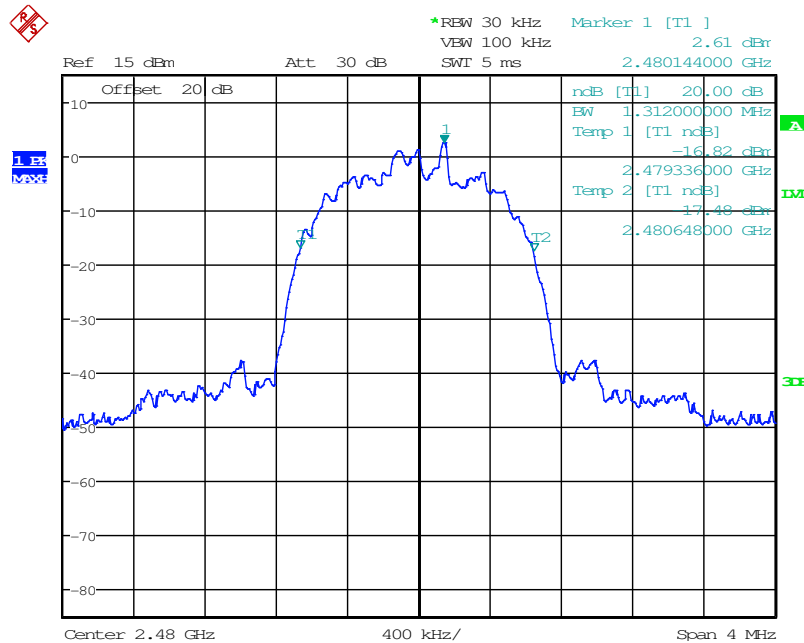

Date: 28.DEC.2015 22:33:37

Figure 7.4.4.2-15: 20dB BW High Channel (8DPSK)

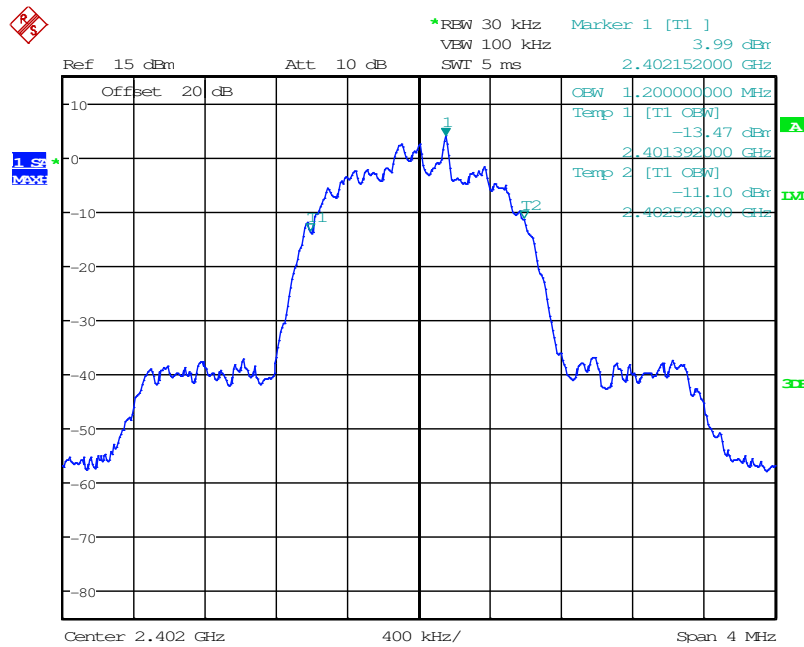

Date: 28.DEC.2015 22:22:12

Figure 7.4.4.2-16: 99% OBW Low Channel (8DPSK)

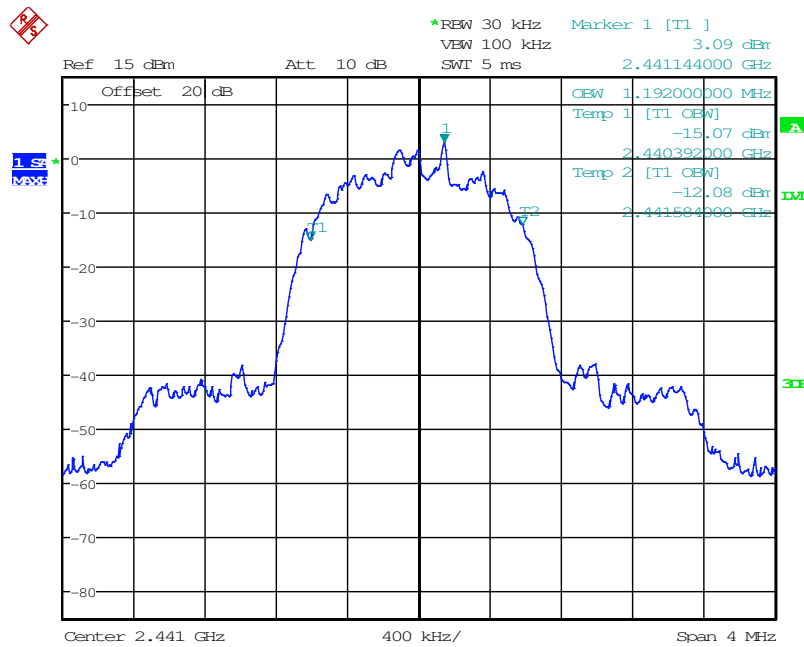

Date: 28.DEC.2015 22:11:54

Figure 7.4.4.2-17: 99% OBW Middle Channel (8DPSK)

7.5 Band-Edge Compliance and Spurious Emissions-FCC 15.247(d) IC: RSS-247 5.5

7.5.1 Band-Edge Compliance of RF Conducted Emissions

7.5.1.1 Measurement Procedure

The RF output port of the EUT was connected to the input of the spectrum analyzer through suitable attenuation. The EUT was investigated at the lowest and highest channel available to determine band-edge compliance. For each measurement the spectrum analyzer's RBW was set to 100 kHz, which is \geq 1% of the span, and the VBW was set to \geq 300 kHz.

7.5.1.2 Measurement Results

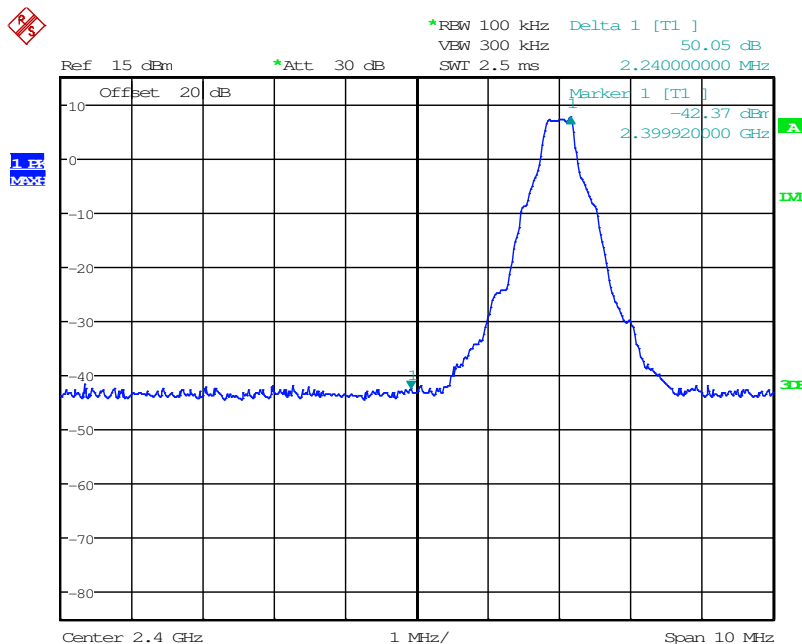

Date: 18.DEC.2015 20:00:43

Figure 7.5.1.2-1: Lower Band-edge (GFSK)

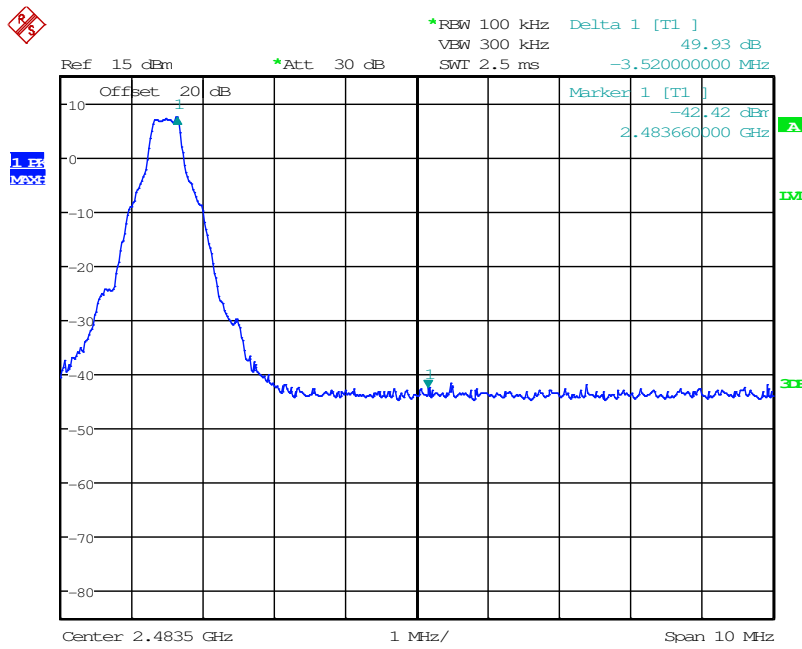

Date: 18.DEC.2015 17:34:52

Figure 7.5.1.2-2: Upper Band-edge (GFSK)

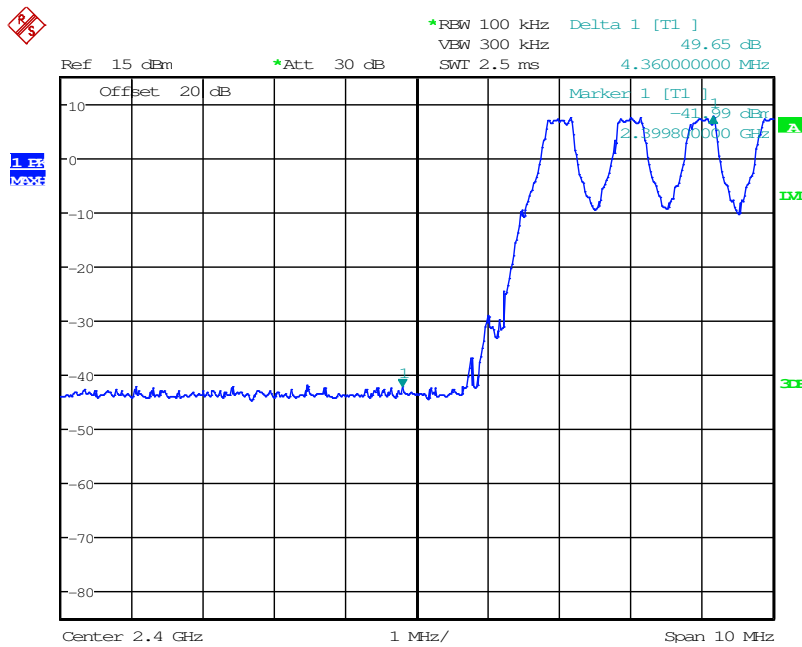

Date: 18.DEC.2015 20:06:37

Figure 7.5.1.2-3: Lower Band-edge – Hopping Mode (GFSK)

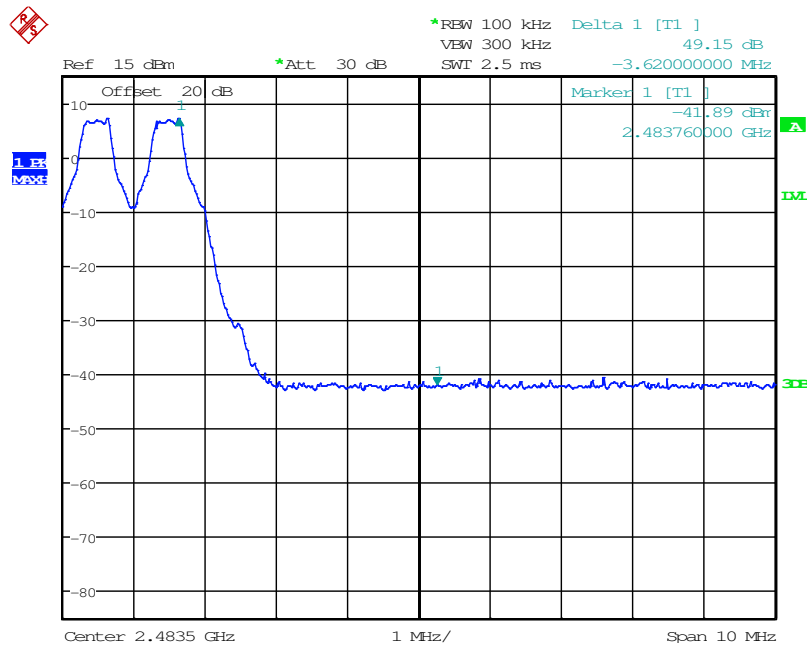

Date: 18.DEC.2015 19:46:08

Figure 7.5.1.2-4: Upper Band-edge – Hopping Mode (GFSK)

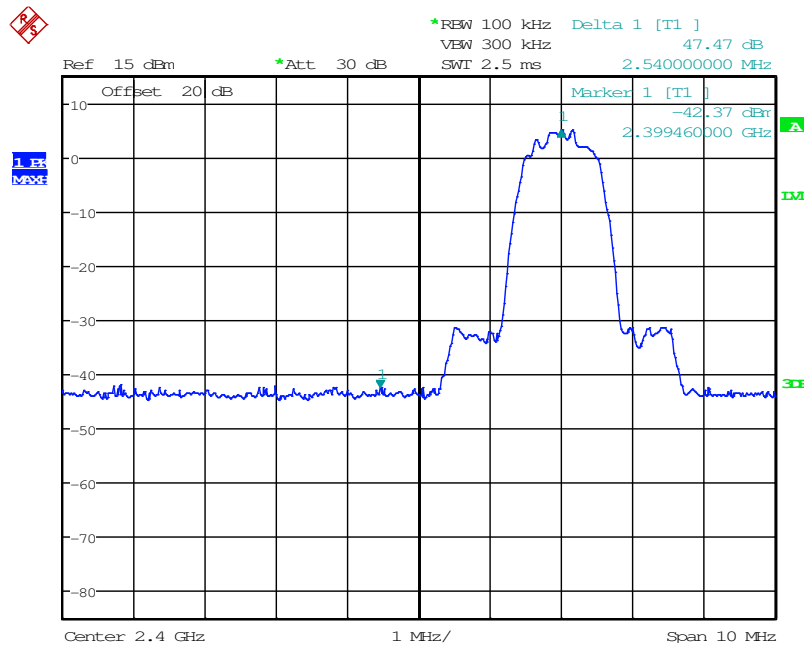

Date: 18.DEC.2015 17:03:28

Figure 7.5.1.2-5: Lower Band-edge ($\pi/4$ DQPSK)

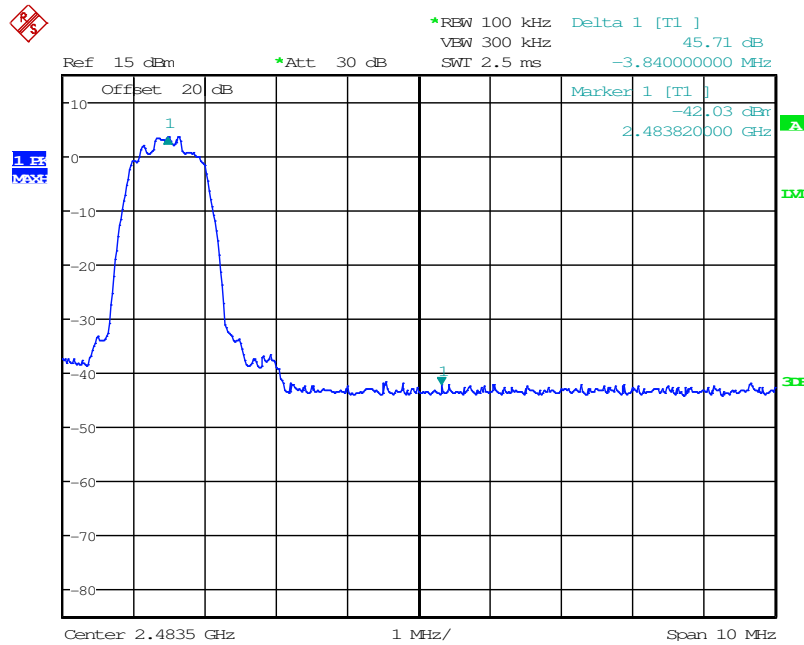

Date: 18.DEC.2015 17:32:11

Figure 7.5.1.2-6: Upper Band-edge ($\pi/4$ DQPSK)

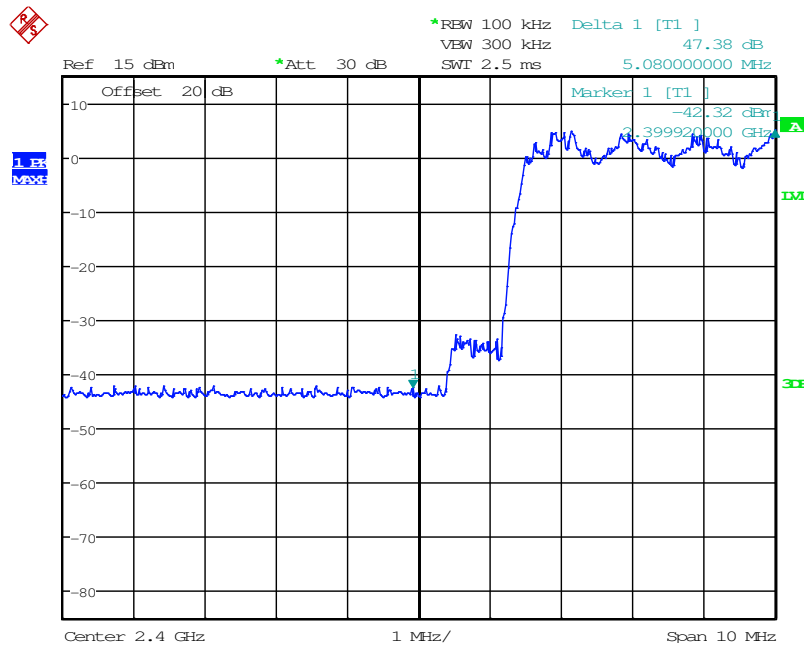

Date: 18.DEC.2015 17:10:01

Figure 7.5.1.2-7: Lower Band-edge – Hopping Mode ($\pi/4$ DQPSK)

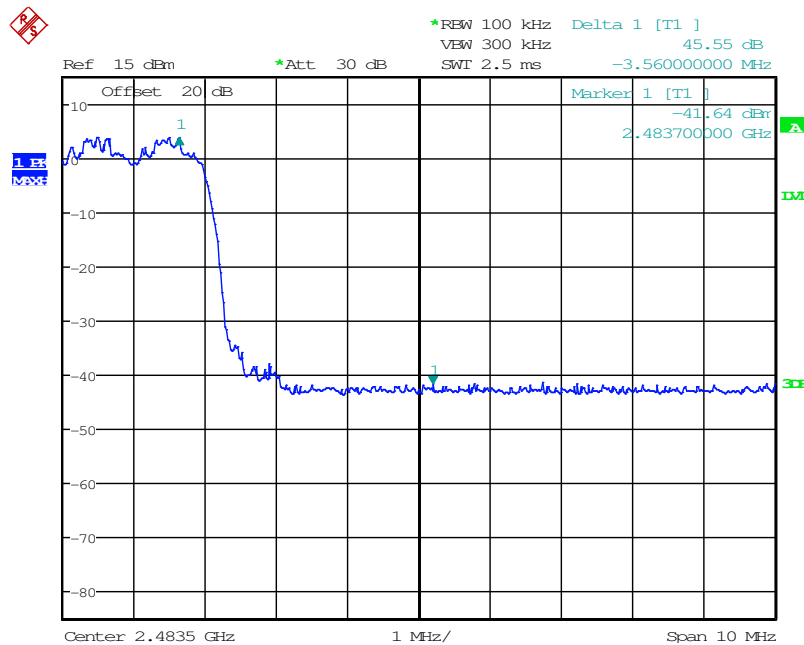

Date: 18.DEC.2015 17:26:53

Figure 7.5.1.2-8: Upper Band-edge – Hopping Mode ($\pi/4$ DQPSK)

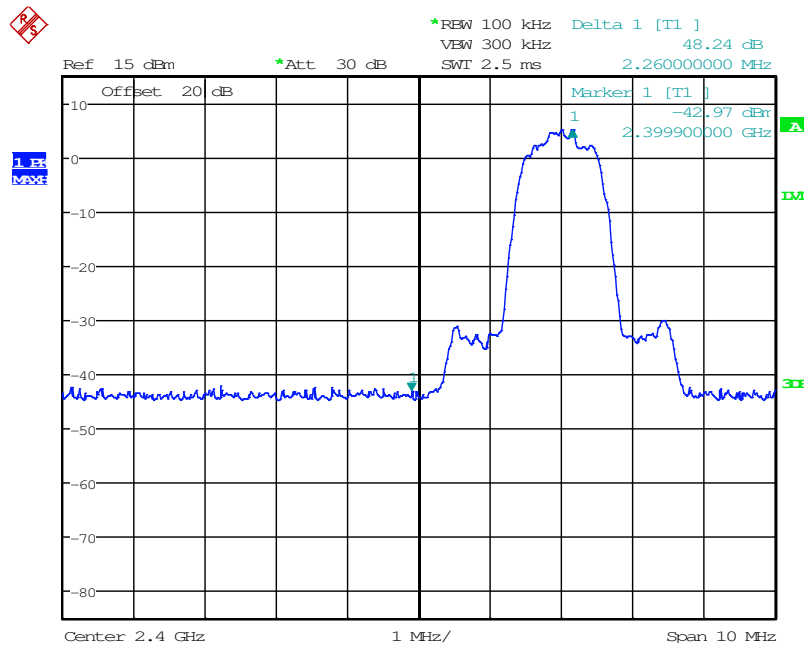

Date: 18.DEC.2015 16:58:52

Figure 7.5.1.2-9: Lower Band-edge (8DPSK)

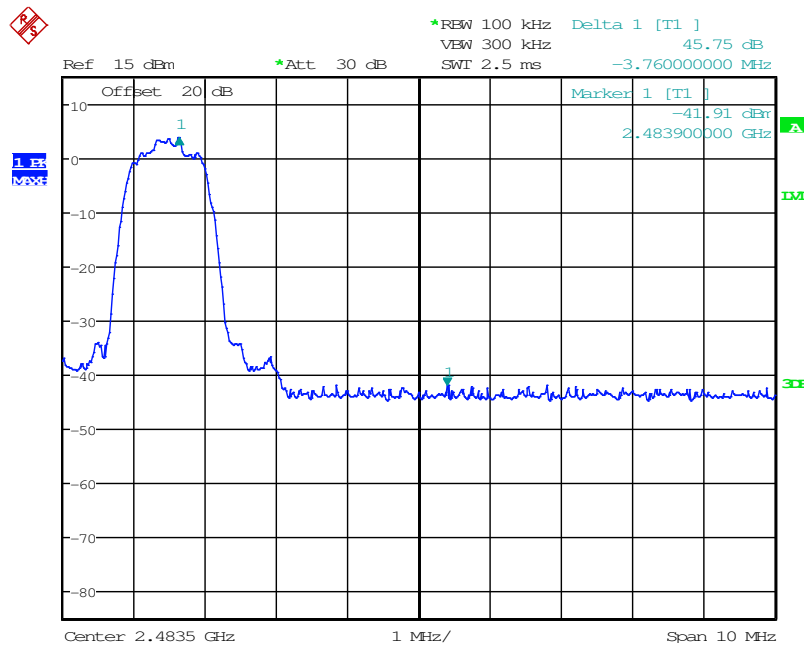

Date: 18.DEC.2015 16:40:22

Figure 7.5.1.2-10: Upper Band-edge (8DPSK)

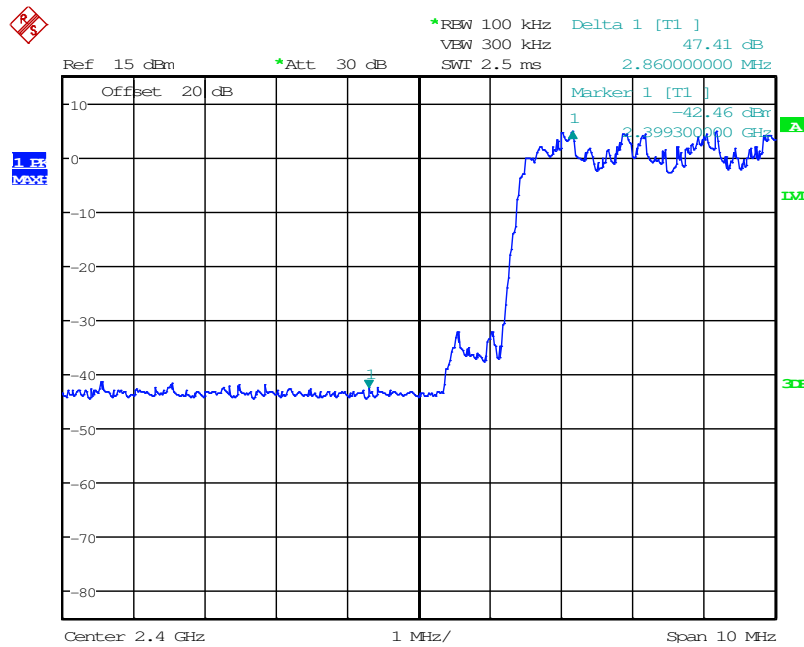

Date: 18.DEC.2015 16:54:53

Figure 7.5.1.2-11: Lower Band-edge – Hopping Mode (8DPSK)

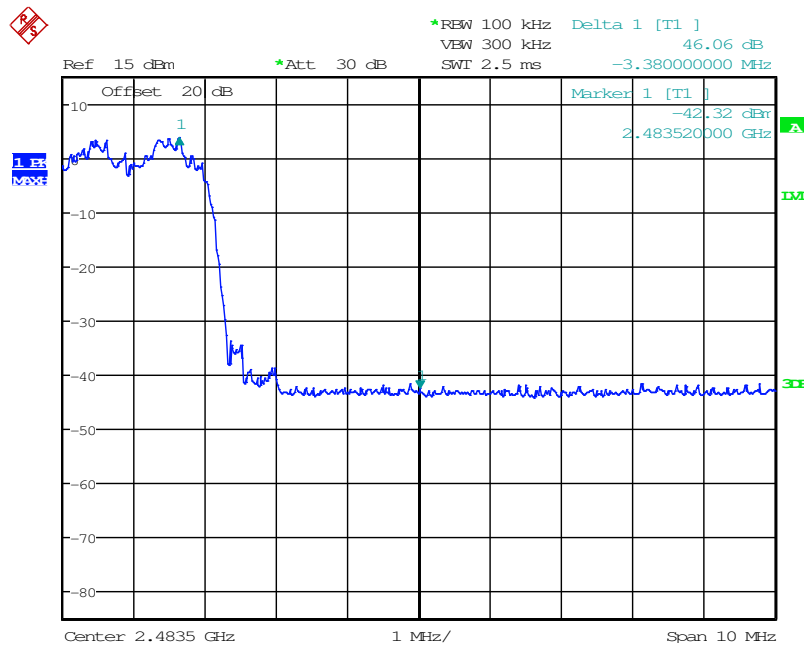

Date: 18.DEC.2015 16:48:22

Figure 7.5.1.2-12: Upper Band-edge – Hopping Mode (8DPSK)

7.5.2 RF Conducted Spurious Emissions

7.5.2.1 Measurement Procedure

The RF output port of the EUT was connected to the spectrum analyzer. The EUT was investigated for conducted spurious emissions from 30MHz to 26 GHz, 10 times the highest fundamental frequency. Measurements were made at the low, center and high channels of the EUT. For each measurement, the spectrum analyzer's RBW was set to 100 kHz. A peak detector function was used with the trace set to max hold. The levels were corrected for cable and attenuator losses.

7.5.2.2 Measurement Results

Results are shown below:

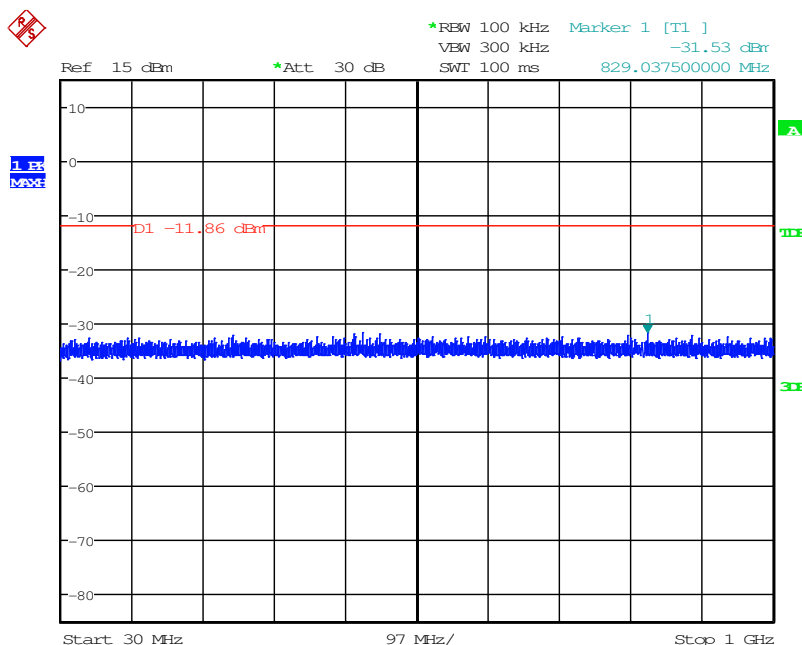

Date: 18.DEC.2015 11:46:28

Figure 7.5.2.2-1: 30 MHz – 1 GHz – Low Channel (GFSK)

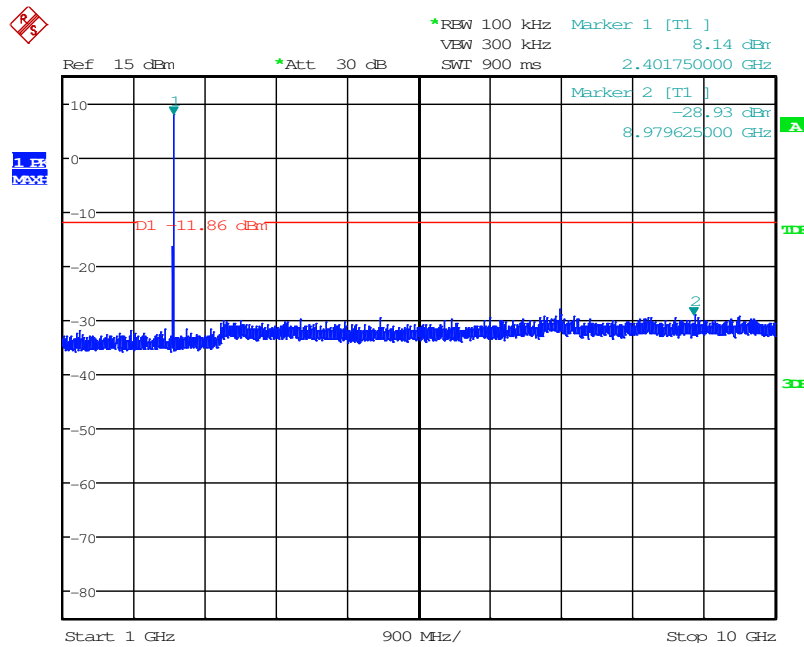

Date: 18.DEC.2015 11:37:02

Figure 7.5.2.2-2: 1 GHz –10 GHz – Low Channel (GFSK)

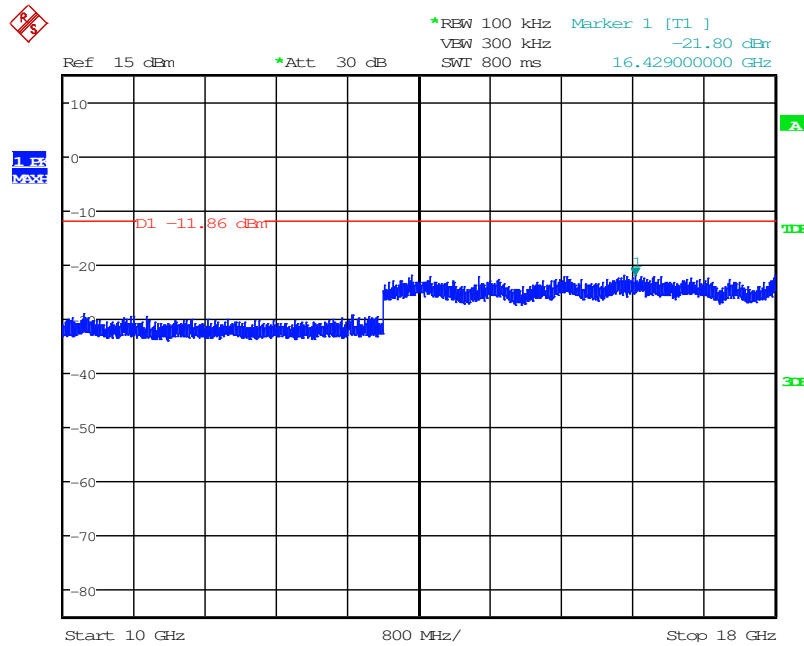

Date: 18.DEC.2015 11:39:22

Figure 7.5.2.2-3: 10 GHz –18 GHz – Low Channel (GFSK)

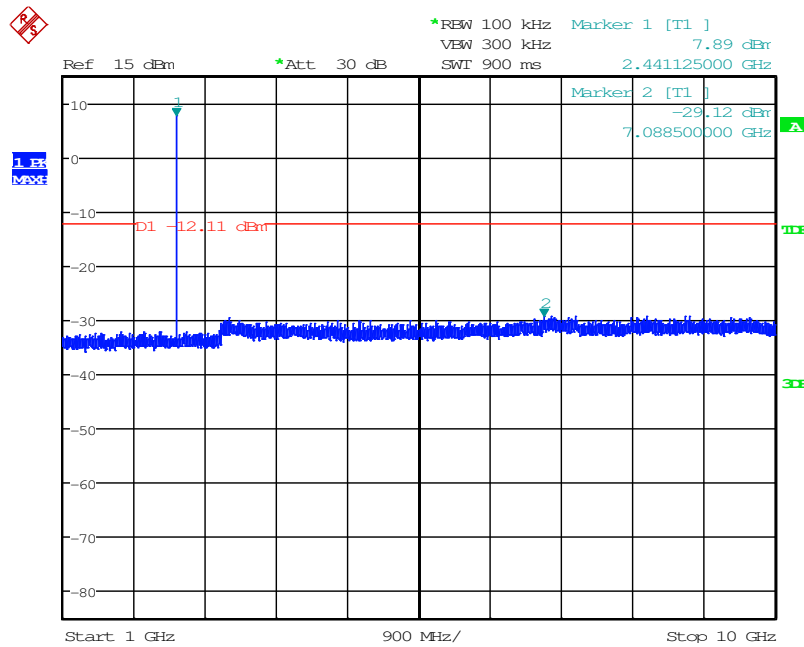

Date: 18.DEC.2015 11:56:44

Figure 7.5.2.2-6: 1 GHz –10 GHz – Middle Channel (GFSK)

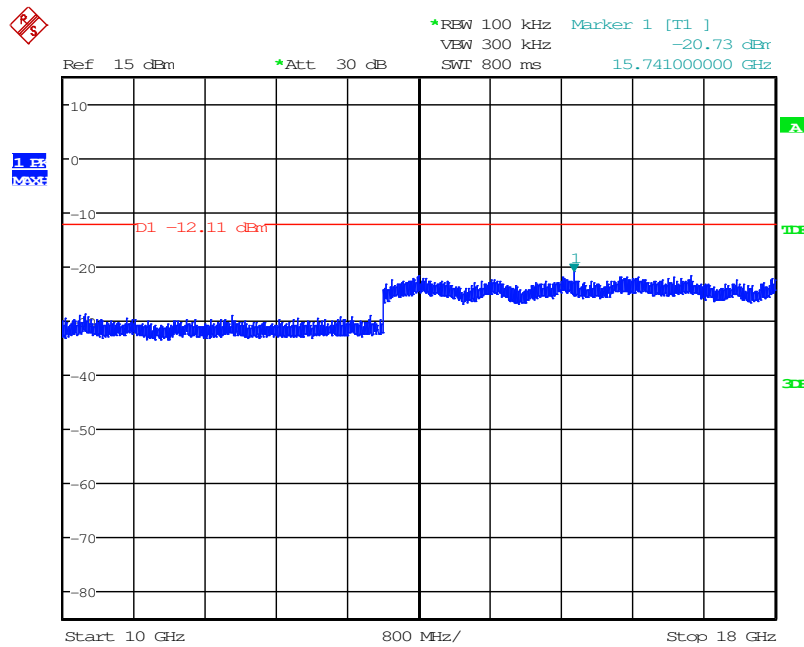

Date: 18.DEC.2015 12:01:33

Figure 7.5.2.2-7: 10 GHz –18 GHz – Middle Channel (GFSK)

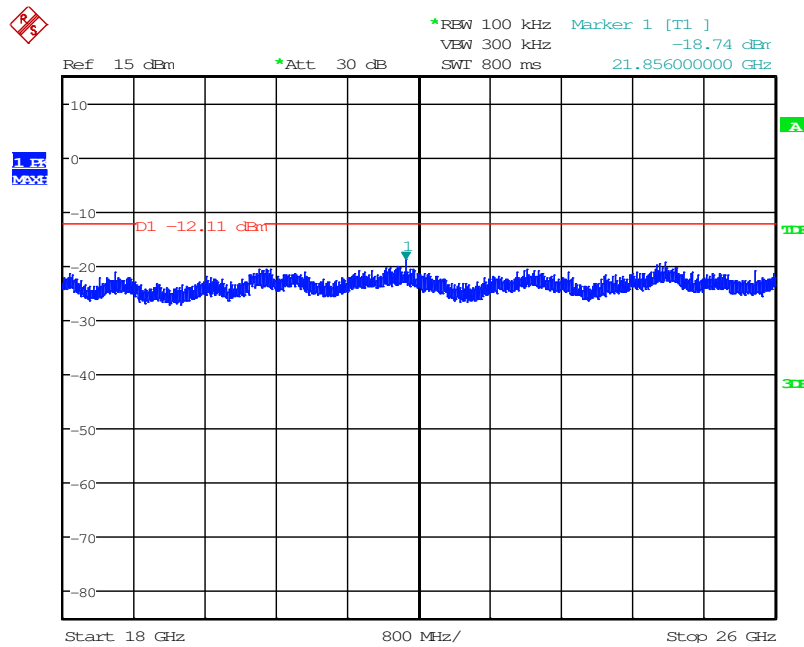

Date: 18.DEC.2015 12:04:25

Figure 7.5.2.2-8: 18 GHz –26 GHz – Middle Channel (GFSK)

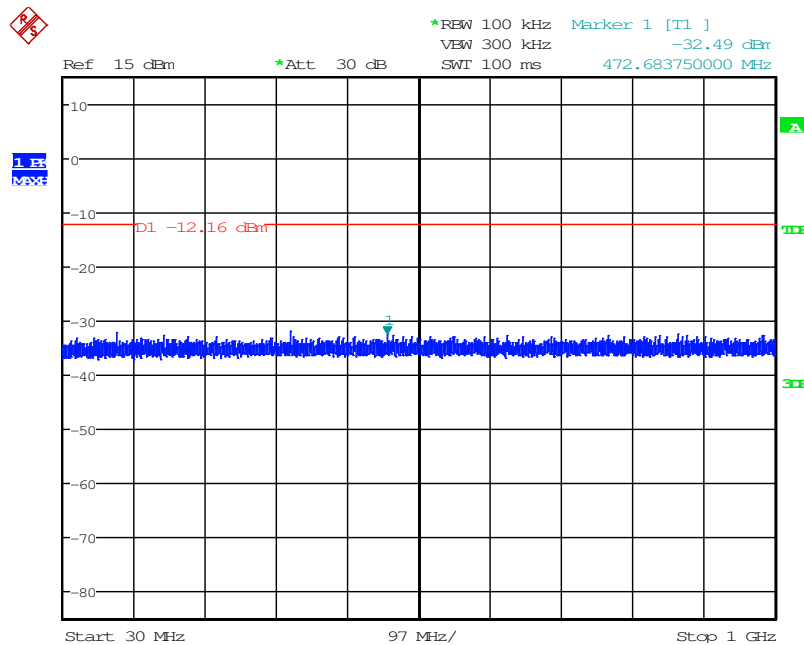

Date: 18.DEC.2015 12:31:10

Figure 7.5.2.2-9: 30 MHz – 1 GHz – High Channel (GFSK)

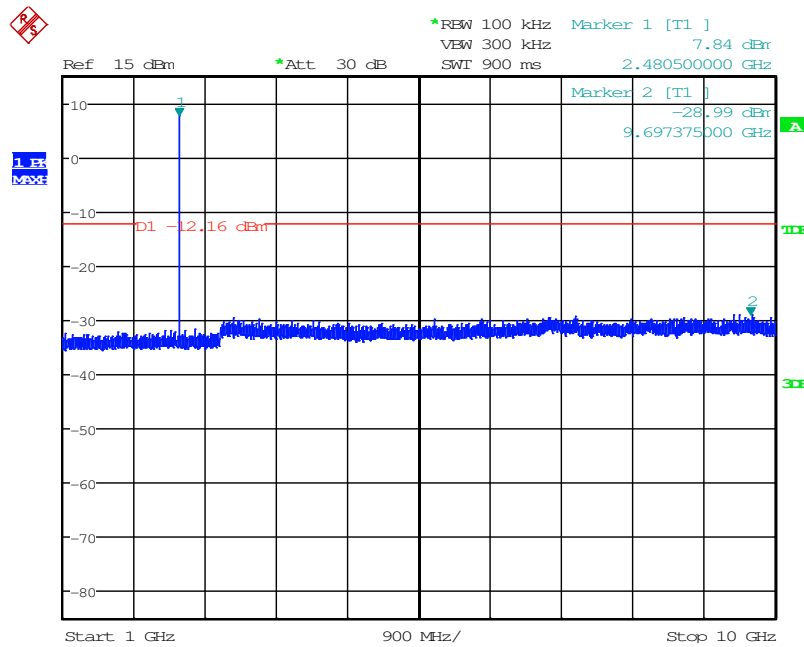

Date: 18.DEC.2015 12:17:11

Figure 7.5.2.2-10: 1 GHz –10 GHz –High Channel (GFSK)

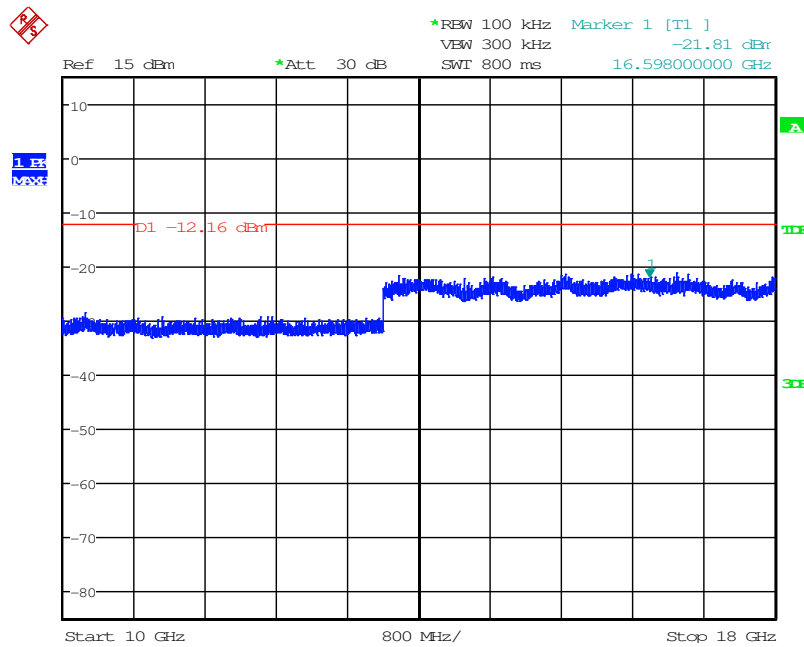

Date: 18.DEC.2015 12:25:19

Figure 7.5.2.2-11: 10 GHz –18 GHz – High Channel (GFSK)

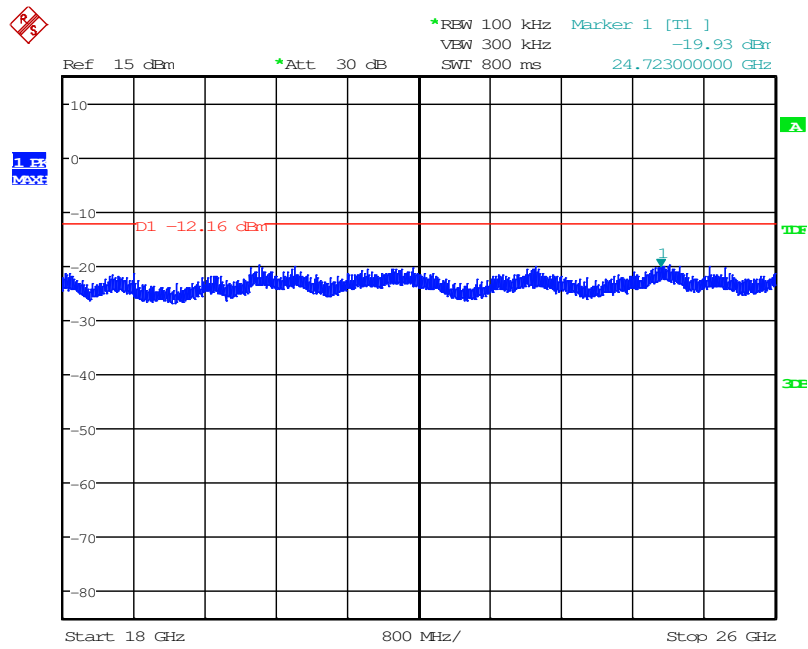

Date: 18.DEC.2015 12:29:01

Figure 7.5.2.2-12: 18 GHz –26 GHz – High Channel (GFSK)

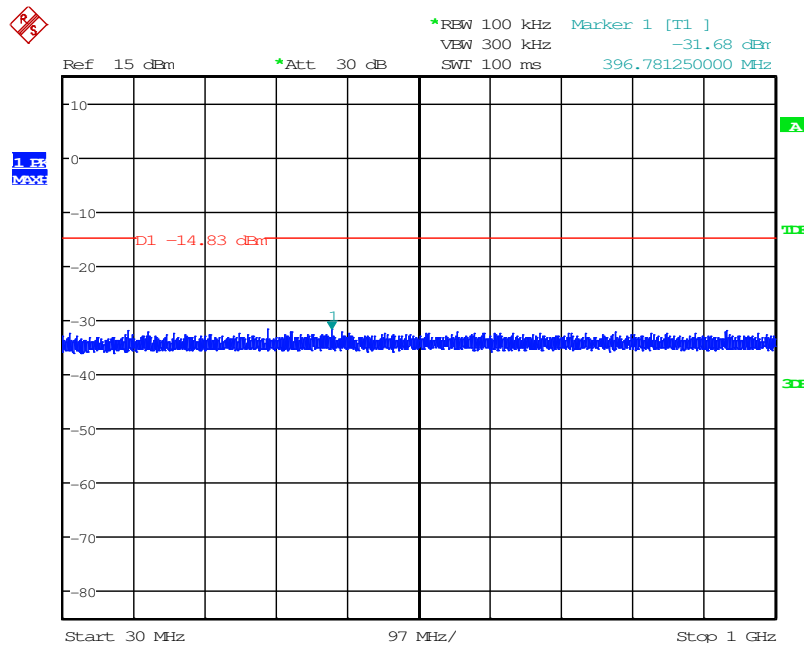

Date: 18.DEC.2015 13:30:46

Figure 7.5.2.2-13: 30 MHz – 1 GHz – Low Channel ($\pi/4$ DQPSK)

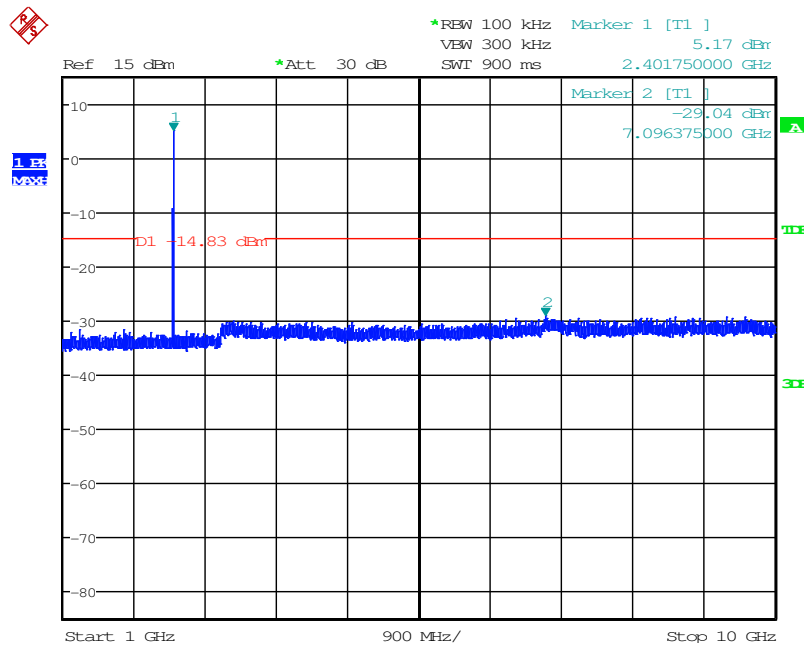

Date: 18.DEC.2015 12:56:03

Figure 7.5.2.2-14: 1 GHz –10 GHz – Low Channel ($\pi/4$ DQPSK)

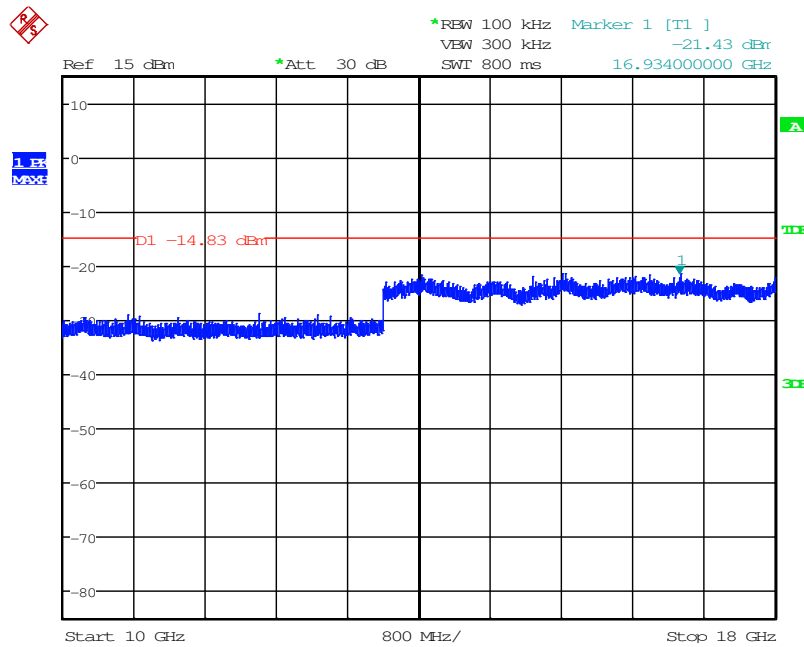

Date: 18.DEC.2015 12:59:55

Figure 7.5.2.2-15: 103 GHz -18 GHz – Low Channel ($\pi/4$ DQPSK)

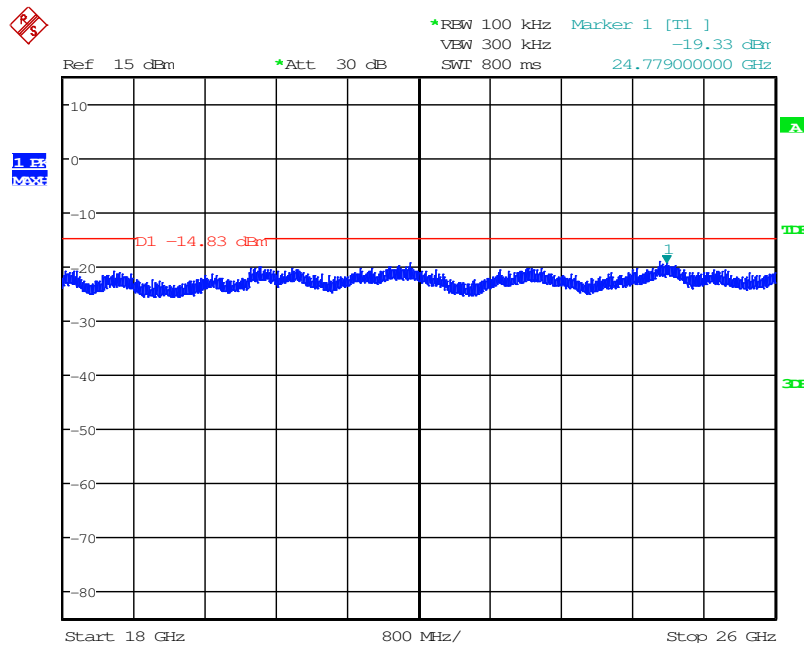

Date: 18.DEC.2015 13:21:23

Figure 7.5.2.2-16: 18 GHz -26 GHz – Low Channel ($\pi/4$ DQPSK)

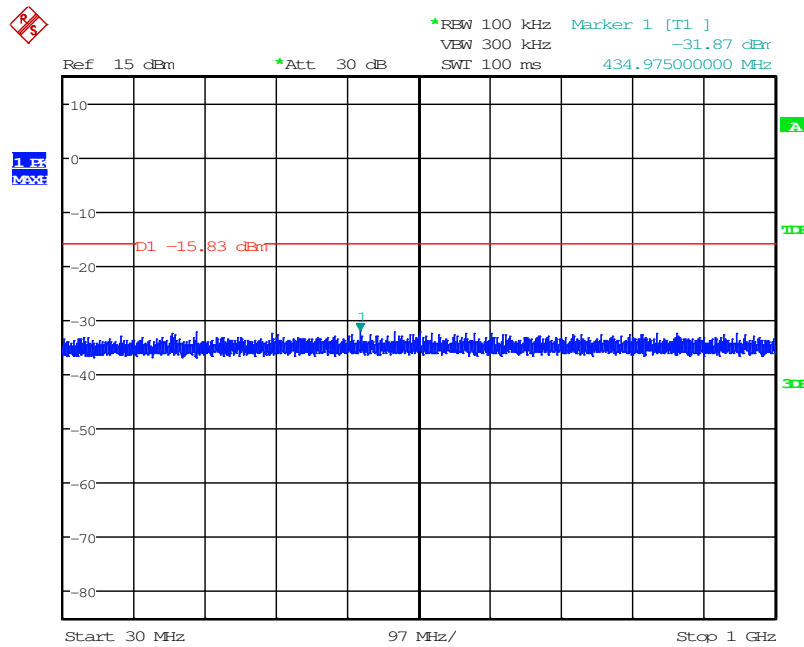

Date: 18.DEC.2015 14:29:57

Figure 7.5.2.2-17: 30 MHz – 1 GHz –Middle Channel ($\pi/4$ DQPSK)

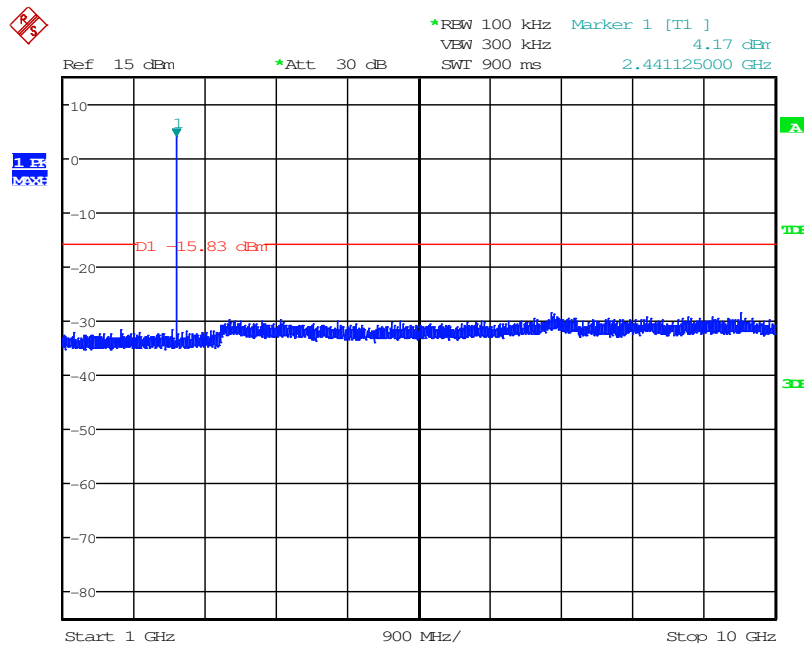

Date: 18.DEC.2015 13:42:43

Figure 7.5.2.2-18: 1 GHz –10 GHz – Middle Channel ($\pi/4$ DQPSK)

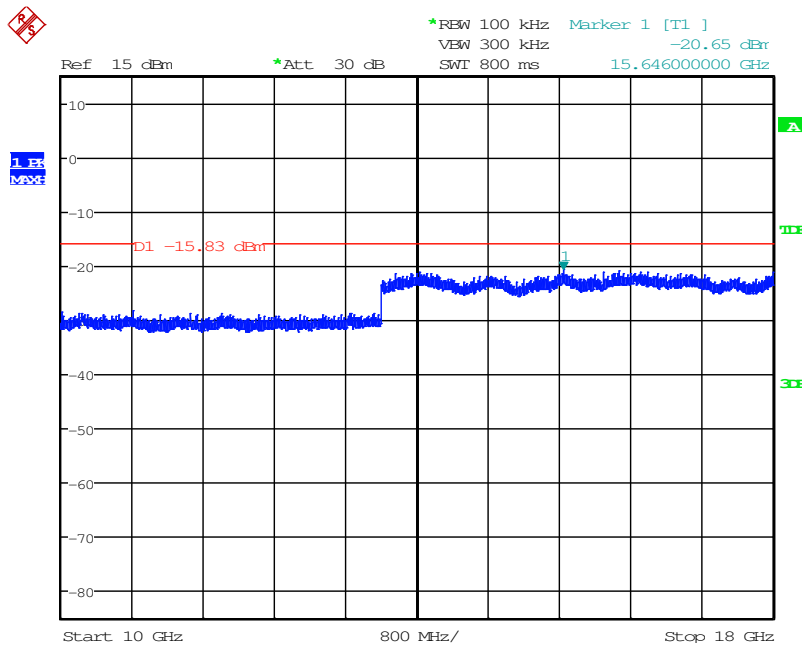

Date: 18.DEC.2015 14:22:49

Figure 7.5.2.2-19: 10 GHz –18 GHz – Middle Channel ($\pi/4$ DQPSK)

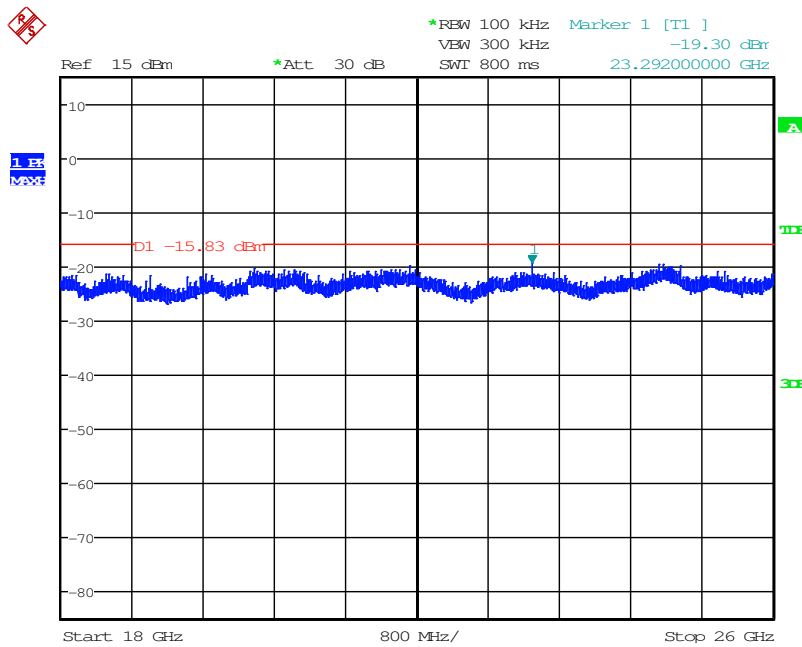

Date: 18.DEC.2015 14:27:09

Figure 7.5.2.2-20: 18 GHz –26 GHz – Middle Channel ($\pi/4$ DQPSK)

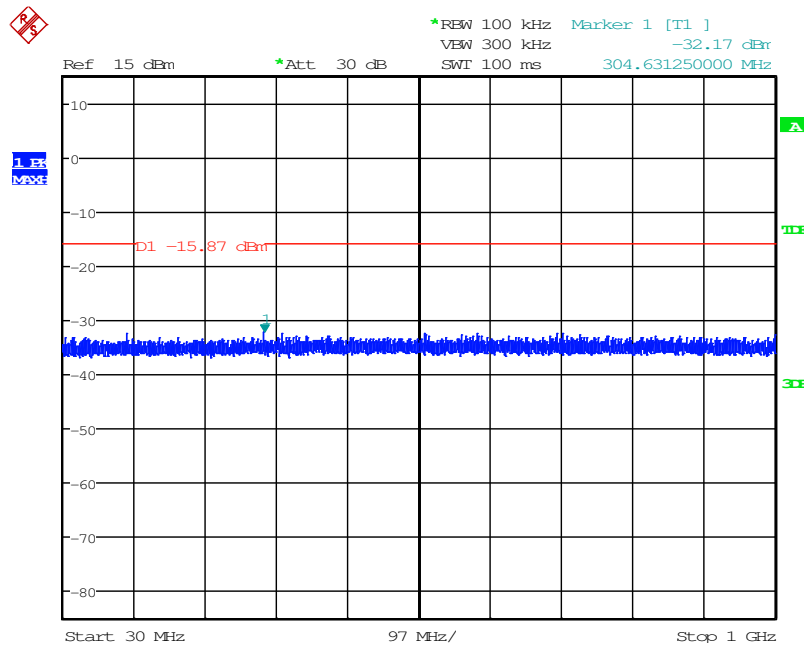

Date: 18.DEC.2015 14:54:59

Figure 7.5.2.2-21: 30 MHz – 1 GHz – High Channel ($\pi/4$ DQPSK)

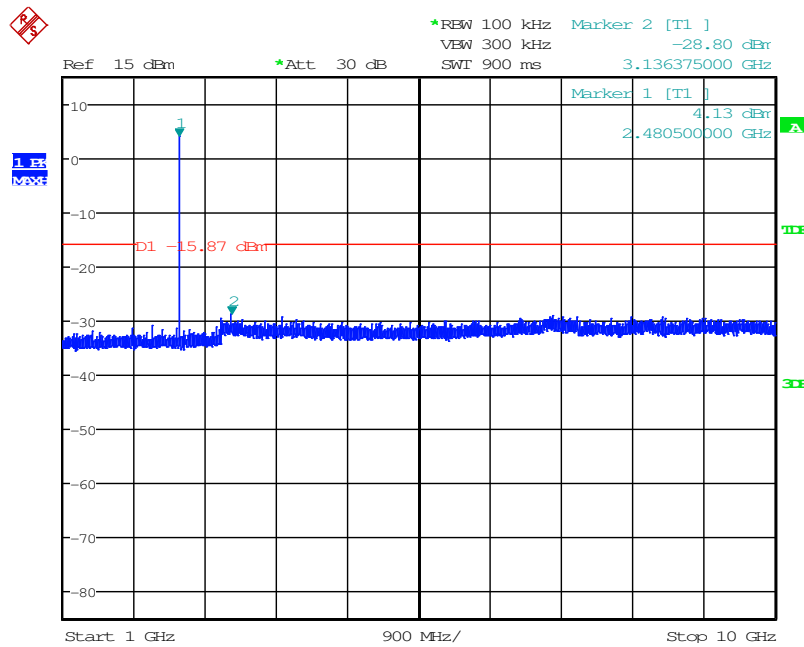

Date: 18.DEC.2015 14:43:29

Figure 7.5.2.2-22: 1 GHz –10 GHz –High Channel ($\pi/4$ DQPSK)

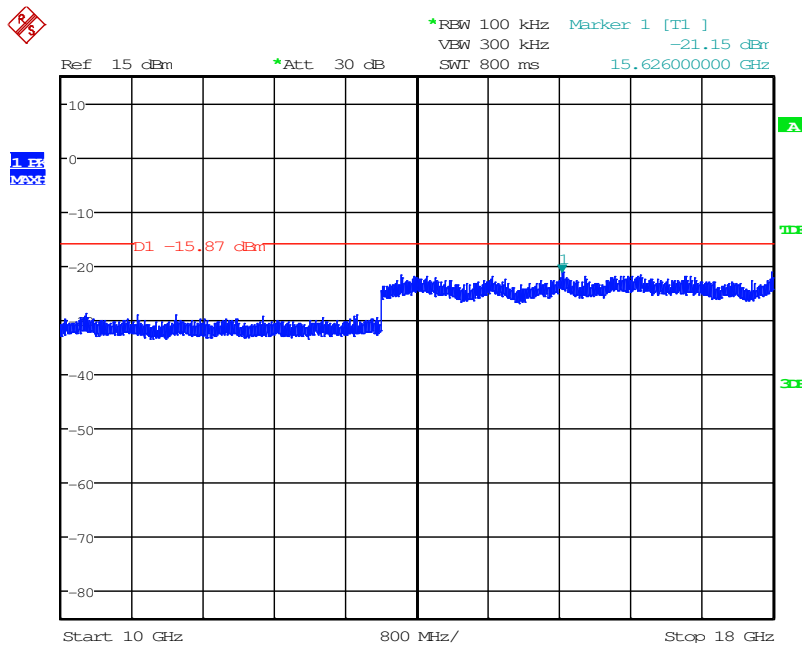

Date: 18.DEC.2015 14:48:26

Figure 7.5.2.2-23: 10 GHz –18 GHz – High Channel ($\pi/4$ DQPSK)

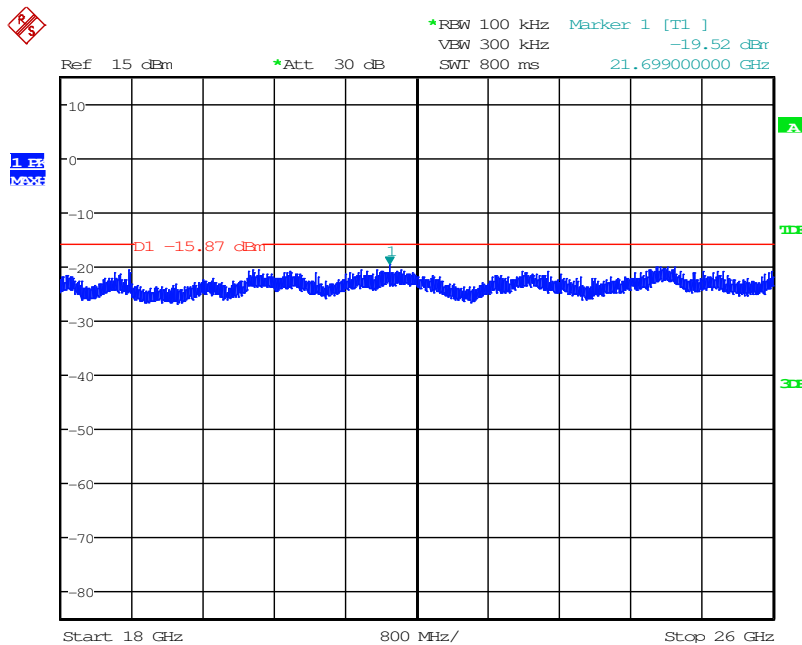

Date: 18.DEC.2015 14:52:11

Figure 7.5.2.2-24: 18 GHz –26 GHz – High Channel ($\pi/4$ DQPSK)

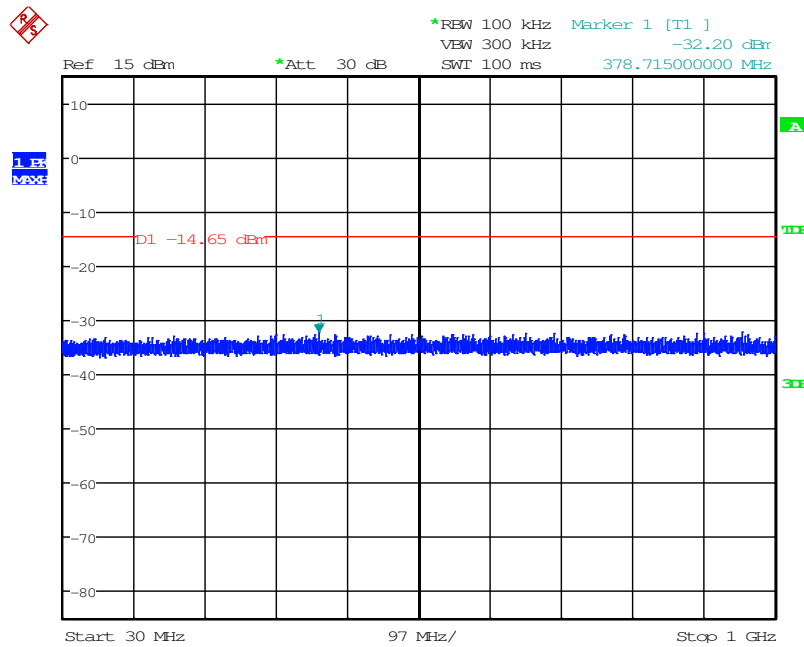

Date: 18.DEC.2015 15:13:49

Figure 7.5.2.2-25: 30 MHz – 1 GHz – Low Channel (8DPSK)

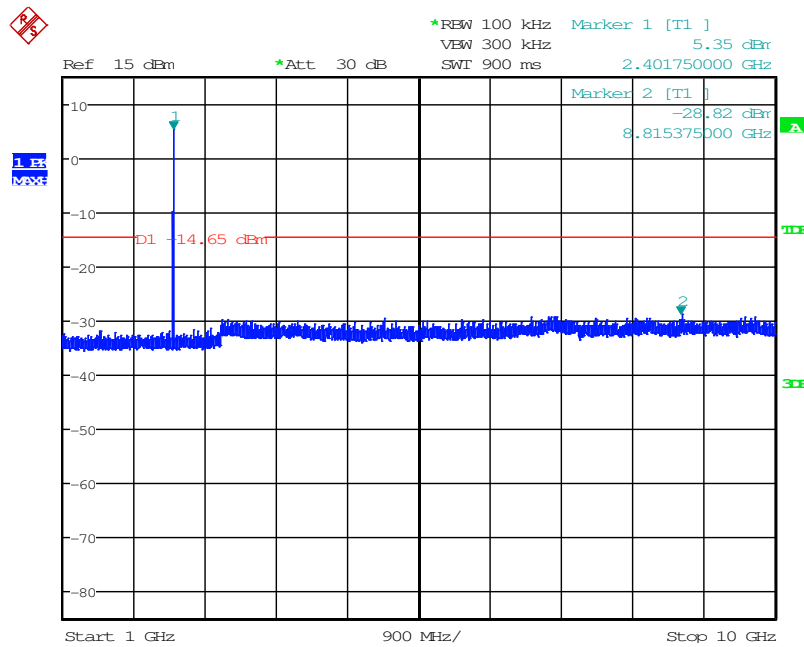

Date: 18.DEC.2015 15:04:31

Figure 7.5.2.2-26: 1 GHz – 10 GHz – Low Channel (8DPSK)

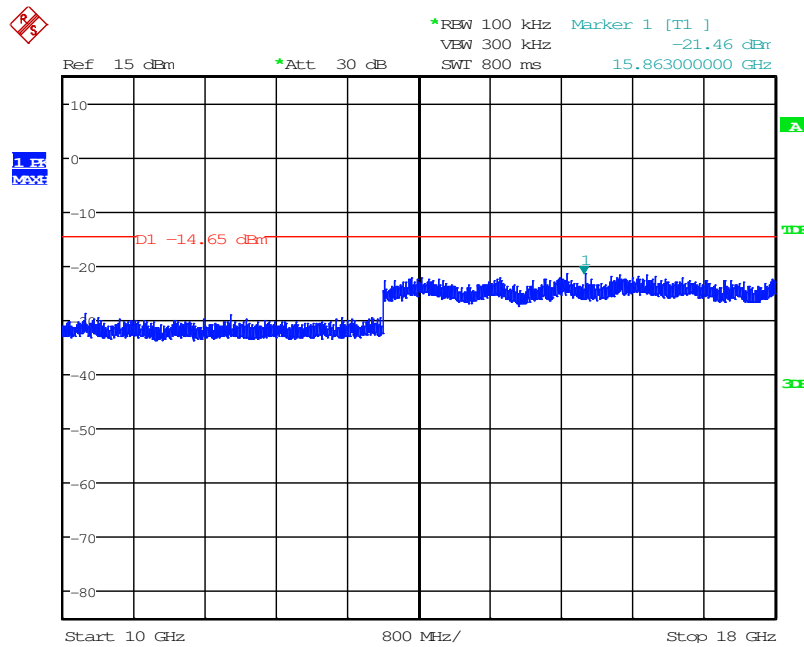

Date: 18.DEC.2015 15:08:05

Figure 7.5.2.2-27: 10 GHz –18 GHz – Low Channel (8DPSK)

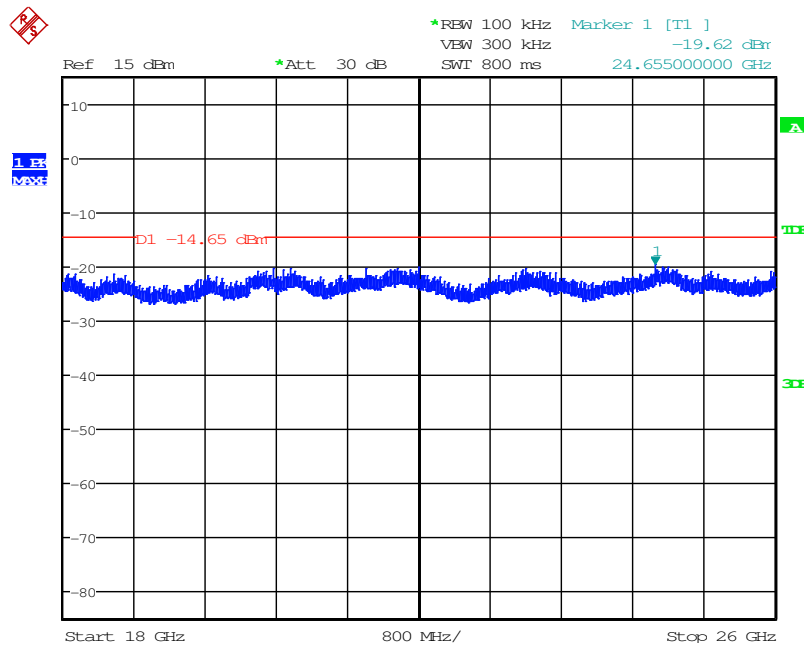

Date: 18.DEC.2015 15:10:49

Figure 7.5.2.2-28: 18 GHz –26 GHz – Low Channel (8DPSK)

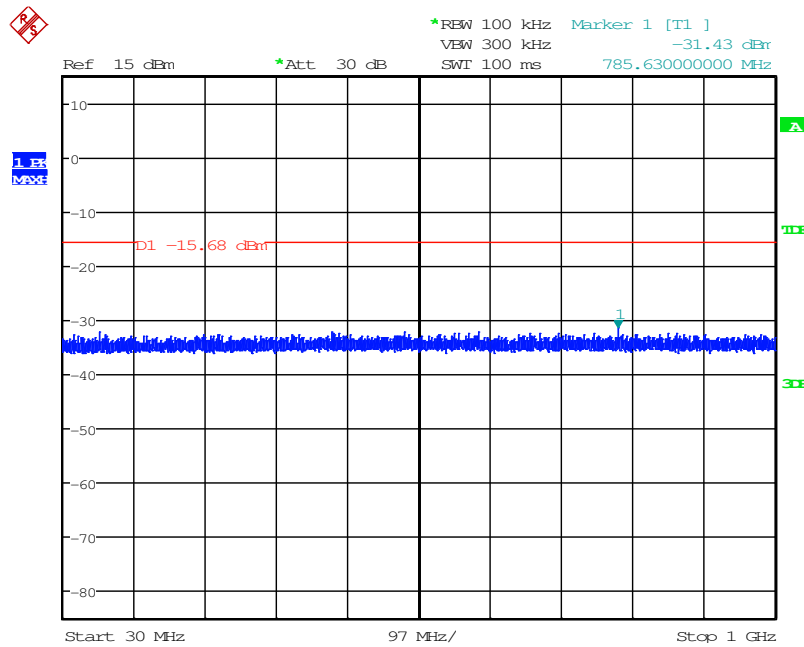

Date: 18.DEC.2015 15:52:27

Figure 7.5.2.2-29: 30 MHz – 1 GHz –Middle Channel (8DPSK)

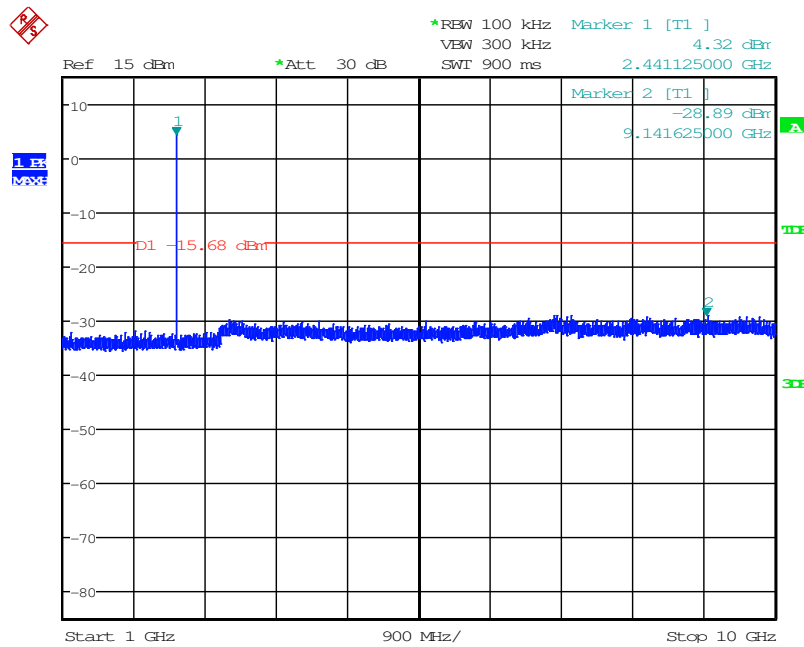

Date: 18.DEC.2015 15:28:09

Figure 7.5.2.2-30: 1 GHz –10 GHz – Middle Channel (8DPSK)

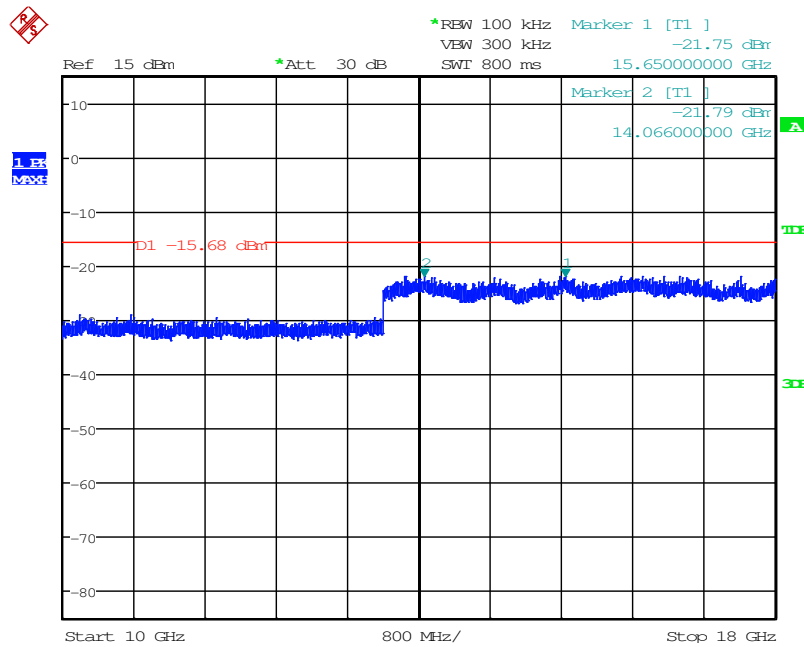

Date: 18.DEC.2015 15:31:54

Figure 7.5.2.2-31: 10 GHz –18 GHz – Middle Channel (8DPSK)

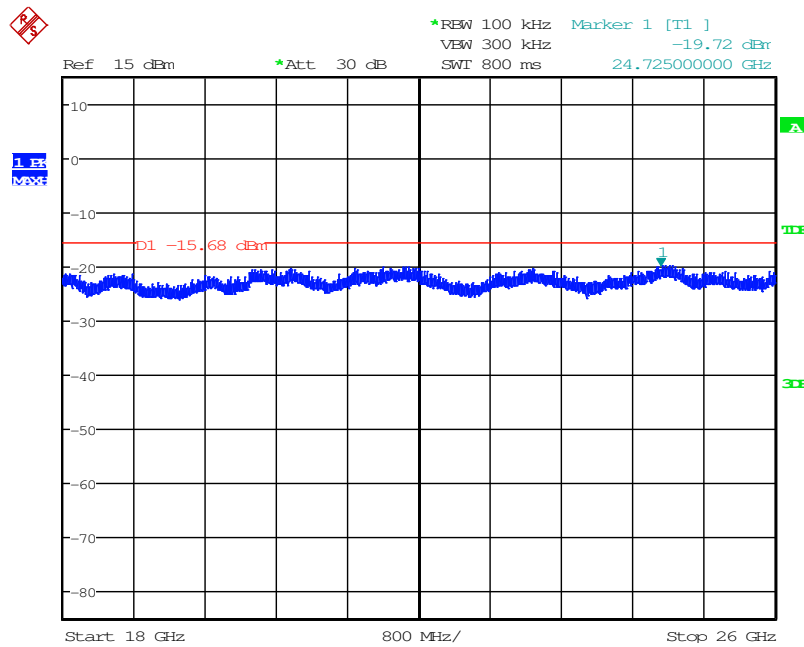

Date: 18.DEC.2015 15:46:02

Figure 7.5.2.2-32: 18 GHz –26 GHz – Middle Channel (8DPSK)

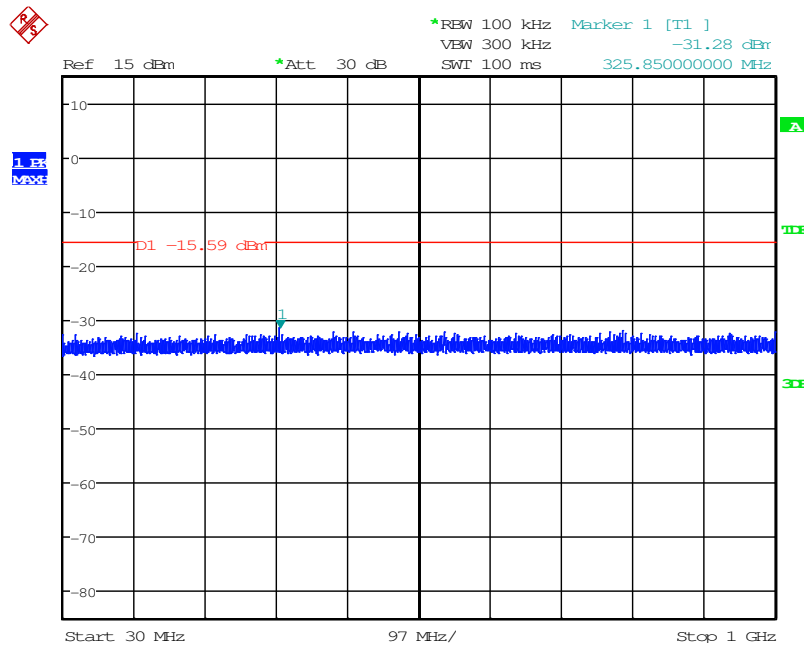

Date: 18.DEC.2015 16:32:44

Figure 7.5.2.2-33: 30 MHz – 1 GHz – High Channel (8DPSK)

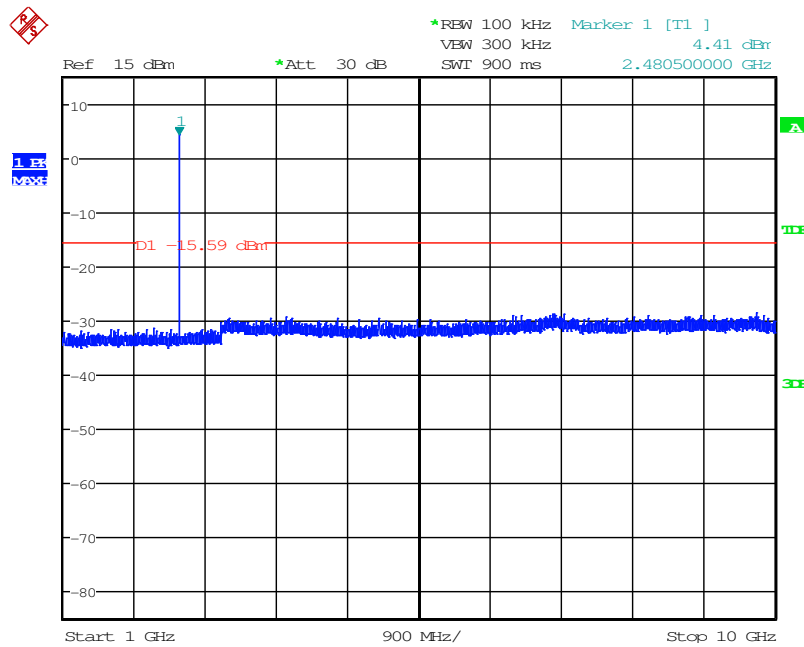

Date: 18.DEC.2015 16:21:46

Figure 7.5.2.2-34: 1 GHz –10 GHz –High Channel (8DPSK)

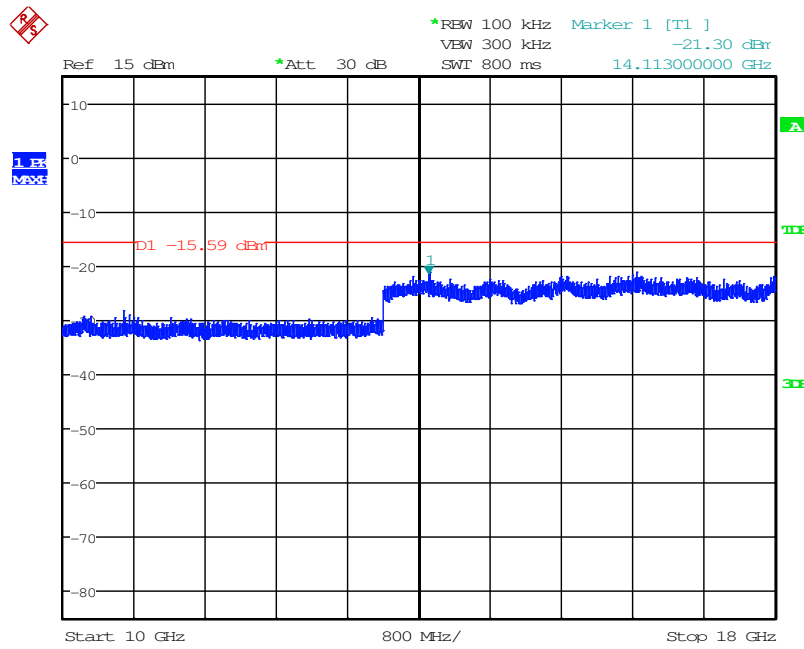

Date: 18.DEC.2015 16:25:21

Figure 7.5.2.2-35: 10 GHz –18 GHz – High Channel (8DPSK)

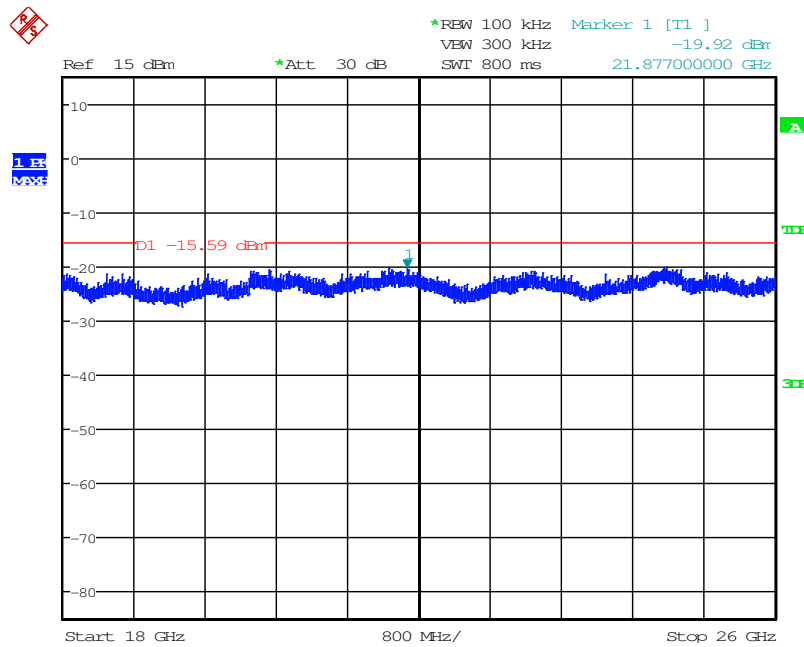

Date: 18.DEC.2015 16:28:16

Figure 7.5.2.2-36: 18 GHz –26 GHz – High Channel (8DPSK)

7.5.3 Radiated Spurious Emissions within the Restricted Bands - FCC Sections 15.205, 15.209; IC: RSS-Gen 8.9, 8.10

7.5.3.1 Measurement Procedure

Radiated emissions tests were made over the frequency range of 9 kHz to 26 GHz, 10 times the highest fundamental frequency. Each emission found to be in a restricted band as defined by section 15.205, including any emission at the operational band-edge, was compared to the radiated emission limits as defined in section 15.209.

For measurements below 30 MHz, the receive antenna height was set to 1m and the EUT was rotated through 360 degrees. The resolution bandwidth was set to 200 Hz below 150 kHz and to 9 kHz above 150 kHz.

For measurements above 30 MHz, the EUT was rotated through 360° and the receive antenna height was varied from 1m to 4m so that the maximum radiated emissions level would be detected. For frequencies below 1000MHz, quasi-peak measurements were made using a resolution bandwidth RBW of 120 kHz and a video bandwidth VBW of 300 kHz. For frequencies above 1000 MHz, peak measurements were made with RBW and VBW of 1 MHz and 3 MHz respectively. Average measurements were collected in the linear amplitude scale with VBW of 30 Hz.

The EUT was caused to generate a continuous carrier signal on the hopping channel.

7.5.3.2 Measurement Results

Band-edge and radiated spurious emissions found in the restricted bands of 9 kHz to 26 GHz are reported in the tables below.

Table 7.5.3.2-1: Radiated Spurious Emissions Tabulated Data - GFSK

Frequency (MHz)	Level (dBuV)		Antenna Polarity (H/V)	Correction Factors (dB)	Corrected Level (dBuV/m)		Limit (dBuV/m)		Margin (dB)	
	pk	Qpk/Avg			pk	Qpk/Avg	pk	Qpk/Avg	pk	Qpk/Avg
Low Channel = 2402 MHz										
2390	50.95	39.67	H	0.31	51.26	39.98	74.0	54.0	22.7	14.0
2390	50.56	39.58	V	0.31	50.87	39.89	74.0	54.0	23.1	14.1
4804	39.05	29.81	H	8.53	47.58	38.34	74.0	54.0	26.4	15.7
4804	40.34	31.00	V	8.53	48.87	39.53	74.0	54.0	25.1	14.5
Middle Channel = 2441 MHz										
4882	36.69	26.75	H	8.81	45.50	35.56	74.0	54.0	28.5	18.4
4882	37.17	26.59	V	8.81	45.98	35.40	74.0	54.0	28.0	18.6
High Channel = 2480 MHz										
2483.5	55.64	50.73	H	0.79	56.43	51.52	74.0	54.0	17.6	2.5
2483.5	54.38	49.33	V	0.79	55.17	50.12	74.0	54.0	18.8	3.9
4960	38.70	28.97	H	9.09	47.79	38.06	74.0	54.0	26.2	15.9
4960	39.68	29.82	V	9.09	48.77	38.91	74.0	54.0	25.2	15.1

Note: All emissions above 4.96 GHz were attenuated below the limits and the noise floor of the measurement equipment.

Table 7.5.3.2-2: Radiated Spurious Emissions Tabulated Data – ($\pi/4$) DQPSK

Frequency (MHz)	Level (dBuV)		Antenna Polarity (H/V)	Correction Factors (dB)	Corrected Level (dBuV/m)		Limit (dBuV/m)		Margin (dB)	
	pk	Qpk/Avg			pk	Qpk/Avg	pk	Qpk/Avg	pk	Qpk/Avg
Low Channel = 2402 MHz										
4804	37.42	27.38	H	8.53	45.95	35.91	74.0	54.0	28.0	18.1
4804	37.49	28.16	V	8.53	46.02	36.69	74.0	54.0	28.0	17.3
Middle Channel = 2441 MHz										
4882	37.54	26.98	H	8.81	46.35	35.79	74.0	54.0	27.6	18.2
4882	36.93	26.47	V	8.81	45.74	35.28	74.0	54.0	28.3	18.7
High Channel = 2480 MHz										
2483.5	54.31	48.36	H	0.79	55.10	49.15	74.0	54.0	18.9	4.9
2483.5	52.88	46.65	V	0.79	53.67	47.44	74.0	54.0	20.3	6.6
4960	37.65	26.93	H	9.09	46.74	36.02	74.0	54.0	27.3	18.0
4960	37.26	27.22	V	9.09	46.35	36.31	74.0	54.0	27.6	17.7

Note: All emissions above 4.96 GHz were attenuated below the limits and the noise floor of the measurement equipment.

Table 7.5.3.2-3: Radiated Spurious Emissions Tabulated Data – 8DPSK

Frequency (MHz)	Level (dBuV)		Antenna Polarity (H/V)	Correction Factors (dB)	Corrected Level (dBuV/m)		Limit (dBuV/m)		Margin (dB)	
	pk	Qpk/Avg			pk	Qpk/Avg	pk	Qpk/Avg	pk	Qpk/Avg
Low Channel = 2402 MHz										
4804	37.48	27.48	H	8.53	46.01	36.01	74.0	54.0	28.0	18.0
4804	38.50	28.30	V	8.53	47.03	36.83	74.0	54.0	27.0	17.2
Middle Channel = 2441 MHz										
4882	37.12	26.73	H	8.81	45.93	35.54	74.0	54.0	28.1	18.5
4882	37.08	26.77	V	8.81	45.89	35.58	74.0	54.0	28.1	18.4
High Channel = 2480 MHz										
2483.5	54.48	48.34	H	0.79	55.27	49.13	74.0	54.0	18.7	4.9
2483.5	52.14	46.16	V	0.79	52.93	46.95	74.0	54.0	21.1	7.1
4960	36.84	26.85	H	9.09	45.93	35.94	74.0	54.0	28.1	18.1
4960	36.93	27.01	V	9.09	46.02	36.10	74.0	54.0	28.0	17.9

Note: All emissions above 4.96 GHz were attenuated below the limits and the noise floor of the measurement equipment.

7.5.3.3 Sample Calculation:

$$R_C = R_U + CF_T$$

Where:

CF_T	=	Total Correction Factor (AF+CA+AG)-DC (Average Measurements Only)
R_U	=	Uncorrected Reading
R_C	=	Corrected Level
AF	=	Antenna Factor
CA	=	Cable Attenuation
AG	=	Amplifier Gain
DC	=	Duty Cycle Correction Factor

Example Calculation: Peak

Corrected Level: $50.95 + 0.31 = 51.26$ dB μ V/m

Margin: 74 dB μ V/m – 51.26 dB μ V/m = 22.7 dB

Example Calculation: Average

Corrected Level: $39.67 + 0.31 = 39.98$ dB μ V/m

Margin: 54 dB μ V/m – 39.98 dB μ V/m = 14.0 dB

8 CONCLUSION

In the opinion of ACS, Inc., the models MS2G and MS2GC manufactured by Juniper Systems, Inc. meet the requirements of FCC Part 15 subpart C and Industry Canada's Radio Standards Specification RSS-247 for the test procedures documented in the test report.

END REPORT