

## **Certification Test Report**

**FCC ID: VSFMS2  
IC: 7980A-MS2**

**FCC Rule Part: 15.247  
IC Radio Standards Specification: RSS-247**

**ACS Report Number: 15-2133.W06.2A**

Applicant: Juniper Systems, Inc.

Model(s): MS2G and MS2GC

Test Begin Date: **December 10, 2015**  
Test End Date: **March 4, 2016**

Report Issue Date: March 4, 2016



FOR THE SCOPE OF ACCREDITATION UNDER CERTIFICATE NUMBER AT-1533

This report must not be used by the client to claim product certification, approval, or endorsement by ANAB, ANSI, or any agency of the Federal Government.

**Reviewed by:**



A handwritten signature in black ink, appearing to read 'Thierry Jean-Charles'.

**Thierry Jean-Charles  
EMC Engineer  
Advanced Compliance Solutions, Inc.**

This test report shall not be reproduced except in full. This report may be reproduced in part with prior written consent of ACS, Inc. The results contained in this report are representative of the sample(s) submitted for evaluation.

**This report contains 33 pages**

## TABLE OF CONTENTS

<b>1</b>	<b>GENERAL .....</b>	<b>3</b>
1.1	Purpose .....	3
1.2	Applicant Information .....	3
1.3	Product Description.....	3
1.4	Test Methodology and Considerations .....	4
<b>2</b>	<b>TEST FACILITIES .....</b>	<b>5</b>
2.1	Location.....	5
2.2	Laboratory Accreditations/Recognitions/Certifications .....	5
2.3	Radiated & Conducted Emissions Test Site Description .....	6
<b>3</b>	<b>APPLICABLE STANDARD REFERENCES.....</b>	<b>8</b>
<b>4</b>	<b>LIST OF TEST EQUIPMENT.....</b>	<b>9</b>
<b>5</b>	<b>SUPPORT EQUIPMENT .....</b>	<b>10</b>
<b>6</b>	<b>EQUIPMENT UNDER TEST SETUP BLOCK DIAGRAM .....</b>	<b>10</b>
<b>7</b>	<b>SUMMARY OF TESTS.....</b>	<b>11</b>
7.1	Antenna Requirement – FCC: Section 15.203 .....	11
7.2	6 dB Bandwidth - FCC: Section 15.247(a)(2) IC: RSS-247 5.5(1); 99% Bandwidth IC: RSS-GEN 6.6 .....	11
7.3	Peak Output Power - FCC Section 15.247(b)(3) IC: RSS-247 5.4(4) .....	15
7.4	Band-Edge Compliance and Spurious Emissions-FCC 15.247(d) IC: RSS-247 5.5.....	17
7.5	Power Spectral Density - FCC Section 15.247(e) IC: RSS-247 5.2(2) .....	28
7.6	Power Line Conducted Emissions – FCC: Section 15.207 IC: RSS-Gen 8.8.....	30
<b>8</b>	<b>CONCLUSION.....</b>	<b>33</b>

**1 GENERAL****1.1 Purpose**

The purpose of this report is to demonstrate compliance with Part 15 Subpart C of the FCC's Code of Federal Regulations and Industry Canada's Radio Standards Specification RSS-247.

**1.2 Applicant Information**

Juniper Systems, Inc.  
1132 West 1700 North  
Logan, UT 84321

**1.3 Product Description**

The MS2G and MS2GC consist of ultra-rugged tablet computers, featuring a 7-inch touchscreen display and running Microsoft Windows 8.1/10 Professional, Bluetooth 4.0 and WLAN 802.11a/b/g/n. The two models are identical except that the MS2GC model includes a pre-approved cellular module (FCC ID: VSF25271/ IC:7980A-25271). This test report documents the compliance of Bluetooth Low Energy mode of operation.

Technical Details

Mode of Operation: Bluetooth Low Energy (BLE)  
Frequency Range: 2402 MHz - 2480 MHz  
Number of Channels: 40  
Channel Separation: 2 MHz  
Modulations: GFSK  
Antenna Type/Gain: PIFA, 2.5 dBi  
Input Power: 12VDC Power Supply

Model Number: MS2G and MS2GC

Test Sample Serial Number(s): MS2P58 (RF Conducted Emissions), MS2P34 (Radiated and Power Line Conducted Emissions).

Test Sample Condition: The equipment was provided in good condition without any physical damage.

#### **1.4 Test Methodology and Considerations**

The EUT was evaluated for radiated, power line and RF conducted emissions.

For radiated emissions, preliminary evaluation was performed for the EUT standalone as well as for the EUT powered through a wall adapter. The investigation was performed in three orthogonal orientations. Additional measurements were performed on two MS2 models configurations consisting of the MS2G and the MS2GC. No significant emission variation was observed between the models and the final measurements were performed on MS2G model.

The RF conducted emissions measurements were performed for the EUT modified with a temporary RF connector for direct coupling to a spectrum analyzer.

The EUT was also evaluated for intermodulation product for the MS2GC model which includes the EM7355 cellular module (FCC ID: VSF25271/ IC:7980A-25271). The BLE transceiver and Cell radios were set to transmit simultaneously and the intermodulation products were investigated and compared to the FCC Section 15.209 and the RSS-GEN general limits. All intermodulation products were found to be compliant.

The EUT was also evaluated for unintentional emissions. The results are documented separately in a Declaration of Conformity/Verification test report.

## **2 TEST FACILITIES**

### **2.1 Location**

The radiated and conducted emissions test sites are located at the following address:

Advanced Compliance Solutions, Inc.  
3998 FAU Blvd, Suite 310  
Boca Raton, Florida 33431  
Phone: (561) 961-5585  
Fax: (561) 961-5587  
[www.acstestlab.com](http://www.acstestlab.com)

FCC Test Firm Registration #: 475089  
Industry Canada Lab Code: 4175C

### **2.2 Laboratory Accreditations/Recognitions/Certifications**

ACS is accredited to ISO/IEC 17025 by ANSI-ASQ National Accreditation Board under their ANAB program and has been issued certificate number AT-1533 in recognition of this accreditation. Unless otherwise specified, all test methods described within this report are covered under the ISO/IEC 17025 scope of accreditation.

**2.3 Radiated & Conducted Emissions Test Site Description**

**2.3.1 Semi-Anechoic Chamber Test Site**

The EMC radiated test facility consists of an RF-shielded enclosure. The interior dimensions of the indoor semi-anechoic chamber are approximately 48 feet (14.6 m) long by 36 feet (10.8 m) wide by 24 feet (7.3 m) high and consist of rigid, 1/8 inch (0.32 cm) steel-clad, wood core modular panels with steel framing. In the shielded enclosure, the faces of the panels are galvanized and the chamber is self-supporting. 8-foot RF absorbing cones are installed on 4 walls and the ceiling. The steel-clad ground plane is covered with vinyl flooring.

The turntable is driven by pneumatic motor, which is capable of supporting a 2000 lb. load. The turntable is flush with the chamber floor which it is connected to, around its circumference, with a continuous metallic loaded spring. An EMCO Model 1050 Multi-device controller controls the turntable position.

A pneumatic motor is used to control antenna polarizations and height relative to the ground. The height information is displayed on the control unit EMCO Model 1050.

The control room is an RF shielded enclosure attached to the semi-anechoic chamber with two bulkhead panels for connecting RF, and control cables. The dimension of the room is 7.3 m x 4.9 m x 3 m high and the entrance doors of both control and conducted rooms are 3 feet (0.91 m) by 7 feet (2.13 m).

A diagram of the Semi-Anechoic Chamber Test Site is shown in Figure 2.3.1-1 below:

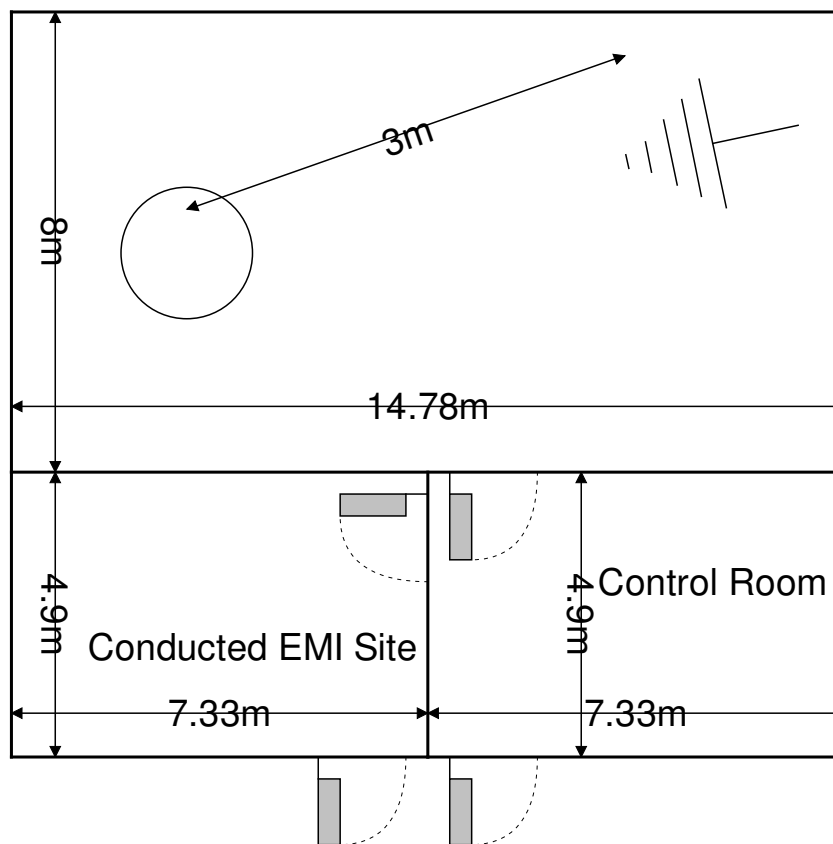
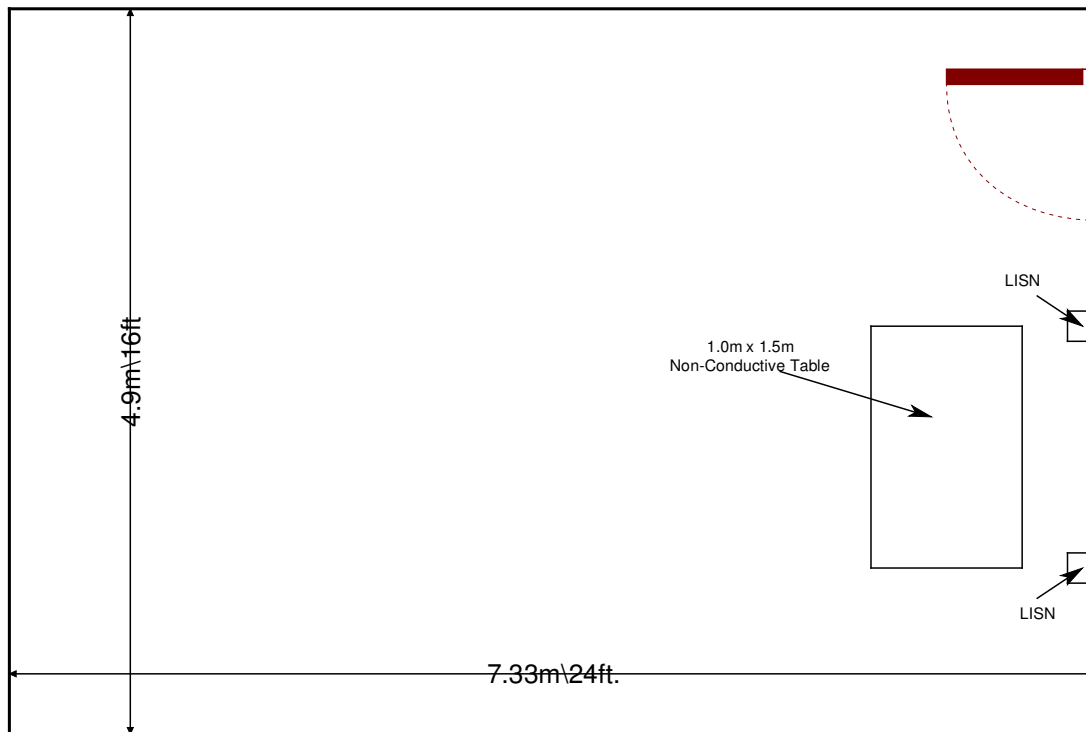

**Figure 2.3.1-1: Semi-Anechoic Chamber Test Site**

**2.3.2 Conducted Emissions Test Site Description**

The dimensions of the shielded conducted room are 7.3 x 4.9 x 3 m<sup>3</sup>. The power line conducted emission site includes two LISNs: a Solar Model 8028-50 50 Ω/50 μH and an EMCO Model 3825/2R, which are installed as shown in the figure below. For evaluations requiring 230 V, 50 Hz AC input, a Polarad LISN (S/N 879341/048) is used in conjunction with a California Instruments signal generator Model 2001RP-OP1.

A diagram of the room is shown below in figure 2.3.2-1:



**Figure 2.3.2-1: AC Mains Conducted EMI Site**

**3 APPLICABLE STANDARD REFERENCES**

The following standards were used:

- ❖ ANSI C63.4-2014: Method of Measurements of Radio-Noise Emissions from Low-Voltage Electrical and Electronic Equipment in the 9 kHz to 40 GHz.
- ❖ ANSI C63.10-2013: American National Standard of Procedures for Compliance Testing of Unlicensed Wireless Devices
- ❖ US Code of Federal Regulations (CFR): Title 47, Part 2, Subpart J: Equipment Authorization Procedures, 2016.
- ❖ US Code of Federal Regulations (CFR): Title 47, Part 15, Subpart C: Radio Frequency Devices, Intentional Radiators, 2016
- ❖ Industry Canada Radio Standards Specification: RSS-247 — Digital Transmission Systems (DTSs), Frequency Hopping Systems (FHSs) and Licence-Exempt Local Area Network (LE-LAN) Devices, Issue 1, May 2015.
- ❖ Industry Canada Radio Standards Specification: RSS-GEN – General Requirements for Compliance of Radio Apparatus, Issue 4, November 2014.



#### 4 LIST OF TEST EQUIPMENT

The calibration interval of test equipment is annually or the manufacturer's recommendations. Where the calibration interval deviates from the annual cycle based on the instrument manufacturer's recommendations, it shall be stated below.

Table 4-1: Test Equipment

Table 4-1: Test Equipment List

AssetID	Manufacturer	Model #	Equipment Type	Serial #	Last Calibration Date	Calibration Due Date
22	Agilent	8449B	Amplifiers	3008A00526	5/18/2015	5/18/2016
283	Rohde & Schwarz	FSP40	Spectrum Analyzers	1000033	7/1/2015	7/1/2016
479	Electro-Metrics	ALP-70	Antennas	158	12/2/2013	12/2/2015
479	Electro-Metrics	ALP-70	Antennas	158	12/3/2015	12/3/2017
523	Agilent	E7405	Spectrum Analyzers	MY45103293	12/26/2014	12/26/2016
653	Suhner	SF-102A	Cables	0944/2A	4/13/2015	4/13/2016
2002	EMCO	3108	Antennas	2147	11/19/2015	11/19/2017
2004	EMCO	3146	Antennas	1385	11/19/2015	11/19/2017
2006	EMCO	3115	Antennas	2573	4/14/2015	4/14/2017
2008	COM-Power	AH-826	Antennas	81009	NCR	NCR
2011	Hewlett-Packard	HP 8447D	Amplifiers	2443A03952	11/18/2015	11/18/2016
2022	EMCO	LISN3825/2R	LISN	1095	9/14/2015	9/14/2017
2045	ACS Boca	Conducted Cable Set	Cable Set	2045	11/11/2015	11/11/2016
2070	Mini Circuits	VHF-8400+	Filter	2070	11/17/2015	11/17/2016
2072	Mini Circuits	VHF-3100+	Filter	30737	11/17/2015	11/17/2016
2082	Teledyne Storm Products	90-010-048	Cables	2082	4/22/2015	4/22/2016
2086	Merrimac	FAN-6-10K	Attenuators	23148-83-1	11/16/2015	11/16/2016
2089	Agilent Technologies, Inc.	83017A	Amplifiers	3123A00214	12/9/2015	12/9/2016
2095	ETS Lindgren	TILE4! - Version 4.2.A	Software	85242	NCR	NCR
2111	Aeroflex Inmet	40AH2W-20	Attenuator	2111	7/22/2015	7/22/2016
2121	ACS Boca	Radiated Cable Set	Cable Set	2121	8/22/2015	8/22/2016
3004	Teseq	CFL 9206A	Attenuators	34720	10/7/2015	10/7/2016
RE619	Rhode & Schwarz	ESU26	Spectrum Analyzers	1302.6005K26 Ser. 100190	11/5/2014	11/5/2016

**Notes:**

- **NCR=No Calibration Required**
- **The calibration information cycle for asset 479 is provided to cover the entire test period. The asset was only used during the active period of the calibration cycle.**

5 SUPPORT EQUIPMENT

Table 5-1: EUT and Support Equipment

Item #	Type Device	Manufacturer	Model/Part #	Serial #
1	EUT	Juniper Systems, Inc.	MS2	MS2P34
2	12 VDC Power Supply	PhiHong	PSAA20R-120	P51904229A1
3	Earbuds	Maxell	N/A	N/A
4	Mouse	Insignia	NS-PNC5001	15G03A003432

Table 5-2: Cable Description (Radiated Emissions)

Cable #	Cable Type	Length	Shield	Termination
A	Power	1.5 m	No	Power Supply To EUT
B	Audio	0.92 m	No	Earbuds to EUT
C	USB	1.55 m	No </td <td>Mouse to EUT</td>	Mouse to EUT
D	Extension Power Cord	2.7 m	No	Power Supply to AC Mains

6 EQUIPMENT UNDER TEST SETUP BLOCK DIAGRAM

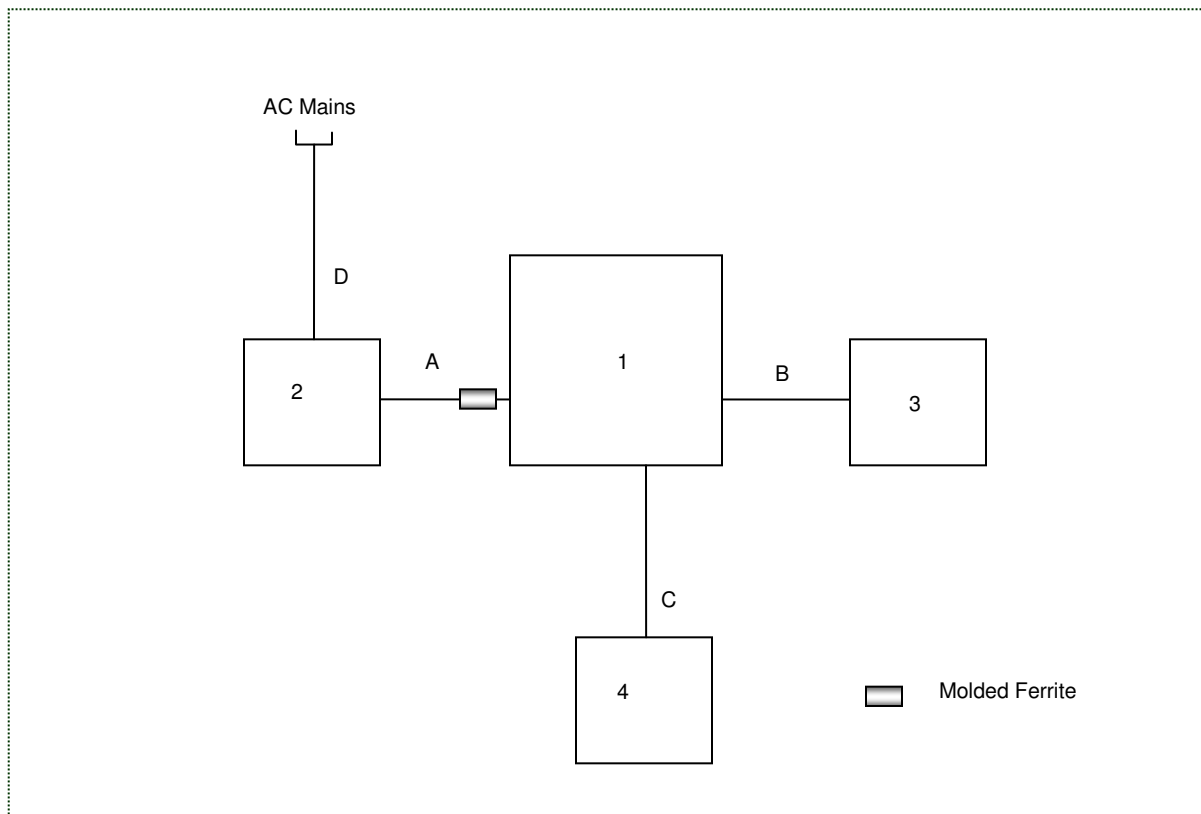

Figure 6-1: EUT Test Setup

## 7 SUMMARY OF TESTS

Along with the tabular data shown below, plots were taken of all signals deemed important enough to document.

### 7.1 Antenna Requirement – FCC: Section 15.203

The MS2 uses a 2.5 dBi Internal PIFA that is directly soldered to the PCB. The antenna is neither removable nor accessible to the end-user. Thus, the equipment meets the requirements of FCC Section 15.203.

### 7.2 6 dB Bandwidth - FCC: Section 15.247(a)(2) IC: RSS-247 5.5(1); 99% Bandwidth IC: RSS-GEN 6.6

#### 7.2.1 Measurement Procedure

The 6dB bandwidth was measured in accordance with ANSI C63.10:2013 Section 11.8 DTS Bandwidth Option 2. The RBW of the spectrum analyzer was set to 100 kHz and VBW 300 kHz. Span was set large enough to capture the emissions and  $\gg$  RBW.

The 99% occupied bandwidth was measured with the spectrum analyzer span set to fully display the emission. The RBW was set to 1% to 5% of the approximated bandwidth. The occupied 99% bandwidth was measured by using 99% bandwidth equipment function of the spectrum analyzer.

#### 7.2.2 Measurement Results

Results are shown below.

**Table 7.2.2-1: 6dB / 99% Bandwidth**

Frequency [MHz]	6dB Bandwidth [kHz]	99% Bandwidth (kHz)
2402	712	1056
2440	704	1048
2480	712	1056

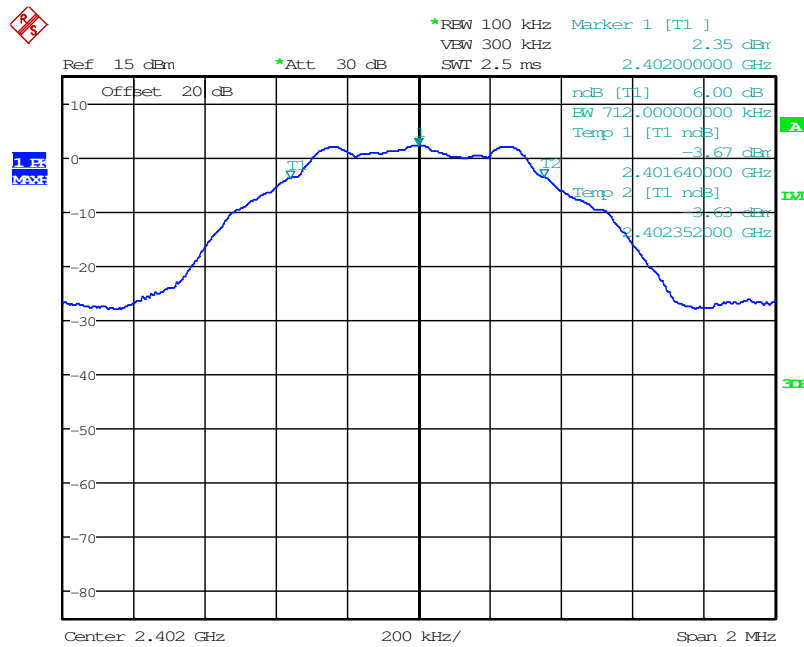

Date: 19.DEC.2015 12:05:01

Figure 7.2.2-1: 6dB BW - Low Channel

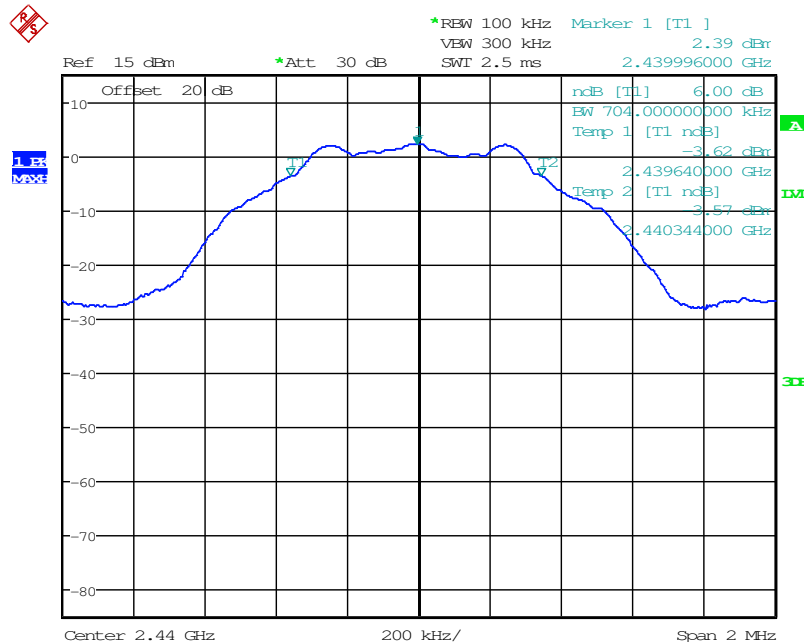

Date: 19.DEC.2015 12:03:07

Figure 7.2.2-2: 6dB BW - Middle Channel

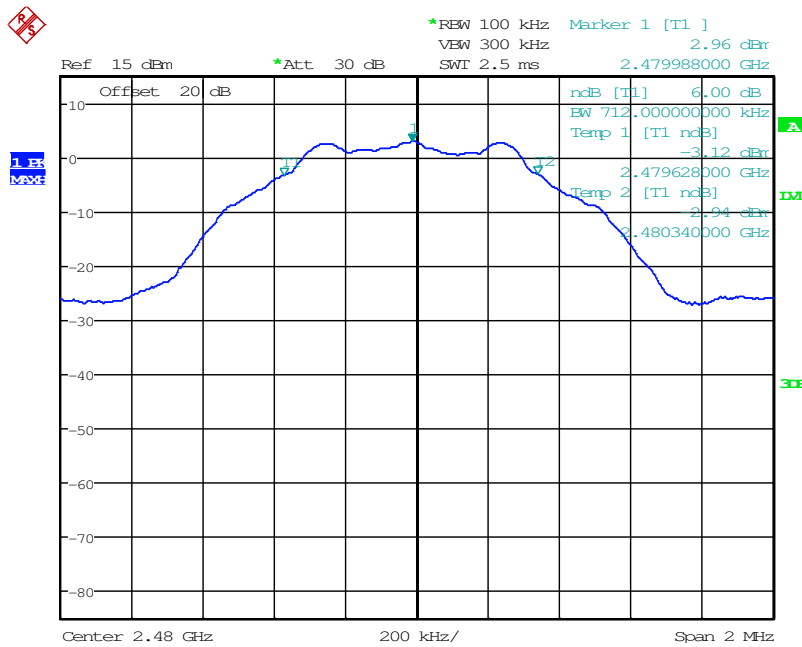

Date: 19.DEC.2015 12:01:46

Figure 7.2.2-3: 6dB BW - High Channel

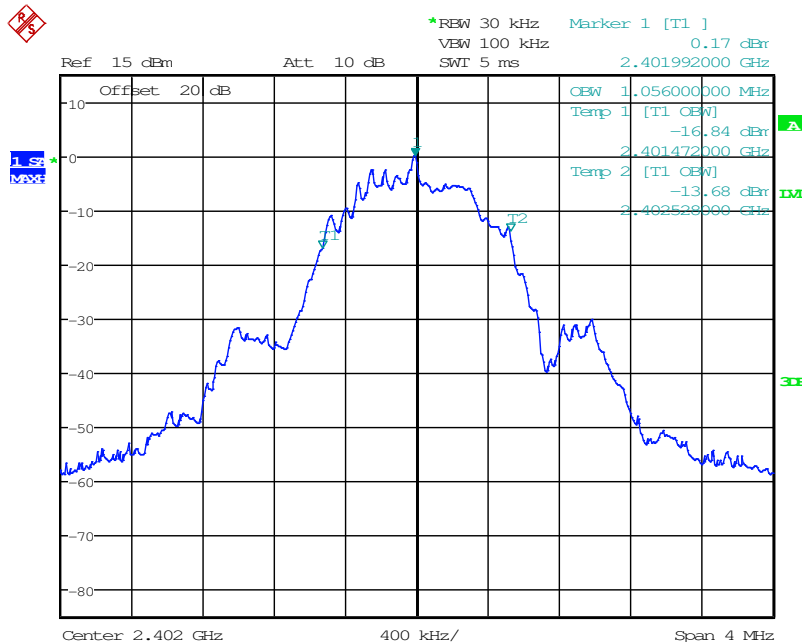

Date: 19.DEC.2015 12:25:34

Figure 7.2.2-4: 99% OBW - Low Channel

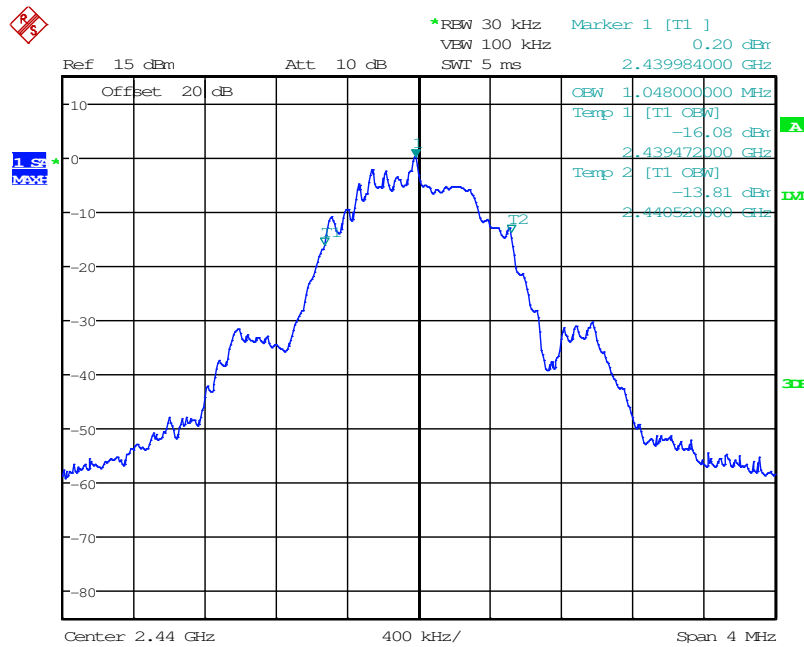

Date: 19.DEC.2015 12:28:18

Figure 7.2.2-5: 99% OBW - Middle Channel

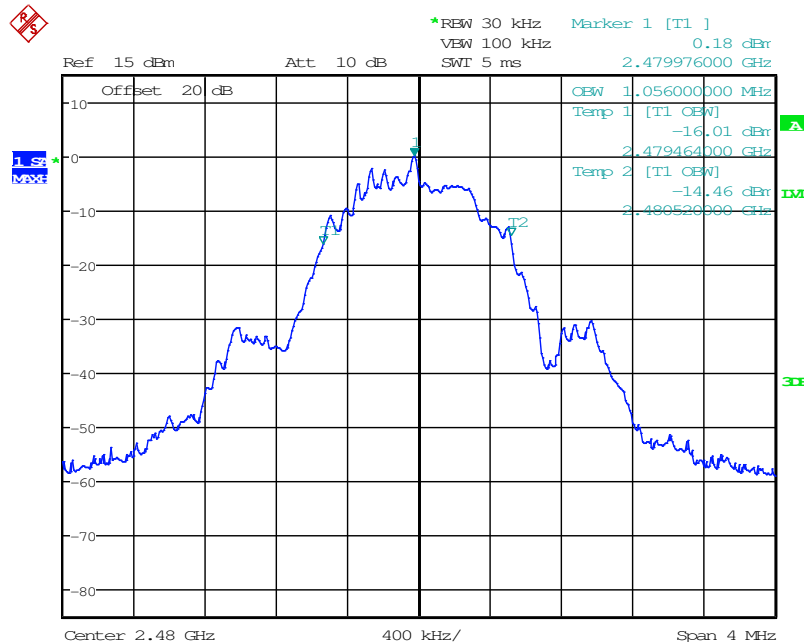

Date: 19.DEC.2015 12:30:19

Figure 7.2.2-6: 99% OBW - High Channel

7.3 Peak Output Power - FCC Section 15.247(b)(3) IC: RSS-247 5.4(4)

7.3.1 Measurement Procedure (Conducted Method)

The fundamental emission output power was measured in accordance with ANSI C63.10:2013 Section 11.9.1.1 RBW  $\geq$  DTS bandwidth. The RF output of the equipment under test was directly connected to the input of the spectrum analyzer through suitable attenuation.

7.3.2 Measurement Results

Results are shown below.

Table 7.3.2-1: RF Output Power

Frequency [MHz]	Level [dBm]
2402	3.49
2440	3.55
2480	3.55

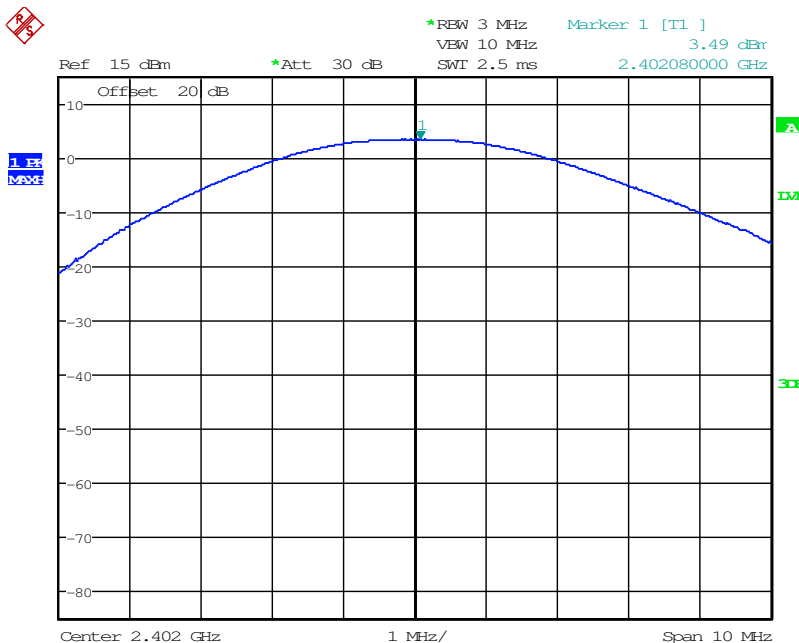

Date: 19.DEC.2015 12:07:51

Figure 7.3.2-1: RF Output Power - Low Channel

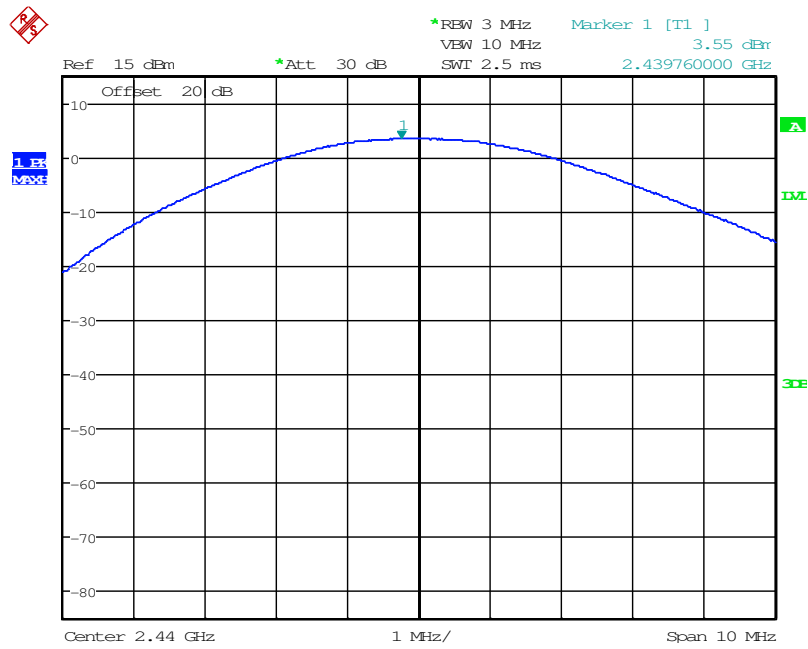

Date: 19.DEC.2015 12:09:51

Figure 7.3.2-2: RF Output Power - Middle Channel

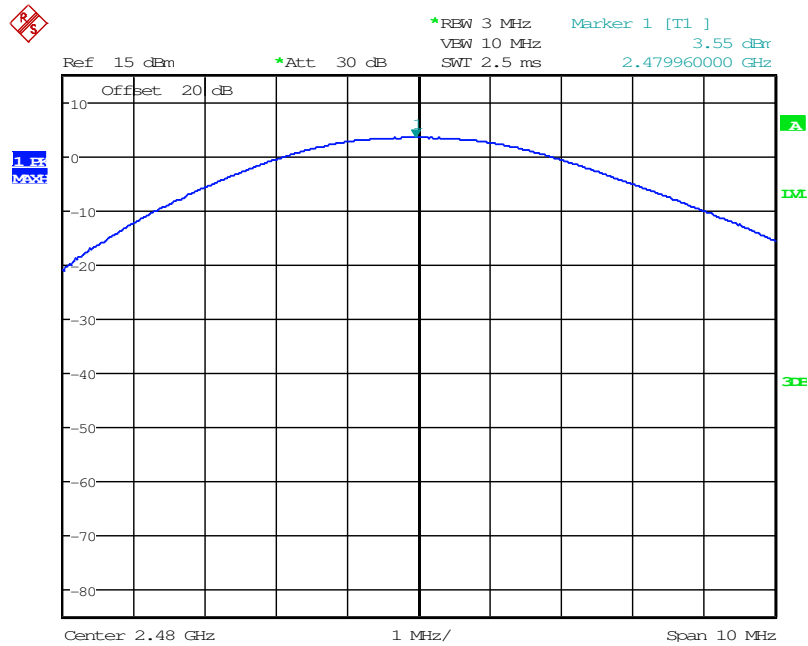

Date: 19.DEC.2015 12:12:34

Figure 7.3.2-3: RF Output Power - High Channel



### 7.4 Band-Edge Compliance and Spurious Emissions-FCC 15.247(d) IC: RSS-247 5.5

#### 7.4.1 Band-Edge Compliance of RF Conducted Emissions

##### 7.4.1.1 Measurement Procedure

The RF output port of the EUT was directly connected to the input of the spectrum analyzer via suitable attenuation. The EUT was investigated at the lowest and highest channel available to determine band-edge compliance. For each measurement the spectrum analyzer's RBW was set to 100 kHz, and the VBW was set to 300 kHz.

##### 7.4.1.2 Measurement Results

Results are shown below.

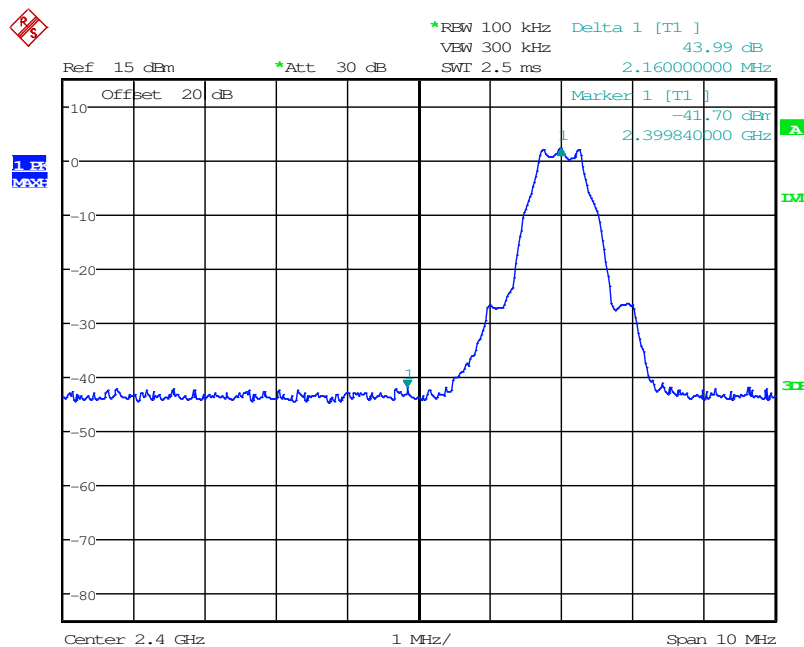

Date: 18.DEC.2015 20:11:50

Figure 7.4.1.2-1: Lower Band-edge

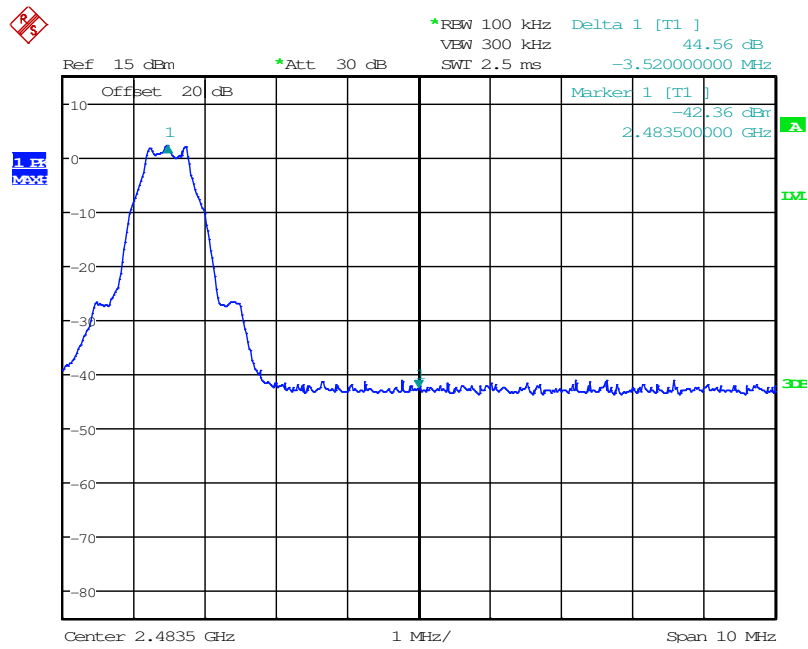

Date: 18.DEC.2015 20:27:04

Figure 7.4.1.2-2: Upper Band-edge

### 7.4.2 RF Conducted Spurious Emissions

#### 7.4.2.1 Measurement Procedure

The RF Conducted Spurious Emissions were measured in accordance with ANSI C63.10:2013 Section 11.11 Emissions in non-restricted frequency bands. The RF output port of the equipment under test was directly connected to the input of the spectrum analyzer. The EUT was investigated for conducted spurious emissions from 30MHz to 26 GHz, 10 times the highest fundamental frequency. Measurements were made at the low, center and high channels of the EUT. For each measurement, the spectrum analyzer's RBW was set to 100 kHz and the VBW was set to 300 kHz. The peak Max Hold function of the analyzer was utilized. The reference level was determined by measuring the Peak PSD level in any 100 kHz bandwidth within the DTS channel bandwidth.

#### 7.4.2.2 Measurement Results

Results are shown below.

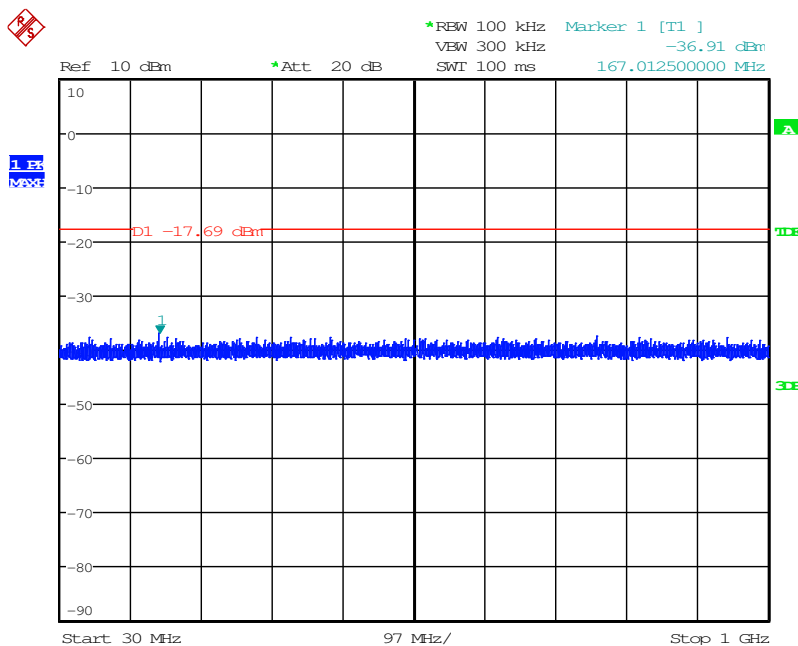

Date: 19.DEC.2015 15:46:49

Figure 7.4.2.2-1: 30 MHz – 1 GHz – Low Channel

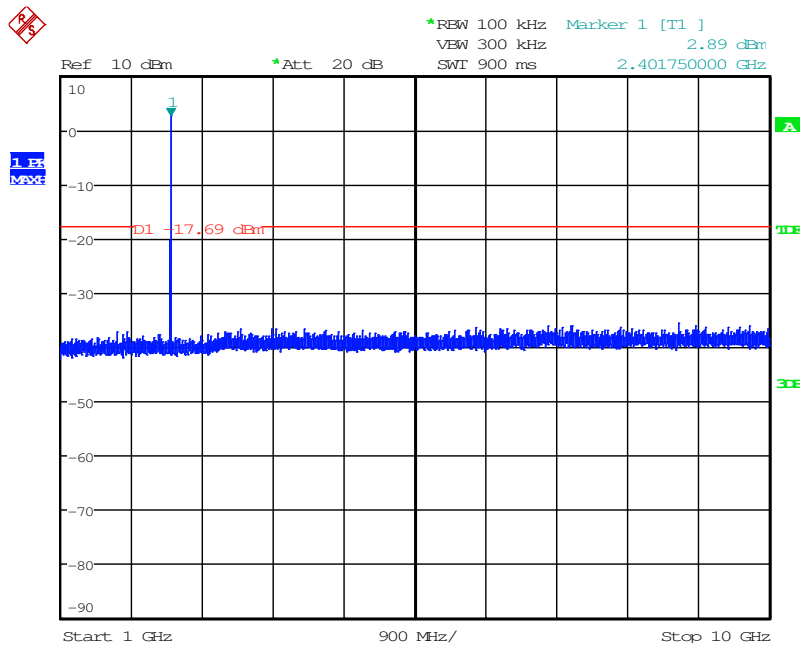

Date: 19.DEC.2015 15:49:42

Figure 7.4.2.2-2: 1 GHz –10 GHz – Low Channel

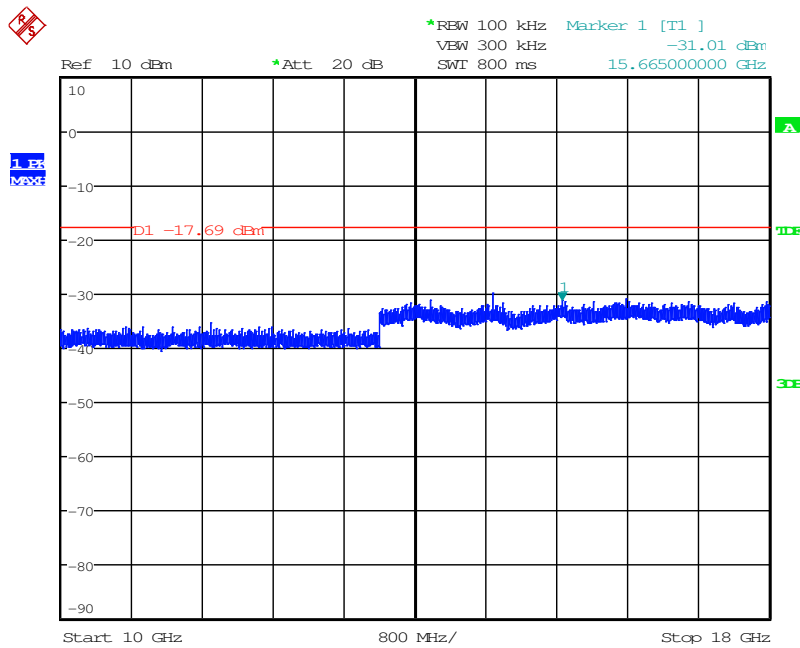

Date: 19.DEC.2015 15:51:44

Figure 7.4.2.2-3: 10 GHz –18 GHz – Low Channel



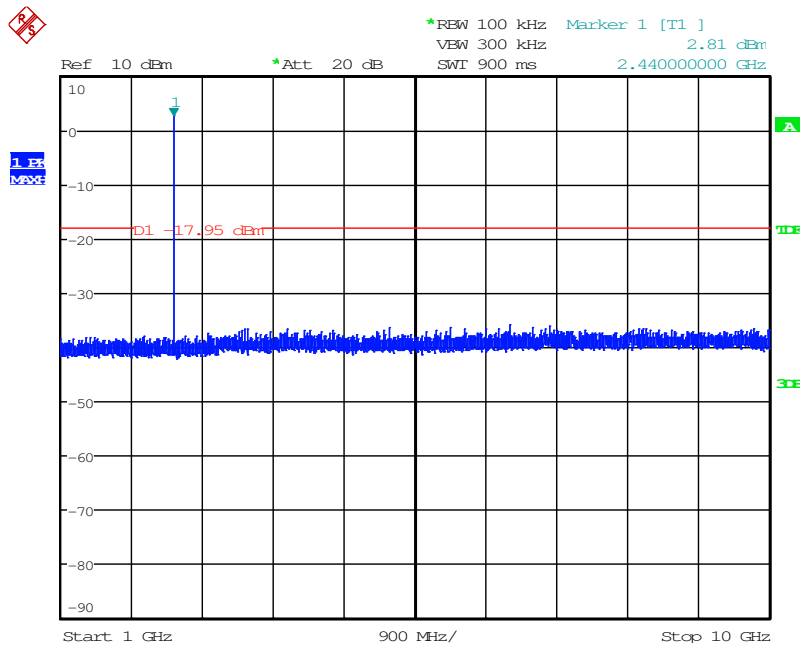

Date: 19.DEC.2015 16:09:47

Figure 7.4.2.2-6: 1 GHz –10 GHz – Middle Channel

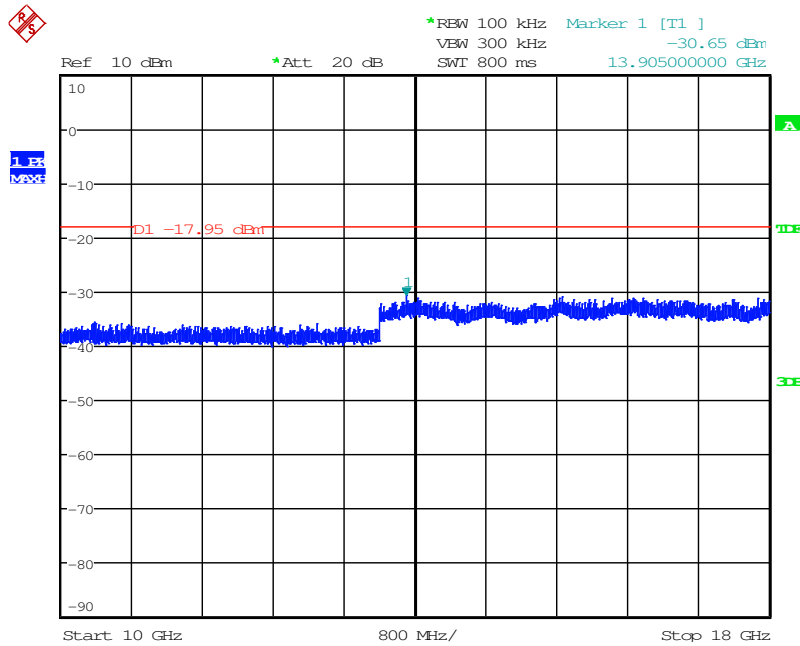

Date: 19.DEC.2015 16:07:50

Figure 7.4.2.2-7: 10 GHz –18 GHz – Middle Channel

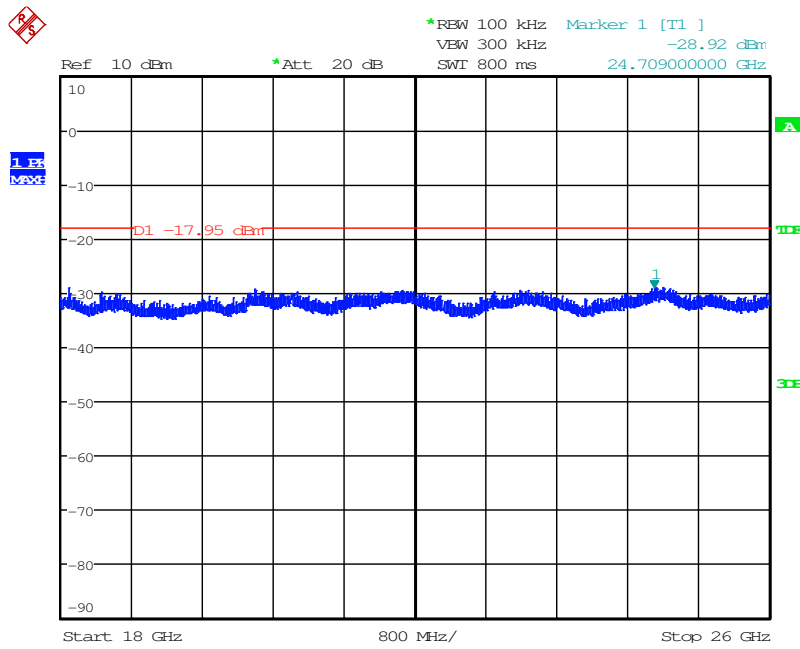

Date: 19.DEC.2015 16:04:41

Figure 7.4.2.2-8: 18 GHz – 26 GHz – Middle Channel

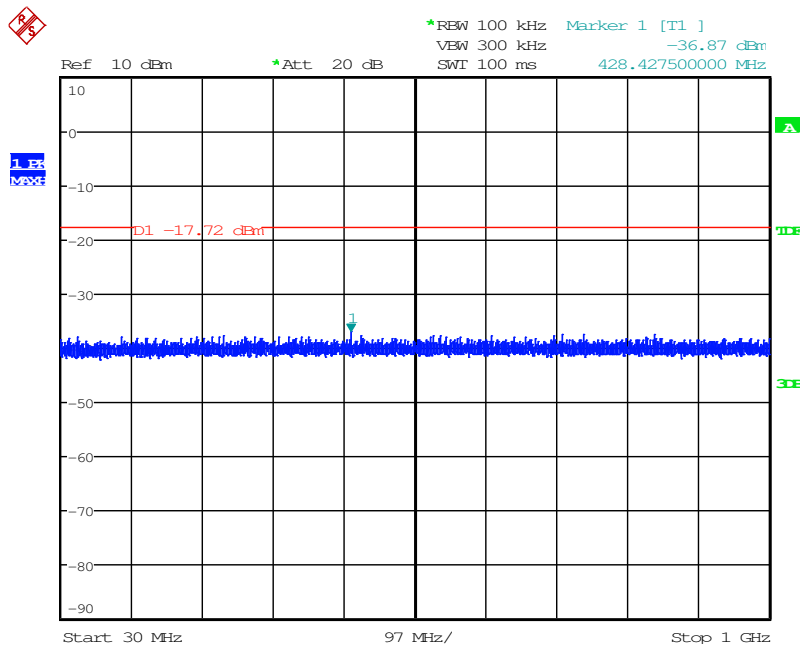

Date: 19.DEC.2015 16:17:47

Figure 7.4.2.2-9: 30 MHz – 1 GHz – High Channel

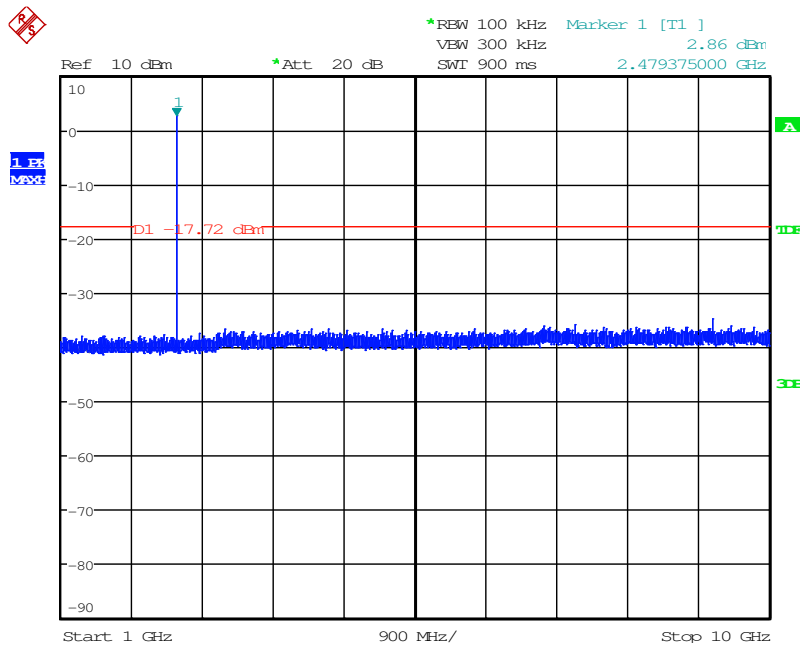

Date: 19.DEC.2015 16:22:14

Figure 7.4.2.2-10: 1 GHz –10 GHz –High Channel

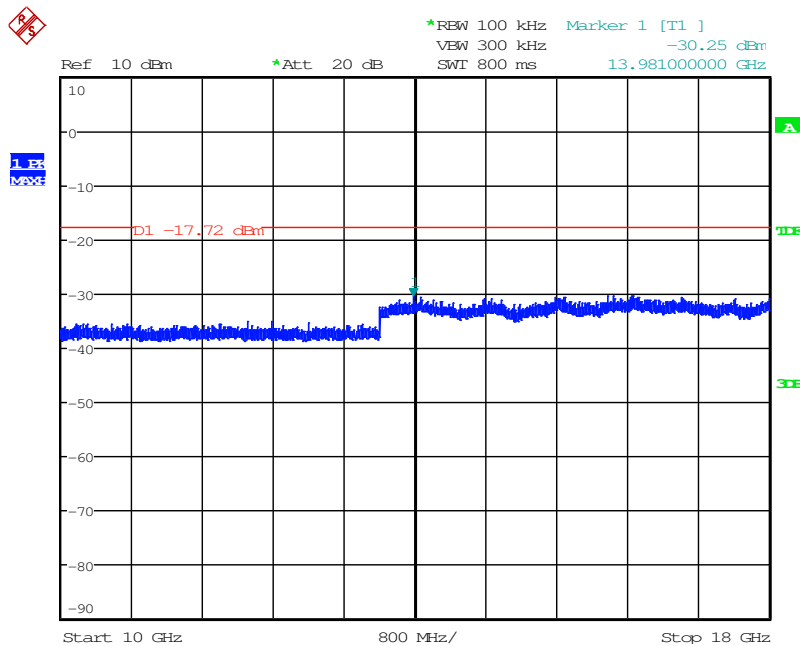

Date: 19.DEC.2015 16:40:17

Figure 7.4.2.2-11: 10 GHz – 18 GHz –High Channel



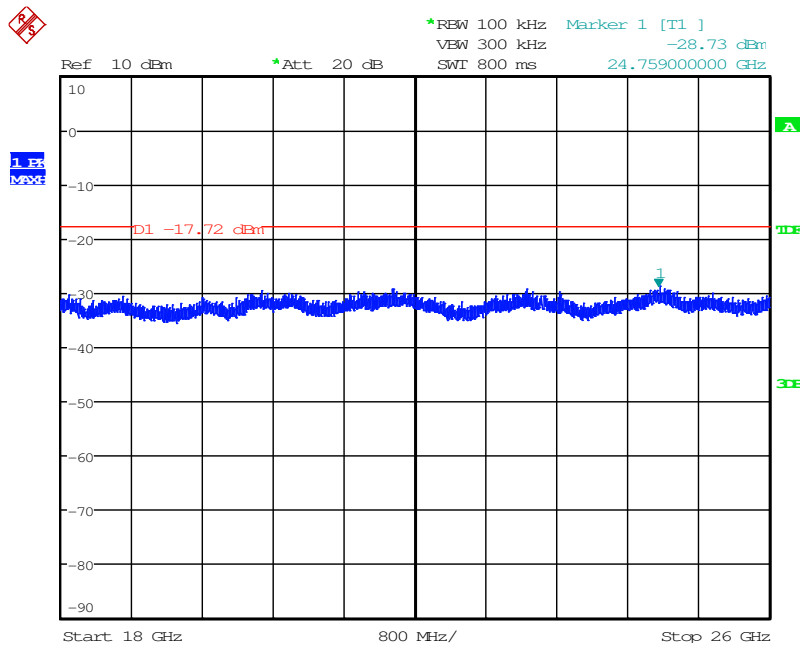

Date: 19.DEC.2015 16:45:36

Figure 7.4.2.2-12: 18 GHz – 26 GHz –High Channel

### 7.4.3 Radiated Spurious Emissions into Restricted Frequency Bands - FCC 15.205, 15.209; IC: RSS-Gen 8.9, 8.10

#### 7.4.3.1 Measurement Procedure

Radiated emissions tests were made over the frequency range of 9 kHz to 26 GHz, 10 times the highest fundamental frequency. Each emission found to be in a restricted band as defined by section 15.205, including any emission at the operational band-edge, was compared to the radiated emission limits as defined in section 15.209.

For measurements below 30 MHz, the receive antenna height was set to 1m and the EUT was rotated through 360 degrees. The resolution bandwidth was set to 200 Hz below 150 kHz and to 9 kHz above 150 kHz.

The EUT was rotated through 360° and the receive antenna height was varied from 1m to 4m so that the maximum radiated emissions level would be detected. For frequencies below 1000MHz, quasi-peak measurements were made using a resolution bandwidth RBW of 120 kHz and a video bandwidth VBW of 300 kHz. For frequencies above 1000 MHz, peak measurements are made with RBW of 1 MHz and VBW of 3 MHz. Average measurements are performed in the linear scale using VBW of 30 Hz over a 5 second sweep.

#### 7.4.3.2 Measurement Results

Radiated band-edge and spurious emissions found in the restricted frequency bands of 9 kHz to 26 GHz are reported in the tables below.

**Table 7.4.3.2-1: Radiated Spurious Emissions Tabulated Data**

Frequency (MHz)	Level (dBuV)		Antenna Polarity (H/V)	Correction Factors (dB)	Corrected Level (dBuV/m)		Limit (dBuV/m)		Margin (dB)	
	pk	Qpk/Avg			pk	Qpk/Avg	pk	Qpk/Avg	pk	Qpk/Avg
<b>Low Channel = 2402 MHz</b>										
4804	36.95	27.51	H	8.53	45.48	36.04	74.0	54.0	28.5	18.0
4804	38.33	27.47	V	8.53	46.86	36.00	74.0	54.0	27.1	18.0
<b>Middle Channel = 2440 MHz</b>										
4880	36.67	26.79	H	8.80	45.47	35.59	74.0	54.0	28.5	18.4
4880	38.21	27.18	V	8.80	47.01	35.98	74.0	54.0	27.0	18.0
<b>High Channel = 2480 MHz</b>										
2483.5	54.13	47.33	H	0.79	54.92	48.12	74.0	54.0	19.1	5.9
2483.5	53.30	45.87	V	0.79	54.09	46.66	74.0	54.0	19.9	7.3
4960	37.07	26.80	H	9.09	46.16	35.89	74.0	54.0	27.8	18.1
4960	37.53	27.01	V	9.09	46.62	36.10	74.0	54.0	27.4	17.9

**Note: All emissions above 4.96 GHz were attenuated below the limits and the noise floor of the measurement equipment.**

**7.4.3.3 Sample Calculation:**

$$R_C = R_U + CF_T$$

Where:

$CF_T$	=	Total Correction Factor (AF+CA+AG)-DC (Average Measurements Only)
$R_U$	=	Uncorrected Reading
$R_C$	=	Corrected Level
AF	=	Antenna Factor
CA	=	Cable Attenuation
AG	=	Amplifier Gain
DC	=	Duty Cycle Correction Factor

**Example Calculation: Peak**Corrected Level:  $36.95 + 8.53 = 45.48$  dB $\mu$ V/mMargin:  $74$  dB $\mu$ V/m  $- 45.48$  dB $\mu$ V/m =  $28.5$  dB**Example Calculation: Average**Corrected Level:  $27.51 + 8.53 = 36.04$  dB $\mu$ V/mMargin:  $54$  dB $\mu$ V/m  $- 36.04$  dB $\mu$ V/m =  $18.0$ dB

7.5 Power Spectral Density - FCC Section 15.247(e) IC: RSS-247 5.2(2)

7.5.1 PSD Measurement Procedure (Conducted Method)

The power spectral density was measured in accordance with ANSI C63.10:2013 Section 10.2 Method PKPSD (peak PSD). The RF output port of the EUT was directly connected to the input of the spectrum analyzer. Offset values were input for cable and external attenuation. The spectrum analyzer RBW was set to 3 kHz and VBW 10 kHz. Span was adjusted to 1.5 times the 6 dB bandwidth and the sweep time was set to auto.

7.5.2 Measurement Results

Results are shown below.

Table 7.5.2-1: Power Spectral Density

Frequency (MHz)	PSD (dBm)	Limit (dBm)	Margin (dB)
2402	-11.29	8.0	19.29
2440	-11.48	8.0	19.48
2480	-11.34	8.0	19.34

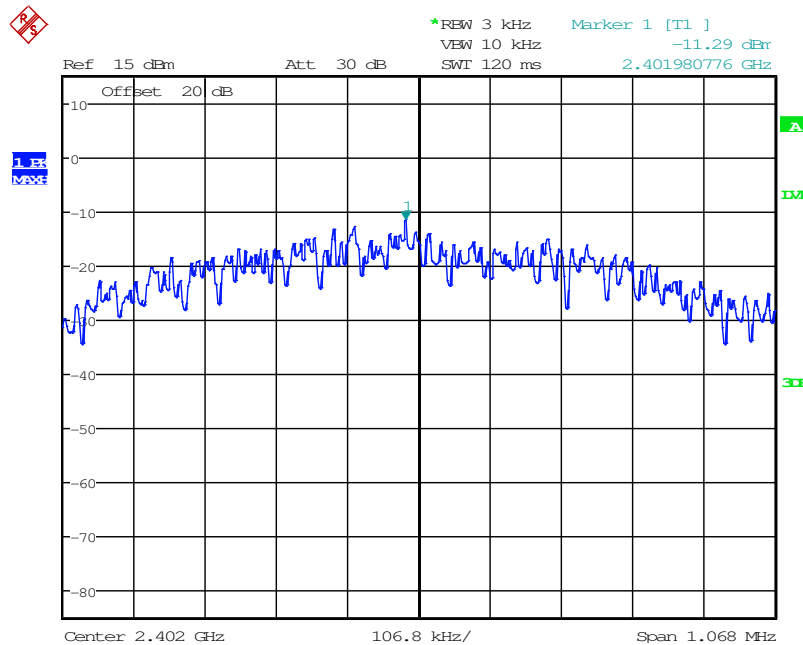

Date: 19.DEC.2015 12:41:50

Figure 7.5.2-1: Power Spectral Density - Low Channel

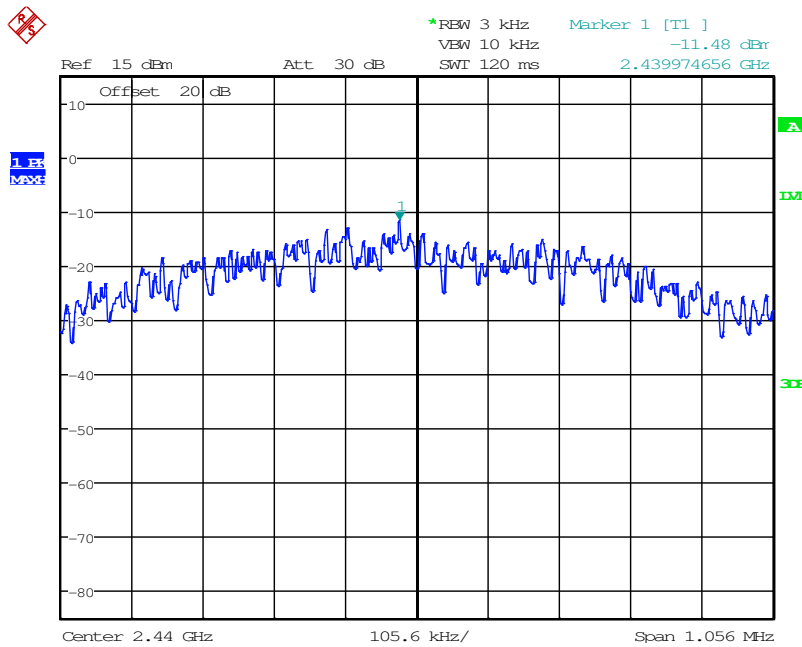

Date: 19.DEC.2015 13:04:25

Figure 7.5.2-2: Power Spectral Density - Middle Channel

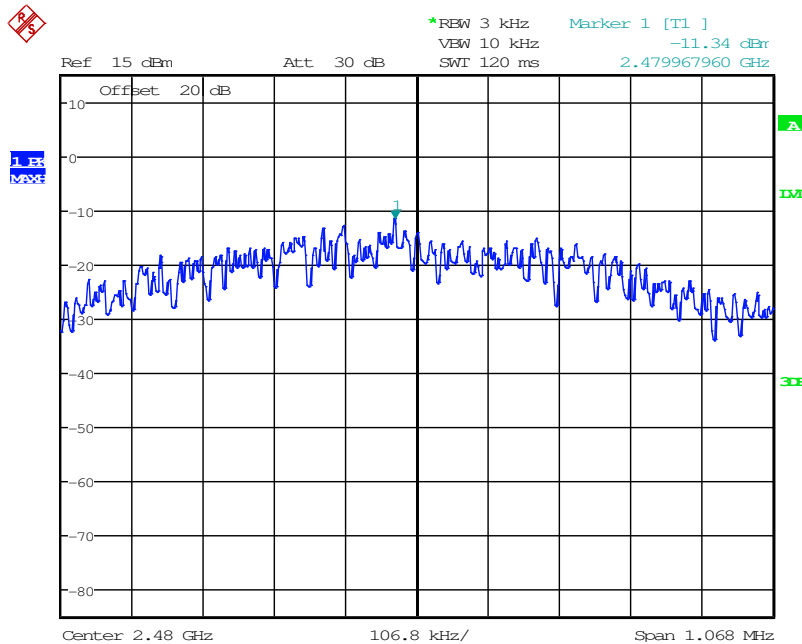

Date: 19.DEC.2015 12:38:33

Figure 7.5.2-3: Power Spectral Density – High Channel

7.6 Power Line Conducted Emissions – FCC: Section 15.207 IC: RSS-Gen 8.8

7.6.1 Measurement Procedure

ANSI C63.4 sections 6 and 7 were the guiding documents for this evaluation. Conducted emissions were performed from 150 kHz to 30 MHz with the spectrum analyzer’s resolution bandwidth set to 9 kHz and the video bandwidth set to 30 kHz. The calculation for the conducted emissions is as follows:

$$\text{Corrected Reading} = \text{Analyzer Reading} + \text{LISN Loss} + \text{Cable Loss}$$

$$\text{Margin} = \text{Applicable Limit} - \text{Corrected Reading}$$

7.6.2 Measurement Results

Results are shown below.

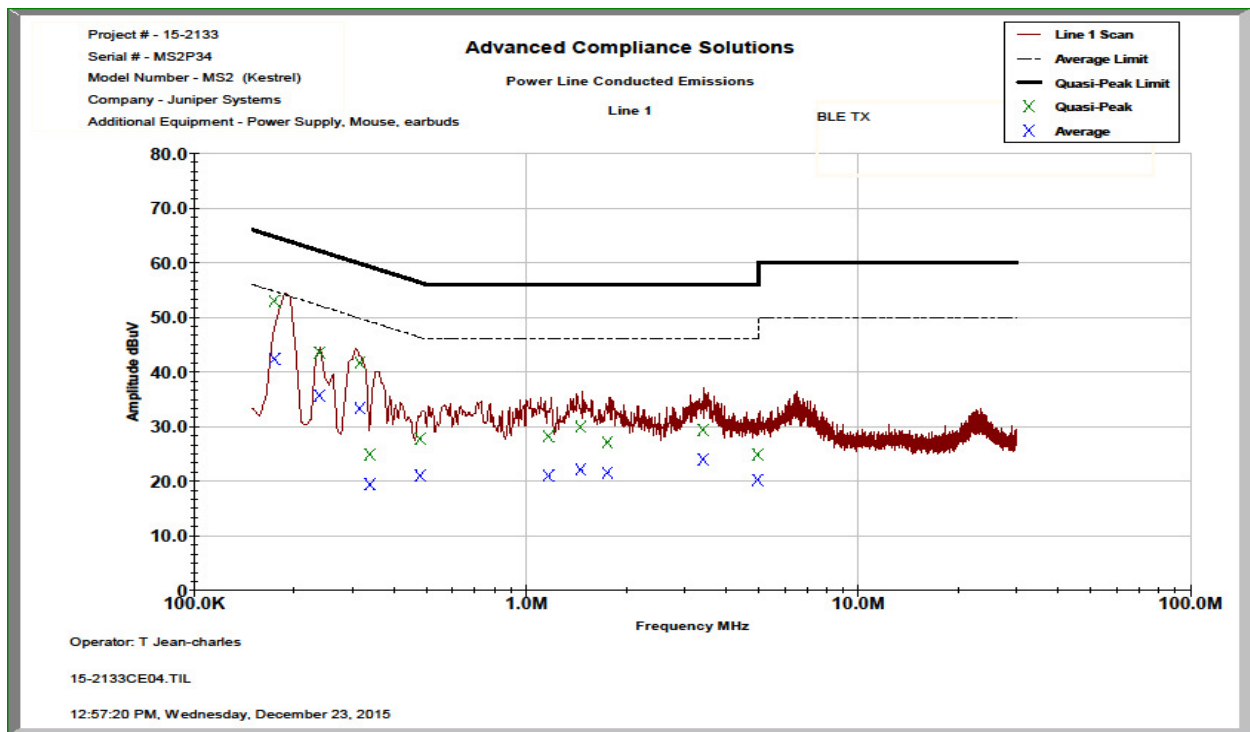

Figure 7.6.2-1: Conducted Emissions Results – Line 1

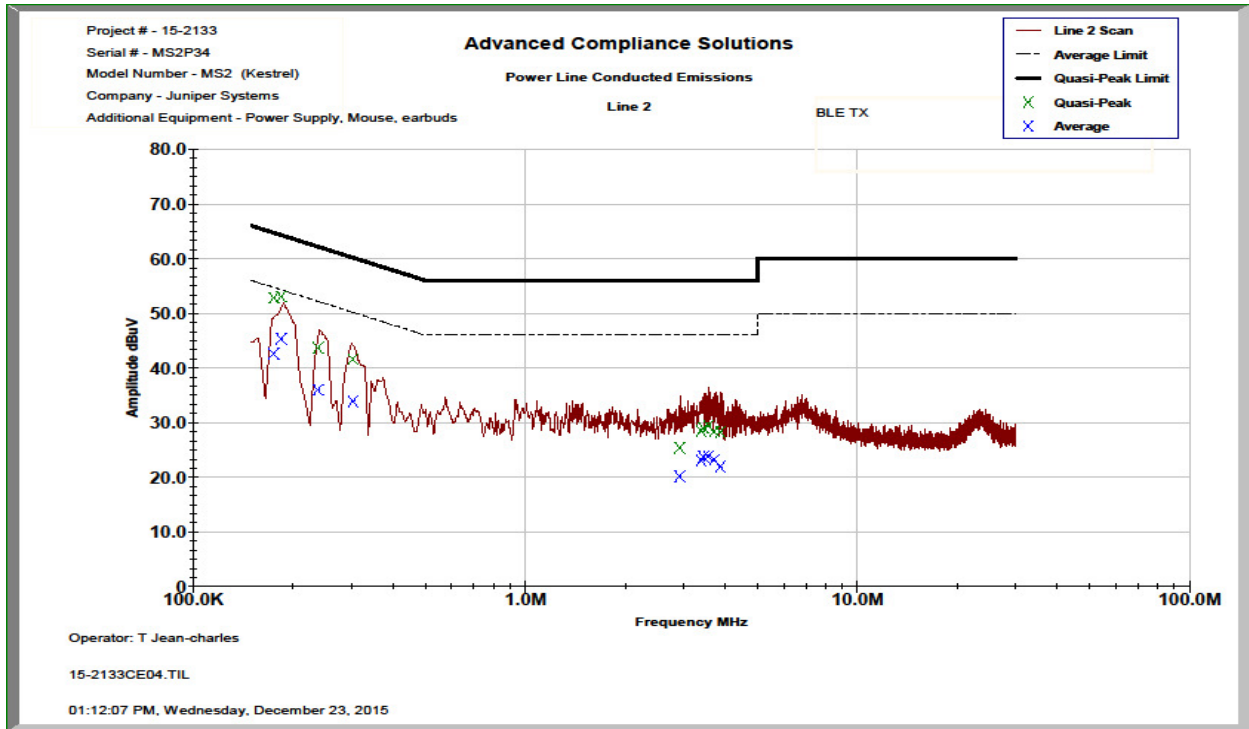

Figure 7.6.2-2: Conducted Emissions Results – Line 2

Table 7.6.2-1: Conducted EMI Results

Line 1    Line 2    Line 3  
 Line 4  
 To Ground    Floating  
 Telecom Port \_\_\_\_\_  
 dB $\mu$ V    dB $\mu$ A  
  
 Plot Number: 15-2133CE04  
 Power Supply Description: 12 VDC

Frequency (MHz)	Uncorrected Reading		Total Correction Factor (dB)	Corrected Level		Limit		Margin (dB)	
	Quasi-Peak	Average		Quasi-Peak	Average	Quasi-Peak	Average	Quasi-Peak	Average
<b>Line 1</b>									
0.174663	42.796	32.149	10.20	53.00	42.35	64.74	54.74	11.7	12.4
0.238899	33.389	25.491	10.21	43.60	35.70	62.13	52.13	18.5	16.4
0.315763	31.454	23.119	10.20	41.66	33.32	59.82	49.82	18.2	16.5
0.338949	14.709	9.21	10.20	24.91	19.41	59.23	49.23	34.3	29.8
0.479999	17.583	10.798	10.21	27.79	21.01	56.34	46.34	28.5	25.3
1.16729	18.005	10.76	10.20	28.21	20.96	56.00	46.00	27.8	25.0
1.45833	19.706	11.938	10.20	29.91	22.14	56.00	46.00	26.1	23.9
1.75683	16.888	11.347	10.20	27.09	21.55	56.00	46.00	28.9	24.5
3.4135	19.061	13.636	10.35	29.41	23.99	56.00	46.00	26.6	22.0
4.98	14.465	9.839	10.39	24.86	20.23	56.00	46.00	31.1	25.8
<b>Line 2</b>									
0.174932	42.64	32.397	10.22	52.86	42.62	64.72	54.72	11.9	12.1
0.184262	42.809	35.139	10.22	53.03	45.36	64.29	54.29	11.3	8.9
0.2379	33.458	25.78	10.22	43.67	36.00	62.17	52.17	18.5	16.2
0.30315	31.376	23.689	10.21	41.59	33.90	60.16	50.16	18.6	16.3
2.92097	15.023	9.796	10.32	25.34	20.11	56.00	46.00	30.7	25.9
3.39111	18.03	12.681	10.39	28.42	23.07	56.00	46.00	27.6	22.9
3.44335	18.627	13.338	10.39	29.02	23.73	56.00	46.00	27.0	22.3
3.56275	18.995	13.436	10.39	29.39	23.83	56.00	46.00	26.6	22.2
3.712	17.972	12.798	10.39	28.36	23.19	56.00	46.00	27.6	22.8
3.86871	17.831	11.476	10.39	28.22	21.87	56.00	46.00	27.8	24.1



**8 CONCLUSION**

In the opinion of ACS, Inc., the models MS2G and MS2GC manufactured by Juniper Systems, Inc. meet the requirements of FCC Part 15 subpart C and Industry Canada's Radio Standards Specification RSS-247 for the test procedures documented in the test report.

**END REPORT**