



**Add value.
Inspire trust.**

Report On

Limited Testing of the
Jotron AS Tron 40VDR
In accordance with Cospas-Sarsat T.007



TÜV SÜD, Octagon House, Concorde Way, Segensworth North,
Fareham, Hampshire, United Kingdom, PO15 5RL
Tel: +44 (0) 1489 558100. Website: www.tuv-sud.co.uk

REPORT ON

Limited Testing of the
Jotron AS
Tron 40VDR

Document 75941540 Report 01 Issue 5

June 2019

PREPARED FOR

Jotron AS
PO Box 23
NO-3195 Skoppum
Norway

PREPARED BY

A handwritten signature in black ink, appearing to read 'M. Hardy'.

Martin Hardy
Engineer

APPROVED BY

A handwritten signature in black ink, appearing to read 'N. Grigsby'.

Nigel Grigsby
Authorised Signatory

DATED

10 June 2019





CONTENTS

Section	Page No
1	REPORT SUMMARY 3
1.1	Introduction 4
1.2	Application Form 5
1.3	Product Information 13
1.4	Test Locations 17
1.5	Modifications 17
1.6	Report Modification Record 17
2	TEST DETAILS 18
2.1	Power Output 30
2.2	Digital Message 33
2.3	Modulation 37
2.4	406 MHz Transmitted Frequency 40
2.5	Spurious Emission into 50 Ohms 47
2.6	406 MHz VSWR Check 50
2.7	Self-test Modes 56
2.8	Thermal Shock 63
2.9	Operating Lifetime at Minimum Temperature (Battery Current Measurements Only) 68
2.10	Frequency Stability Test with Temperature Gradient 88
2.11	Satellite Qualitative Tests 93
2.12	Beacon Antenna Test (EIRP Recalculation Only) 97
2.13	Navigation System Test 101
3	TEST EQUIPMENT USED 105
3.1	Test Equipment 106
4	PHOTOGRAPHS 109
4.1	Photographs of Equipment Under Test (EUT) 110
5	ACCREDITATION, DISCLAIMERS AND COPYRIGHT 114
5.1	Accreditation, Disclaimers and Copyright 115
ANNEX A	Manufacturer Supplied Information A.2



SECTION 1

REPORT SUMMARY

Limited Testing of the
Jotron AS
Tron 40VDR



1.1 INTRODUCTION

The information contained in this report is intended to show verification of the Jotron AS Tron 40VDR to limited requirements of Cospas-Sarsat T.007.

Objective	To perform Emergency Beacon Testing to determine the Equipment Under Test's (EUT's) compliance with the Test Specification, for the series of tests carried out.
Manufacturer	Jotron AS
Model Number(s)	Tron 40VDR
Serial Number(s)	11979 11975
Number of Samples Tested	2
Test Specification/Issue/Date	Cospas-Sarsat T.007 Issue 05 May 2017
Incoming Release Date	Application Form
Date of Receipt of Test Samples	30/01/2018
Order Number	P16206
Date	29 January 2018
Start of Test	31 January 2018
Finish of Test	28 April 2019
Name of Engineer(s)	M Hardy A Uminski
Related Documents	Cospas-Sarsat T.001 Issue 4 revision 1 December 2017 Cospas-Sarsat T.IP (TCXO) Issue 1 Rev 5 Oct 2013



1.2 APPLICATION FORM

G.1 INFORMATION PROVIDED BY THE BEACON MANUFACTURER

Beacon Manufacturer and Beacon Model

Beacon Manufacturer	Jotron AS
Beacon Model Name	TRON 40VDR
Additional Beacon Model Names	

Beacon Type and Operational Configurations

Beacon Type	Beacon used while:	Tick where appropriate
EPIRB Float Free	Floating in water or on deck or in a safety raft	
EPIRB Non-Float Free (automatic and manual activation)	Floating in water or on deck or in a safety raft	
EPIRB Non-Float Free (manual activation only)	Floating in water or on deck or in a safety raft	
EPIRB Float Free with VDR	Floating in water or on deck or in a safety raft	X
PLB	On ground and above ground	
	On ground and above ground and floating in water	
ELT Survival	On ground and above ground	
	On ground and above ground and floating in water	
ELT Auto Fixed	Fixed ELT with aircraft external antenna	
ELT(DT)	Distress Tracking ELT with aircraft external antenna	
ELT Auto Portable	In aircraft with an external antenna	
	On ground, above ground, or in a safety raft with an integrated antenna	
ELT Auto Deployable	Deployable ELT with attached antenna	
Other (specify)		



Beacon Characteristics

Characteristic	Specification
Operating frequency	406.037 MHz
Operating temperature range	$T_{min} = -20^{\circ}\text{C}$ $T_{max} = +55^{\circ}\text{C}$
Temperature, at which minimum duration of continuous operation is expected	-20°C
Operating lifetime	168 hours
Beacon power supply type (internal non-rechargeable, internal re-chargeable, external, combined, other)	internal non-rechargeable
External power supply parameters (AC/DC and nominal voltage)	
Is external power supply needed to energise the beacon or its ancillary devices in any of operational modes (N/A or Yes or No)	N/A
Battery cell chemistry	Lithium-thionyl chloride (Li-SOCI ₂)
Battery cell model name, cell size, number of cells in a battery pack, and details of the battery pack electrical configuration	LSH14 light, C-size, 10cells, 5 batteries in parallel each with 2 cells in serial.
Battery cell manufacturer	SAFT
Battery pack manufacturer and part number	Jotron AS, X-87457
Beacon manufacturers declared maximum allowed cell shelf-life (from date of cell manufacture to date of battery pack installation in the beacon)	2,5 years
Declared beacon battery replacement period (from date of installation in the beacon to expiry date marked on the beacon)	5 years
Oscillator type (e.g. OCXO, MCXO, TCXO)	TCXO
Oscillator manufacturer	RAKON
Oscillator model name/ part number	E4520L
Oscillator satisfies long-term frequency stability requirements (Yes or No)	Yes
Antenna type: Integral or Other (e.g. External, Detachable – specify type)	Integral
Antenna manufacturer	Jotron AS
Antenna part name and part number	X-83053
Antenna cable assembly min/max RF- losses at 406 MHz, if applicable	



Characteristic	Specification
Navigation device type (Internal, External or None)	Internal
Features in beacon that prevent degradation to 406 MHz signal or beacon lifetime resulting from a failure of navigation device or failure to acquire position data (Yes, No, or N/A)	Yes
Features in beacon that ensure erroneous position data is not encoded into the beacon message (Yes, No or N/A)	Yes
Navigation device capable of supporting global coverage (Yes, No or N/A)	Yes
Encoded position update capability (Yes, No, N/A) and	Yes
Encoded position update interval value (range)	6-16 min
For Internal Navigation Devices	
- Geodetic reference system (WGS 84 or GTRF)	WGS 84
- GNSS receiver cold start forced at every beacon activation (Yes or No)	Yes
- Navigation device manufacturer	uBlox
- Navigation device model name and part Number	MAX-7Q-0
- Internal navigation device antenna type(integrated, internal, external, passive/active) , manufacturer and model	Internal, Allis Comm. GPS-P1P
- GNSS system supported (e.g. GPS, GLONASS, Galileo)	GPS/QZSS L1 C/A, GLONASS L1 FDMA
For External Navigation Devices	
- Data protocol for GNSS receiver to beacon interface	
- Physical interface for beacon to navigation device	
- Electrical interface for beacon to navigation device	
- Part number of the external navigation interface device (if applicable)	
- Navigation device model and manufacturer (if beacon designed to use specific devices)	



Self-Test Mode Characteristics:	Self-Test Mode	Optional GNSS Self-test Mode
- Activated by a separate switch/ separate switch position (Yes or No)	Yes	No
- Self-test/GNSS self-test mode switch automatically returns to normal position when released (Yes or No)	Yes	Yes
- Self-test/ GNSS self-test activation can cause an operational mode transmission (Yes or No)	No	No
- Results in transmission of a single self-test burst only, regardless of how long the self-test activation mechanism is applied (Yes or No)	Yes	Yes
- Results of self-test/ GNSS self-test are indicated by (provide details, e.g. Pass / Fail indicator light, strobe light, etc.)	Number of Strobe light flashes. One flash=OK	Number of Strobe light flashes + audio beep's. Two beep=Pos received. One flash=Selftest OK
- The content of the encoded position data fields of the self-test message has default values	Yes	N/A
- Performs an internal check and indicates that RF-power is being emitted at 406 MHz and 121.5 MHz, if beacon includes a 121.5 Hz homer (Yes or No)	Yes	Yes
- Self-test results in transmission of a signal other than at 406 MHz (Yes & details or No)	Yes, 121.5MHz	Yes, 121.5MHz
- Self-test can be activated directly at beacon (Yes or No)	Yes	Yes
- List of Items checked by self-test	Supported in product manuals	Supported in product manuals
- Self-test/ GNSS self-test 406 MHz burst duration (440 or 520 ms)	520ms	520ms
- Self-test message length format flag in bit 25, ("0" or "1")	"1"	"1"
- Maximum duration of a self-test mode, sec	17 sec. if OK and no GNSS test	130 sec. for GNSS and 6sec. for self-test
- Maximum recommended number of self-tests during battery pack replacement period	60	N/A
- Distinct indication of self-test start (Yes or No)	Yes. The user must hold the switch in test position	Yes
- Indication of self-test results(Yes or No)	Yes	Yes
- Distinct indication of insufficient battery capacity (Yes or No)	No	No
- Automatic termination of self-test mode immediately after completion of the self-test cycle (Yes or No)	Yes	Yes



- Maximum number of GNSS Self Tests (beacons with internal navigation devices only)	N/A	60	
Self-Test Mode Characteristics:	Self-Test Mode	Optional GNSS Self-test Mode	
- GNSS Self-test results in transmission of a single burst, irrespectively of the test result (Yes or No)	N/A	No. Not if GNSS test fails.	
- Maximum number of self-tests during battery pack replacement period	No limit	N/A	
- Self-test/ GNSS self-test can be activated from beacon remote activation points (Yes & details or No)			
- List all methods of Self-test mode and GNSS Self-test modes activation. Provide details on a separate sheet to describe	Move and hold switch in TEST position for 15 sec	Move switch to TEST position twice within 3 sec. and release.	
Message Coding Protocols:	(x) Tick the boxes below against the intended protocol options		
User Protocol (tick where appropriate)	<input type="checkbox"/>	Maritime with MMSI	
	<input type="checkbox"/>	Maritime with Radio Call Sign	
	<input type="checkbox"/>	EPIRB Float Free with Serial Number	
	<input type="checkbox"/>	EPIRB Non Float Free with Serial Number	
	<input type="checkbox"/>	Radio Call Sign	
	<input type="checkbox"/>	Aviation	
	<input type="checkbox"/>	ELT with Serial Number	
	<input type="checkbox"/>	ELT with Aircraft Operator and Serial Number	
	<input type="checkbox"/>	ELT with Aircraft 24-bit Address	
	<input type="checkbox"/>	PLB with Serial Number	
	<input type="checkbox"/>	National (Short Message Format)	
	<input type="checkbox"/>	National (Long Message Format)	
	Standard Location Protocol (tick where appropriate)	<input checked="" type="checkbox"/>	EPIRB with MMSI
		<input checked="" type="checkbox"/>	EPIRB with Serial Number
<input type="checkbox"/>		ELT with 24-bit Address	
<input type="checkbox"/>		ELT with Aircraft Operator Designator	
<input type="checkbox"/>		ELT with Serial Number	
National Location Protocol (tick where appropriate)	<input type="checkbox"/>	PLB with Serial Number	
	<input type="checkbox"/>	National Location: EPIRB	
	<input type="checkbox"/>	National Location: ELT	
ELT(DT) Location Protocol (tick where appropriate)	<input type="checkbox"/>	National Location: PLB	
	<input type="checkbox"/>	ELT with Serial Number	
	<input type="checkbox"/>	ELT with Aircraft Operator and Serial Number	
	<input type="checkbox"/>	ELT with Aircraft 24-bit Address	
	<input type="checkbox"/>	EPIRB	



RLS Location Protocol (tick where appropriate) *	ELT
	PLB
User Location Protocol (tick where appropriate)	Maritime with MMSI
	Maritime with Radio Call Sign
	EPIRB Float Free with Serial Number
	EPIRB Non Float Free with Serial Number
	Radio Call Sign
	Aviation
	ELT with Serial Number
	ELT with Aircraft Operator and Serial Number
	ELT with Aircraft 24-bit Address
	PLB with Serial Number
Beacon includes a homer transmitter(s) (Yes or No)	
- homer transmitter(s) frequency	<u>121.5</u> MHz
- homer transmitter(s) power	<u>17dBm±3dBm</u>
- homer transmitter(s) duty cycle	<u>96</u> %
- duty cycle of homer swept tone	<u>37</u> %
Beacon includes a high intensity flashing light (e.g. Strobe)	Yes or No Yes
- light intensity	<u>>0.7</u> cd
- flash rate	<u>21</u> flashes per minute
Beacon transmission repetition period satisfies C/S T.001 requirement that two beacon's repetition periods are not synchronised closer than a few seconds over 5 minute period, and the time intervals between transmissions are randomly distributed on the interval 47.5 to 52.5 seconds (Yes or No)	Yes
Other ancillary devices (e.g. voice transceiver, remote control, external audio and light indicators, external activation device). List details on a separate sheet if insufficient space to describe.	No
Beacon includes automatic activation mechanism (Yes or No). Specify type of automatic beacon activation mechanism	Yes. Water contacts

* By decision of the Cospas-Sarsat Council at its Fifty-Seventh Session, RLS protocols will be effective as of [1 January 2018], as a target, subject to further review and consideration. The use of RLS-enabled beacons will be regulated by national administrations.



Beacon includes a voice-transceiver (Yes or No) - provides prevention against continuous operation of voice transmitter (Yes or No), and if Yes specify: - maximum continuous voice-transmission duration (limit), minutes - Manufacturer-specified total duration of voice-transmitter operation during the declared rated lifetime ("On time"), (hrs)	No
Beacon includes features and functions not listed above, related or non-related to 406 MHz (Yes or No) List features and use a separate sheet if insufficient space	Yes. VDR storage module
Beacon model hardware part number (P/N) and version	X-87910
Beacon model software/firmware P/N, version, date of issue/releases	X-87934, SW ver 2.1.3, May 12. 2017
Beacon model printed circuit board P/N and version	X-87454, R1726
Known non-compliances with C/S T,001 requirements(Yes or No) If Yes, provide details (or use a separate sheet if insufficient space)	No
Beacon Manufacturer Point of Contact (POC) for this Type Approval application:	Name and Job Title: Frank Løke Certification Manager Phone: +47 90 013 051 E-mail: Frank.loke@jotron.com

Dated: 10.12.2018 Signed: Frank Løke, Certification Manager 
(Name, Position and Signature of Beacon Manufacturer Representative)



(Continued on Next Page)



1.2.1 Information Provided by the Cospas-Sarsat Accepted Test Facility

Name and Location of Beacon Test Facility: TÜV SÜD, United Kingdom

Date of Submission for Testing: December 2017

Applicable C/S Standards:

Document	Issue	Revision	Date
C/S T.001	4	1	May-17
C/S T.007	5	-	May-17

I hereby confirm that the 406 MHz beacon described above has been tested in accordance with the Cospas-Sarsat Type Approval Standard (C/S T.007) and with the Specification for Cospas-Sarsat 406 MHz Distress Beacons (C/S T.001) noting the deviations and non-compliances stated below:

Deviations: None

Non-compliances:

Section 2.3 – Modulation. Measurements exceed the limit of C/S T.007 – however, the results are within the Test Facility Accuracy stated in C/S T.008.

Section 2.6 – Modulation under VSWR conditions. Measurements exceed the limit of C/S T.007 – however, the results are within the Test Facility Accuracy stated in C/S T.008.

Section 2.7 – Self-Test – observations: no distinct indication of Self-Test provided by the EUT.

Section 2.7 – Self-Test – Self-Test and GNSS Self-Test do not automatically terminate with the EUT switch held in the 'TEST' position.

Signed: 

Name: Nigel Grigsby

Position Held: Authorised Signatory

Date: 10 June 2019

1.3 PRODUCT INFORMATION

1.3.1 Technical Description

The Equipment Under Test (EUT) was a Jotron AS Tron 40VDR as shown in the photograph below. A full technical description can be found in the manufacturer's documentation.



Equipment Under Test

1.3.2 Physical Test Configuration

The Equipment Under Test (EUT) was operated using its own power source (internal battery). One EUT was configured so that the antenna port was connected to the 50 Ω test system using a coaxial cable. The test configuration for all tests is identical with the exception of Satellite Qualitative and Position Accuracy Time and Position Accuracy. This EUT was modified to allow a 50 Ω impedance output. To achieve this, the manufacturer bypassed a matching network integral to the EUT. This resulted in a higher output power that required correcting in accordance with the manufacturers data supplied in Annex A.

The second EUT was a fully packaged beacon, similar to the proposed production beacons equipped with its proper antenna. This EUT was used to perform Satellite Qualitative and Position Acquisition Time and Position Accuracy. The test configuration for these tests is a function of the beacon type and the operational environments supported by the beacon, as declared by the manufacturer.



System Configurations

For all conducted measurement tests (unless otherwise stated), the EUT was configured with the VDR module fitted to the base of the EUT. To enable data to be sent to the VDR module, the EUT was fitted into a Float Free Case Docking Module, as shown in the setup information shown below. (Information is transferred to the VDR module via the Float Free case). Battery Current and Position Accuracy Time and Position Accuracy were repeated with the EUT in 'Stand Alone' configuration. Other Navigation tests were performed in an anechoic chamber with the EUT in standalone configuration. All test configurations are shown in the photographs in Section 4 of this report.

The test time interval was extended, and consecutive 406 MHz bursts were measured over 35 minutes for the following tests:

- Transmitter power output
- Digital message
- Digital message generator
- Modulation
- 406 MHz transmitted frequency
- 406 MHz VSWR check

This was to ensure that measurements were made during the operating modes described in section 1.3.3. The manufacturer advised that after the first burst from switch on, the GPS receiver operates in the following duty cycle: On for 2 minutes, Off for 6 minutes, On for 2 minutes, Off for 7* minutes... (in the absence of a GPS signal). A test time of 35 minutes includes at least 4 cycles of the GPS receiver operation.

* The Off time increments by 1 minute each cycle, up to a maximum of 16 minutes.
The EUT tested for Frequency Stability with Temperature Gradient was fitted with a TCXO, Model: E4520, S/No: 0200.

Conducted Laboratory Tests

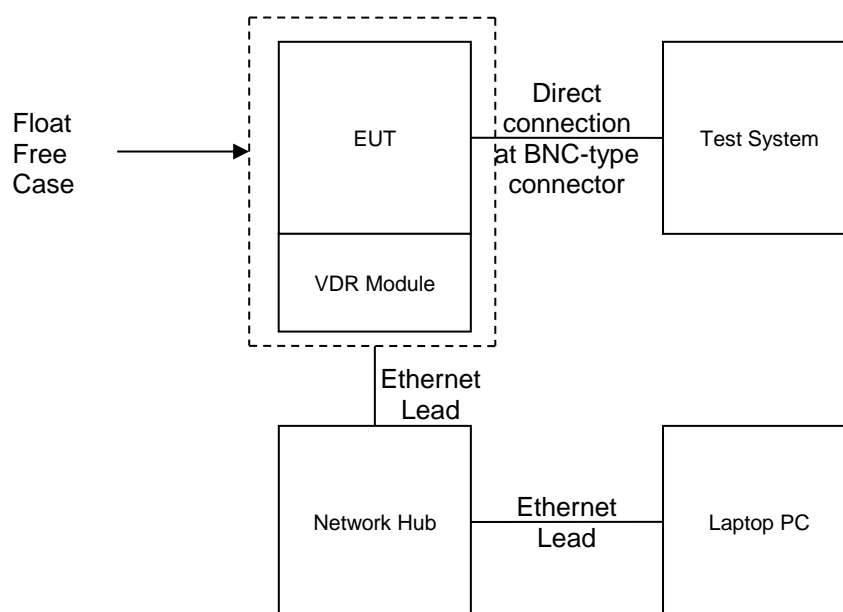

Navigation Tests

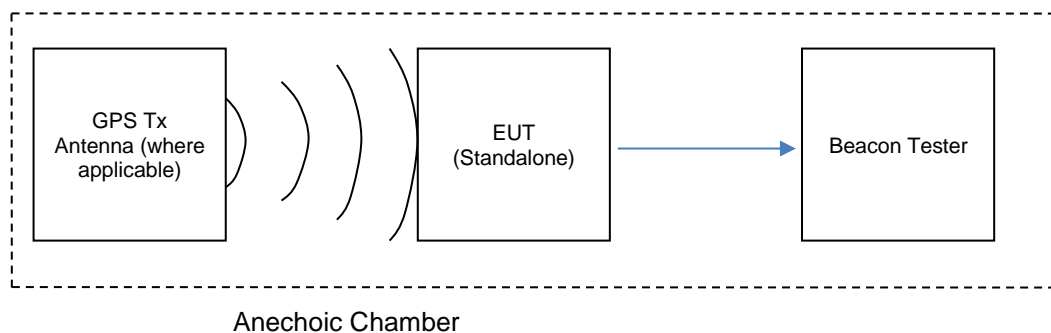

Battery Current Measurements

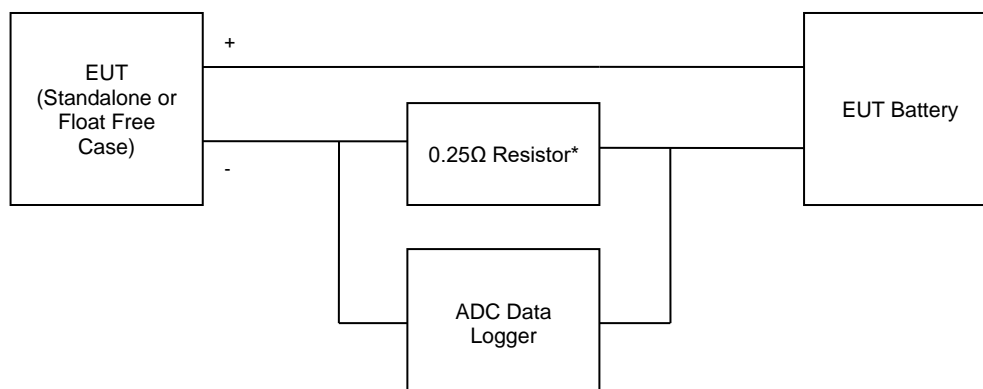

Note: The resistor in series with negative line of battery

* Removed for Standby mode measurements.

For other Navigation, Satellite and Antenna test configurations, see photographs in section 4 of this report.

Further Information

The EUT tested in this report has been subjected to limited testing. The test schedule was previously agreed between the Manufacturer and Cospas Sarsat.



1.3.3 Modes of Operation

Modes of operation of the EUT during testing were as follows:

Off/Standby Mode

- Main switch to “READY” position

Self-test

- Main Switch to “TEST” position (hold for 15 seconds)
- List of items checked as per Customer Supplied Information (Application Form)
- Additional Information supplied in Annex A

GNSS Self-test

- Main Switch to “TEST” position (twice in 3 seconds)
- List of items checked as per Customer Supplied Information (Application Form)
- Navigation data applied as applicable (e.g. none applied for timeout, data applied for ‘fast acquisition’)
- Additional Information supplied in Annex A

Operating

- Main switch to “ON” position
- 121 Homer active and offset
- GPS operating in normal duty cycle
- Physical configuration as below

All modes

All mode descriptions are applicable to all tests unless otherwise stated. Additional methods of activation include:

- Water contacts

All Navigation input descriptions are applicable to all tests unless otherwise stated.



1.4 TEST LOCATIONS

Satellite Qualitative/Navigation test A.3.8.2.1: Daedalus Airfield, Lee-on-the-Solent, Hants, UK
All other tests: Octagon House Laboratory, Fareham, Hampshire, UK

1.5 MODIFICATIONS

Modification 0 - No modifications were made to the test sample during testing.

Modification 1 – Capacitor change to eliminate strobe flash during GNSS Self-Test at +55°C
(Additional details supplied by manufacturer).

1.6 REPORT MODIFICATION RECORD

Issue 1 – First Issue

Issue 2 – Additional battery current measurement information/rewording. Automatic termination of Self-Test checks. Tables F.E-3 and F.E-4 added. EIRP recalculation. Satellite Qualitative test in MS1 carried out. Beacon Coding Software test data (supplied by Manufacturer) reviewed and added.

Issue 3 – Beacon Coding Software test data (supplied by Manufacturer) reviewed and added. Revised application form (supplied by Manufacturer).

Issue 4 – Test Facility Measurement Uncertainty Values presented on page B.4 (Annex B). Modification State 1 Battery Current measurement comparison presented on page B.2 (Annex B). Modification State 1 pre-test discharge recalculation presented on page B.3 (Annex B). Beacon Coding Software provided by the Manufacturer and presented on page A.22 of Annex A. EIRP recalculation presented in section 2.12. Satellite Qualitative test in Modification State 1 presented in section 2.11. For Antenna Test recalculation, additional comments have been added to section 2.12.6 regarding the Modification States for values used in the calculations. Residual current measurements for Self-Test and GNSS Self-Test presented in the Battery Current Measurements section on pages 76 and 77, with additional comments added to page 80. Table F.E-4: Step 1 'Description of action/indication' comment changed. Summary comments modified on page 62. Comments regarding GNSS Self-Test modified on page 77.

Issue 5 – Operating lifetime test data added to section 2.9 (general test campaign parameters revised in section 1.1, test summary table and section 3.1 (test equipment), including battery current measurements). Corrected numerous formatting errors.



SECTION 2

TEST DETAILS

Limited Testing of the
Jotron AS
Tron 40VDR



TEST RESULTS TABLE

Parameters to be Measured	Range of Specification	Units	Test Results			Comments
			Tmin	Tamb	Tmax	
			(-20°C)	(+21°C)	(+55°C)	
1. Power Output						
Model: Tron 40VDR, S/N: 11979, TUV Ref: TSR2 and Modification State 0						
Transmitter power output (maximum)	35 - 39	dBm	38.55* (36.77)	37.87* (36.09)	38.27* (36.49)	* In accordance with the manufacturer documentation, 1.78dB needs to be deducted from all power measurements, due to the exclusion of a matching network to modify the EUT to a 50ohm conducted output. Adjusted figure in brackets.
(minimum)			38.48* (36.70)	37.82* (36.04)	38.24* (36.46)	
Power output rise time (maximum)	< 5	ms	0.03	0.03	0.03	
(minimum)			0.02	0.02	0.02	
Power output 1ms before burst (maximum)	< -10	dBm	-35.94	-37.18	-36.31	
(minimum)			-37.19	-38.10	-37.45	
2. Digital Message Coding						
Model: Tron 40VDR, S/N: 11979, TUV Ref: TSR2 and Modification State 0						
Bit Sync	1 - 15	15 bits "1"	P / F	P	P	P
Frame sync	16 - 24	"000101111"	P / F	P	P	P
Format flag	25	1 bit	bit value	1	1	1
Protocol flag	26	1 bit	bit value	0	0	0
Identification / position data	27 - 85	59 bits	P / F	P	P	P
BCH code	86 -106	21 bits	P / F	P	P	P
Emerg. Code/nat. use/supplem. Data	107 - 112	6 bits	bit value	110111	110111	110111
Additional data / BCH (if applicable)	112 - 144	32 bits	P / F	P	P	P
Position Error (if applicable)	< 5		km	n/a	n/a	n/a



Parameters to be Measured	Range of Specification	Units	Test Results			Comments
			Tmin	Tamb	Tmax	
			(-20°C)	(+21°C)	(+55°C)	
3. Digital Message Generator						Result: Pass
Model: Tron 40VDR, S/N: 11979, TUV Ref: TSR2 and Modification State 0						
Repetition rate, T _R :						
Average T _R	48.5 ≤ T _{Ravg} ≤ 51.5	seconds	49.900	50.169	50.003	
Minimum T _R	47.5 ≤ T _{Rmin} ≤ 48.0	seconds	47.628	47.580	47.658	
Maximum T _R	52.0 ≤ T _{Rmax} ≤ 52.5	seconds	52.447	52.463	52.448	
Standard deviation	0.5 - 2.0	seconds	1.72	1.72	1.55	
Bit rate						
Minimum fb	≥ 396	bits/sec	399.71	399.71	399.71	
Maximum fb	≤ 404	bits/sec	399.72	399.72	399.72	
Total transmission time						
Short message	(maximum) 435.6 - 444.4	ms	N/A	N/A	N/A	
Long message	(maximum) 514.8 - 525.2	ms	519.97	519.95	519.97	
Unmodulated carrier	(minimum)		519.88	519.88	519.89	
Minimum T1	≥ 158.4	ms	160.55	160.57	160.56	
Maximum T1	≤ 161.6	ms	160.62	160.64	160.63	
First burst delay	≥ 47.5	seconds	57*	61*	54*	* The EUT transmits a Self-Test burst approximately 6 seconds after activation. The time shown is that of the first normal burst transmitted after activation.



Parameters to be Measured	Range of Specification	Units	Test Results			Comments	
			Tmin	Tamb	Tmax		
			(-20°C)	(+21°C)	(+55°C)		
4. Modulation						Result: Non-Compliance	
Model: Tron 40VDR, S/N: 11979, TUV Ref: TSR2 and Modification State 0							
Biphase-L		P / F	P / F	P	P	P	* Results exceeds the limits of C/S T.007. However, the result is within the Test Facility accuracy stated in C/S T.008.
Rise time	(maximum)	50 - 250	µs	149.4	152.4	148.4	
	(minimum)	50 - 250	µs	145.3	149.3	145.3	
Fall time	(maximum)	50 - 250	µs	148.7	152.7	149.6	
	(minimum)	50 - 250	µs	144.6	149.6	145.6	
Phase deviation: positive	(maximum)	+(1.0 to 1.2)	radians	1.1775	1.1459	1.1699	
	(minimum)	+(1.0 to 1.2)	radians	1.0545	1.0590	1.0460	
Phase deviation: negative	(maximum)	-(1.0 to 1.2)	radians	-1.1742	-1.1713	-1.2242*	
	(minimum)	-(1.0 to 1.2)	radians	-1.0694	-1.0935	-1.0965	
Symmetry measurement		≤ 0.05		0.0260	0.0256	0.0260	
5. 406 MHz Transmitted Frequency						Result: Pass	
Model: Tron 40VDR, S/N: 11979, TUV Ref: TSR2 and Modification State 0							
Nominal Value	(maximum)	C/S T.001	MHz	406.0369858	406.0369518	406.0368861	
	(minimum)			406.0369857	406.0369512	406.0368860	
Short-term stability	(maximum)	≤ 2x10 ⁻⁹	/100ms	42.127E-11	33.869E-11	41.749E-11	
	(minimum)			31.461E-11	27.720E-11	30.888E-11	
Medium-term stability – Slope	(maximum)	(-1 to +1)x10 ⁻⁹	/minutes	26.910E-12	11.088E-11	22.107E-12	
	(minimum)			-22.703E-12	94.313E-13	-27.156E-12	
Medium-term stability – Residual frequency variation	(maximum)	≤ 3x10 ⁻⁹		32.959E-11	39.909E-11	38.047E-11	
	(minimum)			25.458E-11	30.398E-11	21.202E-11	
6. Spurious Emissions into 50ohms						Result: Pass	
Model: Tron 40VDR, S/N: 11979, TUV Ref: TSR2 and Modification State 0							
In band (406.0 – 406.1 MHz)		C/S T.001 mask	P / F	P	P	P	



Parameters to be Measured	Range of Specification	Units	Test Results			Comments	
			Tmin	Tamb	Tmax		
			(-20°C)	(+21°C)	(+55°C)		
7. 406 MHz VSWR Check						Result: Non-Compliance	
Model: Tron 40VDR, S/N: 11979, TUV Ref: TSR2 and Modification State 0							
Nominal Value	(maximum) (minimum)	C/S T.001	MHz	406.0369842 406.0369813	406.0369518 406.0369517	406.0368944 406.0368940	* Results exceeds the limits of C/S T.007. However, the result is within the Test Facility accuracy stated in C/S T.008.
Modulation rise time	(maximum) (minimum)	50-250	µs	148.4 144.3	152.4 149.3	149.4 145.3	
Modulation fall time	(maximum) (minimum)	50-250	µs	148.7 144.6	152.7 148.6	149.6 145.6	
Modulation phase deviation: positive	(maximum) (minimum)	+ (1.0 to 1.2)	radians	1.1983 1.0500	1.1475 1.0641	1.1642 1.0477	
Modulation phase deviation: negative	(maximum) (minimum)	- (1.0 to 1.2)	radians	-1.1995 -1.0636	-1.1710 -1.0904	-1.2219* -1.0957	
Modulation symmetry measurement	≤ 0.05			0.0256	0.0256	0.0252	
Digital Message	correct		P / F	P	P	P	



Parameters to be Measured	Range of Specification	Units	Test Results			Comments
			Tmin	Tamb	Tmax	
			(-20°C)	(+21°C)	(+55°C)	
8(a). Self-test Mode					Result: Non-Compliance	
Model: Tron 40VDR, S/N: 11979, TUV Ref: TSR2 and Modification State 1						
Frame sync	011010000	P / F	P	P	P	Test at ambient with GPS data present. The EUT strobe light emitted one flash, indicating that the Self-Test passed successfully
Format flag	1 / 0	bit value	1	1	1	
Single radiated burst	≤440 / 520 (±1%)	ms	519.921	519.863	519.907	
Default position data (if applicable)	correct	P / F	P	P	P	
Description	provided	Y / N	Y			
Design data on protection against repetitive self-test mode transmissions	provided	Y / N	Y			
Single burst verification	one burst	P / F	P	P	P	
Provides for 15 Hex ID	correct	P / F	P	P	P	
121.5 MHz RF power (if applicable)	verify that RF power emitted	P / F	P	P	P	
406 MHz power	verify that RF power emitted	P / F	P	P	P	
Distinct indication of Self-Test	provided	Y / N	N*	N*	N*	* In accordance with the manufacturer's information, a Self-Test was initiated by holding the activation switch in the 'TEST' position for 15 seconds. The EUT strobe flashed once to indicate completion of a satisfactory Self-Test. *Whilst there was no clear indication that RF power has been emitted, output RF power is one of the parameters checked during the Self-Test procedure.
Distinct indication of RF power being emitted	provided	Y / N	N*	N*	N*	
Indication of Self-Test result	provided	Y / N	Y	Y	Y	
Maximum duration of Self-Test mode	≤ maximum duration of Self-Test	sec	12	12	12	The manufacturer operating manual advises that the EUT strobe will flash more than once if a fault is found. The number of flashes depends on the type of fault.
Automatic termination of Self-Test mode upon completion of Self-Test and indication of Self-Test results	verify automatic termination, irrespective of switch position	Y / N	N	N	N	



Parameters to be Measured	Range of Specification	Units	Test Results			Comments
			Tmin	Tamb	Tmax	
			(-20°C)	(+21°C)	(+55°C)	
8 (b). GNSS Self-Test Mode (if applicable)						Result: Non-Compliance
Model: Tron 40VDR, S/N: 11979, TUV Ref: TSR2 and Modification State 1						
Frame sync	011010000	P / F	P	P	P	For detailed test results and observations, see test report section 2.7.
Format flag	1 / 0	bit value	1	1	1	
Radiated burst duration	≤ 520 (+1%)	ms	519.914	519.932	519.913	
Position data except for ELT (DT) (if applicable)	must be within 500 m (or 5.25 km for User Location Protocol) of the actual position	P / F	P	P	P	See manufacturer supplied information – Annex A
Position data for ELT(DT)	must be within 200 m of the actual horizontal position and 700 m of the altitude	P / F	N/A	N/A	N/A	
Design data showing how GNSS Self-test is limited in number of transmissions and duration	provided	Y / N		Y		
Single burst verification (if applicable)	one burst	P / F	P	P	P	Manufacturer specified value: 130
121.5 MHz RF power (if applicable)	verify that RF power is emitted	Y / N	Y	Y	Y	
406 MHz power (if applicable)	verify that RF power is emitted	Y / N	Y	Y	Y	
Maximum duration of GNSS Self-tests	Manufacturer to specify value	s	125	125	125	Manufacturer specified number: 60
Actual duration of Self-test with encoded location	Less than maximum duration	s	40	34	45	
Maximum number of GNSS Self-tests (only beacons with internal navigation devices)	Manufacturer to specify number	Number		60		
Distinct indication to register successful completion or failure of the GNSS self-test	must be provided	Y/N	Y	Y	Y	Manufacturer specified number: 60
Distinct indication that a maximum number of GNSS self-tests has been attained after GNSS self-test mode activation and without transmission of a test message or further GNSS receiver current drain	must be provided	Y/N		Y		
Automatic termination of Self-Test mode upon completion of Self-Test and indication of Self-Test results	verify automatic termination, irrespective of switch	Y / N	N	N	N	
						See Battery Current measurements for further information.



Parameters to be Measured	Range of Specification	Units	Test Results			Comments
			Tmin	Tamb	Tmax	
			(-20°C)	(+21°C)	(+55°C)	
	position					
9. Thermal Shock						Result: Pass
Model: Tron 40VDR, S/N: 11979, TUV Ref: TSR2 and Modification State 0						
Soak Temperature	30°C difference	°C	20		* In accordance with the manufacturer documentation, 1.78dB needs to be deducted from all power measurements, due to the exclusion of a matching network to modify the EUT to a 50ohm conducted output. Adjusted figure in brackets.	
Measurement Temperature		°C	-10			
Transmitted Frequency	C/S T.001		Min	Max		
Nominal value		MHz	406.0369791	406.0369824		
Short-term stability		/100ms	27.872E-11	54.039E-11		
Medium-term stability – Slope		/min	-29.735E-11	45.697E-11		
Medium-term stability – Residual frequency variation	≤ 3x10 ⁻⁹		21.914E-11	12.824E-10		
Transmitter power output	35 - 39	dBm	38.27* (36.49)	38.37* (36.59)		
Digital message	correct	P/F	P			



Parameters to be Measured	Range of Specification	Units	Test Results		Comments
10. Operating Lifetime at Minimum Temperature					Result: Pass
Model: Tron 40VDR, S/N: 11979, TUV Ref: TSR2 and Modification State 1					
Pre-test battery discharge duration (operating) required		Hours	88.86		
Pre-test battery discharge duration (operating) Duration	>24	Hours	96		Results reported up to the declared battery duration (168h). End time of the homer transmitter is taken when the output power drops by 3dB.
Effective Operating Lifetime duration	>24	Hours	168 Hours at T _{min} = <u>-20°C</u>		
		Hours	262.81 Hours at T _{min} = <u>-20°C</u>		
Transmitted Frequency			Min	Max	
Nominal value	C/S T.001	MHz	406.0369811	406.03699	
Short-term stability	≤ 2x10 ⁻⁹	/100ms	1.687E-10	5.842E-10	
Medium-term stability – Slope	(-1 to +1)x10 ⁻⁹	/min	-5.999E-11	6.758E-11	
Medium-term stability – Residual frequency variation	≤ 3x10 ⁻⁹		1.318E-10	3.890E-10	
Transmitter power output	35 - 39	dBm	35.86	36.15	
Digital message	correct	P/F	P		
Homer transmitter continuous operation during the lifetime test		hours	271.363889		
			Start of Test	End of Test	
Homer frequency		MHz	121.6004	121.599398	
Homer peak power level		dBm	20.6	20.3	
Homer transmitter duty cycle		%	98.1	30.52	



Parameters to be Measured	Range of Specification	Units	Test Results		Comments
11. Temperature Gradient (5°C/hr)					Result: Pass
Model: Tron 40VDR, S/N: 11979, TUV Ref: TSR2 and Modification State 0					
Full Test					
Transmitted Frequency			Min	Max	Data for points A to B, C+15 min to D and E+15 min to F Data for points B to C+15 min and D to E+15 min * In accordance with the manufacturer documentation, 1.78dB needs to be deducted from all power measurements, due to the exclusion of a matching network to modify the EUT to a 50ohm conducted output. Adjusted figure in brackets.
Nominal value	C/S T.001	MHz	406.0369051	406.0369904	
Short-term stability	$\leq 2 \times 10^{-9}$	/100ms	20.273E-11	57.372E-11	
Medium-term stability – Slope ¹	(-1 to +1) $\times 10^{-9}$	/min	-1.65E-10	9.12E-10	
Medium-term stability – Residual frequency variation	(-2 to +2) $\times 10^{-9}$	/min	-7.50E-10	6.96E-10	
	$\leq 3 \times 10^{-9}$		15.794E-11	29.574E-10	
Transmitter power output	35 – 39	dBm	38.20* (36.42)	38.45* (36.67)	
Digital message	correct	P/F	P		
12. Oscillator Aging					
5 year carrier nominal frequency variation	provided	Y / N	N		See TCXO procedure in Temperature Gradient test results section
MTS analysis (if applicable)	Must demonstrate compliance	P / F	P		
13. Protection Against Continuous Transmission					
Description	provided	Y / N	Y		See manufacturer supplied information – Annex A



Parameters to be Measured	Range of Specification	Units	Test Results				Comments
14. Satellite Qualitative Tests						Result: Pass	
Model: Tron 40VDR, S/N: 11975, TUV Ref: TSR1 and Modification State 0 (Configurations 5 and 7)							
Model: Tron 40VDR, S/N: 11975, TUV Ref: TSR1 and Modification State 1 (Configuration 8)							
Test Configuration	As per C/S T.007		Configuration				
			5	6	7	8	
15 Hex ID Decoded by LUT	correct	P / F	P	-	P	P	
Doppler Location results with error \leq 5km	\geq 80	%	100	-	95	100	
15. Antenna Characteristics (Recalculation Only)						Result: Pass	
Test Configuration	As per C/S T.007		Configuration				Note: results by calculation only. Raw measurement data taken from TUV report 75924802 Report 01.
			1	2	3	4	
Polarisation	linear or RHCP		-	-	-	Linear	
VSWR	\leq 1.5		-	-	-	n/a	Detachable Antennas Only
EIRP _{LOSS}		dB	-	-	-	-1.27	
EIRP _{maxEOL}	\leq 43	dBm	-	-	-	40.6	
EIRP _{minEOL}	\geq 32	dBm	-	-	-	32.8	EIRP _{minEOL} limit decreases to 30 dBm for Configuration 4
15. Antenna Characteristics (Recalculation Only)						Result: Pass	
Test Configuration	As per C/S T.007		Configuration				Note: results by calculation only. Raw measurement data taken from TUV report 75924802 Report 01.
			1	2	3	4	
Polarisation	linear or RHCP		Linear	-	-	Linear	
VSWR	\leq 1.5		n/a	-	-	n/a	Detachable Antennas Only
EIRP _{LOSS}		dB	-1.27	-	-	-1.27	
EIRP _{maxEOL}	\leq 43	dBm	42.6	-	-	41.6	
EIRP _{minEOL}	\geq 32	dBm	32.1	-	-	33.0	EIRP _{minEOL} limit decreases to 30 dBm for Configuration 4
16. Beacon Coding Software						Result: Pass	
Sample message for each coding option of the applicable coding types	correct	P / F	P				
Sample self-test message for each coding option of the applicable coding types	correct	P / F	P				Applicant's data, see Annex A for details



Parameters to be Measured	Range of Specification	Units	Test Results			Comments
17. Navigation System						Result: Pass
Model: Tron 40VDR, S/N: 11975, TUV Ref: TSR1 and Modification State 0						
Location protocol	C/S T.001		National	Standard	User	No External navigation input.
Position data default values	correct	P / F	-	P	-	
Configuration 5						
Position accuracy - A.3.8.2.1	C/S T.001	m	-	35.6	-	
Position Acquisition Time - A.3.8.2.1	<10/1	min	-	0.95	-	
Position accuracy - A.3.8.2.2	C/S T.001	m	-	55.2	-	
Position Acquisition Time - A.3.8.2.2	<10/1	min	-	1.0	-	
Configuration 7						
Position accuracy - A.3.8.2.1	C/S T.001	m	-	35.6	-	
Position Acquisition Time - A.3.8.2.1	<10/1	min	-	0.98	-	
Position accuracy - A.3.8.2.2	C/S T.001	m	-	24.2	-	
Position Acquisition Time - A.3.8.2.2	<10/1	min	-	0.95	-	
Configuration 8 (Standalone)						
Position accuracy - A.3.8.2.1	C/S T.001	m	-	35.6	-	
Position Acquisition Time - A.3.8.2.1	<10/1	min	-	0.95	-	
Position accuracy - A.3.8.2.2	C/S T.001	m	-	24.2	-	
Position Acquisition Time - A.3.8.2.2	<10/1	min	-	0.96	-	
Encoded position data update interval	>5	min	-	6.66	-	
Position clearance after deactivation	cleared	P / F	-	P	-	
Position data input update interval (as applicable)	20/1	Min	-	N/A	-	
Configuration 8 (In Float Fee Case)						
Position accuracy - A.3.8.2.1	C/S T.001	m	-	35.6	-	
Position Acquisition Time - A.3.8.2.1	<10/1	min	-	0.98	-	
Position accuracy - A.3.8.2.2	C/S T.001	m	-	24.2	-	
Position Acquisition Time - A.3.8.2.2	<10/1	min	-	0.98	-	
Position data encoding	correct	P / F	-	P	-	See manufacturer supplied information – Annex A
Retained last valid position after navigation input lost	240(±5)	min	-	240.22	-	
Default position data transmitted after 240(±5) minutes without valid position data	cleared	P / F	-	P	-	
Information on protection against beacon degradation due to navigation device, interface or signal failure or malfunction	provided	Y / N	Y			See manufacturer supplied information – Annex A



2.1 POWER OUTPUT

2.1.1 Specification

Cospas-Sarsat T.007, Clause A.2.1 (a)

2.1.2 Equipment Under Test and Modification State

Tron 40VDR S/N: 11979 - Modification State 0

2.1.3 Date of Test

31 January 2018, 21 & 23 May 2018

2.1.4 Test Equipment Used

The major items of test equipment used for the above tests are identified in Section 3.1.

2.1.5 Environmental Conditions

Ambient Temperature 21.4 - 22.4°C

Relative Humidity 39.4 - 42.2%



2.1.6 Test Results

Ambient Temperature

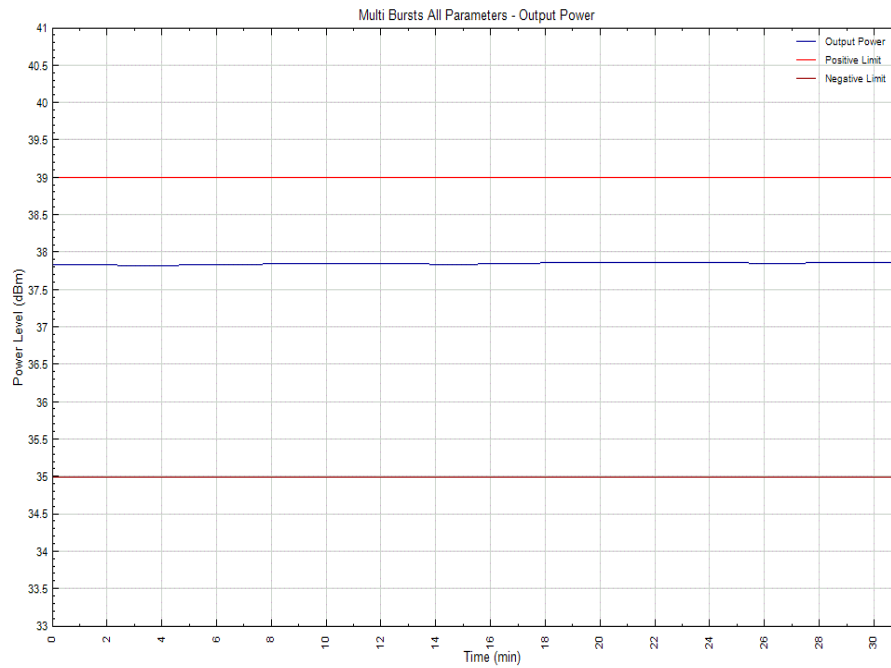

Low Temperature

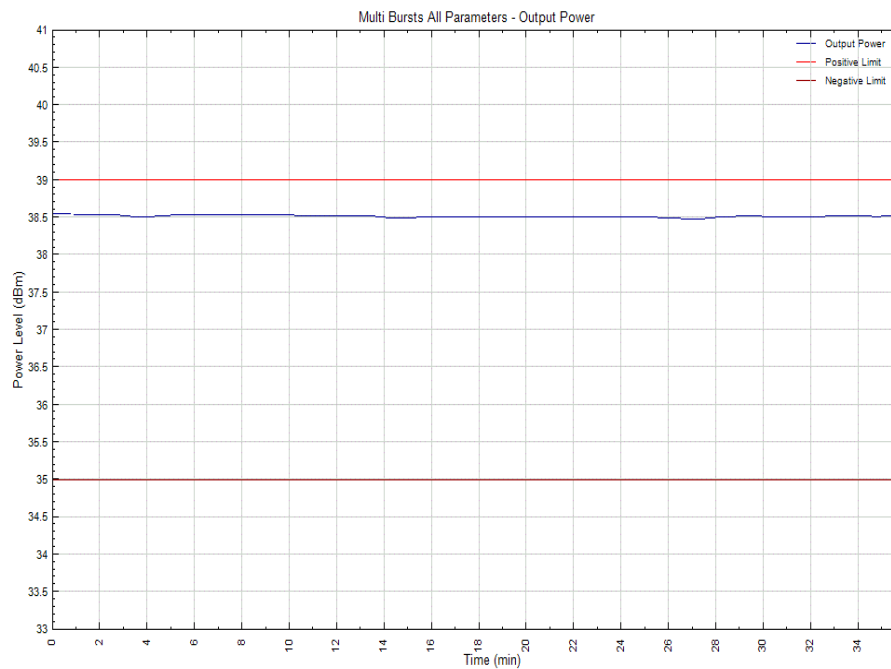



High Temperature

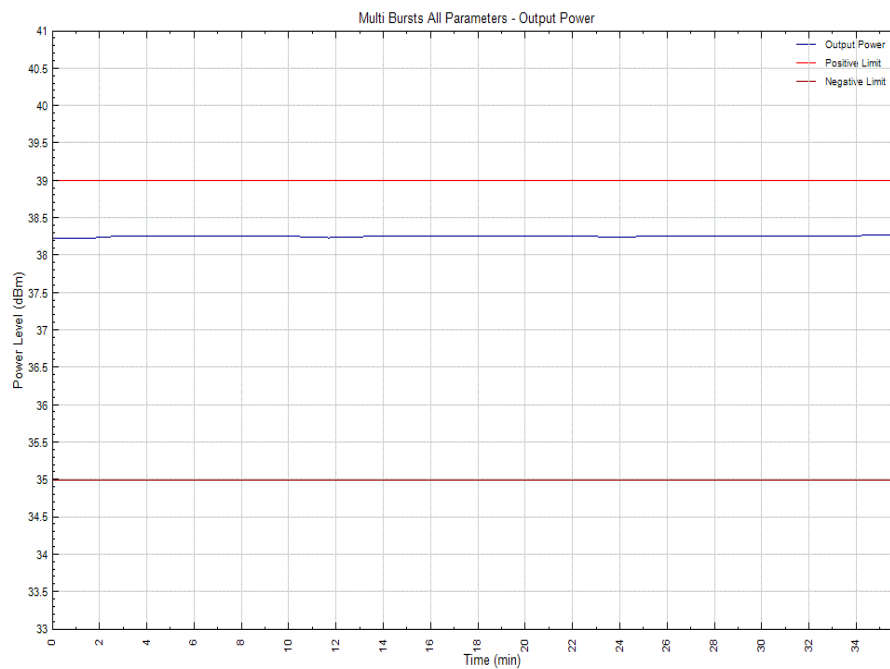

Summary

The EUT complies with clause A.3.2.2 of Cospas-Sarsat T.007.



2.2 DIGITAL MESSAGE

2.2.1 Specification

Cospas-Sarsat T.007, Clause A.2.1 (b)

2.2.2 Equipment Under Test and Modification State

Tron 40VDR S/N: 11979 - Modification State 0

2.2.3 Date of Test

31 January 2018, 21 & 23 May 2018

2.2.4 Test Equipment Used

The major items of test equipment used for the above tests are identified in Section 3.1.

2.2.5 Environmental Conditions

Ambient Temperature 21.4 - 22.4°C

Relative Humidity 39.4 - 42.2%



2.2.6 Test Results

Test Duration: 30 minutes

No. of bursts: 38

Ambient Temperature

Message	FFFE2F901E2E6EC77FDF9A957B783E0F66C		
Hex ID	203C5CDD8EFFBFF		
Position	None - Default Values		
Parameter	Bit	Data Bits	Decoded Value
Bit synchronization	1-15	1111111111111111	1111111111111111
Frame synchronization	16-24	000101111	000101111
Format Flag	25	1	1
Protocol Flag	26	0	0
Country Code	27-36	0100000001	Norway
Protocol Code	37-40	1110	Standard Test Location Protocol
Undefined	41-64	001011100110111011000111	001011100110111011000111
N/S	65	0	Default
Latitude Degrees	66-72	1111111	Default
Latitude Minutes	73-74	11	Default
E/W	75	0	Default
Longitude Degrees	76-83	11111111	Default
Longitude Minutes	84-85	11	Default
BCH Code (21 Bit)	86-106	00110101001010101110	00110101001010101110
Calculated BCH Code (21 Bit)	-	00110101001010101110	00110101001010101110
Supplementary Data Fixed	107-110	1101	1101
Encoded Position Data Source	111	1	Internal
121.5 MHz Homing	112	1	Yes
Delta Latitude +/-	113	1	Default
Delta Latitude Minutes	114-118	00000	Default
Delta Latitude Seconds	119-122	1111	Default
Delta Longitude +/-	123	1	Default
Delta Longitude Minutes	124-128	00000	Default
Delta Longitude Seconds	129-132	1111	Default
BCH Code (12 Bit)	133-144	011001101100	011001101100
Calculated BCH Code (12 Bit)	-	011001101100	011001101100



Low Temperature

Message	FFFE2F901E2E6ECB7FDFFAD8BEF783E0F66C		
Hex ID	203C5CDD96FFBFF		
Position	None - Default Values		
Parameter	Bit	Data Bits	Decoded Value
Bit synchronization	1-15	1111111111111111	1111111111111111
Frame synchronization	16-24	000101111	000101111
Format Flag	25	1	1
Protocol Flag	26	0	0
Country Code	27-36	0100000001	Norway
Protocol Code	37-40	1110	Standard Test Location Protocol
Undefined	41-64	001011100110111011001011	001011100110111011001011
N/S	65	0	Default
Latitude Degrees	66-72	11111111	Default
Latitude Minutes	73-74	11	Default
E/W	75	0	Default
Longitude Degrees	76-83	11111111	Default
Longitude Minutes	84-85	11	Default
BCH Code (21 Bit)	86-106	010110110001011111011	010110110001011111011
Calculated BCH Code (21 Bit)	-	010110110001011111011	010110110001011111011
Supplementary Data Fixed	107-110	1101	1101
Encoded Position Data Source	111	1	Internal
121.5 MHz Homing	112	1	Yes
Delta Latitude +/-	113	1	Default
Delta Latitude Minutes	114-118	00000	Default
Delta Latitude Seconds	119-122	1111	Default
Delta Longitude +/-	123	1	Default
Delta Longitude Minutes	124-128	00000	Default
Delta Longitude Seconds	129-132	1111	Default
BCH Code (12 Bit)	133-144	011001101100	011001101100
Calculated BCH Code (12 Bit)	-	011001101100	011001101100



High Temperature

Message	FFFE2F901E2E6ECB7FDFFAD8BEF783E0F66C		
Hex ID	203C5CDD96FFBFF		
Position	None - Default Values		
Parameter	Bit	Data Bits	Decoded Value
Bit synchronization	1-15	1111111111111111	1111111111111111
Frame synchronization	16-24	000101111	000101111
Format Flag	25	1	1
Protocol Flag	26	0	0
Country Code	27-36	0100000001	Norway
Protocol Code	37-40	1110	Standard Test Location Protocol
Undefined	41-64	001011100110111011001011	001011100110111011001011
N/S	65	0	Default
Latitude Degrees	66-72	11111111	Default
Latitude Minutes	73-74	11	Default
E/W	75	0	Default
Longitude Degrees	76-83	11111111	Default
Longitude Minutes	84-85	11	Default
BCH Code (21 Bit)	86-106	010110110001011111011	010110110001011111011
Calculated BCH Code (21 Bit)	-	010110110001011111011	010110110001011111011
Supplementary Data Fixed	107-110	1101	1101
Encoded Position Data Source	111	1	Internal
121.5 MHz Homing	112	1	Yes
Delta Latitude +/-	113	1	Default
Delta Latitude Minutes	114-118	00000	Default
Delta Latitude Seconds	119-122	1111	Default
Delta Longitude +/-	123	1	Default
Delta Longitude Minutes	124-128	00000	Default
Delta Longitude Seconds	129-132	1111	Default
BCH Code (12 Bit)	133-144	011001101100	011001101100
Calculated BCH Code (12 Bit)	-	011001101100	011001101100

Summary

The EUT complies with clause A.3.1.4 of Cospas-Sarsat T.007.



2.3 MODULATION

2.3.1 Specification

Cospas-Sarsat T.007, Clause A.2.1 (d)

2.3.2 Equipment Under Test and Modification State

Tron 40VDR S/N: 11979 - Modification State 0

2.3.3 Date of Test

31 January 2018, 21 & 23 May 2018

2.3.4 Test Equipment Used

The major items of test equipment used for the above tests are identified in Section 3.1.

2.3.5 Environmental Conditions

Ambient Temperature 21.4 - 22.4°C

Relative Humidity 39.4 - 42.2%



2.3.6 Test Results

Test Duration: 30 minutes
No. of bursts: 38

Ambient Temperature

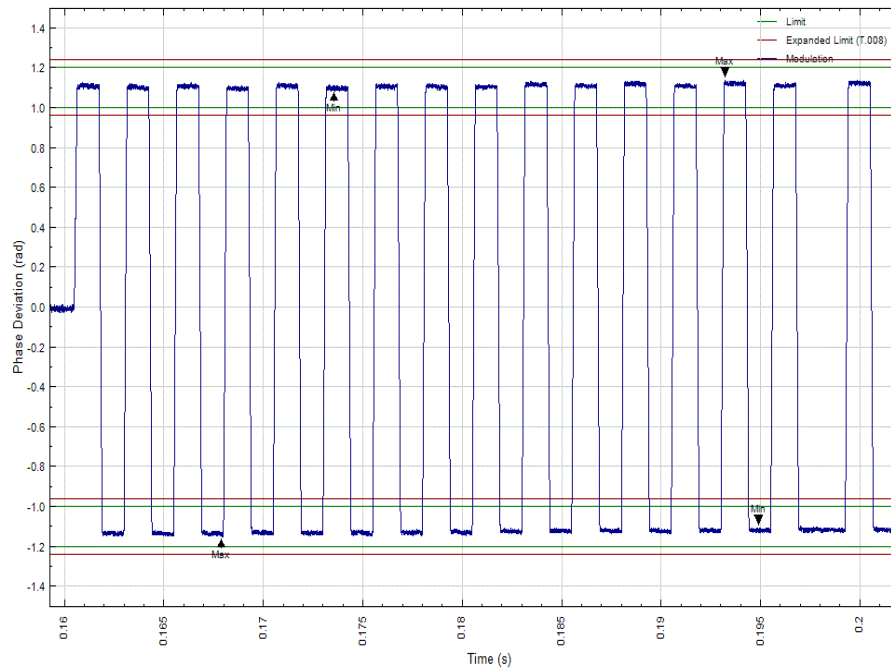

Low Temperature

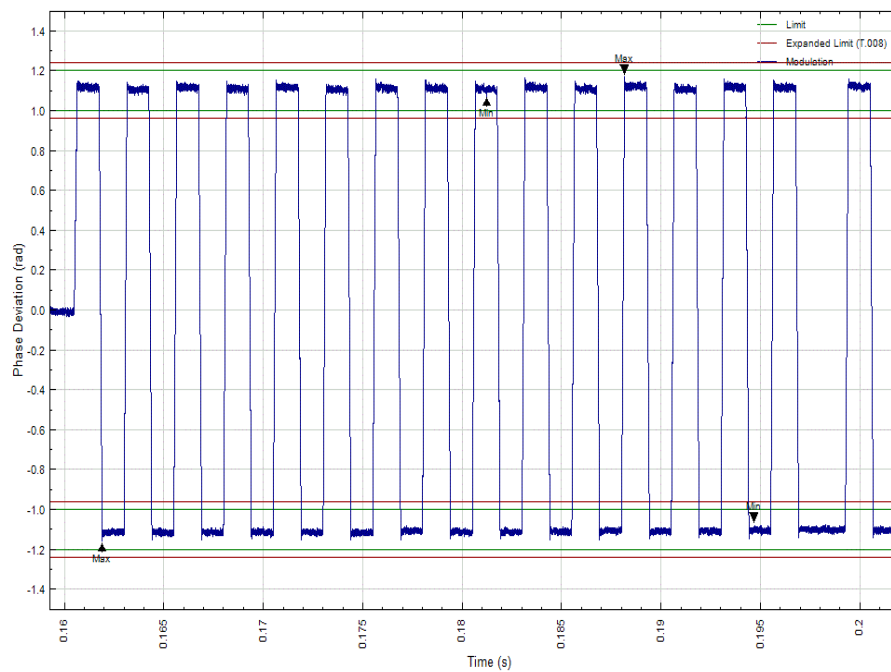

High Temperature

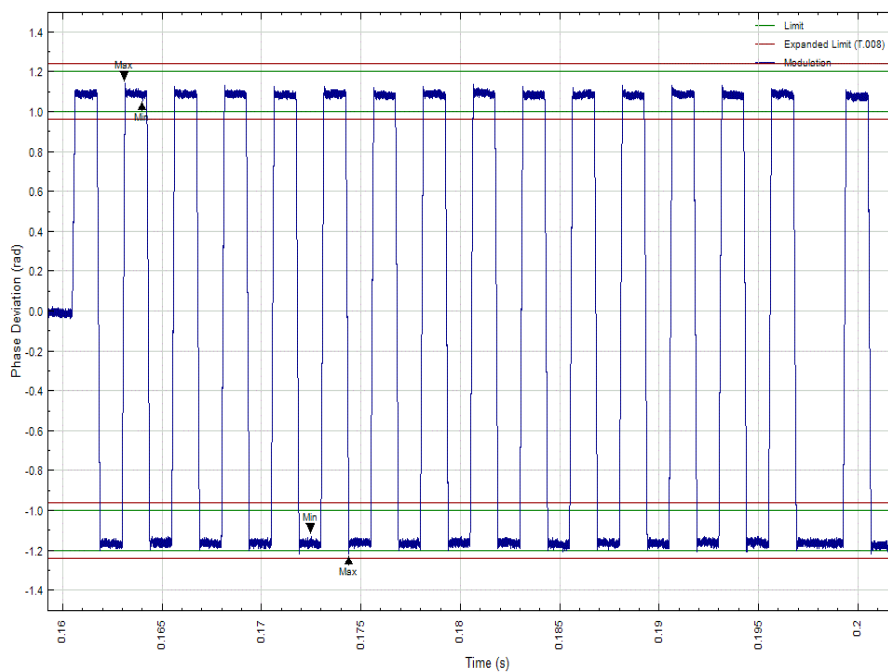

Summary

The EUT fails to comply* with clause A.3.3 of Cospas-Sarsat T.007.

* Results exceeds the limits of C/S T.007. However, the result is within the Test Facility accuracy stated in C/S T.008.



2.4 406 MHZ TRANSMITTED FREQUENCY

2.4.1 Specification

Cospas-Sarsat T.007, Clause A.2.1 (e)

2.4.2 Equipment Under Test and Modification State

Tron 40VDR S/N: 11979 - Modification State 0

2.4.3 Date of Test

31 January 2018

2.4.4 Test Equipment Used

The major items of test equipment used for the above tests are identified in Section 3.1.

2.4.5 Environmental Conditions

Ambient Temperature 22.2°C

Relative Humidity 42.2%

2.4.6 Test Results

Ambient Temperature

Nominal Frequency

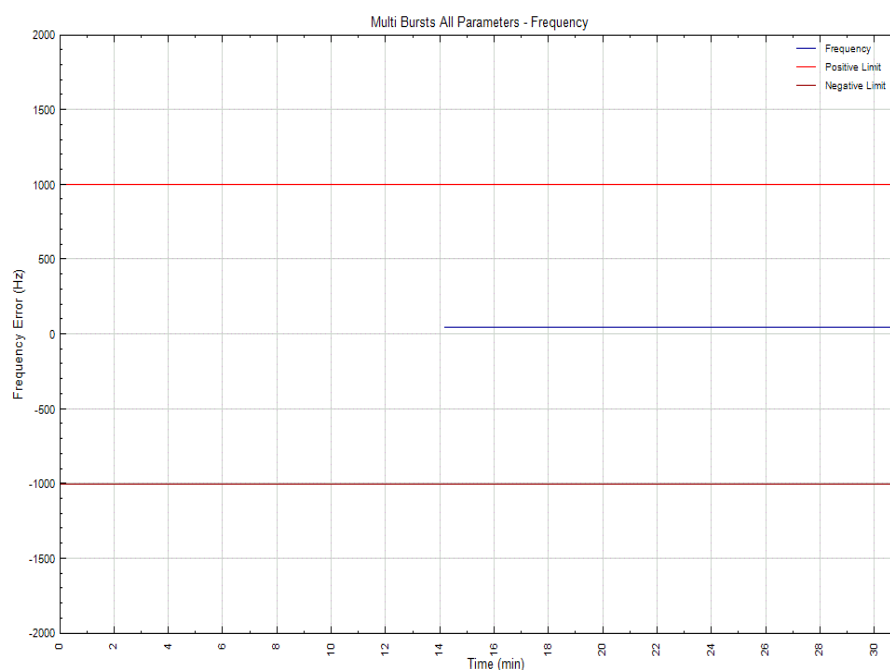



Short Term Stability

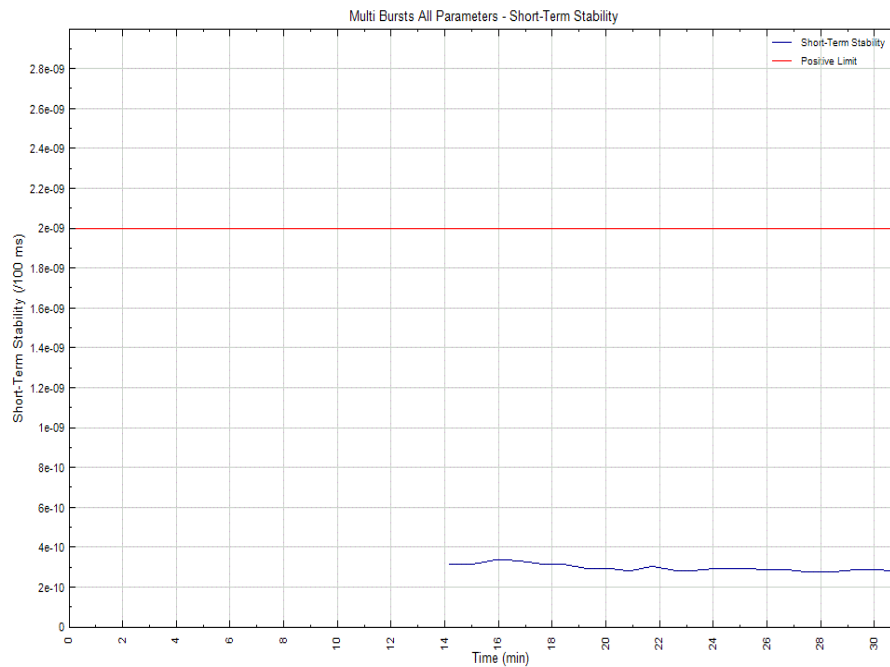

Medium Term Stability – Slope

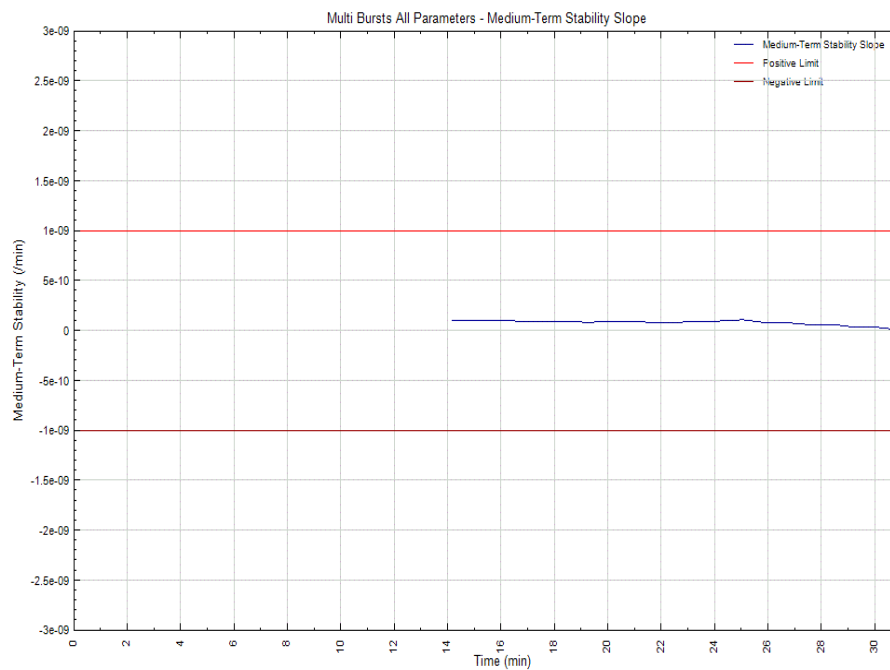



Medium Term Stability – Residual

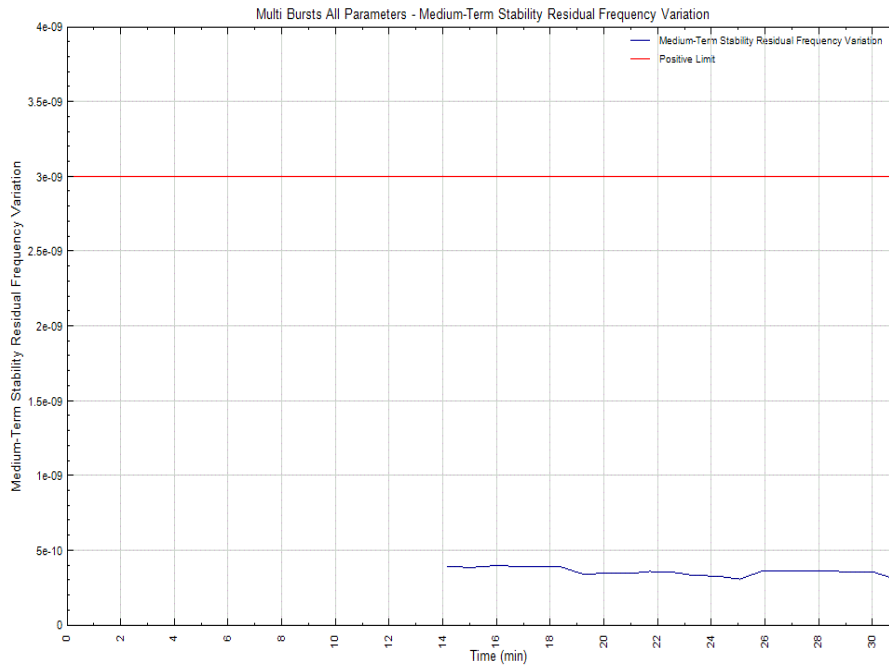

Low Temperature

Nominal Frequency

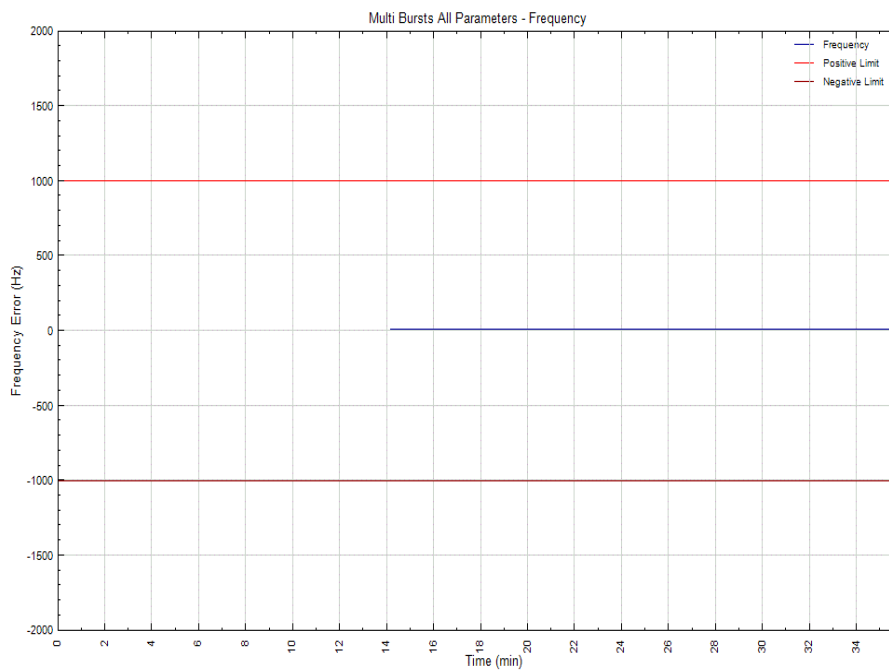



Short Term Stability

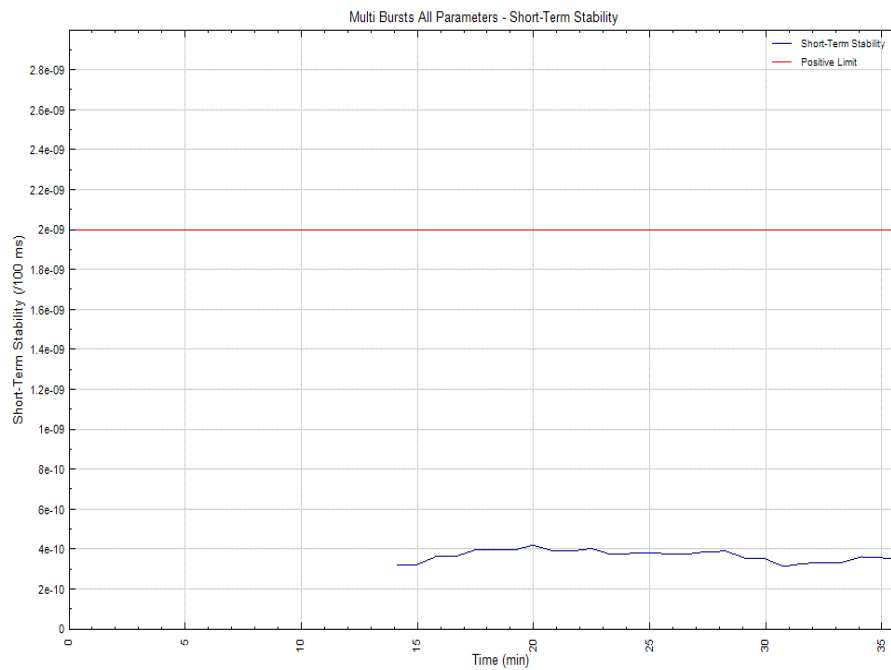

Medium Term Stability – Slope

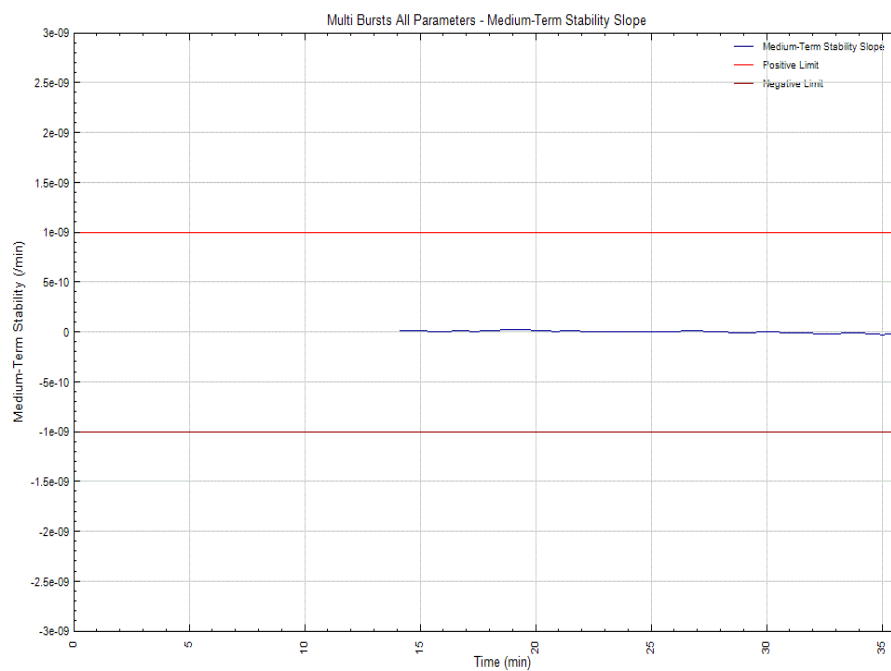



Medium Term Stability – Residual

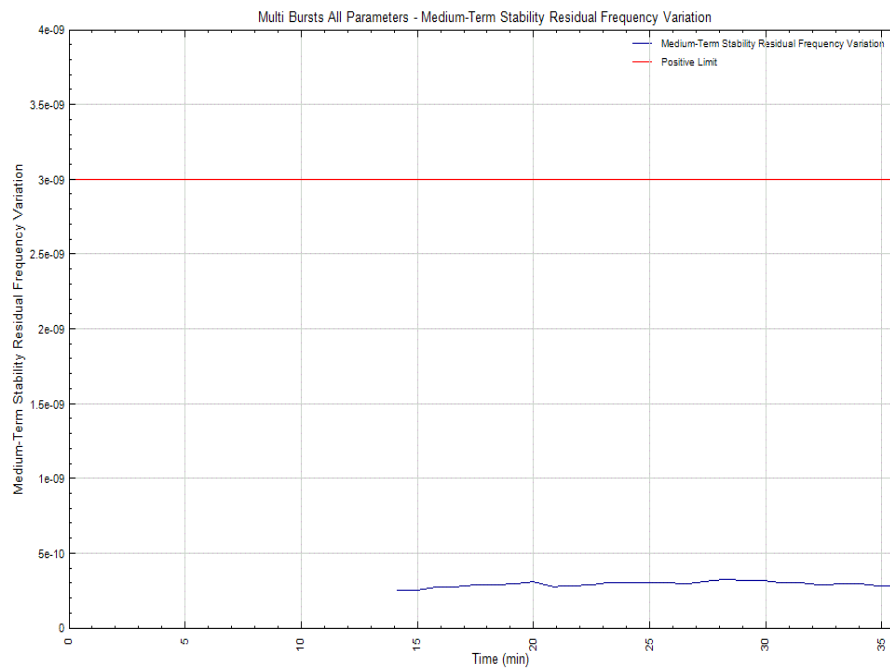

High Temperature

Nominal Frequency

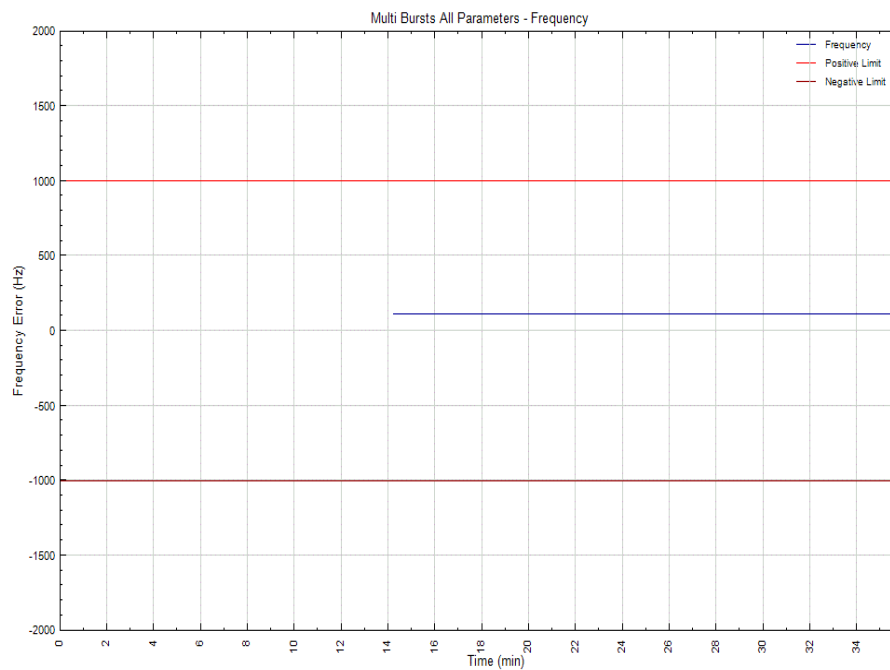



Short Term Stability

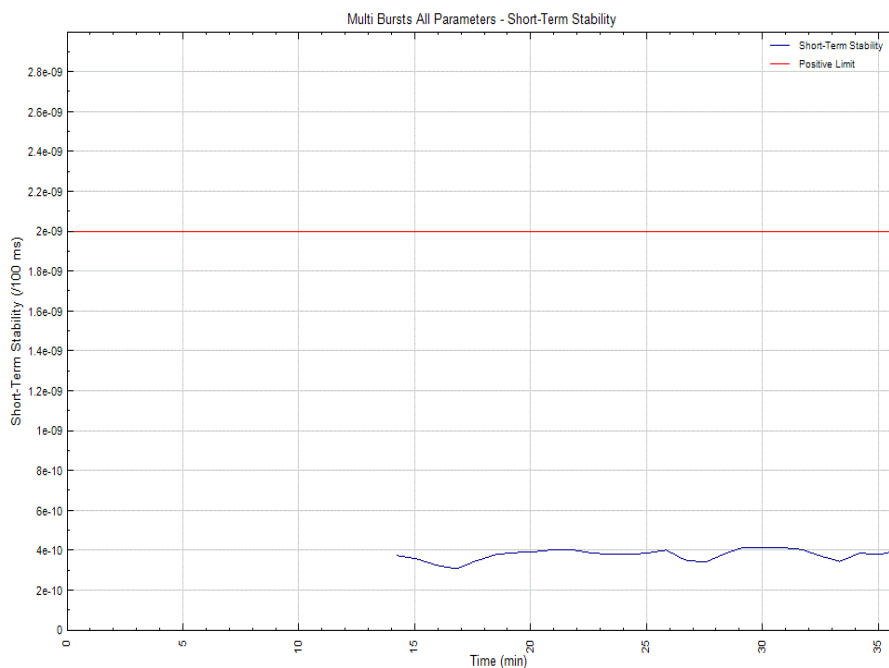

Medium Term Stability – Slope

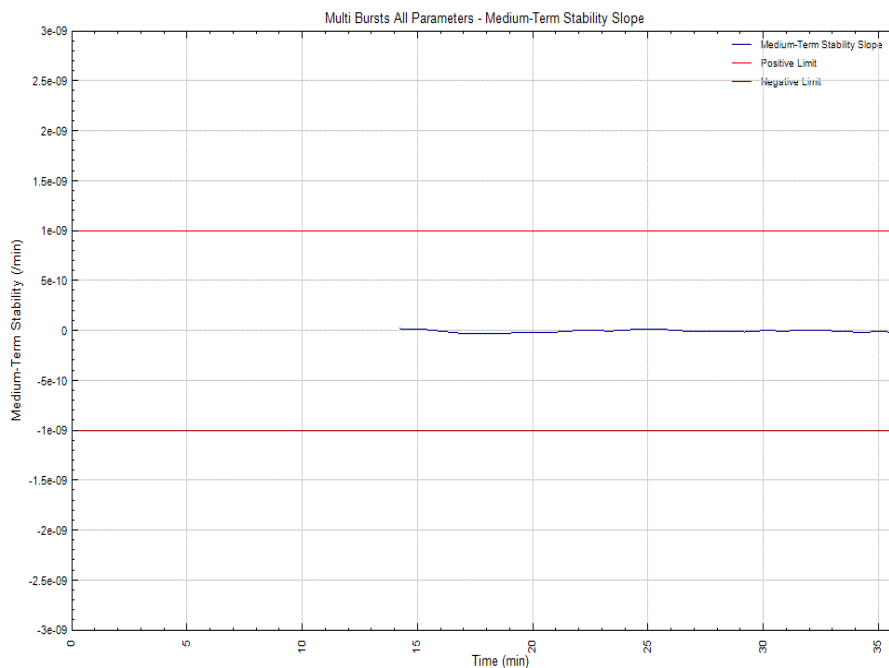



Medium Term Stability – Residual

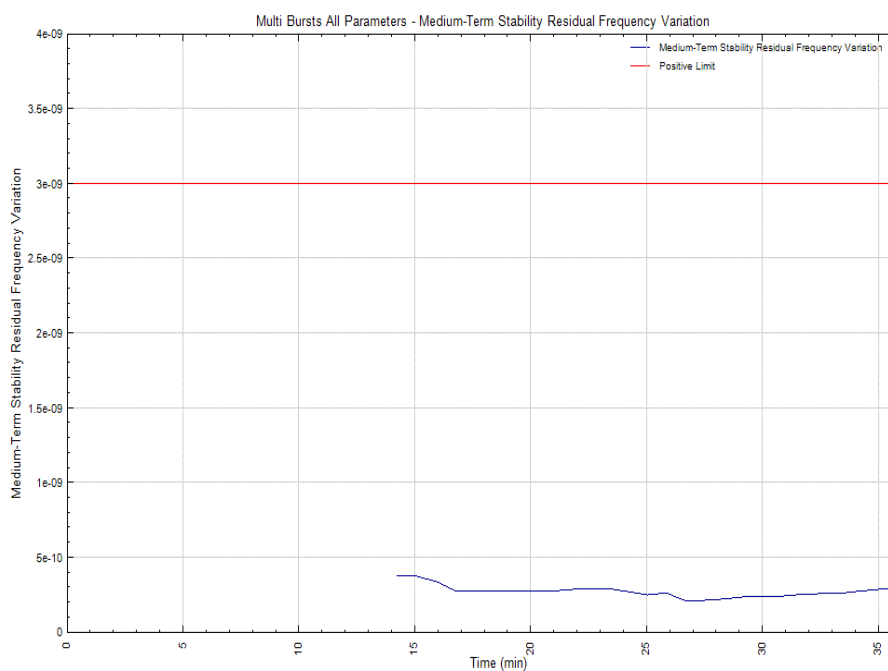

Summary

The EUT complies with clause A.3.2.1 of Cospas-Sarsat T.007.



2.5 SPURIOUS EMISSION INTO 50 OHMS

2.5.1 Specification

Cospas-Sarsat T.007, Clause A.2.1 (f)

2.5.2 Equipment Under Test and Modification State

Tron 40VDR S/N: 11979 - Modification State 0

2.5.3 Date of Test

02 February 2018, 25 & 29 May 2018

2.5.4 Test Equipment Used

The major items of test equipment used for the above tests are identified in Section 3.1.

2.5.5 Environmental Conditions

Ambient Temperature 22.8 - 23.1°C

Relative Humidity 39.5 – 41.8%



2.5.6 Test Results

Test Duration: 1260 minutes

Ambient Temperature

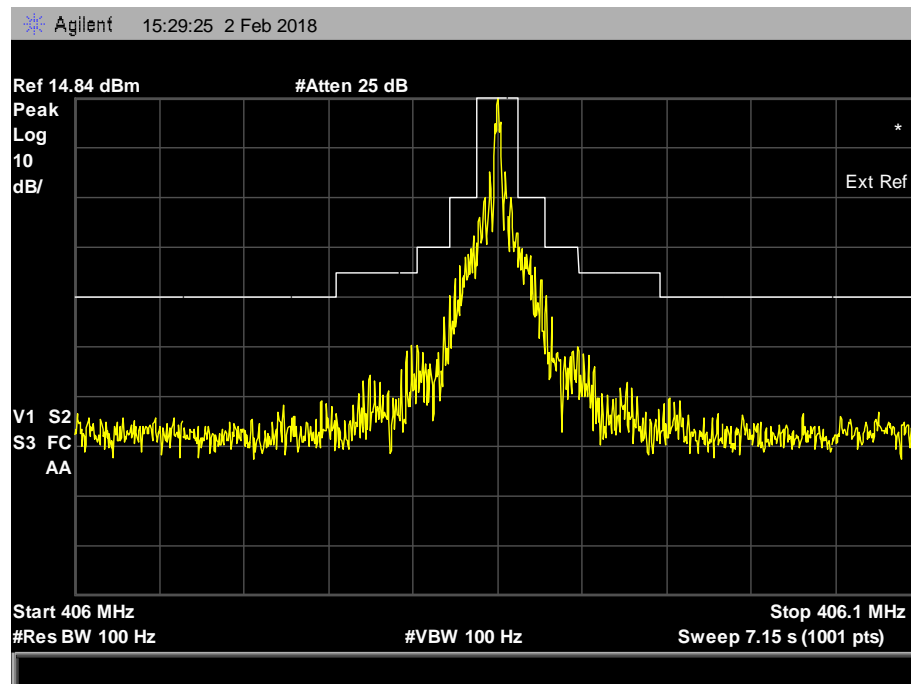

Low Temperature

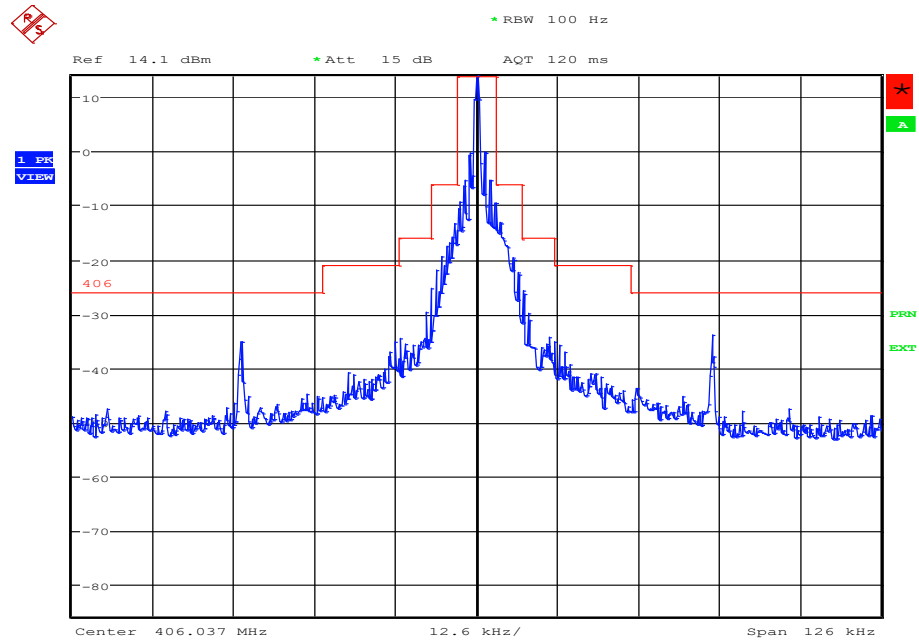

High Temperature

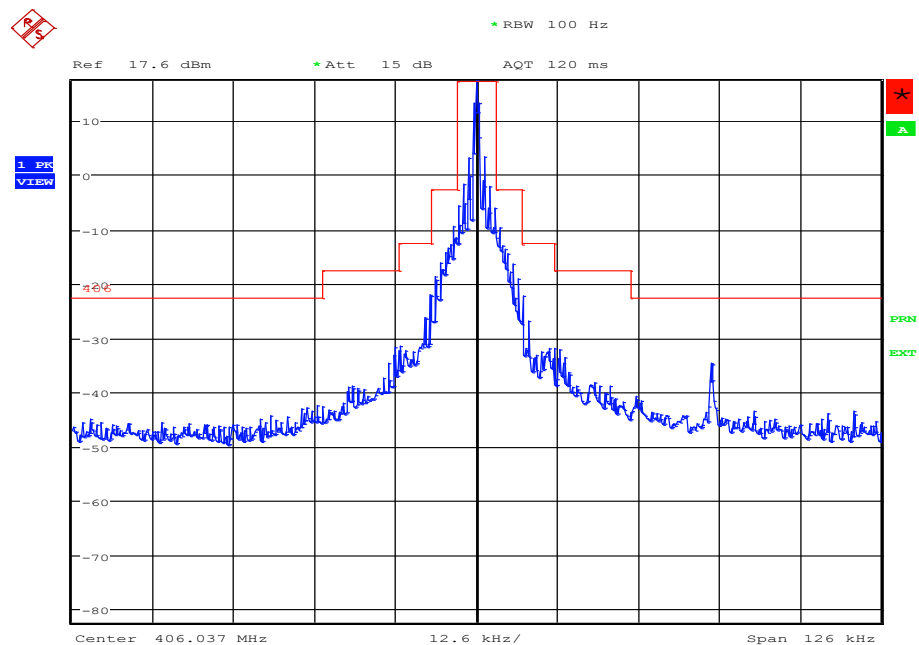

Summary

The EUT complies with clause A.3.2.2.4 of Cospas-Sarsat T.007.



2.6 406 MHZ VSWR CHECK

2.6.1 Specification

Cospas-Sarsat T.007, Clause A.2.1 (g)

2.6.2 Equipment Under Test and Modification State

Tron 40VDR S/N: 11979 - Modification State 0

2.6.3 Date of Test

16 March 2018, 22 & 24 May 2018

2.6.4 Test Equipment Used

The major items of test equipment used for the above tests are identified in Section 3.1.

2.6.5 Environmental Conditions

Ambient Temperature 20.2 - 21.1°C

Relative Humidity 42.3 – 51.1%



2.6.6 Test Results

Test Duration: 30 minutes

No. of bursts: 38

Ambient Temperature

Message	FFFE2F901E2E6ECB7FDFFAD8BEF783E0F66C		
Hex ID	203C5CDD96FFBFF		
Position	None - Default Values		
Parameter	Bit	Data Bits	Decoded Value
Bit synchronization	1-15	111111111111111	111111111111111
Frame synchronization	16-24	000101111	000101111
Format Flag	25	1	1
Protocol Flag	26	0	0
Country Code	27-36	010000001	Norway
Protocol Code	37-40	1110	Standard Test Location Protocol
Undefined	41-64	001011100110111011001011	001011100110111011001011
N/S	65	0	Default
Latitude Degrees	66-72	1111111	Default
Latitude Minutes	73-74	11	Default
E/W	75	0	Default
Longitude Degrees	76-83	11111111	Default
Longitude Minutes	84-85	11	Default
BCH Code (21 Bit)	86-106	01011011000101111011	01011011000101111011
Calculated BCH Code (21 Bit)	-	01011011000101111011	01011011000101111011
Supplementary Data Fixed	107-110	1101	1101
Encoded Position Data Source	111	1	Internal
121.5 MHz Homing	112	1	Yes
Delta Latitude +/-	113	1	Default
Delta Latitude Minutes	114-118	00000	Default
Delta Latitude Seconds	119-122	1111	Default
Delta Longitude +/-	123	1	Default
Delta Longitude Minutes	124-128	00000	Default
Delta Longitude Seconds	129-132	1111	Default
BCH Code (12 Bit)	133-144	011001101100	011001101100
Calculated BCH Code (12 Bit)	-	011001101100	011001101100

Frequency Plot

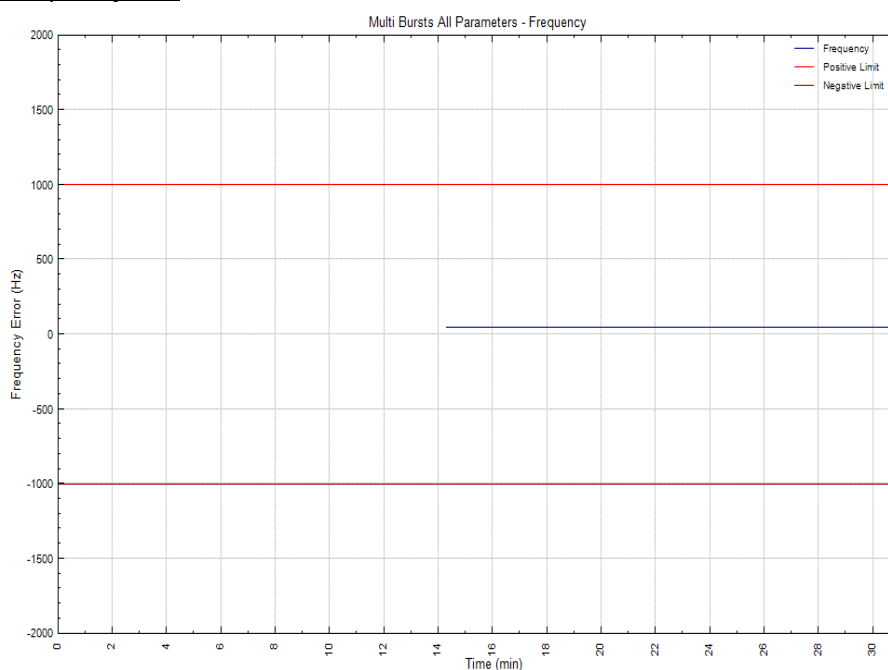



Modulation Plot

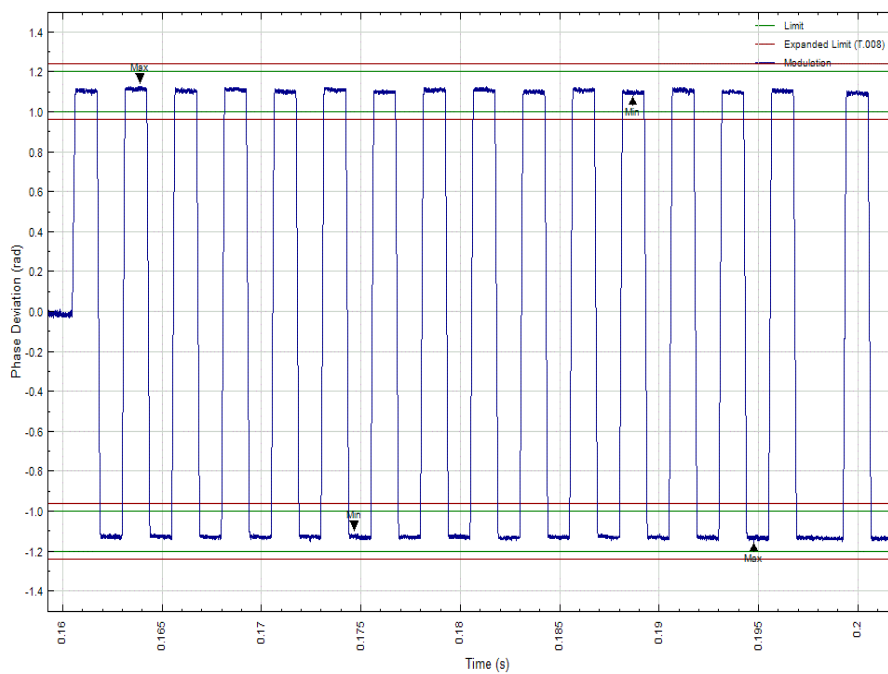

Low Temperature

Message	FFFE2F901E2E6ECB7FDFFAD8BEF783E0F66C		
Hex ID	203C5CDD96FFBFF		
Position	None - Default Values		
Parameter	Bit	Data Bits	Decoded Value
Bit synchronization	1-15	111111111111111	111111111111111
Frame synchronization	16-24	000101111	000101111
Format Flag	25	1	1
Protocol Flag	26	0	0
Country Code	27-36	0100000001	Norway
Protocol Code	37-40	1110	Standard Test Location Protocol
Undefined	41-64	001011100110111011001011	001011100110111011001011
N/S	65	0	Default
Latitude Degrees	66-72	1111111	Default
Latitude Minutes	73-74	11	Default
E/W	75	0	Default
Longitude Degrees	76-83	11111111	Default
Longitude Minutes	84-85	11	Default
BCH Code (21 Bit)	86-106	01011011000101111011	01011011000101111011
Calculated BCH Code (21 Bit)	-	01011011000101111011	01011011000101111011
Supplementary Data Fixed	107-110	1101	1101
Encoded Position Data Source	111	1	Internal
121.5 MHz Homing	112	1	Yes
Delta Latitude +/-	113	1	Default
Delta Latitude Minutes	114-118	00000	Default
Delta Latitude Seconds	119-122	1111	Default
Delta Longitude +/-	123	1	Default
Delta Longitude Minutes	124-128	00000	Default
Delta Longitude Seconds	129-132	1111	Default
BCH Code (12 Bit)	133-144	011001101100	011001101100
Calculated BCH Code (12 Bit)	-	011001101100	011001101100

Frequency Plot

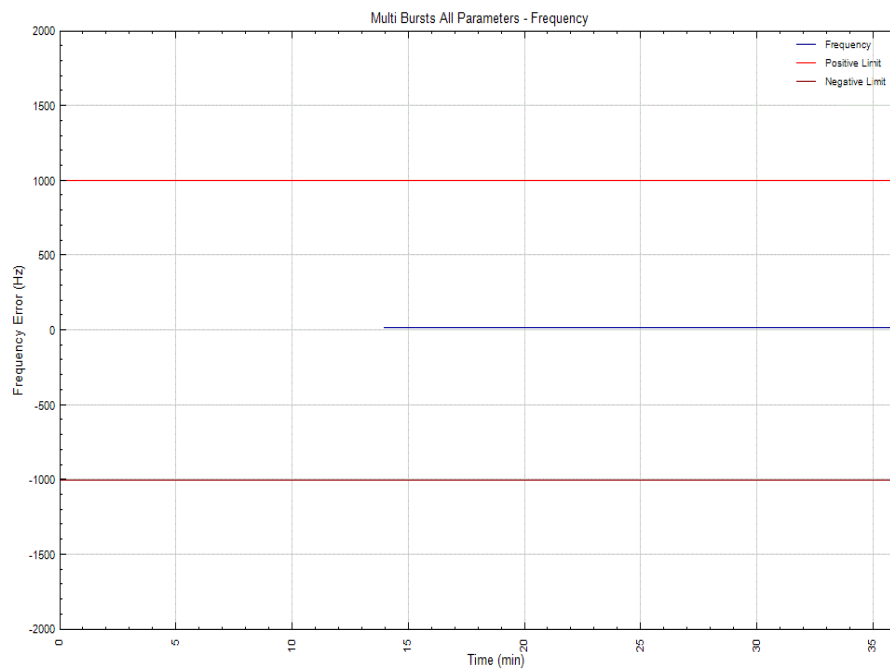

Modulation Plot

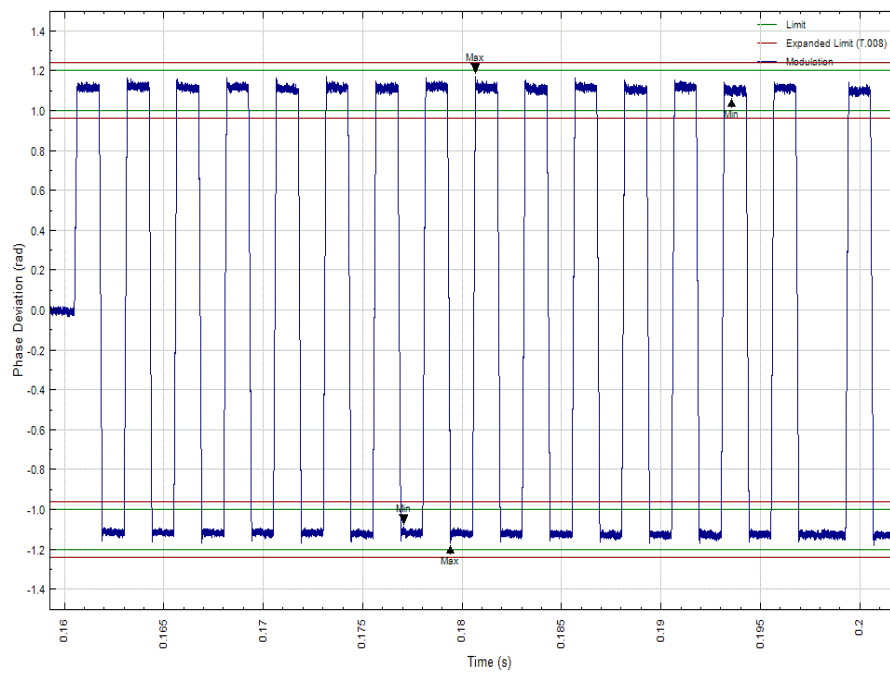



High Temperature

Message	FFFE2F901E2E6ECB7FDFFAD8BEF783E0F66C		
Hex ID	203C5CDD96FFBFF		
Position	None - Default Values		
Parameter	Bit	Data Bits	Decoded Value
Bit synchronization	1-15	111111111111111	111111111111111
Frame synchronization	16-24	000101111	000101111
Format Flag	25	1	1
Protocol Flag	26	0	0
Country Code	27-36	0100000001	Norway
Protocol Code	37-40	1110	Standard Test Location Protocol
Undefined	41-64	001011100110111011001011	001011100110111011001011
N/S	65	0	Default
Latitude Degrees	66-72	1111111	Default
Latitude Minutes	73-74	11	Default
E/W	75	0	Default
Longitude Degrees	76-83	11111111	Default
Longitude Minutes	84-85	11	Default
BCH Code (21 Bit)	86-106	010110110001011111011	010110110001011111011
Calculated BCH Code (21 Bit)	-	010110110001011111011	010110110001011111011
Supplementary Data Fixed	107-110	1101	1101
Encoded Position Data Source	111	1	Internal
121.5 MHz Homing	112	1	Yes
Delta Latitude +/-	113	1	Default
Delta Latitude Minutes	114-118	00000	Default
Delta Latitude Seconds	119-122	1111	Default
Delta Longitude +/-	123	1	Default
Delta Longitude Minutes	124-128	00000	Default
Delta Longitude Seconds	129-132	1111	Default
BCH Code (12 Bit)	133-144	011001101100	011001101100
Calculated BCH Code (12 Bit)	-	011001101100	011001101100

Frequency Plot

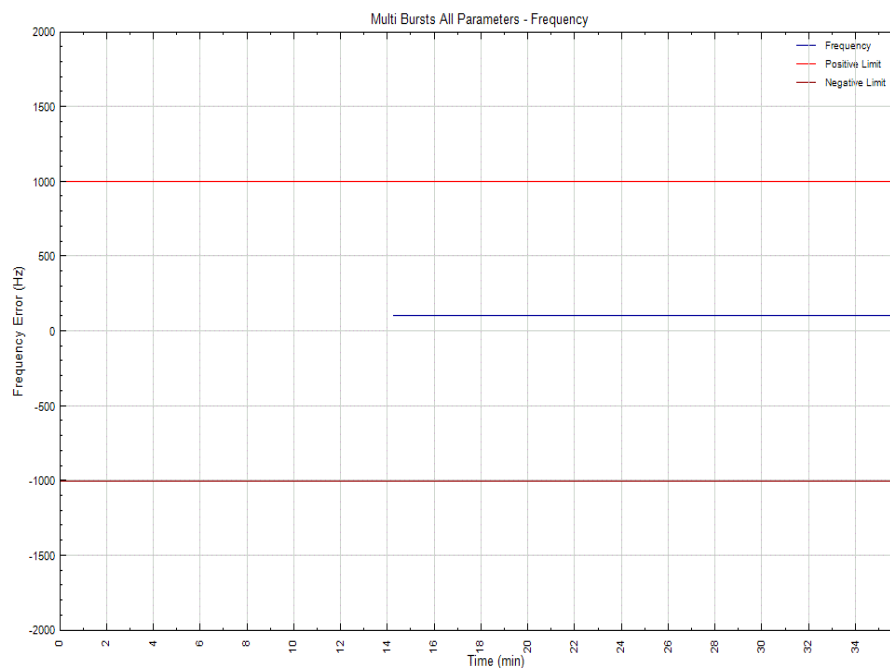

Modulation Plot

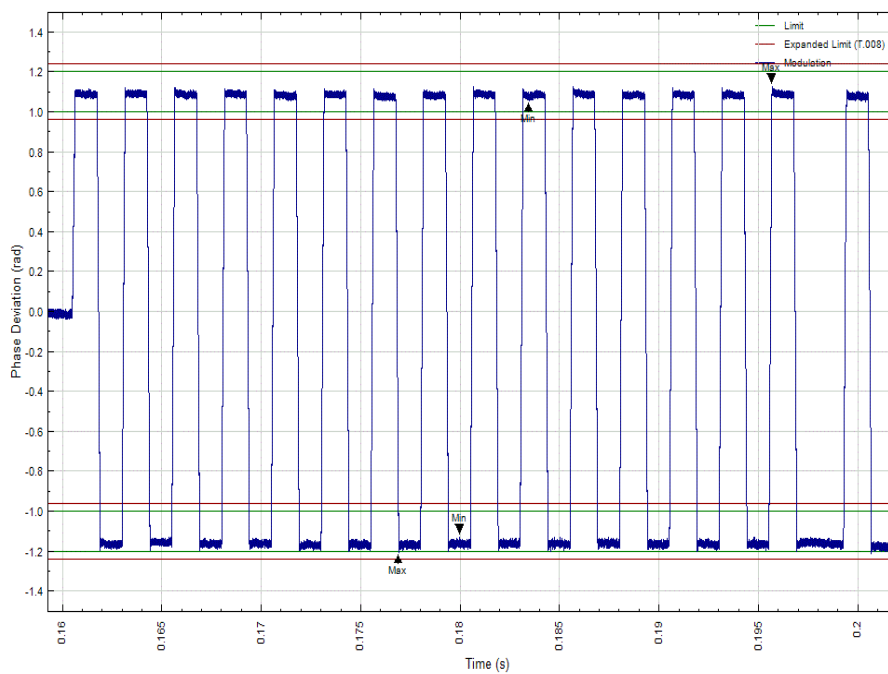

Summary

The EUT fails to comply* with clause A.3.3 of Cospas-Sarsat T.007.

* Results exceeds the limits of C/S T.007. However, the result is within the Test Facility accuracy stated in C/S T.008.



2.7 SELF-TEST MODES

2.7.1 Specification

Cospas-Sarsat T.007, Clause A.2.1 (h)

2.7.2 Equipment Under Test and Modification State

Tron 40VDR S/N: 11979 - Modification State 1

2.7.3 Date of Test

28 & 29 June 2018 & 02 July 2018

2.7.4 Test Equipment Used

The major items of test equipment used for the above tests are identified in Section 3.1.

2.7.5 Environmental Conditions

Ambient Temperature 23.9 – 25.2°C

Relative Humidity 40.3 – 42.7%



2.7.6 Test Results

Self-test Mode

Ambient Temperature

Message	FFED0901E2E6ECB7FDFFAD8BEF783E0F66C		
Hex ID	203C5CDD96FFBFF		
Position	None - Default Values		
Parameter	Bit	Data Bits	Decoded Value
Bit synchronization	1-15	111111111111111	111111111111111
Frame synchronization	16-24	011010000	011010000
Format Flag	25	1	1
Protocol Flag	26	0	0
Country Code	27-36	010000001	Norway
Protocol Code	37-40	1110	Standard Test Location Protocol
Undefined	41-64	001011100110111011001011	001011100110111011001011
N/S	65	0	Default
Latitude Degrees	66-72	1111111	Default
Latitude Minutes	73-74	11	Default
E/W	75	0	Default
Longitude Degrees	76-83	11111111	Default
Longitude Minutes	84-85	11	Default
BCH Code (21 Bit)	86-106	01011011000101111011	01011011000101111011
Calculated BCH Code (21 Bit)	-	01011011000101111011	01011011000101111011
Supplementary Data Fixed	107-110	1101	1101
Encoded Position Data Source	111	1	Internal
121.5 MHz Homing	112	1	Yes
Delta Latitude +/-	113	1	Default
Delta Latitude Minutes	114-118	00000	Default
Delta Latitude Seconds	119-122	1111	Default
Delta Longitude +/-	123	1	Default
Delta Longitude Minutes	124-128	00000	Default
Delta Longitude Seconds	129-132	1111	Default
BCH Code (12 Bit)	133-144	011001101100	011001101100
Calculated BCH Code (12 Bit)	-	011001101100	011001101100

Note: Self-test at ambient temperature carried out with navigation data applied.

Observation Comments

- A Self-Test is initiated by holding the slider switch in the TEST position for 10 seconds. There are no indications from the EUT during this time.
- After this time the slider switch is released.
- The EUT emits a single strobe light flash*, indicating a PASS result.

* Note: Performing a Self-Test on the modified 50ohm conducted sample, returned a double strobe light flash. The operator's manual indicates that this due to low power on the 406 MHz transmitter. The manufacturer has advised that this is an expected result, due to the nature of the RF output modification. The test was repeated on the fully packaged EUT submitted for type approval (S/N 11975) and resulted in a single strobe flash indicating a PASS result.



Low Temperature

Message	FF FED0901E2E6ECB7FDFFAD8BEF783E0F66C		
Hex ID	203C5CDD96FFBFF		
Position	None - Default Values		
Parameter	Bit	Data Bits	Decoded Value
Bit synchronization	1-15	1111111111111111	1111111111111111
Frame synchronization	16-24	011010000	011010000
Format Flag	25	1	1
Protocol Flag	26	0	0
Country Code	27-36	0100000001	Norway
Protocol Code	37-40	1110	Standard Test Location Protocol
Undefined	41-64	001011100110111011001011	001011100110111011001011
N/S	65	0	Default
Latitude Degrees	66-72	11111111	Default
Latitude Minutes	73-74	11	Default
E/W	75	0	Default
Longitude Degrees	76-83	11111111	Default
Longitude Minutes	84-85	11	Default
BCH Code (21 Bit)	86-106	010110110001011111011	010110110001011111011
Calculated BCH Code (21 Bit)	-	010110110001011111011	010110110001011111011
Supplementary Data Fixed	107-110	1101	1101
Encoded Position Data Source	111	1	Internal
121.5 MHz Homing	112	1	Yes
Delta Latitude +/-	113	1	Default
Delta Latitude Minutes	114-118	00000	Default
Delta Latitude Seconds	119-122	1111	Default
Delta Longitude +/-	123	1	Default
Delta Longitude Minutes	124-128	00000	Default
Delta Longitude Seconds	129-132	1111	Default
BCH Code (12 Bit)	133-144	011001101100	011001101100
Calculated BCH Code (12 Bit)	-	011001101100	011001101100

High Temperature

Message	FF FED0901E2E6ECB7FDFFAD8BEF783E0F66C		
Hex ID	203C5CDD96FFBFF		
Position	None - Default Values		
Parameter	Bit	Data Bits	Decoded Value
Bit synchronization	1-15	1111111111111111	1111111111111111
Frame synchronization	16-24	011010000	011010000
Format Flag	25	1	1
Protocol Flag	26	0	0
Country Code	27-36	0100000001	Norway
Protocol Code	37-40	1110	Standard Test Location Protocol
Undefined	41-64	001011100110111011001011	001011100110111011001011
N/S	65	0	Default
Latitude Degrees	66-72	11111111	Default
Latitude Minutes	73-74	11	Default
E/W	75	0	Default
Longitude Degrees	76-83	11111111	Default
Longitude Minutes	84-85	11	Default
BCH Code (21 Bit)	86-106	010110110001011111011	010110110001011111011
Calculated BCH Code (21 Bit)	-	010110110001011111011	010110110001011111011
Supplementary Data Fixed	107-110	1101	1101
Encoded Position Data Source	111	1	Internal
121.5 MHz Homing	112	1	Yes
Delta Latitude +/-	113	1	Default
Delta Latitude Minutes	114-118	00000	Default
Delta Latitude Seconds	119-122	1111	Default
Delta Longitude +/-	123	1	Default
Delta Longitude Minutes	124-128	00000	Default
Delta Longitude Seconds	129-132	1111	Default
BCH Code (12 Bit)	133-144	011001101100	011001101100
Calculated BCH Code (12 Bit)	-	011001101100	011001101100



Table F-E.3: Self-test Mode Actions and Indications

No.	Action/Indication	Time-stamp (HH:MM:SS)	Description of action/indication	Duration of action/indication (sec)	Notes
1	Self-Test mode initiation (distinct action)	00:00:00	Slide and hold main switch in TEST position	10 seconds	Switch released at step 6 (after strobe light visual indication)
2	Distinct indication of the Self-test initiation	-	No indication	-	
3	Self-test single burst transmission	00:00:09	Self-Test transmission	520mS	Verified by TUV test system
4	Self-test message default values	00:00:09	Transmission of default values	-	Verified by TUV test system
5	Distinct indication of RF transmission	-	No indication	-	
6	Distinct indication of the Self-test PASS result	00:00:10	Single strobe light flash	1 second	
7	Distinct indication of the Self-test FAIL result	00:00:10	Multiple strobe light flashes	1 second per flash	See manufacturer supplied information for 'Fail' strobe light flash sequence
8	Distinct indication of Insufficient Battery Energy	N/A	-	-	Not supported
9	Automatic termination of the Self-test mode, irrespectively of the switch position	-	-	-	See battery current measurements for further information
10	Duration of the Self-test mode	00:00:11	Visual indications cease	-	Time shown for Self-Test 'PASS'. Time will increase for multiple failing strobe indications. Note: Time indicated for visual observation. Battery current measurements show that the complete test time (until current returns to zero) is around 16 seconds.

GNSS Self-test mode

General

All duration measurements below include activation method time, i.e. they start from test switch press and include any "hold for x seconds" requirement and they end when all visual and audible activity appeared to cease.

All positional accuracy values below were calculated using the Haversine Formula; the Earth's radius was taken as 6367 km.



GNSS Self-Test Observations

Parameter	Actual	Declared
GNSS Self-test count	60	60
GNSS Self-test maximum duration (s) incl. activation method	125	130
Indication of GNSS Self-test activation/completion	<p>A GNSS self-test is activated by moving the main slider switch to the TEST position twice within three seconds. The EUT will then emit an audible tone once every four seconds until one of the following occurs:</p> <p>If navigation data is detected, a double audible tone followed by a double strobe flash will indicate the end of the test. A 406MHz message will be transmitted encoded with position data.</p> <p>If no navigation data is detected the EUT will emit 5 audible tones. The test will then terminate with no further activity.</p>	
Indication of GNSS Self-test count limit reached	The EUT will emit 10 audible tones in succession, followed by no further activity.	

Summary: GNSS Self-test with Valid Navigation Input

Protocol	Standard Location Protocol		
Temperature (°C)	-20	+22	+55
Frame sync verification	011010000	011010000	011010000
Format Flag (1 bit)	1	1	1
Single Radiated burst (ms)	519.914	519.932	519.913
Position data	P	P	P
Single burst verification	P	P	P
Actual duration (s) incl. activation method	40	34	45
Position Input Latitude	N 51° 22' 35"		
Position Input Longitude	W 001° 49' 50"		
Position Output Latitude	N 51° 22' 36"	N 51° 22' 36"	N 51° 22' 36"
Position Output Longitude	W 001° 49' 52"	W 001° 49' 52"	W 001° 49' 52"
Position Error (m)	49.3	49.3	49.3



Summary: GNSS Self-test without Valid Navigation Input

Protocol	Standard Location Protocol		
	-20	+22	+55
Temperature (°C)	-20	+22	+55
Frame sync verification	N/A	N/A	N/A
Format Flag (1 bit)	N/A	N/A	N/A
Single Radiated burst (ms)	N/A	N/A	N/A
Default Position data	N/A	N/A	N/A
Single burst verification	N/A	N/A	N/A
Actual duration (s) incl. activation method	125	125	125

Full Hex Messages	
Standard Location Protocol with Navigation data applied	
+55°C	FFFED0901E2E6ECB33A03C2FCD371DA4D4D0
Ambient	FFFED0901E2E6ECB33A03C2FCD371DA4D4D0
-20°C	FFFED0901E2E6ECB33A03C2FCD371DA4D4D0
Standard Location Protocol without Navigation data applied	
+55°C	N/A
Ambient	N/A
-20°C	N/A

N/A = Not Applicable (EUT does not transmit a 406MHz burst in the absence of navigation data)



Table F-E.4: GNSS Self-test Mode Actions and Indications

No.	Action/Indication	Time-stamp (HH:MM:SS)	Description of action/indication	Duration of action/indication (sec)	Notes
1	GNSS Self-test mode initiation (distinct action)	00:00:00	Slide main switch to TEST position twice and release	3 seconds	An audible tone occurs each time the slide switch is moved to the TEST position
2	Distinct indication of the GNSS Self-test initiation	00:00:03	1 x audio tone every 4 seconds	-	Tones continue until either step 5 or step 6 occurs
3	GNSS Self-test single burst transmission	00:00:31	Single 406 RF transmission	520ms	Verified by TUV test system
4	GNSS Self-test message position encoding	00:00:31	Single 406 transmission containing valid GPS position	520ms	Verified by TUV test system
5	Distinct indication of the GNSS Self-test PASS result	00:00:33	2 x audio tone followed by strobe light flash	6 seconds	
6	Distinct indication of the GNSS Self-test FAIL result	00:02:00	5 x audio tone	5 seconds	No transmission by the EUT
7	Distinct indication that the manufacturer-declared limited number of GNSS Self-tests is attained	00:00:03	10 x rapid audio tones	3 seconds	Following step 1, the EUT will perform as described with no transmission or further action from the EUT
8	Automatic termination of the Self-test mode, irrespectively of the switch position	-	-	-	See battery current measurements for further information
9	Duration of the GNSS Self-test mode	00:02:05	Maximum duration in the absence of valid GPS signal	-	Duration is less when GPS acquired as described in step 5. Note: Time indicated for visual observation. Battery current measurements show that the complete test time (until current returns to zero) is around 128 seconds.

Summary

The EUT fails to comply* with clause A.3.6 of Cospas-Sarsat T.007.

* Self-Test: EUT continues to draw residual current if the main EUT switch is continuously held in the 'TEST' position. See Battery Current measurements for further details. EUT does not provide distinct indications for the start of the Self-Test, or that RF has been emitted. GNSS Self-Test: EUT does not provide distinct indications that RF has been emitted.



2.8 THERMAL SHOCK

2.8.1 Specification

Cospas-Sarsat T.007, Clause A.2.2

2.8.2 Equipment Under Test and Modification State

Tron 40VDR S/N: 11979 - Modification State 0

2.8.3 Date of Test

06 June 2018

2.8.4 Test Equipment Used

The major items of test equipment used for the above tests are identified in Section 3.1.

2.8.5 Environmental Conditions

Ambient Temperature 23.1°C
Relative Humidity 40.5%



2.8.6 Test Results

Soak Temperature: 20°C
Test Temperature: -10°C

Nominal Frequency

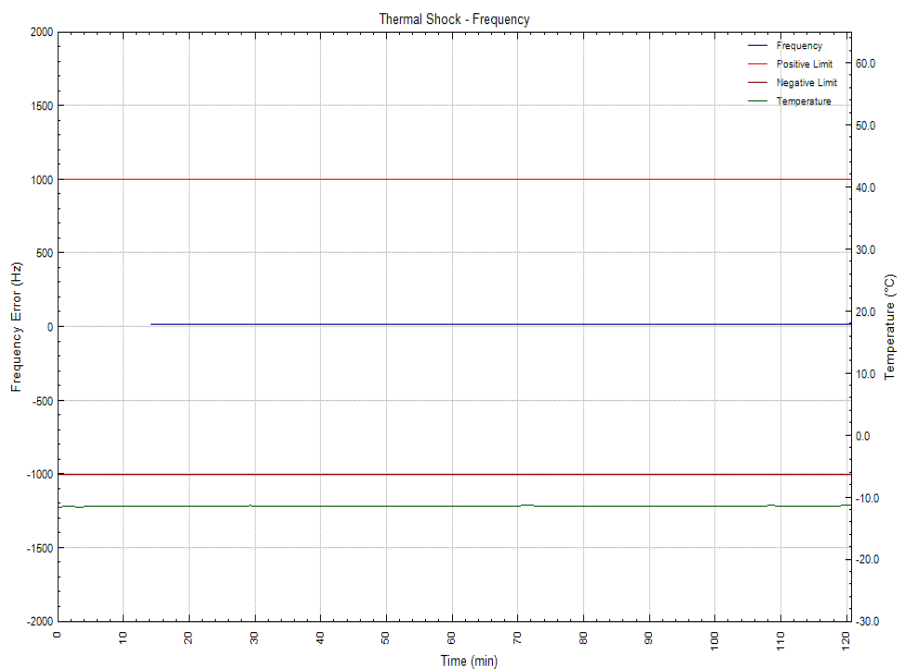



Short Term Stability

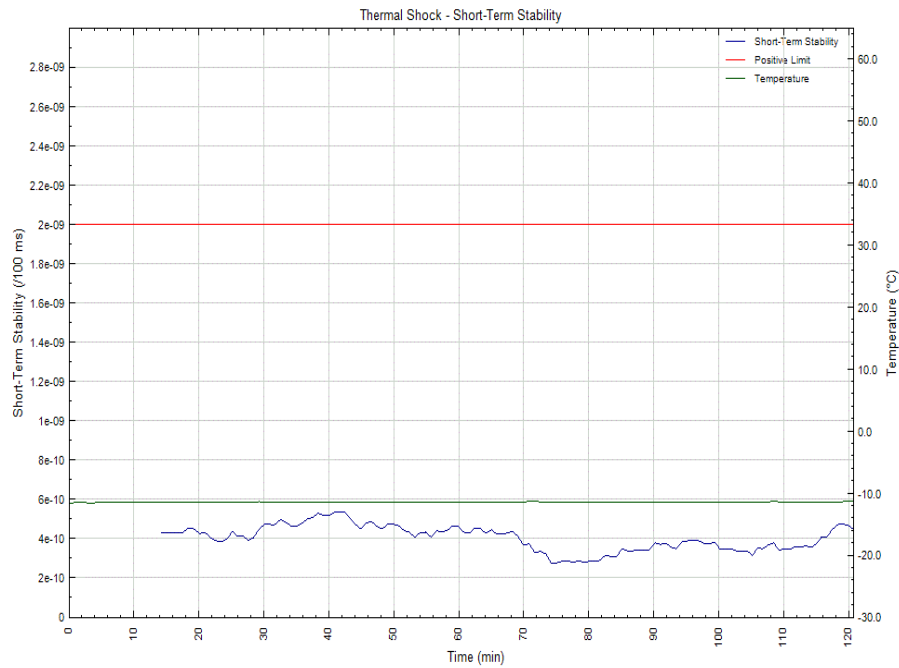

Medium Term Stability, Mean Slope

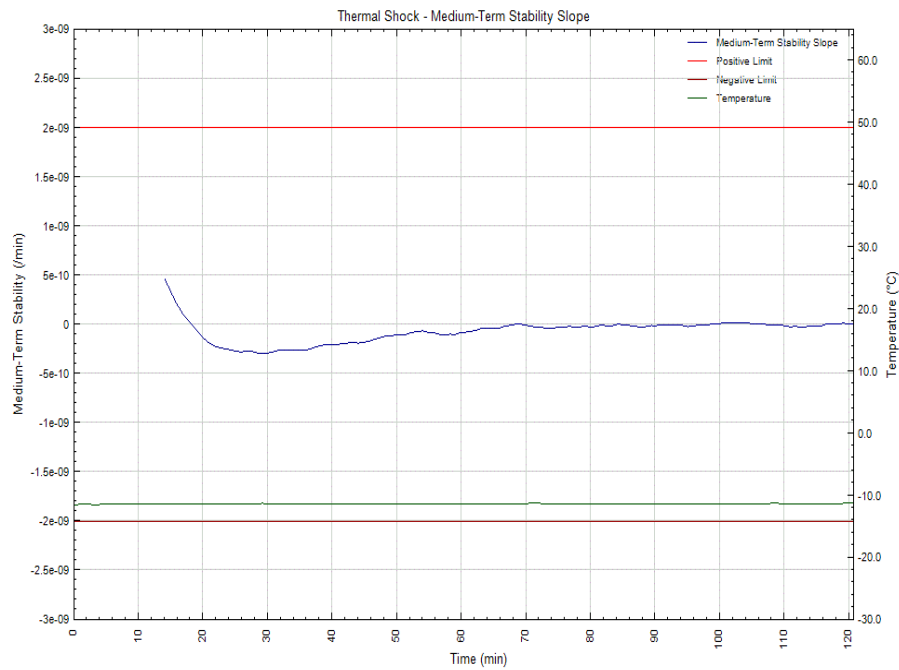



Medium Term Stability, Residual Frequency Variation

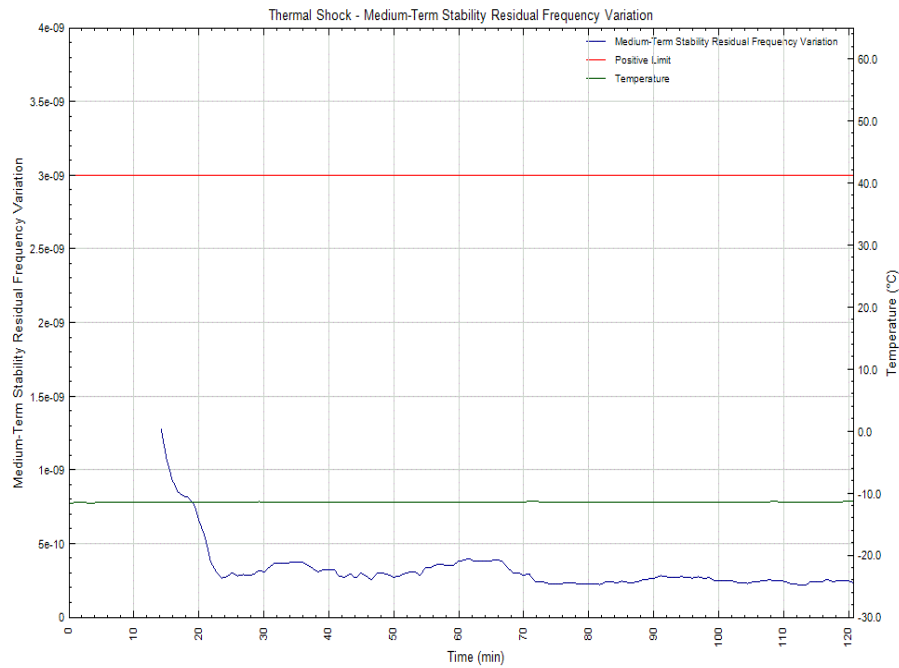

Output Power

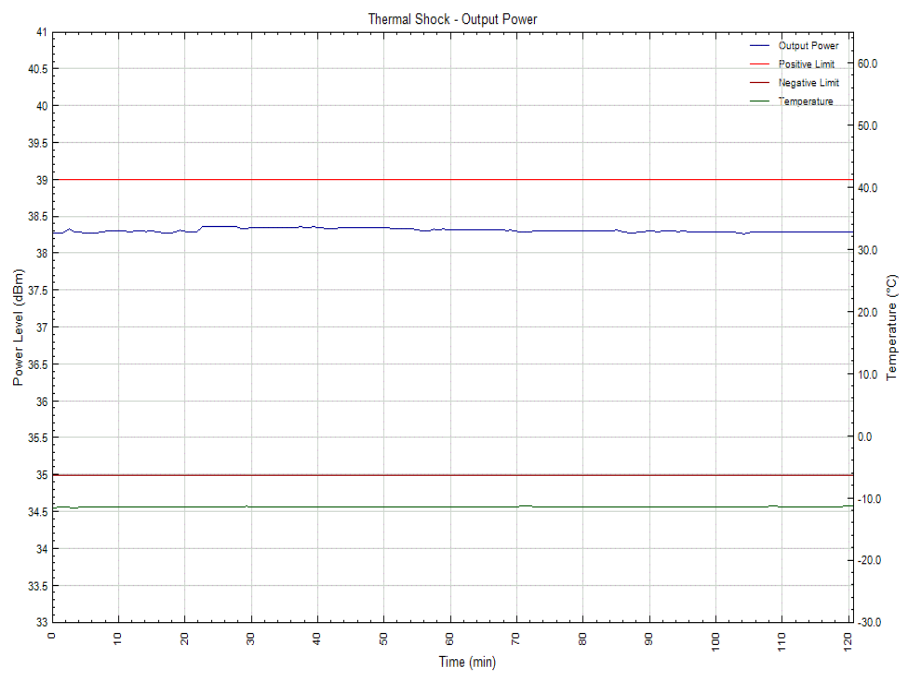



Digital Message

Message	FFFE2F901E2E6ECB7FDFFAD8BEF783E0F66C		
Hex ID	203C5CDD96FFBFF		
Position	None - Default Values		
Parameter	Bit	Data Bits	Decoded Value
Bit synchronization	1-15	1111111111111111	1111111111111111
Frame synchronization	16-24	000101111	000101111
Format Flag	25	1	1
Protocol Flag	26	0	0
Country Code	27-36	0100000001	Norway
Protocol Code	37-40	1110	Standard Test Location Protocol
Undefined	41-64	001011100110111011001011	001011100110111011001011
N/S	65	0	Default
Latitude Degrees	66-72	1111111	Default
Latitude Minutes	73-74	11	Default
E/W	75	0	Default
Longitude Degrees	76-83	11111111	Default
Longitude Minutes	84-85	11	Default
BCH Code (21 Bit)	86-106	010110110001011111011	010110110001011111011
Calculated BCH Code (21 Bit)	-	010110110001011111011	010110110001011111011
Supplementary Data Fixed	107-110	1101	1101
Encoded Position Data Source	111	1	Internal
121.5 MHz Homing	112	1	Yes
Delta Latitude +/-	113	1	Default
Delta Latitude Minutes	114-118	00000	Default
Delta Latitude Seconds	119-122	1111	Default
Delta Longitude +/-	123	1	Default
Delta Longitude Minutes	124-128	00000	Default
Delta Longitude Seconds	129-132	1111	Default
BCH Code (12 Bit)	133-144	011001101100	011001101100
Calculated BCH Code (12 Bit)	-	011001101100	011001101100

Summary

The EUT complies with clause A.2.2 of Cospas-Sarsat T.007.



2.9 OPERATING LIFETIME AT MINIMUM TEMPERATURE

2.9.1 Specification

Cospas-Sarsat T.007, Clause A.2.3

2.9.2 Equipment Under Test and Modification State 1

Tron 40VDR S/N: 11979 - Modification State 1

2.9.3 Date of Test

16 – 28 April 2019

2.9.4 Test Equipment Used

The major items of test equipment used for the above tests are identified in Section 3.1.

2.9.5 Environmental Conditions

Ambient Temperature 22.5°C
Relative Humidity 38.9%

2.9.6 Test Results

Nominal Frequency

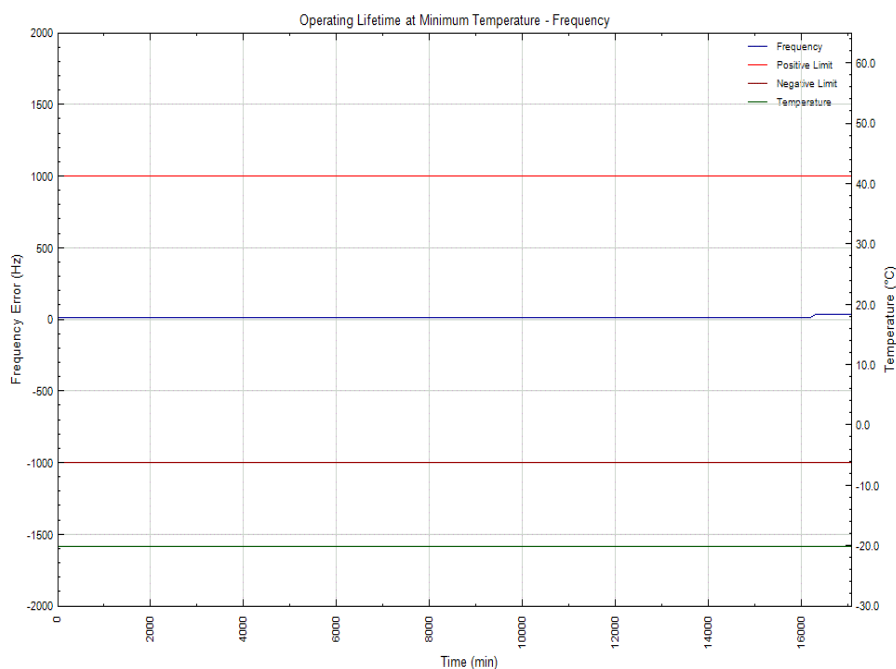

Short Term Stability

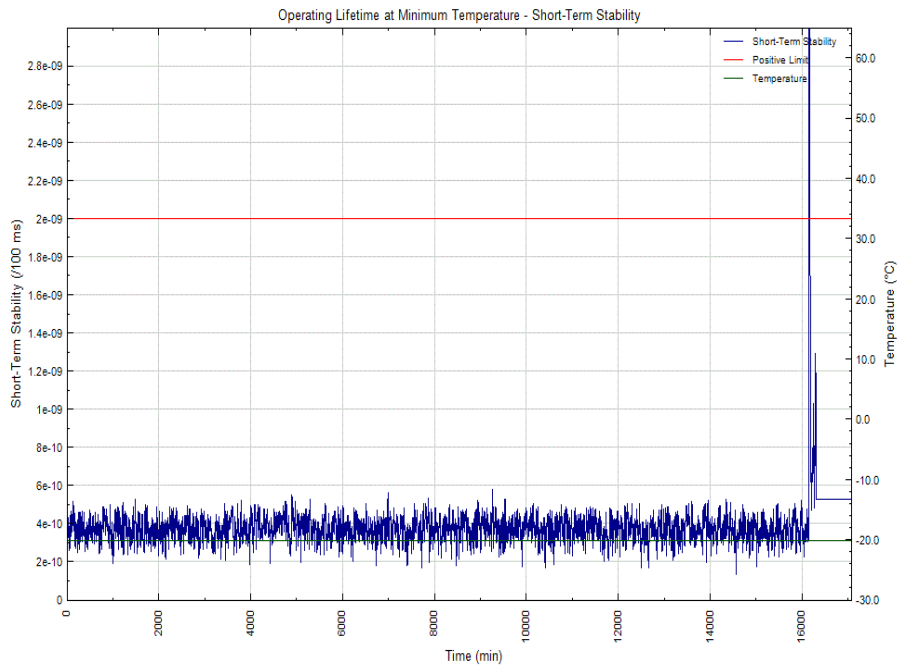

Medium Term Stability, Mean Slope

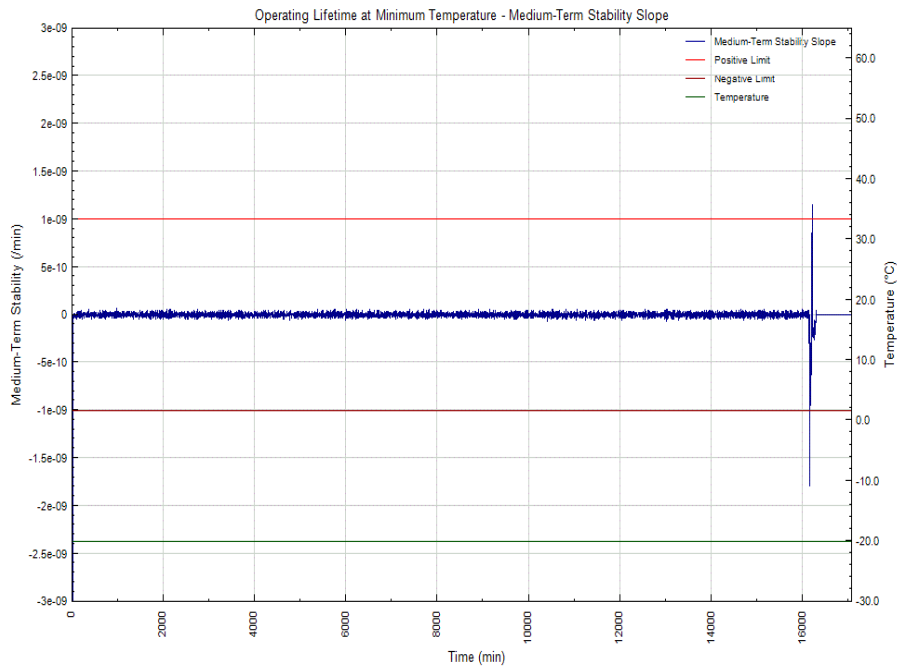

Medium Term Stability, Residual Frequency Variation

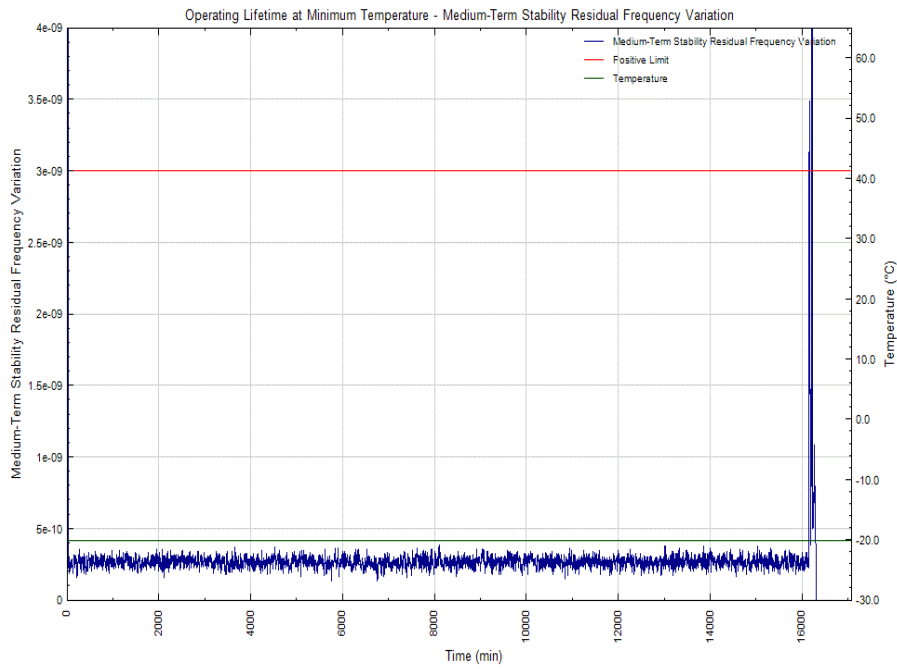

Output Power

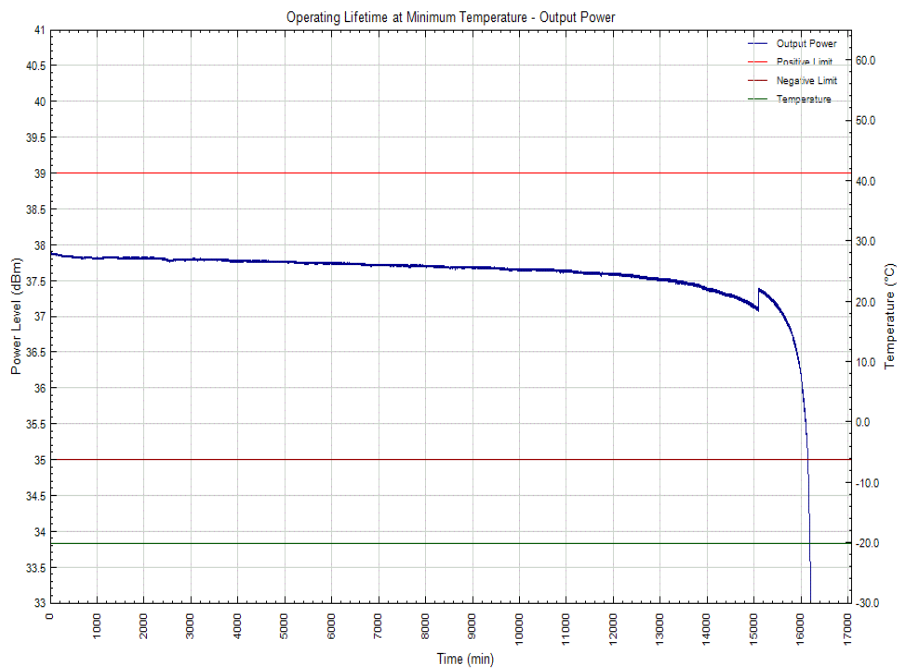

Digital Message

Message	FFFE2F901E2E6ECB7FDFFAD8BEF783E0F66C		
Hex ID	203C5CDD96FFBFF		
Position	None - Default Values		
Parameter	Bit	Data Bits	Decoded Value
Bit synchronization	1-15	111111111111111	111111111111111
Frame synchronization	16-24	000101111	000101111
Format Flag	25	1	1
Protocol Flag	26	0	0
Country Code	27-36	0100000001	Norway
Protocol Code	37-40	1110	Standard Test Location Protocol
Undefined	41-64	001011100110111011001011	001011100110111011001011
N/S	65	0	Default
Latitude Degrees	66-72	1111111	Default
Latitude Minutes	73-74	11	Default
E/W	75	0	Default
Longitude Degrees	76-83	1111111	Default
Longitude Minutes	84-85	11	Default
BCH Code (21 Bit)	86-106	010110110001011111011	010110110001011111011
Calculated BCH Code (21 Bit)	-	010110110001011111011	010110110001011111011
Supplementary Data Fixed	107-110	1101	1101
Encoded Position Data Source	111	1	Internal
121.5 MHz Homing	112	1	Yes
Delta Latitude +/-	113	1	Default
Delta Latitude Minutes	114-118	00000	Default
Delta Latitude Seconds	119-122	1111	Default
Delta Longitude +/-	123	1	Default
Delta Longitude Minutes	124-128	00000	Default
Delta Longitude Seconds	129-132	1111	Default
BCH Code (12 Bit)	133-144	011001101100	011001101100
Calculated BCH Code (12 Bit)	-	011001101100	011001101100

Test Data (0 min – 30 min)

#	Output Power (dBm)	Nominal Frequency (Hz)	Short Term Stability (/100 ms)	Medium Term Stability – Slope (min)	Medium Term Stability – Residual Frequency Variation (no units)	Time (h)
1	36.13	-	-	-	-	0.000
2	36.15	-	-	-	-	0.014
3	36.15	-	-	-	-	0.027
4	36.15	-	-	-	-	0.040
5	36.15	-	-	-	-	0.055
6	36.14	-	-	-	-	0.069
7	36.14	-	-	-	-	0.084
8	36.14	-	-	-	-	0.097
9	36.14	-	-	-	-	0.110
10	36.12	-	-	-	-	0.125
11	36.11	-	-	-	-	0.138
12	36.1	-	-	-	-	0.152
13	36.13	-	-	-	-	0.167
14	36.13	-	-	-	-	0.180
15	36.12	-	-	-	-	0.193
16	36.12	-	-	-	-	0.208
17	36.12	-	-	-	-	0.222
18	36.12	406.0369900	3.784E-10	-5.440E-09	1.207E-08	0.235
19	36.12	406.0369883	3.921E-10	-4.581E-09	1.199E-08	0.249
20	36.12	406.0369868	4.155E-10	-3.703E-09	1.132E-08	0.262
21	36.11	406.0369854	4.291E-10	-2.838E-09	1.008E-08	0.276
22	36.11	406.0369842	4.338E-10	-2.009E-09	8.221E-09	0.289
23	36.09	406.0369832	4.336E-10	-1.268E-09	5.867E-09	0.303
24	36.09	406.0369825	4.067E-10	-7.000E-10	3.427E-09	0.317
25	36.1	406.0369821	3.972E-10	-3.523E-10	1.631E-09	0.330
26	36.11	406.0369819	4.056E-10	-1.932E-10	8.036E-10	0.345
27	36.11	406.0369818	3.586E-10	-1.102E-10	5.220E-10	0.358
28	36.1	406.0369817	3.524E-10	-5.674E-11	3.343E-10	0.372
29	36.11	406.0369817	3.489E-10	-2.815E-11	2.903E-10	0.386
30	36.11	406.0369817	3.836E-10	-2.050E-11	2.531E-10	0.399
31	36.1	406.0369817	4.039E-10	-2.515E-11	2.646E-10	0.413
32	36.1	406.0369817	4.125E-10	-1.880E-11	2.518E-10	0.426
33	36.1	406.0369816	3.868E-10	-1.392E-11	2.637E-10	0.441
34	36.1	406.0369816	3.958E-10	-3.433E-12	2.256E-10	0.454
35	36.1	406.0369816	3.591E-10	-6.463E-13	2.303E-10	0.468
36	36.09	406.0369816	3.460E-10	2.072E-12	2.329E-10	0.482
37	36.08	406.0369816	3.364E-10	-4.913E-12	2.414E-10	0.496
38	36.09	406.0369816	3.080E-10	-2.941E-12	2.441E-10	0.510

Results outside of the specification are marked in red text.

121MHz Homing Transmitter – Duty Cycle (Start of Test)

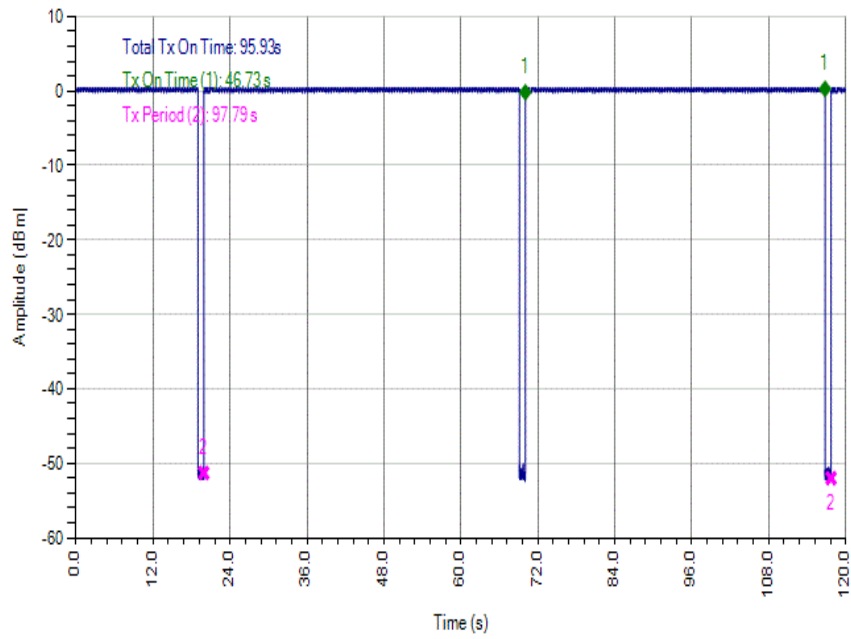

$$\text{Duty Cycle} = 95.93 / (95.93 + 1.86) = 98.1\%$$

121MHz Homing Transmitter – Duty Cycle (End of Test)

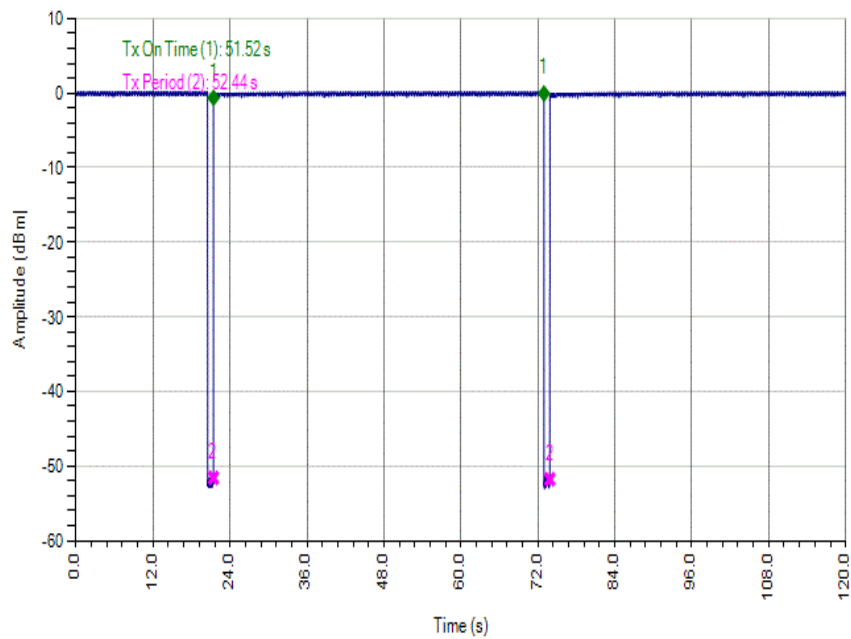

$$\text{Duty Cycle} = 51.52 / (51.52 + 0.92) = 98.25\%$$

121 Homing Transmitter Power

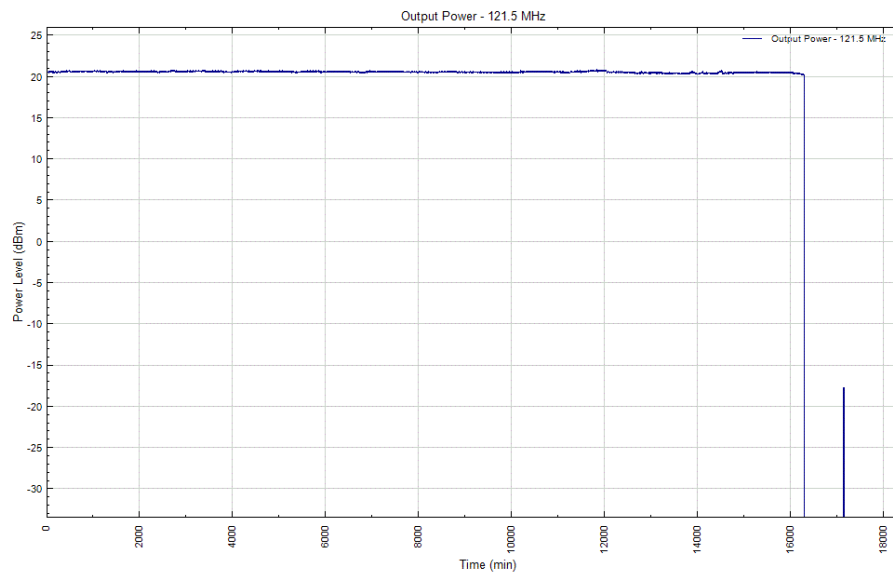

121 Homing Transmitter Frequency

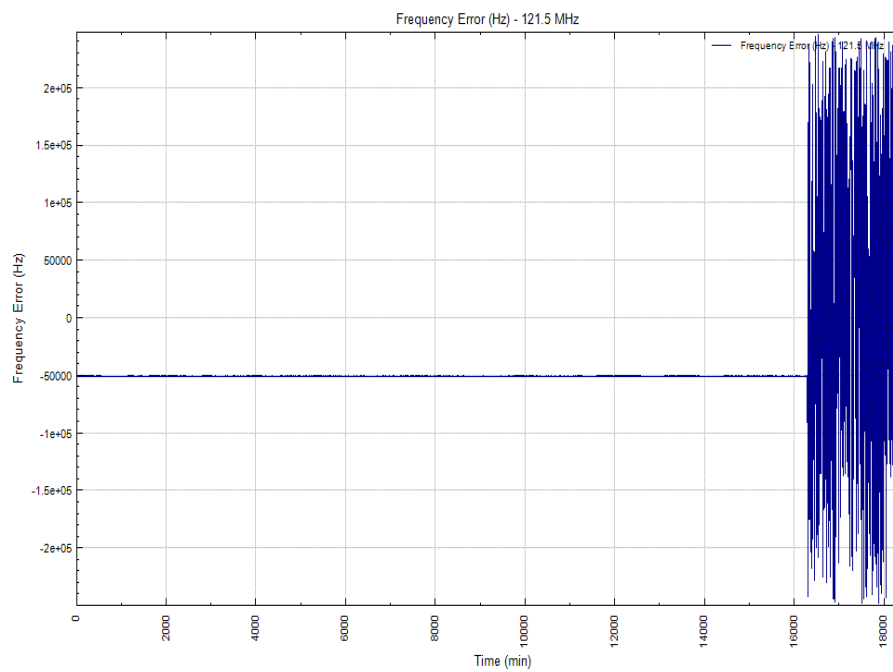

Operating Current Measurements and Analysis

System Configurations and Operating Modes

System Configuration →	A, No Ancillaries	B, Float Free Case + VDR data link
Operational Mode ↓		
1, Standby	A1	B1
2, ON at EUT switch	A2	B2
3, ON at EUT (GPS Sleep)	A3	B3
4, ON at Water Contacts	A4	N/A
5, ON @WCs (GPS Sleep)	A5	N/A
6, Self-test	A6	B6
7, GNSS Self-test (Timeout)	A7	B7
8, GNSS Self-test (Burst)	A8	B8

SCOMM Results as per C/S T.007 Table F-E.1:

Beacon Operating Modes	Mode: Manually selectable or Automatic	Measurement interval, sec	Average Current, mA	Peak Current, mA
A1	A	599.9	0.0006692	0.0006818
B1	M	599.9	0.00001724	0.00004205
A2	M	2097.0	44.04	1611
B2	M	2099.0	43.42	1592
A3	M	417.2	41.57	1595
B3	M	415.1	40.12	1528
A4	M	2093.0	43.74	1555
A5	M	420.1	39.30	1537
A6	M	16.47	68.15	1512
B6	M	16.47	67.81	1464
A7	M	128.8	28.48	31.24
B7	M	126.7	29.07	31.24
A8	M	44.9	38.36	1486
B8	M	47.8	40.32	1501

The sampling interval was a nominal 80 ms for all measurements.

Worst Case System Configurations / Operating Modes

“Lifetime in service” drains (highest average current):

Standby: A1 – Standby

Self-test: A6 – Self-test

GNSS Self-test (Timeout): B7 – Float Free Case + VDR data link GNSS Self-test (Timeout)

GNSS Self-test (Burst): B8 – Float Free Case + VDR data link GNSS Self-test (Timeout)

Note: “Worst case” GNSS Self-test is a test which almost times out but acquires at the last possible moment; to account for this, the “burst” discharge was added to the “timeout” discharge.

Operating mode during lifetime test (highest average current):

A2 – No Ancillaries, ON at EUT switch (subject to GNSS receiver duty cycle)

Conditions during lifetime test:

GNSS Signals: None applied

Current Measurement Plots

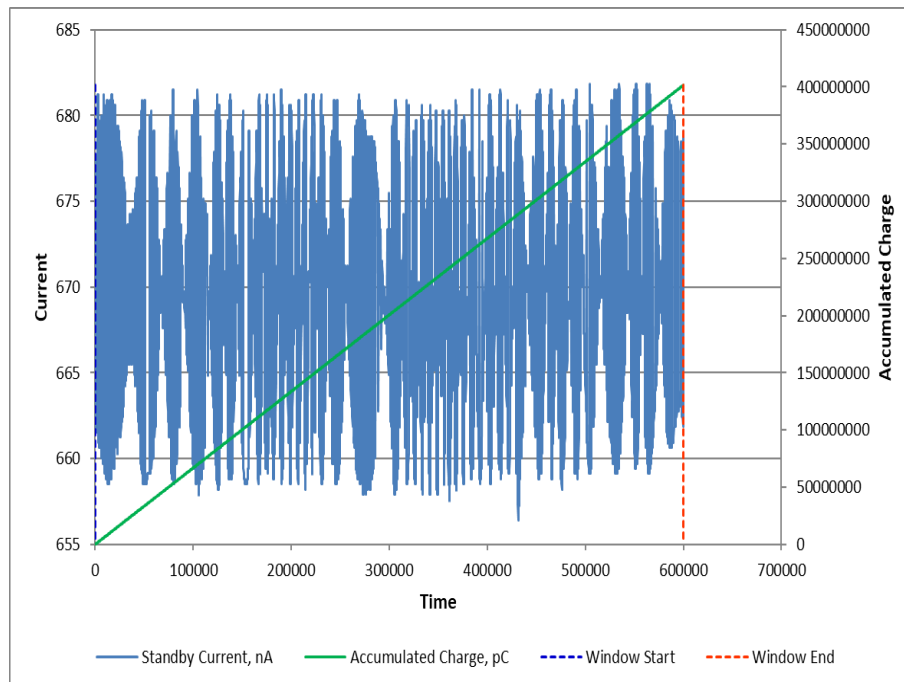

Standby: A1

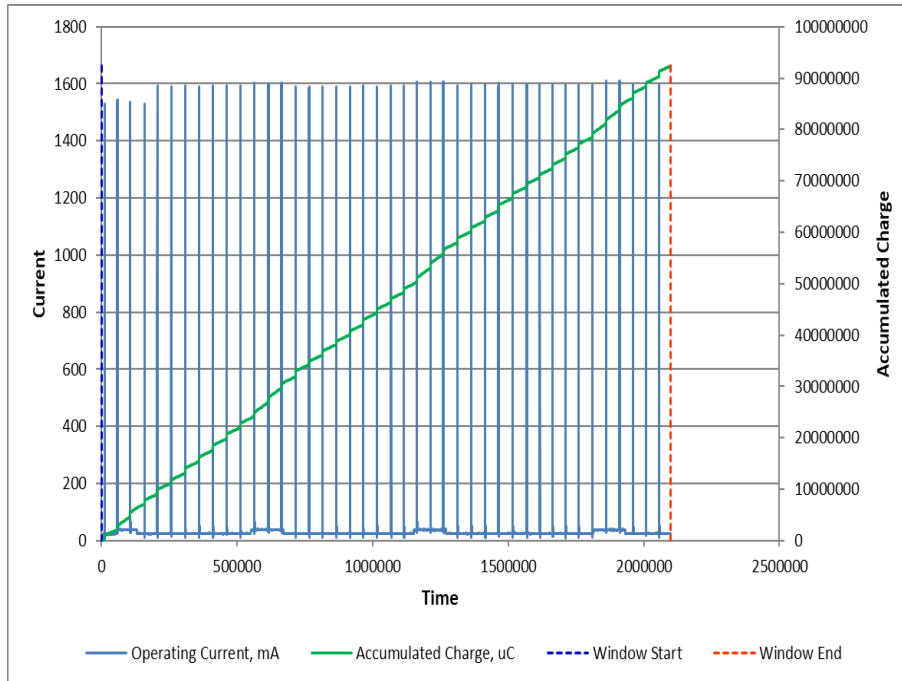

On at EUT Switch: A2

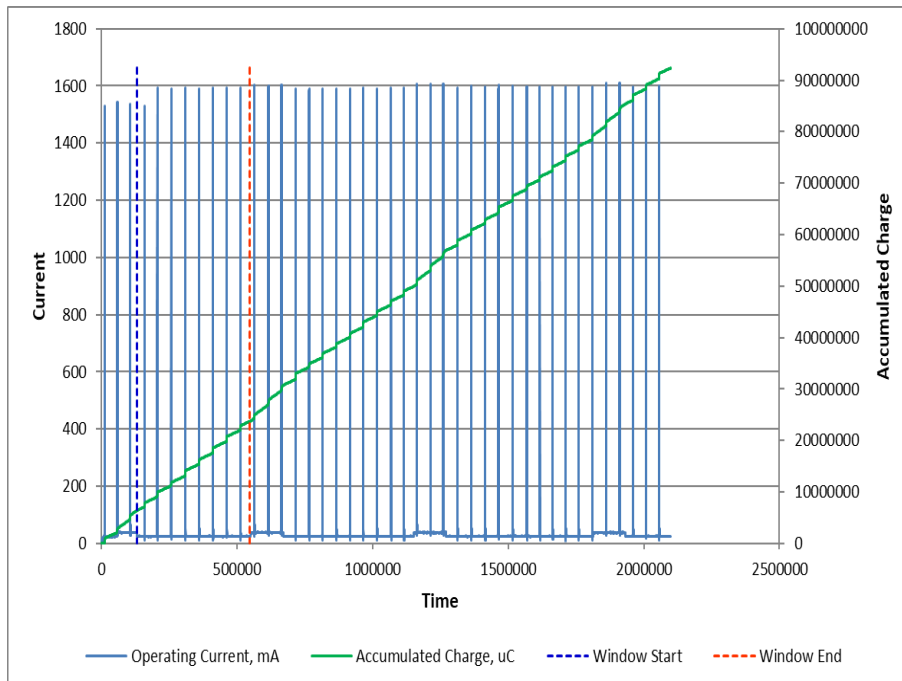

On at EUT (GPS Sleep): A3

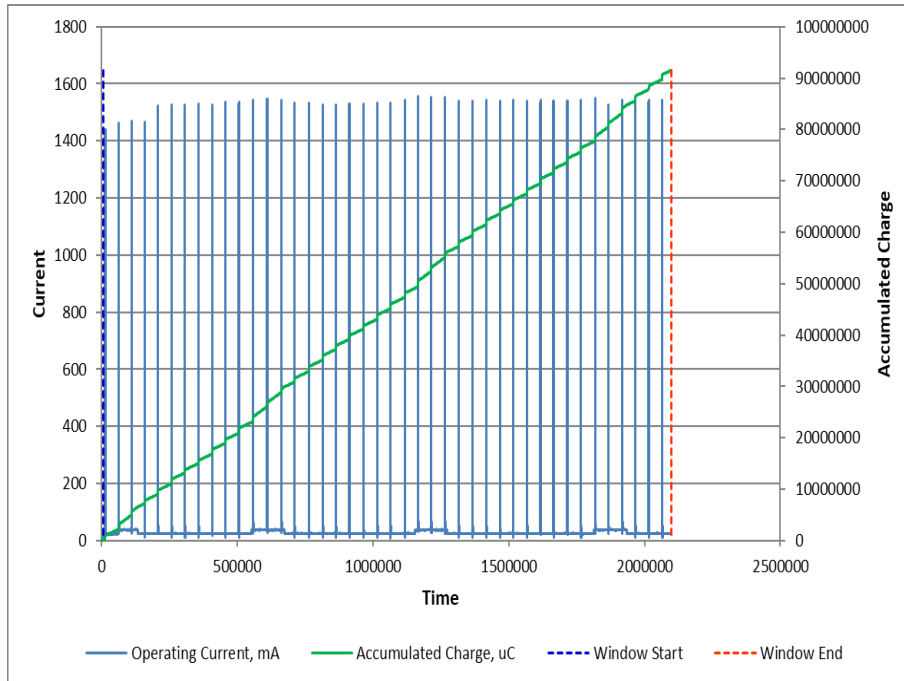

On at Water Contacts: A4

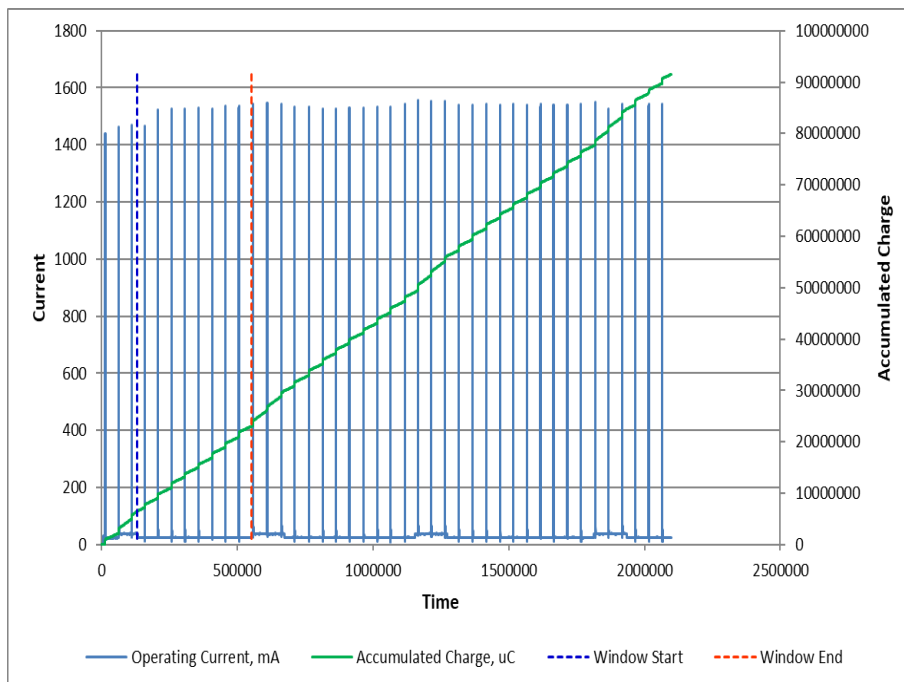

On at Water Contacts (GPS Sleep): A5

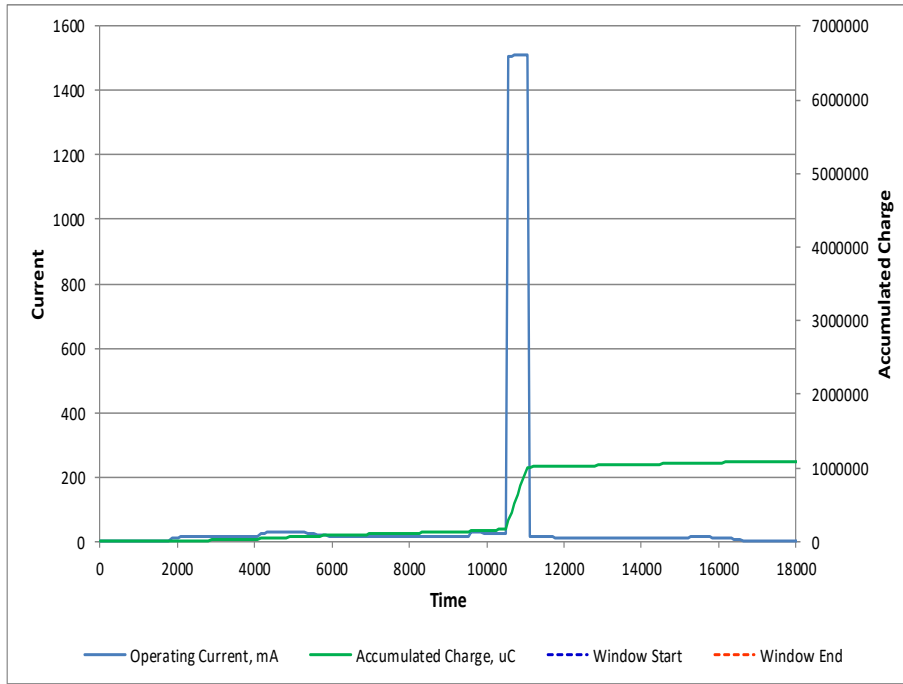

Self-test: A6

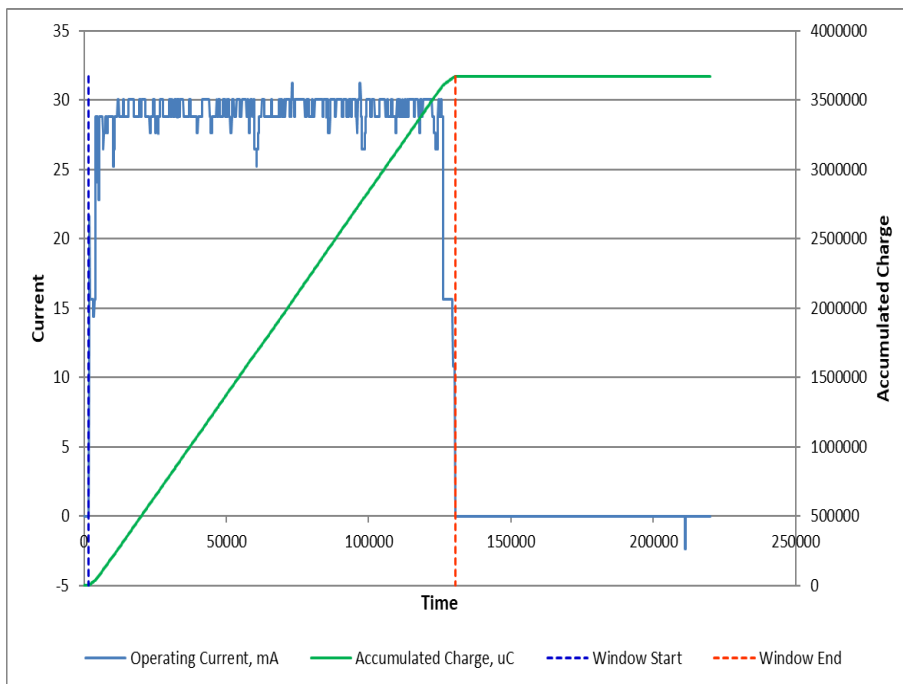

GNSS Self-test (Timeout): A7

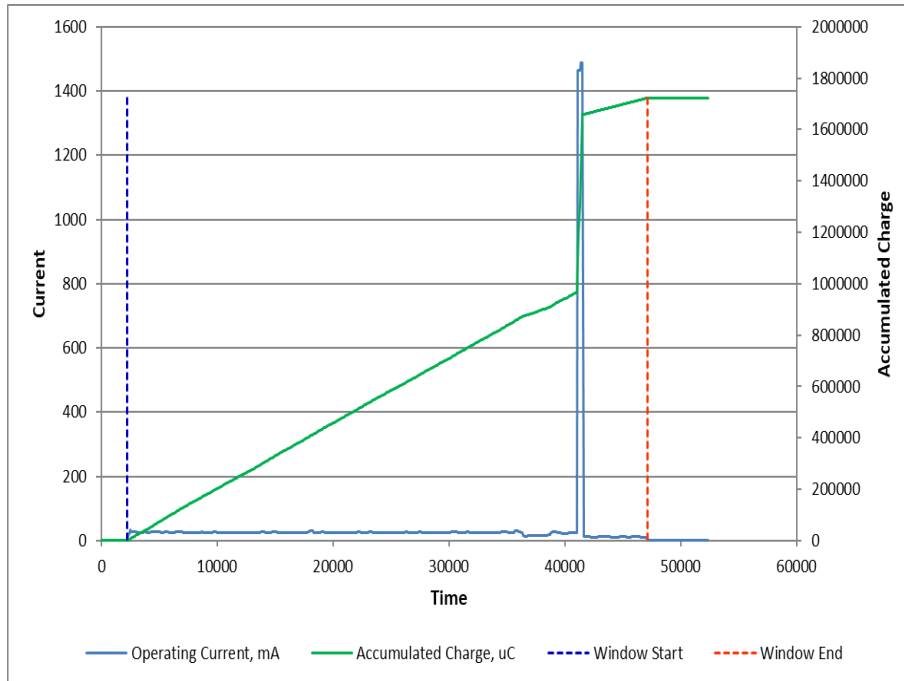

GNSS Self-test (Burst): A8

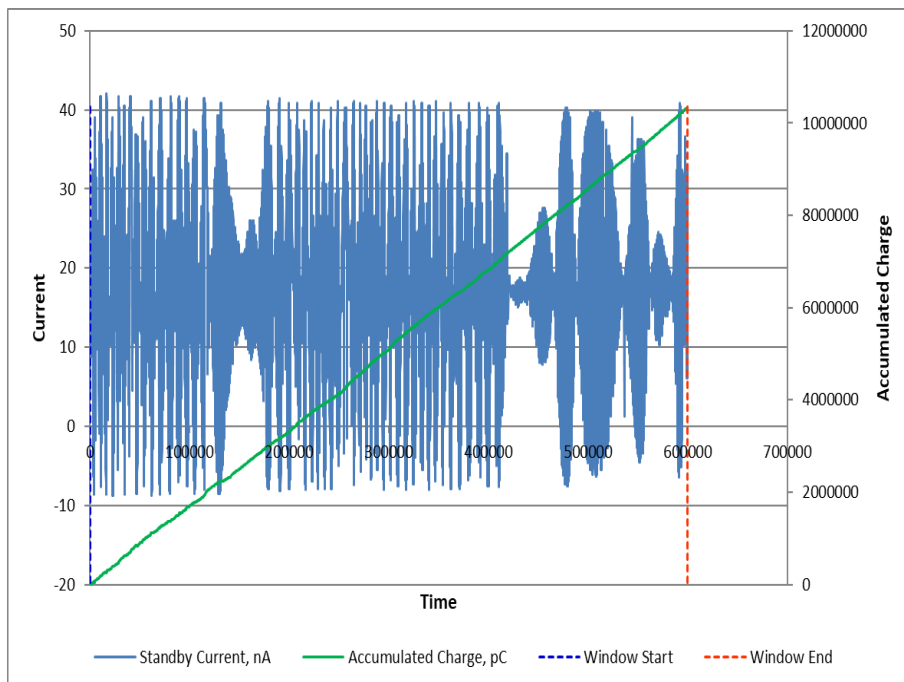

Float Free Case + VDR data link, Standby: B1

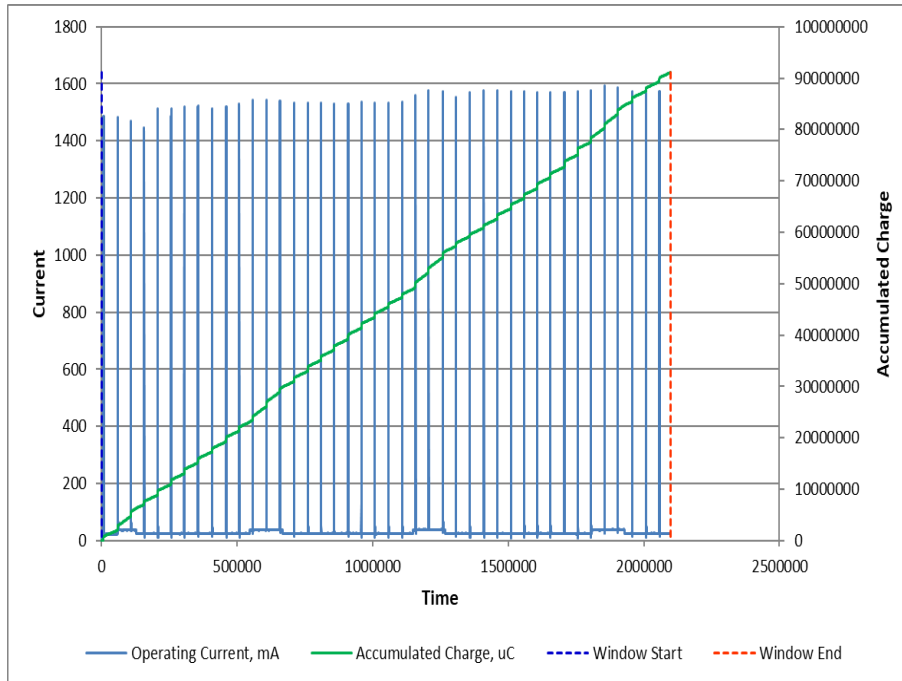

Float Free Case + VDR data link, On at EUT Switch: B2

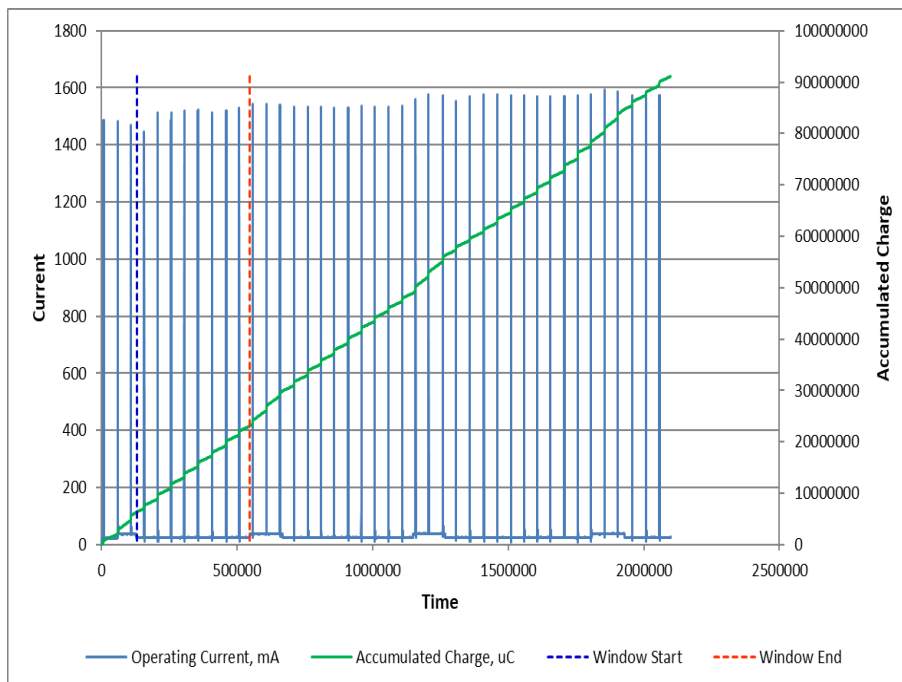

Float Free Case + VDR data link, On at EUT (GPS Sleep): B3

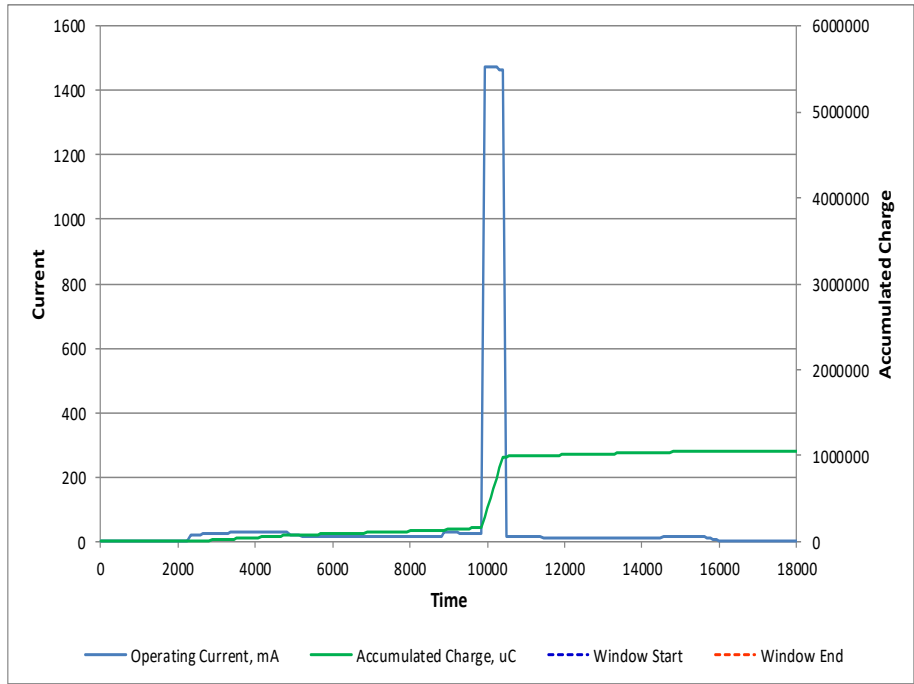

Float Free Case + VDR data link, Self-test: B6

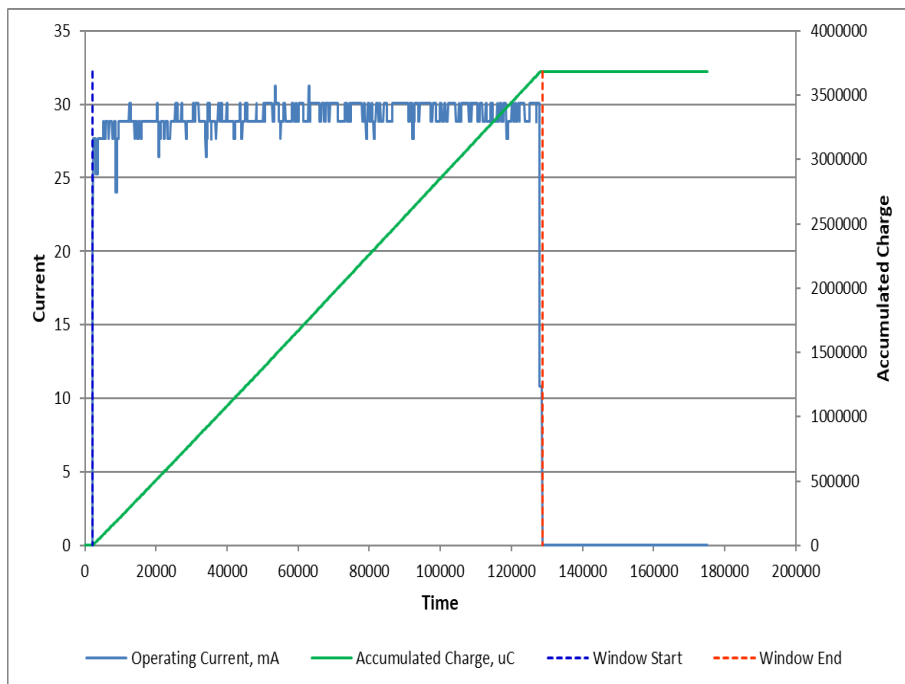

Float Free Case + VDR data link, GNSS Self-test (Timeout): B7

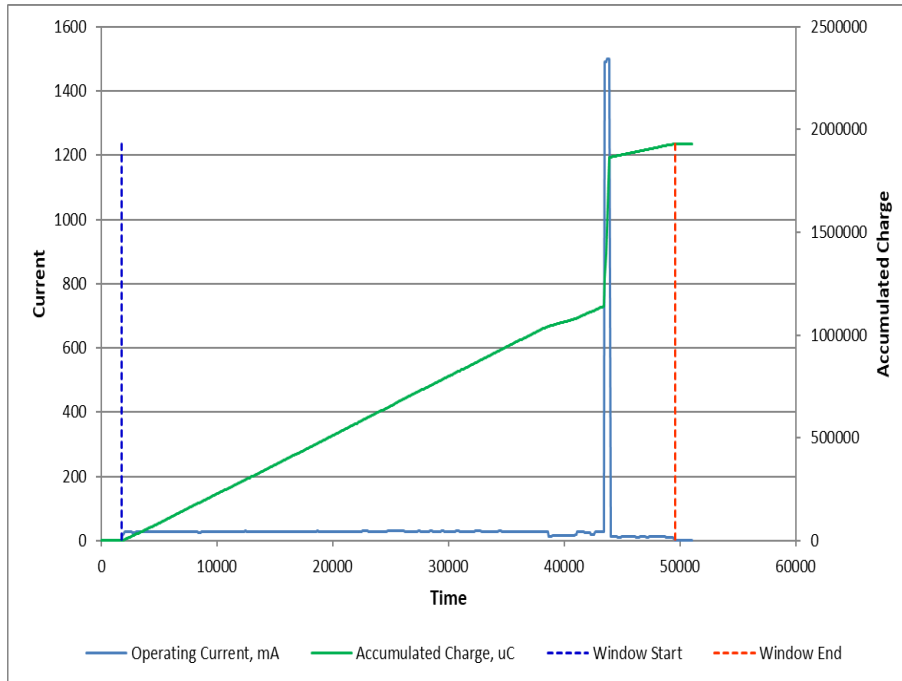

Float Free Case + VDR data link, GNSS Self-test (Burst): B8

Auto-termination checks

The following plots show the EUT response during Self-Test and GNSS Self-Test if the activation switch is continuously held in the TEST position during and beyond the normal duration of the test:

Self-Test

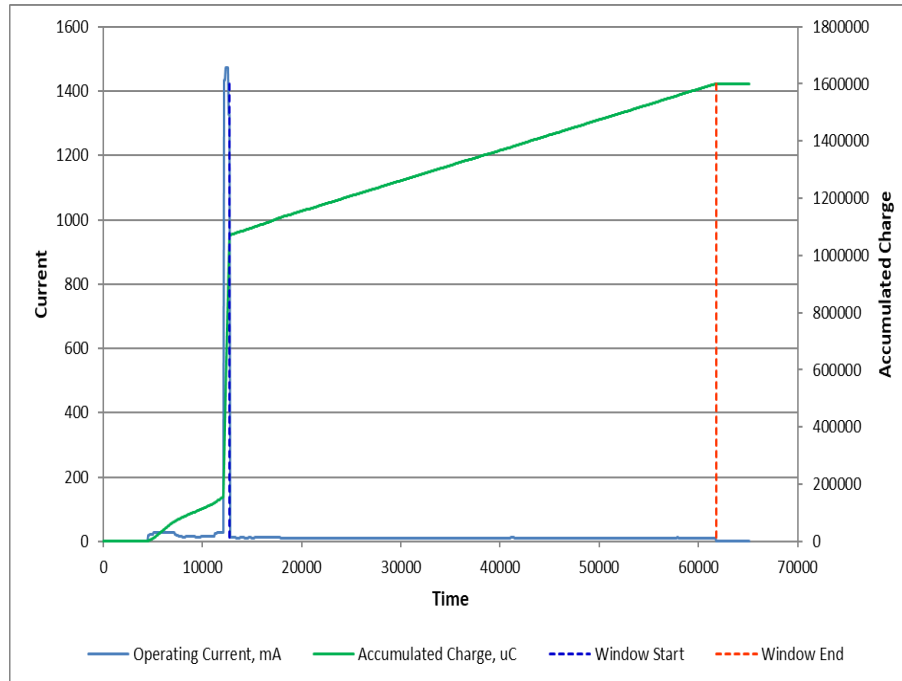

Self-Test performs as expected. However, at the end of the normal Self-Test duration the EUT continues to draw a residual current of 10.8mA.

GNSS Self-Test

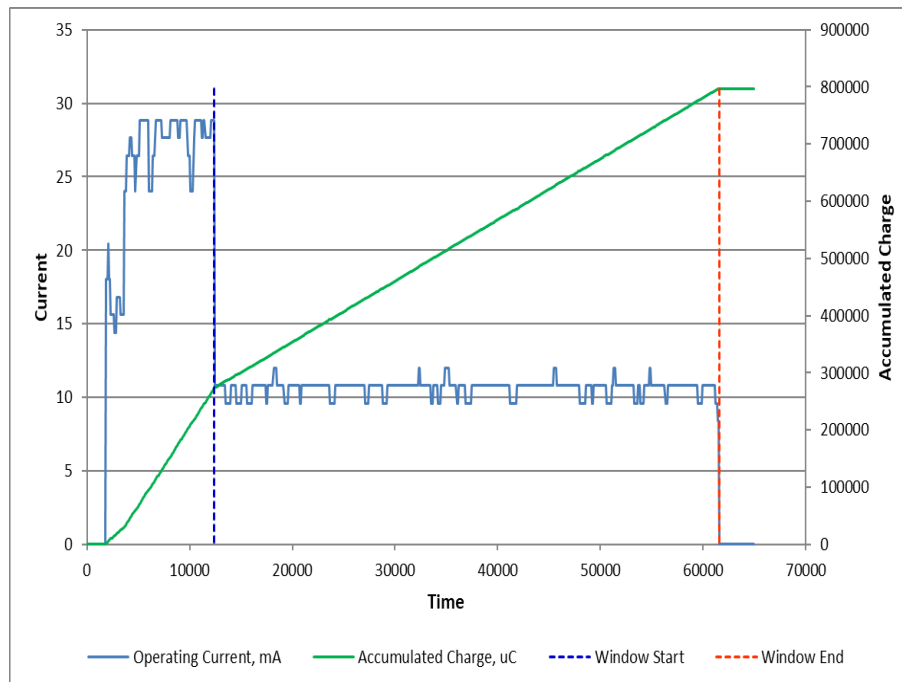

It should be noted that the TEST switch must be released in order for a GNSS Self-Test to take place. If the switch is not released, the following comment applies: GNSS Self-Test procedure is not performed and terminates after 10 seconds. The EUT continues to draw a residual current of 10.62mA.

Battery Conditioning Calculations

As per C/S T.007 Table F-E.2:

Characteristic	Designation	Units	Value	Comments
Beacon manufacturers declared maximum allowed cell shelf-life (from date of cell manufacture to date of battery pack installation in the beacon)	T _{CS} or TCS	Years	2.5	
Declared beacon battery replacement period (from date of installation in the beacon to expiry date marked on the beacon)	T _{BR} or TBR	Years	5	
Battery pack electrical configuration	-	-		
Cell model and cell chemistry	-	-		
Nominal cell capacity	-	Ah	18	
Nominal battery pack capacity	C _{BN}	Ah	18	
Annual battery cell capacity loss (self-discharge) due to aging, as specified by cell manufacturer at ambient temperature	L _{SDC}	%	3	
Calculated battery pack capacity loss due to self-discharge: L _{CBN} = C _{BN} - [C _{BN} * (1 - L _{SDC} / 100) ^{TBR+TCS}]	L _{CBN}	Ah	3.6761	
Number of self-tests per year	N _{ST}	-	12	
Average battery current during a self-test	I _{ST}	mA	68.15	
Maximum duration of a self-test	T _{ST}	s	17	Manufacturer declared value
Calculated battery pack capacity loss due to self-tests during battery replacement period: L _{ST} = I _{ST} * T _{ST} * T _{BR} * (N _{ST} / 3600)	L _{ST}	mAh	19.31	
Maximum Number of GNSS self-tests between battery replacements	N _{GST}	-	60	
Average battery current during a GNSS self-test - Timeout (No GPS acquire)	I _{GST}	mA	29.07	
Maximum duration of a GNSS self-test (Timeout)	T _{GST}	s	130	Manufacturer declared value
Average battery current during a GNSS self-test - Bursts (GPS acquired)	I _{GST}	mA	40.32	
Duration of a GNSS self-test (Burst)	T _{GST}	s	47.8	
Calculated battery pack capacity loss due to GNSS self-tests during battery replacement period: L _{GST} = I _{GST} * T _{GST} * (N _{GST} / 3600)	L _{GST}	mAh	95.1066	
Average stand-by battery pack current	I _{SB}	mA	0.000669	
Other Capacity Losses	L _{OTH}	mAh	0.0	See 'Additional Comments' below
Battery pack capacity loss due to constant operation of circuitry prior to beacon activation: L _{ISB} = I _{SB} * T _{BR} * 8760	L _{ISB}	mAh	29.3022	
Calculated value of the battery pack pre-test discharge L _{CDC} = L _{CBN} + 1.65((L _{ST} + L _{GST} + L _{ISB})/1000) + (L _{OTH} /1000)	L _{CDC}	Ah	3.9133	

Characteristic	Designation	Units	Value	Comments
Method of discharge	-	-	Pre-test Operating Duration	
Discharge current	L _D	mA	44.04	
Discharge duration, T _D = L _{CDC} / (L _D * 1000)	T _D	h	88.86	Actual Discharge was 96h

Characteristic	Designation	Units	Value	Comments
Method of discharge	-	-	Pre-test Operating Duration	
Discharge current	L _D	mA	44.04	
Discharge duration, T _D = L _{CDC} / (L _D * 1000)	T _D	h	88.86	Actual Discharge was 96h

Battery Conditioning Results

A fresh battery was used for the test; it was discharged by operation inside the EUT for the pre-test discharge duration calculated as follows:

$$\text{Pre-test discharge (L}_{\text{CDC}}) \text{ [mAh]} = 3913.3$$

$$\text{Operating mode current [mA]} = 44.04$$

$$\text{Pre-test discharge duration [h]} = \frac{3913.3}{44.04}$$

$$\text{Pre-test discharge duration [h]} = 88.86$$

The actual discharge duration was 96 h resulting in a discharge of 4227.84 mAh; an over-test of 12.4 %.

Additional Comments

Battery Current measurements show that a constant residual current of 10.8mA is drawn from the EUT battery should the EUT switch be held in the TEST position after completion of a Self-Test or GNSS Self-Test.

Calculations show that a battery with a full capacity of 18Ah would be depleted after;

$$18 / 0.0108 = 1698 \text{ hours} = 69.4 \text{ days.}$$

Summary

The EUT complies with clause A.2.3 of Cospas-Sarsat T.007.

2.10 FREQUENCY STABILITY TEST WITH TEMPERATURE GRADIENT

2.10.1 Specification

Cospas-Sarsat T.007, Clause A.2.4

2.10.2 Equipment Under Test and Modification State

Tron 40VDR S/N: 11979 - Modification State 0

2.10.3 Date of Test

04 June 2018

2.10.4 Test Equipment Used

The major items of test equipment used for the above tests are identified in Section 3.1.

2.10.5 Environmental Conditions

Ambient Temperature 24.4°C

Relative Humidity 42.8%

2.10.6 Test Results

Full Test

Nominal Frequency

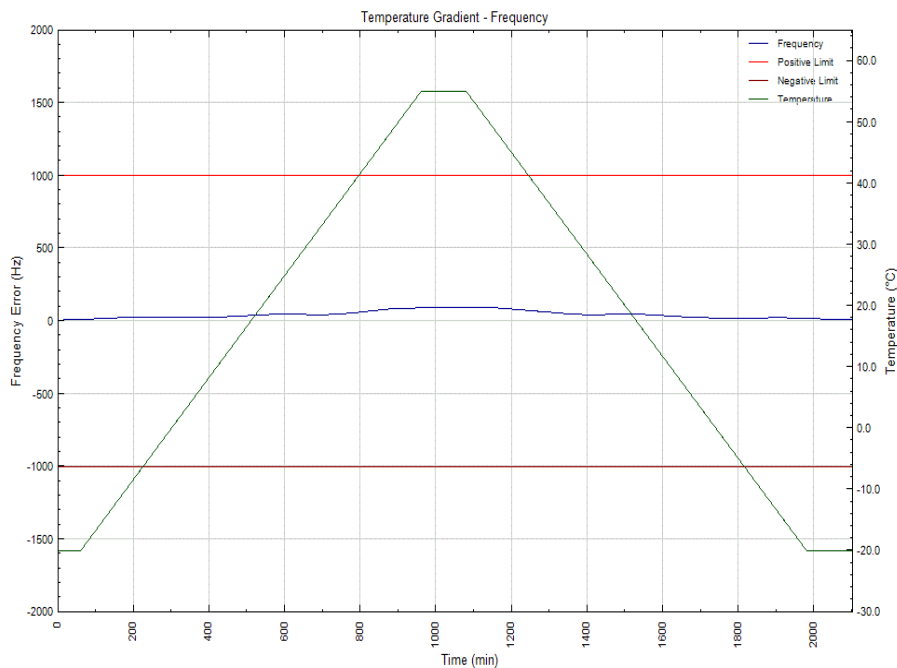

Short Term Stability

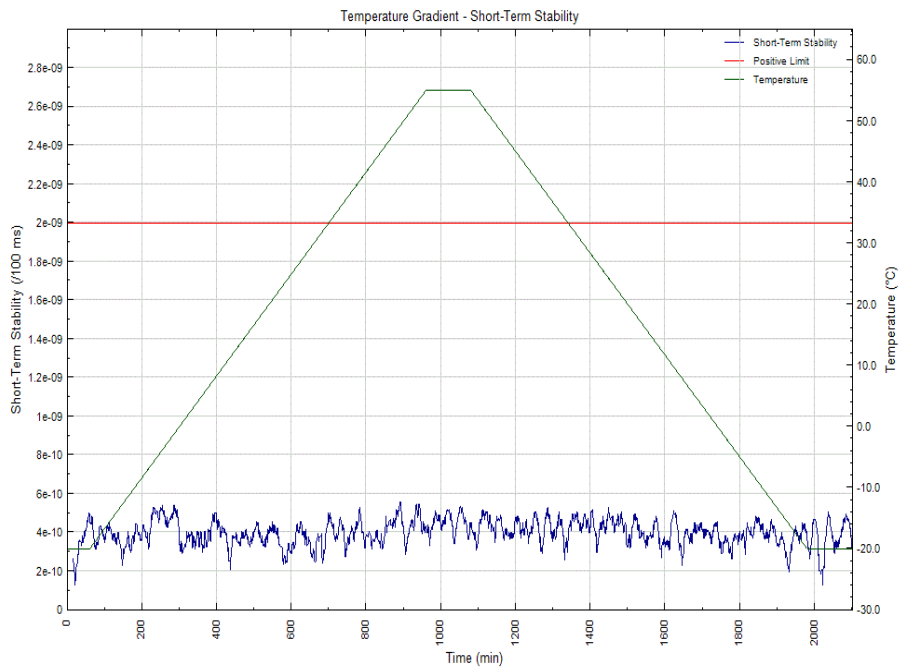

Medium Term Stability, Mean Slope

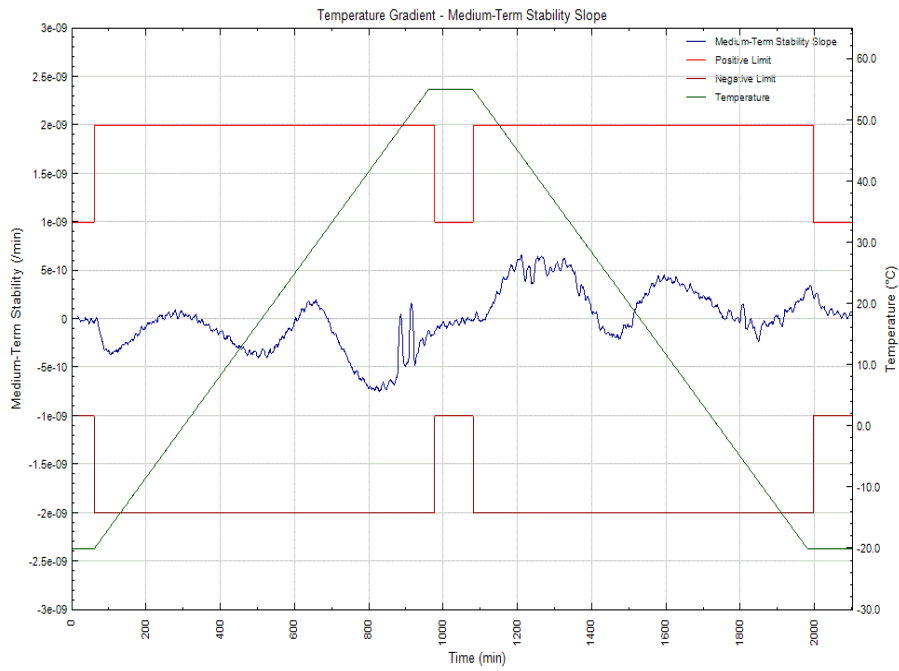

Medium Term Stability, Residual Frequency Variation

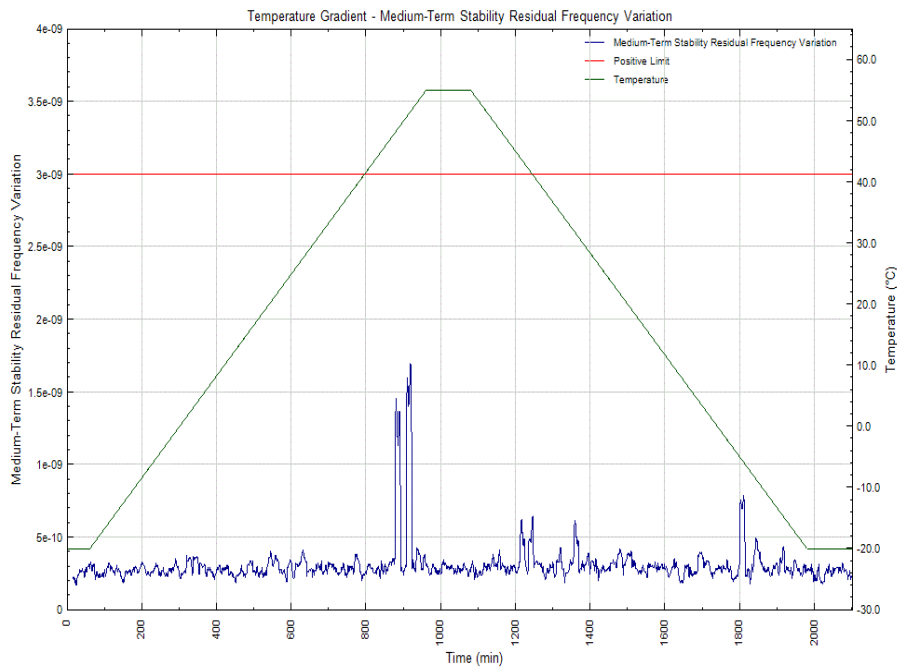

Output Power

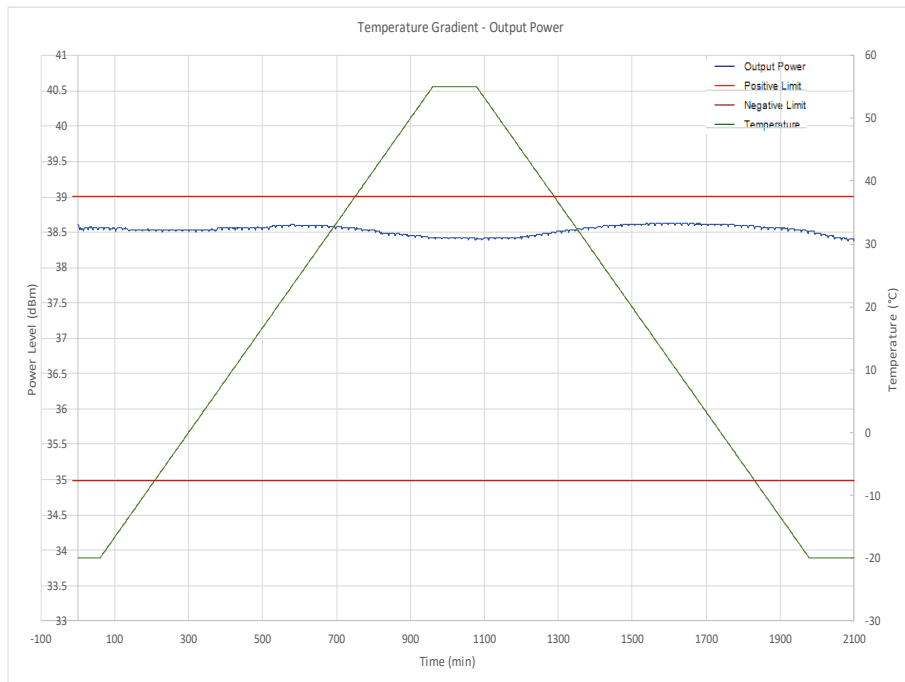

Digital Message

Message	FFFE2F901E2E6ECB7FDFFAD8BEF783E0F66C		
Hex ID	203C5CDD96FFBFF		
Position	None - Default Values		
Parameter	Bit	Data Bits	Decoded Value
Bit synchronization	1-15	111111111111111	111111111111111
Frame synchronization	16-24	000101111	000101111
Format Flag	25	1	1
Protocol Flag	26	0	0
Country Code	27-36	010000001	Norway

Protocol Code	37-40	1110	Standard Test Location Protocol
Undefined	41-64	001011100110111011001011	001011100110111011001011
N/S	65	0	Default
Latitude Degrees	66-72	1111111	Default
Latitude Minutes	73-74	11	Default
E/W	75	0	Default
Longitude Degrees	76-83	11111111	Default
Longitude Minutes	84-85	11	Default
BCH Code (21 Bit)	86-106	010110110001011111011	010110110001011111011
Calculated BCH Code (21 Bit)	-	010110110001011111011	010110110001011111011
Supplementary Data Fixed	107-110	1101	1101
Encoded Position Data Source	111	1	Internal
121.5 MHz Homing	112	1	Yes
Delta Latitude +/-	113	1	Default
Delta Latitude Minutes	114-118	00000	Default
Delta Latitude Seconds	119-122	1111	Default
Delta Longitude +/-	123	1	Default
Delta Longitude Minutes	124-128	00000	Default
Delta Longitude Seconds	129-132	1111	Default
BCH Code (12 Bit)	133-144	011001101100	011001101100
Calculated BCH Code (12 Bit)	-	011001101100	011001101100



TCXO

Model: E4520

S/No: 0200

Full Test

MTS Characteristic	Time (h)	Temp. (°C)	tot	osc	beacon_wc	MAX-OSC	beacon_max	Ageing factor	beacon_5 year	Limit	Result
Residual	15.30	51.1	1.699E-09	7.463E-10	1.526E-09	2.00E-09	2.516E-09	2.00E-10	2.716E-09	3.0E-09	Pass
Static Positive Mean Slope	16.40	54.9	-6.202E-11	-4.483E-10	4.440E-10	7.00E-10	8.289E-10	1.00E-10	9.289E-10	1.0E-09	Pass
Static Negative Mean Slope	33.90	-20.0	3.599E-11	3.808E-10	-3.791E-10	-7.00E-10	-7.961E-10	-1.00E-10	-8.961E-10	-1.0E-09	Pass
Gradient Positive Mean Slope	14.82	48.6	-1.873E-10	-7.968E-10	7.745E-10	1.00E-09	1.265E-09	1.00E-10	1.365E-09	2.0E-09	Pass
Gradient Negative Mean Slope	20.38	45.8	4.189E-10	8.706E-10	-7.632E-10	-1.00E-09	-1.258E-09	-1.00E-10	-1.358E-09	-2.0E-09	Pass

Summary

The EUT complies with clause A.2.4 of Cospas-Sarsat T.007.



2.11 SATELLITE QUALITATIVE TESTS

2.11.1 Specification

Cospas-Sarsat T.007, Clause A.2.5

2.11.2 Equipment Under Test and Modification State

Tron 40VDR S/N: 11975 - Modification State 0 (Configurations 5 and 7)
Tron 40VDR S/N: 11975 - Modification State 1 (Configuration 8)

2.11.3 Date of Test

21 – 22 February 2018, 13 – 14 June 2018, 06 – 07 December 2018

2.11.4 Test Equipment Used

The major items of test equipment used for the above tests are identified in Section 3.1.

2.11.5 Environmental Conditions

Ambient Temperature -0.4 – 27.1°C
Relative Humidity 36.3 – 74.3%



2.11.6 Test Results

Configuration 5

Test Start: 15:00 21/2/18
 Test End: 10:00 22/2/18
 15 Hex ID: 203C5 CDD8E FFBFF

Actual location of the test beacon: 50.814333
 (Daedalus Airfield, Lee-on-the-Solent, Central) -1.2017389

Satellite ID	Satellite Pass Number	15 Hex ID Provided by LUT	Doppler Latitude	Doppler Longitude	Mean Rx Power (dBm)	TCA	CTA (deg)	Location Error (km)
S10	65750	203C5 CDD8E FFBFF	50.81695	-1.19794	-121.39	20:32:59	-15.232	0.395
S11	58861	203C5 CDD8E FFBFF	50.81952	-1.19406	-128.17	22:55:46	-20.321	0.789
S13	28176	203C5 CDD8E FFBFF	50.81889	-1.19228	-131.96	22:12:21	-12.667	0.835
S11	58860	203C5 CDD8E FFBFF	50.82017	-1.19067	-125.63	21:14:30	-4.348	1.012
S13	28175	203C5 CDD8E FFBFF	50.81769	-1.20704	-128.20	20:31:49	3.058	0.527
S13	28174	203C5 CDD8E FFBFF	50.81614	-1.20223	-127.81	18:52:40	16.897	0.204
S7	2858	203C5 CDD8E FFBFF	50.82332	-1.19196	-131.60	20:04:05	-20.889	1.212
S11	58859	203C5 CDD8E FFBFF	50.82322	-1.21163	-125.37	19:34:42	10.638	1.207
S7	2857	203C5 CDD8E FFBFF	50.82336	-1.19462	-126.14	18:23:04	-4.960	1.121
S10	65748	203C5 CDD8E FFBFF	50.82643	-1.22419	-129.66	17:11:42	14.933	2.072
S7	2856	203C5 CDD8E FFBFF	50.82169	-1.21706	-127.10	16:43:32	10.036	1.351
S12	46587	203C5 CDD8E FFBFF	50.82162	-1.19179	-125.99	16:03:43	-8.807	1.069
S10	65757	203C5 CDD8E FFBFF	50.80688	-1.24409	-127.62	08:49:02	3.338	3.087
S13	28182	203C5 CDD8E FFBFF	50.80549	-1.20412	-134.52	08:43:15	-14.873	0.997
S7	2865	203C5 CDD8E FFBFF	50.80503	-1.20510	-126.94	08:12:31	8.139	1.060
S10	65756	203C5 CDD8E FFBFF	50.80045	-1.20835	-127.03	07:07:56	-12.399	1.611
S7	2864	203C5 CDD8E FFBFF	50.80526	-1.20624	-127.75	06:32:47	-7.081	1.057
S12	46595	203C5 CDD8E FFBFF	50.80991	-1.20096	-127.32	06:00:38	12.066	0.495
S12	46594	203C5 CDD8E FFBFF	50.81014	-1.21114	-126.35	04:20:24	-2.712	0.808
S12	46593	203C5 CDD8E FFBFF	50.80253	-1.20867	-129.74	02:38:41	-18.758	1.399

Location Errors greater than 5 km are marked in red text.

$$\begin{aligned}
 \text{Ratio of Successful Solutions} &= \frac{\text{number of Doppler solutions within 5 km with } 1^\circ < \text{CTA} < 21^\circ}{\text{number of satellite passes over test duration with } 1^\circ < \text{CTA} < 21^\circ} \\
 &= \frac{20}{20} \\
 &= 100\%
 \end{aligned}$$



Configuration 7

Test Start: 15:00 13/6/18
 Test End: 10:00 14/6/18
 15 Hex ID: 203C5 CDD8E FFBFF

Actual location of the test beacon: 50.814333
 (Daedalus Airfield, Lee-on-the-Solent, Central) -1.2017389

Satellite ID	Satellite Pass Number	15 Hex ID Provided by LUT	Doppler Latitude	Doppler Longitude	Mean Rx Power (dBm)	TCA	CTA (deg)	Location Error (km)
S11	60452	203C5 CDD8E FFBFF	50.81811	-1.19491	-130.70	22:35:05	-17.587	0.637
S13	29767	203C5 CDD8E FFBFF	50.82423	-1.19290	-136.62	21:54:00	-9.911	1.263
S11	60451	203C5 CDD8E FFBFF	50.82421	-1.17419	-128.85	20:54:04	-1.670	2.224
S10	67331	203C5 CDD8E FFBFF	50.82585	-1.19397	-131.44	20:34:36	-12.963	1.391
S13	29766	203C5 CDD8E FFBFF	50.82421	-1.21730	-133.82	20:13:43	5.626	1.549
S7	4454	203C5 CDD8E FFBFF	50.82469	-1.19028	-131.76	19:59:19	-19.070	1.404
S11	60450	203C5 CDD8E FFBFF	50.82015	-1.21619	-132.98	19:14:30	12.980	1.203
S10	67330	203C5 CDD8E FFBFF	50.81902	-1.23373	-130.34	18:53:27	2.852	2.306
S7	4453	203C5 CDD8E FFBFF	50.82962	-1.18209	-129.20	18:18:30	-3.168	2.188
S10	67329	203C5 CDD8E FFBFF	50.82611	-1.23744	-137.72	17:13:44	16.699	2.827
S7	4452	203C5 CDD8E FFBFF	50.82189	-1.21309	-134.56	16:39:07	11.615	1.158
S12	48168	203C5 CDD8E FFBFF	50.82288	-1.18995	-130.00	16:17:01	-8.548	1.260
S12	48167	203C5 CDD8E FFBFF	50.82297	-1.21402	-130.55	14:36:15	6.911	1.290
S10	67338	203C5 CDD8E FFBFF	50.73827	-0.99724	-124.94	08:50:53	1.397	16.672
S7	4461	203C5 CDD8E FFBFF	50.81130	-1.19467	-133.56	08:08:04	6.502	0.600
S10	67337	203C5 CDD8E FFBFF	50.80196	-1.20551	-136.37	07:09:34	-14.643	1.400
S7	4460	203C5 CDD8E FFBFF	50.80452	-1.20946	-131.27	06:28:11	-8.893	1.218
S12	48176	203C5 CDD8E FFBFF	50.81175	-1.20174	-132.24	06:13:55	11.822	0.287
S12	48175	203C5 CDD8E FFBFF	50.81094	-1.21345	-131.65	04:33:39	-2.994	0.905
S12	48174	203C5 CDD8E FFBFF	50.79064	-1.21202	-139.71	02:51:56	-19.047	2.730

Location Errors greater than 5 km are marked in red text.

$$\begin{aligned}
 \text{Ratio of Successful Solutions} &= \frac{\text{number of Doppler solutions within 5 km with } 1^\circ < \text{CTA} < 21^\circ}{\text{number of satellite passes over test duration with } 1^\circ < \text{CTA} < 21^\circ} \\
 &= \frac{19}{20} \\
 &= 95\%
 \end{aligned}$$



Configuration 8 (Modification State 1)

Test Start: 15:00 06/12/18
 Test End: 10:00 07/12/18
 15 Hex ID: 203C5 CDD8E FFBFF

Actual location of the test beacon: 50.868975
 (TUV SUD Ltd, Fareham Site, Central) -1.244737

Satellite ID	Satellite Pass Number	15 Hex ID Provided by LUT	Doppler Latitude	Doppler Longitude	Mean Rx Power (dBm)	TCA	CTA (deg)	Location Error (km)
S11	62910	203C5 CDD8E FFBFF	50.86467	-1.24522	-126.73	22:49:55	-20.845	0.465
S13	32225	203C5 CDD8E FFBFF	50.87748	-1.24056	-134.01	22:13:47	-13.194	1.006
S13	32224	203C5 CDD8E FFBFF	50.87403	-1.24851	-119.80	20:33:12	2.535	0.629
S13	32223	203C5 CDD8E FFBFF	50.87335	-1.25206	-125.20	18:54:01	16.443	0.708
S11	62909	203C5 CDD8E FFBFF	50.87577	-1.23444	-126.02	21:08:35	-4.891	1.063
S11	62908	203C5 CDD8E FFBFF	50.87171	-1.24826	-116.19	19:28:43	10.144	0.395
S10	69773	203C5 CDD8E FFBFF	50.88401	-1.23781	-126.12	20:26:55	-8.012	1.757
S7	6919	203C5 CDD8E FFBFF	50.88204	-1.23411	-130.19	19:22:18	-11.596	1.650
S10	69772	203C5 CDD8E FFBFF	50.88285	-1.26462	-127.85	18:46:12	7.378	2.081
S7	6918	203C5 CDD8E FFBFF	50.88326	-1.26029	-128.19	17:42:10	3.993	1.931
S10	69771	203C5 CDD8E FFBFF	50.86818	-1.27621	-131.16	17:06:54	20.239	2.197
S12	50610	203C5 CDD8E FFBFF	50.87618	-1.24327	-129.60	16:23:29	-5.721	0.822
S7	6917	203C5 CDD8E FFBFF	50.87548	-1.27318	-131.71	16:03:25	17.586	2.115
S11	62916	203C5 CDD8E FFBFF	50.86463	-1.24804	-125.48	09:20:26	-6.555	0.518
S7	6927	203C5 CDD8E FFBFF	50.85168	-1.22660	-128.61	09:10:53	13.850	2.300
S13	32231	203C5 CDD8E FFBFF	50.85714	-1.24981	-132.68	08:44:40	-14.415	1.346
S10	69779	203C5 CDD8E FFBFF	50.85097	-1.24521	-130.80	07:01:40	-19.567	1.987
S12	50618	203C5 CDD8E FFBFF	50.86525	-1.24170	-126.65	06:20:39	9.313	0.459
S7	6925	203C5 CDD8E FFBFF	50.85387	-1.24607	-129.46	05:51:09	-16.375	1.667
S12	50617	203C5 CDD8E FFBFF	50.87011	-1.25410	-128.49	04:40:08	-5.840	0.660

Location Errors greater than 5 km are marked in red text.

$$\begin{aligned}
 \text{Ratio of Successful Solutions} &= \frac{\text{number of Doppler solutions within 5 km with } 1^\circ < \text{CTA} < 21^\circ}{\text{number of satellite passes over test duration with } 1^\circ < \text{CTA} < 21^\circ} \\
 &= \frac{20}{20} \\
 &= 100\%
 \end{aligned}$$

Summary

The EUT complies with clause A.2.5 of Cospas-Sarsat T.007.



2.12 BEACON ANTENNA TEST (EIRP RECALCULATION ONLY)

2.12.1 Specification

Cospas-Sarsat T.007, Clause A.2.6

2.12.2 Equipment Under Test and Modification State

Not applicable

2.12.3 Date of Test (Recalculation)

20 November 2018

2.12.4 Test Equipment Used

Not applicable

2.12.5 Environmental Conditions

Not applicable

2.12.6 Test Results

The measurement data presented below has been taken from TUV report 75924802 Report 01, and has been adjusted as follows:

The ambient power in TUV report 75924802 for Modification State 0 was reported as 37.2dBm. The output power in this report in Modification State 1 was measured as 36.1dBm.

All raw EIRP measurements and the P_{ambient} figure have therefore been adjusted by $(37.2 - 36.1) = 1.1\text{dB}$.

P_{EOL} figure taken from TUV report 75924802 Report 01, Modification State 0.



Configuration 4 - EUT in Float-Free Housing

Azimuth Angle (Degrees)	Elevation Angle (degrees)									
	10		20		30		40		50	
	EIRP dBm	Ant dBi	EIRP dBm	Ant dBi	EIRP dBm	Ant dBi	EIRP dBm	Ant dBi	EIRP dBm	Ant dBi
0	37.7	1.59	38.7	2.60	38.6	2.54	33.8	-2.34	25.4	-10.69
90	37.5	1.42	38.8	2.70	39.1	2.99	35.1	-0.98	25.9	-10.25
180	38.1	2.02	38.9	2.84	37.8	1.74	32.8	-3.34	25.8	-10.31
270	37.3	1.17	39.3	3.24	38.0	1.94	33.8	-2.28	25.6	-10.54
$EIRP_{LOSS} = P_{t_{ambient}} - P_{t_{EOL}} = 36.1 - 37.37 = -1.27dBm$										
$EIRP_{maxEOL} = \text{Max}[EIRP_{max}, (EIRP_{max} - EIRP_{LOSS})] = \text{Max}[39.3, 40.6] = 40.6dBm$										
$EIRP_{minEOL} = \text{Min}[EIRP_{min}, (EIRP_{min} - EIRP_{LOSS})] = \text{Min}[32.8, 34.0] = 32.8dBm$										



Configuration 1 - EUT Stand Alone

Azimuth Angle (Degrees)	Elevation Angle (degrees)									
	10		20		30		40		50	
	EIRP dBm	Ant dBi	EIRP dBm	Ant dBi	EIRP dBm	Ant dBi	EIRP dBm	Ant dBi	EIRP dBm	Ant dBi
0	38.0	1.86	39.7	3.62	41.2	5.08	36.9	0.80	32.7	-3.37
30	37.0	0.92	39.3	3.19	40.7	4.62	36.5	0.44	32.8	-3.31
60	36.7	0.63	39.1	3.01	40.6	4.54	36.5	0.41	32.4	-3.68
90	36.6	0.48	39.0	2.92	40.6	4.50	36.4	0.30	32.1	-4.04
120	36.6	0.49	38.8	2.74	40.3	4.25	36.4	0.29	32.0	-4.14
150	36.7	0.63	38.9	2.80	40.3	4.24	36.4	0.30	32.4	-3.68
180	36.8	0.67	39.2	3.08	40.6	4.51	36.4	0.28	32.2	-3.87
210	37.3	1.16	39.6	3.47	40.8	4.68	36.6	0.47	32.4	-3.75
240	37.5	1.39	39.8	3.70	41.0	4.93	36.8	0.67	32.8	-3.26
270	37.5	1.42	40.1	3.96	41.3	5.18	37.2	1.05	33.0	-3.12
300	37.6	1.52	40.0	3.89	41.2	5.07	37.2	1.06	33.1	-3.01
330	37.6	1.46	40.0	3.86	41.1	5.00	36.9	0.83	33.2	-2.93

$EIRP_{LOSS} = P_{t_{ambient}} - P_{t_{EOL}} =$	36.1	-	37.37	=	-1.28dBm				
$EIRP_{maxEOL} = \text{Max}[EIRP_{max}, (EIRP_{max} - EIRP_{LOSS})] =$						Max[41.3,	42.6]= 42.6 dBm
$EIRP_{minEOL} = \text{Min}[EIRP_{min}, (EIRP_{min} - EIRP_{LOSS})] =$						Min[32.1,	33.3]= 32.1 dBm



Configuration 4 - EUT Stand Alone

Azimuth Angle (Degrees)	Elevation Angle (degrees)									
	10		20		30		40		50	
	EIRP dBm	Ant dBi	EIRP dBm	Ant dBi	EIRP dBm	Ant dBi	EIRP dBm	Ant dBi	EIRP dBm	Ant dBi
0	39.1	2.99	40.3	4.25	38.5	2.43	33.2	-2.90	22.3	-13.83
90	39.7	3.60	40.3	4.24	38.7	2.58	33.7	-2.42	23.5	-12.65
180	38.9	2.79	40.2	4.08	38.5	2.40	33.3	-2.76	22.2	-13.92
270	38.9	2.85	40.2	4.13	38.5	2.39	33.0	-3.07	20.6	-15.54
EIRP _{LOSS} = Pt _{ambient} - Pt _{EOL} =			36.1-	37.37	= -1.27dBm					
EIRP _{maxEOL} = Max[EIRP _{max} , (EIRP _{max} - EIRP _{LOSS})] =			Max[40.3,	41.6]= 41.6dBm			
EIRP _{minEOL} = Min[EIRP _{min} , (EIRP _{min} - EIRP _{LOSS})] =			Min[33.0,	34.3]= 33.0dBm			

Summary

The EUT complies with clause A.2.6 of Cospas-Sarsat T.007.



2.13 NAVIGATION SYSTEM TEST

2.13.1 Specification

Cospas-Sarsat T.007, Clause A.2.7

2.13.2 Equipment Under Test and Modification State

Tron 40VDR S/N: 11975 - Modification State 0

2.13.3 Date of Test

07 February 2018

2.13.4 Test Equipment Used

The major items of test equipment used for the above tests are identified in Section 3.1.

2.13.5 Environmental Conditions

Ambient Temperature 21.5°C

Relative Humidity 34.7%



2.13.6 Test Results

Standard Protocol

Position Data Default Values (C/S T.007 A.3.8.1):

No position data was provided for > 4 hours before the test started. The beacon was activated and operated for 30 minutes without providing data. Message content was checked for all bursts during this period.

36 Hex Message	Message Count
FF FED0901E2E6ECB7FDFFAD8BEF783E0F66C* FF FE2F901E2E6ECB7FDFFAD8BEF783E0F66C	37

* First message transmitted as Self-Test.

Position Acquisition Time and Position Accuracy (C/S T.007 A.3.8.2)

Locations:

A.3.8.2.1: N 50° 48.860' W 1° 12.104'

A.3.8.2.2: N 50° 52.121' W 1° 14.685' ①

The appropriate position was applied, the EUT activated and time to first message containing valid position data timed.

Configuration as per C/S T.007	C/S T.007 Section A.3.8.2.1		C/S T.007 Section A.3.8.2.2	
	Time to Acquire Position (sec)	Location Error in metres	Time to Acquire Position (sec)	Location Error in metres
Configuration 5	57	35.6	60	55.2
Configuration 7	59	35.6	57	24.2
Configuration 8 (Standalone)	57	35.6	58	24.2
Configuration 8 (fitted in Float Free case)	59	35.6	59	24.2

Positional accuracy was calculated using the Haversine Formula, The Earth's radius was taken as 6367 km.

① GPS Site Survey – Live Location



Encoded Position Data Update Interval (C/S T.007 A.3.8.3):

Location: N 50° 48.683' W 1° 37.417' ①		
Data Acquired at	12:13:43	FFFE2F901E2E6ECB32E033FB6C378EA76951
Location: N 51° 22.583' W 1° 49.833' ①		
Data Updated at	12:20:23	FFFE2F901E2E6ECB33A03C2FCD371DA4D4D0
Data Update Interval	6 min 40 s	

① Input from GPS simulator

* Note: Position 2 applied immediately after the first burst encoded with position 1.

Encoded Position Data Update Interval (C/S T.007 A.3.8.3) – Long Test:

Locations: N 0° 00.000' E 0° 00.000' (Start location). The position changes by 20km every 4m 55s, moving in a NE direction (045 bearing).		
Parameter	Update interval	Limit
0 h to 2 h – Minimum	05:47	≥ 05:00
0 h to 2 h – Maximum	11:50	≤ 30:00
2 h to 6 h – Minimum	05:40	≥ 05:00
2 h to 6 h – Maximum	06:41	≤ 30:00
6 h to 24 h – Minimum	05:37	≥ 05:00
6 h to 24 h – Maximum	06:31	≤ 60:00
Assessment	Result	Limit
Results indicate that data changes as per C/S T.001 4.5.5.4 (Y/N)	Y/N	Y
Results indicate that data changes as per manufacturer's update scheme (Y/N)	Y/N	Y

① Input from GPS simulator

Position Clearance After Deactivation (C/S T.007 A.3.8.4)

Following the Encoded Position Data Update Interval test, the beacon was deactivated and reactivated without providing navigation data. The Digital Message output was encoded with the default position data.

Position Data Input Update Interval (C/S T.007 A.3.8.5)

EUT does not accept external position input, test is not applicable.



Last Valid Position (C/S T.007 A.3.8.6)

Location: N 51° 22.583' W 1° 49.833' ①		
Data Acquired at	12:33:31	FFFE2F901E2E6ECB33A03C2FCD371DA4D4D0
GPS Signal Navigation Data Removed		
Data Updated at	16:33:44	FFFE2F901E2E6ECB7FDFFAD8BEF783E0F66C
Last Valid Position Held	240min 13s	
Return to Default Position	✓	

① Input from GPS simulator

Summary

The EUT complies with clause A.2.7 of Cospas-Sarsat T.007.



SECTION 3

TEST EQUIPMENT USED



3.1 TEST EQUIPMENT

List of absolute measuring and other principal items of test equipment.

Instrument	Manufacturer	Type No.	TE No.	Calibration Period (months)	Calibration Due
Section 2.1, 2.2, 2.3, 2.4, 2.6, 2.7 Beacons - Constant Temperature Tests					
Power Meter	Hewlett Packard	436A	47	12	03-Aug-2018
Climatic Chamber	Heraeus Votsch	VM 04/100	85	-	O/P Mon
Signal Generator	Hewlett Packard	8644A	199	12	27-Apr-2019
Attenuator: 10dB/20W	Narda	766-10	480	12	18-Dec-2018
Spectrum Analyser	Agilent Technologies	E7405A	1410	12	23-Aug-2018
Spectrum Analyser	Rohde & Schwarz	FSU26	2747	12	19-Feb-2019
Beacon RF Unit	TUV SUD	N/A	3066	-	TU
Attenuator (20dB, 10W)	Aeroflex / Weinschel	23-20-34	3159	12	21-Jun-2018
Attenuator (3dB, 20W)	Aeroflex / Weinschel	23-03-34	3163	12	20-Dec-2018
Bandpass Filter	Trilithic	5BE406/35-1-AA	3205	12	08-Jan-2019
Power Sensor	Agilent Technologies	8482A	3289	12	19-Apr-2019
Cable (2m, N Type)	Rhophase	NPS-1601-2000-NPS	3356	12	27-Jun-2018
Rubidium Frequency Standard	Symmetricom	8040C	3490	12	11-May-2019
Meter & T/C	R.S Components	Meter 615-8206 & Type K T/C	3612	12	12-Sep-2018
ScopeCorder	Yokogawa	DL750	4175	12	29-Jan-2019
Time Interval Analyser	Yokogawa	TA720	4550	12	14-Mar-2019
Bandpass Filter (1MHz)	KR Electronics	3219-SMA	4602	12	13-Jul-2018
Section 2.5 Beacons - Spurious Emissions					
Climatic Chamber	Heraeus Votsch	VM 04/100	85	-	O/P Mon
Rubidium Frequency Standard	Quartzlock	A10-B	92	12	27-Feb-2019
Spectrum Analyser	Rohde & Schwarz	FSU26	2747	12	19-Feb-2019
Attenuator (20dB, 10W)	Aeroflex / Weinschel	23-20-34	3160	12	02-Aug-2018
Attenuator (3dB, 20W)	Aeroflex / Weinschel	23-03-34	3163	12	20-Dec-2018
Bandpass filter	Trilithic	5BE406/35-1-AA	3206	12	13-Sep-2018
Meter & T/C	R.S Components	Meter 615-8206 & Type K T/C	3612	12	12-Sep-2018
1 metre N-Type Cable	Florida Labs	NMS-235SP-39.4-NMS	4510	12	14-Jun-2018
1 metre N-Type Cable	Florida Labs	NMS-235SP-39.4-NMS	4511	12	24-Apr-2019
Section 2.8 Beacons – Thermal Shock					
Power Meter	Hewlett Packard	436A	47	12	03-Aug-2018
Climatic Chamber	Heraeus Votsch	VMT 04/30	40	-	O/P Mon
Climatic Chamber	Heraeus Votsch	VM 04/100	85	-	O/P Mon
Signal Generator	Hewlett Packard	8644A	199	12	27-Apr-2019
Attenuator: 10dB/20W	Narda	766-10	480	12	18-Dec-2018



Spectrum Analyser	Agilent Technologies	E7405A	1410	12	23-Aug-2018
Spectrum Analyser	Rohde & Schwarz	FSU26	2747	12	19-Feb-2019
Beacon RF Unit	TUV SUD	N/A	3066	-	TU
Attenuator (20dB, 10W)	Aeroflex / Weinschel	23-20-34	3159	12	21-Jun-2018
Attenuator (3dB, 20W)	Aeroflex / Weinschel	23-03-34	3163	12	20-Dec-2018
Bandpass Filter	Trilithic	5BE406/35-1-AA	3205	12	08-Jan-2019
Power Sensor	Agilent Technologies	8482A	3289	12	19-Apr-2019
Cable (2m, N Type)	Rhophase	NPS-1601-2000-NPS	3356	12	27-Jun-2018
Rubidium Frequency Standard	Symmetricom	8040C	3490	12	11-May-2019
Meter & T/C	R.S Components	Meter 615-8206 & Type K T/C	3612	12	12-Sep-2018
ScopeCorder	Yokogawa	DL750	4175	12	29-Jan-2019
Time Interval Analyser	Yokogawa	TA720	4550	12	14-Mar-2019
Bandpass Filter (1MHz)	KR Electronics	3219-SMA	4602	12	13-Jul-2018
Section 2.10 Beacons – Temperature Gradient					
Power Meter	Hewlett Packard	436A	47	12	03-Aug-2018
Climatic Chamber	Heraeus Votsch	VM 04/100	85	-	O/P Mon
Signal Generator	Hewlett Packard	8644A	199	12	27-Apr-2019
Attenuator: 10dB/20W	Narda	766-10	480	12	18-Dec-2018
Spectrum Analyser	Agilent Technologies	E7405A	1410	12	23-Aug-2018
Spectrum Analyser	Rohde & Schwarz	FSU26	2747	12	19-Feb-2019
Beacon RF Unit	TUV SUD	N/A	3066	-	TU
Attenuator (20dB, 10W)	Aeroflex / Weinschel	23-20-34	3159	12	21-Jun-2018
Attenuator (3dB, 20W)	Aeroflex / Weinschel	23-03-34	3163	12	20-Dec-2018
Bandpass Filter	Trilithic	5BE406/35-1-AA	3205	12	08-Jan-2019
Power Sensor	Agilent Technologies	8482A	3289	12	19-Apr-2019
Cable (2m, N Type)	Rhophase	NPS-1601-2000-NPS	3356	12	27-Jun-2018
Rubidium Frequency Standard	Symmetricom	8040C	3490	12	11-May-2019
Meter & T/C	R.S Components	Meter 615-8206 & Type K T/C	3612	12	12-Sep-2018
ScopeCorder	Yokogawa	DL750	4175	12	29-Jan-2019
Time Interval Analyser	Yokogawa	TA720	4550	12	14-Mar-2019
Bandpass Filter (1MHz)	KR Electronics	3219-SMA	4602	12	13-Jul-2018
Section 2.13 Beacons - Navigation System					
Load (50ohm/30W)	Weinschel	50T-054	285	12	18-Sep-2018
Directional Coupler	Narda	3022	503	-	O/P Mon
Spectrum Analyser	Agilent Technologies	E7405A	1410	12	23-Aug-2018
Copper GRP	TUV SUD	27cm Diameter	3538	-	TU
1 metre N-Type Cable	Florida Labs	NMS-235SP-39.4-NMS	4509	12	14-Jun-2018
1 metre N-Type Cable	Florida Labs	NMS-235SP-39.4-NMS	4510	12	14-Jun-2018
1 - 18GHz DRG Antenna	ETS-Lindgren	3117	4738	12	17-Feb-2018



Non Conductive Standoff Box	TUV SUD	Non Conductive Standoff Box	4966	-	TU
Section 2.9 Beacons – Operating Lifetime (including Battery Current Measurements)					
0.25ohm resistor	R.S Components	188-071 x 2	3343	-	TU
Termination (50ohm)	Diamond Antenna	DL-30N	544	12	14-Feb-2018
Termination (50ohm)	Weinschel	50T-054	285	12	18-Sep-2018
Milliohmmeter	Hewlett Packard	4338B	2095	12	09-Jun-2018
Hygromer	Rotronic	I-1000	2829	12	29-Nov-2018
8 Channel Datalogger + Terminal Board	Pico Technology Ltd	ADC-16	3287	12	08-Jan-2019
Power Meter	Hewlett Packard	436A	83	12	26-Sep-2019
Climatic Chamber	Heraeus Votsch	VM 04/100	85	-	O/P Mon
Signal Generator	Hewlett Packard	8644A	199	10	27-Apr-2019
Load (50ohm/30W)	Weinschel	50T-054	285	12	15-Oct-2019
Termination (50ohm)	Meca	405-1	547	12	30-Jul-2019
Signal Generator	Marconi	2031	2015	12	29-Mar-2020
Attenuator (20dB, 10W)	Aeroflex / Weinschel	23-20-34	3158	12	4-Sep-2019
Attenuator (20dB, 10W)	Aeroflex / Weinschel	23-20-34	3159	12	23-Oct-2019
ScopeCorder	Yokogawa	DL750 701210	3254	12	12-Nov-2019
Meter & T/C	R.S Components	Meter 615-8206 & Type K T/C	3612	12	25-Sep-2019
GPS Antenna	ACC	PA175-S	4228	-	TU
Time Interval Analyser	Yokogawa	TA720	4550	12	18-Mar-2020
Bandpass Filter (1MHz)	KR Electronics	3219-SMA	4602	12	3-Sep-2019
2 metre N-Type Cable	Florida Labs	NMS-235SP-78.8-NMS	4622	12	10-Jul-2019
Cable (18 GHz)	Rosenberger	LU7-036-1000	5025	-	O/P Mon
Cable (18 GHz)	Rosenberger	LU7-036-1000	5027	-	O/P Mon
Cable (18GHz)	Rosenberger	LU7-036-2000	5038	-	O/P Mon
Section 2.11 Beacons - Satellite Qualitative Test					
Copper GRP	TUV SUD	27cm Diameter	3538	-	TU
Hygropalm Temperature and Humidity Meter	Rotronic	HP21	4410	12	24-May-2019
Non Conductive Standoff Box	TUV SUD	Non Conductive Standoff Box	4966	-	TU

Note: some tests took place over one or more days and consequently it may appear that some of the test equipment could have been outside of the valid calibration period at the time of testing. However, we confirm that all equipment held a valid and in-date calibration when used, and we hold this information on record.

TU – Traceability Unscheduled

OP MON – Output Monitored with Calibrated Equipment



SECTION 4

PHOTOGRAPHS

4.1 PHOTOGRAPHS OF EQUIPMENT UNDER TEST (EUT)



Test Configuration



Battery Current Measurements (Standalone)

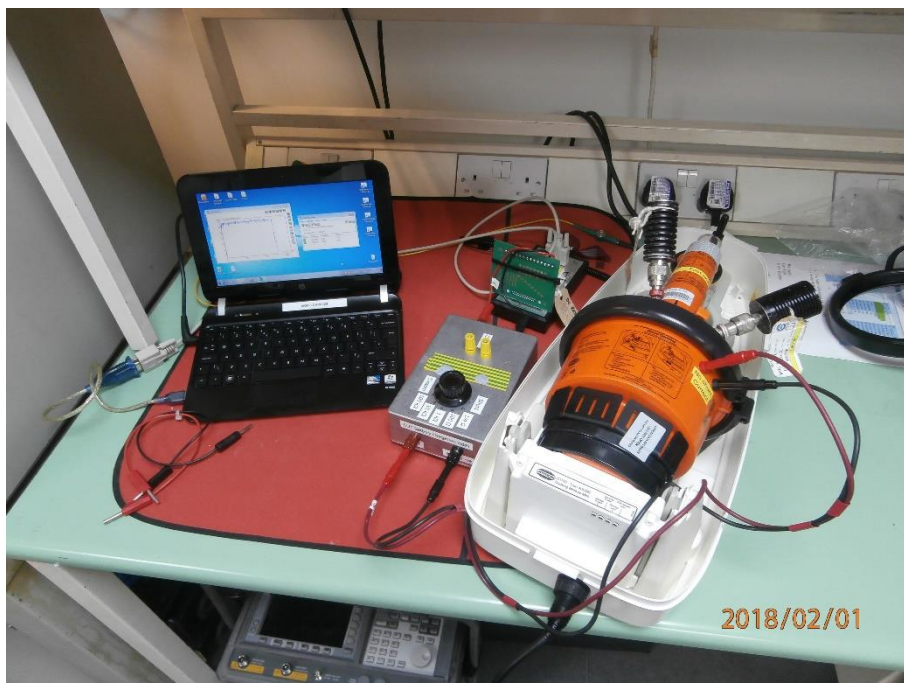

Battery Current Measurements (Float Free Case)

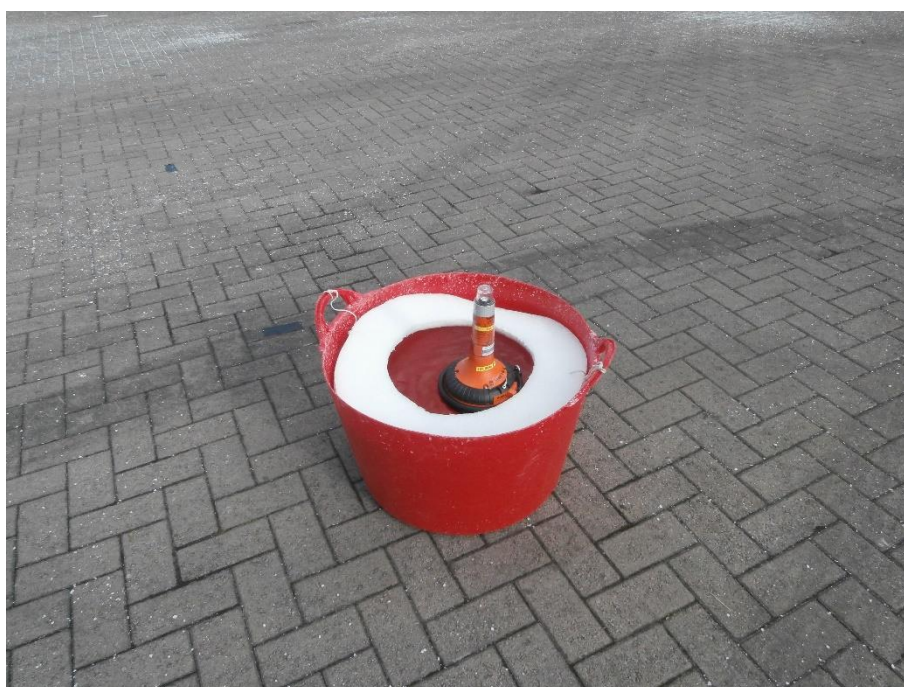

Satellite Qualitative / A.3.8.3 Test Configuration 5

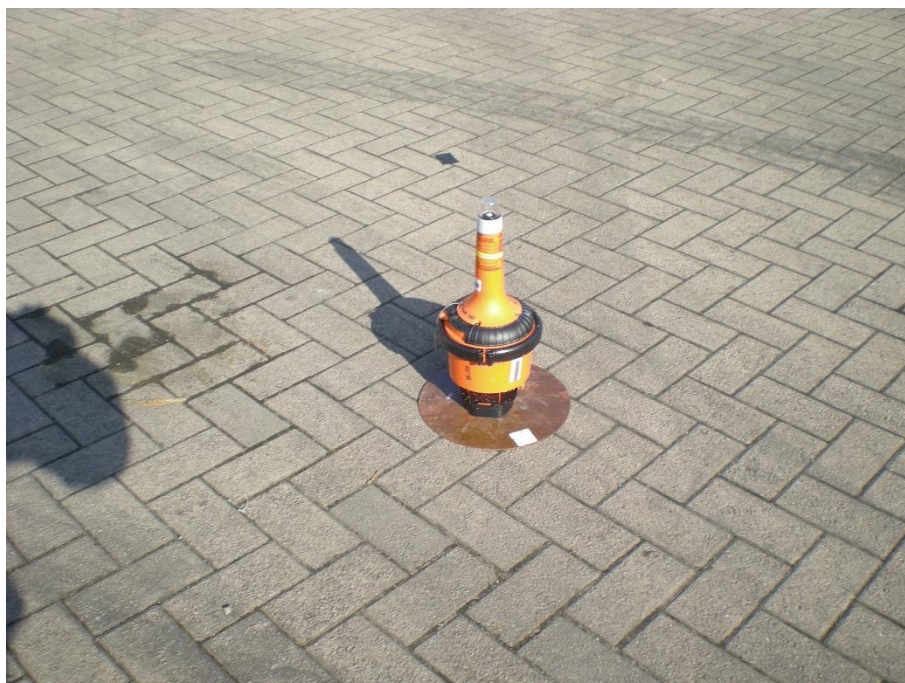

Satellite Qualitative / A.3.8.3 Configuration 7



A.3.8.3 Configuration 8 (Float Free Case)



Satellite Qualitative / A.3.8.3 Configuration 8 (Standalone)



SECTION 5

ACCREDITATION, DISCLAIMERS AND COPYRIGHT



5.1 ACCREDITATION, DISCLAIMERS AND COPYRIGHT



This report relates only to the actual item/items tested.

Our UKAS Accreditation does not cover opinions and interpretations and any expressed are outside the scope of our UKAS Accreditation.

Results of tests not covered by our UKAS Accreditation Schedule are marked NUA (Not UKAS Accredited).

This report must not be reproduced, except in its entirety, without the written permission of TÜV SÜD

© 2019 TÜV SÜD



ANNEX A

Manufacturer Supplied Information



Jotron AS
Jotron UK Ltd.
Jotron Phontech AS
Jotron Consultas AS
Jotron Asia Pte. Ltd.
Jotron USA, Inc.
UAB Jotron



Tron 40VDR

Loss in antenna matching network

Background:

Measuring of output power on 406MHz is done both in 50 ohm connector and radiated. The output power differs due to loss in antenna matching network. This network is bypassed on the unit with 50 ohm connector and therefore the measurements have to be corrected to match the radiated power.

This document describes the correction factor to subtract to the measurements done in the 50 ohm connector.

Reason:

D6 and FB4 have to be removed on the unit with connector, and with it also the antenna matching network and the output filter for the 121.5MHz transmitter. This leads to a higher output power in the connector than what reaches the antenna.

Scope:

This applies to the 406MHZ connector on Tron 40VDR.

Conclusion:

1.78dB has to be subtracted from the measurements done in the 50 ohm connector.

DNB Nor Bank ASA | 0021 Oslo | Norway | Bank account: 24400508514 | IBAN: NO6624400508514 | BIC: DNBANOKK | Reg.no.: NO917713324 MVA
QA Certificate: NS-EN ISO 9001:2008

www.jotron.com

Jotron AS
P.O. Box 54 | NO-3281 Tjodalving | Norway

Tel: +47 33 13 97 00
Fax: +47 33 12 67 80

	Additional description	0749
	Tron 40S/GPS MkII	Page 5 ^L (6 ^L)

4 Parameter 13 - Protection against continuous transmission

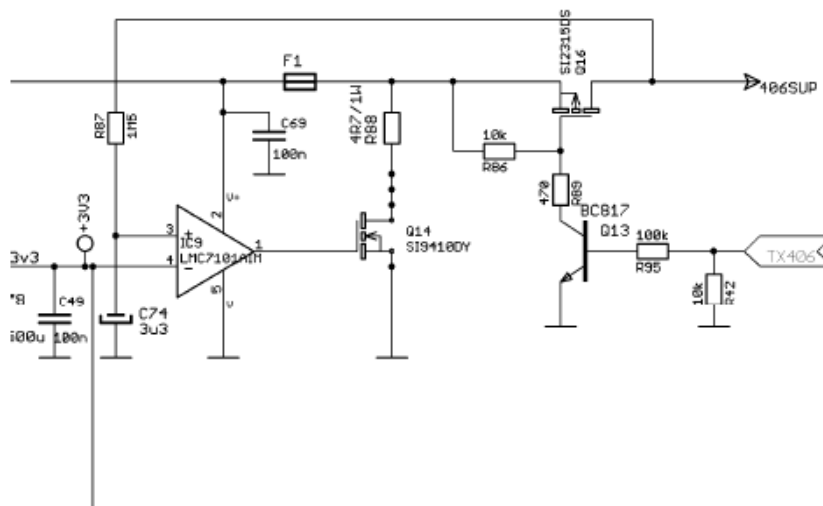

Figure 4

Please take a look at figure 4. If a continuous transmission occur, C74 will charge trough R87. When the voltage on IC9 pin 3 is higher than 3.3 V the output (#1) on IC 9 will go high, Q14 will conduct, and a 1.5 A current will destroy the fuse, F1. The 406SUP voltage is not longer present and will prevent the 406 transmitter.

5



Jotron AS
Jotron UK Ltd.
Jotron Phosphate AS
Jotron Computers AS
Jotron Asia Pte. Ltd.
Jotron USA, Inc.
UMB Jotron



Tron 40VDR

Protection against erroneous position encoding into the beacon message

Tron 40VDR uses the GPS module MAX-7 / NEO-7 from u-blox of Switzerland.

The RMC messages are used for position update.

Only messages with status flag 'A' (Active) and with the correct checksum are used.
Valid means 2D or 3D fix.

Øyvind L. Eggen
R&D Manager GMDSS & AIS



Jotron AS
Jotron UK Ltd.
Jotron Phontech AS
Jotron Consultas AS
Jotron Asia Pte. Ltd.
Jotron USA, Inc.
UAB Jotron



Tron 40VDR

Protection From Repetitive Self-Test Mode Transmissions

In self-test, the beacon is powered by a separate test switch, and a TEST signal will activate the self-test routine. After the microcontroller has performed the self-test routine, the microcontroller turns off all electrical circuits. Then the program runs in a wait loop until the TEST switch is released. Please see figure below.

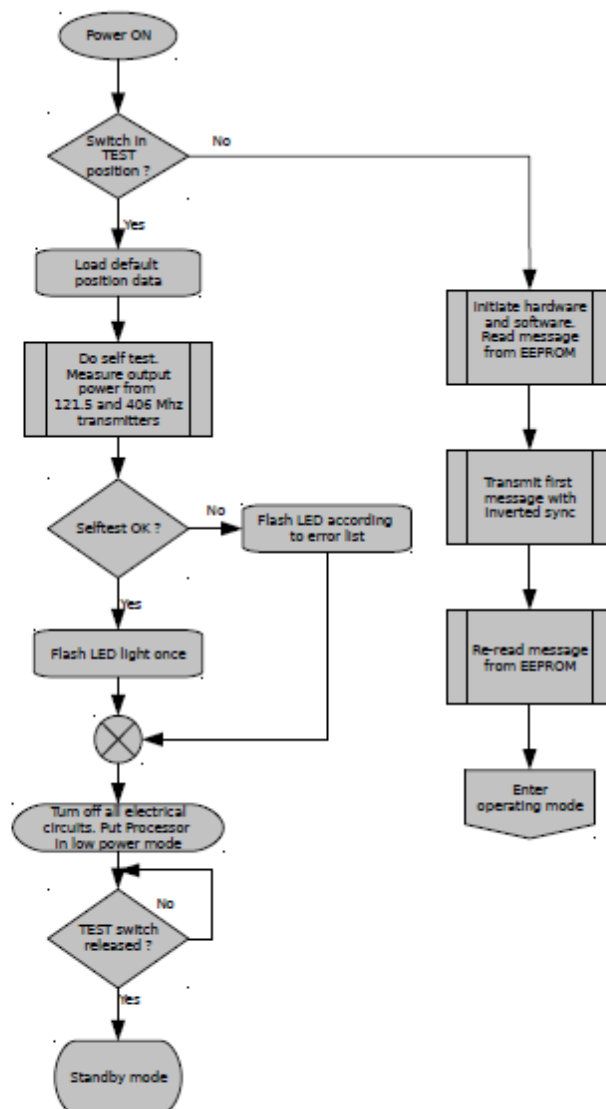

Figure 1: Self-Test flowchart

February 25 2014

Page 1 of 2



Jotron AS
Jotron UK Ltd.
Jotron Phontech AS
Jotron Consultas AS
Jotron Asia Pte. Ltd.
Jotron USA, Inc.
UAB Jotron



Tron 40VDR

GNSS Self-Test limited in number

GNSS Self-Test is activated by moving the switch to TEST-position twice within 3 seconds and released back to READY position. If more than allowed GNSS Self-Test's is already executed, this will be announced by 10 beep's and the EPIRB will power off.

If more GNSS Self-Test's is allowed, the counter is increased, a 120 seconds timer is started and the GNSS is switched on. If position is received before the timer stops, then a normal Self-Test is executed and the position is transmitted in the 406 message. The EPIRB power's off. In case of no position within the time limit, this will be announced by 5 beep's and the EPIRB will power off.

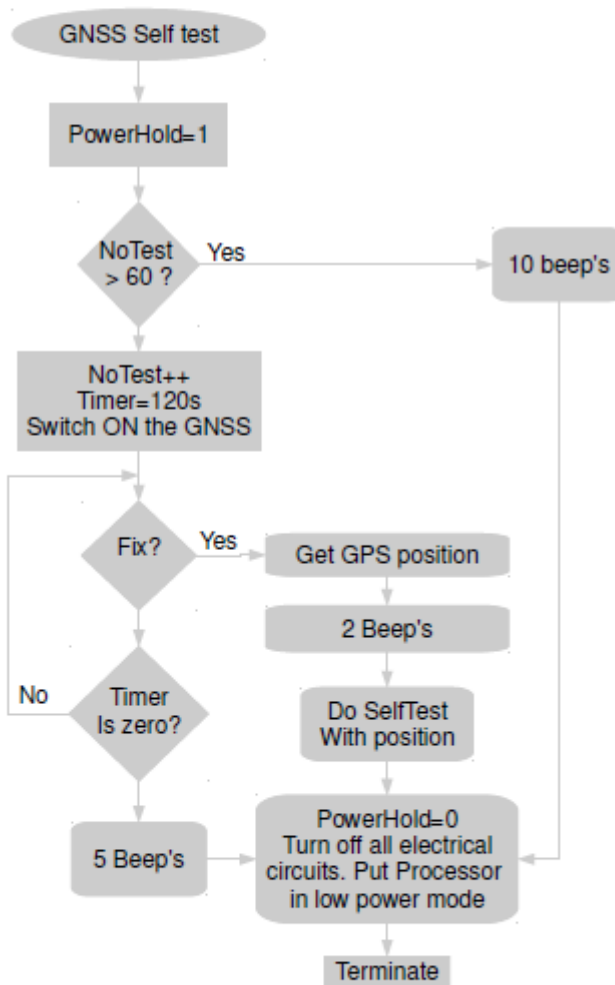

Figure 2: GNSS Self-Test flow chart



TEST REPORT



Rev.Date 2015-08-12	Rev. 1.0	Document ID X-87910-201504CHN-01
Prepared by Richard Haydon	Approved by Øyvind Eggen	
TRON40VDR Position Data Encoding		

CONFIDENTIAL

Test facility: Jotron AS. development laboratory
Østbyeveien 1, NO-3280 Tjodalyng
Norway

Report on: Jotron TRON40VDR

Manufacturer Representative: Øyvind Eggen,
Manager, Maritime, Energy, Communication Division
Phone: +47 45 666 911

Prepared by: Richard Anthony Haydon
Development Engineer, Maritime, Energy, Communication Division
Phone: +4748026223

Approved by: Jotron authorised signatory

Name: *Øyvind Eggen* Date: *Aug 13th 2015*

Date of Issue: August 2015

Dates of testing: Start: 6th August 2015
End: 6th August 2015



TEST REPORT

Rev. Date 2015-08-12	Rev. 1.0	Document ID X-87910-201504CHN-01
TRON40VDR Position Data Encoding		

Revision History

Revision	Date of Issue	Reason
1.0	August 2015	Original

1. Scope

The Jotron TRON40VDR is subject to a change of the navigational device used. This requires a change notice application to the COSPAS-SARSAT type approval certificate effective for this model, namely TAC185.

Case reference 2015-04 has been assigned to this change notice application and this report provides results in support of the application and is to accompany Ref [2].

The tests presented within this report are limited to the Position Data Encoding test as specified in A.3.8.7 of Ref [1] for the Standard Location Protocol.

2. Referenced Documents

[1] CS-T-007-Oct-2014 Issue 4 – Revision 9 October 2014

[2] 75928407 Report 01 Issue3

TEST REPORT

Rev. Date 2015-08-12	Rev. 1.0	Document ID X-87910-201504CHN-01
TRON40VDR Position Data Encoding		

3. Details of Test sample

Manufacturer	Jotron AS
Model name	TRON40VDR
Beacon Hardware P/N	X-87910
Beacon model PCB P/N and version	X-87454, R140
Samples in test	1
Serial number of test beacon	02704
Beacon Software P/N	X-87934
Software version	2.1.1 Oct 22-2014
Navigation device type	Internal
Known non-compliances with C/S T,001 requirements	No

The EUT is modified such that the serial interface from the microcontroller (uC) to the GPS module is disconnected. The uC serial interface is made available for use by external equipment with a six-pin inline connector, see Figure 1. The EUT was operated using its own power source (internal battery).



Figure 1 EUT Navigational input serial connection

TEST REPORT

Rev. Date 2015-08-12	Rev. 1.0	Document ID X-87910-201504CHN-01
TRON40VDR Position Data Encoding		

For the testing presented in this report the serial interface to the uC is connected to a PC which generates location information locations specified in Ref. [1] for the Position Data Encoding Test Standard Location protocol.

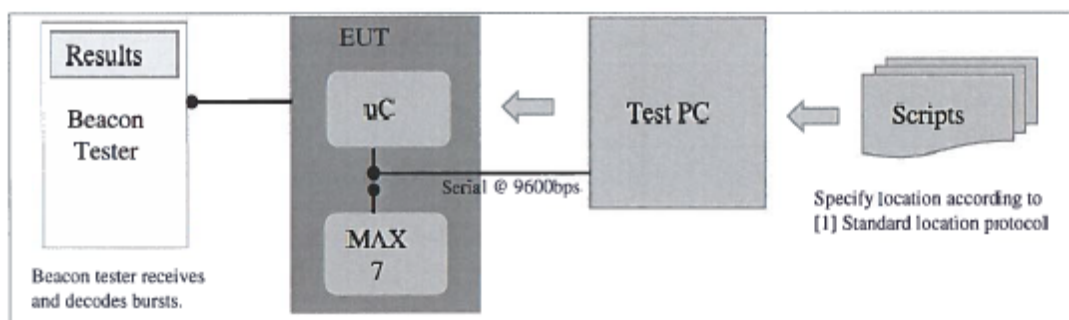

Figure 2 Test configuration block diagram

- **List of ancillary devices:**
None
- **List of test equipment**

Beacon Tester	Manufacturer	WS Technologies
	Model	BT100S
	S/N	5450
	Calibrated	06/2015
Test harness host PC*	Generic Win7 PC, Dell Precision	
Scripting SW	Jotron GPS sim software version 0.2	

*The test PC runs an application developed by Jotron AS which takes position information from a script file and generates NMEA GPS sentences from these. The sentences are sent to the EUT via the PC serial interface at 1Hz, that same rate as supplied by the EUT GPS unit.



TEST REPORT

Rev. Date 2015-08-12	Rev. 1.0	Document ID X-87910-201504CHN-01
TRON40VDR Position Data Encoding		

4. Type approval testing

Applied C/S Standards

Document	Issue	Revision	Date
C/S T.001	3	15	Oct2014
C/S T.007	4	9	Oct2014

Modes of Operation

Off / Standby Mode	Main switch set to OFF position
Operating	Main switch set to ON position
Self-Test	Main switch set to TEST position and held for 15 seconds

Modifications

Mod State	Date	Reason	Description
0	Prior to start of testing	Facilitate T.007 Position Data Encoding tests	<ul style="list-style-type: none"> - Serial interface from uC to internal GPS module is re routed from uC to external test harness. - Antenna port modified for connection to 50ohm impedance output

Statements

Non compliances noted during testing	None
Deviations from test procedure	None
Modifications	Modification 0 – No Modifications were made to the test sample during testing



TEST REPORT

Rev. Date 2015-08-12	Rev. 1.0	Document ID X-87910-201504CHN-01
TRON40VDR Position Data Encoding		

5. Test Results

5.1 Test Results Summary Table

N/A

5.2 Electrical and Functional Tests

N/A

5.3 Thermal shock test

N/A

5.4 Operating Lifetime test

N/A

5.5 Temperature Gradient Test

N/A

5.6 Oscillator Ageing (if applicable)

N/A

5.7 Antenna Characteristics

N/A

5.8 Beacon Coding Software

N/A



TEST REPORT

Rev. Date 2015-08-12	Rev. 1.0	Document ID X-87910-201504CHN-01
TRON40VDR Position Data Encoding		

5.9 Navigation System Test

Date of test	6 August 2015
Specification	Ref [1] Position Data Encoding test for the Standard Location Protocol
Beacon model	TRON40VDR
EUT Mod State	0
EUT system configuration during the test, including antenna, external ancillary devices and modes of their operation	Figure 2 shows the configuration under test. The operational mode is modified as specified by the test procedure during the course of testing.
Navigation device details (model, interface)	uBlox MAX-7Q-0. The interface is disconnected. Navigational input is sourced from the test harness described in this report.
Measurement Equipment, provided by beacon manufacturer, if any	WS Technologies Beacon Tester model BT100S, S/N 5450. Scripted input of navigational data to the EUT as described in this report.
Performed by	Richard Haydon, Jotron AS
Verified by	Øyvind Eggen, Jotron AS
Environmental conditions	Ambient
Deviations from standard test procedures	None
Non-compliances noticed	None

A brief description of actions messages and decodes during performance of the tests follows.

The results are recorded in the table within section 5.9.7 of this report.



TEST REPORT

Rev. Date 2015-08-12	Rev. 1.0	Document ID X-87910-201504CHN-01
TRON40VDR Position Data Encoding		

Table D.2 Script 1.

The beacon is turned ON. No navigational input is provided to the beacon after power on. The first burst is captured and decoded by the beacon tester. The bit fields forming the test result and the BCH validity are recorded.

Reading from Beacon tester (hex)	Bits 65-85 (hex)	Bits 113-32(hex)	BCH correct
FFFD090262E4A907FDFFC7A7E7783E0F66C	0FFBFF	83E0F	YES

As an example the full decode of the burst as rendered by the COSPAR-SARSAT online is shown below.

ITU List of MFD Country Code Numbers:

ITEM	BITS	VALUE
Message format: long format	25	1
Protocol: Location Protocol	26	0
Country code: 238 - Norway	27-36	0100000010
Type of location protocol: Standard Location - EPIRB (Senal)	37-40	0110
Cospas-Sarsat # 185	41-50	0010111001
Serial Number: 2704	51-64	00101010010000
Latitude Sign: default	65	0
Latitude Degrees: default	66-72	1111111
Latitude Minutes: default	73-74	11
Longitude Sign: default	75	0
Longitude Degrees: default	76-83	11111111
Longitude Minutes: default	84-85	11
BCH 1 Encoded	86-106	100011110100111111001
BCH 1 Calculated	N/A	100011110100111111001
Field bits (1101): Pass	107-110	1101
Position Data: Encoded Position Data Source From Internal Navigation Device	111	1
Air Device: 121.5 MHz homer	112	1
Latitude Offset Sign: default	113	1
Latitude Offset Minutes: default	114-118	00000
Latitude Offset Seconds: default	119-122	1111
Longitude Offset Sign: default	123	1
Longitude Offset Minutes: default	124-128	00000
Longitude Offset Seconds: default	129-132	1111
BCH 2 Encoded	133-144	011001101100
BCH 2 Calculated	N/A	011001101100
Composite Latitude: default	N/A	Composite Longitude: default
15 Hex ID	N/A	204C5C9520FFBFF



TEST REPORT

Rev. Date 2015-08-12	Rev. 1.0	Document ID X-87910-201504CHN-01
TRON40VDR Position Data Encoding		

Table D.2 script 2:

The beacon remains powered on. We start the test harness to supply navigational data according to this script and record the time using the clock on the host PC as a reference. Time recorded as 08:17:00.

The first burst is recorded and the time on the PC clock noted. 31 seconds elapsed between starting the navigational input and receiving the next burst at 08:17:31

Reading from Beacon tester (hex)	Bits 65-85 (hex)	Bits 113-32(hex)	BCH correct
FFFE2F90262E4A908020050A6E378420EDF0	100400	8420E	YES

Table D.2 script 3:

The beacon and test harness remain on and running. The script number used by the test harness is increased to that for this test item.

The beacon tester captured the next changed burst as follows:

Reading from Beacon tester (hex)	Bits 65-85 (hex)	Bits 113-32(hex)	BCH correct
FFFE2F90262E4A90000000323F378360D373	000000	8360D	YES

Table D.2 script 4:

The beacon and test harness remain on and running. The script number used by the test harness is increased to that for this test item.

The beacon tester captured the next changed burst as follows:

Reading from Beacon tester (hex)	Bits 65-85 (hex)	Bits 113-32(hex)	BCH correct
FFFE2F 90262E4A900056796B84370F2220AE	000ACF	0F222	YES



TEST REPORT

Rev. Date 2015-08-12	Rev. 1.0	Document ID X-87910-201504CHN-01
TRON40VDR Position Data Encoding		

Table D.2 script 5:

The beacon and test harness remain on and running. The script number used by the test harness is increased to that for this test item.

The beacon tester captured the next changed burst as follows:

Reading from Beacon tester (hex)	Bits 65-85 (hex)	Bits 113-32(hex)	BCH correct
FFFE2F90262E4A90009672FC4BB793A602AA	0012CE	93A60	YES

Table D.2 script 6:

The beacon and test harness remain on and running. The script number used by the test harness is increased to that for this test item.

The beacon tester captured the next changed burst as follows:

Reading from Beacon tester (hex)	Bits 65-85 (hex)	Bits 113-32(hex)	BCH correct
FFFE2F90262E4A9080767C53D5370FA10C2D	100ECF	0FA10	YES

Table D.2 script 7:

The beacon and test harness remain on and running. The script number used by the test harness is increased to that for this test item.

The beacon tester captured the next changed burst as follows:

Reading from Beacon tester (hex)	Bits 65-85 (hex)	Bits 113-32(hex)	BCH correct
FFFE2F90262E4A90D94B25A427F780A00F76	1B2964	80A00	YES

Table D.2 script 8:

The beacon and test harness remain on and running. The script number used by the test harness is increased to that for this test item.

The beacon tester captured the next changed burst as follows:

Reading from Beacon tester (hex)	Bits 65-85 (hex)	Bits 113-32(hex)	BCH correct
FFFE2F90262E4A90D96B218F52F784E007A2	1B2D64	84E00	YES



TEST REPORT

Rev. Date 2015-08-12	Rev. 1.0	Document ID X-87910-201504CHN-01
TRON40VDR Position Data Encoding		

Table D.2 script 9:

The beacon and test harness remain on and running. The script number used by the test harness is increased to that for this test item.

The beacon tester captured the next changed burst as follows:

Reading from Beacon tester (hex)	Bits 65-85 (hex)	Bits 113-32(hex)	BCH correct
FFFE2F90262E4A905A3683139837038016F7	0B46D0	03801	YES

Table D.2 script 10:

The beacon and test harness remain on and running. The script number used by the test harness is increased to that for this test item.

The beacon tester captured the next changed burst as follows:

Reading from Beacon tester (hex)	Bits 65-85 (hex)	Bits 113-32(hex)	BCH correct
FFFE2F90262E4A905A168738ED37080098C0	0B42D0	08009	YES

Table D.2 script 11:

The beacon and test harness remain on and running. The script number used by the test harness is increased to that for this test item.

The beacon tester captured the next changed burst as follows:

Reading from Beacon tester (hex)	Bits 65-85 (hex)	Bits 113-32(hex)	BCH correct
FFFE2F90262E4A90A4B1545AD8B78020001B	14962A	80200	YES



TEST REPORT

Rev. Date 2015-08-12	Rev. 1.0	Document ID X-87910-201504CHN-01
TRON40VDR Position Data Encoding		

Table D.2 script 12:

The beacon is turned off and the test harness supplying navigational input stopped.
Self test is initiated and the first burst captured by the beacon tester was recorded as:

Reading from Beacon tester (hex)	Bits 65-85 (hex)	Bits 113-32(hex)	BCH correct
FFFE2F90262E4A907FDFFC7A7E7783E0F66C	0FFBFF	83E0F	YES

Table D.2 script 13:

The beacon is turned off and the test harness supplying navigational input started with the values for this script number.

Self test is initiated and the first burst captured by the beacon tester was recorded as

Reading from Beacon tester (hex)	Bits 65-85 (hex)	Bits 113-32(hex)	BCH correct
FFFE2F90262E4A907FDFFC7A7E7783E0F66C	0FFBFF	83E0F	YES



TEST REPORT

Rev. Date 2015-08-12	Rev. 1.0	Document ID X-87910-201504CHN-01
TRON40VDR Position Data Encoding		

- 5.9.1 Position Data Default values
N/A

- 5.9.2 Position Acquisition Time and Position Accuracy Test (PAT-PAT)
N/A

- 5.9.3 Encoded Position Data Update Interval
N/A

- 5.9.4 Position Clearance After Deactivation
N/A

- 5.9.5 Position Data Input Update Interval
N/A

- 5.9.6 Last Valid Position
N/A



TEST REPORT

Rev. Date 2015-08-12	Rev. 1.0	Document ID X-87910-201504CHN-01
TRON40VDR Position Data Encoding		

5.9.7 Position Data Encoding Results

Table F-C.2: Position Data Encoding Results Standard Location Protocol

Script Reference (See Table D.2)	Value of Encoded Location Bits Transmitted by Beacon	Confirmation that BCH Correct (√)
1	Bits 65-85=0FFHFF Bits 113-132=83E0F	√
2	Bits 65-85=100400 Bits 113-132= 8420E Number of seconds after providing navigation data that beacon transmitted the above encoded location information: 31s	√
3	Bits 65-85=00000C Bits 113-132= 8361D	√
4	Bits 65-85=000ACF Bits 113-132= 0F222	√
5	Bits 65-85=0012CE Bits 113-132= 93A00	√
6	Bits 65-85= 100ECF Bits 113-132= 0FA10	√
7	Bits 65-85= 1B2964 Bits 113-132= 80A00	√
8	Bits 65-85= 1B2D64 Bits 113-132= 84E00	√
9	Bits 65-85=0B46E0 Bits 113-132= 03861	√
10	Bits 65-85=0B42D0 Bits 113-132= 08009	√
11	Bits 65-85= 14962A Bits 113-132= 80200	√
12	Bits 65-85= 0FFBFF Bits 113-132= 83E0F	√
13	Bits 65-85= 0FFBFF Bits 113-132= 83E0F	√



TEST REPORT

Rev. Date 2015-08-12	Rev. 1.0	Document ID X-87910-201504CHN-01
TRON40VDR Position Data Encoding		

6. Photographs

Figure 1 EUT Navigational input serial connection shows the actual EUT modified for navigational input from the test harness.

7. Test Equipment

Figure 2 of this report shows a block diagram of the EUT in the test environment used to produce the results listed. The test equipment used is detailed in section 3, List Of Test Equipment within this report.

8. Other technical information, which is referred to in the test report

Technical information relevant to the TRON40VDR is supplied in [2]

9. Technical data submitted by Beacon manufacturer

Appendix F to Annex F accompanies this report and references the Check List of Technical Data submitted by the manufacturer of the beacon.

END OF REPORT



F - 1

C/S T.007 – Issue 4 – Rev. 9
October 2014

APPENDIX G TO ANNEX F

Jotron as

Report on

Cospas-Sarsat 406 MHz Emergency Beacon Testing of the Jotron AS Tron 40VDR in accordance with C/S
T.007

Report Nr. 87910_181126 – Issue 1 19 November 2018



TRON40VDR
Beacon encoding
Software test

F - 2

C/S T.007 – Issue 4 – Rev. 9
October 2014

Jotron as
Innlaget 230
NO-3195 Skoppum
Norway

Report on: T.007 A.2.8 Beacon Coding Software

Prepared for: Jotron as.
PO Box 23
NO3195 Skoppum
Norway.

Prepared by:

Mads le Maire, Dev engineer.

Approved by:

Per Kolbjørn Soglo, R&D Director GMDSS & AIS

Date of Issue: 04 December 2018

Dates of testing: 18 November 2018

History of the report Issue/revisions:

Report Nr – Issue Nr. or Revision Nr.	Date of Issue	Reasons for re-issue
87910_181126 Issue 1	20180412	First edition



TRON40VDR
Beacon encoding
Software test

F - 3

C/S T.007 – Issue 4 – Rev. 9
October 2014

Section	Contents
1.	Scope
2.	References
3.	Details of Test Samples
4.	Type Approval Testing
5.	Beacon Coding Software



1 Scope

This test report addresses the T.007 clause A.2.8 Beacon Coding Software. The purpose is to show the Tron 40VDR is compliant with the requirements. According to clause A.2.8, this test can be conducted by the beacon manufacturer, and verified by the test laboratory for inclusion in the final test report.

2 Reference Documents

Cospas-Sarsat T.007 Issue 5 - May 2017 clause A.2.8

3 Details of Test samples

Manufacturer	Jotron AS
Model name	TRON 40VDR
Beacon hardware P/N	87910
Beacon model PCB P/N and version	X-87454, R1726
Samples in test	1
Serial number of beacon	11977
Beacon Software P/N	X-87934
Software version	SW ver 2.1.3, May 12 2017
Navigation device type	Internal
Known non-compliances with C/S T.001 requirements	None

For this test it is required to receive the 406 MHz signals from the EPIRB by the test equipment, however it must be ensured that the signals will not reach the Cospas-Sarsat satellite segment. To achieve this the following is done:

- The antenna of the EPIRB unit is detached, and the output signal from the transmitter is connected to a BNC connector mounted specially on this test unit
- The Power amplifier of the 406MHz signal is bypassed, limiting the output power to: -18.5 dBm.

For all other aspects the EPIRB will function as normal.

List of test equipment:

EPIRB Beacon tester	Manufacturer	Jotron AS
	Model	Tron Unidec
	S/N	200BB00425
	Calibrated	12-20 (expiry date)
EPIRB Beacon tester Software	Tron Unidec EPIRB decoder ver 3.3.9	

The test equipment consists of a Jotron Unidec EPIRB tester with accompanying software which run on a generic PC with windows 7 operating system:

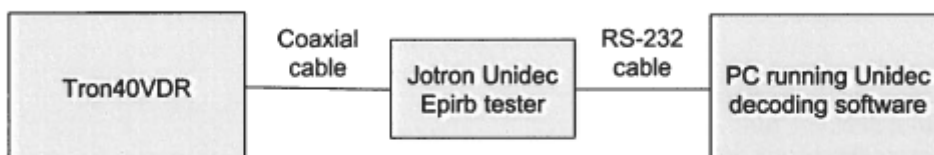

Figure 1. Test configuration block diagram

4 Type approval testing

Applied C/S standards:

Document	Issue	Revision	Date
C/S T.001	4	1	May 2017
C/S T.007	5	-	May 2017

Modes of Operation:

Off /Standby Mode	Main switch set to OFF position
Operating	Main switch set to ON position
Self-Test	Main switch set to TEST position and held for 15 seconds before released to OFF position.

Modifications:

Mod State	Date	Reason	Description
0	Prior to start of testing	Facilitate T.007 Beacon coding software test.	Transmitter PA by-passed. The RF signal is fed to an external 50 ohm connector. The power level is -18.5 dbm.

Statements:

Non compliances noted during testing	None
Deviation from test procedure	None
Modification	No modification was made to the test sample during testing.



5 Test Results

5.1 Test results summary table: N/A

5.2 Electrical and Functional tests: N/A

5.3 Thermal check test: N/A

5.4 Operating lifetime test: N/A

5.5 Temperature gradient test: N/A

5.6 Oscillator aging: N/A

5.7 Antenna characteristics: N/A

5.8 Beacon coding software:

Date of test	18 November 2018
Specification	Cospas-Sarsat T.007, clause A 2.8
Beacon Model	Tron 40VDR S/N 11977
EUT Mod State	Modification 0
Performed by	Mads le Maire
Verified by	Arnt Løke
Measurement Equipment, provided by beacon manufacturer	Tron Unidec 406 MHz EPIRB tester.
Reference documents	Cospas-Sarsat T.007
Environmental conditions:	Ambient Temperature 22° C
Deviations from standard test procedures	None
Non-compliances noticed	None



TRON40VDR
Beacon encoding
Software test

F - 7

C/S T.007 – Issue 4 – Rev. 9
October 2014

Record and report:

Protocol	Operational Message in hexadecimal including bit and frame synchronisation bits)		Self-Test Message (in hexadecimal including bit and frame synchronisation bits)	GNSS Self Test Message (if applicable, in hexadecimal, including bit and frame synchronisation bits)
	Location A	Location B		
Standard Location: EPIRB with MMSI	FFFE2F90121E240F3B8152 AB8CF71D46621B	FFFE2F90121E240F3B8152 AB8CF71C453480	FFFED090121E240F7FDFF 87697F783E0F66C	FFFED090121E240F3B8152 AB8CF71D46621B
Standard Location: EPIRB with Serial Number	FFFE2F90162E6EC93B8155 E6CF771D46621B	FFFE2F90162E6EC93B8155 E6CF771C453480	FFFED090162E6EC97FDFFF 3BD47783E0F66C	FFFED090162E6EC93B8155 E6CF771D46621B
Standard Location: Test	FFFED0901E2E6EC93B8154 4935F71D46621B	FFFE2F901E2E6EC93B8154 4935F71C453480	FFFED0901E2E6EC97FDFFE 942EF783E0F66C	FFFED0901E2E6EC93B81544 935F71D46621B

Position A: N 59.37777777777778 E 10.393333333333334
Position B: N 59.382222222222225 E 10.413333333333332
Approx. Distance between location A and location B: approx. 1200 meters.

5.9 Navigation System test: N/A

6 Photographs



Picture 1. The EUT under test attached to the Unidec tester.



Picture 2. Decoded message shown in the Jotron Unidec PC program.



7 Test Equipment

Figure 1 of this report shows a block diagram of the EUT in the test environment used to produce the results listed. The test equipment used is detailed in section 3, List of Equipment within this report.

8 Other technical information, which is referred to in the test report:

Technical information relevant to the TRON40VDR is supplied in [2]

9 Technical data submitted by Beacon manufacturer

Appendix F to Annex F accompanies this report and references the check list of technical data submitted by the manufacturer of the beacon.