



Product Service

**Choose certainty.
Add value.**

Report On

Emergency Beacons Limited Testing of the
Jotron AS
Tron 40VDR
In accordance with Cospas-Sarsat T.007

Document 75924802 Report 01 Issue 4

July 2014



Product Service

TÜV SÜD Product Service, Octagon House, Concorde Way, Segensworth North,
Fareham, Hampshire, United Kingdom, PO15 5RL
Tel: +44 (0) 1489 558100. Website: www.tuv-sud.co.uk

REPORT ON

Emergency Beacons Limited Testing of the
Jotron AS
Tron 40VDR

Document 75924802 Report 01 Issue 4

July 2014

PREPARED FOR

Jotron AS
Østbyveien 1
3280 Tjodalyng
Norway

PREPARED BY

A handwritten signature in black ink, appearing to read 'M. Hardy'.

Martin Hardy
Engineer

APPROVED BY

A handwritten signature in blue ink, appearing to read 'R. Hampton'.

Robert Hampton
Authorised Signatory

DATED

16 July 2014





Product Service

CONTENTS

Section	Page No
1	REPORT SUMMARY 3
1.1	Introduction 4
1.2	Application Form 5
1.3	Product Information 11
1.4	Modifications 15
1.5	Report Modification Record 15
2	TEST DETAILS 16
2.1	Digital Message 26
2.2	Modulation 30
2.3	Spurious Emission into 50 Ohms 34
2.4	406 MHz VSWR Check 36
2.5	Self-test Modes 40
2.6	Operating Lifetime at Minimum Temperature 48
2.7	Satellite Qualitative Tests 68
2.8	Beacon Antenna Test 72
2.9	Beacon Coding Software 76
2.10	Navigation System Test 78
3	TEST EQUIPMENT USED 82
3.1	Test Equipment 83
4	PHOTOGRAPHS 85
4.1	Photographs of Equipment Under Test (EUT) 86
5	ACCREDITATION, DISCLAIMERS AND COPYRIGHT 91
5.1	Accreditation, Disclaimers and Copyright 92
ANNEX A	Customer Supplied Information A.2



Product Service

SECTION 1

REPORT SUMMARY

Emergency Beacons Limited Testing of the
Jotron AS
Tron 40VDR



Product Service

1.1 INTRODUCTION

The information contained in this report is intended to show verification of the Emergency Beacon Limited Testing of the Jotron AS Tron 40VDR to the requirements of Cospas-Sarsat T.007.

Objective	To perform Emergency Beacon Testing to determine the Equipment Under Test's (EUT's) compliance with the Test Specification, for the series of tests carried out.
Manufacturer	Jotron AS
Model Number(s)	Tron 40VDR
Serial Number(s)	S/N00075 (TUV Ref: 75924802-TSR0001) S/N00001 (TUV Ref: 75924802-TSR0003)
Number of Samples Tested	2
Test Specification/Issue/Date	Cospas-Sarsat T.007 Issue 4 - Rev 8 October 2013
Incoming Release Date	Application Form 06 December 2013
Date of Receipt of Test Samples	25 November 2013
Order Number Date	XL1346003 15 November 2013
Start of Test	15 November 2013
Finish of Test	12 July 2014
Name of Engineer(s)	M Hardy A Guy
Related Documents	Cospas-Sarsat T.001 Issue 3 - Rev 14 October 2013 Cospas-Sarsat T.008 Issue 2 - Rev 1 November 2005



Product Service

1.2 APPLICATION FORM

Beacon Manufacturer and Beacon Model

Beacon Manufacturer	Jotron AS
Beacon Model	Tron 40VDR
Other Model Names	

Beacon Type and Operational Configurations

Beacon Type	Beacon used while:	Tick where appropriate
EPIRB	Floating in water or on deck or in a safety raft	<input checked="" type="checkbox"/>
PLB	On ground and above ground	<input type="checkbox"/>
	On ground and above ground and floating in water	<input type="checkbox"/>
ELT Survival	On ground and above ground	<input type="checkbox"/>
	On ground and above ground and floating in water	<input type="checkbox"/>
ELT Auto Fixed	Fixed ELT with aircraft external antenna	<input type="checkbox"/>
ELT Auto Portable	In aircraft with an external antenna	<input type="checkbox"/>
	On ground, above ground, or in a safety raft with an integrated antenna	<input type="checkbox"/>
ELT Auto Deployable	Deployable ELT with attached antenna	<input type="checkbox"/>
Other (specify)		<input type="checkbox"/>

Beacon Characteristics

Characteristic	Specification
Operating frequency	406,037 MHz
Operating temperature range	Tmin = -20 °C Tmax = +55 °C
Operating lifetime	168 hours
Beacon power supply type (internal, external, combined, other)	internal
External power supply parameters (AC/DC and nominal voltages)	
Is external power supply needed to energise the beacon or its ancillary devices in any of operation modes (N/A or Yes or No)	



Characteristic	Specification
Battery cell chemistry	Lithium-thionyl chloride (Li-SOCI ₂)
Battery cell model name, size and number of cells in a battery pack, and details of the battery pack electrical configuration	LSH14 light, C-size, 10cells, 5 batteries in parallel each with 2 cells in serial.
Battery cell manufacturer	SAFT
Battery pack manufacturer and part number	Jotron AS, X-87457
Beacon manufacturers declared maximum allowed cell shelf-life (from date of cell manufacture to date of battery pack installation in the beacon)	1.5 years
Declared beacon battery replacement period (from date of installation in the beacon to expiry date marked on the beacon)	5 years
Oscillator type (e.g. OCXO, MCXO, TCXO)	TCXO
Oscillator manufacturer	RAKON
Oscillator part name and number	E4520LF
Oscillator satisfies long-term frequency stability requirements (Yes or No)	Yes
Antenna type: Integral or Other (e.g. External, Detachable – specify type)	Integral
Antenna manufacturer	Jotron AS
Antenna part name and number	X-83053
Navigation device type (Internal, External or None)	Internal
Features in beacon that prevent degradation to 406 MHz signal or beacon lifetime resulting from a failure of navigation device or failure to acquire position data (Yes, No, or N/A)	Yes
Features in beacon that ensures erroneous position data is not encoded into the beacon message (Yes, No or N/A)	Yes
Navigation device capable of supporting global coverage (Yes, No or N/A)	Yes
Encoded position update capability (Yes, No, N/A) and	Yes
Encoded position update interval value (range)	6-16 min
For Internal Navigation Devices	
- Geodetic reference system (WGS 84 or GTRF)	WGS 84
- GNSS receiver cold start forced at every beacon activation (Yes or No)	Yes
- Navigation device manufacturer	Fastrax
- Navigation device model name and part Number	iTrax IT500
- Internal navigation device antenna type (integrated, internal, external, passive/active), manufacturer and model	Internal, Allis Comm. GPS-P1P
- GNSS system supported (e.g. GPS, GLONASS, Galileo)	GPS
For External Navigation Devices	
- Data protocol for GNSS receiver to beacon interface	
- Physical interface for beacon to navigation device	
- Electrical interface for beacon to navigation device	
- Part number of the external navigation interface device (if applicable)	
- Navigation device model and manufacturer (if beacon designed to use specific devices)	



Characteristic	Specification	
Self-Test Mode Characteristics	Self-Test Mode	Optional GNSS Self-Test Mode
- Activated by a separate switch/ separate switch position (Yes or No)	Yes	No
- Self-test/GNSS self-test mode switch automatically returns to normal position when released (Yes or No)	Yes	Yes
- Self-test/ GNSS self-test activation can cause an operational mode transmission (Yes or No)	No	No
- Results in transmission of a single self-test burst only, regardless of how long the self-test activation mechanism is applied (Yes or No)	Yes	Yes
- Results of self-test/ GNSS self-test are indicated by (provide details, e.g. Pass / Fail indicator light, strobe light, etc.)	Number of strobe light flashes. One=OK	Number of strobe light flashes. One=OK
- The content of the encoded position data fields of the self-test message has default values	Yes	N/A
- Performs an internal check and indicates that RF-power is being emitted at 406 MHz and 121.5 MHz, if beacon includes a 121.5 Hz homer (Yes or No)	Yes	Yes
- Self-test results in transmission of a signal other than at 406 MHz (Yes & details or No)	Yes, 121.5MHz	Yes, 121.5MHz
- Self-test can be activated directly at beacon (Yes or No)	Yes	Yes
- List of Items checked by self-test	Supported in product manuals	Supported in product manuals
- Self-test/ GNSS self-test 406 MHz burst duration (440 or 520 ms)	520ms	520ms
- Self-test message length format flag in bit 25, ("0" or "1")	1	1
- Maximum duration of a self-test mode, sec	13 sec. if OK and no GNSS test	130 sec. for GNSS and 6sec. for self-test
- Maximum recommended number of self-tests during battery pack replacement period	60	N/A
- Distinct indication of self-test start (Yes or No)	No	Yes
- Indication of self-test results(Yes or No)	Yes	Yes
- Distinct indication of insufficient battery capacity (Yes or No)	No	No
- Automatic termination of self-test mode immediately after completion of the self-test cycle (Yes or No)	Yes	Yes
- Maximum number of GNSS Self Tests (beacons with internal navigation devices only)	N/A	60
- GNSS Self-test results in transmission of a single burst, irrespectively of the test result (Yes or No)	N/A	No
- Maximum number of self-tests during battery pack replacement period	60	N/A
- Self-test/ GNSS self-test can be activated from beacon remote activation points (Yes & details or No)	No	No
- List all methods of Self-test mode and GNSS Self-test modes activation. Provide details on a separate sheet to describe	Move and hold switch in TEST position for 15 sec.	Move switch to TEST position twice within 3 sec. and release.



Characteristic	Specification	
Message Coding Protocols:	(x) Tick the boxes below against the intended protocol options	
User Protocol (tick where appropriate)	<input type="checkbox"/> Maritime with MMSI	
	<input type="checkbox"/> Maritime with Radio Call Sign	
	<input type="checkbox"/> EPIRB Float Free with Serial Number	
	<input type="checkbox"/> EPIRB Non Float Free with Serial Number	
	<input type="checkbox"/> Radio Call Sign	
	<input type="checkbox"/> Aviation	
	<input type="checkbox"/> ELT with Serial Number	
	<input type="checkbox"/> ELT with Aircraft Operator and Serial Number	
	<input type="checkbox"/> ELT with Aircraft 24-bit Address	
	<input type="checkbox"/> PLB with Serial Number	
	<input type="checkbox"/> National (Short Message Format)	
	<input type="checkbox"/> National (Long Message Format)	
	Standard Location Protocol (tick where appropriate)	<input checked="" type="checkbox"/> EPIRB with MMSI
		<input checked="" type="checkbox"/> EPIRB with Serial Number
<input type="checkbox"/> ELT with 24-bit Address		
<input type="checkbox"/> ELT with Aircraft Operator Designator		
<input type="checkbox"/> ELT with Serial Number		
<input type="checkbox"/> PLB with Serial Number		
National Location Protocol (tick where appropriate)	<input type="checkbox"/> National Location: EPIRB	
	<input type="checkbox"/> National Location: ELT	
	<input type="checkbox"/> National Location: PLB	
RLS Location Protocol (tick where appropriate)	<input type="checkbox"/> EPIRB	
	<input type="checkbox"/> ELT	
	<input type="checkbox"/> PLB	
User Location Protocol (tick where appropriate)	<input type="checkbox"/> Maritime with MMSI	
	<input type="checkbox"/> Maritime with Radio Call Sign	
	<input type="checkbox"/> EPIRB Float Free with Serial Number	
	<input type="checkbox"/> EPIRB Non Float Free with Serial Number	
	<input type="checkbox"/> Radio Call Sign	
	<input type="checkbox"/> Aviation	
	<input type="checkbox"/> ELT with Serial Number	
	<input type="checkbox"/> ELT with Aircraft Operator and Serial Number	
	<input type="checkbox"/> ELT with Aircraft 24-bit Address	
	<input type="checkbox"/> PLB with Serial Number	



Product Service

Characteristic	Specification
Beacon includes a homer transmitter(s) (Yes or No)	Yes
- homer transmitter(s) frequency	121.5 MHz
- homer transmitter(s) power	17 +/- 3 dBm
- homer transmitter(s) duty cycle	96 %
- duty cycle of homer swept tone	37 %
Beacon transmission repetition period satisfies C/S T.001 requirement that two beacon's repetition periods are not synchronised closer than a few seconds over 5 minute period, and the time intervals between transmissions are randomly distributed on the interval 47.5 to 52.5 seconds (Yes or No)	Yes
Other ancillary devices (e.g. voice transceiver, remote control, external audio and light indicators, external activation device). List details on a separate sheet if insufficient space to describe.	No
Beacon includes automatic activation mechanism (Yes or No) Specify type of automatic beacon activation mechanism	Yes
Beacon includes software or hardware features and functions not listed above and non-related to 406 MHz (Yes or No) List features and use a separate sheet if insufficient space	Yes. VDR storage module. See details in document Add_VDR_functionality_to_Tron40GPS-4.pdf
Beacon model hardware part number (P/N) and version	X-87910
Beacon model software/firmware P/N and version, date of issue/releases	X-87934, 2.00
Beacon model printed circuit board P/N and version	X-87454, 1341
Beacon Manufacturer Point of Contact (POC) for this Type Approval application:	Name and Job Title: Øyvind Eggen, R&D Manager GMDSS & AIS Phone: +4733083418 E-mail: oyvind.eggen@jotron.com

Dated 13 March 2014 Signed: *Øyvind Eggen, R&D Manager GMDSS & AIS*
(Name, Position and Signature of Beacon Manufacturer Representative)



Product Service

Information Provided by the Cospas-Sarsat Accepted Test Facility

Name and Location of Beacon Test Facility: TÜV SÜD Product Service, United Kingdom

Date of Submission for Testing: November 2013

Applicable C/S Standards:

Document	Issue	Revision	Date
C/S T.001	3	14	Oct-13
C/S T.007	4	8	Oct-13

I hereby confirm that the 406 MHz beacon described above has been successfully tested in accordance with the Cospas-Sarsat 406 MHz Beacon Type Approval Standard (C/S T.007) and complies with the Specification for Cospas-Sarsat 406 MHz Distress Beacons (C/S T.001) as demonstrated in the attached report.

Detail any observed non-compliances and/or deviations from standard test procedures here:

- Section 2.2, Modulation – Test Facility Accuracy (as per C/S T.008) added to modulation phase deviation limits
- Section 2.4, VSWR – Test Facility Accuracy (as per C/S T.008) added to modulation phase deviation limits
- Section 2.5 , Self-test – Non-compliance; distinct indication of RF emission not provided

Signed:

Name:

Robert Hampton

Position Held:

Authorised Signatory

Date:

16 July 2014

1.3 PRODUCT INFORMATION

1.3.1 Technical Description

The Equipment Under Test (EUT) was a Jotron AS Tron 40VDR as shown in the photograph below. A full technical description can be found in the manufacturer's documentation.



Equipment Under Test with VDR module

1.3.2 Physical Test Configuration

The Equipment Under Test (EUT) was operated using its own power source (internal battery). One EUT was configured so that the antenna port was connected to the 50 Ω test system using a coaxial cable. The test configuration for all tests is identical with the exception of Antenna Characteristics, Satellite Qualitative and Position Accuracy Time and Position Accuracy. This EUT was modified to allow a 50 Ω impedance output. To achieve this, the manufacturer bypassed a matching network integral to the EUT. This resulted in a higher output power that required correcting in accordance with the manufacturers data supplied in Annex A.

The second EUT was a fully packaged beacon, similar to the proposed production beacons equipped with its proper antenna. This EUT was used to perform Antenna Characteristics, Satellite Qualitative and Position Acquisition Time and Position Accuracy. The test configuration for these tests is a function of the beacon type and the operational environments supported by the beacon, as declared by the manufacturer.

For all tests (unless otherwise stated), the EUT was configured with the VDR module fitted to the base of the EUT. To enable data to be sent to the VDR module, the EUT was fitted into a Float Free Case (Docking Module, as shown in the setup information shown below. (Information is transferred to the VDR module via the Float Free case). Measurements for Satellite Qualitative, Antenna Characteristics and Position Accuracy Time and Position Accuracy were repeated with the EUT in 'Stand Alone' configuration as shown in the photographs in Section 4 of this report.

The test time interval was extended and consecutive 406 bursts were measured over 35 minutes for the following tests:

- Transmitter power output
- Digital message
- Digital message generator
- Modulation
- 406 MHz transmitted frequency
- 406 MHz VSWR check

This was to ensure that measurements were made during the operating modes described in section 1.3.3. The manufacturer advised that after the first burst from switch on, the GPS receiver operates in the following duty cycle: On for 2 minutes, Off for 6 minutes, On for 2 minutes, Off for 7* minutes... (in the absence of a GPS signal). A test time of 35 minutes includes at least 4 cycles of the GPS receiver operation.

* The Off time increments by 1 minute each cycle, up to a maximum of 16 minutes.

System Configuration

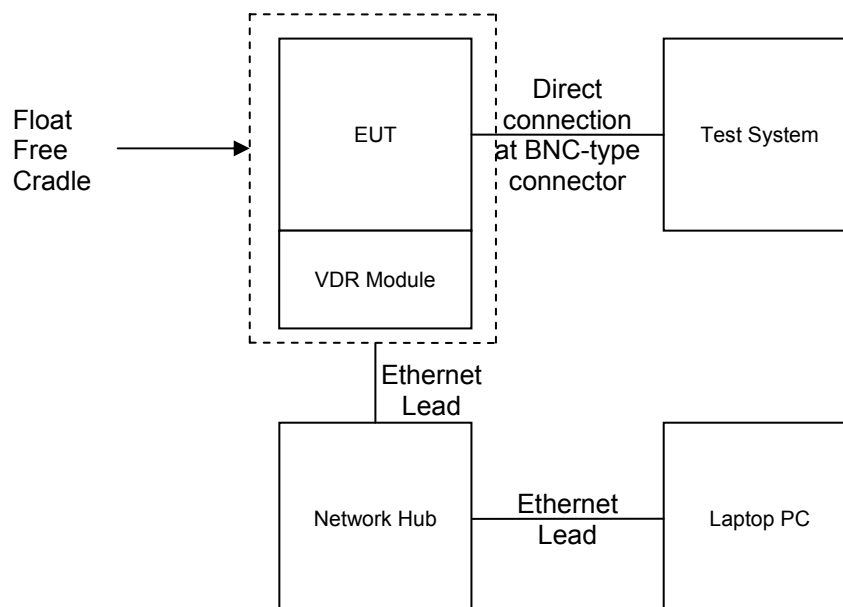



EUT with VDR module and Float Free case



Product Service

1.3.3 Modes of Operation

Modes of operation of the EUT during testing were as follows:

Off/Standby Mode

- Main switch to “OFF” position

Self-test

- Main Switch to “TEST” position (hold for 15 seconds)
- List of items checked as per Customer Supplied Information (Application Form)
- Additional Information supplied in Annex A

GNSS Self-test

- Main Switch to “TEST” position (twice in 3 seconds)
- List of items checked as per Customer Supplied Information (Application Form)
- Navigation data applied as applicable (e.g. none applied for timeout, data applied for ‘fast acquisition’)
- Additional Information supplied in Annex A

Operating

- Main switch to “ON” position
- 121 Homer active and offset
- GPS operating in normal duty cycle
- Physical configuration as below

All modes

All mode descriptions are applicable to all tests unless otherwise stated. Additional methods of activation include:

- Water contacts

All Navigation input descriptions are applicable to all tests unless otherwise stated.



Product Service

1.4 MODIFICATIONS

Modification 0 – As supplied by manufacturer

Modification 1 – Modification fitted by customer to reduce phase noise and ripple for Modulation tests. Details of the modification can be found in Annex A.

1.5 REPORT MODIFICATION RECORD

Issue 1 – First Issue

Issue 2 – To amend specification versions.

Issue 3 – Self test details clarified in the summary table in section. Section 1.3.2 revised to clarify setup conditions. Electrical tests repeated in Modification State 1 (MS1) with extended test interval. Battery current measurements repeated in MS1 for comparison to MS0

Issue 4 – Electrical Tests repeated with extended test interval to include all test modes. Additional information added to summary table/ test results section and 'Physical Test Configuration' section.



Product Service

SECTION 2

TEST DETAILS

Emergency Beacons Limited Testing of the
Jotron AS
Tron 40VDR



Product Service

TEST RESULTS TABLE

Parameters to be Measured	Range of Specification	Units	Test Results			Comments	
			Tmin	Tamb	Tmax		
			(-20 °C)	(+21 °C)	(+55 °C)		
1. Power Output							
Model: Tron 40VDR, S/N: 00001, TUV Ref: TSR3 and Modification State 1							
Transmitter power output (max / min)	35 – 39	dBm	38.5 / 38.45	37.97 / 37.86	38.51 / 38.28	Power results figures include 1.78 dB deduction due to antenna matching network (see manufacturer information, Annex A)	
Power output rise time (max / min)	< 5	ms	0.03 / 0.02	0.04 / 0.03	0.04 / 0.03		
Power output 1ms before burst (max / min)	< -10	dBm	-34.17 / -39.2	-31.62 / -37.12	-33.34 / -38.3		
2. Digital Message Coding							
Model: Tron 40VDR, S/N: 00001, TUV Ref: TSR3 and Modification State 1							
Bit Sync	1 - 15	15 bits "1"	P / F	P	P	P	
Frame sync	16 - 24	"000101111"	P / F	P	P	P	
Format flag	25	1 bit	bit value	1	1	1	
Protocol flag	26	1 bit	bit value	0	0	0	
Identification / position data	27 - 85	59 bits	P / F	P	P	P	
BCH code	86 -106	21 bits	P / F	P	P	P	
Emerg. Code/nat. use/supplem. Data	107 - 112	6 bits	bit value	110111	110111	110111	
Additional data / BCH (if applicable)	112 - 144	32 bits	P / F	P	P	P	
Position Error (if applicable)		< 5	km	N/A	N/A	N/A	



Product Service

Parameters to be Measured	Range of Specification	Units	Test Results			Comments
			Tmin	Tamb	Tmax	
			(-20 °C)	(+21 °C)	(+55 °C)	
3. Digital Message Generator						Result: Pass
Model: Tron 40VDR, S/N: 00001, TUV Ref: TSR3 and Modification State 1						
Repetition rate, T _R :						
Average T _R	48.5 ≤ T _{Ravg} ≤ 51.5	seconds	50.43	49.74	49.858	
Minimum T _R	47.5 ≤ T _{Rmin} ≤ 48.0	seconds	47.64	47.68	47.547	
Maximum T _R	52.0 ≤ T _{Rmax} ≤ 52.5	seconds	52.42	52.50	52.453	
Standard deviation	0.5 - 2.0	seconds	1.82	1.92	1.74	
Bit rate						
Minimum fb	≥ 396	bits/sec	399.704	399.705	399.706	
Maximum fb	≤ 404	bits/sec	399.714	399.715	399.713	
Total transmission time						
Short message	435.6 - 444.4	ms	N/A	N/A	N/A	
Long message (max / min)	514.8 - 525.2	ms	519.989 / 519.988	519.993 / 519.986	519.993 / 519.990	
Unmodulated carrier (max / min)						
Minimum T1	≥ 158.4	ms	160.636	160.636	160.637	
Maximum T1	≤ 161.6	ms	160.674	160.679	160.677	
First burst delay	≥ 47.5	seconds	55	55	55	
4. Modulation						Result: Non-Compliance (See Comment)
Model: Tron 40VDR, S/N: 00001, TUV Ref: TSR3 and Modification State 1						
Biphase-L	P / F	P / F	P	P	P	
Rise time (max/min)	50 - 250	μs	146.4 / 142.3	146.4 / 143.3	146.4 / 142.3	
Fall time (max/min)	50 - 250	μs	147.7 / 142.6	146.7 / 141.6	146.7 / 142.7	
Phase deviation: positive (max/min)	+(1.0 to 1.2)	radians	1.1884 / 1.0324	1.2070* / 1.0181	1.1612 / 1.0414	* Phase Deviation outside of spec limits, however the results are inside the limits when expanded by the Test facility Accuracy requirement stated in C/S T.008
Phase deviation: negative (max/min)	-(1.0 to 1.2)	radians	-1.1766 / -1.0167	-1.1905 / -1.0337	-1.1743 / -1.0046	
Symmetry measurement	≤ 0.05		0.0263	0.0248	0.0255	



Product Service

Parameters to be Measured	Range of Specification	Units	Test Results			Comments
			Tmin	Tamb	Tmax	
			(-20 °C)	(+21 °C)	(+55 °C)	
5. 406 MHz Transmitted Frequency						
Model: Tron 40VDR, S/N: 00001, TUV Ref: TSR3 and Modification State 1						
Nominal Value (max / min)	C/S T.001	MHz	406.0369366 / 406.0369362	406.0369141 / 406.0369138	406.0369067 / 406.0369062	
Short-term stability (max / min)	$\leq 2 \times 10^{-9}$	/100ms	1.18×10^{-10} / 6.13×10^{-11}	1.59×10^{-10} / 1.14×10^{-10}	1.42×10^{-10} / 1.06×10^{-10}	
Medium-term stability – Slope (max / min)	$(-1 \text{ to } +1) \times 10^{-9}$	/minutes	8.42×10^{-11} / 2.48×10^{-12}	5.01×10^{-11} / 3.65×10^{-12}	1.64×10^{-10} / 2.64×10^{-11}	
Medium-term stability – Residual frequency variation (max / min)	$\leq 3 \times 10^{-9}$		2.64×10^{-10} / 1.58×10^{-10}	2.11×10^{-10} / 1.60×10^{-10}	3.93×10^{-10} / 2.78×10^{-10}	
6. Spurious Emissions into 50ohms						
Model: Tron 40VDR, S/N: 00001, TUV Ref: TSR3 and Modification State 1						
In band (406.0 – 406.1 MHz)	C/S T.001 mask	P / F	P			
7. 406 MHz VSWR Check						
Model: Tron 40VDR, S/N: 00001, TUV Ref: TSR3 and Modification State 1						
Nominal transmitted frequency (max / min)	C/S T.001	MHz	406.0369376 / 406.0369362	406.0369145 / 406.0369144	406.0369062 / 406.0369045	
Modulation rise time (max/min)	50-250	μ s	145.4 / 142.3	146.4 / 142.3	146.4 / 142.3	
Modulation fall time (max/min)	50-250	μ s	147.6 / 142.6	146.7 / 141.6	146.7 / 142.6	
Modulation phase deviation: positive (max/min)	+ (1.0 to 1.2)	radians	1.2052* / 1.0412	1.2094* / 1.0325	1.1626 / 1.0483	* Phase Deviation outside of spec limits, however the results are inside the limits when expanded by the Test facility Accuracy requirement stated in C/S T.008
Modulation phase deviation: negative (max/min)	- (1.0 to 1.2)	radians	-1.1947 / -1.0287	-1.1853 / -1.0275	-1.1716 / -1.0079	
Modulation symmetry measurement	≤ 0.05		0.0255	0.0248	0.0251	
Digital Message	correct	P / F	P	P	P	



Product Service

Parameters to be Measured	Range of Specification	Units	Test Results			Comments
			Tmin	Tamb	Tmax	
			(-20 °C)	(+21 °C)	(+55 °C)	
8(a). Self-test Mode					Result: Non-compliance	
Model: Tron 40VDR, S/N: 00001, TUV Ref: TSR3 and Modification State 0						
Frame sync	011010000	P / F	P	P	P	Test at ambient with GPS data present. At each temperature, the EUT strobe light emitted one flash, indicating that the Self-Test passed successfully Applicant's data: See Annex A * In accordance with the manufacturer's information, a Self-Test was initiated by holding the activation switch in the 'TEST' position for >15 seconds. The EUT strobe flashed once to indicate completion of a satisfactory Self-Test. Whilst there was no clear indication that RF power has been emitted, output RF power is one of the parameters checked during the Self-Test procedure. The manufacturer operating manual advises that the EUT strobe will flash more than once if a fault is found. The number of flashes depends on the type of fault. The maximum duration of the Self-test can be verified as 17.6 seconds as observed in the Battery current measurements section.
Format flag	1 / 0	bit value	1	1	1	
Single radiated burst	≤440 / 520 (±1%)	ms	519.956	519.907	519.954	
Default position data (if applicable)	correct	P / F	P	P	P	
Description	provided	Y / N	Y			
Design data on protection against repetitive self-test mode transmissions	provided	Y / N	Y			
Single burst verification	one burst	P / F	P	P	P	
Provides for 15 Hex ID	correct	P / F	P	P	P	
121.5 MHz RF power (if applicable)	verify that RF power emitted	P / F	P	P	P	
406 MHz power	verify that RF power emitted	P / F	P	P	P	
Distinct indication of Self-Test	provided		*	*	*	
Distinct indication of RF power being emitted	provided		N	N	N	
Indication of Self-Test result	provided		*	*	*	
Maximum duration of Self-Test mode	≤ maximum duration of Self-Test	sec	*	*	*	
Automatic termination of Self-Test mode upon completion of Self-Test and indication of Self-Test results	verify automatic termination		*	*	*	



Product Service

Parameters to be Measured	Range of Specification	Units	Test Results			Comments	
8 (b). GNSS Self-Test Mode (if applicable)						Result: Pass	
Model: Tron 40VDR, S/N: 00001, TUV Ref: TSR3 and Modification State 0							
Frame sync	011010000		P	P	P	In accordance with the manufacturer's information, a GNSS Self-Test is initiated by moving the activation switch in the 'TEST' position twice within 3 seconds. The EUT emitted an audible tone approximately every 3 seconds until a GPS position was found, whereupon the EUT strobe flashed once and an audible tone indicated that RF had been emitted. If no GPS position was available, the GNSS Self-Test terminated with no further action after 128 seconds, as verified in the battery current measurement results. If a GNSS Self-Test was attempted after the maximum number had been performed, the EUT emitted a series of 10 audible beeps to indicate that no further tests were allowed.	
Format flag	1 / 0	bit value	1	1	1		
Single radiated burst	≤ 520 (+1%)	ms	519.963	519.916	519.912		
Position data (if applicable)	must be within 500m (or 5.25km for User Location Protocol) of the actual position	P / F	P	P	P		
Design data showing how GNSS Self-test is limited in number of transmissions and duration	provided	Y / N	Y				Applicant's data: See Annex A
Single burst verification	one burst	P / F	P	P	P		
121.5 MHz RF power (if applicable)	GNSS self-test checks that RF power is emitted	P / F	P				
406 MHz power	GNSS self-test checks that RF power is emitted	P / F	P				
Maximum duration of GNSS Self-test	-	P / F	P	P	P		Applicant's data: See Annex A
Actual duration of Self-test with encoded location	Less than maximum duration	P / F	P	P	P		
Maximum number of GNSS Self-tests (only beacons with internal navigation devices)	-	Number	60	60	60	Applicant's data: See Annex A	



Product Service

Parameters to be Measured	Range of Specification	Units	Test Results	Comments
10. Operating Lifetime at Minimum Temperature				Result: Pass
Model: Tron 40VDR, S/N: 00001, TUV Ref: TSR3 and Modification State 0 (Battery current measurements included in Modification State 1 for comparison)				
Pre-test battery discharge duration (operating) required		Hours	82.8	
Pre-test battery discharge duration (operating) Duration	>24	Hours	81	
Effective Operating Lifetime duration	>24	Hours	305.56 Hours at Tmin = -20°C	
Transmitted Frequency			303.76 Hours at Tmin = -20°C	
Nominal value	C/S T.001	MHz	Min	Max
Short-term stability	$\leq 2 \times 10^{-9}$	/100ms	406.036938	406.0369416
Medium-term stability – Slope	$(-1 \text{ to } +1) \times 10^{-9}$	/min	3.16×10^{-10}	1.65×10^{-9}
Medium-term stability – Residual frequency variation	$\leq 3 \times 10^{-9}$		-1.60×10^{-10}	2.00×10^{-10}
			7.47×10^{-11}	2.07×10^{-9}
Transmitter power output	35 - 39	dBm	37.37	37.73
Digital message	correct	P/F	P	
Homer transmitter continuous operation during the lifetime test		hours	305	
			Start of Test	End of Test
Homer frequency		MHz	121.5000	121.5000
Homer peak power level		dBm	24.54	24.574
Homer transmitter duty cycle		%	98.1	98.1

Power results figures include the 1.78 dB reduction due to antenna matching network (see manufacturer information, Annex A). Test results exclude first 15 min of data, up to 168 hours 'End of Test' taken as the manufacturer declared value of 168 hours



Product Service

Parameters to be Measured	Range of Specification	Units	Test Results				Comments
14. Satellite Qualitative Tests						Result: Pass	
Model: Tron 40VDR, S/N: 00075, TUV Ref: TSR1 and Modification State 0 (Float-Free Housing)							
Test Configuration	As per C/S T.007		Configuration				
			5	6	7	8	
15 Hex ID Decoded by LUT	correct	P / F	-	-	-	P	
Doppler Location results with error ≤5km	≥80	%	-	-	-	100	
14. Satellite Qualitative Tests						Result: Pass	
Model: Tron 40VDR, S/N: 00075, TUV Ref: TSR1 and Modification State 0 (Stand Alone)							
Test Configuration	As per C/S T.007		Configuration				
			5	6	7	8	
15 Hex ID Decoded by LUT	correct	P / F	-	-	P	P	
Doppler Location results with error ≤5km	≥80	%	-	-	100	100	
14. Satellite Qualitative Tests						Result: Pass	
Model: Tron 40VDR, S/N: 00075, TUV Ref: TSR1 and Modification State 1 (Stand Alone)							
Test Configuration	As per C/S T.007		Configuration				
			5	6	7	8	
15 Hex ID Decoded by LUT	correct	P / F	P	-	-	-	
Doppler Location results with error ≤5km	≥80	%	100	-	-	-	



Product Service

Parameters to be Measured	Range of Specification	Units	Test Results				Comments
15. Antenna Characteristics						Result: Pass	
Model: Tron 40VDR, S/N: 00075, TUV Ref: TSR1 and Modification State 0 (Float-Free Housing)							
Test Configuration	As per C/S T.007		Configuration				Detachable Antennas Only
Polarisation	linear or RHCP		1	2	3	4	
VSWR	≤1.5		-	-	-	Linear	
EIRP _{Loss}		dB	-	-	-	-0.17	
EIRP _{maxEOL}	≤43	dBm	-	-	-	40.6	
EIRP _{minEOL}	≥32	dBm	-	-	-	33.9	
15. Antenna Characteristics						Result: Pass	
Model: Tron 40VDR, S/N: 00075, TUV Ref: TSR1 and Modification State 0 (Stand Alone)							
Test Configuration	As per C/S T.007		Configuration				Detachable Antennas Only
Polarisation	linear or RHCP		1	2	3	4	
VSWR	≤1.5		Linear	-	-	Linear	
EIRP _{Loss}		dB	-0.17	-	-	-0.17	
EIRP _{maxEOL}	≤43	dBm	42.6	-	-	41.6	
EIRP _{minEOL}	≥32	dBm	33.1	-	-	34.1	
16. Beacon Coding Software						Result: Pass	
Model: Tron 40VDR, S/N: 00001, TUV Ref: TSR3 and Modification State 0							
Sample message for each coding option of the applicable coding types	correct	P / F	P				
Sample self-test message for each coding option of the applicable coding types	correct	P / F	P				



Parameters to be Measured	Range of Specification	Units	Test Results			Comments
17. Navigation System						
Model: Tron 40VDR, S/N: 00075 / 00001, TUV Ref: TSR1 / TSR3 and Modification State 0						
Location protocol	C/S T.001		National	Standard	User	
Position data default values	correct	P / F	N/A	P	N/A	
Configuration 5 - Stand Alone						
Position accuracy - A.3.8.2.1	C/S T.001	m	N/A	31.3	N/A	
Position Acquisition Time - A.3.8.2.1	<10/1	min	N/A	0.92	N/A	
Position accuracy - A.3.8.2.2	C/S T.001	m	N/A	49.8	N/A	
Position Acquisition Time - A.3.8.2.2	<10/1	min	N/A	0.92	N/A	
Configuration 7 - Stand Alone						
Position accuracy - A.3.8.2.1	C/S T.001	m	N/A	60.9	N/A	
Position Acquisition Time - A.3.8.2.1	<10/1	min	N/A	0.92	N/A	
Position accuracy - A.3.8.2.2	C/S T.001	m	N/A	49.8	N/A	
Position Acquisition Time - A.3.8.2.2	<10/1	min	N/A	0.92	N/A	
Configuration 8 - Float Free						
Position accuracy - A.3.8.2.1	C/S T.001	m	N/A	60.9	N/A	
Position Acquisition Time - A.3.8.2.1	<10/1	min	N/A	1.76	N/A	
Position accuracy - A.3.8.2.2	C/S T.001	m	N/A	49.8	N/A	
Position Acquisition Time - A.3.8.2.2	<10/1	min	N/A	2.53	N/A	
Configuration 8 - Stand Alone						
Position accuracy - A.3.8.2.1	C/S T.001	m	N/A	60.9	N/A	
Position Acquisition Time - A.3.8.2.1	<10/1	min	N/A	0.92	N/A	
Position accuracy - A.3.8.2.2	C/S T.001	m	N/A	49.8	N/A	
Position Acquisition Time - A.3.8.2.2	<10/1	min	N/A	0.92	N/A	
Encoded position data update interval	> 5	min	N/A	7 min 28 s	N/A	
Position clearance after deactivation	cleared	P / F	N/A	P	N/A	
Position data input update interval (as applicable)	20/1	min	N/A	N/A	N/A	
Position data encoding	correct	P / F	N/A	-	N/A	
Retained last valid position after navigation input lost	240(±5)	min	N/A	240 min 18 s	N/A	
Default position data transmitted after 240(±5) minutes without valid position data	cleared	P / F	N/A	P	N/A	
Information on protection against beacon degradation due to navigation device, interface or signal failure or malfunction	provided	Y / N	Y			Applicant's data, see Annex A for details



Product Service

2.1 DIGITAL MESSAGE

2.1.1 Specification

Cospas-Sarsat T.007, Clause A.2.1 (b)

2.1.2 Equipment Under Test and Modification State

Tron 40VDR S/N: 00001 VDR - Modification State 1

2.1.3 Date of Test

23 June 2014, 24 June 2014 & 25 June 2014

2.1.4 Test Equipment Used

The major items of test equipment used for the above tests are identified in Section 3.1.

2.1.5 Environmental Conditions

Ambient Temperature 22.0 °C – 22.1 °C
Relative Humidity 44.9 % – 55.1%



Product Service

Low Temperature

Full Hex Message: FFFE2F902EF9C0017FDFFF3E4EB783E0F66C

Beacon Id Format..... 30 Hex Id, Long Message, Bits 25-144
 15 Hex (Bits 26- 85) = 205DF38002FFBFF 205DF38002FFBFF Default_Id
 30 Hex (Bits 25-144) = 902EF9C0017FDFFF3E4EB783E0F66C

```

    26  30  34  38  42  46  50  54  58  62  66  70  74  78  82
    |   |   |   |   |   |   |   |   |   |   |   |   |   |
1  0010 0000 0101 1101 1111 0011 1000 0000 0000 0010 1111 1111 1011 1111 1111
    |   |   |   |   |   |   |   |   |   |   |   |   |   |
    1110 0111 1100 1001 1101 0110 1111 0000 0111 1100 0001 1110 1100 1101 100
    |   |   |   |   |   |   |   |   |   |   |   |   |   |
    86  90  94  98  102 106  110  114  118  122  126  130  134  138  142
  
```

Field Name	Bit Pos	Value Decode	Bits
Format Flag	25	1 Long Message	1
Protocol Flag	26	0 Location NEW	0
MID	27- 36	258 NORWAY	0100 0000 10
Protocol Code	37- 40	14 Test Serial (Standard)	1110
Spare	41- 64		1111 1001 1100 0000 0000 0001
Coarse Position	65- 85	DEFAULT	0111 1111 1101 1111 1111 1
BCH Encoded	86-106	Errors=0	1110 0111 1100 1001 1101 0
BCH Generated	86-106		1110 0111 1100 1001 1101 0
Long Message	107-144	Data Present	
Fixed Bits	107-109		110
Fixed Bit	110	1	1
Encode Pos Device	111	1 Internal	1
121.5 Homing	112	1 YES	1
Position Change	113-132	DEFAULT	1000 0011 1110 0000 1111
Resultant Position		--> Not Defined	
BCH Encoded	133-144	Errors=0	0110 0110 1100
BCH Generated	133-144		0110 0110 1100



Product Service

High Temperature

Full Hex Message: FFFE2F902EF9C0017FDFFF3E4EB783E0F66C

Beacon Id Format..... 30 Hex Id, Long Message, Bits 25-144
 15 Hex (Bits 26- 85) = 205DF38002FFBFF 205DF38002FFBFF Default_Id
 30 Hex (Bits 25-144) = 902EF9C0017FDFFF3E4EB783E0F66C

```

    26  30  34  38  42  46  50  54  58  62  66  70  74  78  82
    |   |   |   |   |   |   |   |   |   |   |   |   |   |
1  0010 0000 0101 1101 1111 0011 1000 0000 0000 0010 1111 1111 1011 1111 1111
    1110 0111 1100 1001 1101 0110 1111 0000 0111 1100 0001 1110 1100 1101 100
    |   |   |   |   |   |   |   |   |   |   |   |   |   |
    86  90  94  98  102 106  110  114  118  122  126  130  134  138  142
  
```

Field Name	Bit Pos	Value Decode	Bits
Format Flag	25	1 Long Message	1
Protocol Flag	26	0 Location NEW	0
MID	27- 36	258 NORWAY	0100 0000 10
Protocol Code	37- 40	14 Test Serial (Standard)	1110
Spare	41- 64		1111 1001 1100 0000 0000 0001
Coarse Position	65- 85	DEFAULT	0111 1111 1101 1111 1111 1
BCH Encoded	86-106	Errors=0	1110 0111 1100 1001 1101 0
BCH Generated	86-106		1110 0111 1100 1001 1101 0
Long Message	107-144	Data Present	
Fixed Bits	107-109		110
Fixed Bit	110	1	1
Encode Pos Device	111	1 Internal	1
121.5 Homing	112	1 YES	1
Position Change	113-132	DEFAULT	1000 0011 1110 0000 1111
Resultant Position		--> Not Defined	
BCH Encoded	133-144	Errors=0	0110 0110 1100
BCH Generated	133-144		0110 0110 1100



Product Service

2.2 MODULATION

2.2.1 Specification

Cospas-Sarsat T.007, Clause A.2.1 (d)

2.2.2 Equipment Under Test and Modification State

Tron 40VDR S/N: 00001 VDR - Modification State 1

2.2.3 Date of Test

23 June 2014, 24 June 2014 & 25 June 2014

2.2.4 Test Equipment Used

The major items of test equipment used for the above tests are identified in Section 3.1.

2.2.5 Environmental Conditions

Ambient Temperature 21.0 °C – 22.4 °C
Relative Humidity 47.7 % – 55.1 %



Product Service

2.2.6 Test Results

Ambient Temperature

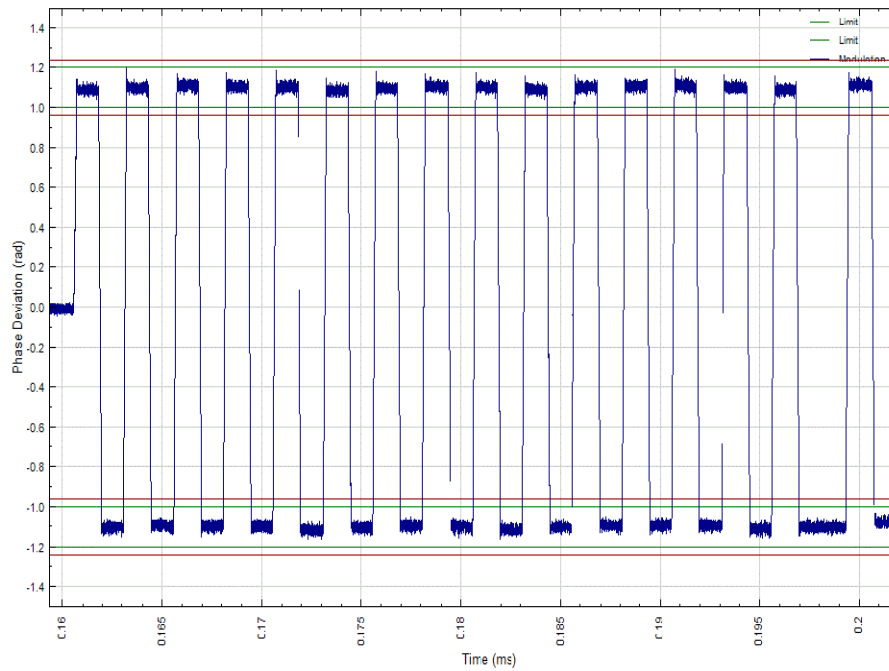

Phase Modulation outside limits stated in T.007 (green line). The measurements are within the Test House Facility Accuracy stated in T.008 (red line).



Product Service

Low Temperature

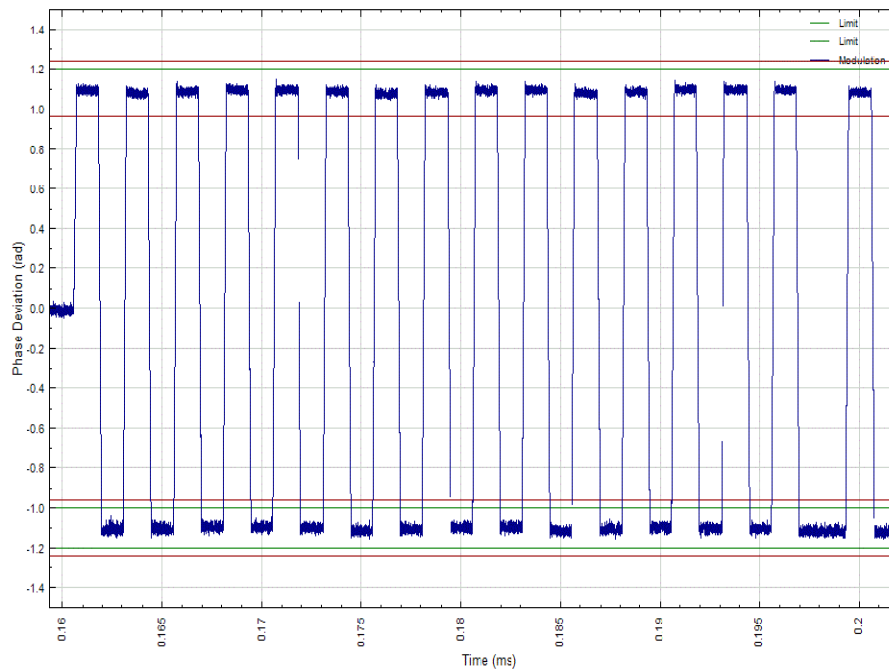



Product Service

High Temperature

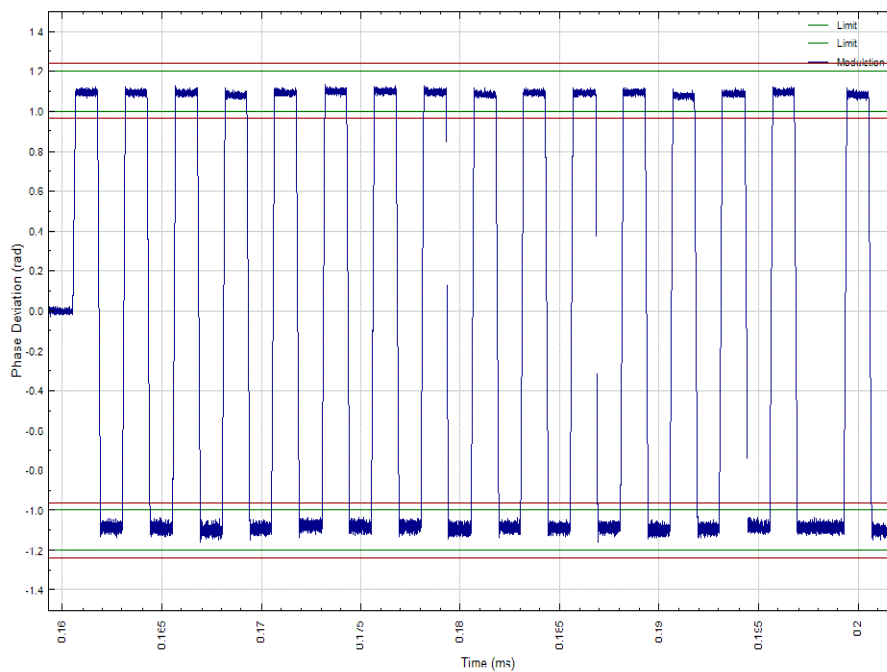



Product Service

2.3 SPURIOUS EMISSION INTO 50 OHMS

2.3.1 Specification

Cospas-Sarsat T.007, Clause A.2.1 (f)

2.3.2 Equipment Under Test and Modification State

Tron 40VDR S/N: 00001 VDR - Modification State 1

2.3.3 Date of Test

26 June 2014

Test Equipment Used

The major items of test equipment used for the above tests are identified in Section 3.1.

2.3.4 Environmental Conditions

Ambient Temperature 22.1 °C
Relative Humidity 47.7 %



Product Service

2.3.5 Test Results

Combined Ambient, Low and High Temperature

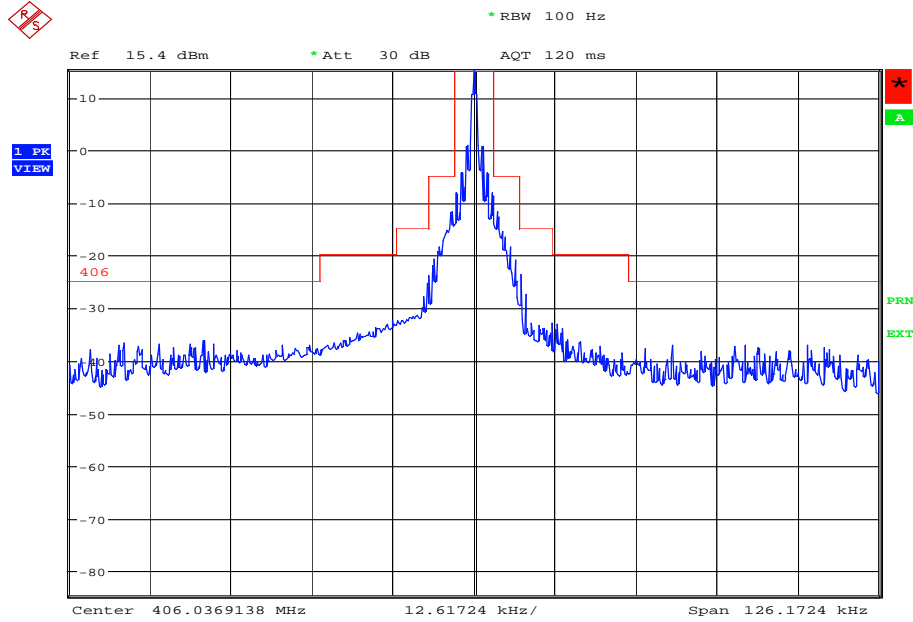

Date: 26.JUN.2014 08:57:37



Product Service

2.4 406 MHZ VSWR CHECK

2.4.1 Specification

Cospas-Sarsat T.007, Clause A.2.1 (g)

2.4.2 Equipment Under Test and Modification State

Tron 40VDR S/N: 00001 VDR - Modification State 1

2.4.3 Date of Test

23 June 2014, 24 June 2014 & 25 June 2014

2.4.4 Test Equipment Used

The major items of test equipment used for the above tests are identified in Section 3.1.

2.4.5 Environmental Conditions

Ambient Temperature 22.0 °C – 22.4 °C
Relative Humidity 47.1 % – 55.1 %



2.4.6 Test Results

Ambient Temperature

Full Hex Message: FFFE2F902EF9C0017FDFFF3E4EB783E0F66C

Beacon Id Format..... 30 Hex Id, Long Message, Bits 25-144
 15 Hex (Bits 26- 85) = 205DF38002FFBFF 205DF38002FFBFF Default_Id
 30 Hex (Bits 25-144) = 902EF9C0017FDFFF3E4EB783E0F66C

```

    26  30  34  38  42  46  50  54  58  62  66  70  74  78  82
    |   |   |   |   |   |   |   |   |   |   |   |   |   |
1  0010 0000 0101 1101 1111 0011 1000 0000 0000 0010 1111 1111 1011 1111 1111
    |   |   |   |   |   |   |   |   |   |   |   |   |   |
    1110 0111 1100 1001 1101 0110 1111 0000 0111 1100 0001 1110 1100 1101 100
    |   |   |   |   |   |   |   |   |   |   |   |   |   |
    86  90  94  98  102 106 110 114 118 122 126 130 134 138 142
  
```

Field Name	Bit Pos	Value	Decode	Bits
Format Flag	25	1	Long Message	1
Protocol Flag	26	0	Location NEW	0
MID	27- 36	258	NORWAY	0100 0000 10
Protocol Code	37- 40	14	Test Serial (Standard)	1110
Spare	41- 64			1111 1001 1100 0000 0000 0001
Coarse Position	65- 85	DEFAULT		0111 1111 1101 1111 1111 1
BCH Encoded	86-106	Errors=0		1110 0111 1100 1001 1101 0
BCH Generated	86-106			1110 0111 1100 1001 1101 0
Long Message	107-144	Data Present		
Fixed Bits	107-109			110
Fixed Bit	110	1		1
Encode Pos Device	111	1	Internal	1
121.5 Homing	112	1	YES	1
Position Change	113-132	DEFAULT		1000 0011 1110 0000 1111
Resultant Position		-->	Not Defined	
BCH Encoded	133-144	Errors=0		0110 0110 1100
BCH Generated	133-144			0110 0110 1100

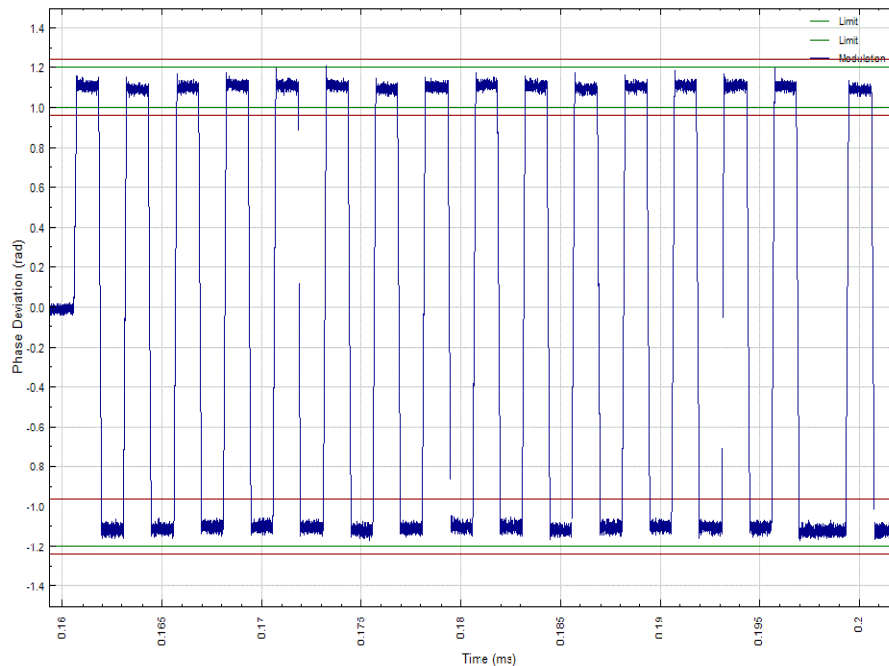

Phase Modulation outside limits stated in T.007 (green line). The measurements are within the Test House Facility Accuracy stated in T.008 (red line).



Product Service

Low Temperature

Full Hex Message: FFFE2F902EF9C0017FDFFF3E4EB783E0F66C

Beacon Id Format..... 30 Hex Id, Long Message, Bits 25-144
 15 Hex (Bits 26- 85) = 205DF38002FFBFF 205DF38002FFBFF Default_Id
 30 Hex (Bits 25-144) = 902EF9C0017FDFFF3E4EB783E0F66C

	26	30	34	38	42	46	50	54	58	62	66	70	74	78	82
1	0010	0000	0101	1101	1111	0011	1000	0000	0000	0010	1111	1111	1011	1111	1111
	1110	0111	1100	1001	1101	0110	1111	0000	0111	1100	0001	1110	1100	1101	100
	86	90	94	98	102	106	110	114	118	122	126	130	134	138	142

Field Name	Bit Pos	Value	Decode	Bits
Format Flag	25	1	Long Message	1
Protocol Flag	26	0	Location NEW	0
MID	27- 36	258	NORWAY	0100 0000 10
Protocol Code	37- 40	14	Test Serial (Standard)	1110
Spare	41- 64			1111 1001 1100 0000 0000 0001
Coarse Position	65- 85		DEFAULT	0111 1111 1101 1111 1111 1
BCH Encoded	86-106		Errors=0	1110 0111 1100 1001 1101 0
BCH Generated	86-106			1110 0111 1100 1001 1101 0
Long Message	107-144		Data Present	
Fixed Bits	107-109			110
Fixed Bit	110	1		1
Encode Pos Device	111	1	Internal	1
121.5 Homing	112	1	YES	1
Position Change	113-132		DEFAULT	1000 0011 1110 0000 1111
Resultant Position		-->	Not Defined	
BCH Encoded	133-144		Errors=0	0110 0110 1100
BCH Generated	133-144			0110 0110 1100

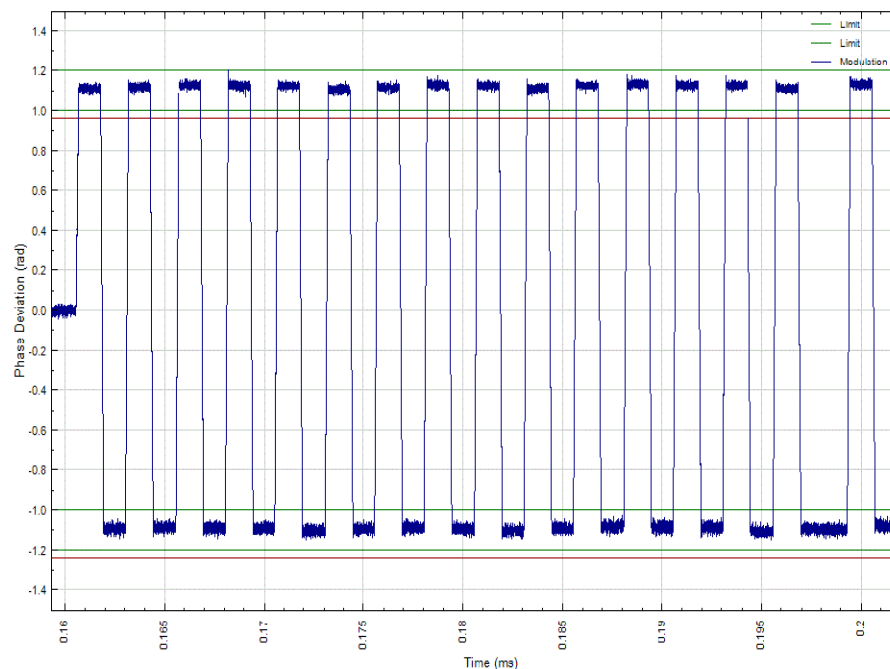

Phase Modulation outside limits stated in T.007 (green line). The measurements are within the Test House Facility Accuracy stated in T.008 (red line).



High Temperature

Full Hex Message: FFFE2F902EF9C0017FDFFF3E4EB783E0F66C

Beacon Id Format..... 30 Hex Id, Long Message, Bits 25-144
 15 Hex (Bits 26- 85) = 205DF38002FFBFF 205DF38002FFBFF Default_Id
 30 Hex (Bits 25-144) = 902EF9C0017FDFFF3E4EB783E0F66C

```

    26  30  34  38  42  46  50  54  58  62  66  70  74  78  82
  1 0010 0000 0101 1101 1111 0011 1000 0000 0000 0010 1111 1111 1011 1111 1111
    1110 0111 1100 1001 1101 0110 1111 0000 0111 1100 0001 1110 1100 1101 100
    86  90  94  98  102 106 110 114 118 122 126 130 134 138 142
  
```

Field Name	Bit Pos	Value	Decode	Bits
Format Flag	25	1	Long Message	1
Protocol Flag	26	0	Location NEW	0
MID	27- 36	258	NORWAY	0100 0000 10
Protocol Code	37- 40	14	Test Serial (Standard)	1110
Spare	41- 64			1111 1001 1100 0000 0000 0001
Coarse Position	65- 85		DEFAULT	0111 1111 1101 1111 1111 1
BCH Encoded	86-106		Errors=0	1110 0111 1100 1001 1101 0
BCH Generated	86-106			1110 0111 1100 1001 1101 0
Long Message	107-144		Data Present	
Fixed Bits	107-109			110
Fixed Bit	110	1		1
Encode Pos Device	111	1	Internal	1
121.5 Homing	112	1	YES	1
Position Change	113-132		DEFAULT	1000 0011 1110 0000 1111
Resultant Position		-->	Not Defined	
BCH Encoded	133-144		Errors=0	0110 0110 1100
BCH Generated	133-144			0110 0110 1100

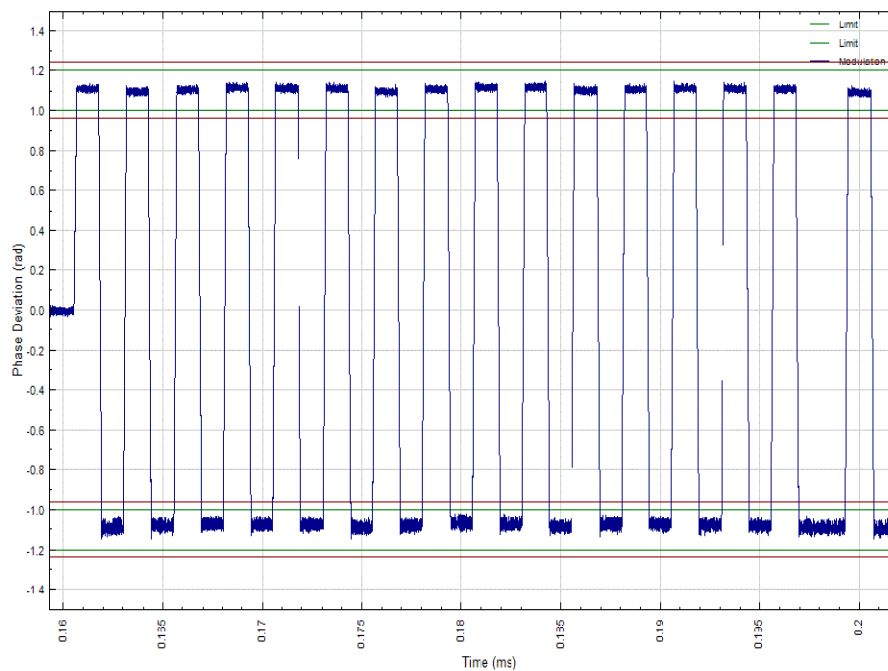



Product Service

2.5 SELF-TEST MODES

2.5.1 Specification

Cospas-Sarsat T.007, Clause A.2.1 (h)

2.5.2 Equipment Under Test and Modification State

Tron 40VDR S/N: 00001 VDR - Modification State 0

2.5.3 Date of Test

27 January 2014, 28 January 2014 & 28 February 2014

2.5.4 Test Equipment Used

The major items of test equipment used for the above tests are identified in Section 3.1.

2.5.5 Environmental Conditions

Ambient Temperature 22.1 °C – 22.9 °C
Relative Humidity 28.4 % – 39.8 %



2.5.6 Test Results

Ambient Temperature (GPS Data applied)

Full Hex Message: FFFED0902EF9C0017FDFFF3E4EB783E0F66C

Beacon Id Format..... 30 Hex Id, Long Message, Bits 25-144
 15 Hex (Bits 26- 85) = 205DF38002FFBFF 205DF38002FFBFF Default_Id
 30 Hex (Bits 25-144) = 902EF9C0017FDFFF3E4EB783E0F66C

```

    26  30  34  38  42  46  50  54  58  62  66  70  74  78  82
    |   |   |   |   |   |   |   |   |   |   |   |   |   |
1  0010 0000 0101 1101 1111 0011 1000 0000 0000 0010 1111 1111 1011 1111 1111
    1110 0111 1100 1001 1101 0110 1111 0000 0111 1100 0001 1110 1100 1101 100
    |   |   |   |   |   |   |   |   |   |   |   |   |   |
    86  90  94  98  102 106 110 114 118 122 126 130 134 138 142
  
```

Field Name	Bit Pos	Value Decode	Bits
Format Flag	25	1 Long Message	1
Protocol Flag	26	0 Location NEW	0
MID	27- 36	258 NORWAY	0100 0000 10
Protocol Code	37- 40	14 Test Serial (Standard)	1110
Spare	41- 64		1111 1001 1100 0000 0000 0001
Coarse Position	65- 85	DEFAULT	0111 1111 1101 1111 1111 1
BCH Encoded	86-106	Errors=0	1110 0111 1100 1001 1101 0
BCH Generated	86-106		1110 0111 1100 1001 1101 0
Long Message	107-144	Data Present	
Fixed Bits	107-109		110
Fixed Bit	110	1	1
Encode Pos Device	111	1 Internal	1
121.5 Homing	112	1 YES	1
Position Change	113-132	DEFAULT	1000 0011 1110 0000 1111
Resultant Position		--> Not Defined	
BCH Encoded	133-144	Errors=0	0110 0110 1100
BCH Generated	133-144		0110 0110 1100



With Valid GPS Input

GNSS Self-test Counter Check

GNSS self-test with valid position	Actual	Declared
Count	60	60
Maximum Duration (s)	125	130
Indication of GNSS ST activation/completion	Upon activation the EUT emits an audible tone every few seconds until either : <ul style="list-style-type: none"> • No GPS fix is found, and the test terminates • A GPS fix is found, the EUT emits two and the strobe flashes to indicate completion of the test 	
Indication of counter limit reached	Audible Tone	

Standard Location Test Protocol Used

	Standard Location Protocol		
	-20 °C	+22 °C	+55 °C
Frame sync verification	011010000	011010000	011010000
Format Flag (1 bit)	1	1	1
Single Radiated burst (ms)	519.963	519.916	519.912
Position data	P	P	P
Single burst verification	P	P	P
Actual duration (sec)	40	30	42
Position Input Latitude	N 51° 22.583'		
Position Input Longitude	W 1° 49.833'		
Position Output Latitude*	N 51°22'36"	N 51°22'36"	N 51°22'36"
Position Output Longitude*	W 1°49'52"	W 1°49'52"	W 1°49'52"
Position Error (m)	50.1	50.1	50.1

Positional accuracy was calculated using the Haversine Formula; the Earth's radius was taken as 6367 km.

Without Valid GPS Input

	Standard Location Protocol		
	-20 °C	+22 °C	+55 °C
Frame sync verification	N/A	N/A	N/A
Format Flag (1 bit)	N/A	N/A	N/A
Single Radiated burst (ms)	N/A	N/A	N/A
Default Position data	N/A	N/A	N/A
Single burst verification	N/A	N/A	N/A
Actual duration (sec)*	125	125	125

* The EUT does not transmit a 406 burst if there is no valid GPS data is present. The measured duration was taken from activating the GNSS Self-test switch to when all activity ceased.



Product Service

2.6 OPERATING LIFETIME AT MINIMUM TEMPERATURE

2.6.1 Specification

Cospas-Sarsat T.007, Clause A.2.3

2.6.2 Equipment Under Test and Modification State

Tron 40VDR S/N: 00001 VDR - Modification State 0
Tron 40VDR S/N: 00001 VDR - Modification State 1 (Battery Current comparison measurements)

2.6.3 Date of Test

7 February 2014 & 21 February 2014
24 June 2014 (Battery Current comparison measurements)

2.6.4 Test Equipment Used

The major items of test equipment used for the above tests are identified in Section 3.1.

2.6.5 Environmental Conditions

Ambient Temperature 20.8 °C – 22.3 °C
Relative Humidity 37.1 % – 42.5 %

2.6.6 Test Results

Note – the results below show the complete test duration of 303 hours separated into two graphs. The initial graph shows results up to 192 hours. The second graphs' timescale starts again at 0, and should be added to the total value.



Product Service

Nominal Frequency

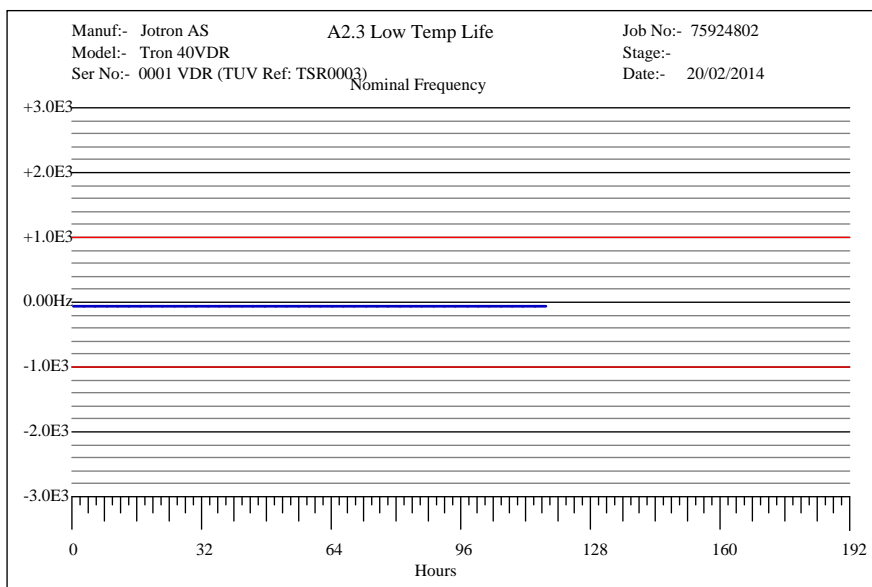
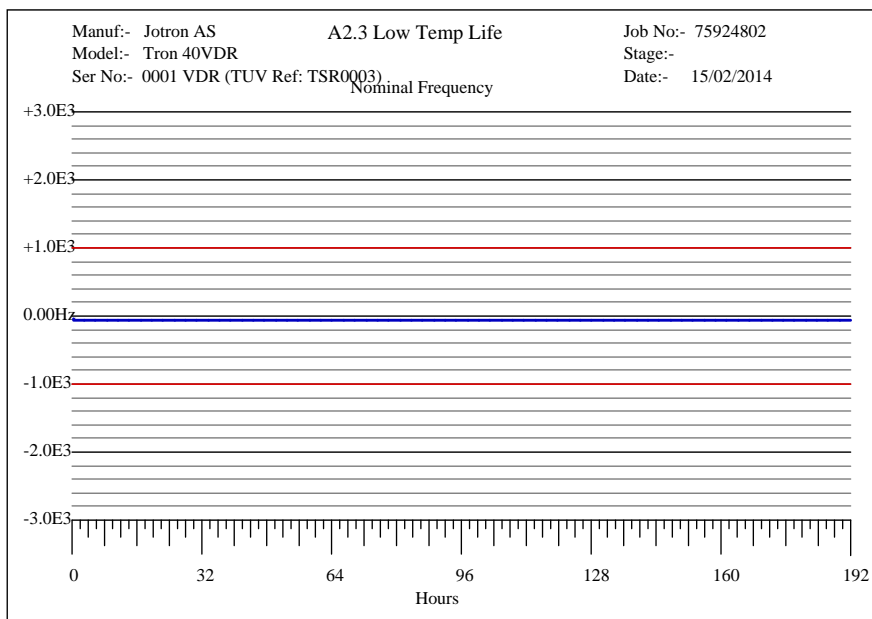



Product Service

Short Term Stability

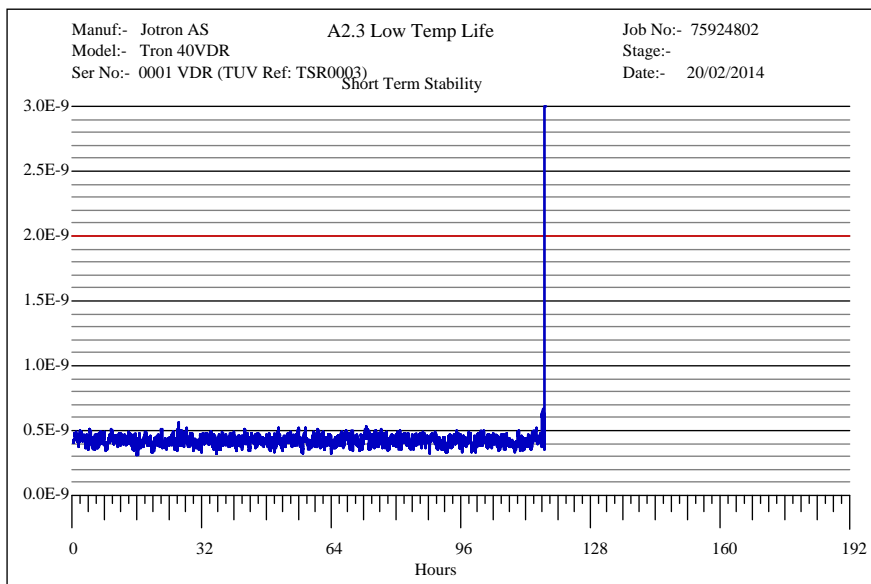
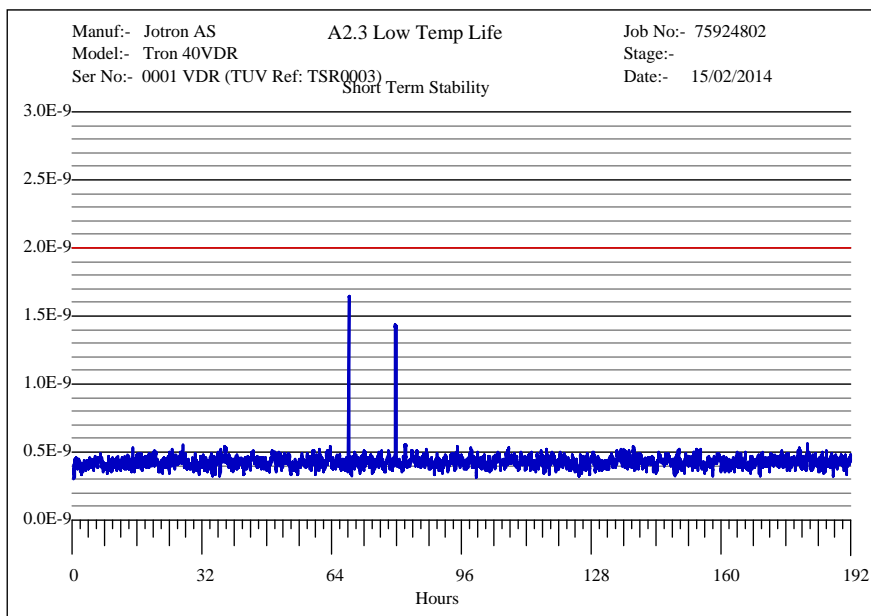



Product Service

Medium Term Stability, Mean Slope

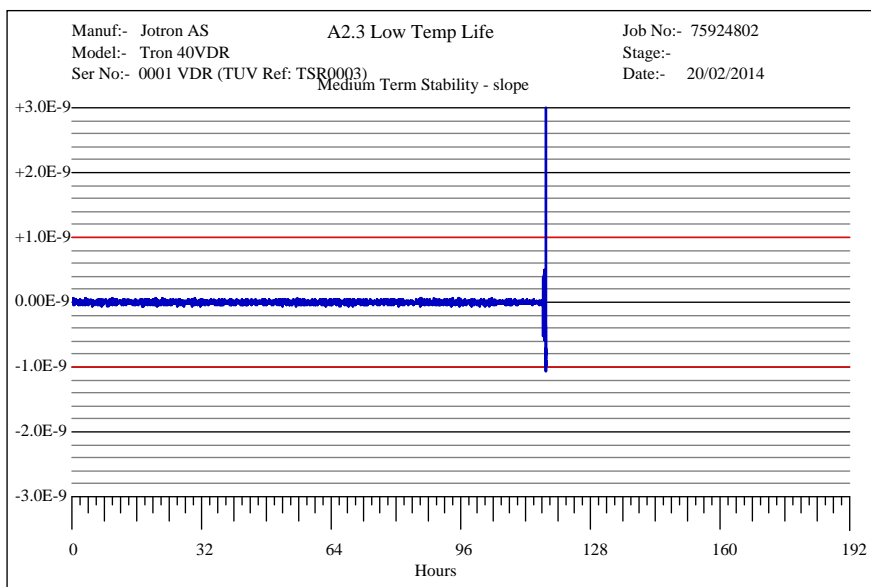
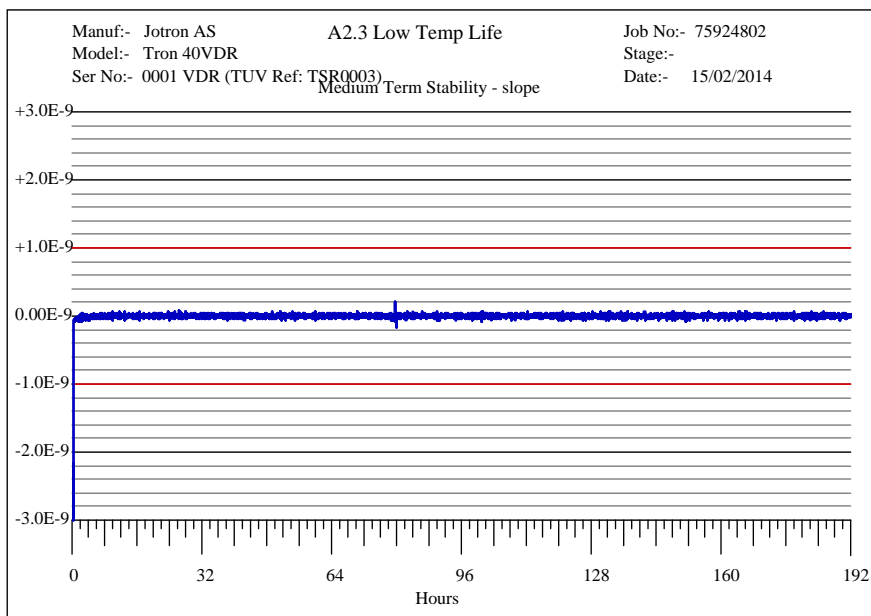



Product Service

Medium Term Stability, Residual Frequency Variation

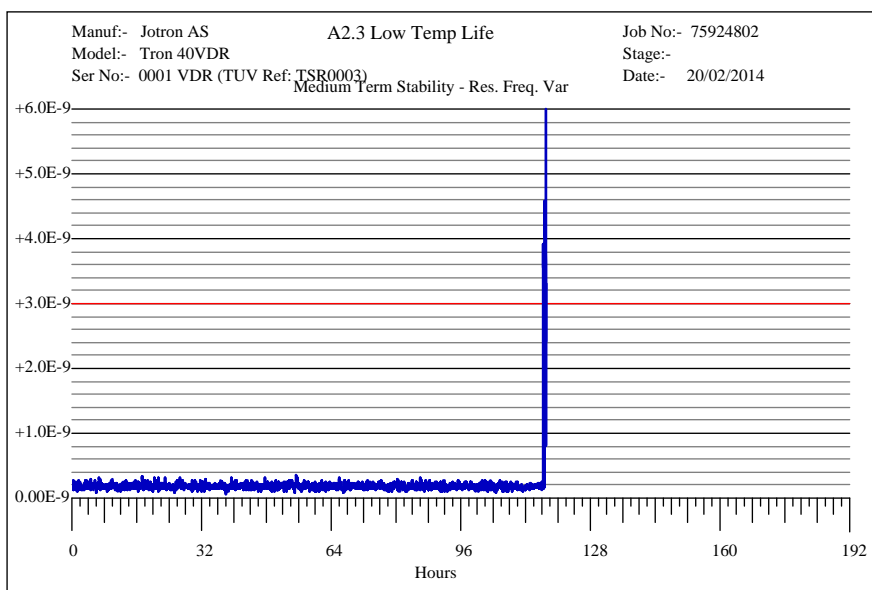
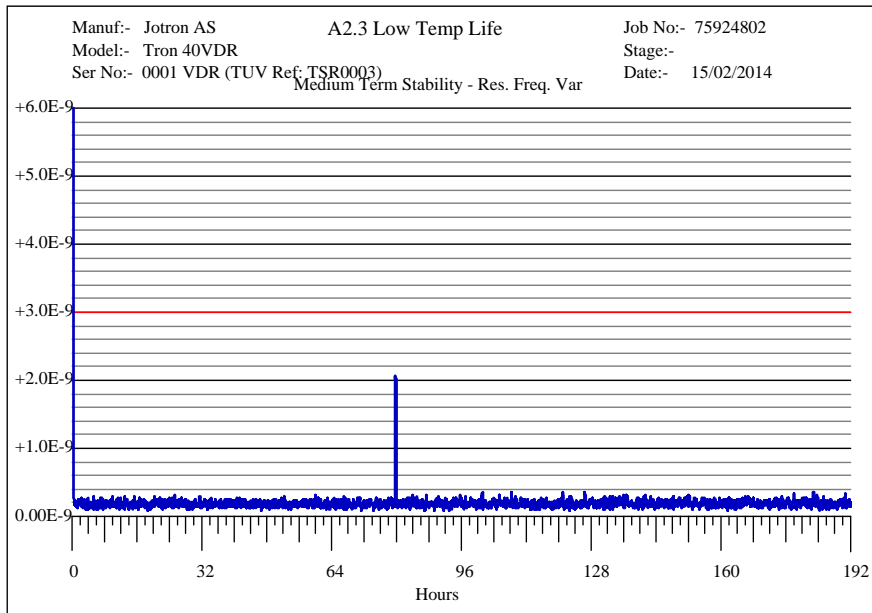



Product Service

Output Power

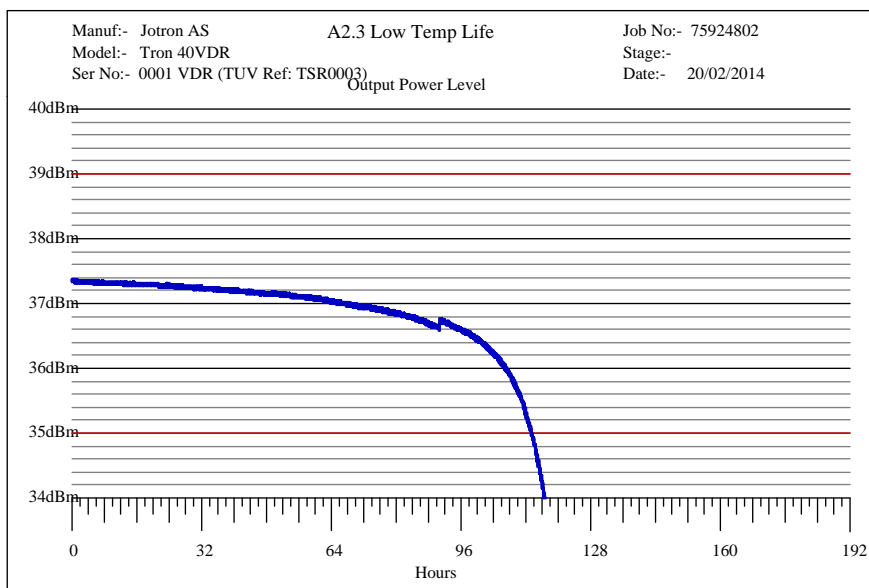
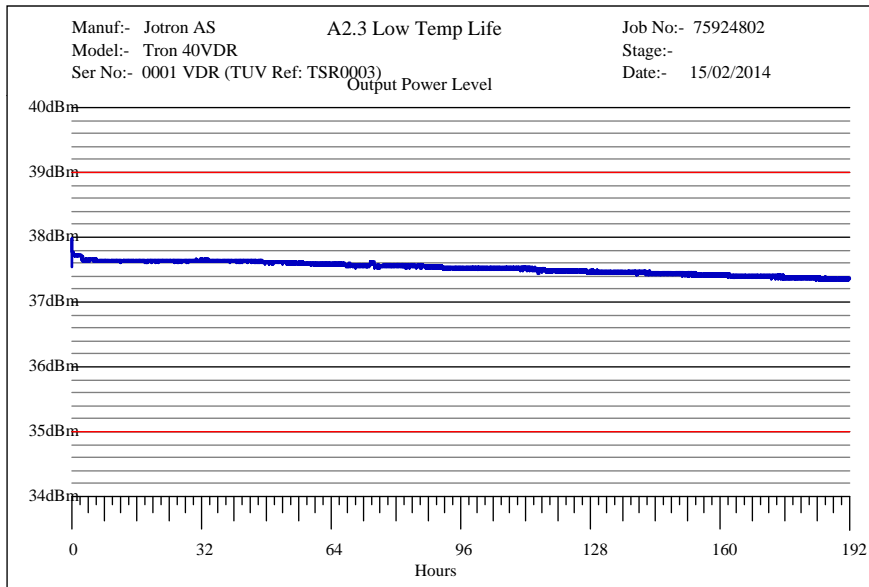

Power plots include the 1.78 dB reduction due to antenna matching network. Test results exclude first 15 min of data, up to 168 hours



Product Service

Digital Message

Full Hex Message: FFFE2F902EF9C0017FDFFF3E4EB783E0F66C

Beacon Id Format..... 30 Hex Id, Long Message, Bits 25-144

15 Hex (Bits 26- 85) = 205DF38002FFBFF 205DF38002FFBFF Default_Id

30 Hex (Bits 25-144) = 902EF9C0017FDFFF3E4EB783E0F66C

```

      26  30  34  38  42  46  50  54  58  62  66  70  74  78  82
      |  |  |  |  |  |  |  |  |  |  |  |  |  |
1 0010 0000 0101 1101 1111 0011 1000 0000 0000 0010 1111 1111 1011 1111 1111
      |  |  |  |  |  |  |  |  |  |  |  |  |  |
      1110 0111 1100 1001 1101 0110 1111 0000 0111 1100 0001 1110 1100 1101 100
      |  |  |  |  |  |  |  |  |  |  |  |  |  |
      86  90  94  98  102 106 110 114 118 122 126 130 134 138 142
  
```

Field Name	Bit Pos	Value Decode	Bits
Format Flag	25	1 Long Message	1
Protocol Flag	26	0 Location NEW	0
MID	27- 36	258 NORWAY	0100 0000 10
Protocol Code	37- 40	14 Test Serial (Standard)	1110
Spare	41- 64		1111 1001 1100 0000 0000 0001
Coarse Position	65- 85	DEFAULT	0111 1111 1101 1111 1111 1
BCH Encoded	86-106	Errors=0	1110 0111 1100 1001 1101 0
BCH Generated	86-106		1110 0111 1100 1001 1101 0
Long Message	107-144	Data Present	
Fixed Bits	107-109		110
Fixed Bit	110	1	1
Encode Pos Device	111	1 Internal	1
121.5 Homing	112	1 YES	1
Position Change	113-132	DEFAULT	1000 0011 1110 0000 1111
Resultant Position		--> Not Defined	
BCH Encoded	133-144	Errors=0	0110 0110 1100
BCH Generated	133-144		0110 0110 1100



Product Service

Test Data (0 min - 30 min)

Burst No.	Nom Freq.	STS	MTS-Slope	MTS-Res	Power	Time (h)
1	-	-	-	-	39.313	0.002444
2	-	-	-	-	39.757	0.016962
3	-	-	-	-	39.670	0.03049
4	-	-	-	-	39.631	0.044509
5	-	-	-	-	39.617	0.058628
6	-	-	-	-	39.604	0.071866
7	-	-	-	-	39.599	0.085178
8	-	-	-	-	39.576	0.099753
9	-	-	-	-	39.573	0.114249
10	-	-	-	-	39.573	0.127595
11	-	-	-	-	39.569	0.141324
12	-	-	-	-	39.559	0.154627
13	-	-	-	-	39.538	0.168759
14	-	-	-	-	39.538	0.18204
15	-	-	-	-	39.554	0.195538
16	-	-	-	-	39.557	0.208963
17	-	-	-	-	39.554	0.223476
18	406036950.6	4.10E-10	-2.16E-09	4.49E-08	39.553	0.237986
19	406036953.6	3.79E-10	-6.28E-09	7.34E-09	39.550	0.251641
20	406036951.9	3.76E-10	-5.83E-09	8.36E-09	39.549	0.264983
21	406036950.2	3.64E-10	-5.27E-09	9.13E-09	39.546	0.278303
22	406036948.7	3.75E-10	-4.61E-09	9.51E-09	39.543	0.292352
23	406036947.2	3.74E-10	-3.90E-09	9.44E-09	39.541	0.30684
24	406036945.9	3.75E-10	-3.19E-09	8.89E-09	39.535	0.320087
25	406036944.7	3.62E-10	-2.48E-09	7.87E-09	39.515	0.333537
26	406036943.7	3.60E-10	-1.82E-09	6.41E-09	39.509	0.347661
27	406036942.9	3.48E-10	-1.26E-09	4.75E-09	39.525	0.360929
28	406036942.3	3.53E-10	-8.05E-10	2.93E-09	39.527	0.374418
29	406036941.9	3.61E-10	-5.03E-10	1.42E-09	39.526	0.388463
30	406036941.6	3.62E-10	-3.50E-10	7.75E-10	39.525	0.402083
31	406036941.5	3.14E-10	-2.67E-10	6.33E-10	39.521	0.416497
32	406036941.4	3.17E-10	-2.10E-10	5.34E-10	39.522	0.430664
33	406036941.3	3.18E-10	-1.54E-10	4.40E-10	39.521	0.445217
34	406036941.3	3.03E-10	-1.10E-10	3.72E-10	39.519	0.459301
35	406036941.2	3.05E-10	-8.65E-11	3.29E-10	39.519	0.472526
36	406036941.2	3.05E-10	-6.29E-11	2.68E-10	39.517	0.486545
37	406036941.1	3.10E-10	-4.68E-11	2.21E-10	39.516	0.501133



Product Service

121 Homing Transmitter - Duty Cycle (Start of Test)

On Time

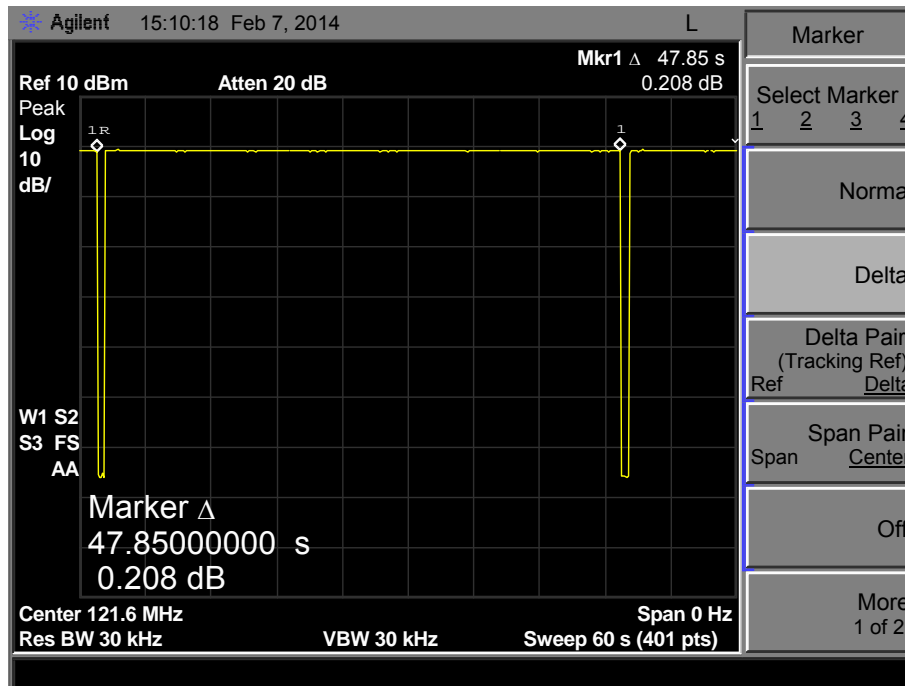

Off Time

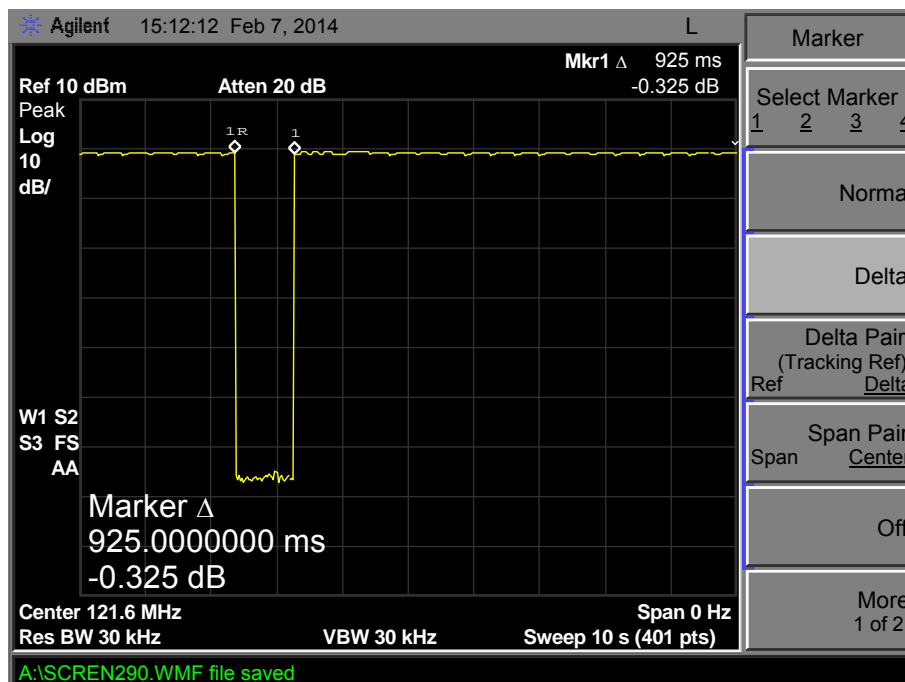

$$\text{Duty Cycle} = 47.85 / (47.85 + 0.925) = 0.981 = \underline{98.1\%}$$



Product Service

121 Homing Transmitter - Duty Cycle (End of Test)

On Time

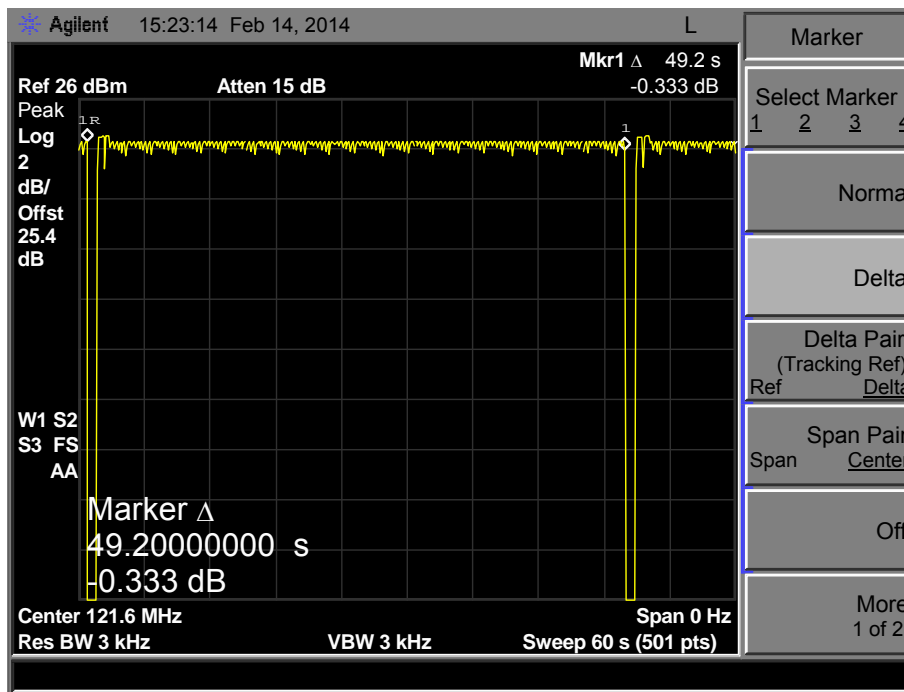

Off Time

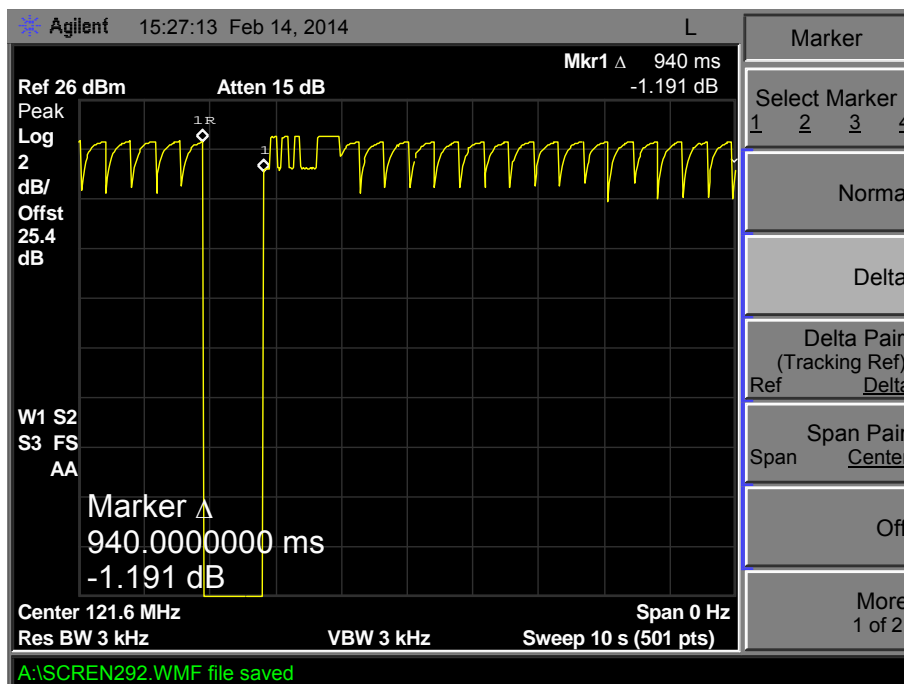

$$\text{Duty Cycle} = 49.2 / (49.2 + 0.94) = 0.981 = \underline{98.1\%}$$



Product Service

121 Homing Transmitter Power (First 24 Hours of Operation)

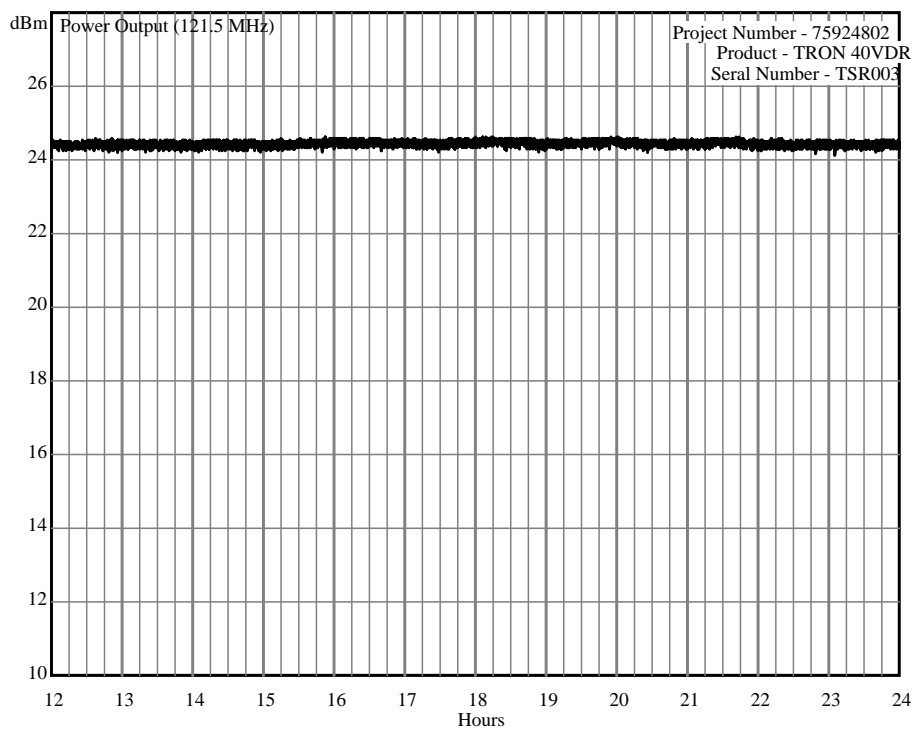
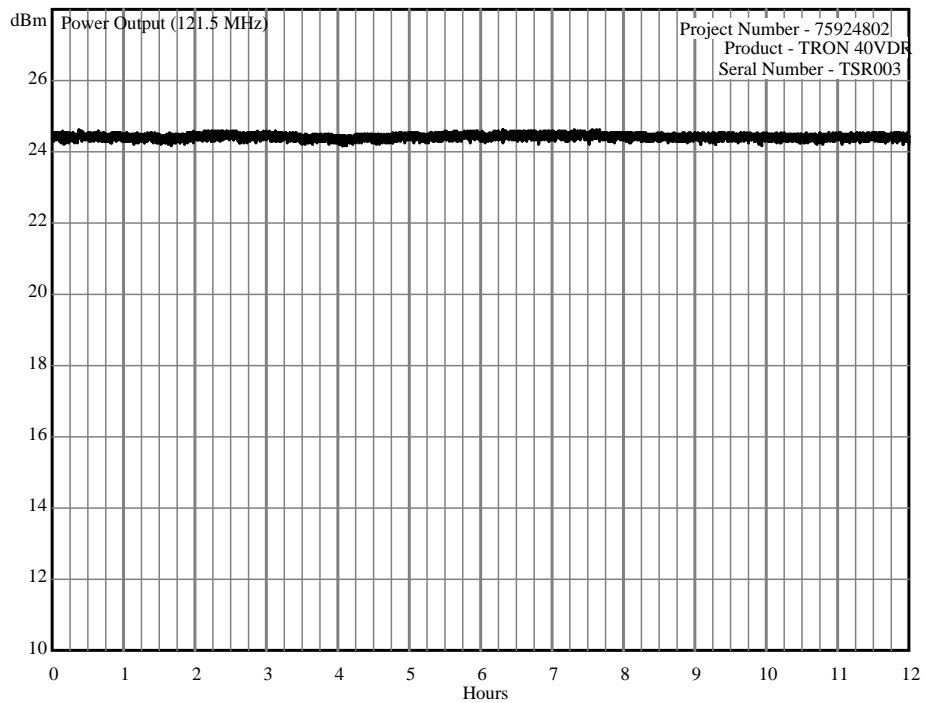



Product Service

121 Homing Transmitter Frequency (First 24 Hours of Operation)

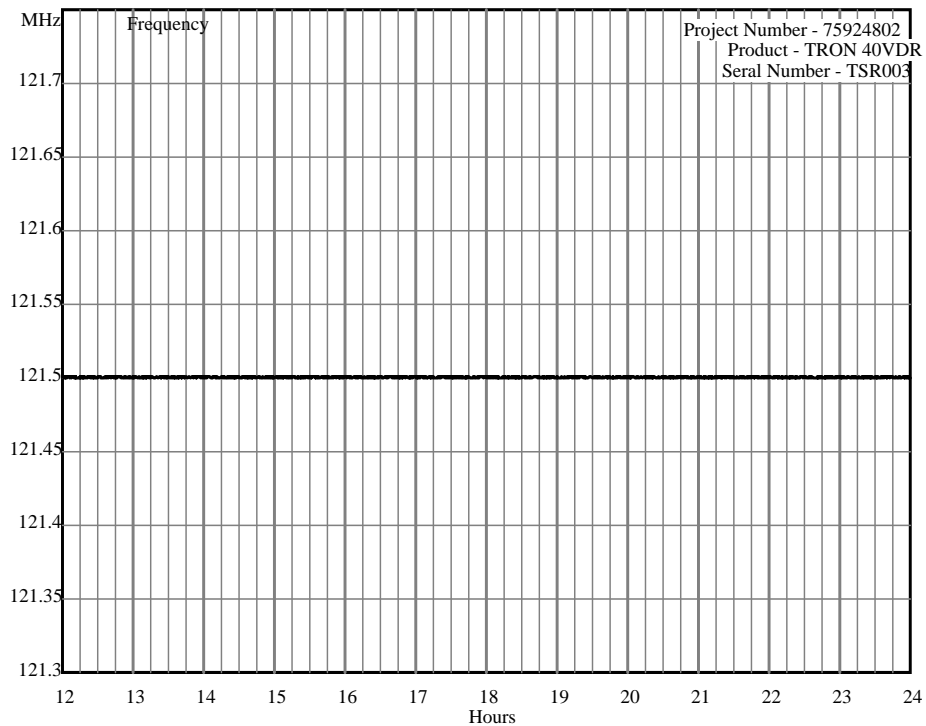
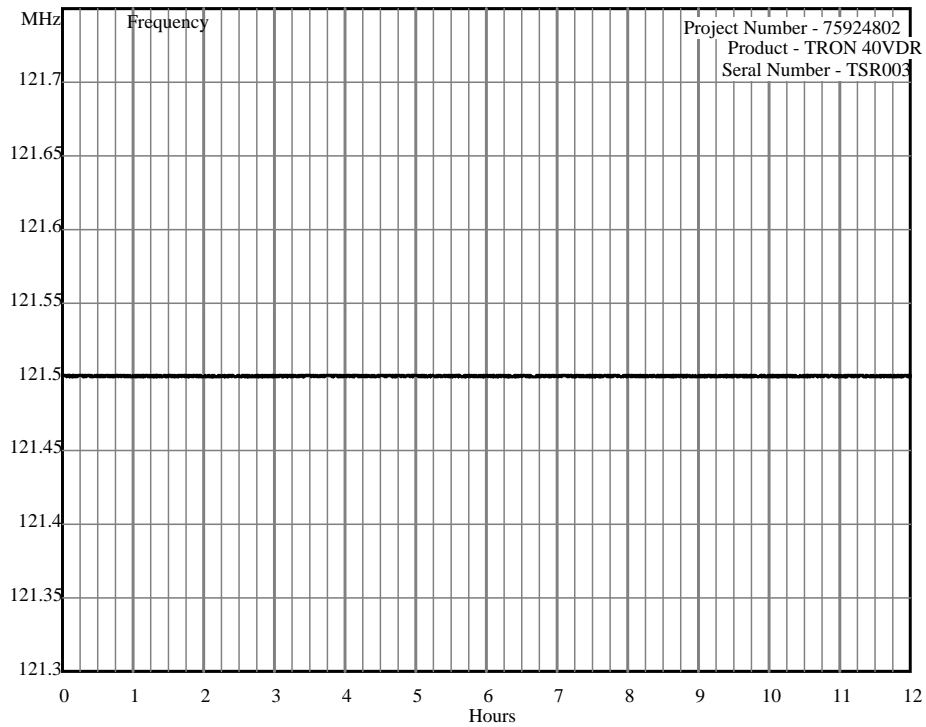



Battery Current Measurement Results

Battery Discharge Current			
The discharge current for the batteries was measured for each of the following beacon states.			
Beacon in the Off or Standby State, "Standby Current"			
Beacon performing a Self-test, "Self-test Current"			
Beacon activated and transmitting, "Operating Current"			
Beacon performing a GNSS Self-test without GPS Data present, "Time-out GNSS ST Current"			
Beacon performing a GNSS Self-test with GPS Data present, "Fast GNSS ST Current"			
The individual tests were conducted for the following durations:			
Standby Current	:	14.9987 minutes	(899920 ms)
Self-test Current	:	17.6 seconds	(17600 ms)
Time-out GNSS ST Current	:	128.0 seconds	(128000 ms)
Fast GNSS ST Current	:	37.3 seconds	(37280 ms)
Operating Current	:	30.0 minutes	(1798800 ms)
Assumptions / Supplied Data			
Battery Replacement Interval	:	6.5 years	5 Years + 1.5 Shelf Life
Battery Capacity	:	18 Ah	
Battery Self Drain	:	3.00 % per year	
Self-test Interval	:	12 tests per year	
GNSS Self-test Interval	:	12 tests per year	
Test Results			
Mode Current	=	Accumulated Charge / Time	
Standby Current	=	1475766434 pC / 899920 ms	= 1639.89 nA
Self-test Current	=	1028764 uC / 17600 ms	= 58.45 mA
Time-out GNSS ST Current	=	3905391.67 uC / 128000 ms	= 30.51 mA
Fast GNSS ST Current	=	1872424.8 uC / 37280 ms	= 50.23 mA
Operating Current	=	78865044.5 uC / 1798800 ms	= 43.84 mA
Battery Preconditioning / Discharge Time Calculations			
Battery Self Drain	=	Capacity - [(100% - Self Drain/Year%) ^{Replacement Interval} x Capacity]	
	=	18 - ((1 - 0.0300) ^{6.5} x 18)	= 3.2331 Ah
Standby Drain	=	Hours per year x Battery Replacement Interval x Standby Current	
	=	365 x 24 x 6.5 x 1639.89 x 10 ⁻⁹	= 0.093375 Ah
Worst Case	=	1.65 x 0.0934 Ah	= 0.154069 Ah
Self-test Drain	=	Self-tests per battery x Self-test Current x Self-test duration (in hours)	
	=	12 x 6.5 x 58.45 x 10 ⁻³ x (17.6 / 3600)	= 0.0223 Ah
Worst Case	=	1.65 x 0.0223 Ah	= 0.0368 Ah
Time-out GNSS ST Drain	=	GNSS STs per battery x Time-out GNSS ST Current x Time-out GNSS ST duration (hours)	
	=	12.00 x 6.5 x 30.51 x 10 ⁻³ x (128 / 3600)	= 0.0846 Ah
Worst Case	=	1.65 x 0.0846 Ah	= 0.1396 Ah
Fast GNSS ST Drain	=	GNSS STs per battery x Fast GNSS ST Current x Fast GNSS ST duration (hours)	
	=	12.00 x 6.5 x 50.23 x 10 ⁻³ x (37.28 / 3600)	= 0.0406 Ah
Worst Case	=	1.65 x 0.0406 Ah	= 0.0669 Ah
Total Drain	=	Self Drain + Standby Drain (Worst Case) + Self-test Drain (Worst Case) + Time-out GNSS ST Current (Worst Case) + Fast GNSS ST Current (Worst Case)	
	=	3.2331 + 0.154069 + 0.0368 + 0.1396 + 0.0669	= 3.6305 Ah
Battery Preconditioning / Discharge Time	=	Worst Case drain / Operational Current	
	=	3.6305 / (43.84 x 10 ⁻³)	
	=	82.81 hours	



Beacon Operating Current

As per C/S T.007 Table F-E.1:

Beacon Operating Modes	Mode: Manually selectable or Automatic	Measurement interval, sec	Average Current, mA	Peak Current, mA
No Ancillaries (VDR Fitted to EUT base) - Standby	A	899.9	0.0016	0.0017
No Ancillaries (VDR Fitted to EUT base) - ON at EUT switch ^{note2}	M	1799	43.84	1939
No Ancillaries (VDR Fitted to EUT base) - ON at EUT (GPS Sleep)	M	348.3	40.54	1894
No Ancillaries (VDR Fitted to EUT base) - ON at Water Contacts	A	1794	44.09	1916
No Ancillaries (VDR Fitted to EUT base) - ON @WCs (GPS Sleep)	A	386.5	40.72	1891
No Ancillaries (VDR Fitted to EUT base) - Self-test	M	17.28	56.62	1897
No Ancillaries (VDR Fitted to EUT base) - GNSS Self-test (No GPS present)	M	128.0	30.51	32.67
No Ancillaries (VDR Fitted to EUT base) - GNSS Self-test (GPS present)	M	37.28	50.23	1896
Automatic release bracket (VDR powered) - Standby	A	899.9	0.0007	0.0008
Automatic release bracket (VDR powered) - ON at EUT switch ^{note1}	M	1796	44.13	2020
Automatic release bracket (VDR powered) - ON at EUT (GPS Sleep)	M	349.0	41.24	1986
Automatic release bracket (VDR powered) - Self-test	M	17.60	58.45	2013
Automatic release bracket (VDR powered) - GNSS Self-test (No GPS present)	M	128.5	29.64	31.54
Automatic release bracket (VDR powered) - GNSS Self-test (GPS present)	M	51.76	42.22	2000

At all times the sampling interval was 80 ms nominal.

Note 1: operating mode during the Operating Lifetime test.

Note 2: operating mode used during pre-test discharge.



Product Service

Battery Current Comparison Measurements (Modification State 1)

Beacon Operating Modes	Mode: Manually selectable or Automatic	Measurement interval, sec	Average Current, mA	Peak Current, mA
No Ancillaries (VDR Fitted to EUT base) - Standby	A	899.9	0.0015	0.0034
No Ancillaries (VDR Fitted to EUT base) - ON at EUT switch ^{note2}	M	1799	46.08	1951
No Ancillaries (VDR Fitted to EUT base) - ON at EUT (GPS Sleep)	M	420.2	42.83	1916
No Ancillaries (VDR Fitted to EUT base) - ON at Water Contacts	A	1799	47.16	1938
No Ancillaries (VDR Fitted to EUT base) - ON @WCs (GPS Sleep)	A	420.1	43.11	1912
No Ancillaries (VDR Fitted to EUT base) - Self-test	M	15.37	66.43	1904
No Ancillaries (VDR Fitted to EUT base) - GNSS Self-test (No GPS present)	M	128.1	32.65	34.92
No Ancillaries (VDR Fitted to EUT base) - GNSS Self-test (GPS present)	M	59.76	43.03	1997
Automatic release bracket (VDR powered) - Standby	A	899.9	0.0007	0.0007
Automatic release bracket (VDR powered) - ON at EUT switch ^{note1}	M	1798	45.43	1872
Automatic release bracket (VDR powered) - ON at EUT (GPS Sleep)	M	420.0	41.65	1842
Automatic release bracket (VDR powered) - Self-test	M	15.35	63.90	1887
Automatic release bracket (VDR powered) - GNSS Self-test (No GPS present)	M	128.0	30.02	32.67
Automatic release bracket (VDR powered) - GNSS Self-test (GPS present)	M	51.84	46.60	1855



Product Service

Battery Current Measurement Graphs

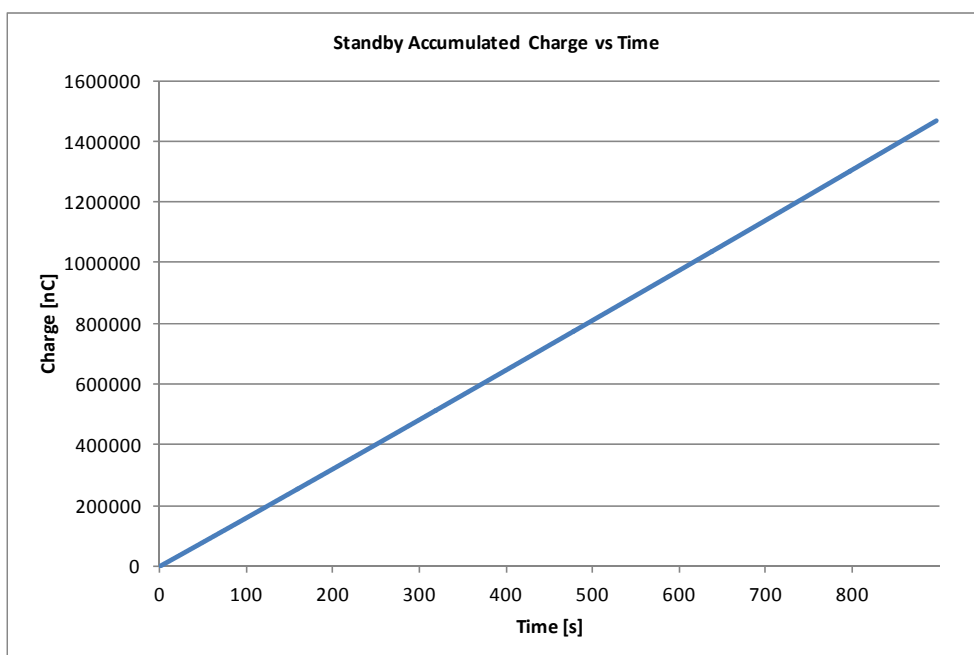
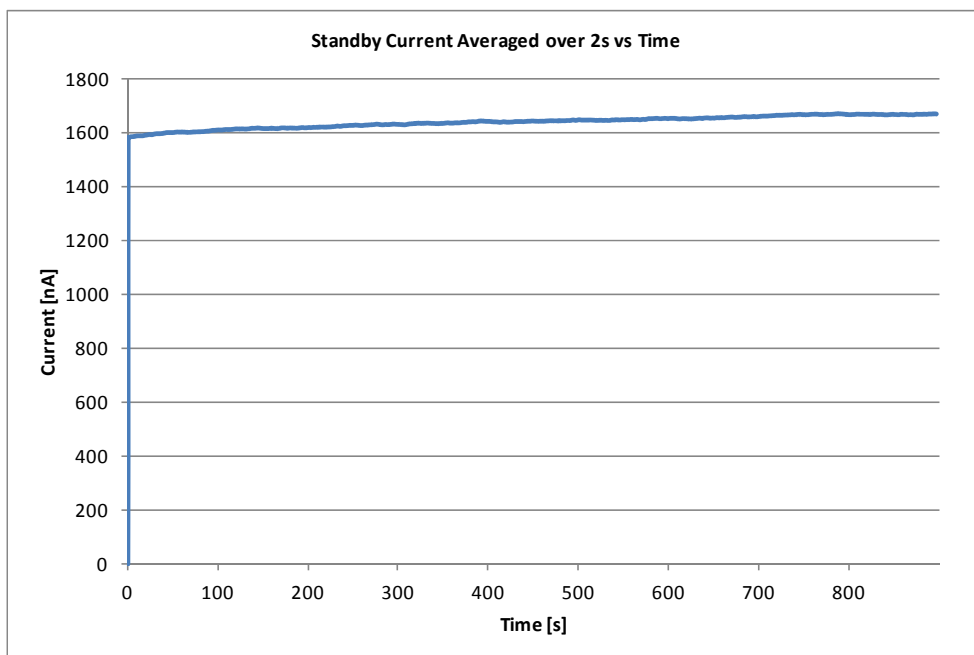



Product Service

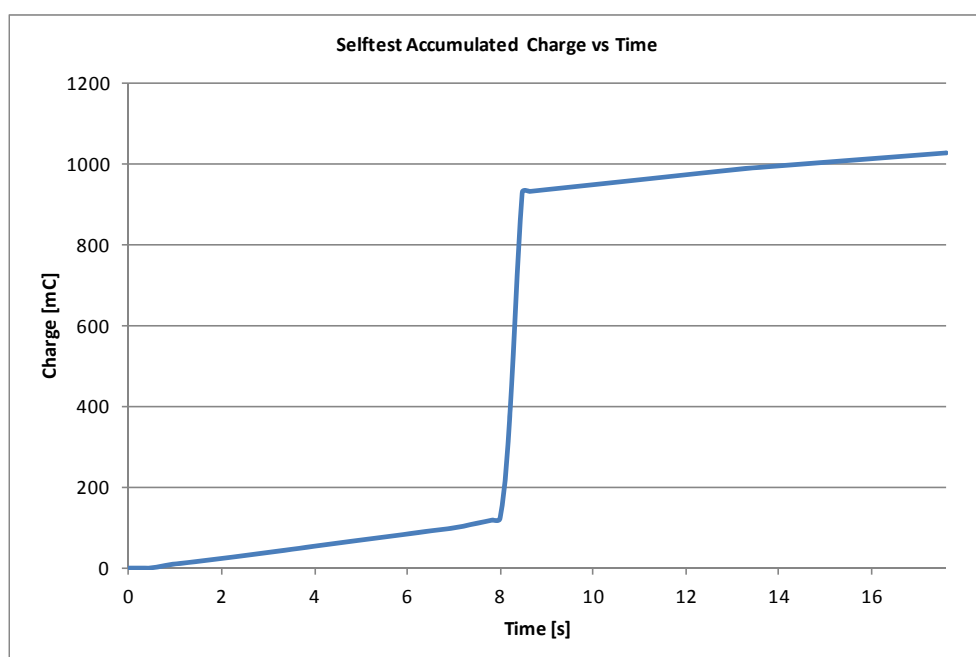
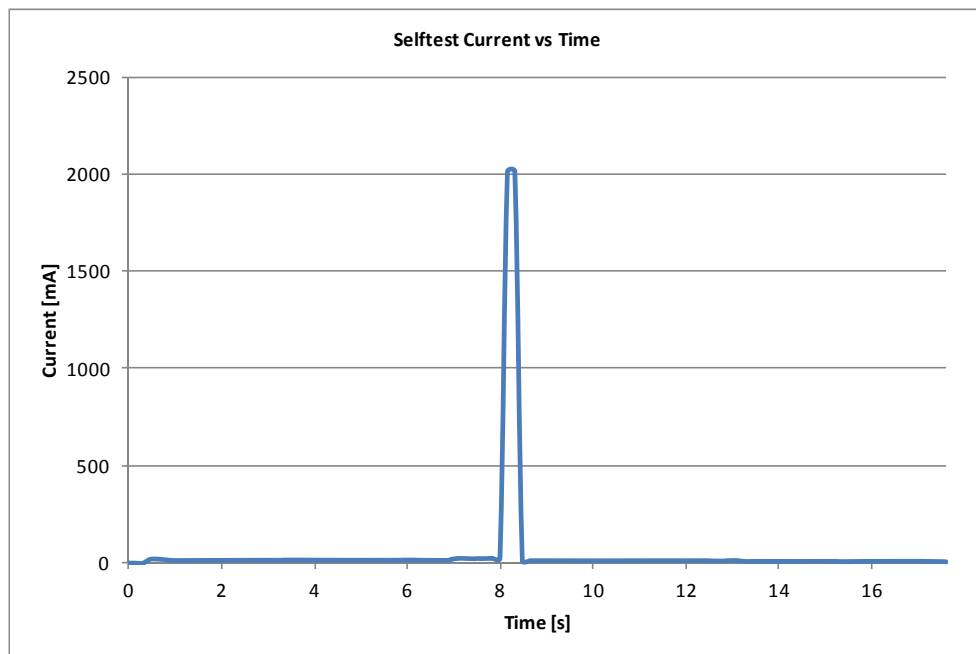



Product Service

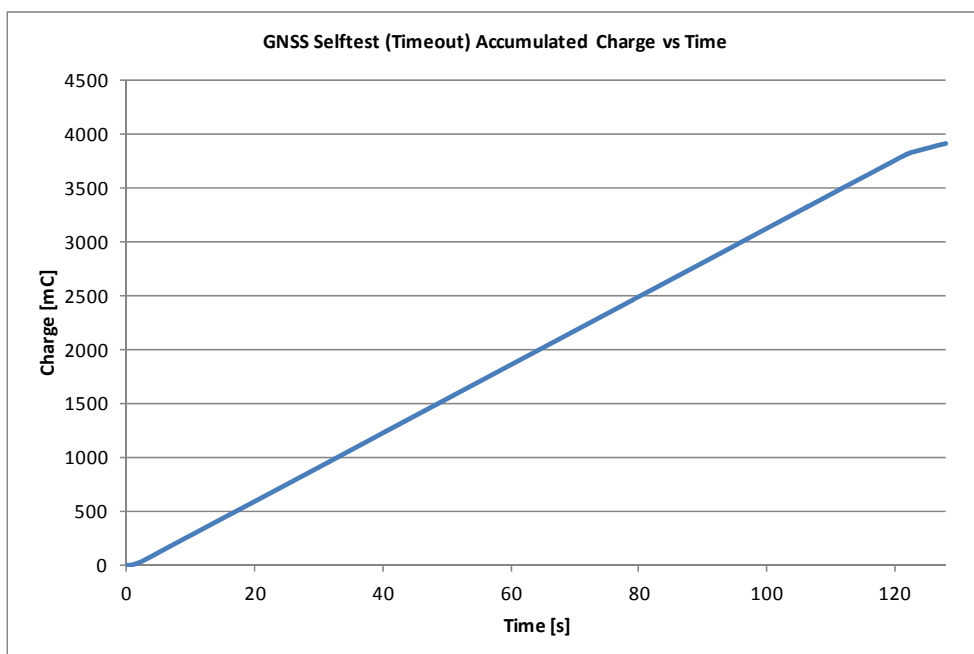
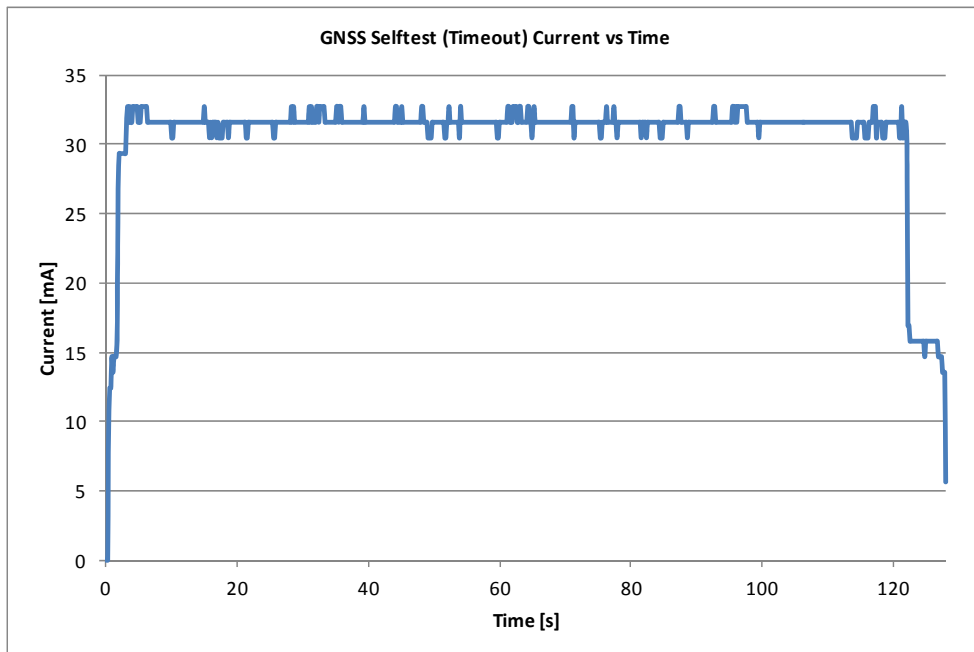



Product Service

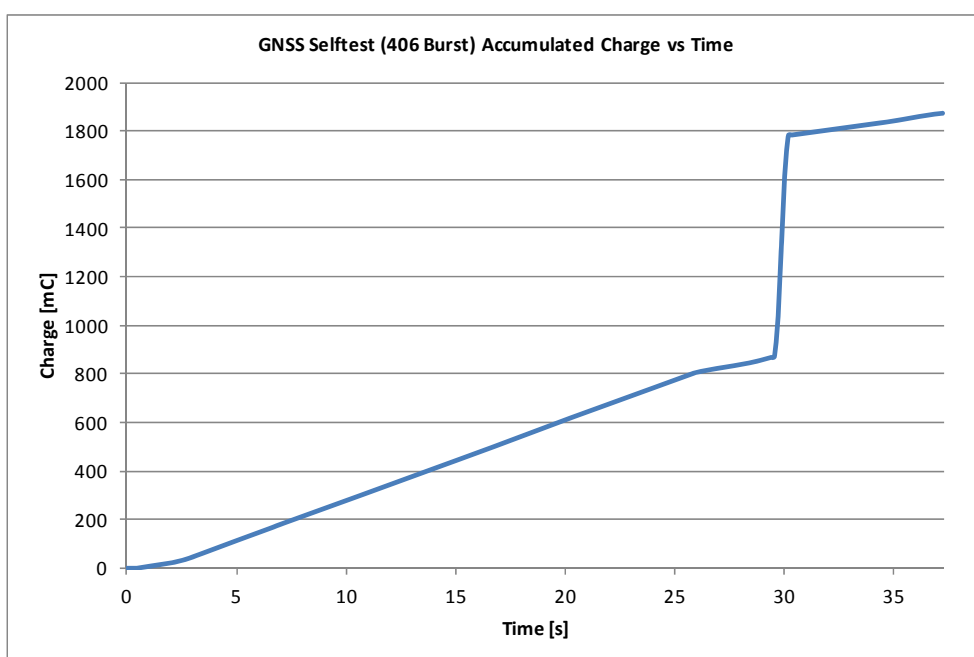
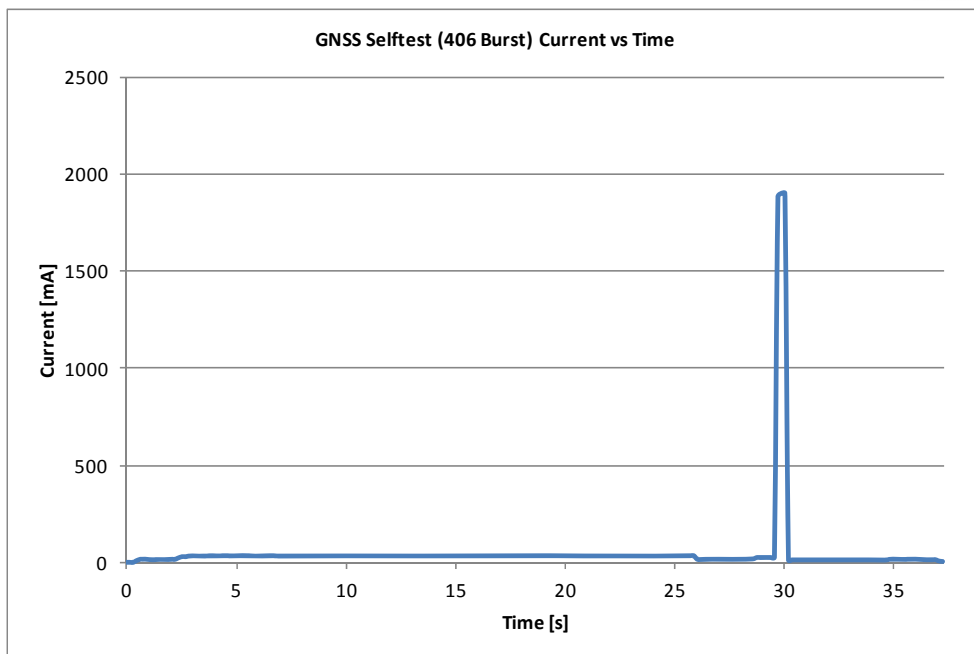



Product Service

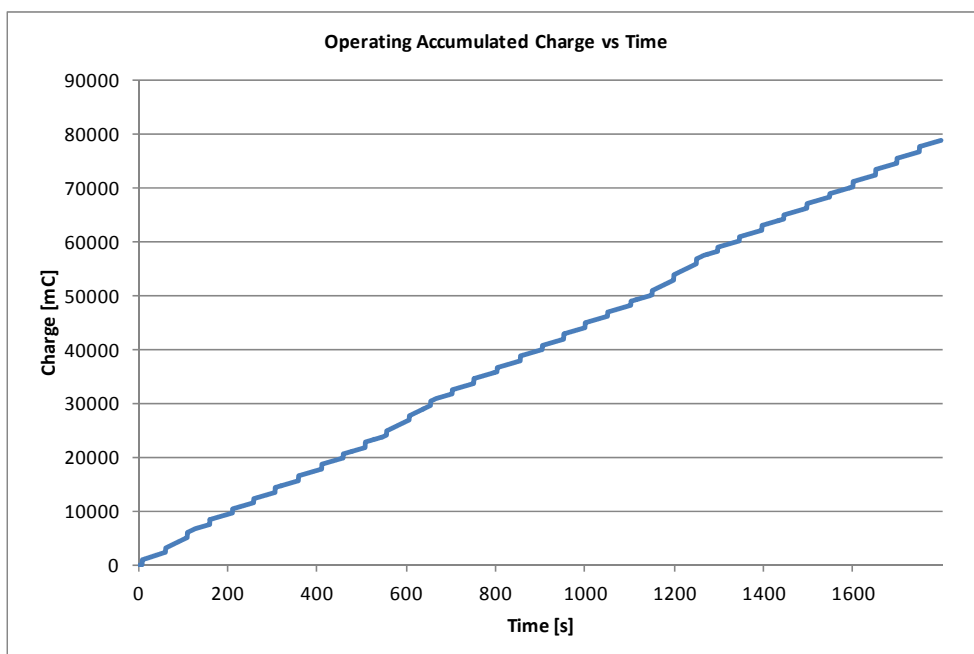
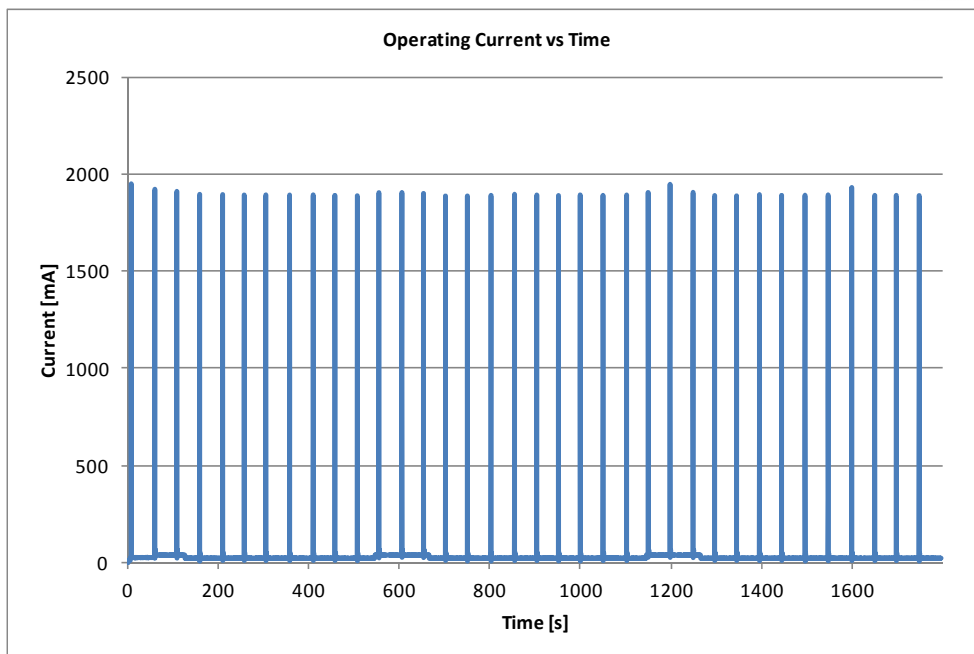



Product Service

2.7 SATELLITE QUALITATIVE TESTS

2.7.1 Specification

Cospas-Sarsat T.007, Clause A.2.5

2.7.2 Equipment Under Test and Modification State

Tron 40VDR S/N: 0075 - Modification State 0 (Configuration 8 in Float-Free Housing and Configurations 7 and 8 with EUT Stand Alone)

Tron 40VDR S/N: 0075 - Modification State 1 (Configuration 5 with EUT Stand Alone)

2.7.3 Date of Test

13 February 2014, 15 February 2014, 16 February 2014, 23 February 2014, 24 February 2014 & 25 February 2014 (Configuration 8 in Float-Free Housing and Configurations 7 & 8 with EUT Stand Alone)

11 July 2014 (Configuration 5 with EUT Stand Alone)

2.7.4 Test Equipment Used

The major items of test equipment used for the above tests are identified in Section 3.1.

2.7.5 Environmental Conditions

Ambient Temperature 6.8 °C – 23.4 °C

Relative Humidity 50.0 % – 88.0 %



Product Service

2.7.6 Test Results

Configuration 8 - EUT in Float-Free Housing (Modification State 0)

Test Start: 22-Feb-14 18:20
 Test End: 23-Feb-14 08:19:54
 15 Hex ID: 205DF 38096 FFBFF

Actual location of the test beacon: 50.818284
 (Daedalus Airfield, Lee-on-the-Solent, East) -1.197328

Satellite ID	Satellite Pass Number	15 Hex ID Provided by LUT	Doppler Latitude	Doppler Longitude	Mean Rx Power (dBm)	TCA	CTA (deg)	Location Error (km)
S13	7304	205DF 38096 FFBFF	50.81906	-1.22644	-136.00	18:47:43	17.750	2.046
S8	69069	205DF 38096 FFBFF	50.83090	-1.21599	-127.72	19:30:40	10.707	1.919
S13	7305	205DF 38096 FFBFF	50.82284	-1.20945	-129.15	20:26:46	4.108	0.990
S8	69070	205DF 38096 FFBFF	50.82555	-1.20384	-127.59	21:11:01	-4.287	0.928
S8	69071	205DF 38096 FFBFF	50.79295	-1.17655	-123.27	22:52:51	-20.371	3.171
S13	7306	205DF 38096 FFBFF	50.81736	-1.19129	-123.91	22:07:12	-11.542	0.436
S11	37989	205DF 38096 FFBFF	50.85409	-1.18250	-118.18	19:32:27	11.506	4.113
S11	37990	205DF 38096 FFBFF	50.82306	-1.19286	-115.28	21:12:09	-3.311	0.616
S11	37991	205DF 38096 FFBFF	50.81867	-1.19512	-117.49	22:53:19	-19.273	0.161
S12	25861	205DF 38096 FFBFF	50.81009	-1.20219	-131.10	00:45:09	-17.324	0.972
S12	25862	205DF 38096 FFBFF	50.81919	-1.21370	-123.29	02:26:47	-1.310	1.154
S10	45020	205DF 38096 FFBFF	50.81007	-1.20854	-127.53	04:05:55	-5.740	1.205
S7	81932	205DF 38096 FFBFF	50.80372	-1.21030	-128.12	05:10:05	-6.061	1.857
S10	45021	205DF 38096 FFBFF	50.81040	-1.19951	-127.78	05:46:27	9.426	0.889
S7	81933	205DF 38096 FFBFF	50.80592	-1.20732	-127.83	06:49:47	9.063	1.543
S13	7312	205DF 38096 FFBFF	50.81704	-1.20584	-133.06	08:38:04	-16.022	0.613
S12	25863	205DF 38096 FFBFF	50.82077	-1.19739	-118.41	04:06:58	13.308	0.276

$$\begin{aligned}
 \text{Ratio of Successful Solutions} &= \frac{\text{number of Doppler solutions within 5 km with } 1^\circ < \text{CTA} < 21^\circ}{\text{number of satellite passes over test duration with } 1^\circ < \text{CTA} < 21^\circ} \\
 &= \frac{17}{17} \\
 &= 100\%
 \end{aligned}$$



Product Service

Configuration 7 - EUT Stand Alone (Modification State 0)

Test Start: 2014-02-13 17:06:00
 Test End: 2014-02-14 08:42:00
 15 Hex ID: 205DF 38096 FFBFF

Actual location of the test beacon: 50.818284
 (Daedalus Airfield, Lee-on-the-Solent, East) -1.197328

Satellite ID	Satellite Pass Number	15 Hex ID Provided by LUT	Doppler Latitude	Doppler Longitude	Mean Rx Power (dBm)	TCA	CTA (deg)	Location Error (km)
S13	7304	205DF 38096 FFBFF	50.81906	-1.22644	-136.00	18:47:43	17.750	2.046
S8	69069	205DF 38096 FFBFF	50.83090	-1.21599	-127.72	19:30:40	10.707	1.919
S13	7305	205DF 38096 FFBFF	50.82284	-1.20945	-129.15	20:26:46	4.108	0.990
S8	69070	205DF 38096 FFBFF	50.82555	-1.20384	-127.59	21:11:01	-4.287	0.928
S8	69071	205DF 38096 FFBFF	50.79295	-1.17655	-123.27	22:52:51	-20.371	3.171
S13	7306	205DF 38096 FFBFF	50.81736	-1.19129	-123.91	22:07:12	-11.542	0.436
S11	37989	205DF 38096 FFBFF	50.85409	-1.18250	-118.18	19:32:27	11.506	4.113
S11	37990	205DF 38096 FFBFF	50.82306	-1.19286	-115.28	21:12:09	-3.311	0.616
S11	37991	205DF 38096 FFBFF	50.81867	-1.19512	-117.49	22:53:19	-19.273	0.161
S12	25861	205DF 38096 FFBFF	50.81009	-1.20219	-131.10	00:45:09	-17.324	0.972
S12	25862	205DF 38096 FFBFF	50.81919	-1.21370	-123.29	02:26:47	-1.310	1.154
S10	45020	205DF 38096 FFBFF	50.81007	-1.20854	-127.53	04:05:55	-5.740	1.205
S7	81932	205DF 38096 FFBFF	50.80372	-1.21030	-128.12	05:10:05	-6.061	1.857
S10	45021	205DF 38096 FFBFF	50.81040	-1.19951	-127.78	05:46:27	9.426	0.889
S7	81933	205DF 38096 FFBFF	50.80592	-1.20732	-127.83	06:49:47	9.063	1.543
S13	7312	205DF 38096 FFBFF	50.81704	-1.20584	-133.06	08:38:04	-16.022	0.613
S12	25863	205DF 38096 FFBFF	50.82077	-1.19739	-118.41	04:06:58	13.308	0.276

$$\begin{aligned}
 \text{Ratio of Successful Solutions} &= \frac{\text{number of Doppler solutions within 5 km with } 1^\circ < \text{CTA} < 21^\circ}{\text{number of satellite passes over test duration with } 1^\circ < \text{CTA} < 21^\circ} \\
 &= \frac{17}{17} \\
 &= 100\%
 \end{aligned}$$



Product Service

Configuration 8 - EUT Stand Alone (Modification State 0)

Test Start: 2014-02-15 18:26:27
 Test End: 2014-02-16 08:51:13
 15 Hex ID: 205DF 38096 FFBFF

Actual location of the test beacon: 50.818284
 (Daedalus Airfield, Lee-on-the-Solent, East) -1.197328

Satellite ID	Satellite Pass Number	15 Hex ID Provided by LUT	Doppler Latitude	Doppler Longitude	Mean Rx Power (dBm)	TCA	CTA (deg)	Location Error (km)
S11	38017	205DF 38096 FFBFF	50.82750	-1.21490	-126.60	18:51:35	16.912	1.603
S8	69097	205DF 38096 FFBFF	50.82861	-1.22347	-126.38	19:06:24	14.019	2.164
S13	7333	205DF 38096 FFBFF	50.81402	-1.20743	-123.66	19:45:35	10.108	0.853
S11	38018	205DF 38096 FFBFF	50.82357	-1.21142	-124.34	20:30:43	3.076	1.151
S13	7334	205DF 38096 FFBFF	50.82034	-1.18420	-126.79	21:25:26	-4.944	0.950
S8	69099	205DF 38096 FFBFF	50.83008	-1.18651	-126.06	22:27:51	-16.413	1.515
S13	7335	205DF 38096 FFBFF	50.82622	-1.20537	-133.28	23:06:46	-20.907	1.047
S11	38019	205DF 38096 FFBFF	50.81683	-1.17050	-119.10	22:11:16	-12.661	1.890
S12	25889	205DF 38096 FFBFF	50.80421	-1.19496	-124.98	00:22:52	-20.820	1.573
S12	25890	205DF 38096 FFBFF	50.81593	-1.20395	-126.39	02:04:51	-4.737	0.533
S10	45048	205DF 38096 FFBFF	50.81159	-1.20970	-126.73	03:43:16	-9.358	1.144
S7	81960	205DF 38096 FFBFF	50.80596	-1.20695	-128.18	04:20:39	-13.904	1.527
S10	45049	205DF 38096 FFBFF	50.80893	-1.19347	-126.71	05:24:08	6.179	1.074
S7	81961	205DF 38096 FFBFF	50.80670	-1.17850	-124.95	06:01:01	1.857	1.845
S10	45050	205DF 38096 FFBFF	50.82409	-1.19069	-118.66	07:03:34	19.329	0.796
S7	81962	205DF 38096 FFBFF	50.81016	-1.20582	-127.42	07:40:01	15.858	1.082
S11	38025	205DF 38096 FFBFF	50.81088	-1.20110	-125.65	08:42:09	-14.879	0.864
S12	25891	205DF 38096 FFBFF	50.82051	-1.19767	-113.40	03:45:21	10.338	0.249

$$\begin{aligned}
 \text{Ratio of Successful Solutions} &= \frac{\text{number of Doppler solutions within 5 km with } 1^\circ < \text{CTA} < 21^\circ}{\text{number of satellite passes over test duration with } 1^\circ < \text{CTA} < 21^\circ} \\
 &= \frac{18}{18} \\
 &= 100\%
 \end{aligned}$$



Product Service

Configuration 5 - EUT Stand Alone (Modification State 1)

Test Start: 2014-07-10 17:28:42
 Test End: 2014-07-11 07:40:18
 15 Hex ID: 205DF 38096 FFBFF

Actual location of the test beacon: Latitude (°): 50.818263
 (MCA Daedalus) Longitude (°): -1.197454

Satellite ID	Satellite Pass Number	15 Hex ID Provided by LUT	Doppler Latitude	Doppler Longitude	Mean Rx Power (dBm)	TCA	CTA (deg)	Location Error (km)
S7	84020	205DF 38096 FFBFF	50.83147	-1.18410	-127.13	18:25:46	-18.315	1.741
S11	40077	205DF 38096 FFBFF	50.82711	-1.21928	-127.90	18:52:28	16.858	1.820
S13	9393	205DF 38096 FFBFF	50.82649	-1.21485	-129.20	19:45:10	10.099	1.526
S11	40078	205DF 38096 FFBFF	50.82287	-1.21158	-126.22	20:31:36	3.020	1.116
S13	9394	205DF 38096 FFBFF	50.82568	-1.18957	-127.39	21:25:01	-4.953	0.993
S11	40079	205DF 38096 FFBFF	50.82553	-1.18834	-125.48	22:12:09	-12.708	1.030
S13	9395	205DF 38096 FFBFF	50.82129	-1.19396	-136.30	23:06:21	-20.926	0.416
S12	27935	205DF 38096 FFBFF	50.80412	-1.20533	-129.03	00:41:08	-18.961	1.666
S12	27936	205DF 38096 FFBFF	50.81870	-1.22102	-126.43	02:22:56	-2.908	1.655
S10	47094	205DF 38096 FFBFF	50.80294	-1.19987	-129.75	03:15:57	-16.795	1.711
S12	27937	205DF 38096 FFBFF	50.81421	-1.19772	-125.68	04:03:15	11.942	0.451
S7	84026	205DF 38096 FFBFF	50.80538	-1.20210	-127.14	04:54:45	-9.607	1.468
S7	84027	205DF 38096 FFBFF	50.81037	-1.19565	-128.26	06:34:45	5.850	0.886
S10	47096	205DF 38096 FFBFF	50.82089	-1.19095	-119.58	06:37:34	13.685	0.542

$$\begin{aligned}
 \text{Ratio of Successful Solutions} &= \frac{\text{number of Doppler solutions within 5 km with } 1^\circ < \text{CTA} < 21^\circ}{\text{number of satellite passes over test duration with } 1^\circ < \text{CTA} < 21^\circ} \\
 &= \frac{14}{14} \\
 &= 100\%
 \end{aligned}$$



Product Service

BEACON ANTENNA TEST

2.7.1 Specification

Cospas-Sarsat T.007, Clause A.2.6

2.7.2 Equipment Under Test and Modification State

Tron 40VDR S/N: 0075 - Modification State 0

2.7.3 Date of Test

5 February 2014

2.7.4 Test Equipment Used

The major items of test equipment used for the above tests are identified in Section 3.1.

2.7.5 Environmental Conditions

Ambient Temperature 18.0 °C
Relative Humidity 44.0 %

2.7.6 Test Results

Configuration 4 - EUT in Float-Free Housing

Azimuth Angle (Degrees)	Elevation Angle (degrees)									
	10		20		30		40		50	
	EIRP dBm	Ant dBi	EIRP dBm	Ant dBi	EIRP dBm	Ant dBi	EIRP dBm	Ant dBi	EIRP dBm	Ant dBi
0	38.8	1.59	39.8	2.60	39.7	2.54	34.9	-2.34	26.5	-10.69
90	38.6	1.42	39.9	2.70	40.2	2.99	36.2	-0.98	27.0	-10.25
180	39.2	2.02	40.0	2.84	38.9	1.74	33.9	-3.34	26.9	-10.31
270	38.4	1.17	40.4	3.24	39.1	1.94	34.9	-2.28	26.7	-10.54

$$EIRP_{LOSS} = Pt_{ambient} - Pt_{EOL} = 37.2 - 37.37 = -0.17 \text{ dB}$$

$$EIRP_{maxEOL} = \text{Max}[EIRP_{max}, (EIRP_{max} - EIRP_{LOSS})] = \text{Max}[40.4, 40.6] = 40.6 \text{ dBm}$$

$$EIRP_{minEOL} = \text{Min}[EIRP_{min}, (EIRP_{min} - EIRP_{LOSS})] = \text{Min}[33.9, 34.0] = 33.9 \text{ dBm}$$



Product Service

Configuration 1 - EUT Stand Alone

Azimuth Angle (Degrees)	Elevation Angle (degrees)									
	10		20		30		40		50	
	EIRP dBm	Ant dBi	EIRP dBm	Ant dBi	EIRP dBm	Ant dBi	EIRP dBm	Ant dBi	EIRP dBm	Ant dBi
0	39.1	1.86	40.8	3.62	42.3	5.08	38.0	0.80	33.8	-3.37
30	38.1	0.92	40.4	3.19	41.8	4.62	37.6	0.44	33.9	-3.31
60	37.8	0.63	40.2	3.01	41.7	4.54	37.6	0.41	33.5	-3.68
90	37.7	0.48	40.1	2.92	41.7	4.50	37.5	0.30	33.2	-4.04
120	37.7	0.49	39.9	2.74	41.4	4.25	37.5	0.29	33.1	-4.14
150	37.8	0.63	40.0	2.80	41.4	4.24	37.5	0.30	33.5	-3.68
180	37.9	0.67	40.3	3.08	41.7	4.51	37.5	0.28	33.3	-3.87
210	38.4	1.16	40.7	3.47	41.9	4.68	37.7	0.47	33.5	-3.75
240	38.6	1.39	40.9	3.70	42.1	4.93	37.9	0.67	33.9	-3.26
270	38.6	1.42	41.2	3.96	42.4	5.18	38.3	1.05	34.1	-3.12
300	38.7	1.52	41.1	3.89	42.3	5.07	38.3	1.06	34.2	-3.01
330	38.7	1.46	41.1	3.86	42.2	5.00	38.0	0.83	34.3	-2.93

Azimuth Angle (Degrees)	Elevation Angle (degrees)									
	10		20		30		40		50	
	Vv	Vh	Vv	Vh	Vv	Vh	Vv	Vh	Vv	Vh
0	110.85	82.41	112.21	74.16	112.96	79.12	107.53	90.18	101.73	88.35
30	109.90	85.38	111.78	64.61	112.50	81.91	107.16	90.71	101.72	89.65
60	109.62	82.39	111.60	75.99	112.42	80.03	107.10	91.54	101.42	87.92
90	109.46	85.24	111.51	75.88	112.38	80.26	107.03	89.78	101.10	86.52
120	109.48	82.45	111.33	68.85	112.12	83.14	107.01	90.37	101.04	84.95
150	109.62	83.28	111.38	83.60	112.12	78.29	107.07	86.67	101.51	84.98
180	109.66	78.38	111.66	81.81	112.39	78.86	107.03	88.66	101.39	80.04
210	110.15	82.91	112.05	83.40	112.56	82.33	107.23	88.23	101.50	81.37
240	110.38	82.95	112.28	86.51	112.81	82.34	107.45	86.90	101.99	82.04
270	110.41	81.27	112.55	73.96	113.06	82.69	107.81	89.07	102.12	82.83
300	110.50	84.87	112.47	82.60	112.95	68.51	107.83	88.11	102.14	87.15
330	110.45	80.22	112.45	67.42	112.88	77.44	107.59	88.53	102.26	85.85
Min (Vv-Vh)	24.22		25.77		28.98		15.56		12.07	

$$EIRP_{LOSS} = Pt_{ambient} - Pt_{EOL} = 37.2 - 37.37 = -0.17 \text{ dB}$$

$$EIRP_{maxEOL} = \text{Max}[EIRP_{max}, (EIRP_{max} - EIRP_{LOSS})] = \text{Max}[42.4, 42.6] = 42.6 \text{ dBm}$$

$$EIRP_{minEOL} = \text{Min}[EIRP_{min}, (EIRP_{min} - EIRP_{LOSS})] = \text{Min}[33.1, 33.2] = 33.1 \text{ dBm}$$



Product Service

Configuration 4 - EUT Stand Alone

Azimuth Angle (Degrees)	Elevation Angle (degrees)									
	10		20		30		40		50	
	EIRP dBm	Ant dBi	EIRP dBm	Ant dBi	EIRP dBm	Ant dBi	EIRP dBm	Ant dBi	EIRP dBm	Ant dBi
0	40.2	2.99	41.4	4.25	39.6	2.43	34.3	-2.90	23.4	-13.83
90	40.8	3.60	41.4	4.24	39.8	2.58	34.8	-2.42	24.6	-12.65
180	40.0	2.79	41.3	4.08	39.6	2.40	34.4	-2.76	23.3	-13.92
270	40.0	2.85	41.3	4.13	39.6	2.39	34.1	-3.07	21.7	-15.54

$$EIRP_{LOSS} = P_{t_{ambient}} - P_{t_{EOL}} = 37.2 - 37.37 = -0.17 \text{ dB}$$

$$EIRP_{maxEOL} = \text{Max}[EIRP_{max}, (EIRP_{max} - EIRP_{LOSS})] = \text{Max}[41.4, 41.6] = 41.6 \text{ dBm}$$

$$EIRP_{minEOL} = \text{Min}[EIRP_{min}, (EIRP_{min} - EIRP_{LOSS})] = \text{Min}[34.1, 34.3] = 34.1 \text{ dBm}$$



Product Service

2.8 BEACON CODING SOFTWARE

2.8.1 Specification

Cospas-Sarsat T.007, Clause A.2.8

2.8.2 Equipment Under Test and Modification State

Tron 40VDR S/N: 00001 VDR - Modification State 0

2.8.3 Date of Test

3 March 2014

2.8.4 Test Equipment Used

The major items of test equipment used for the above tests are identified in Section 3.1.

2.8.5 Environmental Conditions

Ambient Temperature 23.0 °C
Relative Humidity 34.0 %



Product Service

2.8.6 Test Results

Protocol	Operational Message		Self-Test Message	GNSS Self Test Message
	Location A	Location B		Location A
Standard Location: EPIRB with MMSI	FFFE2F8C92F423F133A03FFAC BF71DA4D4D0	FFFE2F8C92F423F132E0302E6A F78EA76951	FFFED08C92F423F17FDFF90DB 83783E0F66C	FFFED08C92F423F132E0302E6 AF78EA76951
Standard Location: EPIRB with Serial Number	FFFE2F8C96F9C06332E030B13 DF78EA76951	FFFE2F8C96F9C06333A03F659 CF71DA4D4D0	FFFED08C96F9C0637FDFF992E F3783E0F66C	FFFED08C96F9C06333A03F659 CF71DA4D4D0
Standard Location: Test	FFFE2F902EF9C04B32E02B4C4 9379C8051C4	FFFE2F902EF9C04B32E02B4C4 937908328CC	FFFED0902EF9C0017FDFFF3E4 EB783E0F66C	FFFED0902EF9C00133A039C93 D771DA4D4D0



Product Service

2.9 NAVIGATION SYSTEM TEST

2.9.1 Specification

Cospas-Sarsat T.007, Clause A.2.7

2.9.2 Equipment Under Test and Modification State

Tron 40VDR S/N: 00001 - Modification State 0
Tron 40VDR S/N: 00075 - Modification State 0

2.9.3 Date of Test

5 February 2014 & 20 February 2014

2.9.4 Test Equipment Used

The major items of test equipment used for the above tests are identified in Section 3.1.

2.9.5 Environmental Conditions

Ambient Temperature 13.6 °C – 22.3 °C
Relative Humidity 36.9 % – 51.3 %



2.9.6 Test Results

Standard Protocol

Position Data Default Values (C/S T.007 A.3.8.1):

No position data was provided for > 4 hours before the test started. The beacon was activated and operated for 30 minutes without providing data. Message content was checked for all bursts during this period.

36 Hex Message	Message Count
FF FED0902EF9C0017FDFFF3E4EB783E0F66C*	36
FF FE2F902EF9C0017FDFFF3E4EB783E0F66C	

* First message transmitted as Self-test

Position Acquisition Time and Position Accuracy (C/S T.007 A.3.8.2):

Locations:

A.3.8.2.1: 50° 52.121' N 1° 14.685' W ①

A.3.8.2.2: 51° 22.583' N 1° 49.833' W ②

The appropriate position was applied, the EUT activated and time to first message containing valid position data timed.

Configuration as per C/S T.007	C/S T.007 Section A.3.8.2.1		C/S T.007 Section A.3.8.2.2	
	Time to Acquire Position (sec)	Location Error in metres	Time to Acquire Position (sec)	Location Error in metres
Configuration 5*	55	31.3	55	49.8
Configuration 7*	55	60.9	55	49.8
Configuration 8*	55	60.9	55	49.8
Configuration 8**	106	60.9	152	49.8

Positional accuracy was calculated using the Haversine Formula, The Earth's radius was taken as 6367 km.

① GPS Site Survey – Live Location

② Input from GPS simulator

* EUT Stand alone

** EUT fitted into float free case



Product Service

Encoded Position Data Update Interval (C/S T.007 A.3.8.3):

Location: N 51° 22.583' W 1° 49.833' ①		
Data Acquired at	08:34:05	FFFE2F902EF9C00133A039C93D771DA4D4D0
Location: N 50° 48.683' W 1° 37.417' ①		
Data Updated at	8:41:33	FFFE2F902EF9C00132E0361D9C778EA76951
Data Update Interval	07 min 28 s	

① Input from GPS simulator

Position Clearance After Deactivation (C/S T.007 A.3.8.4):

Following the Encoded Position Data Update Interval test, the beacon was deactivated and reactivated without providing navigation data. The Digital Message output was encoded with the default position data.

Last Valid Position (C/S T.007 A.3.8.6):

Location: N 51° 22.583' W 1° 49.833' ①		
Data Acquired at	08:54:53	FFFE2F902EF9C00133A039C93D771DA4D4D0
GPS Signal Navigation Data Removed		
Data Updated at	12:55:11	FFFE2F902EF9C0017FDFFF3E4EB783E0F66C
Last Valid Position Held	240 min 18 s	
Return to Default Position	✓	

① Input from GPS simulator



Position Data Encoding (C/S T.007 A.3.8.7):

Results displayed as per C/S T.007 Issue 4 Revision 8 October 2013 – Table D.2

Script	Value of Encoded Location Bits Transmitted by Beacon	BCH Correct (✓)	Required Value of Encoded Location Bits
1. Navigation is not provided to the beacon.	Bits 65-85 = 0FFBFF Bits 113-132 = 83E0F	✓	Bits 65-85 = 0FFBFF Bits 113-132 = 83E0F
2. 0° 0 min 59 sec South 0° 0 min 57 sec West	Bits 65-85 = 100400 Bits 113-132 = 8420E Number of seconds after providing navigation data that beacon transmitted the above encoded location information: 48 s	✓	Bits 65-85 = 100400 Bits 113-132 = 8420E Response time for beacon to transmit correct encoded location must be less than 52.5 Sec.
3. 0° 0 min 53 sec North 0° 0 min 51 sec East	Bits 65-85 = 000000 Bits 113-132 = 8360D	✓	Bits 65-85 = 000000 Bits 113-132 = 8360D
4. 0° 11 min 10 sec North 179° 47 min 7 sec East	Bits 65-85 = 000ACF Bits 113-132 = 0F222	✓	Bits 65-85 = 000ACF Bits 113-132 = 0F222
5. 0° 34 min 55 sec North 179° 35 min 59 sec East	Bits 65-85 = 0012CE Bits 113-132 = 93A60	✓	Bits 65-85 = 0012CE Bits 113-132 = 93A60
6. 0° 11 min 3 sec South 179° 46 min 0 sec West	Bits 65-85 = 100ECF Bits 113-132 = 0FA10	✓	Bits 65-85 = 100ECF Bits 113-132 = 0FA10
7. 89° 15 min 8 sec South 89° 0 min 1 sec East	Bits 65-85 = 1B2964 Bits 113-132 = 80A00	✓	Bits 65-85 = 1B2964 Bits 113-132 = 80A00
8. 89° 16 min 10 sec South 89° 0 min 1 sec West	Bits 65-85 = 1B2D64 Bits 113-132 = 84E00	✓	Bits 65-85 = 1B2D64 Bits 113-132 = 84E00
9. 89° 59 min 4 sec North 179° 59 min 54 sec West	Bits 65-85 = 0B46D0 Bits 113-132 = 03801	✓	Bits 65-85 = 0B46D0 Bits 113-132 = 03801
10. 89° 57 min 59 sec North 179° 59 min 24 sec East	Bits 65-85 = 0B42D0 Bits 113-132 = 08009	✓	Bits 65-85 = 0B42D0 Bits 113-132 = 08009
11. 36° 30 min 0 sec South 138° 29 min 59 sec West	Bits 65-85 = 14962A Bits 113-132 = 80200	✓	Bits 65-85 = 14962A Bits 113-132 = 80200
Self-Test Navigation Test Scripts			
12. Navigation is not provided to the beacon.	Bits 65-85 = 0FFBFF Bits 113-132 = 83E0F	✓	Bits 65-85 = 0FFBFF Bits 113-132 = 83E0F
13. 0° 0 min 59 sec South 0° 0 min 57 sec West	Bits 65-85 = 0FFBFF Bits 113-132 = 83E0F	✓	Bits 65-85 = 0FFBFF Bits 113-132 = 83E0F

Test Script input from Tera Term software via TTL to the EUT's internal data interface.



Product Service

SECTION 3

TEST EQUIPMENT USED



3.1 TEST EQUIPMENT

List of absolute measuring and other principal items of test equipment.

Instrument	Manufacturer	Type No.	TE No.	Calibration Period (months)	Calibration Due
Section 2.1 – 2.5 Beacons - Constant Temperature Tests					
Power Meter	Hewlett Packard	436A	47	12	12-Jul-2014
Climatic Chamber	Heraeus Votsch	VM 04/100	85	-	O/P Mon
Rubidium Frequency Standard	Quartzlock	A10-B	92	12	30-Jan-2015
Time Interval Analyser	Yokogawa	TA720	181	12	25-Apr-2015
Signal Generator	Hewlett Packard	8644A	199	12	14-Apr-2015
Attenuator (10dB, 10W)	Weinschel	23-10-34	470	12	9-Oct-2014
Attenuator: 6dB/10W	Trilithic	HFP-50N	476	12	7-Aug-2014
Broadband Resistive Power Divider	Weinschel	1506A	601	12	21-Mar-2015
Signal Generator (100kHz to 2.6GHz)	Hewlett Packard	8663A	1063	12	8-Apr-2015
Spectrum Analyser	Agilent Technologies	E7405A	1410	12	27-Sep-2014
Distress Beacon RF Unit	TUV SUD Product Service	-	2445	-	TU
Beacon RF Unit	TUV SUD Product Service	N/A	3066	-	TU
Thermocouple Thermometer	Fluke	51	3172	12	21-Aug-2014
Bandpass Filter	Trilithic	5BE406/35-1-AA	3205	12	21-Aug-2014
Time Interval Analyser	Yokogawa	TA720 704510	3253	12	19-Nov-2014
ScopeCorder	Yokogawa	DL750 701210	3254	12	18-Nov-2014
Power Sensor	Agilent Technologies	8482A	3290	12	14-Jan-2015
Cable (1m, N Type)	Rhophase	NPS-1601-1000-NPS	3353	12	29-Apr-2015
Cable (1m, N Type)	Rhophase	NPS-1601-1000-NPS	3354	12	29-Apr-2015
Cable (2m, N Type)	Rhophase	NPS-1601-2000-NPS	3355	12	3-Dec-2014
Cable (2m, N Type)	Rhophase	NPS-1601-2000-NPS	3358	12	3-Dec-2014
ScopeCorder	Yokogawa	DL750	4175	12	29-Jan-2015
Section 2.10 Beacons - Navigation System					
Beacon Tester	WS Technologies	BT 100S	87	-	TU
GPS/SBAS Simulator	Spirent	STR4500	3056	-	TU
Copper GRP	TUV SUD Product Service	27cm Diameter	3538	-	TU
GPS Antenna	ACC	PA175-S	4228	-	TU



Product Service

Instrument	Manufacturer	Type No.	TE No.	Calibration Period (months)	Calibration Due
Section 2.6 Beacons - Operating Lifetime					
Power Meter	Hewlett Packard	436A	47	12	12-Jul-2014
Climatic Chamber	Heraeus Votsch	VM 04/100	85	-	O/P Mon
Time Interval Analyser	Yokogawa	TA720	181	12	22-Apr-2014
Attenuator (10dB, 10W)	Weinschel	23-10-34	470	12	9-Oct-2014
Signal Generator (100kHz to 2.6GHz)	Hewlett Packard	8663A	1063	12	3-Apr-2014
Spectrum Analyser	Agilent Technologies	E4407B	1154	12	13-Aug-2014
Attenuator (10dB, 10W)	Trilithic	HFP-50N	1377	12	17-Oct-2014
Hygrometer	Rotronic	I-1000	1386	12	18-Apr-2014
Beacon RF Unit	TUV SUD Product Service	N/A	3066	-	TU
Termination (50ohm, 2W)	Omni-Spectra	3001-6100	3081	12	4-Mar-2014
Attenuator (20dB, 10W)	Aeroflex / Weinschel	23-20-34	3158	12	27-Jun-2014
Attenuator (3dB, 20W)	Aeroflex / Weinschel	23-03-34	3163	12	12-Sep-2014
Thermocouple Thermometer	Fluke	51	3172	12	21-Aug-2014
Bandpass Filter	Trilithic	5BE406/35-1-AA	3207	12	21-Aug-2014
ScopeCorder	Yokogawa	DL750 701210	3254	12	18-Nov-2014
Power Sensor	Agilent Technologies	8482A	3290	12	14-Jan-2015
Cable (1m, N Type)	Rhophase	NPS-1601-1000-NPS	3351	12	19-Apr-2014
Cable (1m, N Type)	Rhophase	NPS-1601-1000-NPS	3354	12	19-Apr-2014
Bandpass Filter	Trilithic	5BE121.55/35-3-BA	3410	12	12-Sep-2014
'N' - 'N' RF Cable (1m)	Rhophase	NPS-1803-1000-NPS	3700	12	26-Nov-2014
Section 2.7 Beacons - Satellite Qualitative Test					
Beacon Tester	WS Technologies	BT 100S	87	-	TU
Beacon Tester	WS Technologies	BT100S	3263	-	TU
Humidity and Temperature Meter	R.S Components	1361C	3844		22-Mar-2014
Humidity & Temperature Meter	Radio Spares	1361C	4420	12	1-May-2015
Copper GRP	TUV SUD Product Service	27cm Diameter	3538	-	TU
Section 2.3 Beacons - Spurious Emissions					
Rubidium Frequency Standard	Quartzlock	A10-B	92	12	30-Jan-2015
Spectrum Analyser	Rohde & Schwarz	FSU26	2747	12	15-Nov-2014
Attenuator (20dB, 10W)	Aeroflex / Weinschel	23-20-34	3159	12	4-Jun-2015
Attenuator (3dB, 20W)	Aeroflex / Weinschel	23-03-34	3163	12	12-Sep-2014
Cable (1m, N Type)	Rhophase	NPS-1601-1000-NPS	3352	12	29-Apr-2015
Cable (2m, N Type)	Rhophase	NPS-1601-2000-NPS	3355	12	3-Dec-2014

TU – Traceability Unscheduled

OP MON – Output Monitored with Calibrated Equipment



Product Service

SECTION 4

PHOTOGRAPHS

4.1 PHOTOGRAPHS OF EQUIPMENT UNDER TEST (EUT)



Front View



Test Configuration



Configuration 5 – Standalone



Configuration 7 – Standalone



Configuration 8 – Standalone



Configuration 8 – In Float Free Case

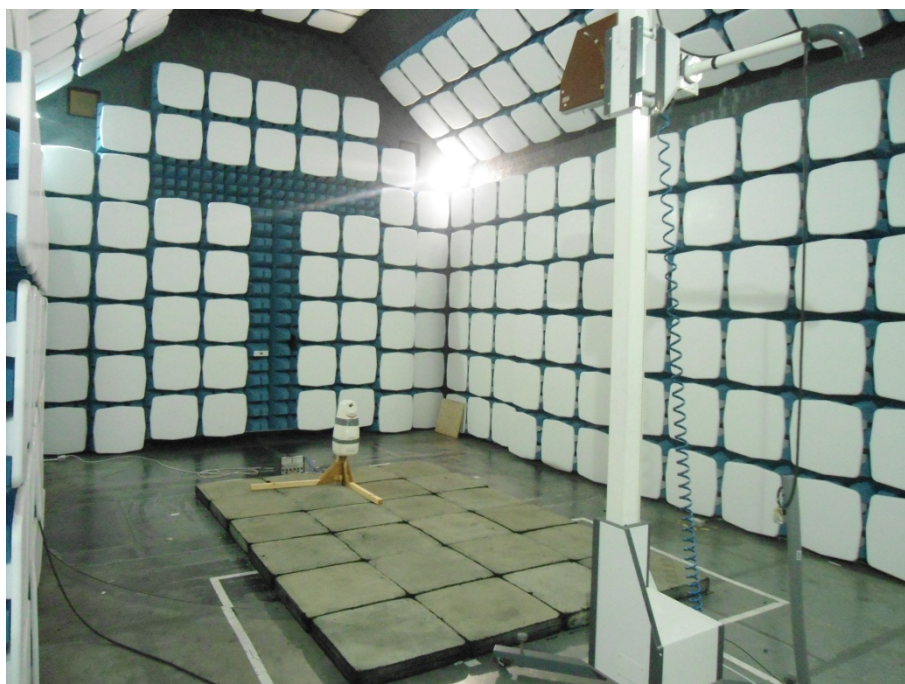

Configuration 4 – In Float Free Case

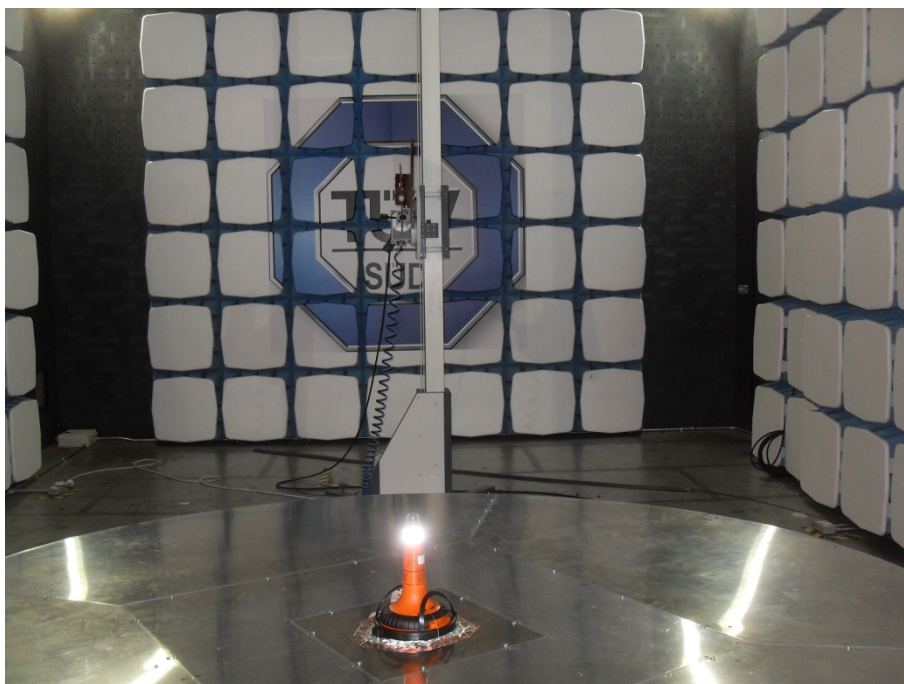

Configuration 1 – Standalone

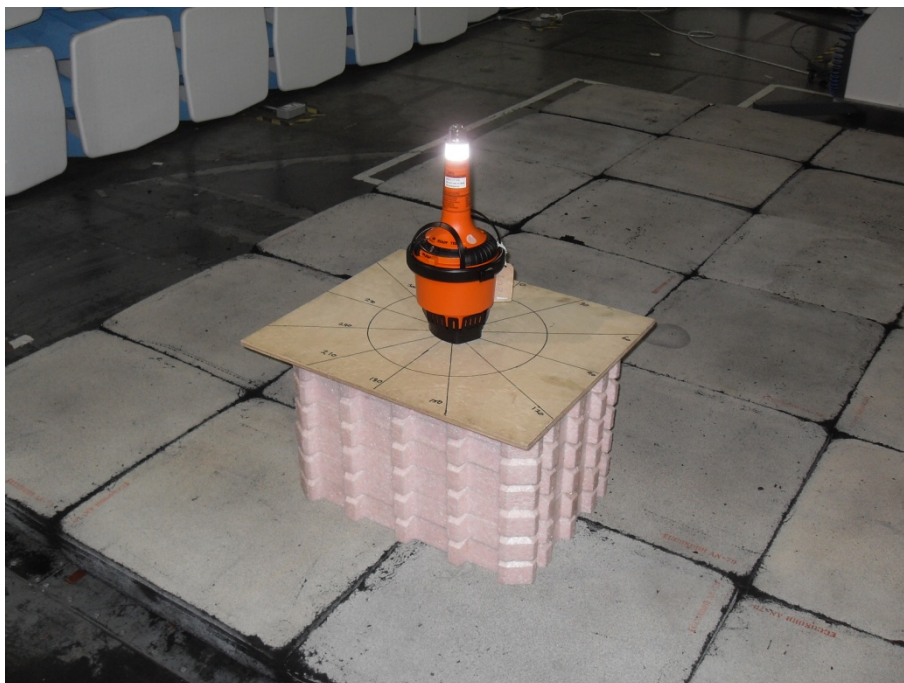

Configuration 4 – Standalone



Product Service

SECTION 5

ACCREDITATION, DISCLAIMERS AND COPYRIGHT



Product Service

5.1 ACCREDITATION, DISCLAIMERS AND COPYRIGHT



This report relates only to the actual item/items tested.

Our UKAS Accreditation does not cover opinions and interpretations and any expressed are outside the scope of our UKAS Accreditation.

Results of tests not covered by our UKAS Accreditation Schedule are marked NUA (Not UKAS Accredited).

This report must not be reproduced, except in its entirety, without the written permission of TÜV SÜD Product Service

© 2014 TÜV SÜD Product Service



Product Service

ANNEX A

CUSTOMER SUPPLIED INFORMATION



Product Service

Jotron AS
Jotron UK Ltd.
Jotron Phontech AS
Jotron Consultas AS
Jotron Asia Pte. Ltd.
Jotron USA, Inc.
UAB Jotron



Tron 40VDR

Loss in antenna matching network

Background:

Measuring of output power on 406MHz is done both in 50 ohm connector and radiated. The output power differs due to loss in antenna matching network. This network is bypassed on the unit with 50 ohm connector and therefore the measurements have to be corrected to match the radiated power.

This document describes the correction factor to subtract to the measurements done in the 50 ohm connector.

Reason:

D6 and FB4 have to be removed on the unit with connector, and with it also the antenna matching network and the output filter for the 121.5MHz transmitter. This leads to a higher output power in the connector than what reaches the antenna.

Scope:

This applies to the 406MHZ connector on Tron 40VDR.

Conclusion:

1.78dB has to be subtracted from the measurements done in the 50 ohm connector.

DNB Nor Bank ASA | 0021 Oslo | Norway | Bank account: 24400508514 | IBAN: NO6624400508514 | BIC: DNBNOK33 | Reg.no.: NO917713324 MVA
QA Certificate: NS-EN ISO 9001:2008

www.jotron.com

Jotron AS
P.O. Box 54 | NO-3281 Tjodalving | Norway

Tel: +47 33 13 97 00
Fax: +47 33 12 67 80

Tron 40VDR

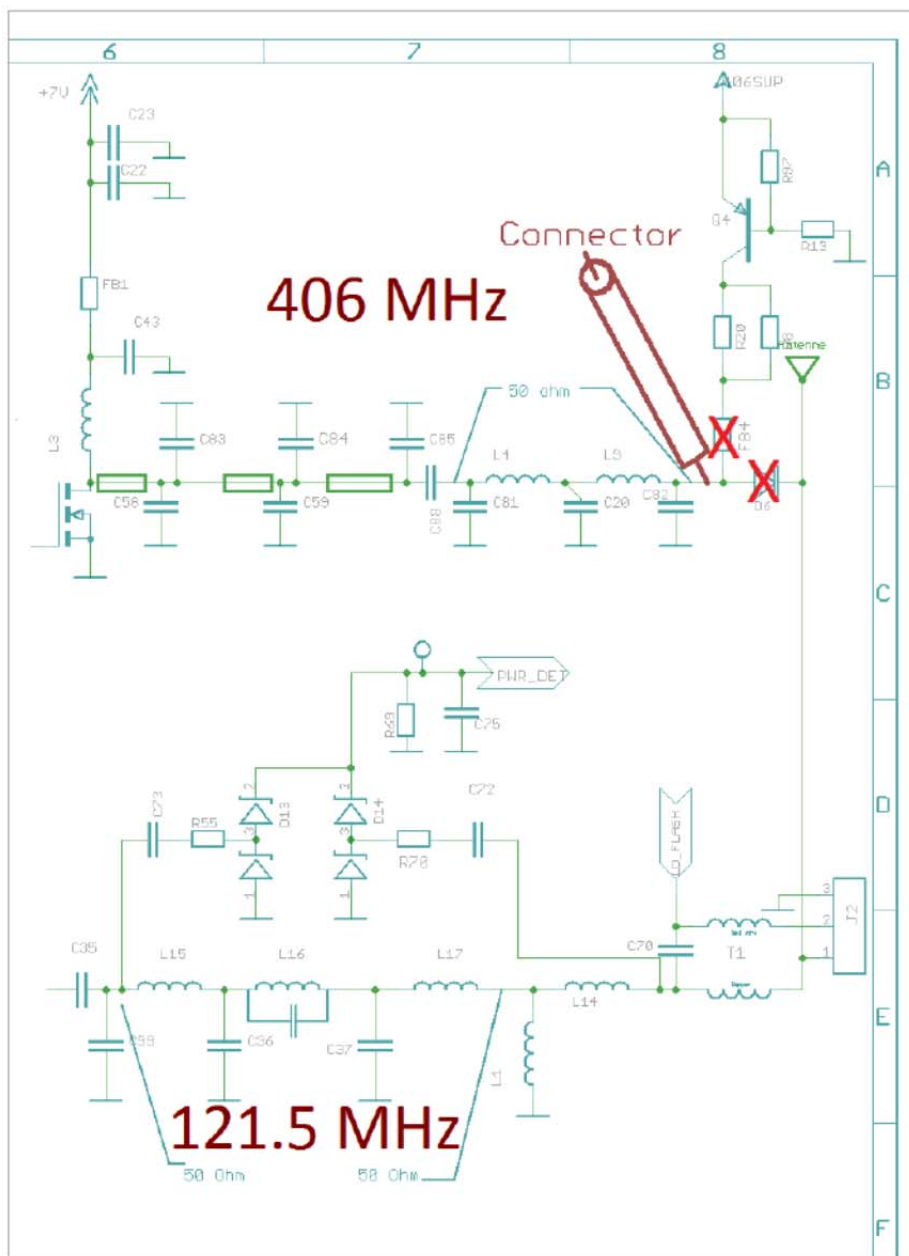

Figure 1: Modification for 50 ohm connector



Tron 40VDR

Measurement:

One problem is that the EPIRB antenna (connected to J2) is not 50 ohm and therefore we need an impedance transformer to measure the loss. Another EPIRB is used to solve this issue. The two EPIRBs are connected together via the antenna connector J2 (blue lines in Figure 2). The ideal solution would be to measure from the 50 ohm connector, but as this point only is 50 ohm when you remove D6 and FB4, this is not possible. The solution is to include the output filter in the measurement and then subtract them afterwards.

The measurement is done with a network analyzer.

Loss between Port1 and Port2: 3.42dB

Loss in each output filter: 0.12dB

Total loss without output filters: $(3.42 - 2 \times 0.12) = 3.18$

Loss for one EPIRB: $3.18 : 2 = 1.59\text{dB}$.

The network analyzer is measuring at 0dBm and the loss in D6 is increasing with the power. A new measurement is done with a generator at +38dBm and a power meter.

This gives **1.78dB** at +38dBm.

Tron 40VDR

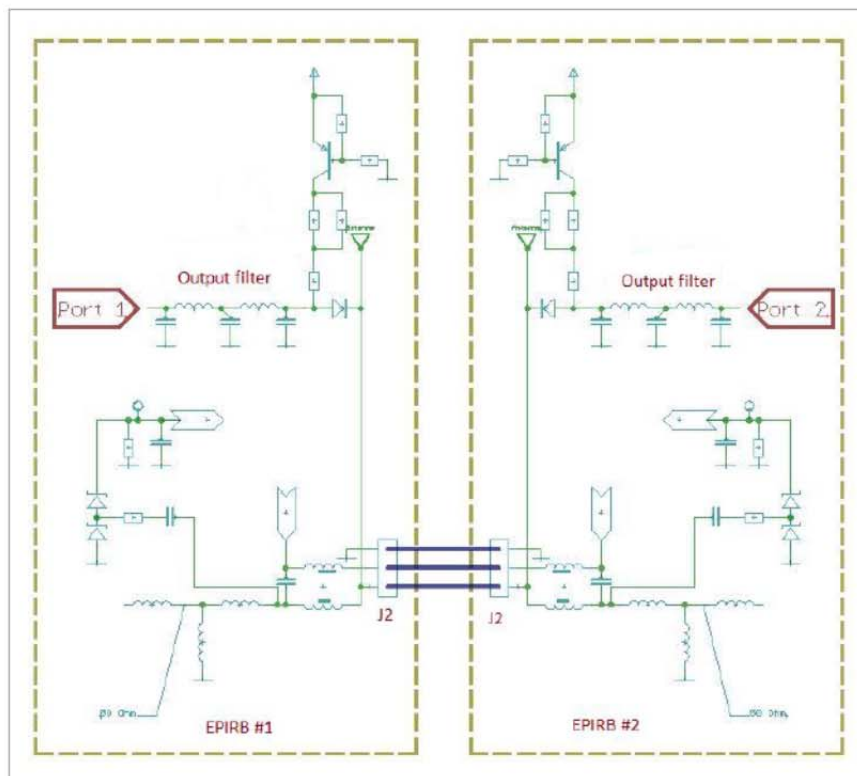

Figure 2: Measurement setup

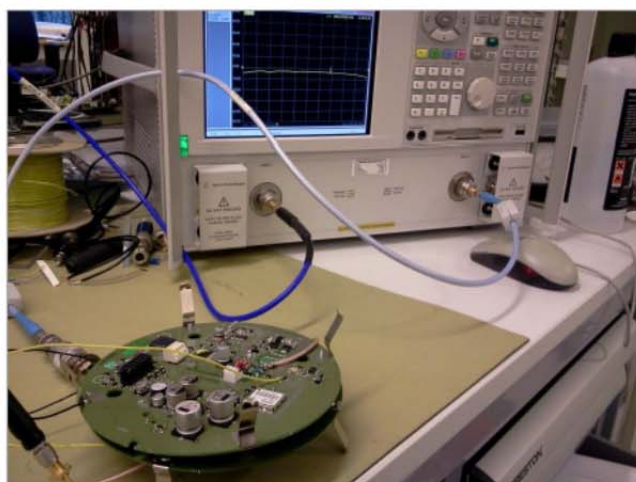

Figure 3: Picture of test setup



Product Service

Tron 40VDR

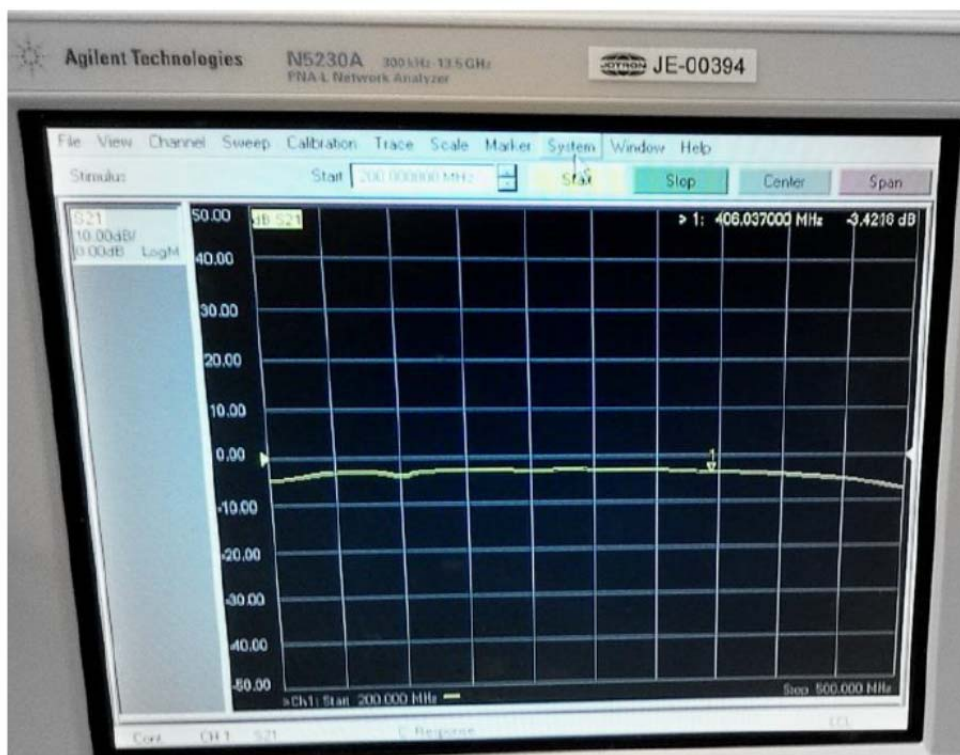

Figure 4: Readout from the network analyser



Product Service

Jotron AS
Jotron UK Ltd.
Jotron Phontech AS
Jotron Consultas AS
Jotron Asia Pte. Ltd.
Jotron USA, Inc.
UAB Jotron



Tron 40VDR

Protection From Repetitive Self-Test Mode Transmissions

In self-test, the beacon is powered by a separate test switch, and a TEST signal will activate the self-test routine. After the microcontroller has performed the self-test routine, the microcontroller turns off all electrical circuits. Then the program runs in a wait loop until the TEST switch is released. Please see figure below.

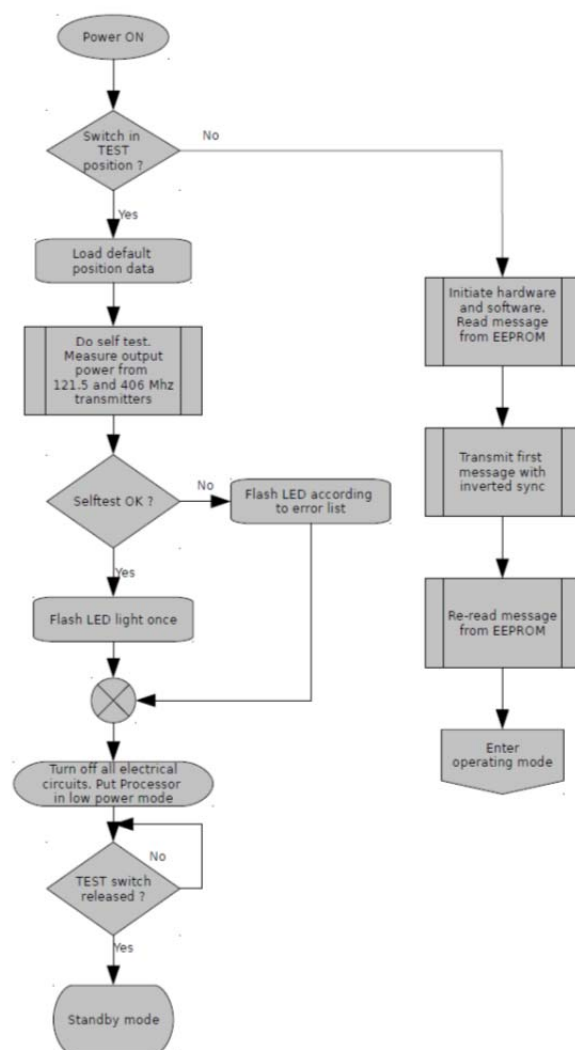

Figure 1: Selt-Test flowchart

February 25 2014

Page 1 of 2



Tron 40VDR

GNSS Self-Test limited in number

GNSS Self-Test is activated by moving the switch to TEST-position twice within 3 seconds and released back to READY position. If more than allowed GNSS Self-Test's is already executed, this will be announced by 10 beep's and the EPIRB will power off.

If more GNSS Self-Test's is allowed, the counter is increased, a 120 seconds timer is started and the GNSS is switched on. If position is received before the timer stops, then a normal Self-Test is executed and the position is transmitted in the 406 message. The EPIRB power's off. In case of no position within the time limit, this will be announced by 5 beep's and the EPIRB will power off.

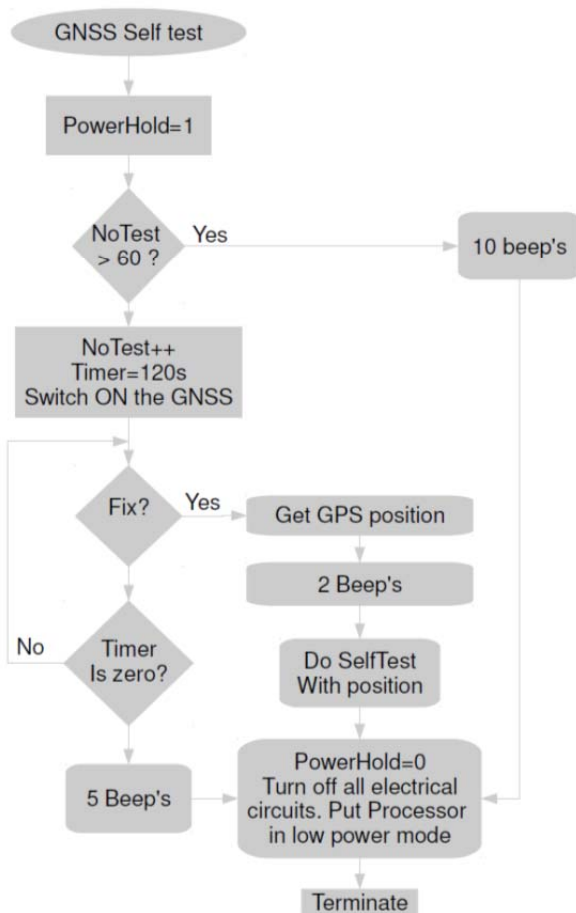

Figure 2: GNSS Self-Test flow chart



Product Service

Jotron AS
Jotron UK Ltd.
Jotron Phontech AS
Jotron Consultas AS
Jotron Asia Pte. Ltd.
Jotron USA, Inc.
UAB Jotron



Tron 40VDR

Change description for loop filter

Problem:

During type approval with Cospas Sarsat there was problem with the modulation of 406MHz. The modulation exceeded its limits due to noise and spikes.

Reason:

Ripple and phase noise on the modulation signal makes the modulation level exceed the limits. The response in the loop is not fast enough to give a good and steady regulation of the modulation frequency.

Scope:

This problem only applies to modulation on 406MHz.

Solution:

The loop filter on the frequency synthesizer has been tuned for better performance. The bandwidth is increased and the response is therefore faster and more accurate. This makes better suppression of noise and ripple. See highlighted components in electrical schema in Figure 1.

Changes:

- C10 is reduced from 68n to 22n.
- R21 is reduced from 3k3 to 680R.
- C14 is increased from 330p to 1200p
- C55 is reduced from 470p to 220n
- R41 is reduced from 5k6 to 3k6

In addition we have changed the same capacitors to one with better temperature coefficient (X7R) to improve the performance in high and low temperature.

DNB Nor Bank ASA | 0021 Oslo | Norway | Bank account: 24400508514 | IBAN: NO6624400508514 | BIC: DNBNOKK | Reg.no: NO917713324 MVA
QA Certificate: NS-EN ISO 9001:2008

www.jotron.com

Jotron AS
P.O. Box 54 | NO-3281 Tjodalving | Norway

Tel: +47 33 13 97 00
Fax: +47 33 12 67 80

Tron 40VDR

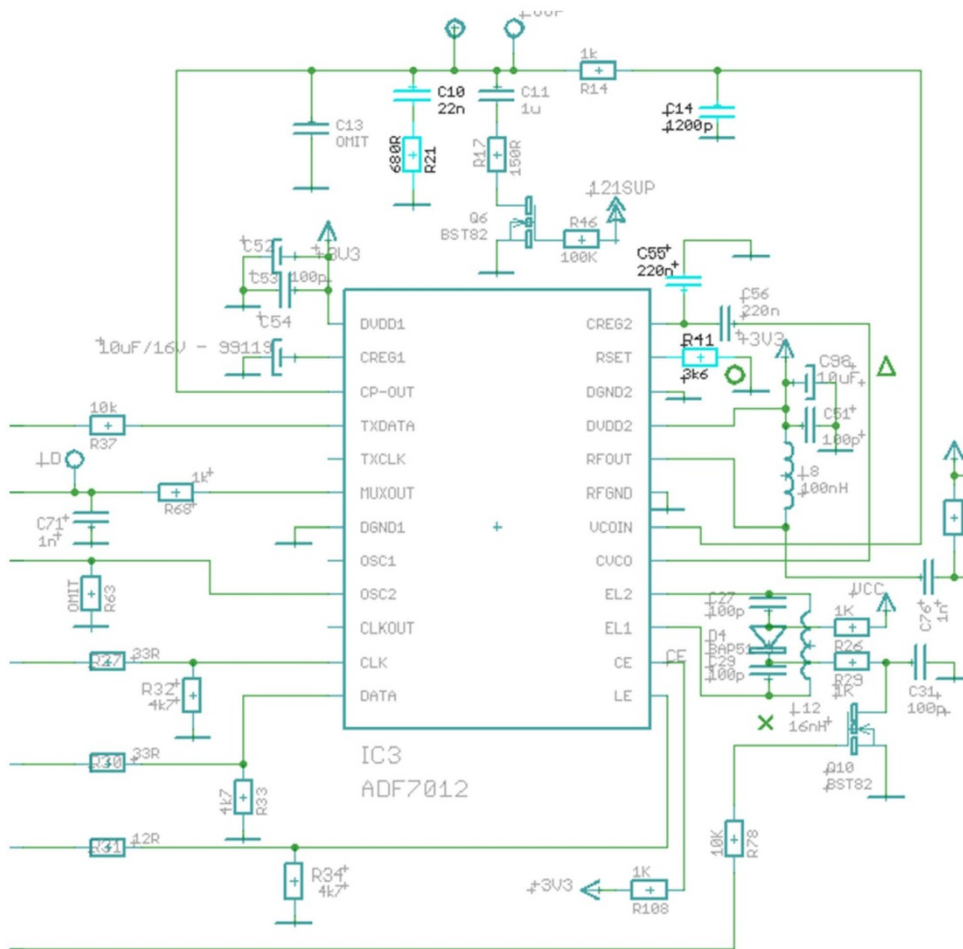

Figure 1: Loop filter