

USERS MANUAL



Tron 40GPS MkII



www.jotron.com



EC Declaration of Conformity, available at www.jotron.com

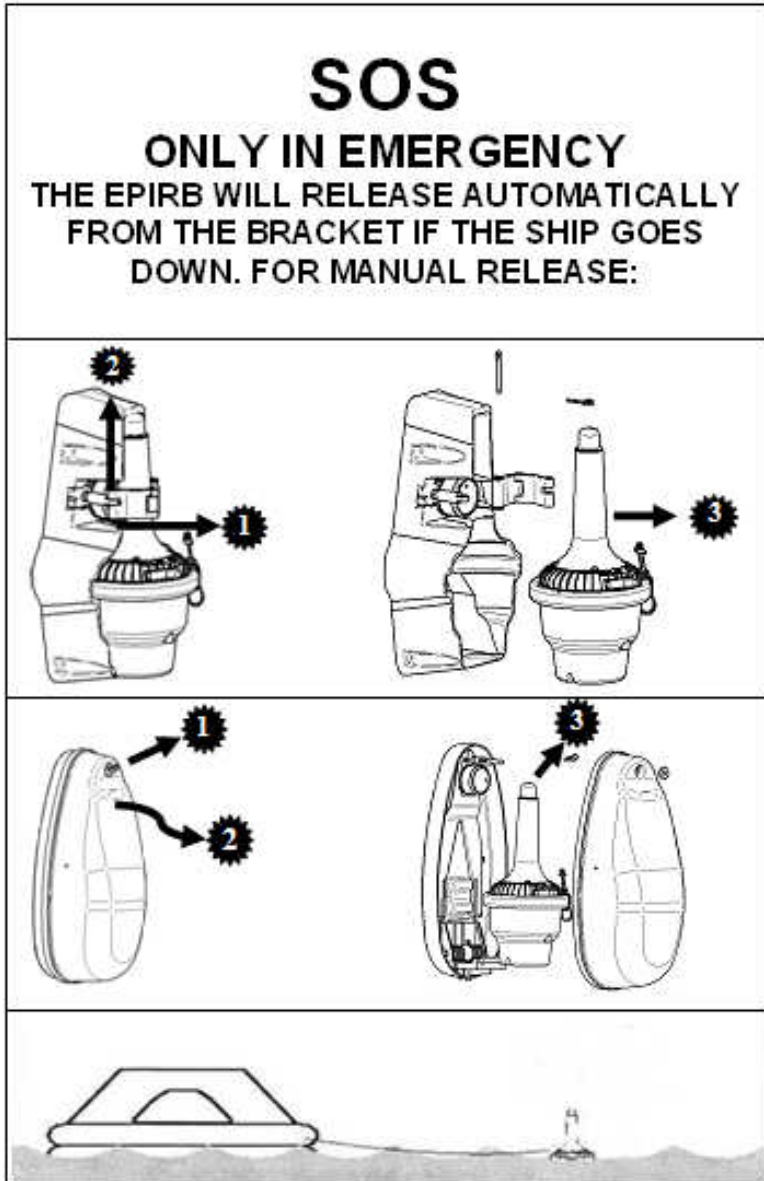



IMPORTANT

TO PERMANENTLY DISABLE EPIRB

The battery module must be removed and treated according to chapter 6.1.2 paragraph 1, 2, 3 and 4, chapter 6.1.3, 6.1.4, 1.1.1 and 6.1.6 in this manual.

WARNING

USE ONLY THIS EPIRB DURING SITUATIONS OF GRAVE AND IMMINENT DANGER

FALSE ALERTS

DE-ALERTING SAR FORCES IN EVENT OF INADVERTENT ACTIVATION, OR ASSISTANCE NO LONGER REQUIRED

FALSE ALARMS DIVERT RESCUE FORCES FROM REAL DISTRESS SITUATIONS. **Intentional false alerts may result in penalties.** RESPONDING TO FALSE ALARMS COSTS MILLIONS ANNUALLY. WE NEED YOUR HELP:

- 1. REMEMBER: ACTIVATING YOUR BEACON IS THE EQUIVALENT OF TRANSMITTING A MAYDAY.**
- 2. FOLLOW MANUFACTURER PROCEDURES WHEN TESTING YOUR BEACON.**
- 3. IF YOUR BEACON IS ACTIVATED**
 - IN A NON-DISTRESS SITUATION, OR**
 - IN A DISTRESS SITUATION, WHICH RESOLVES, AND YOU NO LONGER REQUIRE ASSISTANCE;**

CONTACT THE NEAREST SAR AUTHORITIES VIA THE MOST EXPEDITIOUS MEANS AVAILABLE WITH THE FOLLOWING INFORMATION:



Beacon ID number (15 character UIN):

Position (at time of activation):

Date of Activation:

Time of Activation (Time zone):

Duration of Activation:

Beacon make and model:

Vessel Name/ID:

Circumstances/cause (if known):

**PRIMARY U.S. POINT OF CONTACT IS THE U.S. COAST GUARD:
PASS BY MOST EXPEDITIOUS, DIRECT MEANS TO**

FOR THE PACIFIC:

PACIFIC AREA COMMAND CENTER (510) 437 3700

FOR THE ATLANTIC/GULF OF MEXICO/ATLANTIC:

ATLANTIC AREA COMMAND CENTER (757) 398-6390

OR FROM ANY LOCATION:

(800) 323 SAFE
(800) 323 7233



The information in this book has been carefully checked and is believed to be accurate. However, no responsibility is assumed for inaccuracies.



This equipment contains CMOS integrated circuits. Observe handling precautions to avoid static discharges which may damage these devices. Jotron AS reserves the right to make changes without further notice to any products or modules described herein to improve reliability, function or design. Jotron AS does not assume any liability arising out of the application or use of the described product.

WARNING / IMPORTANT

Jotron AS is a prime manufacturer of safety equipment designed for rescue of human lives and their property. For safety equipment to be effective in line with the design parameters it is important that they are handled, stowed and maintained in compliance with the manufacturers instructions. Jotron AS can not be held responsible for any damage caused due to incorrect use of the equipment or breach of laid down procedures or for failure of any specific component or other parts of the equipment.

The chapter covering battery replacement (6.1.2) is added for information only. Jotron AS does not take any responsibility for improper disassembling/assembling of the beacon. We strongly recommend all service to be done by authorized Jotron AS agents. In addition to normal service, Jotron AS agents have the necessary equipment and education to test the operational functions of the beacon. Non-original maintenance and/or service parts may destroy the equipment function and performance.



WARRANTY

All goods sold by Jotron AS are warranted to be free from defect in workmanship and material for the period of twenty-four (24) months from the date of delivery (unless stated otherwise and confirmed in writings).

PROVIDED:

- (a) Jotron AS is given full particulars in writing of any claim prior to the expiration of such a period and within fourteen days of the discovery of the alleged defect.
- (b) The goods have stored, installed, maintained and used properly having regard in particular to Jotron AS specifications.
- (c) Liability shall be limited at Jotron AS options to replacement or repair or to a sum not exceeding the net invoice value of the defective goods.
- (d) Upon request the alleged faulty goods are returned to Jotron AS at the Buyer's expense.
- (e) Unless expressly stipulated in the acceptance of the order Jotron AS gives no warranty or guarantee of the fitness or suitability of the goods for any purpose whether disclosed or otherwise.
- (f) All other warranties or conditions expressed or implied are hereby excluded and Jotron AS shall in no circumstances be liable for consequential damages.



Abbreviations and definitions

BAUD

Transmission rate unit of measurement for binary coded data (bit per second).

BIT

Short form of Binary Digit. The smallest element of data in a binary-coded value.

BITE

Built in test equipment

BPS

Bits Per Second.

CHARACTER STRING

Continuous characters (other than spaces) in a message.

CHECKSUM

The value sent with a binary-coded message to be checked at the receiving end to verify the integrity of the message.

COSPAS

COsmicheskaya Sistyema Poiska Avaryynich Sudov (Space System for the Search of Vessels in Distress)

CLOCK

A precisely spaced, stable train of pulses generated within an electronic system to synchronize the timing of digital operations within the system.

DEFAULT

The operator initiates a condition that the navigator assumes automatically if no other condition.

EPIRB

Emergency Position Indicating Radio Beacon



GLOBAL POSITIONING SYSTEM (GPS)

The NAVSTAR Global Positioning System, which consists of orbiting satellites, a network of ground control stations, and user positioning and navigation equipment. The system has 24 satellites plus 3 active spare satellites in six orbital planes about 20,200 kilometers above the earth.

GPS

Global Position System

GPS SYSTEM TIME

Time corrected to Universal Time Coordinated (UTC) and used as the time standard by the user segment of the GPS system.

IEC

International Electro-technical Commission.

IMO

International Maritime Organization

INTERFACE

Electronic circuits that permit the passage of data between different types of devices; For example, the speed and heading interface circuit permits data from a speed log and compass to pass to the navigator processor.

ITU

International Telecommunication Union.

LED

Light Emitting Diode.

LUT

Local User Terminal (Ground Station).

MCC

Mission Control Centre.

PROCESSOR

The processor circuit card in the console that controls system operations and computes the positioning/navigation solutions.



RCC

Rescue Coordination Centre.

SARSAT

Search and Rescue Satellite-Aided Tracking System.

SBM

Shore Based Maintenance – as required by SOLAS regulation IV/15.9.2 of SOLAS 1974 as amended with, in accordance with MSC/Circ. 1039 guidelines for Shore-Based Maintenance (SBM) of Satellite EPIRBs within 5 years if:

Passenger ships (> 12 passengers) and cargo ships (> 300GT) engaged in International voyages, shall perform SBM as follows:

- Latest by the date of the EPIRB label with this text, or the battery Label, whichever is first.
- When this EPIRB becomes due for SBM in accordance with national requirements.

SOFTWARE

Values programmed and preloaded into memory. The values represent a permanent set of instructions for running the automatic functions (computations) of the navigator.

VHF

Very High Frequency -A set of frequencies in the MHz region.

VSWR

Voltage standing wave ratio



Amendment Record

| AMENDMENT NO. | INCORP. BY | DATE | PAGE(S) | VERSION | REASON FOR CHANGE |
|---------------|------------|----------|-----------|---------|-------------------|
| 1 | ES | 05.01.07 | Total 36 | A | New manual |
| 2 | ES | 12.04.07 | Total 36 | B | New company |
| 3 | ES | 31.08.07 | 27 | C | Error |
| 4 | ES | 31.01.08 | 21 and 22 | D | Man. operation |
| 5 | ES | 25.02.08 | 2-6,26,30 | E | Added text |
| 6 | | | | | |
| 7 | | | | | |
| 8 | | | | | |
| 9 | | | | | |
| 10 | | | | | |
| 11 | | | | | |
| 12 | | | | | |
| 13 | | | | | |
| 14 | | | | | |
| 15 | | | | | |
| 16 | | | | | |
| 17 | | | | | |



TABLE OF CONTENTS

| | | |
|----------|--|-----------|
| 1 | GENERAL DESCRIPTION | 16 |
| 1.1 | TRON 40GPS MkII | 16 |
| 1.2 | SYSTEM DESCRIPTION | 17 |
| 1.2.1 | SIGNAL DETECTION | 17 |
| 1.2.2 | DISTRESS LOCATION DETERMINATION | 18 |
| 1.2.2.1 | GPS ADVANTAGE | 18 |
| 1.2.3 | EPIRB REGISTRATION | 18 |
| 2 | TECHNICAL SPECIFICATIONS | 20 |
| 2.1 | GENERAL | 20 |
| 2.2 | COSPAS/SARSAT TRANSMITTER | 20 |
| 2.3 | NAVIGATION DEVICE | 20 |
| 2.4 | HOMING TRANSMITTER | 21 |
| 2.5 | BRACKETS | 21 |
| 3 | FUNCTIONAL DESCRIPTION | 22 |
| 3.1 | GENERAL | 22 |
| 3.1.1 | EPIRB MODULE WITH ANTENNA | 22 |
| 3.1.2 | BATTERY MODULE | 23 |
| 3.1.3 | EQUATOR RING WITH GASKET | 23 |
| 4 | INSTALLATION | 23 |
| 4.1 | BRACKETS | 23 |
| 4.1.1 | FLOAT FREE BRACKET FB5 AND FB4 | 24 |
| 4.1.2 | FLOAT FREE BRACKET FBH4 | 24 |
| 4.1.3 | MANUAL BRACKET MB5 AND MB4 | 24 |
| 4.1.4 | MOUNTING THE FB5/MB5/FB4/FBH4/MB4 BRACKETS | 25 |
| 5 | OPERATION INSTRUCTIONS | 25 |
| 5.1 | MANUAL OPERATION | 25 |
| 5.2 | AUTOMATIC OPERATION (FB4/FBH4/FB5) | 26 |
| 5.3 | MANUAL TEST OF THE EPIRB | 26 |
| 6 | MAINTENANCE AND TROUBLESHOOTING | 27 |
| 6.1 | EPIRB MODULE / BATTERY MODULE | 27 |
| 6.1.1 | CHANGE OF BATTERY | 27 |
| 6.1.2 | REPLACING THE BATTERY MODULE | 27 |



| | | |
|----------|---|-----------|
| 6.1.3 | BATTERY DISPOSAL | 28 |
| 6.1.4 | INCINERATION | 28 |
| 6.1.5 | LAND FILLING | 29 |
| 6.1.6 | RECYCLING | 29 |
| 6.2 | HYDROSTATIC RELEASE REPLACEMENT | 29 |
| 6.2.1 | REPLACING THE RELEASE MECHANISM IN FB4/FBH4 BRACKET | 29 |
| 6.2.2 | REPLACING THE RELEASE MECHANISM IN FB5 BRACKET | 30 |
| 6.3 | TRON 40GPS MKII SELF TEST | 30 |
| 6.4 | MAINTENANCE OF EPIRB | 31 |
| 6.5 | EPIRB ERROR MESSAGES | 31 |
| 7 | FIGURES | 32 |
| 7.1 | SIGNAL DETECTION | 32 |
| 7.2 | MANUAL OPERATION | 33 |
| 7.3 | AUTOMATIC OPERATION | 34 |
| 7.4 | SELF TEST | 34 |
| 7.5 | REPLACING THE RELEASE MECHANISM IN FB4/FBH4 BRACKET | 35 |
| 7.6 | REPLACING THE RELEASE MECHANISM IN FB5 BRACKET | 35 |
| 7.7 | REPLACING THE BATTERY MODULE | 36 |
| 7.8 | MOUNTING OF BRACKETS | 38 |
| 8 | SERVICE AGENTS | 39 |



BATTERY SAFETY DATA SHEET

(Form: EEC directive 91/155)

(2) SAFETY ADVICE

- S2 Keep out of reach of children.
- S8 Keep container dry.
- S26 In case of contact with eyes, rinse immediately with plenty of water and seek medical advice.
- S43 In case of fire, use D type extinguishers. Never use water.
- S45 In case of accident or if you feel unwell, seek medical advice immediately (show the label where possible).

(3) FIRST AID MEASURES

In case of contact of cell contents with eyes, flush immediately with water for 15 min. With skin, wash with plenty of water and take off contaminated clothes. If inhaled, remove from exposure, give oxygen, seek medical advice.

(4) FIRE-FIGHTING MEASURES

Extinguishing media

Suitable: Type D fire extinguishers

Not to be used: Water - CO₂ - Halon, dry chemical or foam extinguishers

Special exposure hazards

Generation of chlorine, sulphur dioxide, disulphur dichloride during thermal decomposition.

Special protective equipment

Use protective working boots, rubber apron and safety glasses with side shields.



**INSTRUCTIONS FOR KEEPING THE RADIO LOG AND THE RADIO OPERATORS
OBLIGATION ACCORDING TO NATIONAL AND INTERNATIONAL REGULATION.**

1. The radio log shall be kept in accordance with requirements in the Radio Regulations, SOLAS Convention, national regulations regarding radio installations and the STCW Convention (STCW 95 including the STCW Code) including the relevant regulation regarding watch keeping on board passenger and cargo ships.
2. Unauthorized transmissions and incidents of harmful interference should, if possible, be identified, recorded in the radio log and brought to the attention of the Administration in compliance with the Radio Regulations, together with an appropriate extract from the radio log. (STCW Code B-VIII/2 No.32)

TEST OF RADIO EQUIPMENT AND RESERVE SOURCE OF ENERGY

Monthly:

Float-free and manual EPIRBs to be checked using the means provided for testing on the equipment.
Check data for periodical maintenance requirement for float-free EPIRB search and rescue radar transponders (SART) to be checked against 9 GHz radar.



1 GENERAL DESCRIPTION

The Tron 40GPS MkII is emergency equipment consisting of:

- Tron 40GPS MkII COSPAS/SARSAT emergency EPIRB
- One of the following brackets:

FB4 - Automatic float free bracket.

FBH4 - Automatic float free bracket v/heating.

MB4 - Manual bracket.

MB5 - Manual bracket.

FB5 - Automatic float free bracket.

The Tron 40GPS MkII EPIRB is developed to meet the regulations and rules for use on vessels and life rafts in the maritime service. Tron 40GPS MkII meets the following specifications for 406 MHz EPIRBs for use in search and rescue operations at sea:

IEC 61097-2

IEC 60945

MSC/Circ 862

C/S T.001

IMO A662(16)

IMO A696 (17)

IMO A810 (19)

DIR 96/98 EEC

1.1 TRON 40GPS MkII

The Tron 40GPS MkII is buoyant, and is designed to automatically release and activate in case of an emergency where the EPIRB and its bracket is submerged into the sea. The Tron 40GPS MkII can also be operated as a manual EPIRB, by manually releasing it from its bracket and then activating it.

Five different brackets are currently available for the Tron 40GPS MkII. MB4 and MB5 are the manual bracket and FB4 and FBH4 is the automatic bracket. FB5 is automatic bracket with cover. The manual bracket comes without the hydrostatic release mechanism and is used to store the beacon inside the wheelhouse or other protected places. The automatic bracket is mounted in a free space outside where the beacon can be released automatically.

The purpose of the Tron 40GPS MkII is to give a primary alarm to the search and rescue authorities. The EPIRB gives an immediate alarm when activated, transmitting the ID of the ship in distress. Care must be taken not to activate the EPIRB unless in an emergency situation, in such cases the user will be held responsible. For periodic testing a test function is implemented. During the test cycle the EPIRB does a self-test on the transmitters and on the battery status. No emergency signal is transmitted during the self-test.

The battery of the EPIRB will last for at least 48 hours from activation of the EPIRB.



1.2 SYSTEM DESCRIPTION

The COSPAS/SARSAT system was introduced in 1982 as a worldwide search and rescue system with the help of satellites covering the earth's surface. Since the introduction of the system more than 20531 persons have been rescued by the COSPAS/ SARSAT system (2005). Currently the system consists of 5 functional satellites in a polar orbit constellation, these satellites cover the entire earth's surface and receive the emergency signal from the 406 MHz transmitter within the Tron 40GPS MkII, more polar orbiting satellites will be available in the future, giving a faster location and rescue time.

In addition several geostationary satellites are equipped with a 406 MHz transponder, these satellites are not able to locate the Tron 40GPS MkII but will give an early warning to the rescue forces, minimising the time from an emergency occurs till the rescue forces are at the site.

Each emergency EPIRB in the system is programmed with its own unique code, therefore it is vital that the ships data that is given to the dealer you obtained your Tron 40GPS MkII, is correct. It is also important that your EPIRB is registered in the database for each country. This database is normally located in the same country that the ship is registered.

1.2.1 SIGNAL DETECTION

See figure 7.1.a

When the Tron 40GPS MkII is activated (manually or automatically) it transmits on the frequencies 121.5 MHz and 406.037 MHz. An analogue signal is emitted on 121.5 MHz and a digital signal is transmitted on 406.037 MHz. After the Tron 40GPS MkII is activated, the next passing satellite will detect the transmitted signal and relay it to an antenna at a ground station, called an LUT.

For the 121.5 MHz signal the satellite must be within line of sight of both the Tron 40GPS MkII and a ground station. The ground station or LUT has a 2500 km satellite reception radius centred at the LUT. In areas without LUT coverage (mostly less populated areas in the southern hemisphere), signals from the 121.5 MHz transmitter will not be detected by the satellites, only by passing aircraft's. This is not the case with the 406 MHz transmitter, because the satellites have a memory unit, which stores the signals for relay to the next available LUT giving it a truly global coverage. Once the signal is received by the LUT, it is processed for location and sent to a Mission Control Centre (MCC). The MCC sorts the alert data according to geographic search and rescue regions and distributes the information to the appropriate Rescue Co-ordination Centre (RCC), or if outside the national search and rescue area, to the appropriate MCC that covers the area where the distress signal was detected. The RCC in turn takes the necessary action to initiate search and rescue activities.



The International Cospas-Sarsat System will cease satellite processing of 121.5/243 MHz beacons from 1 February 2009. From that date only 406 MHz beacons will be detected by the Cospas-Sarsat satellite system. This affects all maritime beacons (EPIRBs), all aviation beacons (ELTs) and all personal beacons (PLBs).

1.2.2 DISTRESS LOCATION DETERMINATION

See figure 7.1.b

The location of the distress signal is determined by taking measurements of the doppler shift of the EPIRB frequency when the satellite first approach and then pass the EPIRB.

The actual frequency is heard at the time of closest approach (TCA). Knowing the position of the satellite and using the received doppler signal information, it is possible to determine the location of the Tron 40GPS MkII from the satellite at the TCA. At the LUT, actually two positions are calculated. One is the actual position (A) and the other is the mirror image (B) position. A second satellite pass confirms the correct location (A). With the 406 system the real solution can be determined on the first pass with a reliability of nearly 90% and down to an accuracy of less than 5 km (3.1 miles).

1.2.2.1 GPS ADVANTAGE

Tron 40GPS MkII has been designed to operate with the Cospas-Sarsat system and will enhance further the lifesaving capabilities of conventional beacons. The integrated 12 channel GPS module accept continuous positional information from the standard GPS system using 27 satellites providing an accuracy of approximately 100m. Upon activation of the Tron 40GPS MkII in an emergency situation, the positional information is incorporated into the distress message transmitted to the LUT. The main advantage with integrated GPS in Tron 40GPS MkII is the rapid response and positional accuracy, providing vital information during a rescue operation practically eliminating valuable time spent searching for the distressed. Whenever a distress message transmitted by Tron 40GPS MkII is detected by polar orbit satellite (LEOSAR) the delayed alert remains the same as for non-GPS integrated EPIRBs (max. 90 minutes), but the position accuracy is improved.

1.2.3 EPIRB REGISTRATION

Normally the MCC will contact the vessel or the contact person registered in a shipping register and/or an EPIRB register (Ships owner, family member etc.) before alerting the RCC. This is to determine if the alarm from the EPIRB for some reason is a false alarm, and an expensive rescue operation can be avoided. Because of this it is important that the ships data is correct in the shipping register or in the EPIRB database.

Tron 40GPS MkII purchased in some countries will have a registration form attached to it, it is important that this registration form is completed by the owner and returned to the place the EPIRB was purchased or to the address specified on the registration form.

Other countries use the already available shipping register to obtain the necessary information for a vessel in distress, in these countries the ship is already registered and no registration form is necessary, however it is vital that the coding of



the Tron 40GPS MkII is kept up to date with data on the ship (nationality, call sign, etc.), to minimize the time from an alarm to the start of the search and rescue operation. Reprogramming the Tron 40GPS MkII can be done at authorized Jotron AS agents in more than 180 different places throughout the world.

If you are a resident of the United States, you must register this beacon with the National Oceanic and Atmospheric Administration (NOAA) using the registration card included with the unit. Fill out the form and send it to: SARSAT Beacon Registry, NOAA-SARSAT, E/SP3, FB4, Room 3320, 5200 Auth Road, Suitland, MD 20746-4304

Vessel owners shall advise NOAA in writing upon change of vessel or EPIRB ownership. Transfer of EPIRB to another vessel, or any other change in registration information, NOAA will provide registrants with proof of registration and change of registration postcards.



2 TECHNICAL SPECIFICATIONS

2.1 GENERAL

| | |
|------------------------|---|
| Battery: | Lithium , SAFT LSH14L, 5 years service life. |
| Housing: | Polycarbonate w/ 10% glassfibre |
| Dimensions: | Height: 379 mm Max diameter: 180 mm, Weight app.: 2.0 kg |
| Materials: | Polycarbonate. |
| Compass safe distance: | 1.5 m |
| Temperature range: | -20oC to + 55oC |
| Operating life: | Minimum 48 hours at -20oC |

2.2 COSPAS/SARSAT TRANSMITTER

| | |
|----------------|---|
| Frequency: | 406.037 MHz - + 2 ppm |
| Output power: | 5W +- 2 dB |
| Protocols: | Tron 40GPS MkII: Maritime, Serialized, Radio Call sign |
| Modulation: | Phase modulation 1.1 +- 0.1 rad |
| Data encoding: | Bi Phase L |
| Stability: | Short term <- 10-9 Medium term <- 10-9 Residual noise <- 3x10-9 Bit rate: 400 b/s Antenna: Built in, omnidirectional. |

2.3 NAVIGATION DEVICE

| | |
|------------|------------------------------------|
| Type: | iTrax03-S, 12 Channel GPS Receiver |
| Frequency: | L1 frequency band |
| Antenna: | Patch type |



2.4 HOMING TRANSMITTER

| | |
|---------------|--|
| Frequency: | 121.500 MHz |
| Output power: | Up to 100 mW, depending on model. |
| Modulation: | A9, AM sweep tone between 300Hz and 1600Hz. Sweep range: 700 Hz. Sweep rate: 2.5 Hz. |
| Stability: | 10 ppm over temperature range. |
| Antenna: | Built in, omni directional. |

2.5 BRACKETS

See figure 7.8

| | |
|--------------------|--|
| Materials: | Luran S/ ABS |
| Dimensions: | Depth w/Beacon installed: 200 mm Weight: app 1.6 kg |
| Release mechanism: | Hydrostatic release unit Hammar H20 with Jotron special bolt |



3 FUNCTIONAL DESCRIPTION

3.1 GENERAL

The Tron 40GPS MkII consists of upper and lower house mounted together with an equator ring with gasket and locking pin.

Tron 40GPS MkII may be split into the following main parts:

1. EPIRB module with antenna
2. Battery module
3. Equator ring with gasket.

3.1.1 EPIRB MODULE WITH ANTENNA

The EPIRB module consists of two printed circuit boards, which are mounted in the upper housing:

1. The main board with main switch.
2. Antenna board (121.5 / 406 MHz) with indicator / flash LED.

For automatic activation of the EPIRB module, put the Tron 40GPS MkII in the upright position into the water, and the transmission starts when the seawater completes the circuit between the two external electrodes (sea water contacts).

When the Tron 40GPS MkII is mounted in the automatic release bracket mechanism, there is a safety switch in the EPIRB module, a reed contact activated by a magnet in the bracket, which disables the seawater contacts.

If the 40GPS MkII mounted in the automatic release bracket is submerged in water, the hydrostatic release mechanism will release the Tron 40GPS MkII at a depth of 2-4 meters. The transmission will start when the circuit between the seawater contacts is closed and the Tron 40GPS MkII is out of the bracket.

The EPIRB module may be manually activated with the main switch, and is then independent of seawater contacts. The EPIRB module will also operate while placed in the bracket when manually activated.

The Tron 40GPS MkII may easily be released from the mounting bracket manually. The main switch is also located on the main board.

The housing is made of polycarbonate.



3.1.2 BATTERY MODULE

The Battery module supplies the EPIRB module with 7.2 VDC power to keep the EPIRB transmitters active for 48 hours when activated, and for test sequences. The battery module consists of four SAFT LSH14L Lithium-Thionyl chloride (Li-SOCL₂) batteries connected in series and is attached inside the lower house. The housing is made of polycarbonate. In the lower part of the housing there is one reed contact, which is activated by a magnet in the release mechanism. This is the safety switch, which prevents the seawater contacts from activating the beacon while placed in the mounting bracket. There is a brass weight, which gives stability while floating.

The seawater contacts are also mounted in the battery module, and are connected to the electronic unit via the battery connector.

The batteries are mounted in a plastic battery holder.

3.1.3 EQUATOR RING WITH GASKET

The two parts of the housing are held together by the equator ring, and is locked with a U-shaped bolt of stainless steel and a split pin. Between the two halves of the housing there is a gasket made of neoprene.

4 INSTALLATION

4.1 BRACKETS

Five different brackets are currently available for the Tron 40GPS MkII. MB5 and MB4 are the manual brackets. FB5, FB4 and FBH4 are the automatic brackets. The manual brackets come without the hydrostatic release mechanism and are used to store the beacon inside the wheelhouse or other protected places. The automatic brackets are mounted in a free space outside where the beacon can be released automatically. MB5 and FB5 are delivered with protective cover.



4.1.1 FLOAT FREE BRACKET FB5 AND FB4

WARNING:

DO NOT INSTALL THE EPIRB NEAR STRONG MAGNETIC FIELDS THAT COULD ACTIVATE THE BEACON. When the Tron 40GPS MkII is mounted in the float-free bracket, FB5 or FB4, it will operate as an automatic float free unit. Since the release of the EPIRB will be automatic it is important to mount the bracket in a place where there are no obstacles that can endanger the automatic release of the EPIRB. The location where the bracket is mounted should be as high as possible on the vessel, and well protected from environmental conditions such as direct sea-spray, chemicals, oil, exhaust and vibrations. The location must also be easily accessible for testing and maintenance.

4.1.2 FLOAT FREE BRACKET FBH4

See figure 7.8 for installation.

The float free bracket FBH4 must be connected to the fixed installation (230V AC, 10A) through the thermostat connection box according to the connection diagram below.

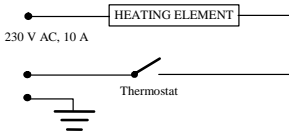

Figure 4.1.2 Connection diagram FBH4

4.1.3 MANUAL BRACKET MB5 AND MB4

When the Tron 40GPS MkII is mounted in the MB5 or MB4 bracket, it will operate as a manual unit. This bracket is the same as the FB5 and FB4 bracket but does not have the hydrostatic release mechanism. This bracket is typically used to store the EPIRB inside the wheelhouse or other protected areas of the ship. When the Tron 40GPS MkII is mounted in the MB5 or MB4 bracket, it must be manually removed before any operation can take place, therefore the bracket should be mounted in an easily accessible place where it can be removed in a hurry in case of an emergency.



4.1.4 MOUNTING THE FB5/MB5/FB4/FBH4/MB4 BRACKETS

See figure 7.8

The bracket is mounted with 4x6mm bolts according to the drawing. Use the bolts supplied with the bracket. The bracket could be mounted in either a vertical or horizontal position, whichever is the best regarding maintenance and operation.

5 OPERATION INSTRUCTIONS

The Tron 40GPS MkII is designed to be operated either manually or automatically. The EPIRB is always armed, that is the EPIRB will automatically start to transmit when the EPIRB is out of the bracket and deployed into water. In the lower part of the EPIRB there is an automatic safety switch. This switch prevents the seawater contacts from operating the EPIRB (caused by ice, sea-spray etc.) as long as the EPIRB is placed in its bracket. See chapter 6.5 Error codes.

5.1 MANUAL OPERATION

See figure 1.1

WARNING! USE ONLY DURING SITUATIONS OF GRAVE AND IMMINENT DANGER

For operation of the beacon in the bracket please follow instructions 1 to 3.

To manually remove the beacon from the bracket, pull out the locking pin on the clamp and open the retaining rod that holds the beacon.

Tie the beacon lanyard to you or to the survival craft and then follow instructions 1 to 6, or put beacon in the water to activate it.

It is not recommended to operate the beacon inside a life raft or under a cover or canopy. Do NOT tie the lanyard to the ship in distress, as this will prevent the unit to functioning if the ship sinks.

1. Break the seal and pull the locking pin holding the main activator switch.
2. Push slider to move switch to ON position.
3. The switch is spring-loaded and will automatically go to the ON position.
4. The strobe light, located at the top of the EPIRB, will start flashing indicating that the EPIRB is operating.
5. If possible keep the EPIRB in an open area, away from any metal objects (ship construction etc.) that may limit the satellite coverage.
6. Transmission can be stopped by turning the switch to READY position.



5.2 AUTOMATIC OPERATION (FB4/FBH/FB5)

1. The Tron 40GPS MkII will automatically release from the bracket, float to the surface and start to transmit when the EPIRB, in its bracket is deployed into water at a depth of app. 2-4 meters (6 - 13 feet).
2. Alternatively the EPIRB can be manually released from the bracket and put into the water.
3. Transmission will continue until the EPIRB is lifted out of the water, and dried off.
The transmission can also be stopped by placing the EPIRB in the bracket.

5.3 MANUAL TEST OF THE EPIRB

WARNING! The self-test should be performed only within the first 5 minutes of any hour. See figure 7.4

To perform the self-test, the EPIRB has to be removed from the bracket.

FB4 bracket: Remove EPIRB from the bracket by pulling out the locking pin on the clamp and open the retaining rod that holds the beacon.

FB5 bracket: Release FB5 to top cover by removing the locking split pin and special washer.

WARNING

The EPIRB can drop out of the FB5 bracket when releasing top cover

1. Press the spring-loaded switch on top of the EPIRB to the TEST position.
Keep hands and other objects away from the upper part of the EPIRB (away from the antenna).
2. A successful test will consist of one strobe flash after app. 15 seconds.
3. If the EPIRB fails to end up with a continuous light, this indicates a fault in the EPIRB. See chapter 6.5 EPIRB module error message.
4. Release the switch and put the EPIRB back into the bracket. What the self-test actually does is first to wait app. 15 seconds to allow the reference oscillator inside the EPIRB to warm up. Then a short burst is transmitted by the 121,5 MHz transmitter, while the output level of the transmitter is checked. Finally, a test signal is transmitted by the 406 transmitter. During this test signal the battery voltage, output power and frequency is checked.

While testing the 406 MHz transmitter a test message is transmitted, this test message is coded with a special synchronisation code and will not be detected by the COSPAS/SARSAT satellites. The purpose of this test message is to control the actual coding of the EPIRB. This can be done with the Jotron AS test unit Tron DEC/UniDEC or an other EPIRB tester.



6 MAINTENANCE AND TROUBLESHOOTING

6.1 EPIRB MODULE / BATTERY MODULE

The EPIRB shall be tested and approved as required by SOLAS regulation IV/15.9.2 of SOLAS 1974 as amended with, in accordance with MSC/Circ.1039 guidelines for shore-based maintenance of Satellite EPIRBs within 5 years if: Passenger ships (>12 passengers) and cargo ships (>300GT) engaged in international voyages, shall perform Shore-Based Maintenance (SMB) as follows:

- Latest by the date of the EPIRB label with this text, or the battery label, whichever is first.
- When this EPIRB becomes due for SBM in accordance with national requirements.

6.1.1 CHANGE OF BATTERY

If the Tron 40GPS MkII is the main EPIRB on board the ship, the rules of SBM apply, and the battery must be changed at an SBM authorized workshop.

If the Tron 40GPS MkII is the second EPIRB on board the ship, authorized personnel can change the battery on board.

6.1.2 REPLACING THE BATTERY MODULE

See figure 7.7

To change the battery, the lower Tron 40GPS MkII assembly is replaced with a new one. The battery module consists of the complete lower half of the Tron 40GPS MkII and is to be replaced every 5 years. The marking on the battery module shows the expiry date. A new battery comes complete and is easily replaced by opening the equator ring between the top and bottom of the EPIRB. The battery must be replaced if the EPIRB is activated for any purpose other than test.

Replacing the battery module should be done by a Jotron AS authorised SBM provider. Your closest Jootron AS agent with TronSTAT facilities has been specially trained to perform the necessary operation and is also able to do an extended test of the EPIRB, ensuring that the EPIRB operates within the specifications.

1. Remove the EPIRB from its bracket .
2. Remove the equator ring by pressing it out from the housing.
3. Separate the two halves of the EPIRB housing.
4. Unplug the 6-pin connector that comes from the lower EPIRB housing.
5. Ensure that the new battery module is marked with p/n 83056 and has a new expiration date, approximately 5 years from purchase.



6. Fit a new gasket on top of the battery module and reconnect the 6-pin connector, be sure that the connector is fitted properly. A noticeable «click» should be heard when the connector is in place.
7. Please make sure that the enclosed silica-gel bag is fastened inside the emergency product, with the supplied strips into/between holes in the black cover.
IMPORTANT: Cut the strips p/n 96898 after mounting of silica gel to avoid the strips to come between rubber gasket and top housing.
8. Please also fit the enclosed anti corrosion adhesive tape to the inside of the battery before assembling the unit.
9. Orientate the two halves of the EPIRB the following way:
An orientation tab is fitted on both halves of the EPIRB, these tabs must be placed carefully on top of each other.
10. Make sure that the gasket is properly in place, and replace the equator ring using a special tool to tighten it together.
11. Replace the U-shaped bolt and a new split pin to secure the bolt in the equator ring.
12. Remount EPIRB in its bracket.

6.1.3 BATTERY DISPOSAL

Dispose in accordance with applicable regulations, which vary from country to country. (In most countries, the thrashing of used batteries is forbidden and the end-users are invited to dispose of them properly, eventually through non-profit organizations, mandated by local governments or organized on a voluntary basis by professionals). Lithium batteries should have their terminals insulated prior to disposal.

6.1.4 INCINERATION

Incineration should never be performed by battery users but eventually by trained professionals in authorized facilities with proper gas and fumes treatment.



6.1.5 LAND FILLING

Leachability regulations (mg/l)

| Component | Leachability | EC limit | EPA | Other* |
|-----------|--------------|----------|-----|--------|
| Iron | 100 | | | 5 |
| Nickel | 100 | 500 | 2 | 0,5 |

* Applicable to France

6.1.6 RECYCLING

Send to authorized recycling facilities, eventually through a licensed waste carrier.

6.2 HYDROSTATIC RELEASE REPLACEMENT

For details see chapter 6.2.1 and 6.2.2.

6.2.1 REPLACING THE RELEASE MECHANISM IN FB4/FBH4 BRACKET

See figure 1.1

The hydrostatic unit fitted on the float free bracket [FB4/FBH4] must be replaced every 2 years. Marking the expiry date on the hydrostatic unit.

The hydrostatic comes complete with a new bolt and accessories.

1. Remove the EPIRB from its bracket by pulling out the locking pin on the clamp and open the retaining rod that holds the beacon.
2. Unscrew the plastic bolt (1) by screwing it counter clockwise and remove the hydrostatic release mechanism (2).
3. Check expiration date on the new hydrostatic release mechanism. The date should be approximately 2 years from the date of purchase.
4. Mount the new hydrostatic release mechanism. The unit is fixed to the bracket with a plastic bolt containing washer, rubber seal, washer, O-ring.
5. Secure the plastic bolt by hand force only!



6.2.2 REPLACING THE RELEASE MECHANISM IN FB5 BRACKET

See figure 7.6

1. Release FB5 top cover by removing the locking split pin and special washer (a).
WARNING! The EPIRB can drop out of the FB5 bracket when releasing the top cover.
2. Press down the spring-loaded bracket plate and remove the hydrostatic unit by sliding it out of its locking slot (b).
3. Check the expiry date of the new hydrostatic release mechanism (c). The date should be approximately two years from the date of purchase.
4. Install a new hydrostatic unit by pressing down the spring loaded bracket plate and sliding the unit into its locking slot (b).
5. Replace the EPIRB and the FB5 top cover.
Be sure that the top cover is locked at the bottom end and that the top end are fixed at hydrostatic release mechanism rod.
Replace the special washer and the locking split pin (a).

6.3 TRON 40GPS MKII SELF TEST

WARNING! The self-test should be performed only within the first 5 minutes of any hour. See figure 7.4

- Remove the beacon from the bracket.

FB4 bracket: Remove EPIRB from the bracket by pulling out the locking pin on the clamp and open the retaining rod that holds the beacon.

FB5 bracket: Release FB5 to top cover by removing the locking split and special washer.

WARNING! The EPIRB can drop out of the FB5 bracket when releasing top cover.

- Press the spring-loaded main switch of the EPIRB to the TEST position. Keep hands and other objects away from the upper part of the EPIRB (away from the antenna).
- A successful test will consist of a series of blinks on the LED test indicator, followed by a continuous light and a strobe flash after app. 15 seconds.
- If the EPIRB fails to end up with a continuous light, this indicates a fault in the EPIRB.
- Release the switch and put the EPIRB back into the bracket.



6.4 MAINTENANCE OF EPIRB

Every Month: Perform EPIRB self-test.

What the self-test actually does is to send out a short test signal on 121,5 and 406,037MHz, testing the output of the transmitter. While transmitting the test signal, the battery voltage, output power and phase lock is tested. During the test of the 406MHz transmitter a test message is transmitted, this test message is coded with a special synchronization code and will not be recognized as real alert by the COSPAS/SARSAT satellites. Carry out visual inspection for defects on both the Tron 40GPS MkII and Bracket. The Tron 40GPS MkII should be easily removed and replaced in the Bracket. Make sure that the Tron 40GPS MkII and Bracket is not painted or otherwise covered with chemicals, oil, etc. Check the expiry date of the EPIRB Battery and the Hydrostatic Release Mechanism. Check the presence of a firmly attached lanyard in good condition and that it is neatly stowed and is not tied to the vessel or the mounting bracket. If the Tron 40GPS MkII is the main EPIRB on board, these rules must be followed:

Every 12th month:

If the Tron 40GPS MkII is the main EPIRB on board and the ship falls under the SOLAS regulations of SBM, these rules must be followed: Perform extended annual test according to IMO's MSC/Circ.1040 (Annual testing of 406 MHz satellite EPIRBs) as required by SOLAS IV/15.9. This test can be carried out by one of Jotron AS authorized representatives or any other service provider in possession of a Tron UNIDEC, Tron DEC or any other Cospas/Sarsat EPIRB tester/decoder.

Every 2nd Year:

Hydrostatic Release Mechanism including Plastic Bolt on the Float Free Brackets must be replaced. (Check expiry date on label).

Every 5th Year:

See chapter 6.1

6.5 EPIRB ERROR MESSAGES

If the self-test detects a fault in the EPIRB module one or more of the following indications are shown:

| Number of flashes: | Fault indication: |
|--------------------|--|
| 1 | NON |
| 2 | Low power on 406 MHz transmitter |
| 3 | Low battery voltage |
| 4 | Low power on 121.5 MHz transmitter |
| 5 | PLL on 406 MHz transmitter out of lock |
| 6 | PLL on 121.5 MHz transmitter out of lock |
| 7 | EPIRB module not programmed or programming not complete. |

7 FIGURES

7.1 SIGNAL DETECTION

See chapter 1.2.1 and 1.2.2

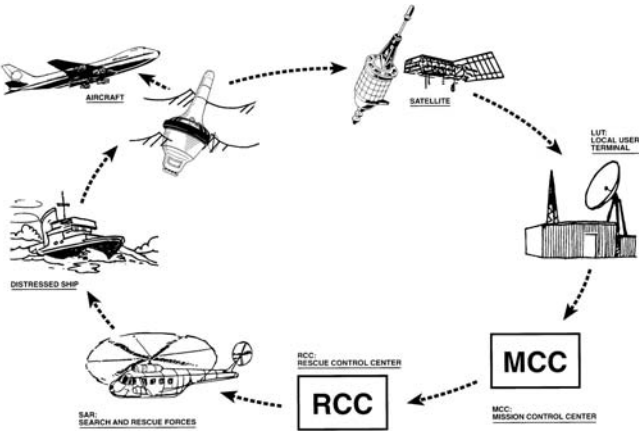

Figure 7.1.a

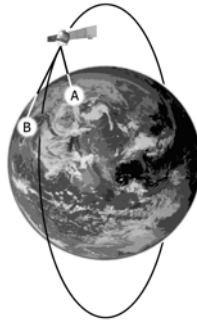

Figure 7.1.b

7.2 MANUAL OPERATION

See chapter 5.1

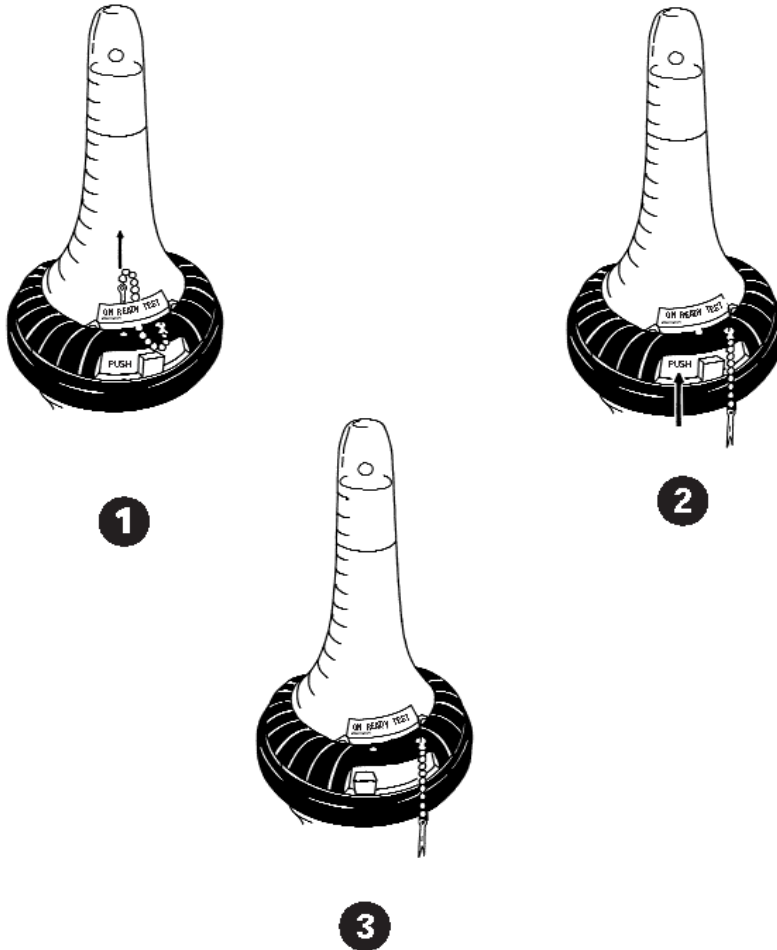

Figure 1.1

7.3 AUTOMATIC OPERATION

See chapter 5



Figure 7.3

7.4 SELF TEST

See chapter 5.3 and 6.3

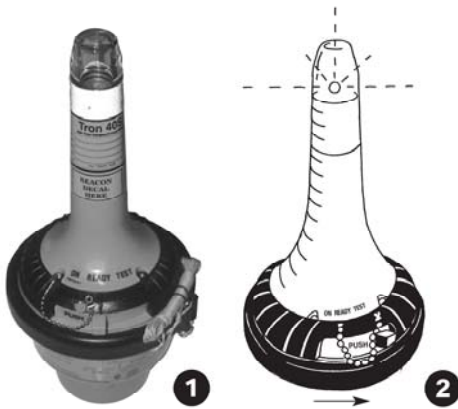

Figure 7.4

7.5 REPLACING THE RELEASE MECHANISM IN FB4/FBH4 BRACKET

See chapter 6.2.1

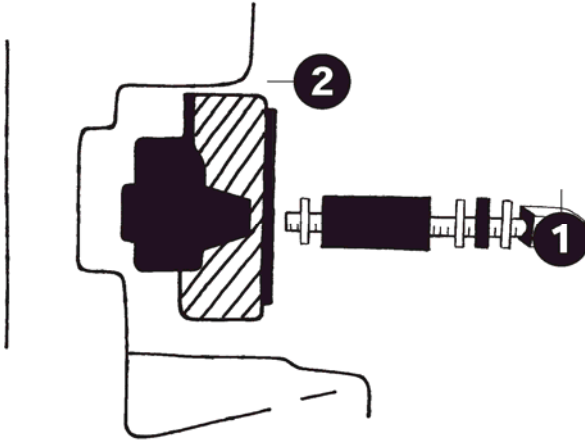

Figure 1.1

7.6 REPLACING THE RELEASE MECHANISM IN FB5 BRACKET

See chapter 6.2.2



Figure 7.6.a, b and c

7.7 REPLACING THE BATTERY MODULE

See chapter 6.1.2

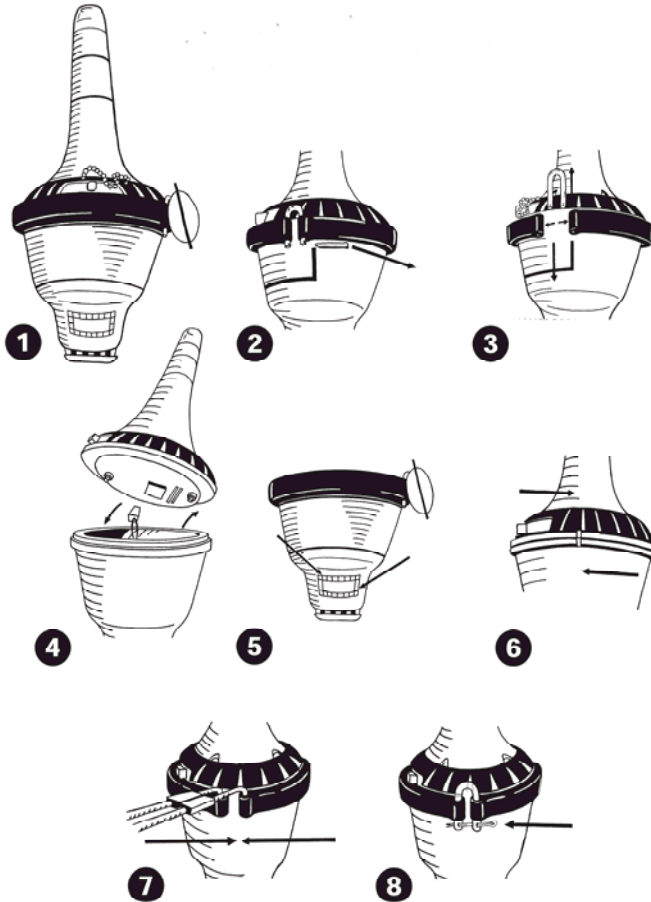

Figure 7.7a

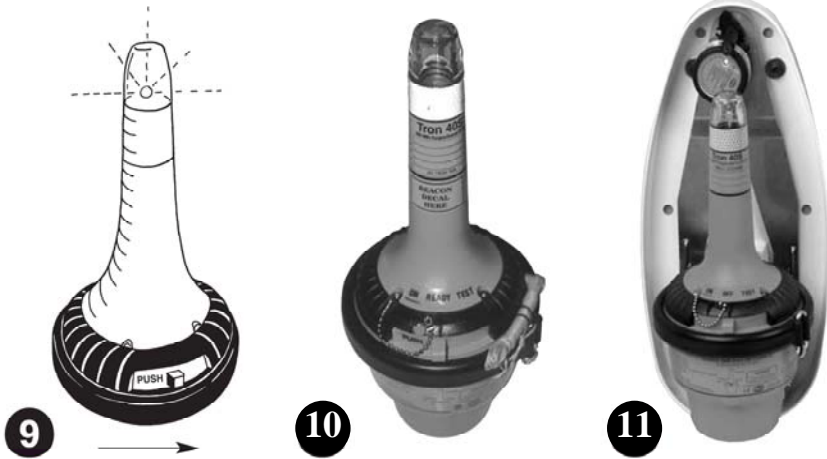

Figure 7.7.b

7.8 MOUNTING OF BRACKETS

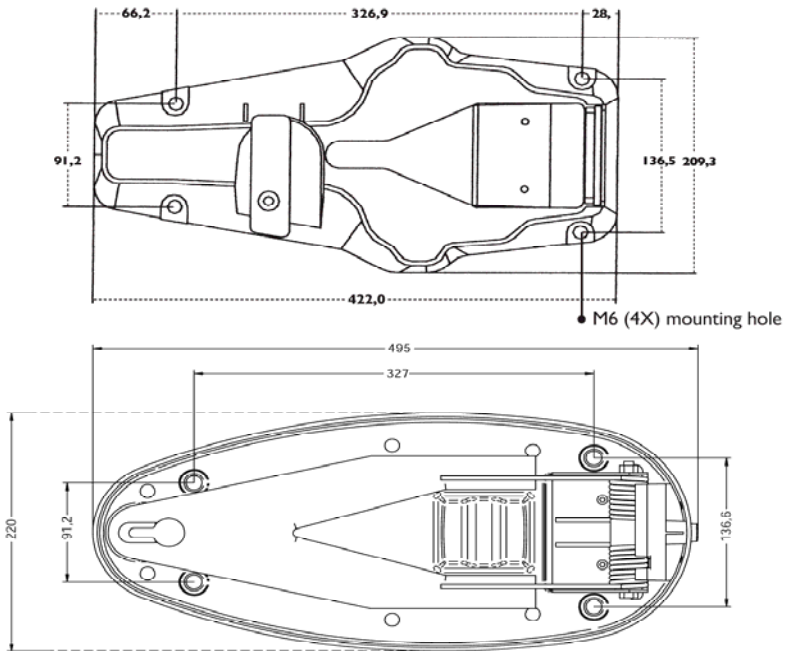

Figure 7.8



8 SERVICE AGENTS

Please look at www.jotron.com for Marine Service Agents.

Jotron Group subsidiary companies:

Jotron UK Ltd.
Crosland Park, Off Crowhall Road
Cramlington
Northumberland NE23 1LA
United Kingdom

Tel +44 1670 712000
Fax +44 1670 590265
E-mail: sales@jotron.co.uk

Jotron Asia Pte. Ltd.
Changi Logistics Center
19 Loyang Way #04-26
Singapore 508724

Tel +65 65426350
Fax +65 65429415
E-mail: sales@jotron-asia.com

Jotron USA, Inc.
10645 Richmond Avenue, Suite 140
Houston, TX 77042
USA

Tel +1 713 268 1061
Fax +1 713 268 1062
E-mail: contact.us@jotron-usa.com

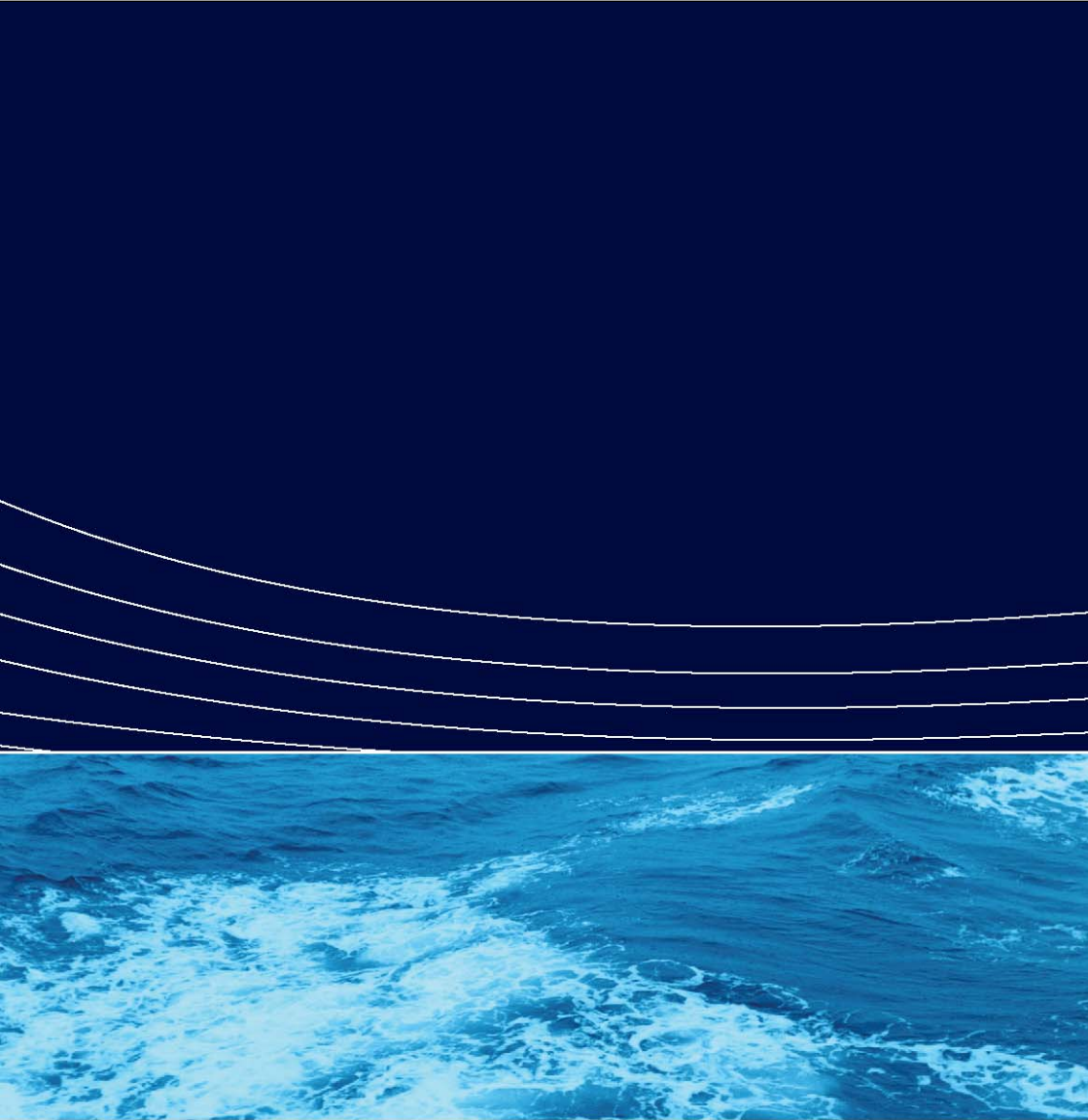

Jotron AS

P.O. Box 54, NO-3280 Tjodalyng, Norway
Tel: +47 33 13 97 00 | Fax: +47 33 12 67 80

www.jotron.com