



Tron AIS TR-8000

AIS Class A transponder





EC Declaration of Conformity, available at www.jotron.com

Table of Contents

1 Revision History	1-4
2 SPECIFICATIONS	2-5
2.1 Transponder unit	2-5
2.1.1 Integrated GPS	2-5
2.1.2 TDMA Transmitter	2-6
2.1.3 TDMA Receivers	2-6
2.1.4 DSC Receiver	2-7
2.2 Display unit	2-8
2.2.1 LCD Display with Touch	2-8
2.3 Transmission intervals	2-9
2.4 Interfaces	2-10
2.5 Transmission Intervals	2-10
3 DATA TRANSMISSION	3-11
3.1 Data transmission	3-11
3.1.1 RS422 interface	3-11
3.1.2 RS232 interface	3-12
4 DESCRIPTION OF SENTENCE FORMAT	4-14
4.1 Input	4-15
4.1.1 ABM - Addressed Binary and safety related Message	4-15
4.1.2 ACA - AIS Regional Channel Assignment Message	4-15
4.1.3 ACK - Acknowledge alarm	4-15
4.1.4 AIR - AIS Interrogation Request	4-16
4.1.5 AIQ - Query Sentence	4-16
4.1.6 BBM - Broadcast Binary Message	4-16
4.1.7 DTM Datum reference	4-17
4.1.8 EPV - Command or report equipment property value	4-17
4.1.9 GBS - GNSS satellite fault detection	4-19
4.1.10 GGA - Global positioning system (GPS) fix data	4-19
4.1.11 GLL - Geographic position - latitude/longitude	4-20
4.1.12 GNS - GNSS fix data	4-20
4.1.13 HBT Heart Beat	4-20
4.1.14 HDT - Heading true	4-21
4.1.15 LRF - Long Range Function	4-21
4.1.16 LRI - Long-Range Interrogation	4-21
4.1.17 OSD Own ship data	4-22
4.1.18 RMC Recommended minimum specific GNSS data	4-22
4.1.19 ROT - Rate of turn	4-23
4.1.20 SPW - Security password sentence	4-23
4.1.21 SSD - Station static data	4-23
4.1.22 VBW - Dual ground/water speed	4-24
4.1.23 VSD - Voyage Static Data	4-24
4.1.24 VTG - Course over ground and ground speed	4-24
4.1.25 ZDA - Time and date	4-25



4.2	<i>Output</i>	4-25
4.2.1	ABK - Addressed and binary broadcast acknowledgement	4-25
4.2.2	ACA - See "Input "	4-25
4.2.3	ALR - Set alarm state.....	4-25
4.2.4	EPV - See "Input "	4-26
4.2.5	HBT - See "Input "	4-26
4.2.6	LRF - See "Input "	4-26
4.2.7	LR1 - Long-range Reply with destination for function request "A"	4-26
4.2.8	LR2 - Long-range Reply for function requests "B, C, E, and F"	4-26
4.2.9	LR3 - Long-range Reply for function requests "I, O, P, U and W"	4-26
4.2.10	NAK - Negative acknowledgement	4-27
4.2.11	TRL - AIS transmitter non functioning log	4-27
4.2.12	TXT - Text transmission	4-28
4.2.13	VDM - VHF Data-link Message	4-28
4.2.14	VDO - VHF Data-link Own-vessel message.....	4-28
4.2.15	VER - Version.....	4-29
5	Abbreviations and Definitions.....	5-30



1 Revision History

AMENDMENT NO.	INCORP. BY	DATE	PAGE(S)	VERSION	REASON FOR CHANGE
1	FIT	12.4.2012	2-8	B	Added "IEC60945 Protected" to chapter 2.2
2					
3					
4					
5					
6					
7					
8					
9					
10					
11					
12					
13					
14					
15					
16					
17					
18					
19					
20					



2 SPECIFICATIONS

2.1 Transponder unit

Size:	274 x 204 x 67 mm
Size with bracket:	(319 x 204 x 76 mm)
Weight:	3.7 Kg
Color:	Black
Enclosure:	Aluminium
Supply voltage:	12-24 VDC +30% / -10%
Power consumption:	<15W average <50W burst
Operating temperature:	-25°C to +55°C
Storage temperature:	-40°C to +70°C
Environmental:	IP56 / IEC60945 exposed
Compass safe distance:	Standard Compass: 95cm Steering Compass: 65cm

2.1.1 Integrated GPS

Receiver type:	16 channel u-blox ANTARIS 4 positioning engine SBAS: WAAS, EGNOS, MSAS
Navigation update rate:	Up to 4 Hz
Accuracy ¹ :	Position: 2.5 m CEP SBAS: 2.0 m CEP
Acquisition ²	Cold Start: 36s Warm Start: 33s Hot Start: <3.5s Reacquisition: <1s
Sensitivity ³	Tracking: -158 dBm Acquisition: -148 dBm Cold Starts: -142dBm

¹ Depends on accuracy of correction data of DGPS or SBAS service

² Measured with good visibility and -125 dBm signal strength .

³ Demonstrated with a good active antenna. Sensitivity will reduce by 2 dB when using passive antennas.



2.1.2 TDMA Transmitter

Frequency Error	: < +/- 0.5 kHz under normal conditions (n.c.). < +/- 1.0 kHz under extreme conditions (e.c.).
Frequency Range	: 156.025-162.025MHz
Channel Switching Time	: < 25 ms.
Carrier Power, High power setting	: 12.5 W, 41dBm +/- 1.5dB (n.c.) +/- 3.0dB (e.c.)
Carrier Power, Low power setting	: 1 W, 30dBm +/- 1.5dB (n.c.) +/- 3.0dB (e.c.)
Data transmission bit rate	: 9600 bits/s +/- 50ppm.
Modulation Spectrum	: < -25 dBc @ $\Delta f_c < \pm 10$ kHz < -70 dBc @ ± 25 kHz $< \Delta f_c < \pm 62,5$ kHz
Modulation Accuracy test signal 2	: < +/- 175 (n.c.) < +/- 350 (e.c.)
Modulation Accuracy test signal 3	: < +/- 240 (n.c.) < +/- 480 (e.c.)
Maximum Transmission Time	: A transmission shall not exceed 5 slots (133ms).
Excessive Transmission Failure mode	: A transmission is shut down by hardware if transmission exceeds 300ms.
Spurious emissions	: < -36 dBm @ 9 kHz - 1 GHz < -30 dBm @ 1 GHz - 4GHz
Transmission output power versus time	: Power within mask shown in Fig.2 and timings given in Table 6 in ITU-R M.1371.4

2.1.3 TDMA Receivers

Sensitivity	: < 20% PER @ -107 dBm (n.c.) < 20% PER @ -101 dBm (e.c.)
Error behaviour at high input levels	: < 1% PER @ -77 dBm < 1% PER @ -7 dBm
Adjacent channel selectivity	: < 20% PER @ 70 dB (n.c.) < 20% PER @ 60 dB (e.c.)
Co-channel rejection	: < 20% PER @ 10 dB
Spurious response rejection	: < 20% PER @ 70 dB
Intermodulation response rejection	: < 20% PER @ 74 dB
Spurious emissions	: < -57 dBm (9 kHz to 1 GHz) < -47 dBm (1 GHz to 4 GHz)
Blocking	: < 20% PER @ 86 dB



2.1.4 DSC Receiver

Frequency Range	: Ch 70, 156.525 MHz
Sensitivity	: < 20% PER @ -107 dBm (n.c.) < 20% PER @ -101 dBm (e.c.)
Modulation	: PSK, 1200 Baud.
Error behaviour at high input levels	: < 1% PER @ -7 dBm
Co-Channel Rejection	: Between -10.0 db and 0 dB. See 61993-2, 5.4.3
Adjacent Channel Selectivity	: < 20% PER @ 70 dB (n.c.) < 20% PER @ 60 dB (e.c.)
Spurious Response Rejection	: < 20% PER @ 70 dB
Intermodulation response, rejection	: < 20% PER @ 65 dB
Blocking or desensitisation	: <20% PER @ 84 dB



2.2 Display unit:

Size:	192 x 144 x 52 mm
Size with bracket:	(210 x 150 x 84 mm)
Weight:	1.0 Kg
Color:	Black
Enclosure:	ABS
Supply voltage:	12-24 VDC +30% / -10%
Power consumption:	< 12W nominal < 20W max intensity
Operating temperature:	-25°C to +55°C
Storage temperature:	-30°C to +70°C
Environmental:	IP54 / IEC60945 protected
Compass safe distance:	Standard Compass: 30cm Steering Compass: 14cm

2.2.1 LCD Display with Touch

Display:	NEC NL8048BC19-02
Type:	WVGA, a-Si TFT LCD
Display Area:	152.4 x 91.44 mm
Diagonal size of display:	18 cm (7.0 inches)
Pixel:	800 x 480
Interface:	LVDS
Luminance:	400cd/m ²
Contrast	1000:1 (typ.)
Touch technology:	Resistive



2.3 Transmission intervals

The transmission intervals are normally as described in Table 1: Transmission intervals. Given certain conditions, as in assigned mode, or when other AIS stations are synchronizing to the unit, the transmission rate might be higher, but the absolute highest rate is once every 2 seconds.

Ship's dynamic conditions	Nominal reporting interval
Ship at anchor or moored and not moving faster than 3 knots	3 min
Ship at anchor or moored and moving faster than 3 knots	10 s
Ship 0-14 knots	10 s
Ship 0-14 knots and changing course	3.33 s
Ship 14-23 knots	6 s
Ship 14-23 knots and changing course	2 s
Ship > 23 knots	2 s
Ship > 23 knots and changing course	2 s

Table 1: Transmission intervals.



2.4 Interfaces

	Input sentences	Output sentences
Sensor 1, 2 and 3: (External GPS, Gyro and ROT/LOG)	DTM, GBS, GGA, GLL, GNS, HDT*, OSD, RMC, ROT, VBW, VTG, ZDA	
External Display, Aux Display/ Pilot Port	ABM, ACA, ACK, AIR, AIQ, BBM, EPV, HBT, SPW, SSD, VSD, LRF, LRI DTM, GBS, GGA, GLL, GNS, HDT*, OSD, RMC, ROT, VBW, VTG, ZDA,	ABK, ACA, ALR, EPV, HBT, NAK, TRL, TXT, VER, VDM, VDO, LR1, LR2, LR3, LRF,
Long Range Port	LRF, LRI	LR1, LR2, LR3, LRF

*) \$HCHDT will be rejected. \$HEHDT will be accepted.

All the above ports comply with IEC 61162-1 (Second edition, 2000-07) at 4800 baud and IEC 61162-2 (First edition, 1998-09) at 38400 baud

Alarm Output: Isolated digital switch.

2.5 Transmission Intervals

Message output:	Description:
VDM:	At RX of VDL message
VDO:	1 second
ALR:	30 seconds during alarm, 1 minute otherwise (empty message)
ABK, ALR, NAK, TXT:	At each event
LRF, LR1, LR2, LR3:	As response to LRI/LRF requests
ACA, TXT, VSD, SSD, TRL, VER:	At request via query command (AIQ)

3 DATA TRANSMISSION

3.1 Data transmission

Data is transmitted in serial asynchronous form in accordance with the standards referenced in 2.1 of IEC 61162-1/2. The first bit is a start bit and is followed by data bits, least-significant-bit first, as illustrated by figure below.

The following parameters are used:

- baud rate: 4 800 to 38 400
- data bits: 8 (D7 = 0),
- parity: none;
- stop bits: 1.

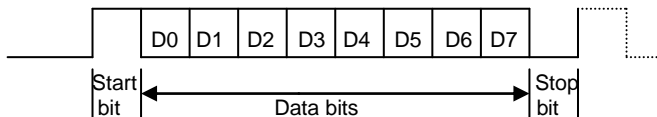

3.1.1 RS422 interface

There are 4 RS422 inputs and 3 RS422 I/O ports on the Transceiver unit.

Sensor 1-3 and DGNSS beacon are inputs.

External Display, Pilot Plug and Long Range are IO ports.

The External Display and the Pilot Plug have a fixed baud rate of 38400 because of the amount of data transferred. The rest of the RS422 ports have adjustable baud rates (4800/9600/19200/38600).

The Driver circuit ISO3080 is galvanically isolated. The connector on the Transponder is 5mm Double Deck Terminal Strips from WAGO (736-204). On the Display unit, the connector is a circular 12p female connector from Bulgin (PX0413/12S/PC).

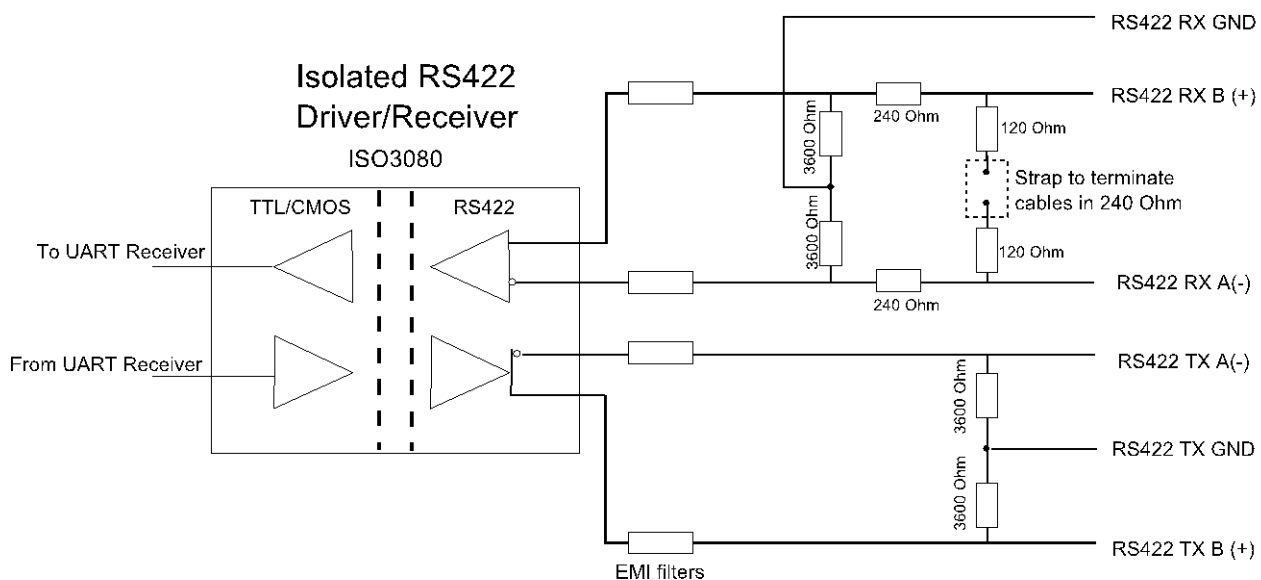

Figure 1: Simplified diagram of the RS422 interface



3.1.1.1 Electrical characteristics RS422 interface.

Parameter	Test Condition	MIN	TYP	MAX	UNIT
V_O Voltage at either bus I/O terminal	A,B	-15		15	V
V_{ID} Differential input voltage	A with respect to B	-15		15	V
R_L Differential input resistance	w/jumper		232		Ω
	Wo/jumper		7680		Ω
$V_{IT(+)}$ Positive going input threshold voltage	$I_O = -8mA$		-85	-10	mV
$V_{IT(-)}$ Negative going input threshold voltage	$I_O = 8mA$	-200	-115		mV
Isolation	60s		2500		Vrms
I_O Output current Receiver		-8		8	mA
Differential output voltage magnitude	$I_O = 0mA$, no load	3	4.3	5	V
	$R_L = 54\Omega$	1.5	2.3		V
	$R_L = 100\Omega$	2	2.3		V
I_O Output current Driver		-60		60	mA

3.1.2 RS232 interface

The functionality of the External Display can be setup by software to use the RS232 port as physical interface instead of the RS422 port which is default. The baud rate is fixed to 38400. The Interface is galvanically isolated by an ISO7221A Optocoupler. The connector on the Transponder is 5mm Double Deck Terminal Strips from WAGO (736-204).

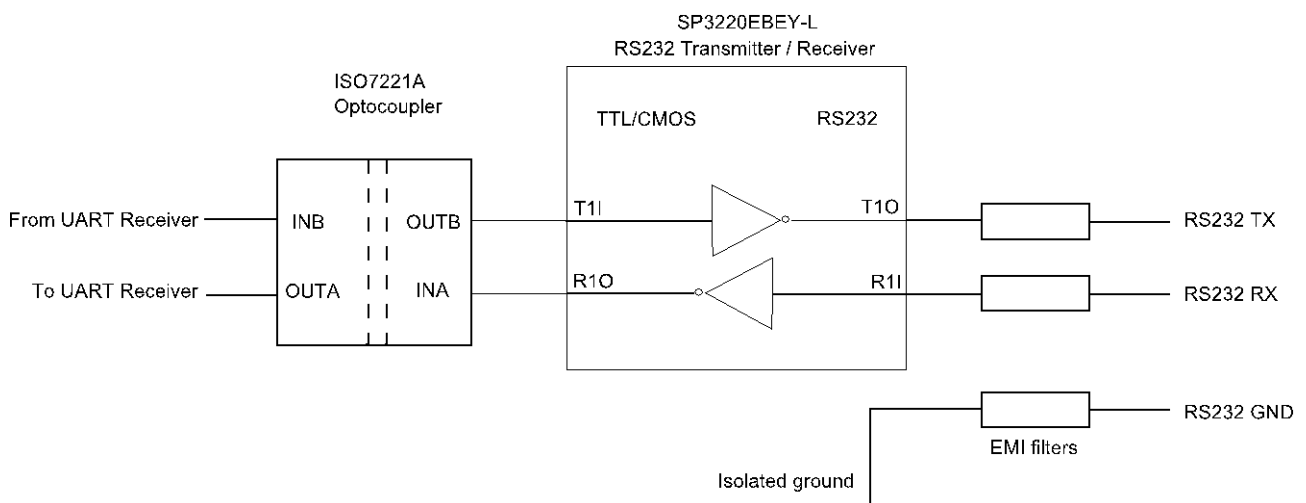

Figure 2: Simplified diagram of the RS232 interface



3.1.2.1 Electrical characteristics RS232

	Min	Typ	Max	Unit
Input Resistance	3	5	7	k Ω
Input Voltage Range	-15		15	V
Input Threshold LOW	0.8	1.5		V
Input Threshold HIGH		1.8	2.4	V
Output Resistance	300			Ω
Output Voltage Swing	± 5.0	± 5.4		V
Output Short-Circuit Current		± 32	± 60	mA

3.1.2.2 Display connection

The display is interfaced over Ethernet by LAN8187, enabling data from 10 to 100Mbit/s. The circuit is galvanically isolated by a transformer and isolated to ground by 2kV capacitors. The interface is compliant with IEEE 802.3-2005 standards. The connector is a circular RJ45 connector, Bulgin PX0833/E on the Transponder and PX0839/PC on the Display Unit. The default IP address of the Transponder is 10.0.0.10 and the default IP address of the Display Unit is 10.0.0.11.

3.1.2.3 Alarm relay

The Alarm relay is a mandatory normally open earth free relay contact, provided as an independent and simple method for triggering an external alarm. The alarm relay is active in case of power off and is capable of driving a 2A current. The relay is implemented as a FET-switch, using FDS3992 Dual N-Channel PowerTrench[®] MOSFET. . The connector on the Transponder is 5mm Double Deck Terminal Strips from WAGO (736-204).

	Min	Typ.	Max	Unit
Voltage			48	V
Current			2	A
Resistance		124		m Ω



4 DESCRIPTION OF SENTENCE FORMAT

The following provides a summary explanation of the approved sentence structure according to IEC 61162:

\$aacc, c---c*hh<CR><LF>

ASCII	HEX	Description
"\$"	24	Start of sentence: starting delimiter
aacc		Address field: alphanumeric characters identifying type of talker, and sentence formatter. The first two characters identify the talker. The last three are the sentence formatter mnemonic code identifying the data type and the string format of the successive fields. Mnemonics will be used as far as possible to facilitate read-outs by users.
","	2C	Field delimiter: starts each field except address and checksum fields. If it is followed by a null field, it is all that remains to indicate no data in a field.
c---c		Data sentence block: follows address field and is a series of data fields containing all of the data to be transmitted. Data field sequence is fixed and identified by the third and subsequent characters of the address field (the sentence formatter). Data fields may be of variable length and are preceded by delimiters ",".
"*"	2A	checksum delimiter: follows last data field of the sentence. It indicates that the following two alpha-numeric characters show the HEX value of the checksum.
hh		Checksum field: the absolute value calculated by exclusive-OR'ing the eight data bits (no start bits or stop bits) of each character in the sentence between, but excluding, "\$" and "*". The hexadecimal value of the most significant and least significant four bits of the result are converted to two ASCII characters (0-9, A-F) for transmission. The most significant character is transmitted first. The checksum field is required in all cases.
<CR><LF>	0D 0A	End of sentence: sentence terminating delimiter.



4.1 Input

4.1.1 ABM - Addressed Binary and safety related Message

Support for ITU-R M.1371 messages 6, 12, 25, 26, 70 and 71

Provides an external application with a means to exchange data using the AIS.

!--ABM,x,x,x,xxxxxxxx,x,x,x,s--s,x*hh<CR><LF>

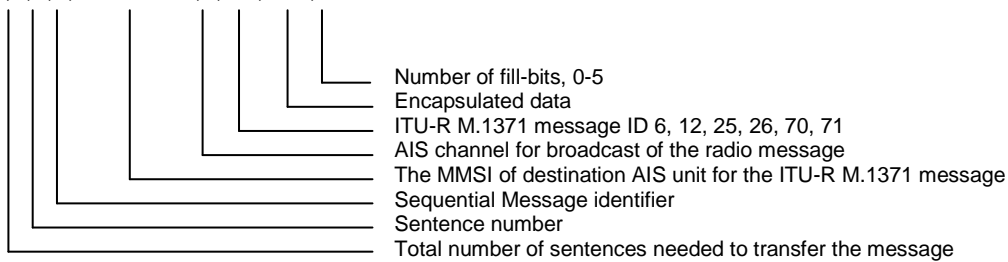

4.1.2 ACA - AIS Regional Channel Assignment Message

This sentence is used to both enter and obtain channel management information.

\$--ACA,x,IIII.II,a,yyyy.yy,a,IIII.II,a,yyyy.yy,a,x,xxxx,x,xxxx,x,x,x,a,x,hmmss.ss*hh<CR><LF>

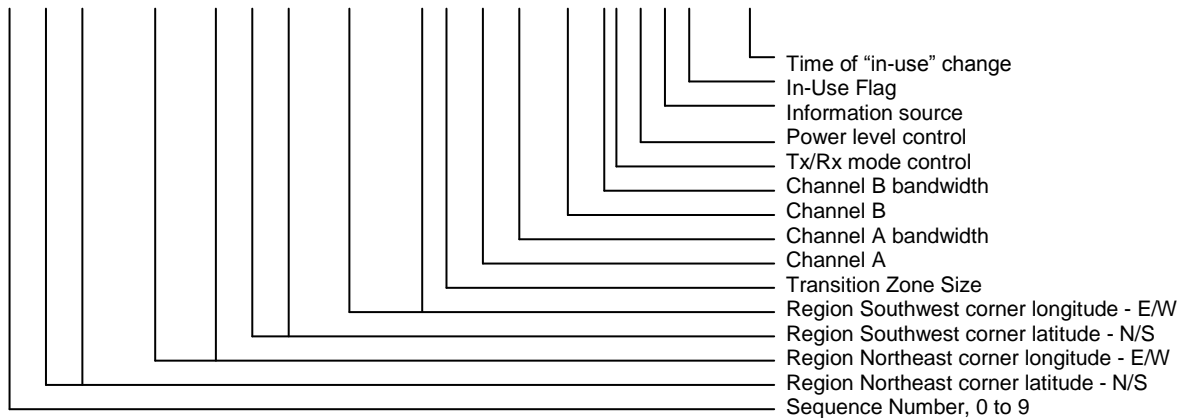

4.1.3 ACK - Acknowledge alarm

This sentence is used to acknowledge an alarm condition reported by a device.

\$--ACK,xxx,*hh<CR><LF>





4.1.4 AIR - AIS Interrogation Request

This sentence supports ITU-R M.1371 message 15. It provides an external application with the means to initiate a request for specific ITU-R M.1371 messages from distant mobile or base AIS stations.

`$--AIR,xxxxxxxx,x.x,x.x,x.x,xxxxxxxx,x.x,x*hh<CR><LF>`

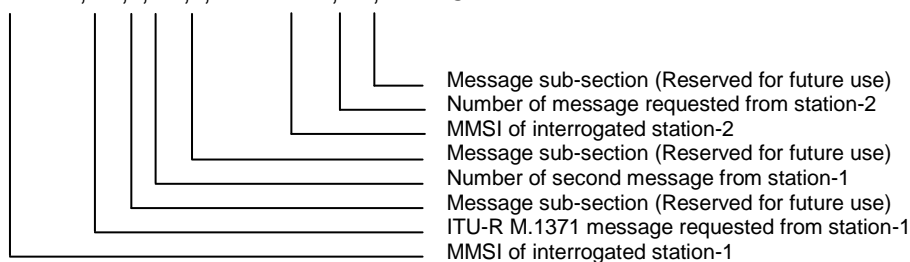

4.1.5 AIQ - Query Sentence

This sentence is used to query some of the other messages from the AIS. The queries which will be answered are: ACA, SSD, TRL, TXT, VER and VSD.

`$--AIQ,XXX.`



4.1.6 BBM - Broadcast Binary Message

Support for ITU-R M.1371 messages 8, 14, 25, 26, 70 and 71

It provides an external application with a means to broadcast data, as defined by the application only - not the AIS.

`!--BBM,x,x,x,x,x,x,s--s,x*hh<CR><LF>`

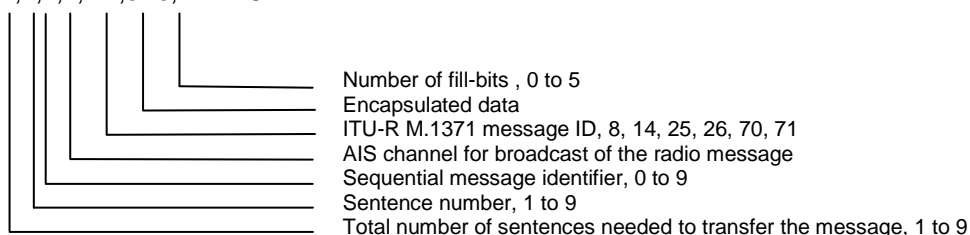



4.1.7 DTM Datum reference

Local geodetic datum and datum offsets from a reference datum

`$-DTM,W84,a,x.x,a,x.x,a,x.x,ccc*hh<CR><LF>`

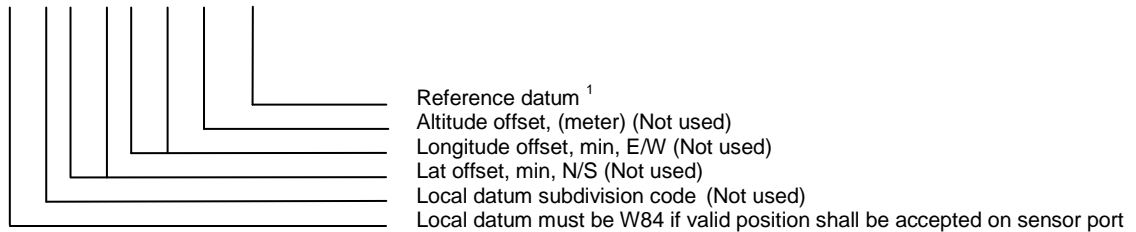

Note 1: WGS84 = W84
WGS72 = W72
SGS85 = S85
PE90 = P90
User defined =999 (only available for “Local datum”)
IHO datum code

Important: If a DTM sentence is received, it MUST contain “W84” as “Local Datum”, otherwise position information received in GGA, GLL, RMC or GNS on that sensor port will be rejected.

4.1.8 EPV – Command or report equipment property value

This sentence is used to set the properties of the AIS unit, the message is replied with the set value as an ack when the value is set.

`$-EPV,a,cc,c--c,x.x,c--c,*hh<CR><LF>`

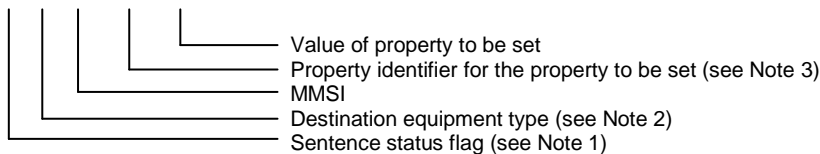

Note 1: Sentence status flag:
C = Command
R = Response
<Empty field> = request value

Note 2: Indicates which equipment type. Indicated by the Talker Id. Every Talker Id has defined a set of Property Identifier. Supported values are AI and JTR.

Note 3: The property identifier is a variable length integer field that identifies a parameter that can be set in accordance with the table below and is intended for commissioning settings.

Proprietary Property Identifiers (for equipment type “JTR”) will be provided to manufacturer of display system on request.

The following Property Identifiers in are permitted for the equipment type “AI”:



Property Identifier	Property Meaning	Value range
0-100	Reserved	
101	Sensor 1 baud	4800, 9600, 14400, 19200, 38400
102	Sensor 2 baud	4800, 9600, 14400, 19200, 38400
103	Sensor 3 baud	4800, 9600, 14400, 19200, 38400
104	Long Range baud	4800, 9600, 14400, 19200, 38400
105	DGNSS baud	4800, 9600, 14400, 19200, 38400
106	MMSI	000000000, 200000000 ... 799999999
107	IMO Number	0000000 ... 9999999
108	Long Range configuration	“A” = automatic “M” = manual
109	Long Range AIS channel 1	Valid channel according ITU-R M.1084-4
110	Long Range AIS channel 2	Valid channel according ITU-R M.1084-4
111	Change administrator password	New administrator password
112	Change user password	New user password
113	AIS-SART test mode	0 = normal mode 1 = display and output AIS-SART in test mode
All other values	Reserved	

Table 2 Standard Ais Property Identifier for Destination Equipment "A1"



4.1.9 GBS - GNSS satellite fault detection

This message is used to support receiver autonomous integrity monitoring (RAIM). Given that a GNSS receiver is tracking enough satellites to perform integrity checks of the positioning quality of the position solution; a message is needed to report the output of this process to other systems to advise the system user. With the RAIM in the GNSS receiver, the receiver can isolate faults to individual satellites and not use them in its position and velocity calculations.

Also, the GNSS receiver can still track the satellite and easily judge when it is back within tolerance.

This message shall be used for reporting this RAIM information. To perform this integrity function, the GPS receiver must have at least two observables in addition to the minimum required for navigation. Normally these observables take the form of additional redundant satellites.

\$--GBS, hhmmss.ss, x.x, x.x, x.x, xx, x.x, x.x, x.x,h,h*hh <CR><LF>

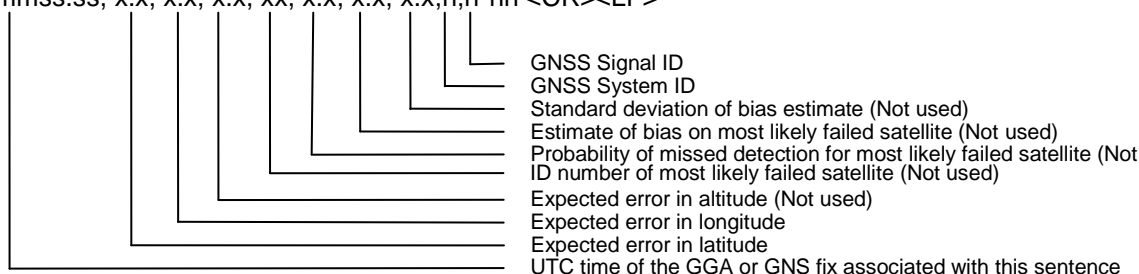

4.1.10 GGA - Global positioning system (GPS) fix data

Time, position and fix-related data for a GPS receiver.

\$--GGA, hhmmss.ss, llll.ll, a, yyyy.yy, a, x, xx, x.x, x.x, M, x.x, M, x.x, xxxx*hh<CR><LF>

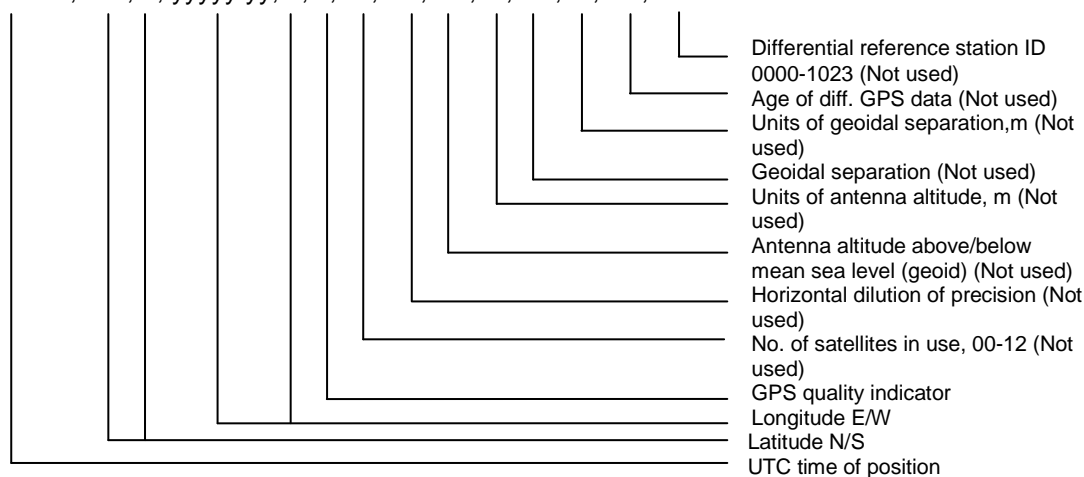



4.1.11 GLL - Geographic position - latitude/longitude

Latitude and longitude of vessel position, time of position fix and status.

\$-GLL, llll.ll, a, yyyy.yy, a, hhmmss.ss, A, a *hh<CR><LF>

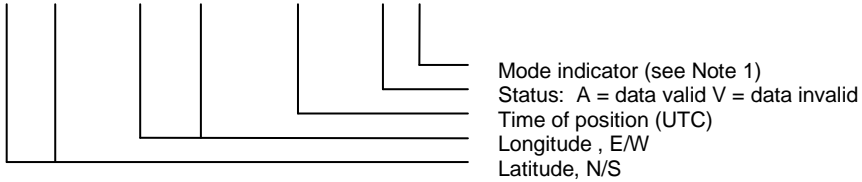

Note 1: Positioning system Mode indicator:

- A = Autonomous
- D = Differential
- E = Estimated (dead reckoning)
- M = Manual input
- S = Simulator
- N = Data not valid

4.1.12 GNS - GNSS fix data

Fix data for single or combined satellite navigation systems (GNSS). This sentence provides fix data for GPS, GLONASS, possible future satellite systems and systems combining these.

\$- GNS, hhmmss.ss, llll.ll, a, yyyy.yy, a, c--c,xx,x.x,x.x,x.x,x.x,x.x,x.x,a *hh<CR><LF>

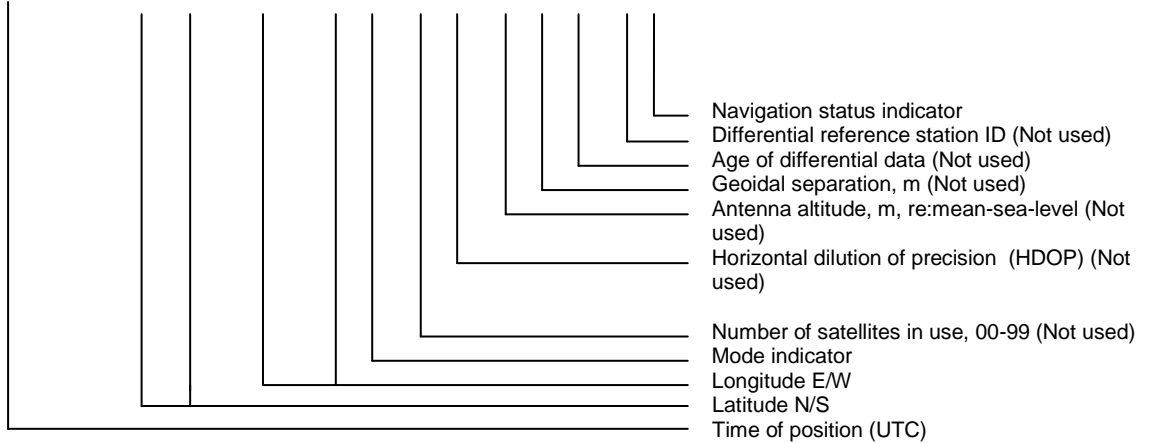

4.1.13 HBT Heart Beat

This sentence is intended to be used to indicate that equipment is operating normally, or for supervision of a connection between two units.

\$-HBT, x.x,A,x*hh <CR><LF>

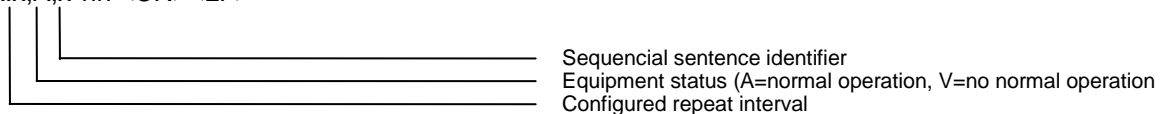



4.1.14 HDT - Heading true

IMO Resolutions A.424 and A.821. Actual vessel heading in degrees true produced by any device or system producing true heading

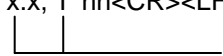
\$--HDT, x.x, T*hh<CR><LF>

Heading, degrees true

4.1.15 LRF - Long Range Function

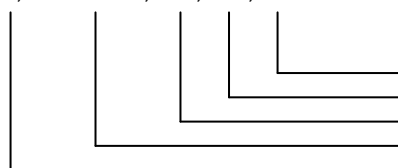
This sentence is used in both long-range interrogation requests and long-range interrogation replies.

\$--LRF,x,xxxxxxxx,c--c,c--c,c--c*hh<CR><LF>

Function reply status ¹
 Function request, 1 to 26 characters
 Name of requestor, 1 to 20 character string
 MMSI of requestor
 Sequence number , 0 to 9

Note 1:
 The "Function Reply Status" field provides the status characters for the "Function Request" information. When a long-range interrogation request is originated, the "Function Reply Status" field should be null. The "Function Reply Status" characters are organised in the same order as the corresponding function identification characters in the "Function Request" field. The following is a list of the "Function Reply Status" characters with the status they represent:
 2 = Information available and provided in the following LR1, LR2, or LR3 sentence,
 3 = Information not available from AIS unit,
 4 = Information is available but not provided (i.e. restricted access determined by ship's master),

4.1.16 LRI - Long-Range Interrogation

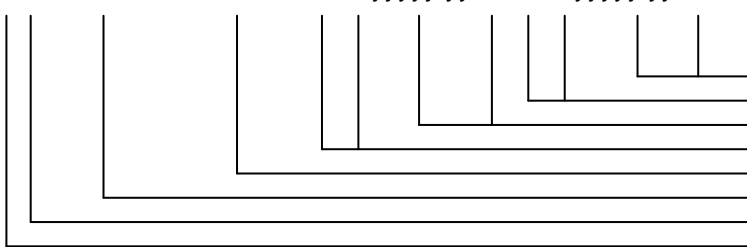
The long-range interrogation of the AIS is accomplished through the use of two sentences. The pair of interrogation sentences, a LRI-sentence followed by a LRF-sentence, provides the information needed by the AIS to determine if it must construct and provide the reply sentences (LRF, LR1, LR2, and LR3)

\$--LRI,x,a,xxxxxxxx,xxxxxxxx,llll.ll,a,yyyyy.yy,a,llll.ll,a,yyyyy.yy,a*hh<CR><LF>

Longitude - E/W (south-west co-ordinate)
 Latitude - N/S ("- " "- " "- " "- ")
 Longitude - E/W (north-east co-ordinate)
 Latitude - N/S ("- " "- " "- " "- ")
 MMSI of "destination"
 MMSI of "requestor"
 Control Flag
 Sequence number, 0-9



4.1.17 OSD Own ship data

IMO Resolution A.477 and MSC 64(67), Annex 1 and Annex 3. Heading, course, speed, set and drift summary. Useful for, but not limited to radar/ARPA applications. OSD gives the movement vector of the ship based on the sensors and parameters in use.

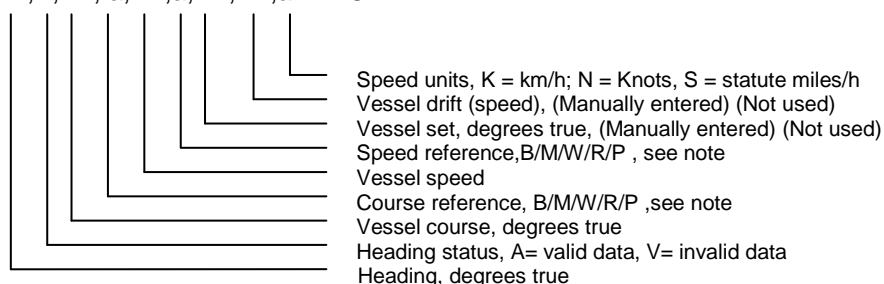
\$--OSD, x.x,A,x.x, a,x.x,a,x.x,x.x,a*hh<CR><LF>



4.1.18 RMC Recommended minimum specific GNSS data

Time, date, position, course and speed data provided by a GNSS navigation receiver. This sentence is transmitted at intervals not exceeding 2 s. All data fields must be provided, null fields used only when data is temporarily unavailable.

\$--RMC, hhmmss.ss, A, llll.ll,a, yyyy.yy, a, x.x, x.x, xxxxxx, x.x,a, a, a*hh<CR><LF>

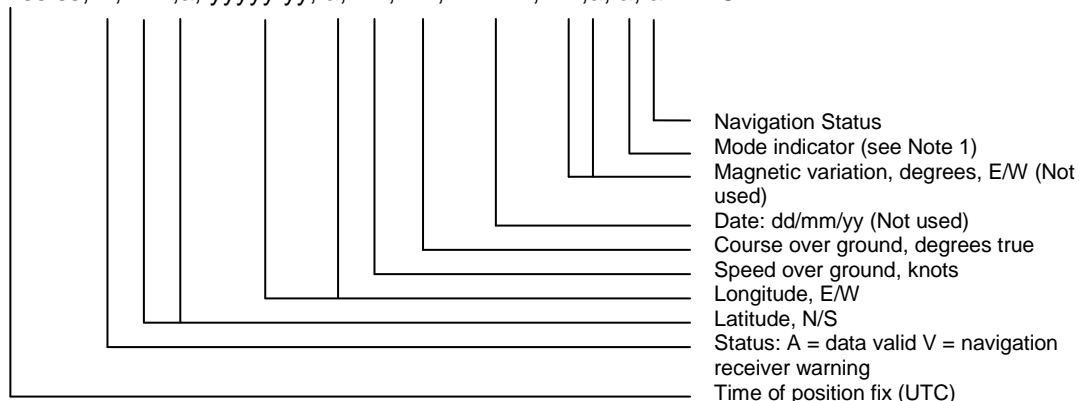

- Note 1:** Positioning system Mode indicator:
 A = Autonomous mode
 D = Differential mode
 E = Estimated (dead reckoning) mode
 M = Manual input mode
 S = Simulator mode
 N = No fix
 P = Precise
 R = Real time kinematic
 S = Simulator mode



4.1.19 ROT - Rate of turn

IMO Resolution A.526. Rate of turn and direction of turn.

`$--ROT, x.x, A*hh<CR><LF>`

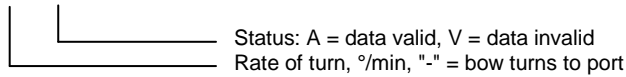

4.1.20 SPW - Security password sentence

This sentence can be used for authentication. For this purpose the sentence has to be applied before the protected sentence (for example EPV, SSD).

Other sentences may not be interleaved between the password sentence and protected sentence and the time between the SPW and the protected sentence should be limited. The password protected sentence pair should be sent without unnecessary delay between sentences. The recommendation is 1 s maximum timeout. Note that any of the signals may be lost and timed out.

If the password is not accepted (for example because it is incorrect) the command is refused using the NAK sentence.

`$--SPW,ccc,c--c,x,c--c*hh<CR><LF>`

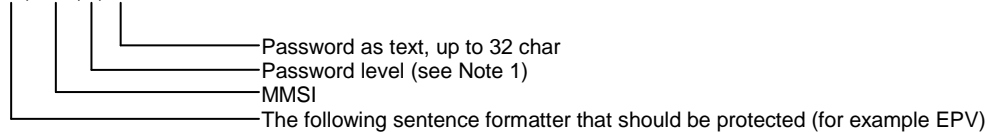

Note 1: An integer number as defined below:

- 1 = User level password
- 2 = Administrator level password
- 3-9 = Reserved

4.1.21 SSD - Station static data

This sentence is used to enter static parameters into a shipboard AIS. The parameters in this sentence support a number of the ITU-R M.1371 messages.

`$--SSD,c--c,c--c,xxx,xxx,xx,xx,c,aa*hh<CR><LF>`

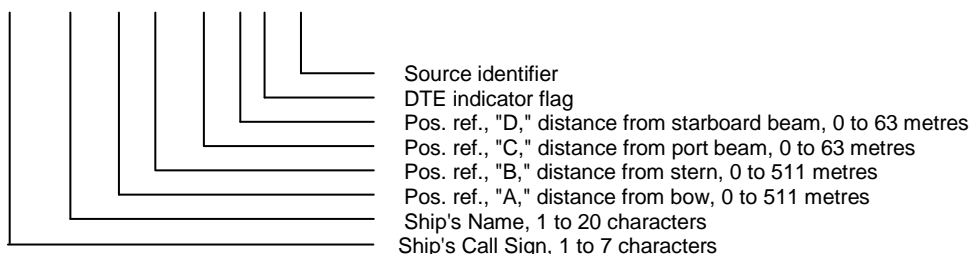



4.1.22 VBW - Dual ground/water speed

Water-referenced and ground-referenced speed data

\$--VBW, x.x, x.x, A, x.x, x.x, A, x.x, A, x.x, A*hh<CR><LF>

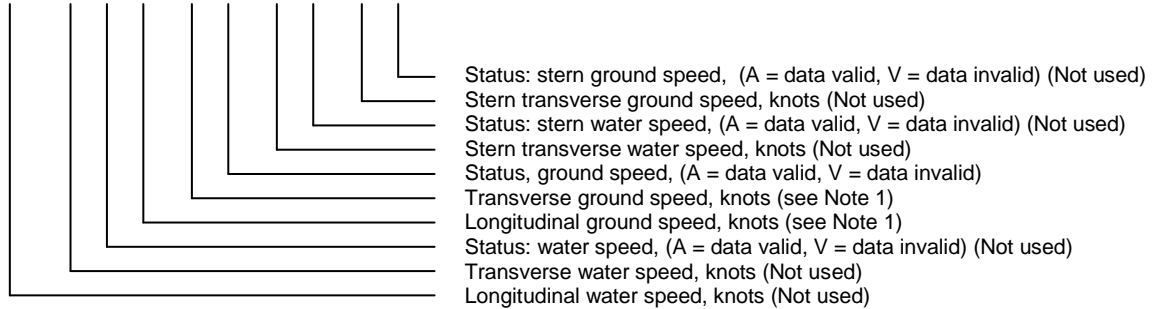

Note 1: Transverse speed: "-" = port, Longitudinal speed: "-" = astern.

4.1.23 VSD - Voyage Static Data

This sentence is used to enter information about a ship's voyage.

\$--VSD,x.x,x.x,x.x,c--c,hhmmss.ss,xx,xx,x.x,x.x*hh<CR><LF>

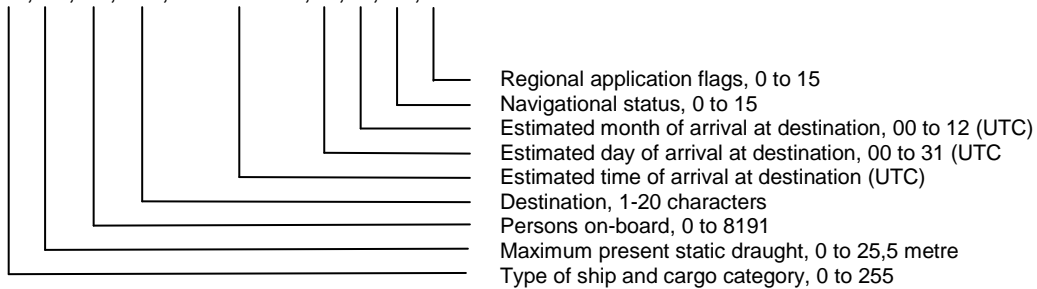

4.1.24 VTG - Course over ground and ground speed

The actual course and speed relative to the ground.

\$--VTG, x.x, T, x.x, M, x.x, N, x.x, K,a*hh<CR><LF>

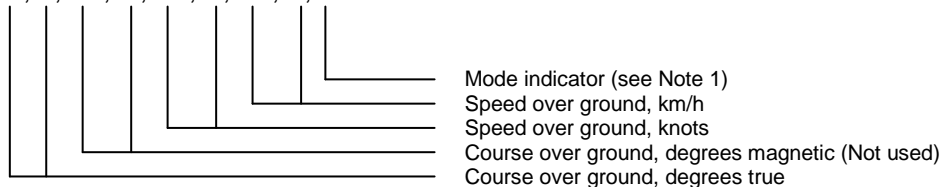

Note 1: Positioning system Mode indicator:

- A = Autonomous mode
- D = Differential mode
- E = Estimated (dead reckoning) mode
- M = Manual input mode
- P = Precise
- S = Simulator mode
- N = Data not valid

The positioning system Mode indicator field shall not be a null field.



4.1.25 ZDA - Time and date

UTC, day, month, year and local time zone.

\$-ZDA, hhmmss.ss, xx, xx, xxxx, xx, xx*hh<CR><LF>

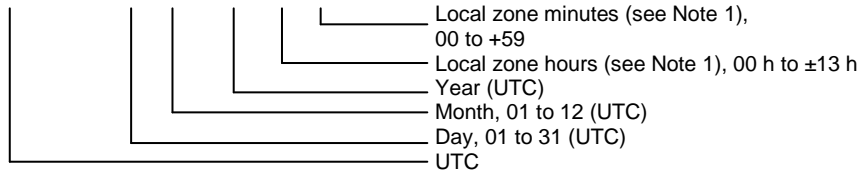

Note 1: Local time zone is the magnitude of hours plus the magnitude of minutes added, with the sign of local zone hours, to local time to obtain UTC. Local zone is generally negative for East longitudes with local exceptions near the international date line.

4.2 Output

All sentences starts with a delimiter that can be “\$” or “!” followed by the talker identifier indicated by “- -“. The talker identifier is AI for AIS.

4.2.1 ABK - Addressed and binary broadcast acknowledgement

The ABK-sentence is generated when a transaction, initiated by reception of an ABM, AIR, or BBM sentence is completed or terminated.

\$-ABK,xxxxxxxx,a,x,x,x,x*hh<CR><LF>

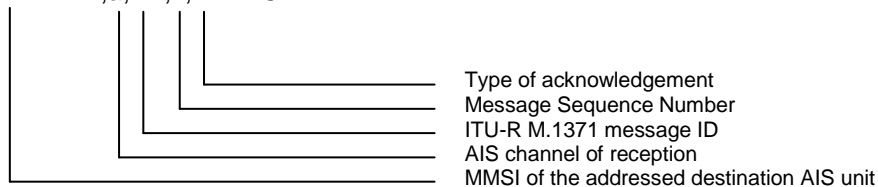

4.2.2 ACA - See “Input “

4.2.3 ALR - Set alarm state

Local alarm condition and status. This sentence is used to report an alarm condition on a device and its current state of acknowledgement.

\$-ALR,hhmmss.ss,xxx,A, A,c--c*hh<CR><LF>

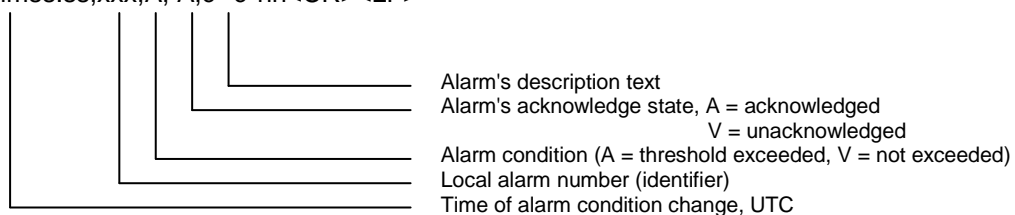



4.2.4 EPV - See "Input "

4.2.5 HBT - See "Input "

4.2.6 LRF - See "Input "

4.2.7 LR1 - Long-range Reply with destination for function request "A"

The LR1-sentence identifies the destination for the reply and contains the information requested by the "A" function identification character.

`$--LR1,x,xxxxxxxx,xxxxxxxx,c--c,c--c,xxxxxxxx*hh<CR><LF>`

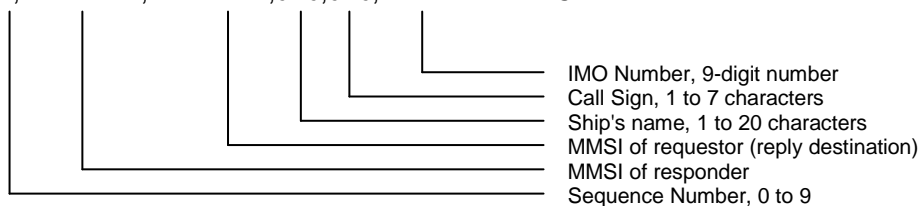

4.2.8 LR2 - Long-range Reply for function requests "B, C, E, and F"

The LR2-sentence contains the information requested by the "B, C, E, and F" function identification characters.

`$--LR2,x,xxxxxxxx,xxxxxxxx,hhmmss.ss,lll.ll,a,yyyy.yy,a,x.x,T,x.x,N*hh<CR><LF>`

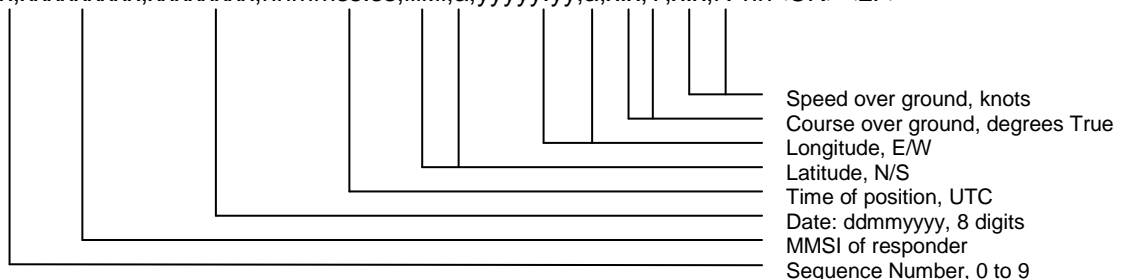

4.2.9 LR3 - Long-range Reply for function requests "I, O, P, U and W"

The LR3-sentence contains the information requested by the "I, O, P, U, and W" function identification characters

`$--LR3,x,xxxxxxxx,c--c,xxxxxx,hhmmss.ss,x.x,cc,x.x,x.x,x.x,x.x*hh<CR><LF>`

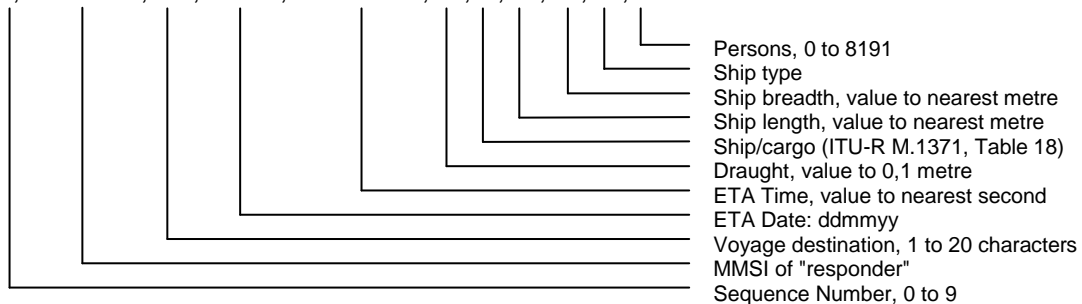



4.2.10 NAK – Negative acknowledgement

In general, the NAK sentence is used when a reply to a query sentence cannot be provided, or when a command sentence is not accepted. The NAK sentence reply should be generated within 1 s.

\$--NAK,cc,ccc,c--c,x,x,c--c*hh<CR><LF>

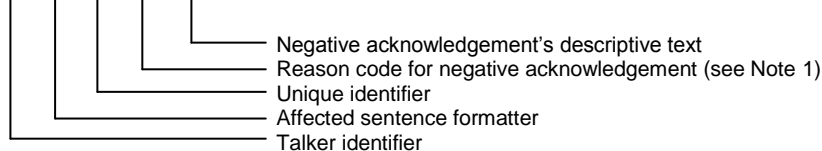

Note 1: Reason codes:

- 0 = query functionality not supported;
 - 1 = sentence formatter not supported;
 - 2 = sentence formatter supported, but not enabled;
 - 3 = sentence formatter supported and enabled, but temporarily unavailable (for instance, data field problem, unit in initialize state, or in diagnostic state, etc.);
 - 4 = sentence formatter supported, but query for this sentence formatter is not supported;
 - 5 = access denied, for sentence formatter requested;
 - 6 = sentence not accepted due to bad checksum;
 - 7 = sentence not accepted due to listener processing issue;
 - 8 to 9 = reserved for future use;
 - 10 = cannot perform the requested operation;
 - 11 = cannot fulfil request or command because of a problem with a data field in the sentence;
 - 12 to 48 = reserved for future use;
 - 49 = other reason as described in data field 5.
- Values greater than 50 may be defined by equipment standards.

4.2.11 TRL – AIS transmitter non functioning log

This sentence is used to output the logged “transmitter non-functioning” times. On a query (AIQ) for this sentence, up to 10 sentences will be output, one sentence for each logged non-functioning time.

This sentence is always generated as a response to a query even when no log entries exist.

\$--TRL,x,x,x,x,x,xxxxxxxx,hhmmss.ss,xxxxxxxx,hhmmss.ss,x,*hh<CR><LF>

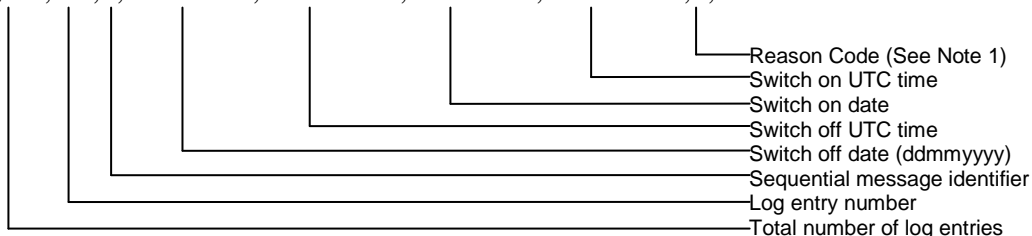

Note 1: Reason for Tx non-functioning:

- 1 = power off
- 2 = silent mode
- 3 = transmission switched off by channel management command
- 4 = equipment malfunction
- 5 = invalid configuration



4.2.12 TXT - Text transmission

For the transmission of short text messages. Longer text messages may be transmitted by using multiple sentences.

`$--TXT,xx,xx,xx,c--c*hh<CR><LF>`

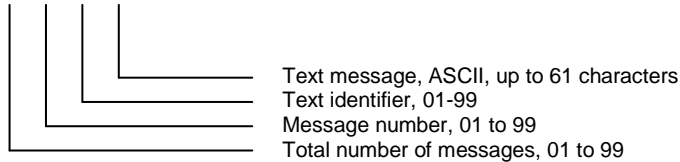

4.2.13 VDM - VHF Data-link Message

This sentence is used to transfer the entire contents of a received AIS message packet, as defined in ITU-R M.1371 and as received on the VHF Data Link (VDL), using the "6-bit" field type.

`!--VDM,x,x,x,a,s--s,x*hh<CR><LF>`

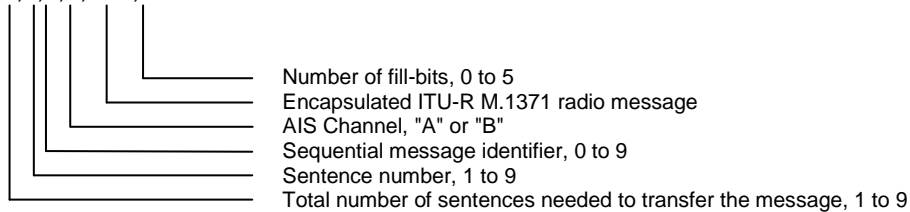

4.2.14 VDO - VHF Data-link Own-vessel message

This sentence is used to provide the information assembled for broadcast by the AIS. It uses the six-bit field type for encapsulation. The sentence uses the same structure as the VDM sentence formatter.

`!--VDO,x,x,x,a,s--s,x*hh<CR><LF>`

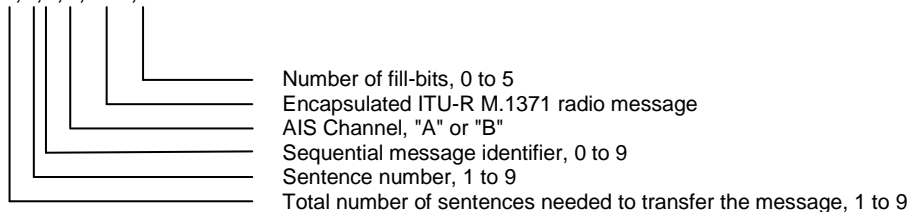



4.2.15 VER – Version

This sentence is used to provide identification and version information about a device. This sentence is produced as reply to a query sentence.

`$--VER,x,x,aa,c--c,c--c,c--c, c--c,c--c,c--c,x *hh <CR><LF>`

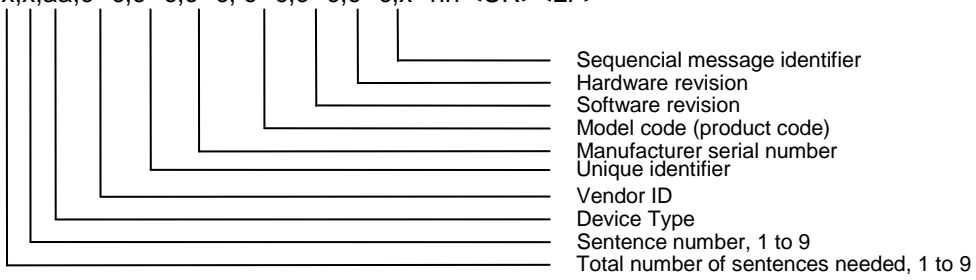



5 Abbreviations and Definitions

ACK	Acknowledge
AIS	Automatic Identification System - A shipborne broadcast transponder system in which ships continually transmit their position, course, speed and other data to other nearby ships and shoreline authorities on a common VHF radio channel.
AIS-SART	Automatic Identification System-Search And Rescue Transponder
AtoN	Aid to Navigation
BAUD	Transmission rate unit of measurement for binary coded data (bit per second).
BNC	Bayonet Neill-Concelman connector – common type of RF connector used for coaxial cable
BRG	Bearing
CPA	Closest Point of Approach
COG	Course Over Ground – Course made good relative to the sea bed.
DSC	Digital Selective Calling
DGNSS	Differential GNSS
DGPS	Differential GPS – A method of refining GPS position solution accuracy by modifying the locally computed position solution with correction signals from an external reference GPS CDU (monitor).
ECDIS	Electronic Chart Display and Information System for navigation approved to be used without paper charts
ECS	Electronic Chart System
EPFS	Electronic Position Fixing System (GPS is mostly used)
ETA	Estimated Time of Arrival. Calculated on basis of the distance to the destination and the current (or estimated) speed.
FM	Frequency Modulation - The method by which a signal offsets the frequency in order to modulate it on a data link.
GNSS	Global Navigation Satellite System – A common label for satellite navigation systems (such as GPS and GLONASS).
GPS	Global Positioning System – The NAVSTAR Global Positioning System, which consists of orbiting satellites, a network of ground control stations, and user positioning and navigation equipment. The system has 24 satellites plus 3 active spare satellites in six orbital planes about 20,200 kilometers above the earth.
GLONASS	A satellite navigation system developed and operated by Russia.
GMT	Greenwich Mean Time
GMDSS	Global Maritime Distress Safety System



HDG	Heading - The direction, in which the vessel is pointed, expressed as angular distance from north clockwise through 360 degrees. HEADING should not be confused with COURSE. The HEADING is constantly changing as the vessel yaws back and forth across the course due to the effects of sea, wind, and steering error.
IALA	International Association of Marine Aids to Navigation and Lighthouse Authorities
IEC	International Electro-technical Commission
IEC 61162-1	Maritime navigation and radio communication equipment and systems – Digital interfaces Single Talker- Multiple listeners: Closely related to NMEA0183 version 2.3, communication at 4800 baud. Definition of both electrical interface and protocol to be used.
IEC 61162-2	Maritime navigation and radio communication equipment and systems – Digital interfaces Single Talker- Multiple listeners, High speed transmission: Closely related to NMEA0183HS version 2.3, communication at 34800 baud. Definition of both electrical interface and protocol to be used.
IMO	International Maritime Organization
IP	Internet Protocol (IP) is the central, unifying protocol in the TCP/IP suite. It provides the basic delivery mechanism for packets of data sent between all systems on an internet, regardless of whether the systems are in the same room or on opposite sides of the world. All other protocols in the TCP/IP suite depend on IP to carry out the fundamental function of moving packets across the internet.
ISGOTT	International Safety Guide for Oil Tankers and Terminals
ITU	International Telecommunication Union
LAN	Local Area Network
LED	Light Emitting Diode
LCD	Liquid Crystal Display
LR	Long Range
NMEA	National Marine Electronics Association – The NMEA electronics interface specifications have been developed under the auspices of the Association. The NMEA 0183 is an internationally recognized specification for interfacing marine electronics. NMEA 0183 version 2.3 is almost identical to IEC 61162-1.
MKD	Minimum Keyboard and Display
MMSI	Maritime Mobile Service Identity
RCC	Rescue Coordination Centre
RF	Radio Frequency
RMS	ROOT MEAN SQUARED – A statistical measure of probability stating that an expected event will happen 68% of the time. In terms of position update accuracy, 68 position updates out of 100 will be accurate to within specified system accuracy.
ROT	Rate Of Turn



RNG	Range
RX	RX is the telegraph and radio abbreviation for “receive”
SAR	Search And Rescue
S/N	Signal-to-Noise ratio (SIN). Quantitative relationship between the useful and non-useful part of the received satellite signal. A high SIN indicates a good receiving condition.
SOG	Speed Over Ground – Speed in relation to the seabed.
SOTMA	Self Organized Time Division Multiple Access -An access protocol, which allows autonomous operation on a data link while automatically resolving transmission conflicts.
TCP	Transmission Control Protocol – Provides a reliable byte-stream transfer service between two end points on an internet. TCP depends on IP to move packets around the network on its behalf.
TCP/IP	TCP/IP is a name given to the collection (or <i>suite</i>) of networking protocols that have been used to construct the global Internet. The protocols are also referred to as the DoD (<i>dee-oh-dee</i>) or Arpanet protocol suite because their early development was funded by the Advanced Research Projects Agency (ARPA) of the US Department of Defense (DoD).
TCPA	Time to Closest Point of Approach
TI	Turn Indicator
TNC	Threaded Neill-Concelman connector – common type of RF connector used for coaxial cable
TX	TX is the telegraph and radio abbreviation for “transmit”
UDP	User Datagram Protocol – Provides a packetized data transfer service between end points on an internet. UDP depends on IP to move packets around the network on its behalf.
UTC	Universal Time Coordinated – Greenwich mean time corrected for polar motion of the Earth and seasonal variation in the Earth's rotation.
VDC	Volt DC
VDL	VHF Data Link
VHF	Very High Frequency – A set of frequencies in the MHz region
VSWR	Voltage standing wave ratio



CONTACT INFORMATION

Jotron AS (HQ)

P.O.Box 54
3281 Tjodalving
Norway
Tel: +47 33 13 97 00
Fax: +47 33 12 67 80
sales@jotron.com

Jotron AS

P.O.Box 23
3195 Skoppum
Norway
Tel: +47 33 13 97 00
Fax: +47 33 12 67 80
sales@jotron.com

Jotron AS

Dølasletta 7
3408 Tranby
Norway
Tel: +47 32 84 53 87
Fax: +47 32 84 55 30
sales@jotron.com

Jotron UK Ltd.

Crosland Park
Cramlington
NE23 1LA
United Kingdom
Tel: +44 (0) 1670 712000
Fax: +44 (0) 1670 590265
sales@jotron.com

Jotron Asia Pte. Ltd.

19 Loyang Way
Changi Logistics Centre
Rear Office Block 04-26
Singapore 508724
Tel: +65 65426350
Fax: +65 65429415
sales@jotron.com

Jotron USA, Inc.

10645 Richmond Avenue
Suite 170
Houston, TX 77042
USA
Tel: +1 713 268 1061
Fax: +1 713 268 1062
sales@jotron.com

