



Test Report

Product Name : HSUPA PCI Express mini card module
Model No : H20
FCC ID : VRSH20

Applicant : Qisda Corporation
Address : 157, Shan-Ying Road, Gueishan,
Taoyuan 333, Taiwan, R.O.C.

Date of Receipt : 2008/12/08
Issued Date : 2009/02/19
Report No. : 08C126R-HPUSP07V01
Reference No. : BW-9930
Version : V1.0

The test results relate only to the samples tested.
The test report shall not be reproduced except in full without the written approval of Quie Tek Corporation.
This report must not be used to claim product endorsement by NVLAP any agency of the U.S. Government

Test Report Certification

Issued Date : 2009/02/19

Report No.: 08C126R-HPUSP07V01



Accredited by NIST (NVLAP)

NVLAP Lab Code: 200533-0

Product Name : HSUPA PCI Express mini card module
Applicant : Qisda Corporation
Address : 157, Shan-Ying Road, Gueishan, Taoyuan 333, Taiwan,
: R.O.C.
Manufacturer : Qisda Corporation
Trade Name : Qisda
Model No. : H20
Rated Voltage : DC 3.3V
Measurement Standard : FCC CFR Title 47 Part 2 22 24
Measurement Reference : TIA/EIA 603-C
Test Result : Complied

Test results relate only to the samples tested.

The test report shall not be reproduced except in full without the written approval of Quie Tek Corporation.

This report must not be used to claim product endorsement by NVLAP any agency of the U.S. Government

Documented By :

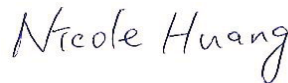

(Engineering Adm. Assistant /
Nicole Huang)

Tested By :



(Engineer / Vorana Chen)

Approved By :



(Manager / Vincent Lin)

TABLE OF CONTENTS

Description	Page
1. GENERAL INFORMATION	4
1.1. EUT Description	4
1.2. Antenna List.....	5
1.3. Operational Description.....	6
1.4. Configuration of tested System	7
1.5. EUT Setup Procedures	7
1.6. Test Facility	8
1.7. Type of Emission	9
2. Peak Power Output	10
2.1. Test Equipment.....	10
2.2. Test Setup	10
2.3. Limits	11
2.4. Test Procedure.....	11
2.5. Test Specification	11
2.6. Test Result of Peak Power Output.....	12
3. Occupied Bandwidth.....	25
3.1. Test Equipment.....	25
3.2. Test Setup	25
3.3. Test Procedure.....	25
3.4. Test Specification	26
3.5. Test Result of Occupied Bandwidth	27
4. Spurious Emission At Antenna Terminals (+/-1MHz)	47
4.1. Test Equipment.....	47
4.2. Setup	47
4.3. Limits	48
4.4. Test Procedure.....	48
4.5. Test Specification	48
4.6. Test Result of Spurious Emission At Antenna Terminals (+/-1MHz).....	49
5. Spurious Emission	59
5.1. Test Equipment.....	59
5.2. Test Setup	60
5.3. Limits	60
5.4. Test Procedure.....	61
5.5. Test Specification	61
5.6. Test Result of Spurious Emission	62
6. Frequency Stability Under Temperature & Voltage Variations	102
6.1. Test Equipment	102
6.2. Test Setup	102
6.3. Limits.....	102
6.4. Test Procedure	103
6.5. Test Specification.....	103
6.6. Test Result of Frequency Stability Under Temperature Variations	104
7. EMI Reduction Method During Compliance Testing	114
Attachment 1: EUT Test Photographs	
Attachment 2: EUT Detailed Photographs	

1. GENERAL INFORMATION

1.1. EUT Description

Product Name	HSUPA PCI Express mini card module
Model No.	H20
Trade Name	Qisda
IMEI No.	353030020000741
FCC ID.	VRSH20
Antenna Type	PIFA
TX Frequency	824MHz~849MHz(GSM 850/WCDMA Band V) 1850MHz ~ 1910MHz(PCS 1900/WCDMA Band II)
Rx Frequency	869MHz~894MHz(GSM 850/WCDMA Band V) 1930MHz ~ 1990MHz(PCS 1900/WCDMA Band II)
Function	GPRS/EGPRS/WCDMA/HSDPA/HSUPA
Hardware version	4H.0JA01.S05
Software version	1.0

1.2. Antenna List

No.	Antenna Type	Model No.	Peak Gain
1	PIFA	TN12R	-3.11 dBi
2	PIFA	M860TU	0.82 dBi
3	PIFA	M770SU	2.79 dBi
4	PIFA	M760S	1.70 dBi
5	PIFA	M760J	1.70 dBi
6	PIFA	M740S	2.83 dBi
7	PIFA	M740J	2.83 dBi
8	PIFA	M735T	2.02 dBi
9	PIFA	M730T	1.22 dBi
10	PIFA	M720T	1.11 dBi
11	PIFA	M810L-1-2	2.49 dBi
12	PIFA	M810L-1-2	2.12 dBi
13	PIFA	W760S	1.7 dBi
14	PIFA	T120R/T	-3.33 dBi
15	PIFA	R130T	2.12 dBi

Note: 1. Regarding to the operation frequency, the lowest, middle and highest frequency are selected to perform the test.

2. Only the higher gain antenna Ant 6 was tested and recorded in this report.

1.3. Operational Description

The information contained within this report is intended to show verification of compliance of the 850/1900MHz Notebook to the requirements of 47CFR2, 22 and 24.

The EUT provide all functions described as above. The EUT is tested with maximum rated TX power via the Base Station simulator.

Quietek has verified the construction and function in typical operation. All the test modes were carried out with the EUT in normal operation, which was shown in this test report and defined as:

Test Mode:	GSM 850 GPRS
	GSM 850 EGPRS
	PCS 1900 GPRS
	PCS 1900 EGPRS
	WCDMA BAND V
	WCDMA BAND V HSDPA
	WCDMA BAND V HSUPA
	WCDMA BAND II
	WCDMA BAND II HSDPA
	WCDMA BAND II HSUPA

1.4. Configuration of tested System

(a) Configuration of Radiated measurement

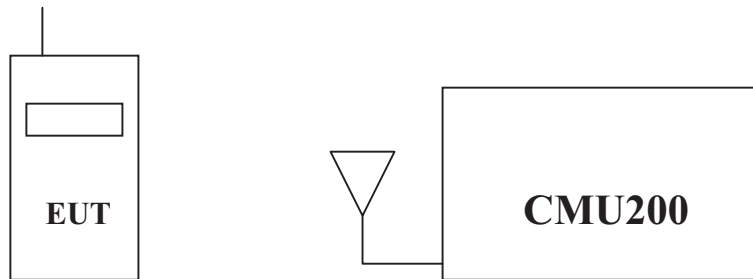

(b) Configuration of Conducted measurement

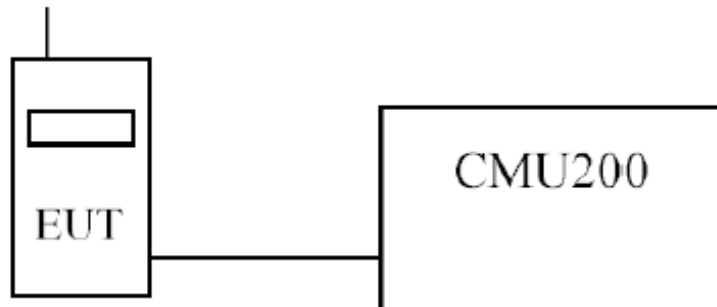

1.5. EUT Setup Procedures

- (1) Setup the EUT and simulators as shown on 1.4
- (2) Turn on the power of all equipments.
- (3) The EUT was set to communicate with CMU200.
- (4) Repeat the above procedure (3).

1.6. Test Facility

Ambient conditions in the laboratory:

Items	Required (IEC 68-1)	Actual
Temperature (°C)	15-35	21
Humidity (%RH)	25-75	53
Barometric pressure (mbar)	860-1060	982

Site Description: File on
 Federal Communications Commission
 FCC Engineering Laboratory
 7435 Oakland Mills Road
 Columbia, MD 21046
 FCC Registration Number :92195



July 03, 2001 Accreditation on NVLAP
 NVLAP Lab Code: 200533-0



Site Name: Quietek Corporation

LinKou Testing Laboratory:
 No. 5, Ruei-Shu Valley, Ruei-Ping Tsuen,
 Lin-Kou Shiang, Taipei,
 Taiwan, R.O.C.
 TEL : 886-2-8601-3788 / FAX : 886-2-8601-3789
 E-Mail : service@quietek.com

FCC Accreditation Number: TW1014



1.7. Type of Emission

GPRS/EGPRS: 300KG7W

WCDMA/HSDPA/HSUPA: 5M00F9W

2. Peak Power Output

2.1. Test Equipment

The following test equipments are used during the radiated emission test:

Test Site	Equipment	Manufacturer	Model No./Serial No.	Last Cal.
☒OATS 3	Test Receiver	R & S	ESCS 30 / 100122	Feb., 2009
	Universal Radio Communication Tester	R & S	CMU200 / 104846	Apr., 2008
	Spectrum Analyzer	Agilent	N9020A/ MY48010570	Apr., 2008
	Pre-Amplifier	QTK	QTK-AMP-03 / 0003	May., 2008
	Bilog Antenna	SCHAFFNER	CBL6112B / 2697	May., 2008
	Horn Antenna	ETS	3115 / 0005-6160	Jul., 2008
	Pre-Amplifier	QTK	QTK-AMP-01 / 0001	Jul., 2008

- Note: 1. All equipments that need to be calibrated are with calibration period of 1 year.
 2. Mark "X" test instruments are used to measure the final test results.

2.2. Test Setup

Radiated Power Measurement

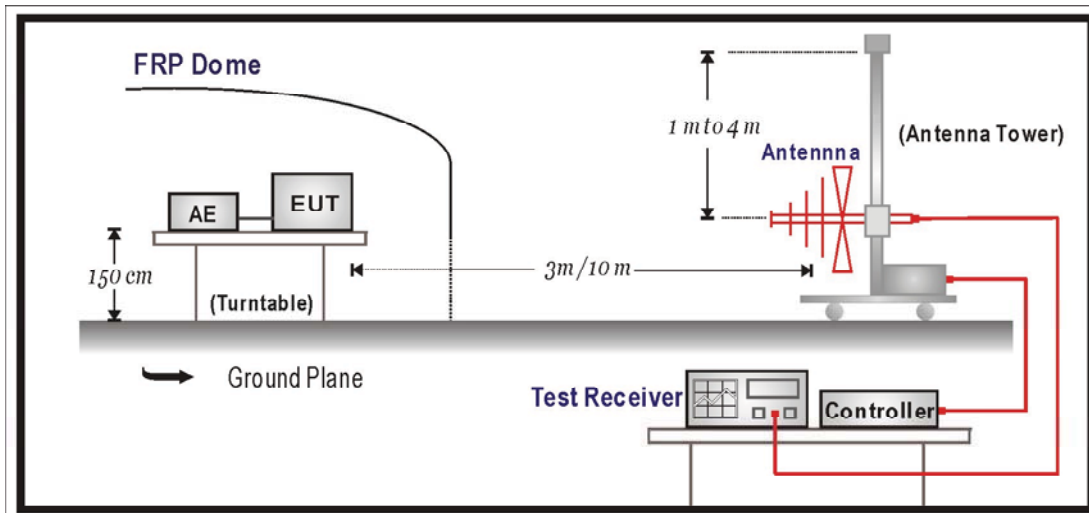

Conducted Power Measurement

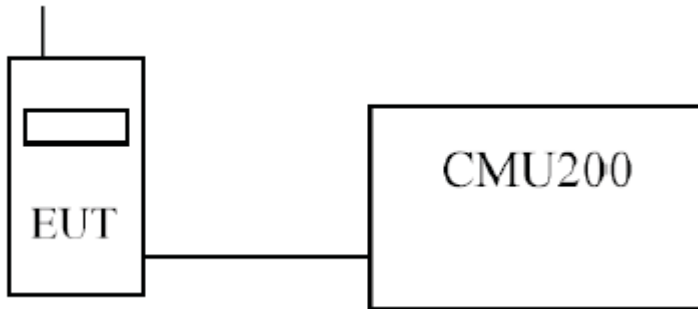

2.3. Limits

Cellular Band 850	<7W
PCS Band 1900	<2W or +33dBm

2.4. Test Procedure

➤RF Out Power (Radiated)

The Spectrum Analyzer was tuned to the test frequency. The device was put into Transmit mode then rotated through 360 degrees until the highest power level was observed in both horizontal and vertical polarization. The device was then replaced with a substitution antenna, which input signal was adjusted until the received level matched that of the previously detected emission.

The EUT is tested with maximum rated TX power via the Base Station simulator.

➤RF Out Power (Conducted)

The EUT is tested with maximum rated TX power via the Base Station simulator, and the output power was measured at the antenna terminals of the EUT.

2.5. Test Specification

According to Part 2.1046, 22.913,24.232.

2.6. Test Result of Peak Power Output

Product	HSUPA PCI Express mini card module		
Test Mode	RF Output Power (Conducted)		
Date of Test	2009/02/18	Test Site	CTR

GPRS 850				
Frequency (MHz)	Output Power (dBm)	Path Loss (dB)	Result (dBm)	Result (W)
824.2	32.23	0.4	32.63	1.83
836.4	32.03	0.4	32.43	1.75
848.8	31.81	0.4	32.21	1.66
GPRS 1900				
Frequency (MHz)	Output Power (dBm)	Path Loss (dB)	Result (dBm)	Result (W)
1850.2	28.45	0.6	29.05	0.80
1880	28.3	0.6	28.90	0.78
1909.8	28.36	0.6	28.96	0.79
EGPRS 850				
Frequency (MHz)	Output Power (dBm)	Path Loss (dB)	Result (dBm)	Result (W)
824.2	26.62	0.4	27.02	0.50
836.4	26.47	0.4	26.87	0.49
848.8	26.41	0.4	26.81	0.48
EGPRS 1900				
Frequency (MHz)	Output Power (dBm)	Path Loss (dB)	Result (dBm)	Result (W)
1850.2	24.93	0.6	25.53	0.36
1880	24.82	0.6	25.42	0.35
1909.8	24.79	0.6	25.39	0.35

WCDMA V(Power Control: All Up)				
Frequency (MHz)	Output Power (dBm)	Path Loss (dB)	Result (dBm)	Result (W)
824.2	22.67	0.4	23.07	0.20
836.4	22.44	0.4	22.84	0.19
848.8	22.78	0.4	23.18	0.21
WCDMA II(Power Control: All Up)				
Frequency (MHz)	Output Power (dBm)	Path Loss (dB)	Result (dBm)	Result (W)
1850.2	22.54	0.6	23.14	0.21
1880	22.06	0.6	22.66	0.18
1909.8	22.55	0.6	23.15	0.21

WCDMA V HSDPA								
Frequency (MHz)	Set 1		Set 2		Set 3		Set 4	
	Power (dBm)	Power (Watts)	Power (dBm)	Power (Watts)	Power (dBm)	Power (Watts)	Power (dBm)	Power (Watts)
824.2	23.21	0.21	22.39	0.17	22.28	0.17	21.73	0.15
836.4	22.83	0.19	22.15	0.16	22.09	0.16	21.56	0.14
848.8	22.92	0.20	22.40	0.17	22.27	0.17	21.86	0.15
β_c	2		12		15		15	
β_d	15		15		8		4	
$\Delta_{ACK}, \Delta_{NACK} \Delta_{CQI}$	8		8		8		8	
Cable loss: 0.4dB for 850MHz ; 0.6dB for 1900MHz								

All HSDPA testing was done in Set5 configuration.

WCDMA II HSDPA								
Frequency (MHz)	Set 1		Set 2		Set 3		Set 4	
	Power (dBm)	Power (Watts)	Power (dBm)	Power (Watts)	Power (dBm)	Power (Watts)	Power (dBm)	Power (Watts)
1850.2	23.79	0.24	22.91	0.20	23.80	0.24	23.35	0.22
1880	22.21	0.17	21.68	0.15	22.27	0.17	21.53	0.14
1909.8	23.59	0.23	22.81	0.19	23.49	0.22	23.37	0.22
β_c	2		12		15		15	
β_d	15		15		8		4	
$\Delta_{ACK}, \Delta_{NACK} \Delta_{CQI}$	8		8		8		8	
Cable loss: 0.4dB for 850MHz ; 0.6dB for 1900MHz								

All HSDPA testing was done in Set1 configuration.

WCDMA V HSUPA										
Frequency (MHz)	Set 1		Set 2		Set 3		Set 4		Set 5	
	Power (dBm)	Power (Watts)	Power (dBm)	Power (Watts)	Power (dBm)	Power (Watts)	Power (dBm)	Power (Watts)	Power (dBm)	Power (Watts)
824.2	22.39	0.17	22.86	0.19	22.08	0.16	22.88	0.19	23.08	0.20
836.4	22.14	0.16	22.68	0.19	22.12	0.16	22.69	0.19	22.58	0.18
848.8	22.42	0.17	23.00	0.20	22.35	0.17	22.82	0.19	22.83	0.19
β_c	11		6		15		2		15	
β_d	15		15		9		15		15	
$\Delta_{ACK}, \Delta_{NACK} \Delta_{CQI}$	8		8		8		8		8	
AGV	20		12		15		17		21	
Cable loss: 0.4dB for 850MHz ; 0.6dB for 1900MHz										

All HSUPA testing was done in Set5 configuration.

WCDMA II HSUPA										
Frequency (MHz)	Set 1		Set 2		Set 3		Set 4		Set 5	
	Power (dBm)	Power (Watts)	Power (dBm)	Power (Watts)	Power (dBm)	Power (Watts)	Power (dBm)	Power (Watts)	Power (dBm)	Power (Watts)
1850.2	23.64	0.23	23.87	0.24	23.74	0.24	23.23	0.21	23.74	0.24
1880	22.12	0.16	22.63	0.18	22.41	0.17	22.41	0.17	22.77	0.19
1909.8	23.66	0.23	23.51	0.22	23.52	0.22	23.52	0.22	23.58	0.23
β_c	11		6		15		2		15	
β_d	15		15		9		15		15	
$\Delta_{ACK}, \Delta_{NACK} \Delta_{CQI}$	8		8		8		8		8	
AGV	20		12		15		17		21	
Cable loss: 0.4dB for 850MHz ; 0.6dB for 1900MHz										

Note: All HSUPA testing was done in Set5 configuration.

Product	HSUPA PCI Express mini card module		
Test Mode	RF Output Power (Radiated)		
Date of Test	2009/02/18	Test Site	OATS 3
Test Condition	GSM 850 GPRS		

Maximum Power-GSM 850 GPRS

Frequency (MHz)	Reading Level (dBm)	Substitution Level (dBm)	Substitution Antenna Gain (dBd)	Cable Loss (dB)	Result ERP (dBm)	Result ERP (W)
824.2	4.36	7.23	4.45	0.51	11.17	0.01
836.4	5.58	8.46	4.45	0.51	12.40	0.02
848.8	8.06	10.94	4.45	0.51	14.88	0.03

Note:

1. The EUT meets the requirements of FCC CFR 47: Part 22, Section 22.913(a) for Effective Radiated Power.
2. Receiver setting (Peak Detector) : RBW:3MHz; VBW:3MHz
3. Result ERP = Substitution Level + Substitution Antenna Gain - Cable Loss

Product	HSUPA PCI Express mini card module		
Test Mode	RF Output Power (Radiated)		
Date of Test	2009/02/18	Test Site	OATS 3
Test Condition	PCS 1900 GPRS		

Maximum Power-PCS 1900 GPRS

Frequency (MHz)	Reading Level (dBm)	Substitution Level (dBm)	Substitution Antenna Gain (dBi)	Cable Loss (dB)	Result EIRP (dBm)	Result EIRP (W)
1850.2	-14.700	17.678	10.4	1.02	27.058	0.51
1880.0	-15.390	17.36	10.4	1.02	26.740	0.47
1909.8	-16.280	16.712	10.4	1.02	26.092	0.41

Note:

1. The EUT meets the requirements of FCC CFR 47: Part 24, Section 24.232(b) for Effective Isotropically radiated power.
2. Receiver setting (Peak Detector) : RBW:3MHz; VBW:3MHz
3. Result EIRP = Substitution Level + Substitution Antenna Gain - Cable Loss

Product	HSUPA PCI Express mini card module		
Test Mode	RF Output Power (Radiated)		
Date of Test	2009/02/18	Test Site	OATS 3
Test Condition	GSM 850 EGPRS		

Maximum Power-GSM 850 EGPRS

Frequency (MHz)	Reading Level (dBm)	Substitution Level (dBm)	Substitution Antenna Gain (dBd)	Cable Loss (dB)	Result ERP (dBm)	Result ERP (W)
824.2	2.11	4.96	4.45	0.51	8.90	0.01
836.4	3.35	6.21	4.45	0.51	10.15	0.01
848.8	5.76	8.64	4.45	0.51	12.58	0.02

Note:

1. The EUT meets the requirements of FCC CFR 47: Part 22, Section 22.913(a) for Effective Radiated Power.
2. Receiver setting (Peak Detector) : RBW:3MHz; VBW:3MHz
3. Result EIRP = Substitution Level + Substitution Antenna Gain - Cable Loss

Product	HSUPA PCI Express mini card module		
Test Mode	RF Output Power (Radiated)		
Date of Test	2009/02/18	Test Site	OATS 3
Test Condition	PCS 1900 EGPRS		

Maximum Power-PCS 1900 EGPRS

Frequency (MHz)	Reading Level (dBm)	Substitution Level (dBm)	Substitution Antenna Gain (dBi)	Cable Loss (dB)	Result EIRP (dBm)	Result EIRP (W)
1850.2	-15.100	17.278	10.4	1.02	26.658	0.46
1880.0	-15.880	16.87	10.4	1.02	26.250	0.42
1909.8	-16.750	16.242	10.4	1.02	25.622	0.36

Note:

1. The EUT meets the requirements of FCC CFR 47: Part 24, Section 24.232(b) for Effective Isotropically Radiated Power.
2. Receiver setting (Peak Detector) : RBW:3MHz; VBW:3MHz
3. Result EIRP = Substitution Level + Substitution Antenna Gain - Cable Loss

Product	HSUPA PCI Express mini card module		
Test Mode	RF Output Power (Radiated)		
Date of Test	2009/02/18	Test Site	OATS 3
Test Condition	WCDMA BAND V RMC Link		

Maximum Power- WCDMA BAND V RMC Link

Frequency (MHz)	Reading Level (dBm)	Substitution Level (dBm)	Substitution Antenna Gain (dBd)	Cable Loss (dB)	Result ERP (dBm)	Result ERP (W)
826.4	-0.68	2.18	4.45	0.51	6.12	0.00409
836.6	-0.26	2.60	4.45	0.51	6.54	0.00451
846.6	-0.73	2.13	4.45	0.51	6.07	0.00405

Note:

1. The EUT meets the requirements of FCC CFR 47: Part 22, Section 22.913(a) for Effective Radiated Power.
2. Receiver setting (Peak Detector) : RBW:5MHz; VBW:5MHz
3. Result ERP = Substitution Level + Substitution Antenna Gain - Cable Loss

Product	HSUPA PCI Express mini card module		
Test Mode	RF Output Power (Radiated)		
Date of Test	2009/02/18	Test Site	OATS 3
Test Condition	WCDMA BAND V HSDPA Link		

Maximum Power- WCDMA BAND V HSDPA Link

Frequency (MHz)	Reading Level (dBm)	Substitution Level (dBm)	Substitution Antenna Gain (dBd)	Cable Loss (dB)	Result ERP (dBm)	Result ERP (W)
826.4	-0.67	2.19	4.45	0.51	6.13	0.00410
836.6	-0.27	2.59	4.45	0.51	6.53	0.00450
846.6	-0.72	2.14	4.45	0.51	6.08	0.00406

Note:

1. The EUT meets the requirements of FCC CFR 47: Part 22, Section 22.913(a) for Effective Radiated Power.
2. Receiver setting (Peak Detector) : RBW:5MHz; VBW:5MHz
3. Result ERP = Substitution Level + Substitution Antenna Gain - Cable Loss

Product	HSUPA PCI Express mini card module		
Test Mode	RF Output Power (Radiated)		
Date of Test	2009/02/18	Test Site	OATS 3
Test Condition	WCDMA BAND V HSUPA Link		

Maximum Power- WCDMA BAND V HSUPA Link

Frequency (MHz)	Reading Level (dBm)	Substitution Level (dBm)	Substitution Antenna Gain (dBd)	Cable Loss (dB)	Result ERP (dBm)	Result ERP (W)
826.4	-0.64	2.22	4.45	0.51	6.16	0.00413
836.6	-0.04	2.82	4.45	0.51	6.76	0.00474
846.6	-0.82	2.04	4.45	0.51	5.98	0.00396

Note:

1. The EUT meets the requirements of FCC CFR 47: Part 22, Section 22.913(a) for Effective Radiated Power.
2. Receiver setting (Peak Detector) : RBW:5MHz; VBW:5MHz
3. Result ERP = Substitution Level + Substitution Antenna Gain - Cable Loss

Product	HSUPA PCI Express mini card module		
Test Mode	RF Output Power (Radiated)		
Date of Test	2009/02/18	Test Site	OATS 3
Test Condition	WCDMA BAND II RMC Link		

Maximum Power- WCDMA BAND II RMC Link

Frequency (MHz)	Reading Level (dBm)	Substitution Level (dBm)	Substitution Antenna Gain (dBi)	Cable Loss (dB)	Result EIRP (dBm)	Result EIRP (W)
1852.4	-21.450	10.955	10.4	1.02	20.335	0.11
1880	-20.860	11.89	10.4	1.02	21.270	0.13
1907.6	-20.800	12.194	10.4	1.02	21.574	0.14

Note:

1. The EUT meets the requirements of FCC CFR 47: Part 24, Section 24.232(b) for Effective Isotropically Radiated Power.
2. Receiver setting (Peak Detector) : RBW:5MHz; VBW:5MHz
3. Result EIRP = Substitution Level + Substitution Antenna Gain - Cable Loss

Product	HSUPA PCI Express mini card module		
Test Mode	RF Output Power (Radiated)		
Date of Test	2009/02/18	Test Site	OATS 3
Test Condition	WCDMA BAND II HSDPA Link		

Maximum Power- WCDMA BAND II HSDPA Link

Frequency (MHz)	Reading Level (dBm)	Substitution Level (dBm)	Substitution Antenna Gain (dBi)	Cable Loss (dB)	Result EIRP (dBm)	Result EIRP (W)
1852.4	-21.600	10.805	10.4	1.02	20.185	0.10
1880	-19.990	12.76	10.4	1.02	22.140	0.16
1907.6	-20.930	12.064	10.4	1.02	21.444	0.14

Note:

1. The EUT meets the requirements of FCC CFR 47: Part 24, Section 24.232(b) for Effective Isotropically Radiated Power.
2. Receiver setting (Peak Detector) : RBW:5MHz; VBW:5MHz
3. Result EIRP = Substitution Level + Substitution Antenna Gain - Cable Loss

Product	HSUPA PCI Express mini card module		
Test Mode	RF Output Power (Radiated)		
Date of Test	2009/02/18	Test Site	OATS 3
Test Condition	WCDMA BAND II HSUPA Link		

Maximum Power- WCDMA BAND II HSUPA Link

Frequency (MHz)	Reading Level (dBm)	Substitution Level (dBm)	Substitution Antenna Gain (dBi)	Cable Loss (dB)	Result EIRP (dBm)	Result EIRP (W)
1852.4	-21.610	10.795	10.4	1.02	20.175	0.10
1880	-20.670	12.08	10.4	1.02	21.460	0.14
1907.6	-20.960	12.034	10.4	1.02	21.414	0.14

Note:

1. The EUT meets the requirements of FCC CFR 47: Part 24, Section 24.232(b) for Effective Isotropically Radiated Power.
2. Receiver setting (Peak Detector) : RBW:5MHz; VBW:5MHz
3. Result EIRP = Substitution Level + Substitution Antenna Gain - Cable Loss

3. Occupied Bandwidth

3.1. Test Equipment

The following test equipments are used during the occupied bandwidth tests:

Equipment	Manufacturer	Model No./Serial No.	Last Cal.
Spectrum Analyzer	Agilent	N9020A/ MY48010570	Apr., 2008
Universal Radio Communication Tester	R & S	CMU200 / 104846	Apr., 2008
Directional coupler	Agilent	87300C / MY44300353	Aug., 2008
Directional coupler	Agilent	778D-012/ 50550	Aug., 2008

Note: All equipments upon which need to be calibrated are with calibration period of 1 year.

3.2. Test Setup

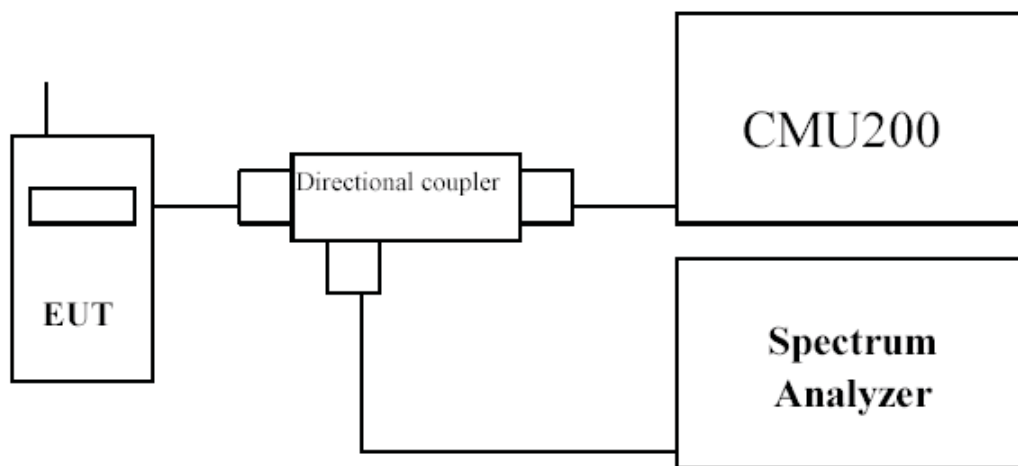

3.3. Test Procedure

The EUT is tested with maximum rated TX power via the Base Station simulator, and the occupied bandwidth was measured at the antenna terminals of the EUT.

The Resolution BW of the analyzer is set to 1 % of the emission bandwidth. The EUT's occupied bandwidth is measured as the width of the signal between two points, one below the carrier center frequency and one above the carrier frequency, outside of which all emissions are attenuated at least 26 dB below the transmitter power.

The plots below show the resultant display from the Spectrum Analyzer.

3.4. Test Specification

According to Part 2.1049, 22.917(b), 24.238(b).

3.5. Test Result of Occupied Bandwidth

Product	HSUPA PCI Express mini card module		
Test Mode	Occupied Bandwidth		
Date of Test	2009/02/18	Test Site	CTR
Test Condition	GSM 850 GPRS		

GSM 850 GPRS - Packet Switched (GSM Mode CH 128)

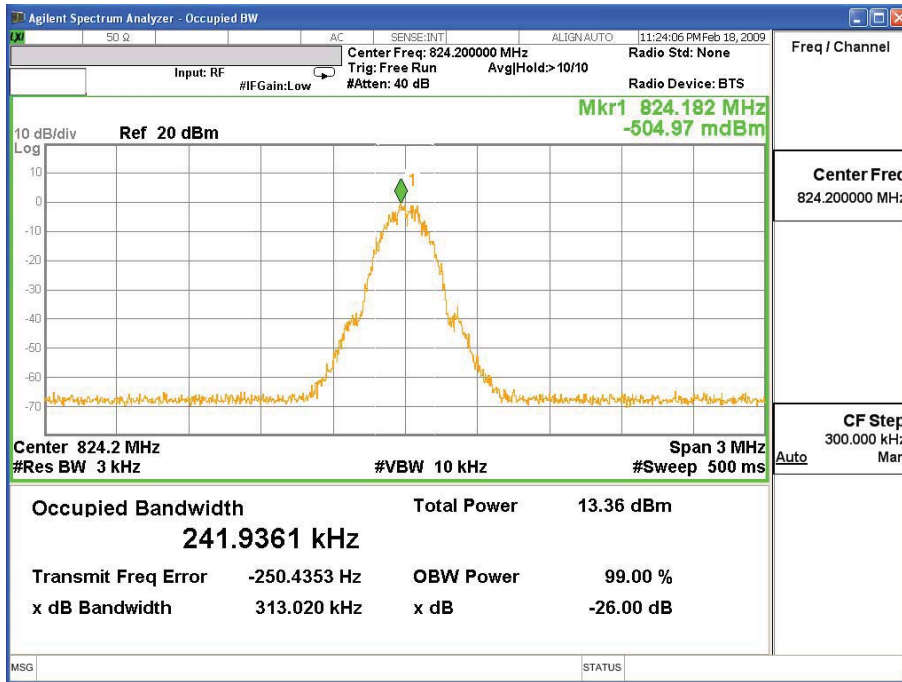

GSM 850 GPRS - Packet Switched (GSM Mode CH189)

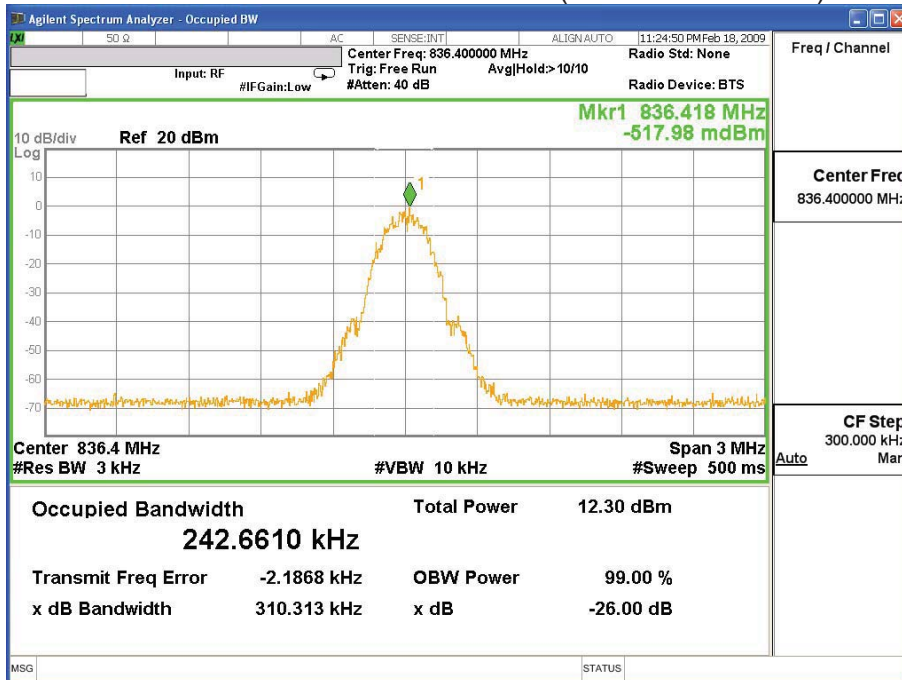

Product	HSUPA PCI Express mini card module		
Test Mode	Occupied Bandwidth		
Date of Test	2009/02/18	Test Site	CTR
Test Condition	GSM 850 GPRS		

GSM 850 GPRS - Packet Switched (GSM Mode CH 251)

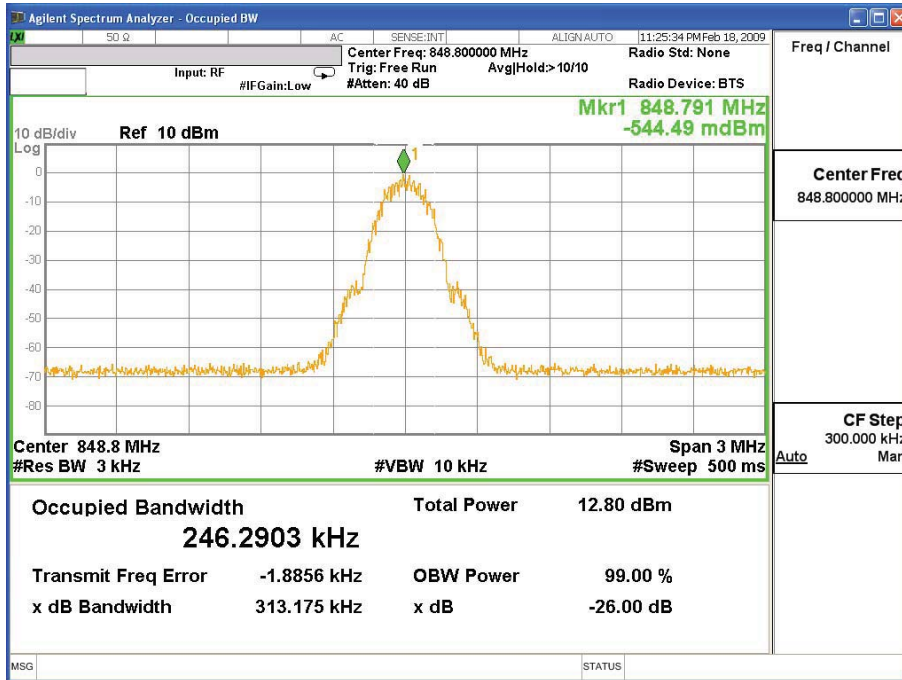

Product	HSUPA PCI Express mini card module		
Test Mode	Occupied Bandwidth		
Date of Test	2009/02/18	Test Site	CTR
Test Condition	PCS1900 GPRS		

PCS1900 GPRS - Packet Switched (PCS Mode CH 512)

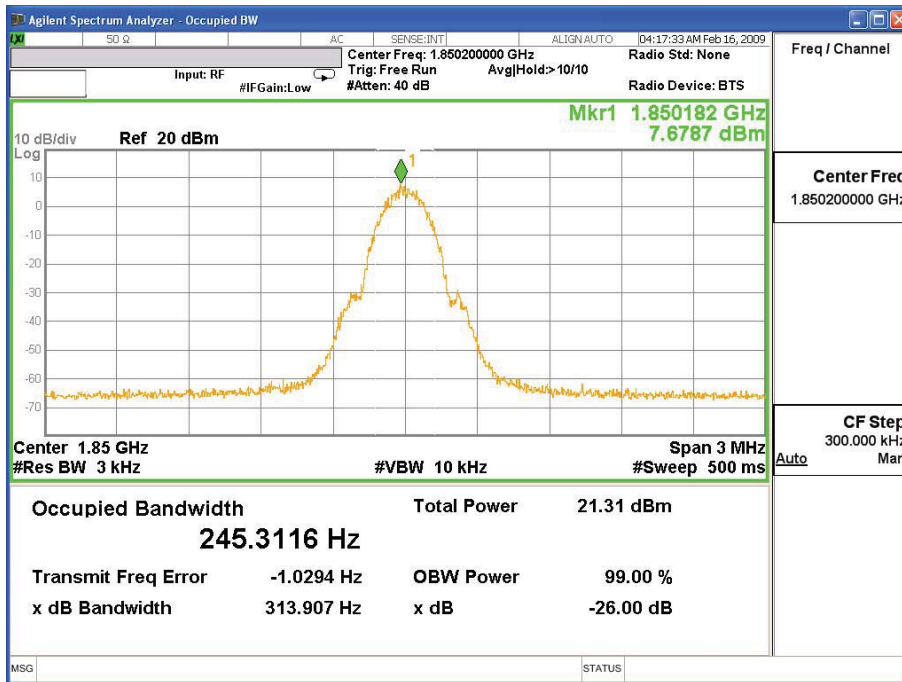

PCS1900 GPRS - Packet Switched (PCS Mode CH661)

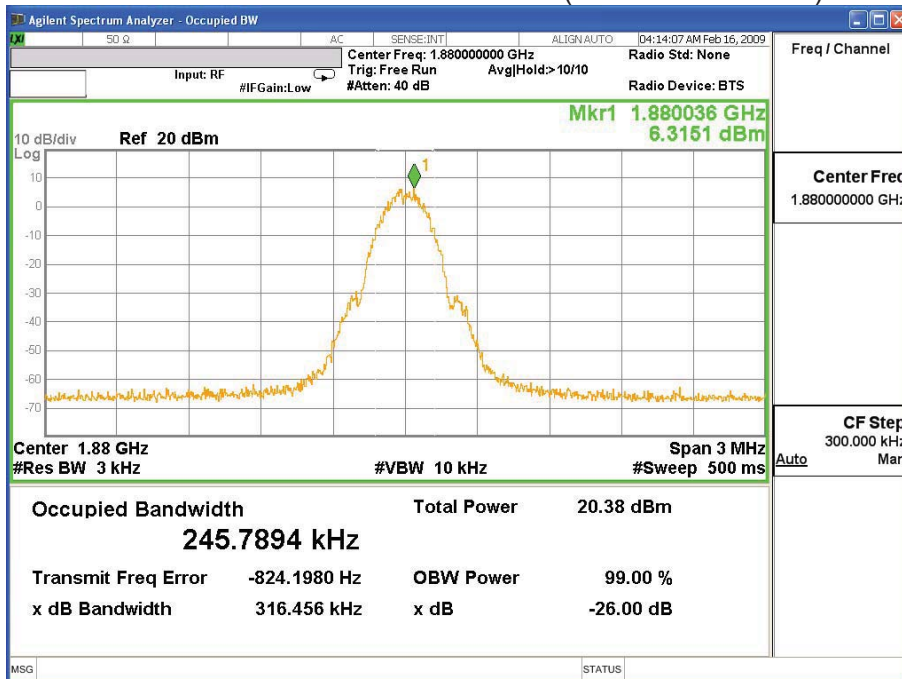

Product	HSUPA PCI Express mini card module		
Test Mode	Occupied Bandwidth		
Date of Test	2009/02/18	Test Site	CTR
Test Condition	PCS1900 GPRS		

PCS1900 GPRS - Packet Switched (PCS Mode CH 810)

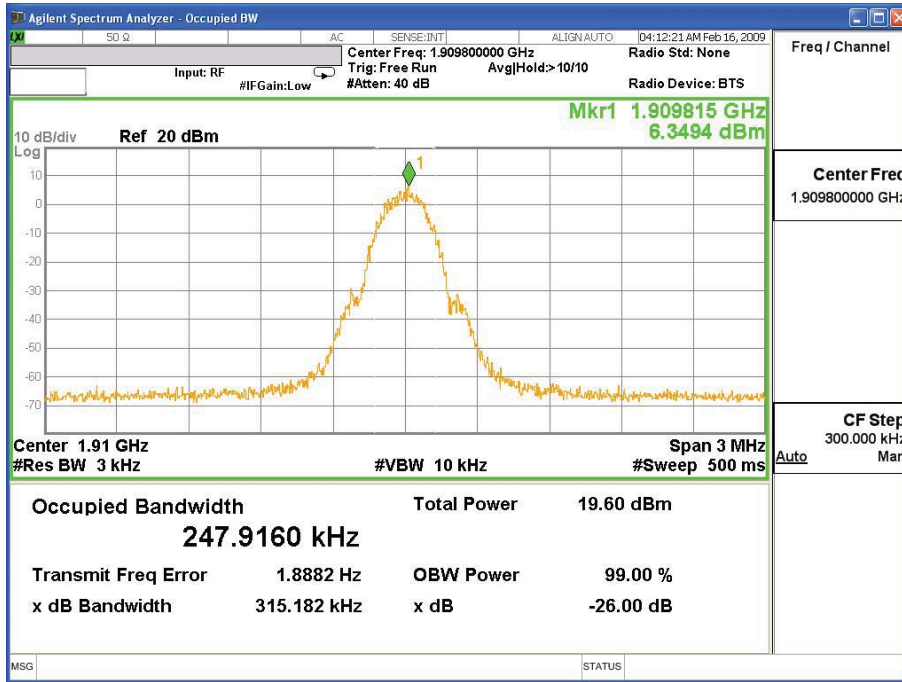

Product	HSUPA PCI Express mini card module		
Test Mode	Occupied Bandwidth		
Date of Test	2009/02/18	Test Site	CTR
Test Condition	GSM 850 EGPRS		

GSM 850 EGPRS - Packet Switched (GSM Mode CH 128)

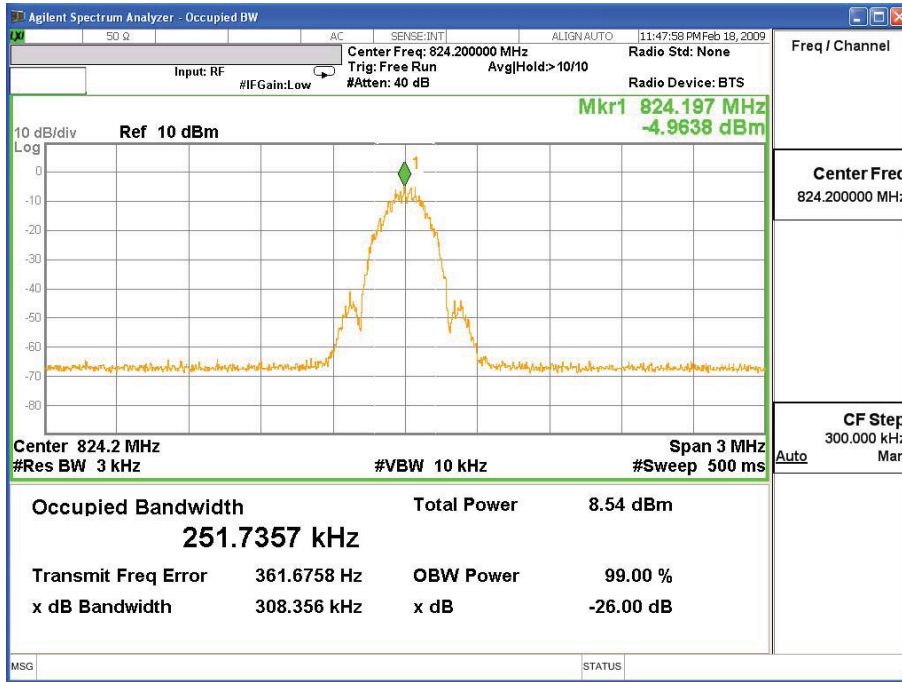

GSM 850 EGPRS - Packet Switched (GSM Mode CH189)

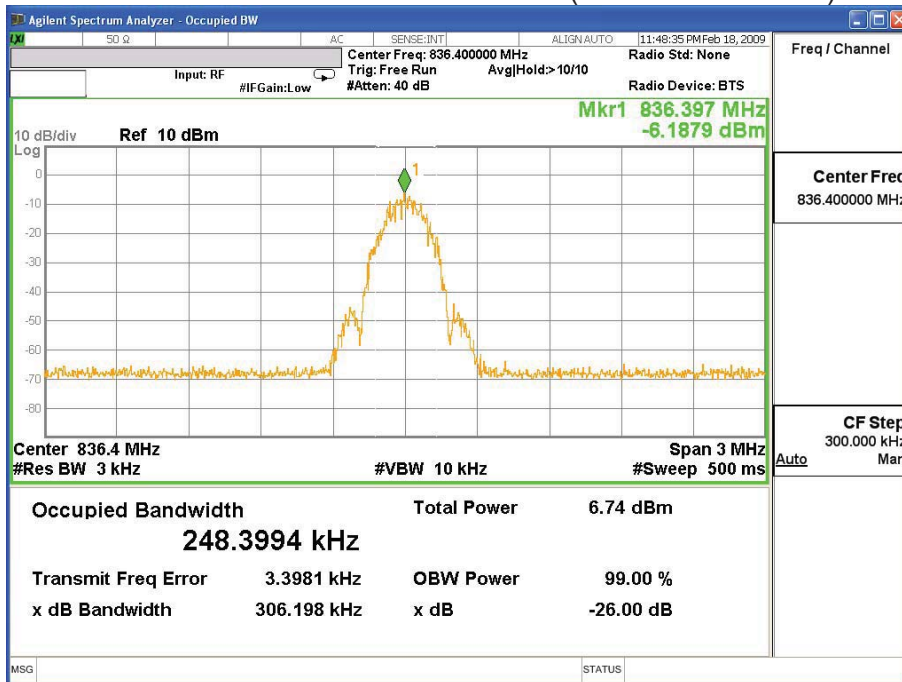

Product	HSUPA PCI Express mini card module		
Test Mode	Occupied Bandwidth		
Date of Test	2009/02/18	Test Site	CTR
Test Condition	GSM 850 EGPRS		

GSM 850 EGPRS - Packet Switched (GSM Mode CH 251)

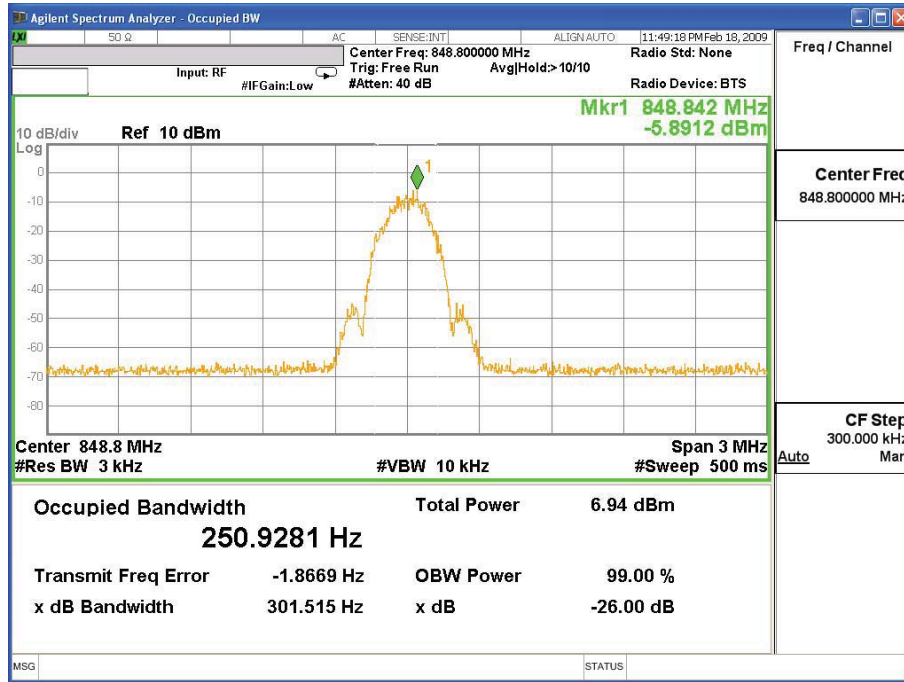

Product	HSUPA PCI Express mini card module		
Test Mode	Occupied Bandwidth		
Date of Test	2009/02/18	Test Site	CTR
Test Condition	PCS1900 EGPRS		

PCS1900 EGPRS - Packet Switched (PCS Mode CH 512)

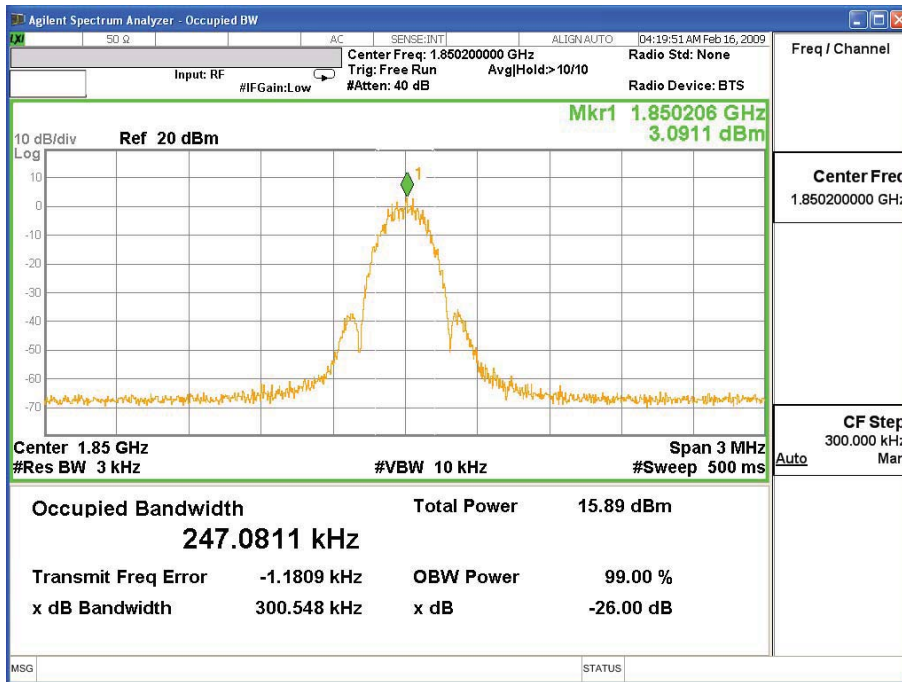

PCS1900 EGPRS - Packet Switched (PCS Mode CH661)

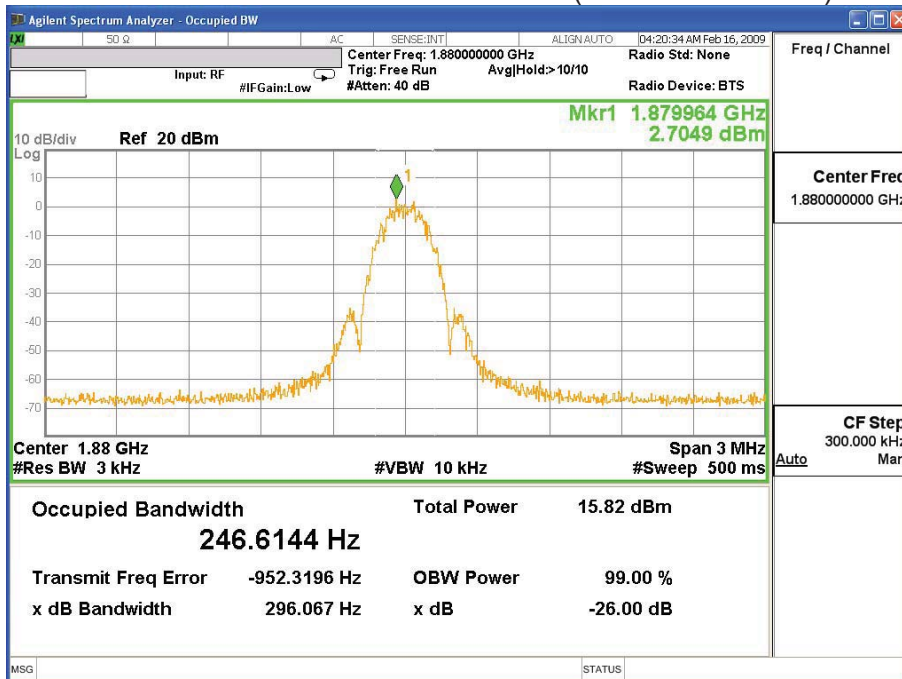

Product	HSUPA PCI Express mini card module		
Test Mode	Occupied Bandwidth		
Date of Test	2009/02/18	Test Site	CTR
Test Condition	PCS1900 EGPRS		

PCS1900 EGPRS - Packet Switched (PCS Mode CH 810)

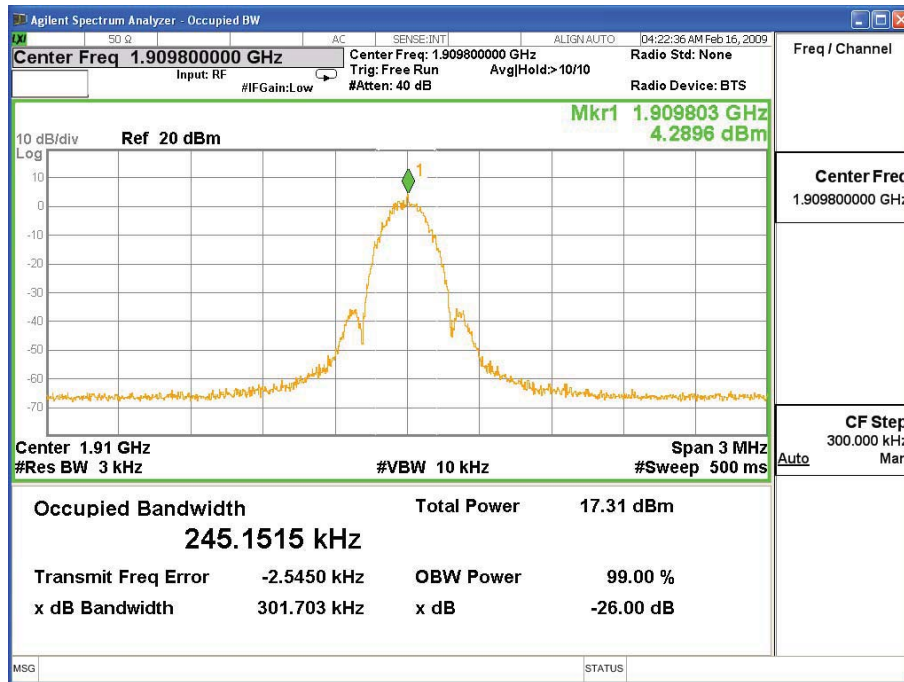

Product	HSUPA PCI Express mini card module		
Test Mode	Occupied Bandwidth		
Date of Test	2009/02/18	Test Site	CTR
Test Condition	WCDMA BAND V		

WCDMA BAND V - Packet Switched (WCDMA Mode CH 4132)

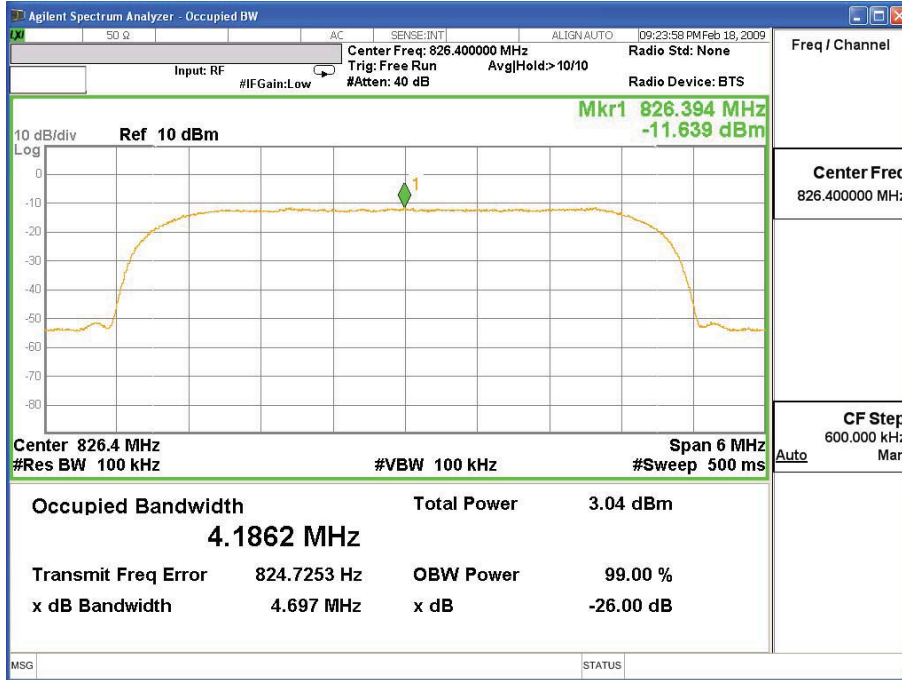

WCDMA BAND V - Packet Switched (WCDMA Mode CH 4183)

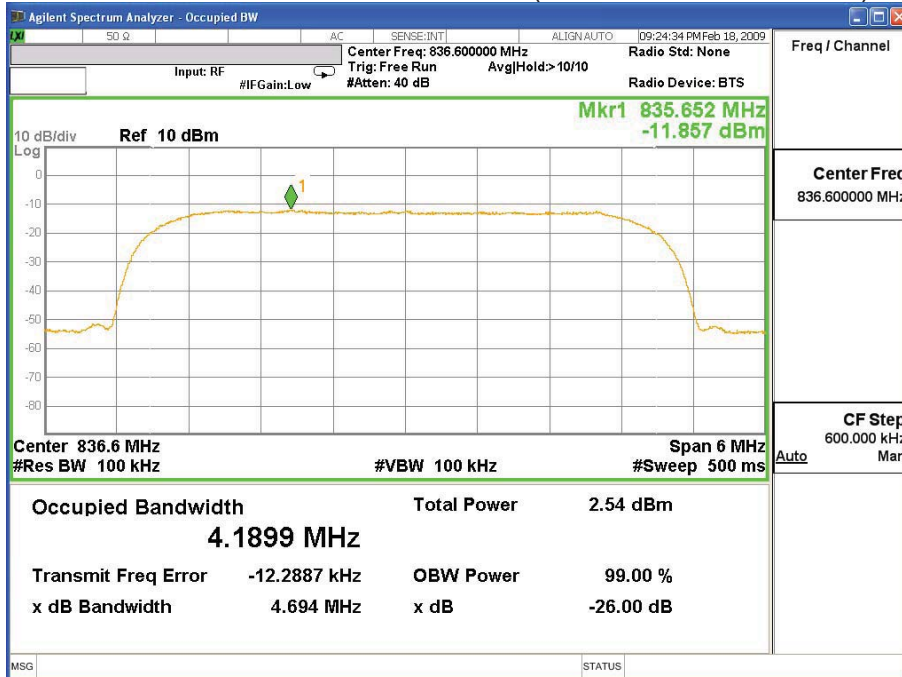

Product	HSUPA PCI Express mini card module		
Test Mode	Occupied Bandwidth		
Date of Test	2009/02/18	Test Site	CTR
Test Condition	WCDMA BAND V		

WCDMA BAND V - Packet Switched (WCDMA Mode CH 4233)

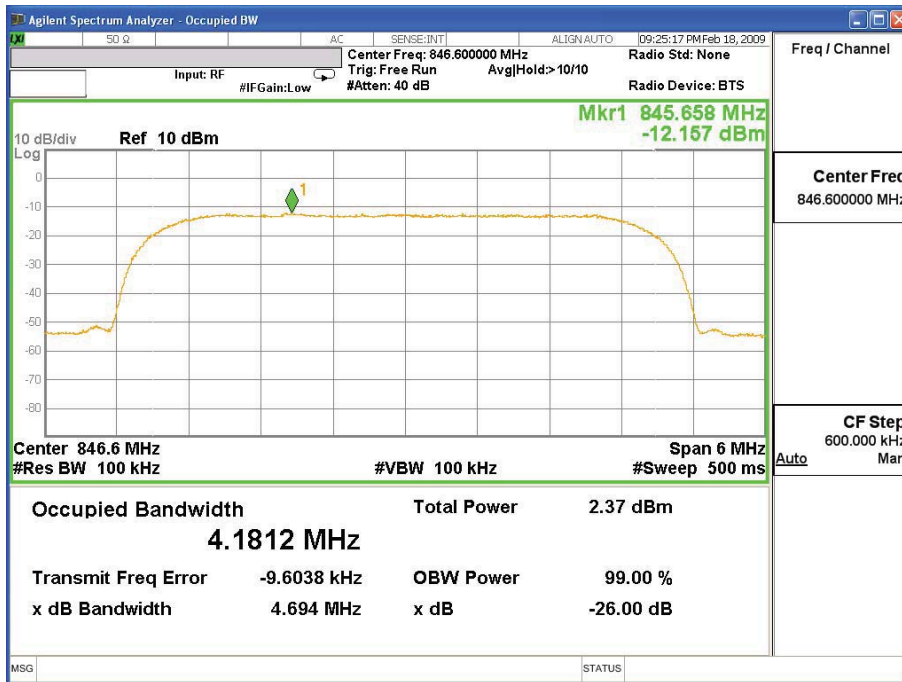

Product	HSUPA PCI Express mini card module		
Test Mode	Occupied Bandwidth		
Date of Test	2009/02/18	Test Site	CTR
Test Condition	WCDMA BAND V HSDPA		

WCDMA BAND V HSDPA - Packet Switched (HSDPA Mode CH 4132)

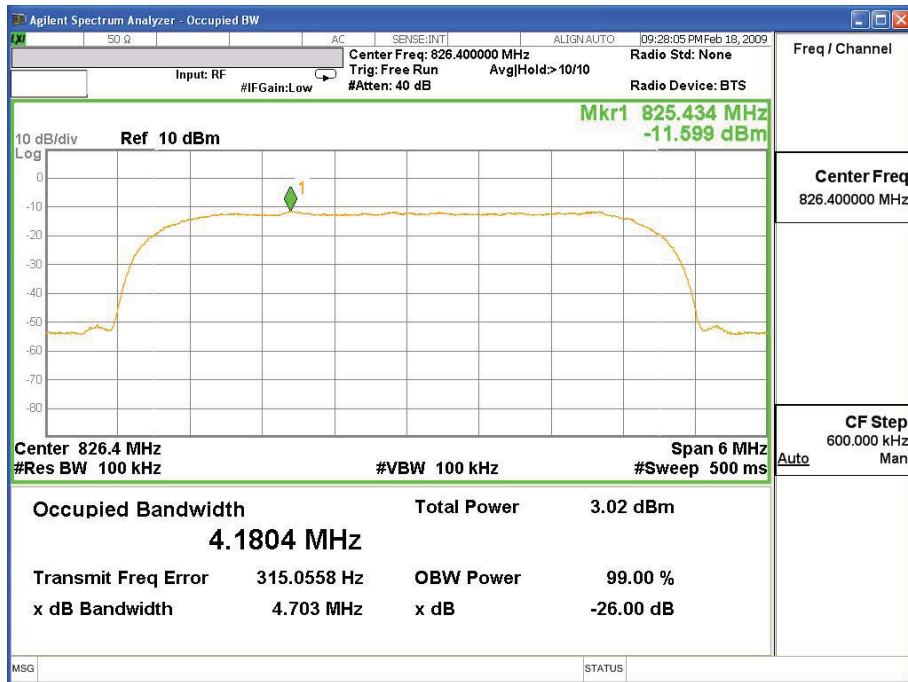

WCDMA BAND V HSDPA - Packet Switched (HSDPA Mode CH 4183)

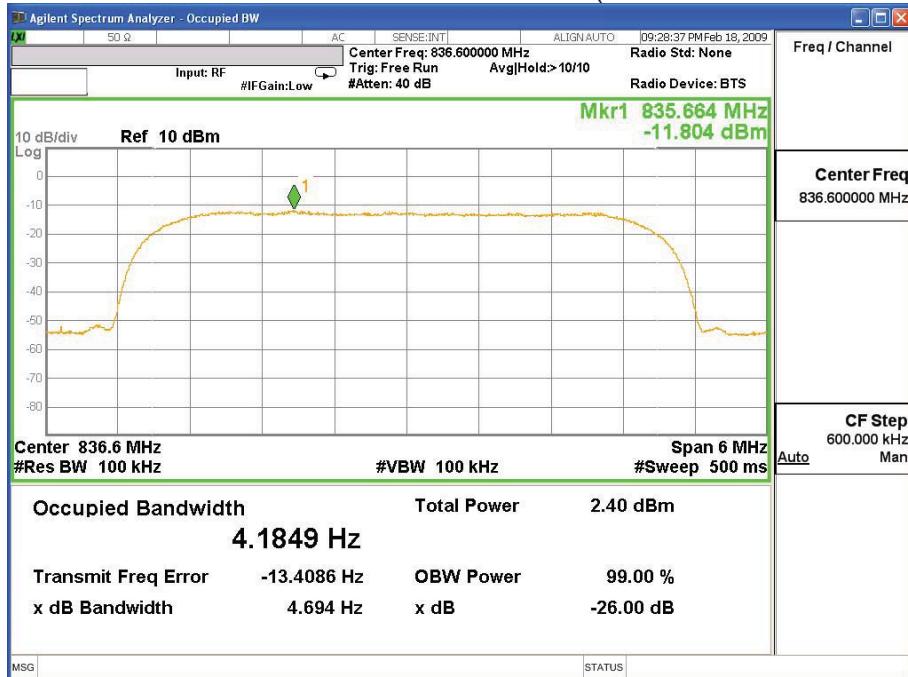

Product	HSUPA PCI Express mini card module		
Test Mode	Occupied Bandwidth		
Date of Test	2009/02/18	Test Site	CTR
Test Condition	WCDMA BAND V HSDPA		

WCDMA BAND V HSDPA - Packet Switched (HSDPA Mode CH 4233)

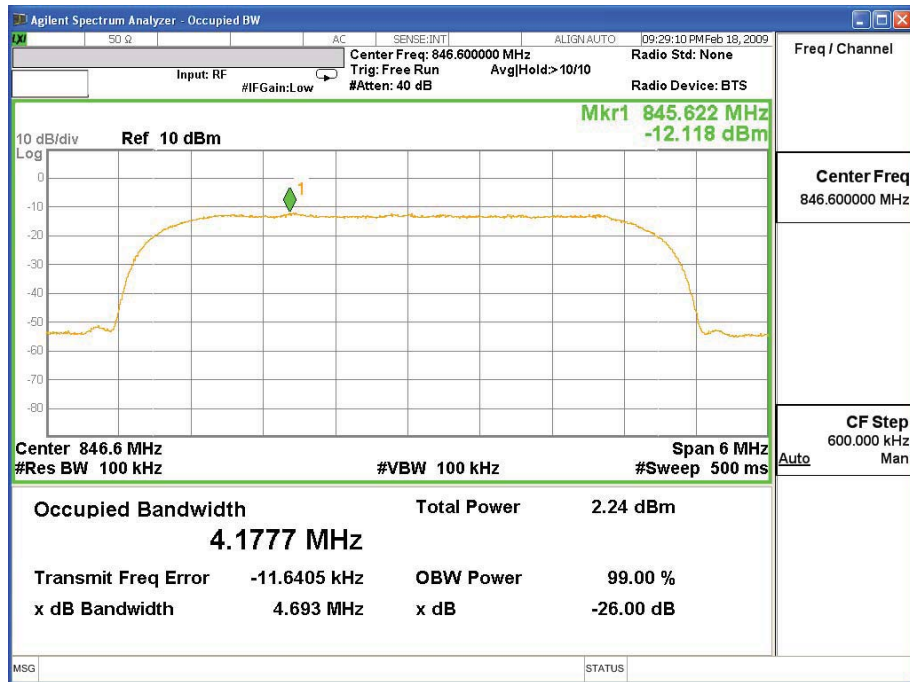

Product	HSUPA PCI Express mini card module		
Test Mode	Occupied Bandwidth		
Date of Test	2009/02/18	Test Site	CTR
Test Condition	WCDMA BAND V HSUPA		

WCDMA BAND V HSUPA - Packet Switched (HSUPA Mode CH 4132)

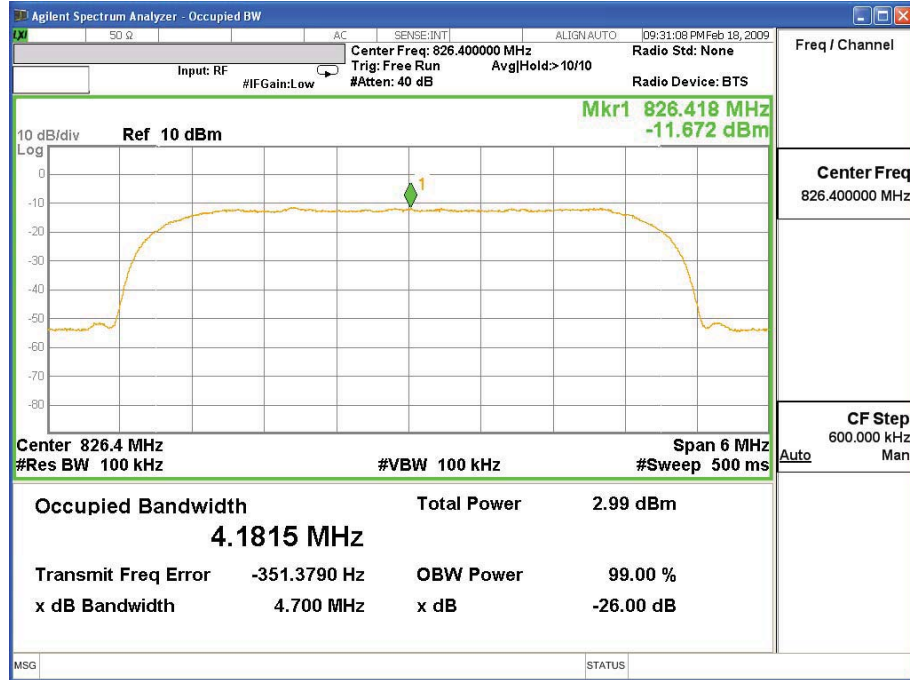

WCDMA BAND V HSUPA - Packet Switched (HSUPA Mode CH 4183)

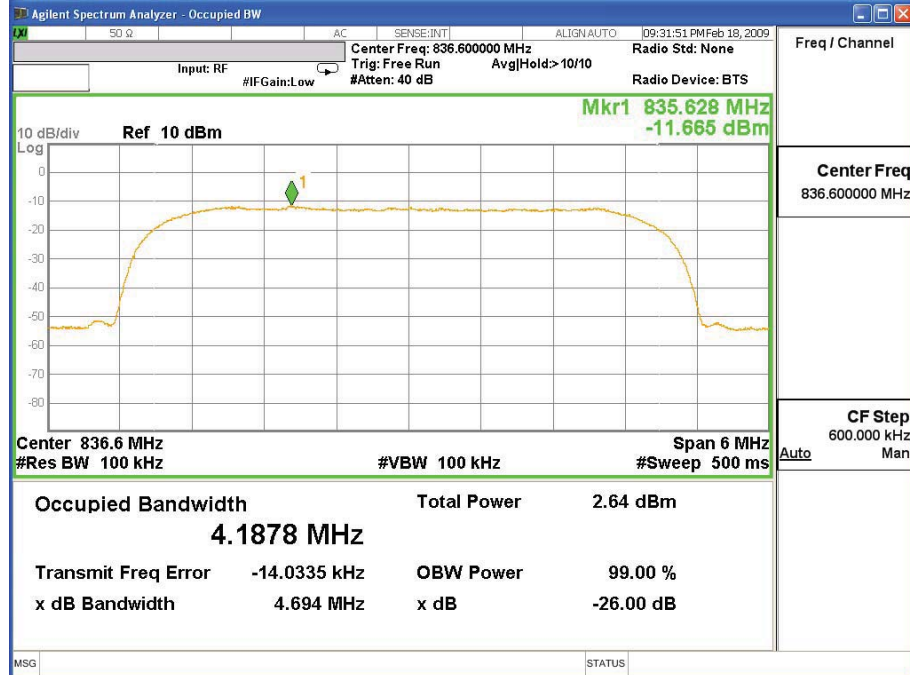

Product	HSUPA PCI Express mini card module		
Test Mode	Occupied Bandwidth		
Date of Test	2009/02/18	Test Site	CTR
Test Condition	WCDMA BAND V HSUPA		

WCDMA BAND V HSUPA - Packet Switched (HSUPA Mode CH 4233)

