

# PWR / GND

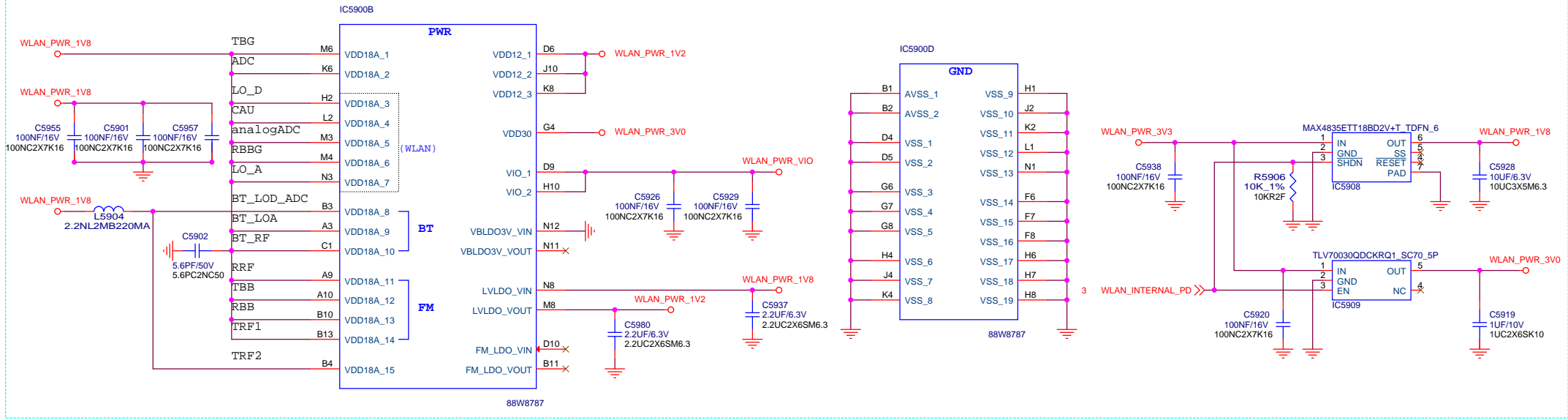

# CONTROL

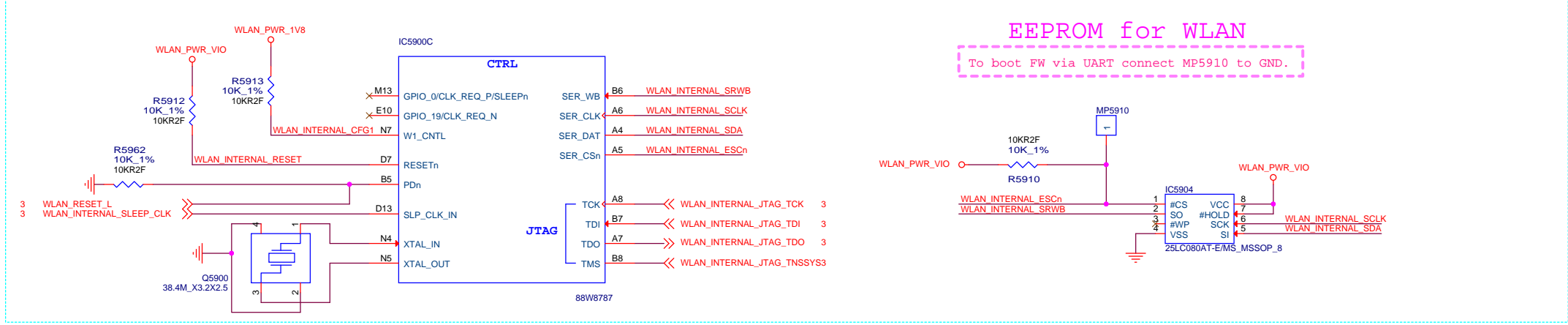

Title		01 POWER / CONTROL	
Size	Document Number	Rev	
Custom		1.2	
Date:	Tuesday, October 29, 2013	Sheet	1 of 5

# BT

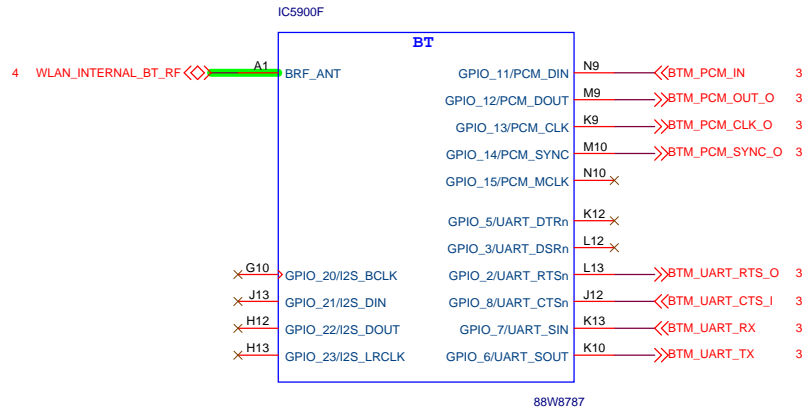

# WLAN

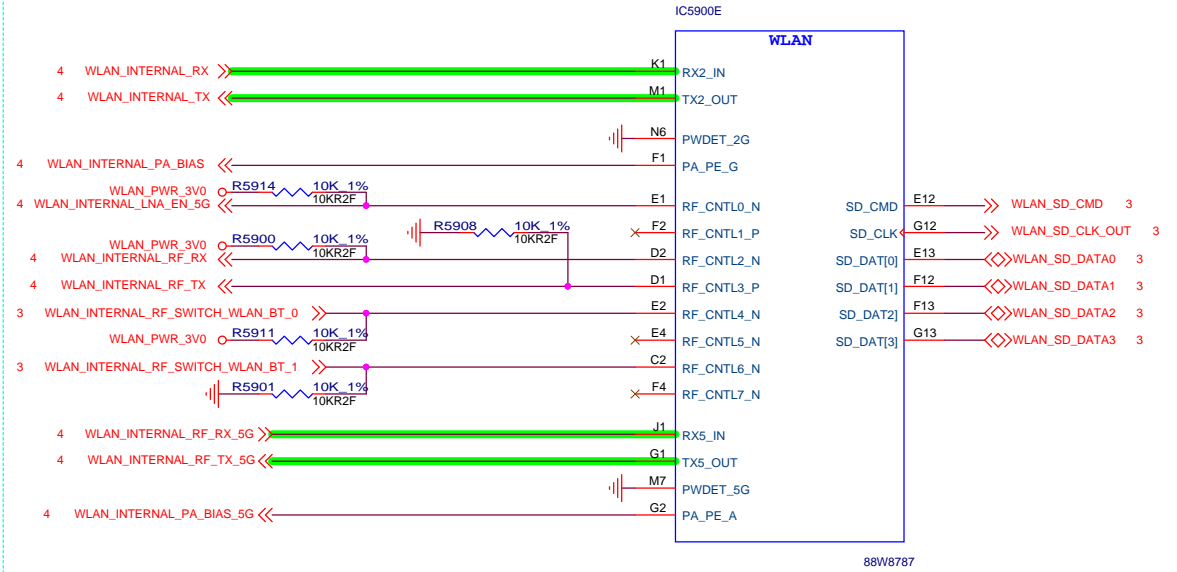

# FM/GPIO

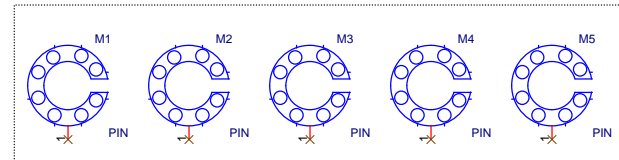
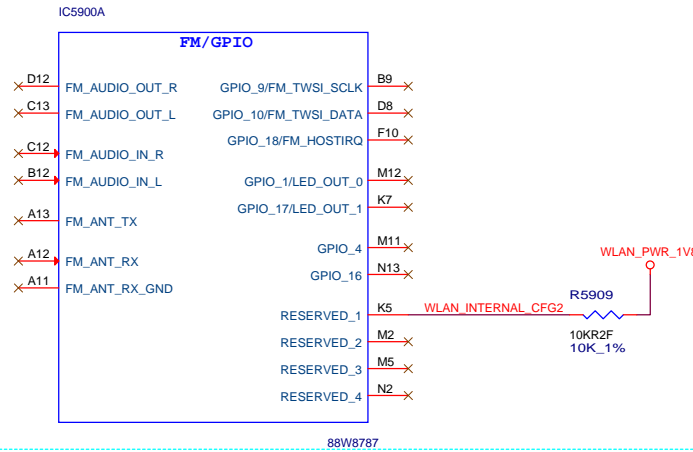

optical position holes

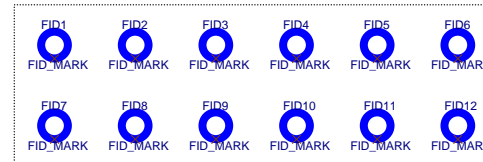

module distinguish points



optical position points

Title			02 WLAN/BT/FM/GPIO
Size	Document Number		Rev
Custom			1.2
Date:	Tuesday, October 29, 2013	Sheet	2 of 5

# Boundary Scan Chain

## WLAN RF

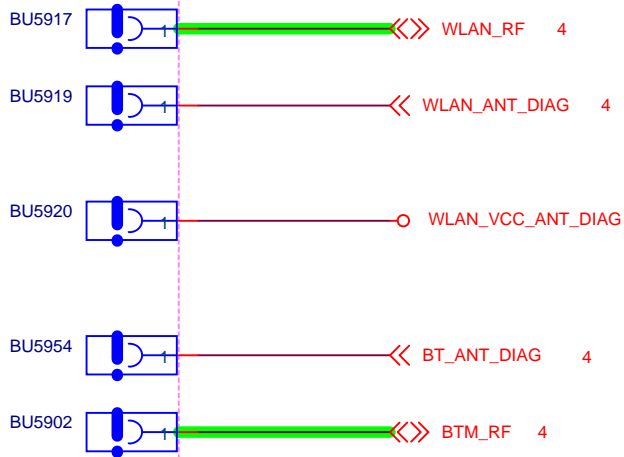

## BLUETOOTH RF

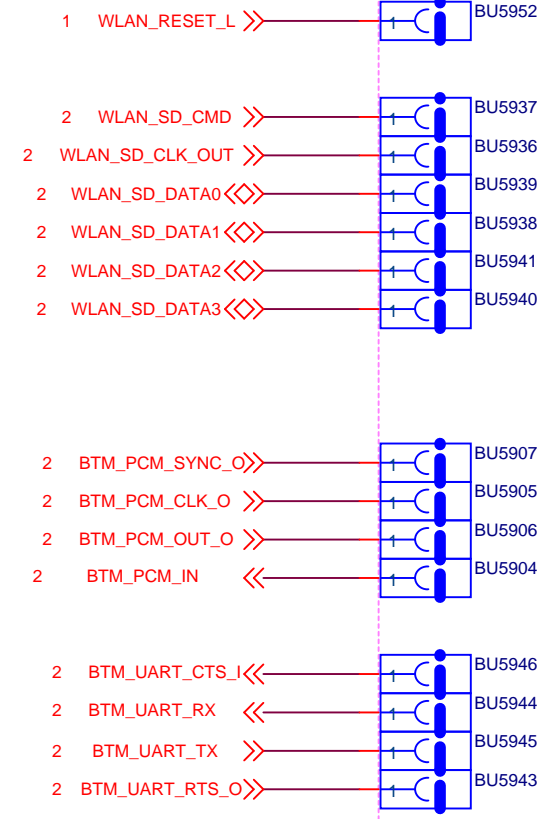
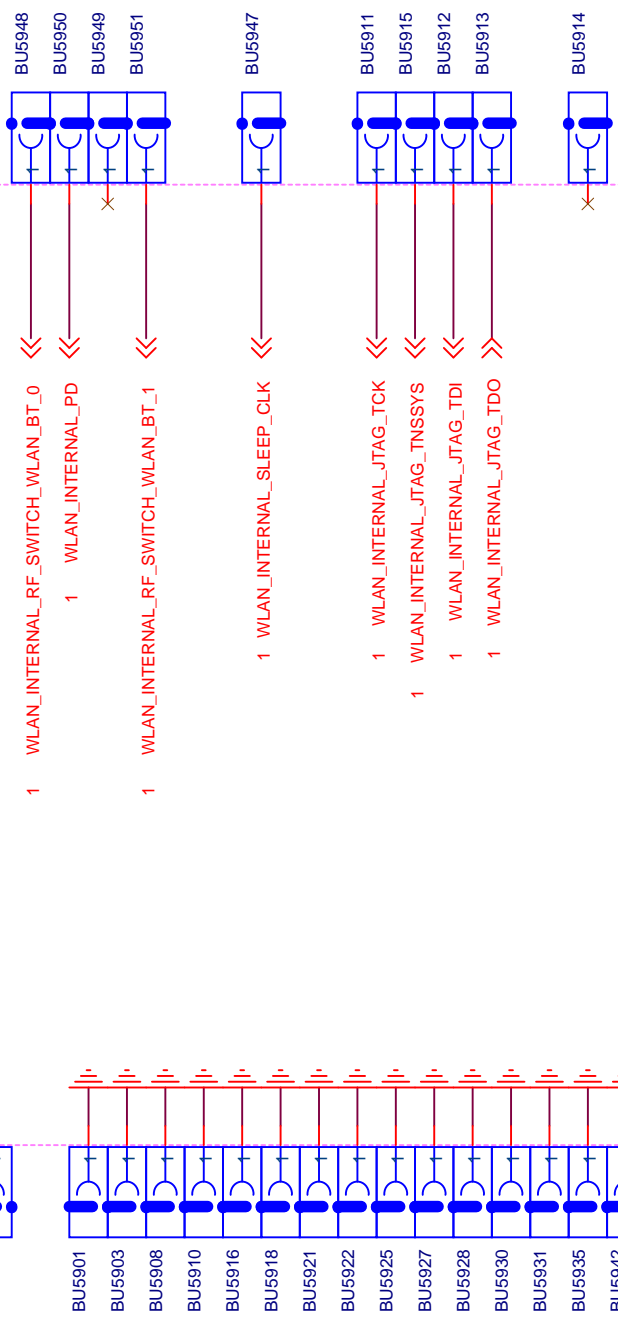
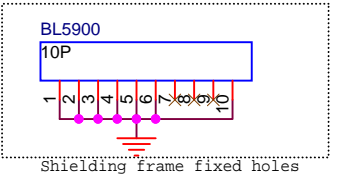
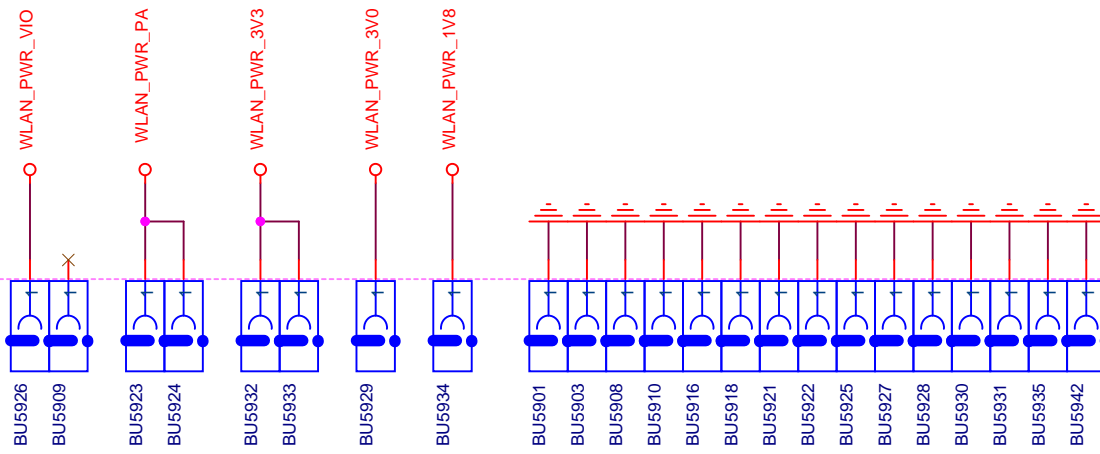

Title		
03 CONNECTION_PADS		
Size	Document Number	Rev
A4		1.2
Date:	Tuesday, October 29, 2013	Sheet 3 of 5



Version 1.0

It's the first released.

Version 1.1

Modified WiFi / BT matching

For 11n Rx sen.:

- (1). L5906: 3.9nH --> 4.7nH
- (2). Add C5948

For 11n EVM:

- (1). L5905: 3.9nH --> 10pF
- (2). C5907: 2.2pF --> 2pF

For BT performance improvement

- (1). Add C5921
- (2). L5909: 3.9nH --> 2.7nH

Remove BR5905 & BR5906

Version 1.2

Solve Band-edge issue

- (1). R5904: 150 ohm --> 31.6 ohm
- (2). R5905: 200 ohm --> 0 ohm
- (3). R5904: 33 ohm --> 52.3 ohm

Title		
05 REVISION HISTORY		
Size	Document Number	Rev
B		1.2
Date:	Tuesday, October 29, 2013	Sheet 5 of 5