



Registration
No.910917

TEST REPORT

Report No.: SRTC2016-9003(F)-0001
Product Name: GSM/GPRS/EGPRS/UMTS/LTE Digital Mobile
Phone with Bluetooth and WiFi
Model Name: Philips Xenium V787
Applicant: Shenzhen Sang Fei Consumer Communications
Co.,Ltd.
Manufacturer: Shenzhen Sang Fei Consumer Communications
Co.,Ltd.
Specification: FCC Part15B (Certification)
(2015 edition)
FCC ID: VQRCTV787

The State Radio_monitoring_center Testing Center (SRTC)

No.80 Beilishi Road Xicheng District Beijing, China

Tel: 86-10-57996181 Fax: 86-10-57996288

CONTENTS

1. General information	3
1.1 Notes of the test report	3
1.2 Information about the testing laboratory.....	3
1.3 Applicant's details	3
1.4 Manufacturer's details.....	3
1.5 Application details	4
1.6 Reference specification.....	4
1.7 Information of EUT.....	4
1.7.1 General information.....	4
1.7.2 EUT details	5
1.7.3 Auxiliary equipment details.....	5
2. Test information	6
2.1 Summary of the test results.....	6
2.2 Test result.....	7
2.2.1 Conducted Emissions-FCC Part15.107	7
2.2.2 Radiated Emissions-FCC Part15.109	12
2.3. List of test equipments	17
Appendix	18

1. General information

1.1 Notes of the test report

The test report may only be reproduced or published in full. Reproduction or publication of extracts from the report requires the prior written permission of The State Radio_monitoring_center Testing Center (SRTC).

The test results relate only to individual items of the samples which have been tested.

1.2 Information about the testing laboratory

Company: The State Radio_monitoring_center Testing Center (SRTC)
Address: No.80 Beilishi Road, Xicheng District
City: Beijing
Country or Region: China
Contacted person: Liu Jia
Tel: +86 10 57996181
Fax: +86 10 57996288
Email: liujiaf@srtc.org.cn

1.3 Applicant's details

Company: Shenzhen Sang Fei Consumer Communications Co.,Ltd.
Address: 11 Science & Technology Rd., Shenzhen Hi-tech Industrial Park,
Nanshan District, Shenzhen
City: Shenzhen
Country or Region: P.R.China
Contacted person: linda zhang
Tel: 010-68300097
Fax: 010-68300097
Email: linda.zhang@sangfei.com

1.4 Manufacturer's details

Company: Shenzhen Sang Fei Consumer Communications Co.,Ltd.
Address: 11 Science & Technology Rd., Shenzhen Hi-tech Industrial Park,
Nanshan District, Shenzhen
City: Shenzhen
Country or Region: P.R.China
Contacted person: linda zhang
Tel: 010-68300097
Fax: 010-68300097
Email: linda.zhang@sangfei.com

1.5 Application details

Date of reception of test sample: 21th Feb. 2016

Date of test: 21th Feb. 2016 to 25th Feb. 2016

1.6 Reference specification

FCC Part 15B, 2015 (Certification)

1.7 Information of EUT

1.7.1 General information

Name of EUT	GSM/GPRS/EGPRS/UMTS/LTE Digital Mobile Phone with Bluetooth and WiFi
FCC ID	VQRCTV787
Frequency Range	GSM850:Tx:824~849MHz Rx:869~894MHz WCDMA Band VI: Tx:830 - 840 MHz Rx:875 - 885 MHz PCS1900/WCDMA Band II/ FDD 2:Tx:1850~1910MHz Rx:1930~1990MHz FDD 4: Tx:1710~1755MHz Rx:2110~2155MHz FDD 7: Tx:2500~2570MHz Rx:2620~2690MHz
Rated Output Power	GSM850:32.5dBm PCS1900:29.5dBm WCDMA:22.5 dBm LTE :22.5dBm
Modulation Type	GSM/GPRS:GMSK EDGE:GMSK WCDMA:QPSK LTE :QPSK/16QAM
Emission Designator	GSM/GPRS EDGE WCDMA LTE
Duplex Mode	FDD
Equipment Class	Class B
Duplex Spacing	GSM850/WCDMA Band VI:45MHz PCS1900/WCDMA Band II:80MHz FDD 2: 80MHz FDD 4: 95MHz FDD 7: 120MHz
Antenna Type	Dipole Antenna
Power Supply	Battery or Charger
Rated Power Supply Voltage	3.8V

Extreme Temperature	Lowest: -30°C Highest: +50°C
Extreme Voltage	Minimum: 3.5V Maximum: 4.35V
HW Version	WMCVc
SW Version	Philips_V787_1553_V01_AG_FCC

1.7.2 EUT details

Product Name	Model Name	IMEI
GSM/GPRS/EGPRS/UMTS/LTE Digital Mobile Phone with Bluetooth and WiFi	Philips Xenium V787	866636024833117 866636024833125

1.7.3 Auxiliary equipment details

AE (Auxiliary Equipment) 1#: Charger

Equipment	Charger
Manufacturer	DONGGUAN AOHAI POWER TECHNOLOGY CO., LTD.
Model Number	A88A-50200U-AR1
S/N	---
Input Voltage	100V-240V a.c.
Output Voltage	5.0V d.c.
Frequency	50/60Hz

AE (Auxiliary Equipment) 2#: Battery

Equipment	Battery
Manufacturer	Zhongshan Tianmao Battery Co.
Model Number	AB5000AWML
Capacity	5000mAh
Rated Voltage	3.8V d.c.



AE (Auxiliary Equipment) 3#: Headset

Equipment	Headset
Manufacturer	Dongguan Tian Zhi Industrial Co., Ltd.
Model Number	TJ-101158

2. Test information

2.1 Summary of the test results

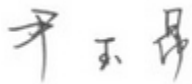
No.	Test case	FCC reference	Verdict
1	Conducted emissions	15.107	Pass
2	Radiated emissions	15.109	Pass

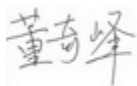
Approved by Mr. Yin Yuang Director of the test department 	Checked By Mr. He Jia Project manager of the test department 
Tested by: Mr. Dong Qifeng Test engineer 	Issued date: 2016.03.07

2.2 Test result

2.2.1 Conducted Emissions-FCC Part15.107

Ambient condition:

Temperature	Relative humidity	Pressure
23.4	43.3%	101.1kPa

Test Setup with laptop:

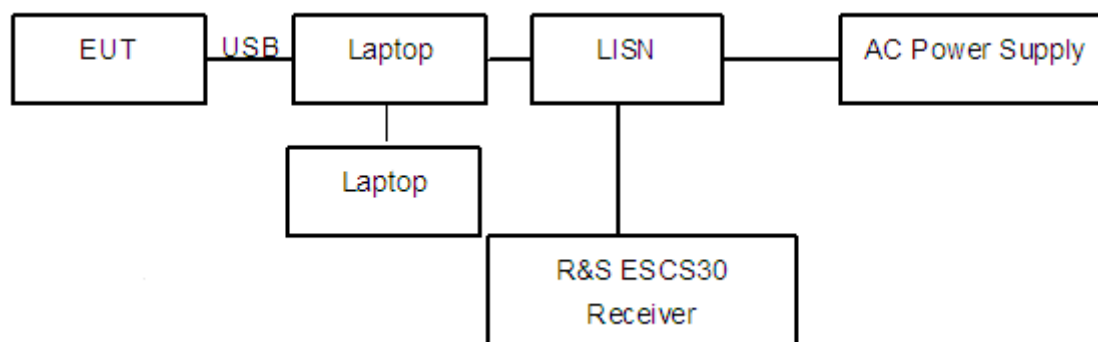

Figure 1

Test Procedure:

The EUT is placed on a non-metallic table 0.8m above the horizontal metal reference ground plane. The accessories of the EUT are connected with the EUT such as headset etc. The EUT was exercised during the testing by data read and write cycles repeated with internal storages connecting with a laptop via the USB cable. The laptop's LAN port is connected with another laptop via cable. And the data transferring between two laptops is maintained.

The AC main power supply of the laptop is connected to LISN and LISN is connected to the reference ground. The test set-up and the test methods are performed according to ANSI C63.4:2014.

Then start the test software ES-K1. Sweep the whole frequency band through the range from 150 KHz to 30 MHz. The measurement should be done for both L line and N line. During pre-test, the receiver uses both peak detector and average detector. And the final test, the receiver uses both average detector and Quasi-peak detector.

The data of cable loss has been calibrated in full testing frequency range before the testing.

Test Setup with charger:

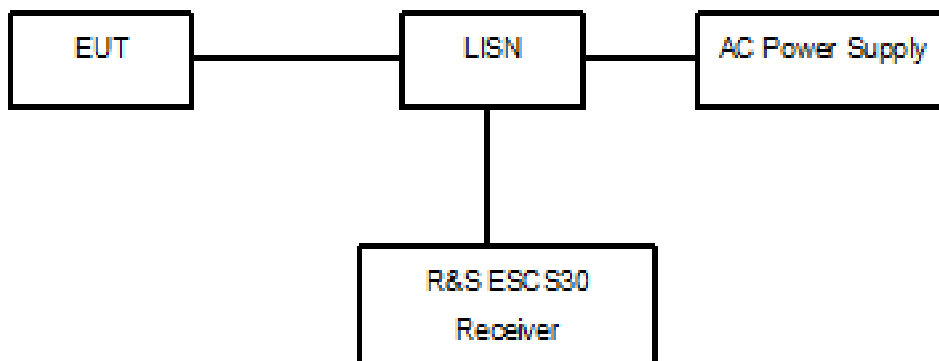

Figure 2

Test Procedure:

The EUT is placed on a non-metallic table 0.8m above the horizontal metal reference ground plane. The EUT is connected with LISN via the charger. The LISN is connected to the reference ground. The accessories of the EUT are connected with the EUT such as headset etc.

The test set-up and the test methods are performed according to ANSI C63.4:2014.

Then start the test software ES-K1. Sweep the whole frequency band through the range from 150 KHz to 30 MHz. The measurement should be done for both L line and N line. During pre-test, the receiver uses both peak detector and average detector. And the final test, the receiver uses both average detector and Quasi-peak detector.

The data of cable loss has been calibrated in full testing frequency range before the testing.

Limit:

Frequency of Emission(MHz)	Limits(dB μ V)	
	Quasi-peak	Average
0.15~0.5	66 to 56*	56 to 46*
0.5~5	56	46
5~30	60	50

Note: * Decreases with the logarithm of the frequency

Test result:

Noise Level of the Measuring Instrument

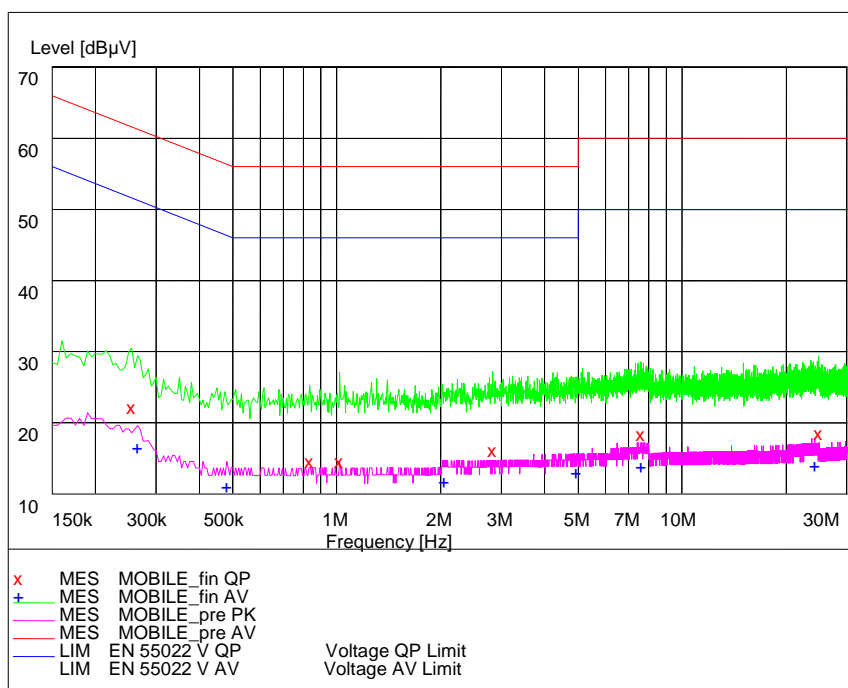

Pic1. Conducted emission L and N Line

EUT+Laptop:

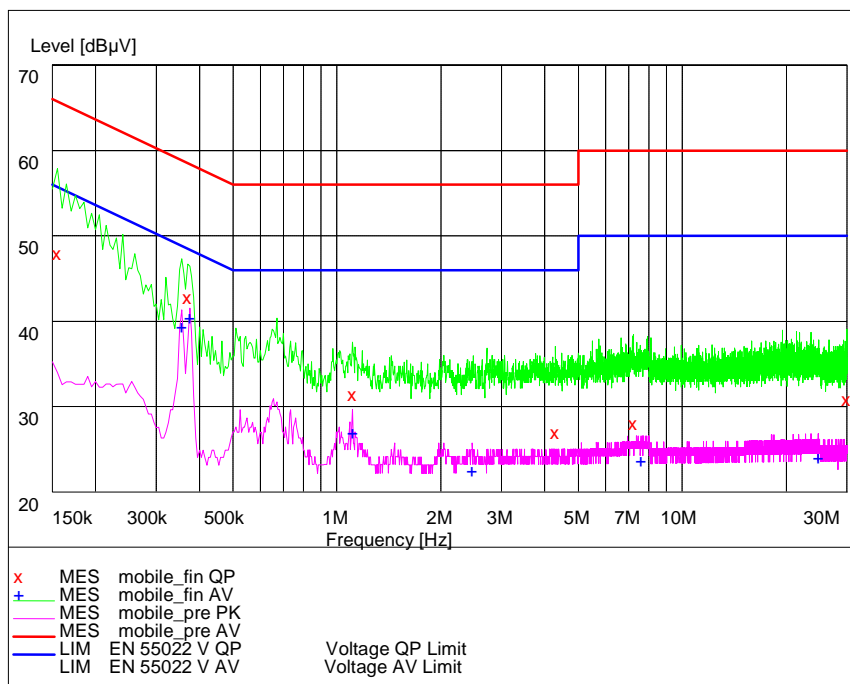

Pic2. Conducted emission L +N Line

MEASUREMENT RESULT: "MOBILE_fin QP"

Frequency	Level	Transd	Limit	Margin	Line	PE
MHz	dBµV	dB	dBµV	dB		
0.155000	49.40	29.5	66	16.3	L	---
0.370000	44.20	29.6	59	14.3	L	---
1.110000	32.80	29.7	56	23.2	N	---
4.295000	28.30	29.8	56	27.7	L	---
7.225000	29.40	29.8	60	30.6	N	---
29.980000	32.20	30.1	60	27.8	L	---

MEASUREMENT RESULT: "MOBILE_fin AV"

Frequency	Level	Transd	Limit	Margin	Line	PE
MHz	dBµV	dB	dBµV	dB		
0.355000	40.70	29.6	49	8.2	L	---
0.375000	41.80	29.6	48	6.6	L	---
1.110000	28.40	29.7	46	17.6	L	---
2.465000	23.90	29.7	46	22.1	L	---
7.600000	25.10	29.9	50	24.9	N	---
24.810000	25.40	30.1	50	24.6	L	---

EUT+Charger:

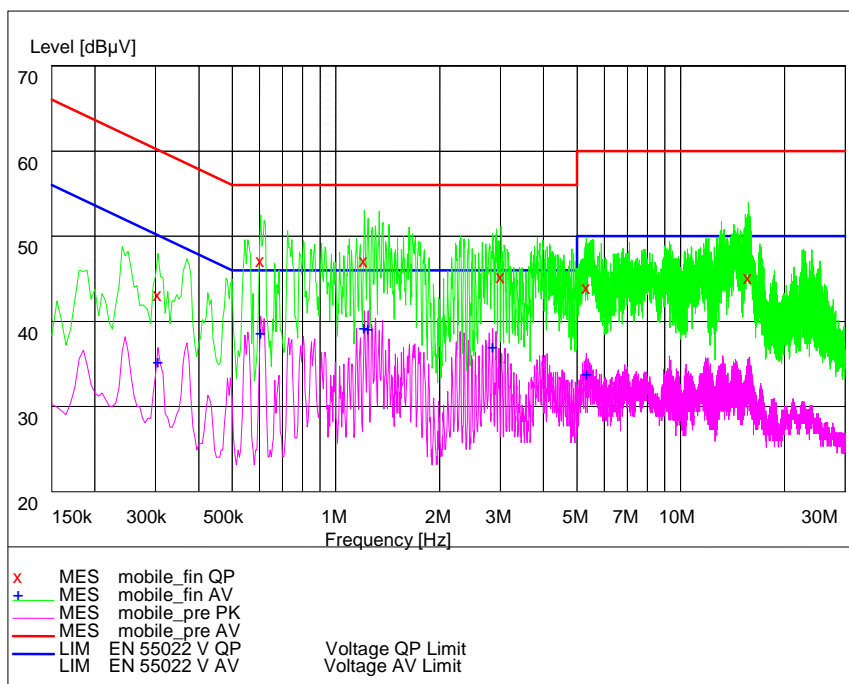

Pic4. Conducted emission L+N Line

MEASUREMENT RESULT: "MOBILE_fin QP"

Frequency	Level	Transd	Limit	Margin	Line	PE
MHz	dBµV	dB	dBµV	dB		
0.305000	44.50	29.6	60	15.6	L	---
0.605000	48.60	29.7	56	7.4	L	---
1.210000	48.60	29.7	56	7.4	L	---
3.015000	46.70	29.7	56	9.3	L	---
5.325000	45.30	29.8	60	14.7	N	---
15.710000	46.50	30.0	60	13.5	L	---

MEASUREMENT RESULT: "MOBILE_fin AV"

Frequency	Level	Transd	Limit	Margin	Line	PE
MHz	dBµV	dB	dBµV	dB		
0.305000	36.70	29.6	50	13.4	L	---
0.605000	40.10	29.7	46	5.9	L	---
1.210000	40.60	29.7	46	5.4	L	---
1.240000	40.50	29.7	46	5.5	L	---
2.850000	38.40	29.7	46	7.6	N	---
5.325000	35.40	29.8	50	14.6	N	---

2.2.2 Radiated Emissions-FCC Part15.109

Ambient condition:

Temperature	Relative humidity	Pressure
23.2°C	42.1%	100.9kPa

Test Setup:

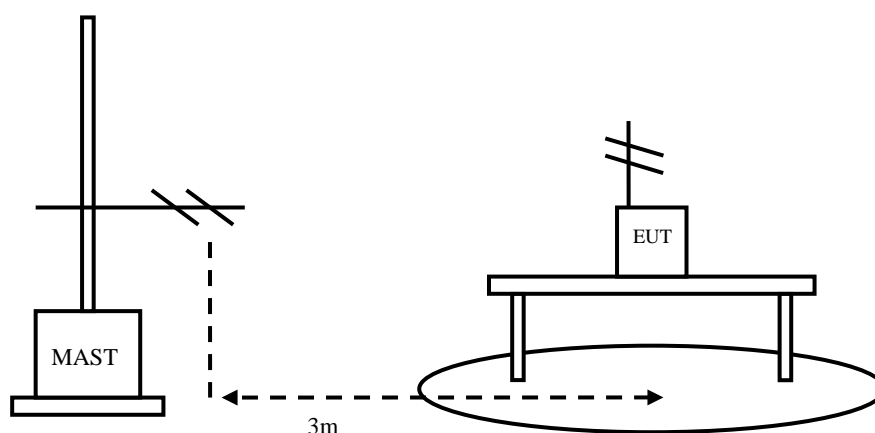

Figure 3

Test Procedure:

EUT+Laptop:

The EUT should be placed on a non-metallic table 80cm above the ground plane. The receive antennas shall be moved from 1 to 4 meters. The distance between EUT and receive antenna should be 3 meters.

The accessories of the EUT are connected with the EUT such as headset etc. The EUT was exercised during the testing by data read and write cycles repeated with internal storages connecting with a laptop via the USB cable. The laptop's LAN port is connected with another laptop via cable. And the data transferring between two laptops is maintained. The test set-up and the test methods are performed according to ANSI C63.4:2014

Then start the test software ES-K1. Sweep the whole frequency band through the range from 30MHz to 1GHz, using receive log period antenna HL562.

During the test, the height of receive antenna shall be moved from 1 to 4 meters, and the antenna shall be performed under horizontal and vertical polarization. The turn table shall be rotated from 0 to 360 degrees for detecting the maximum of

radiated spurious signal level. The measurements shall be repeated with orthogonal polarization of the test antenna. The EUT is laid in two modes as follow:
1. put the EUT in horizontal direction; 2. put the EUT in vertical direction.

The data of cable loss and antenna factor have been calibrated in full testing frequency range before the testing.

EUT+Charger:

The EUT should be placed on a non-metallic table 80cm above the ground plane. The receive antennas shall be moved from 1 to 4 meters. The distance between EUT and receive antenna should be 3 meters.

The EUT should work in idle mode. The accessories of the EUT are connected with the EUT such as headset etc. The test set-up and the test methods are performed according to ANSI C63.4:2014.

Then start the test software ES-K1. Sweep the whole frequency band through the range from 30MHz to 1GHz, using receive log period antenna HL562.

During the test, the height of receive antenna shall be moved from 1 to 4 meters, and the antenna shall be performed under horizontal and vertical polarization. The turn table shall be rotated from 0 to 360 degrees for detecting the maximum of radiated spurious signal level. The measurements shall be repeated with orthogonal polarization of the test antenna. The EUT is laid in two modes as follow:
1. put the EUT in horizontal direction; 2. put the EUT in vertical direction.

The data of cable loss and antenna factor have been calibrated in full testing frequency range before the testing.

A “reference path loss” is established and the A_{Rpl} is the attenuation of “reference path loss”, and including the gain of receive antenna, the gain of the preamplifier, the cable loss.

The measurement results are obtained as described below:

$$\text{Result} = P_{\text{mea}} + A_{Rpl}$$

Limit:

Frequency of Emission(MHz)	Limits	
	Detector	Unit (dB μ V/m)
30~88	Quasi-peak	40
88~216	Quasi-peak	43.5
216~960	Quasi-peak	46
960~1000	Quasi-peak	54
1000~5th harmonic of the highest frequency or 40GHz, whichever is lower	Average	54
	Peak	74

Test result:
EUT+Laptop

Frequency(MHz)	Result(dBuV/m)	ARpl (dB)	Pmea (dBuV/m)	Polarity
30.42	27.98	20.8	7.18	Vertical
39.39	23.38	15.9	7.48	Vertical
41.64	25.45	14.9	10.55	Vertical
180.96	29.68	10.9	18.78	Vertical
215.43	26.03	12.0	14.03	Vertical
431.86	28.54	19.5	9.04	Vertical

EUT+Charger

Frequency(MHz)	Result(dBuV/m)	ARpl (dB)	Pmea (dBuV/m)	Polarity
31.82	18.20	20.1	-1.9	Vertical
76.01	16.60	8.8	7.8	Vertical
87.93	22.20	10.8	11.4	Vertical
95.51	31.40	11.4	20	Vertical
101.60	25.40	12.2	13.2	Vertical
108.81	18.80	12.5	6.3	Vertical

EUT+Laptop:

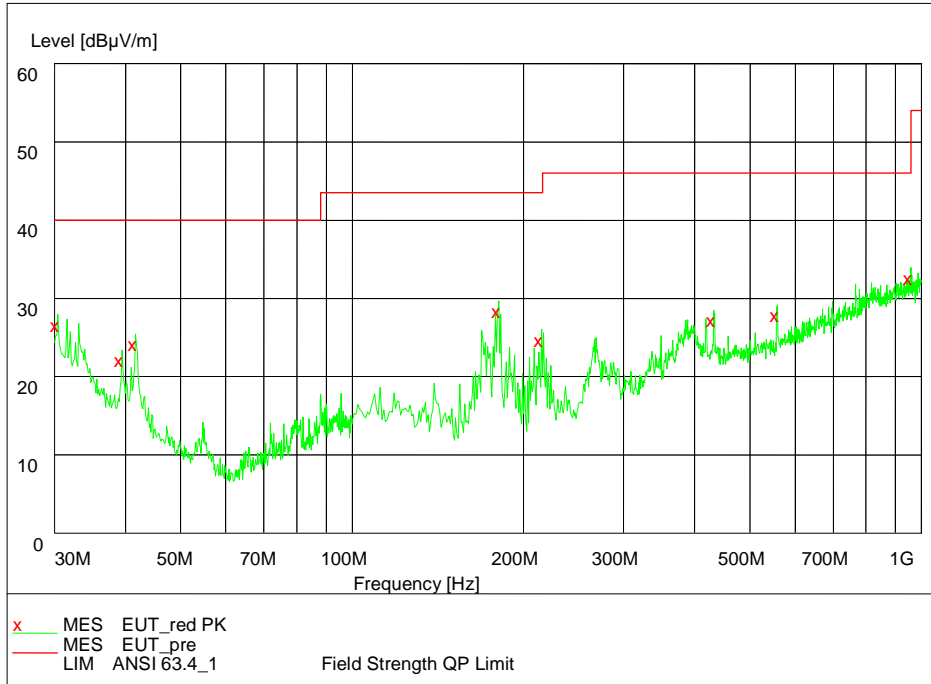

Pic6. Radiated emission (30MHz – 1GHz)

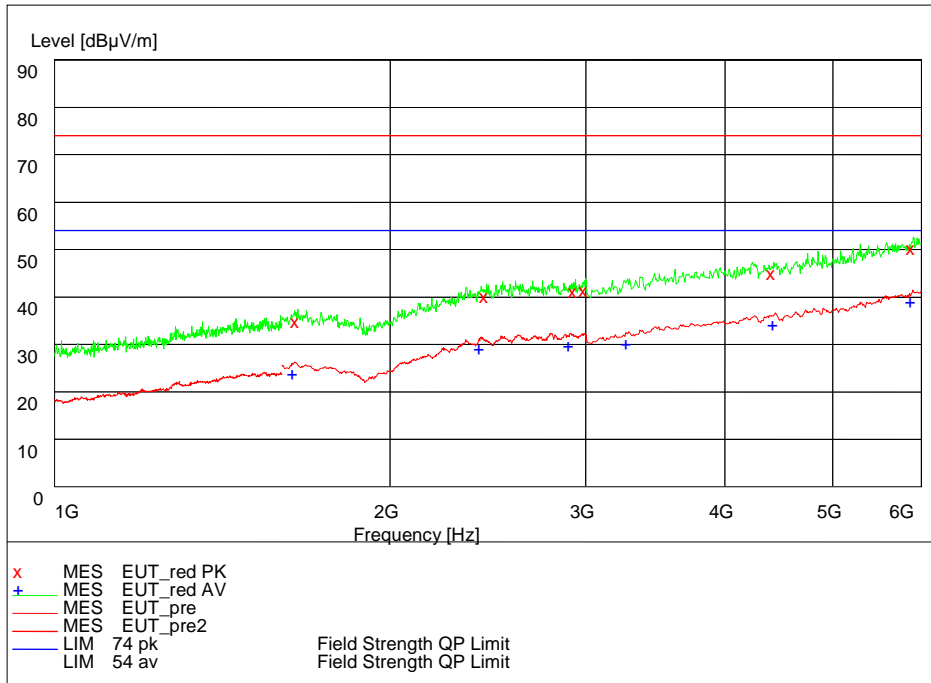

Pic7. Radiated emission (1GHz – 6GHz)

EUT+Charger::

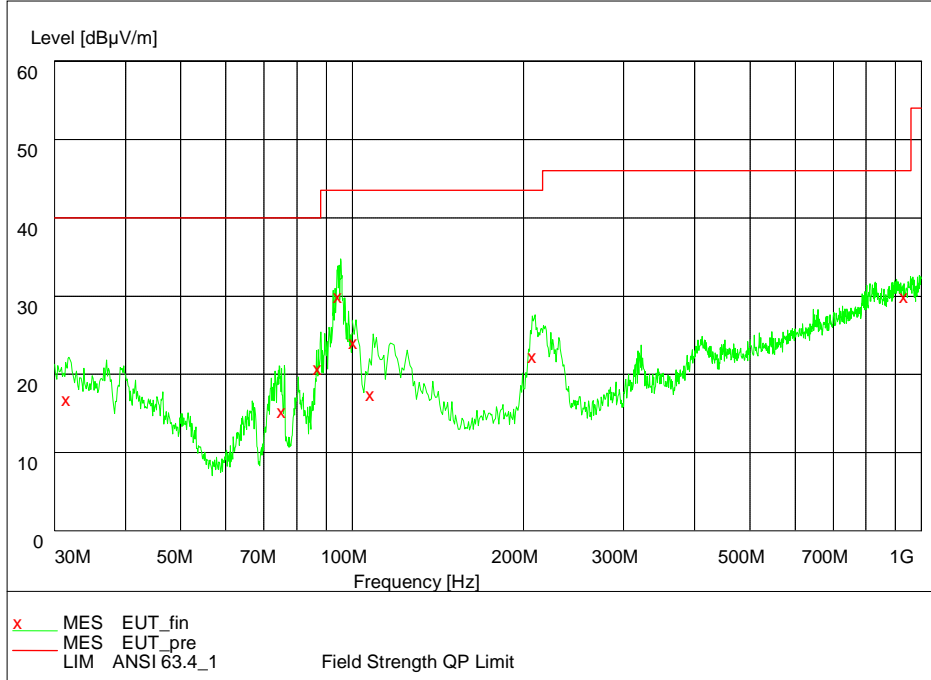

Pic8. Radiated emission (30MHz – 1GHz)

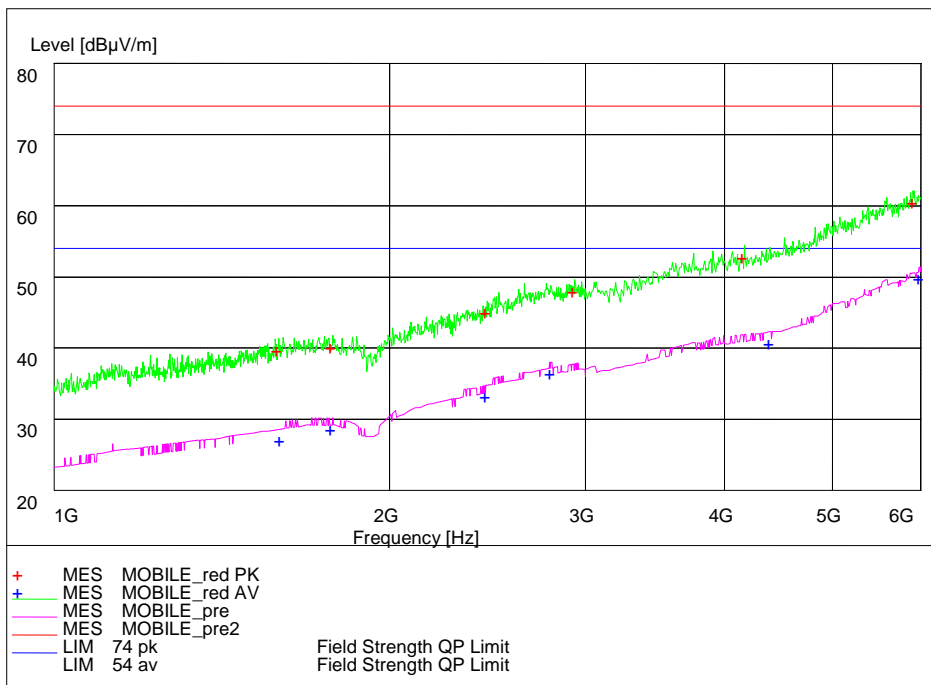

Pic9. Radiated emission (1GHz – 6GHz)

2.3. List of test equipments

No.	Name/Model	Manufacturer	S/N	Calibration Due Date
1	23.18m×16.88m×9.60m Semi-Anechoic Chamber	FRANKONIA	-----	20 th Aug. 2016
2	ESI 40 EMI test receiver	R&S	100015	20 th Aug. 2016
3	E5515C(8960) Mobile Station Tester	Agilent	GB44050904	20 th Aug. 2016
4	9.080m×5.255m×3.525m Shielding room	FRANKONIA	-----	20 th Aug. 2016
5	ESCS30 EMI test receiver	R&S	100029	20 th Aug. 2016
6	HL562 Ultra log test antenna	R&S	100016	20 th Aug. 2016
7	ESH3-Z2 Pulse limiter	R&S	10002	20 th Aug. 2016
8	LS16C AMN	AFJ	16011306281	20 th Aug. 2016
9	ESH2Z11 LISN	R&S	50FH-020-10	20 th Aug. 2016
10	HF 906 Double-Ridged Waveguide Horn Antenna	R&S	100030	20 th Aug. 2016
11	HF 906 Double-Ridged Waveguide Horn Antenna	R&S	100029	20 th Aug. 2016
12	PS2000 Turn Table	FRANKONIA	-----	20 th Aug. 2016
13	MA260 Antenna Master	FRANKONIA	-----	20 th Aug. 2016
14	ES-K1EMI test software	R&S	-----	20 th Aug. 2016
15	HL562 Receive antenna	R&S	100167	20 th Aug. 2016

Appendix

Appendix1 Test Setup