



---

# TEST REPORT

---

Report No.: SRTC2015-9003(F)-0007  
Product Name: GSM/GPRS/EDGE/UMTS/LTE Digital Mobile  
Phone with Bluetooth and WiFi  
Model Name: Philips Xenium V526  
Applicant: Shenzhen Sang Fei Consumer Communications  
Co.,Ltd.  
Manufacturer: Shenzhen Sang Fei Consumer Communications  
Co.,Ltd.  
Specification: FCC Part15B (Certification)  
(October 1, 2013 edition)  
FCC ID: VQRCTV526

The State Radio\_monitoring\_center Testing Center (SRTC)

No.80 Beilishi Road Xicheng District Beijing, China

Tel: 86-10-68009202 Fax: 86-10-68009205

## CONTENTS

1. General information .....	3
1.1 Notes of the test report .....	3
1.2 Information about the testing laboratory.....	3
1.3 Applicant's details .....	3
1.4 Manufacturer's details .....	3
1.5 Application details .....	4
1.6 Reference specification.....	4
1.7 Information of EUT.....	4
1.7.1 General information.....	4
1.7.2 EUT details .....	5
1.7.3 Auxiliary equipment details.....	5
2. Test information .....	6
2.1 Summary of the test results.....	6
2.2 Test result.....	7
2.2.1 Conducted Emissions-FCC Part15.107 .....	7
2.2.2 Radiated Emissions-FCC Part15.109 .....	16
2.3. List of test equipments .....	22
Appendix .....	23

## 1. General information

### 1.1 Notes of the test report

The test report may only be reproduced or published in full. Reproduction or publication of extracts from the report requires the prior written permission of The State Radio\_monitoring\_center Testing Center (SRTC).

The test results relate only to individual items of the samples which have been tested.

### 1.2 Information about the testing laboratory

Company: The State Radio\_monitoring\_center Testing Center (SRTC)  
Address: No.80 Beilishi Road, Xicheng District, Beijing China  
City: Beijing  
Country or Region: China  
Contacted person: Wang Junfeng  
Tel: +86 10 68009181 +86 10 68009202  
Fax: +86 10 68009195 +86 10 68009205  
Email: wangjf@srrc.org.cn / wangjunfeng@srtc.org.cn

### 1.3 Applicant's details

Company: Shenzhen Sang Fei Consumer Communications Co.,Ltd.  
Address: 11 Science & Technology Rd., Shenzhen Hi-tech Industrial Park,  
Nanshan District, Shenzhen  
City: Shenzhen  
Country or Region: P.R.China  
Contacted person: linda zhang  
Tel: 010-68300097  
Fax: 010-68300097  
Email: linda.zhang@sangfei.com

### 1.4 Manufacturer's details

Company: Shenzhen Sang Fei Consumer Communications Co.,Ltd.  
Address: 11 Science & Technology Rd., Shenzhen Hi-tech Industrial Park,  
Nanshan District, Shenzhen  
City: Shenzhen  
Country or Region: P.R.China  
Contacted person: linda zhang  
Tel: 010-68300097  
Fax: 010-68300097  
Email: linda.zhang@sangfei.com

## 1.5 Application details

Date of reception of test sample: 16th Oct. 2015

Date of test: 16th Oct. 2015 to 7th Nov. 2015

## 1.6 Reference specification

FCC Part 15B October 1, 2013 (Certification)

## 1.7 Information of EUT

### 1.7.1 General information

Name of EUT	Philips Xenium V526
FCC ID	VQRCTV526
Frequency Range	GSM850/WCDMA Band V: Tx:824~849MHz Rx:869~894MHz PCS1900/WCDMA Band II/ FDD 2: Tx:1850~1910MHz Rx:1930~1990MHz FDD 3: Tx:1710~1785MHz Rx:1805~1880MHz FDD 4: Tx:1710~1755MHz Rx:2110~2155MHz FDD 7: Tx:2500~2570MHz Rx:2620~2690MHz
Rated Output Power	GSM850:33.0dBm PCS1900:30.0dBm WCDMA:22.5dBm FDD: 22.5dBm
Modulation Type	GSM/GPRS:GMSK EDGE: GMSK WCDMA:QPSK FDD:QPSK/16QAM
Emission Designator	GSM/GPRS EDGE WCDMA FDD
Duplex Mode	FDD
Equipment Class	Class B
Duplex Spacing	GSM850/WCDMA Band V:45MHz PCS1900/WCDMA Band II:80MHz
Antenna Type	PIFA Antenna
Power Supply	Battery or Charger
Rated Power Supply Voltage	3.8V

Extreme Temperature	Lowest: -30°C Highest: +50°C
Extreme Voltage	Minimum: 3.5V Maximum: 4.35V
HW Version	WMCTb
SW Version	Philips_V526_1539_V01_AG_FCC

### 1.7.2 EUT details

Product Name	Model Name	IMEI
GSM/GPRS/EDGE/UMTS/LTE Digital Mobile Phone with Bluetooth and WiFi	Philips Xenium V526	867767020192718 867767020193211

### 1.7.3 Auxiliary equipment details

AE (Auxiliary Equipment) 1#: Charger

Equipment	Charger
Manufacturer	SHENZHEN CYCLELONG POWER-TECH CO.,LTD.
Model Number	SKL-05L10

AE (Auxiliary Equipment) 2#: Charger

Equipment	Charger
Manufacturer	SHENZHEN CYCLELONG POWER-TECH CO.,LTD.
Model Number	SKL-O5K20

AE (Auxiliary Equipment) 3#: Battery

Equipment	Battery
Manufacturer	Shenzhen cyclelong power-tech Co., ltd
Model Number	AB5000AWML



AE (Auxiliary Equipment) 4#: Headset

Equipment	Headset
Manufacturer	Dongguan Tian Zhi Industrial Co., Ltd.
Model Number	TJ-101156

## 2. Test information

### 2.1 Summary of the test results

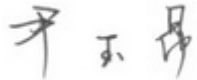
No.	Test case	FCC reference	Verdict
1	Conducted emissions	15.107	Pass
2	Radiated emissions	15.109	Pass

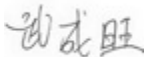
This Test Report Is Issued by: Mr. Yin Yuang Director of the test department  	Checked by: Mr. He Jia Project manager of the test department  
Tested by: Mr. Wu Chengwang Test engineer  	Issued date:  <p style="text-align: center;">2015.11.20</p>

## 2.2 Test result

### 2.2.1 Conducted Emissions-FCC Part15.107

Ambient condition:

Temperature	Relative humidity	Pressure
20.2℃	39.5%	100.8kPa

Test Setup with laptop:

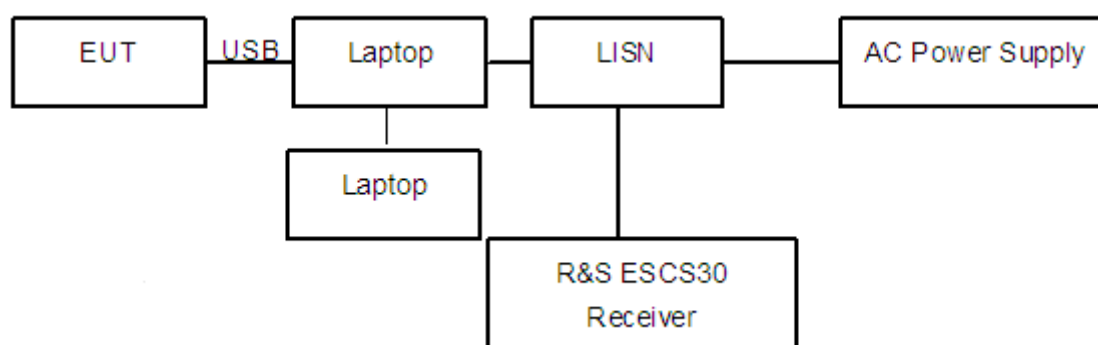

Figure 1

Test Procedure:

The EUT is placed on a non-metallic table 0.8m above the horizontal metal reference ground plane. The accessories of the EUT are connected with the EUT such as headset etc. The EUT was exercised during the testing by data read and write cycles repeated with internal storages connecting with a laptop via the USB cable. The laptop's LAN port is connected with another laptop via cable. And the data transferring between two laptops is maintained.

The AC main power supply of the laptop is connected to LISN and LISN is connected to the reference ground. The test set-up and the test methods are performed according to ANSI C63.4:2014.

Then start the test software ES-K1. Sweep the whole frequency band through the range from 150 KHz to 30 MHz. The measurement should be done for both L line and N line. During pre-test, the receiver uses both peak detector and average detector. And the final test, the receiver uses both average detector and Quasi-peak detector.

The data of cable loss has been calibrated in full testing frequency range before the testing.

Test Setup with charger:

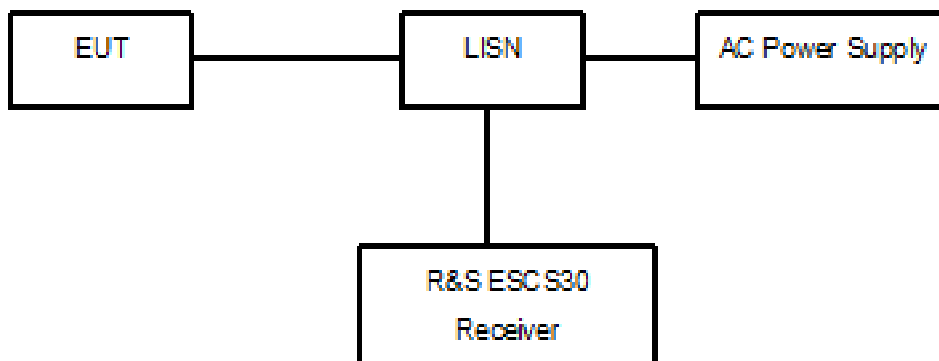

Figure 2

Test Procedure:

The EUT is placed on a non-metallic table 0.8m above the horizontal metal reference ground plane. The EUT is connected with LISN via the charger. The LISN is connected to the reference ground. The accessories of the EUT are connected with the EUT such as headset etc.

The test set-up and the test methods are performed according to ANSI C63.4:2014.

Then start the test software ES-K1. Sweep the whole frequency band through the range from 150 KHz to 30 MHz. The measurement should be done for both L line and N line. During pre-test, the receiver uses both peak detector and average detector. And the final test, the receiver uses both average detector and Quasi-peak detector.

The data of cable loss has been calibrated in full testing frequency range before the testing.



Limit:

Frequency of Emission(MHz)	Limits(dB $\mu$ V)	
	Quasi-peak	Average
0.15~0.5	66 to 56*	56 to 46*
0.5~5	56	46
5~30	60	50

Note: \* Decreases with the logarithm of the frequency

Test result:

Noise Level of the Measuring Instrument

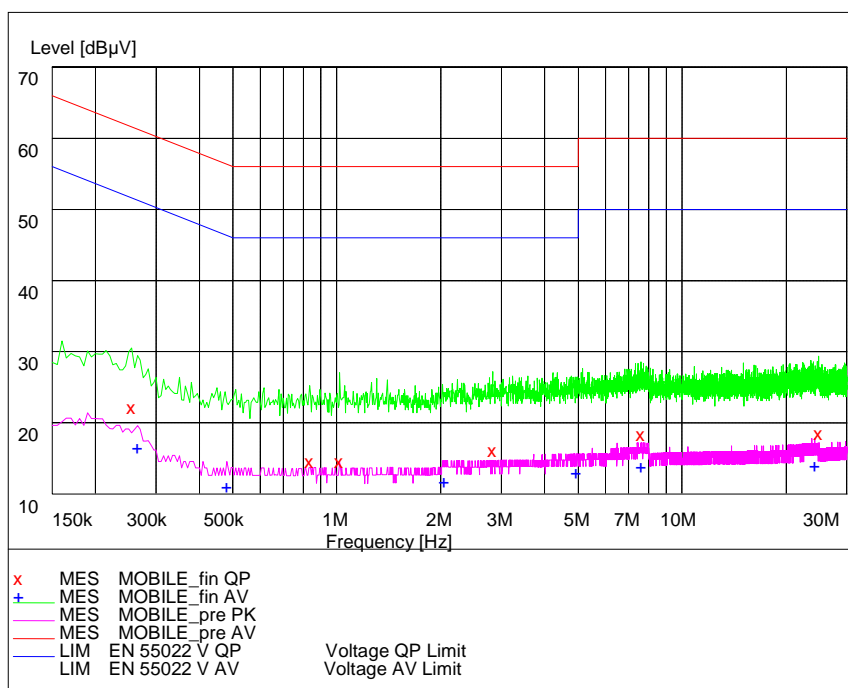

Pic1. Conducted emission L and N Line

EUT+Laptop:

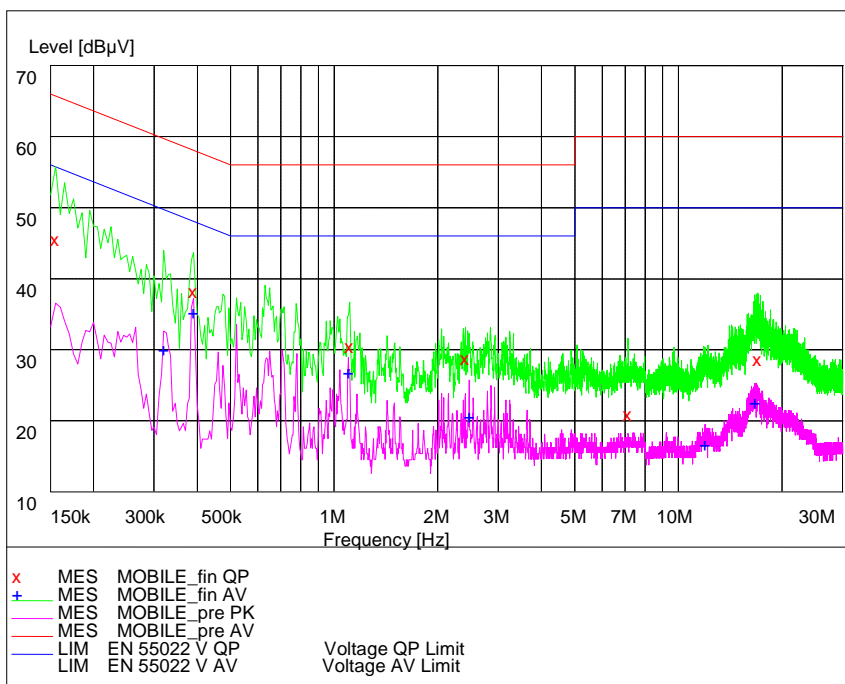

Pic2. Conducted emission L Line

**MEASUREMENT RESULT: "MOBILE\_fin QP"**

Frequency	Level	Transd	Limit	Margin	Line	PE
MHz	dBµV	dB	dBµV	dB		
0.155000	47.20	20.1	66	18.5	---	---
0.390000	39.80	20.1	58	18.2	---	---
1.110000	32.10	20.2	56	23.9	---	---
2.405000	30.50	20.2	56	25.5	---	---
7.150000	22.50	20.5	60	37.5	---	---
17.025000	30.30	20.7	60	29.7	---	---

**MEASUREMENT RESULT: "MOBILE\_fin AV"**

Frequency	Level	Transd	Limit	Margin	Line	PE
MHz	dBµV	dB	dBµV	dB		
0.320000	31.70	20.1	50	18.0	---	---
0.390000	37.00	20.1	48	11.0	---	---
1.100000	28.50	20.2	46	17.5	---	---
2.470000	22.30	20.2	46	23.7	---	---
11.950000	18.40	20.7	50	31.6	---	---
16.735000	24.20	20.7	50	25.8	---	---

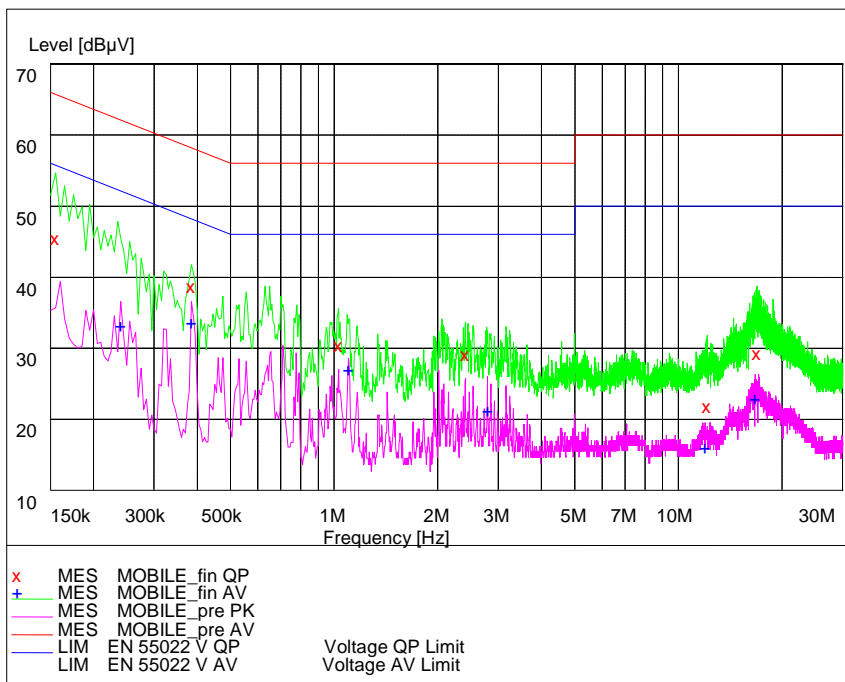

Pic3. Conducted emission N Line

**MEASUREMENT RESULT: "MOBILE\_fin QP"**

Frequency	Level	Transd	Limit	Margin	Line	PE
MHz	dBµV	dB	dBµV	dB		
0.155000	47.00	20.1	66	18.7	---	---
0.385000	40.40	20.1	58	17.8	---	---
1.030000	32.10	20.1	56	23.9	---	---
2.405000	30.80	20.2	56	25.2	---	---
12.125000	23.40	20.7	60	36.6	---	---
16.910000	30.90	20.7	60	29.1	---	---

**MEASUREMENT RESULT: "MOBILE\_fin AV"**

Frequency	Level	Transd	Limit	Margin	Line	PE
MHz	dBµV	dB	dBµV	dB		
0.240000	34.80	20.2	52	17.2	---	---
0.385000	35.30	20.1	48	12.9	---	---
1.100000	28.70	20.2	46	17.3	---	---
2.790000	22.90	20.3	46	23.1	---	---
11.970000	17.70	20.7	50	32.3	---	---
16.725000	24.50	20.7	50	25.5	---	---

EUT+Charger1#:

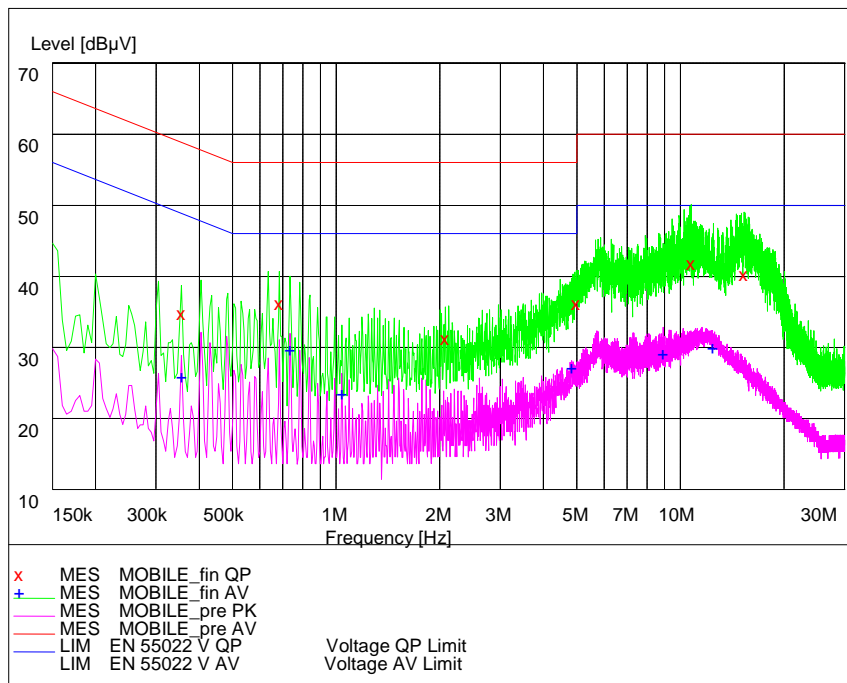

Pic4. Conducted emission L Line

**MEASUREMENT RESULT: "MOBILE\_fin QP"**

Frequency	Level	Transd	Limit	Margin	Line	PE
MHz	dBµV	dB	dBµV	dB		
0.355000	36.40	20.1	59	22.5	---	---
0.685000	37.90	20.1	56	18.1	---	---
2.075000	33.00	20.3	56	23.0	---	---
4.985000	37.90	20.4	56	18.1	---	---
10.770000	43.50	20.6	60	16.5	---	---
15.315000	41.90	20.7	60	18.1	---	---

**MEASUREMENT RESULT: "MOBILE\_fin AV"**

Frequency	Level	Transd	Limit	Margin	Line	PE
MHz	dBµV	dB	dBµV	dB		
0.355000	27.60	20.1	49	21.2	---	---
0.735000	31.30	20.1	46	14.7	---	---
1.040000	25.20	20.1	46	20.8	---	---
4.835000	28.90	20.4	46	17.1	---	---
8.915000	30.90	20.5	50	19.1	---	---
12.420000	31.70	20.7	50	18.3	---	---

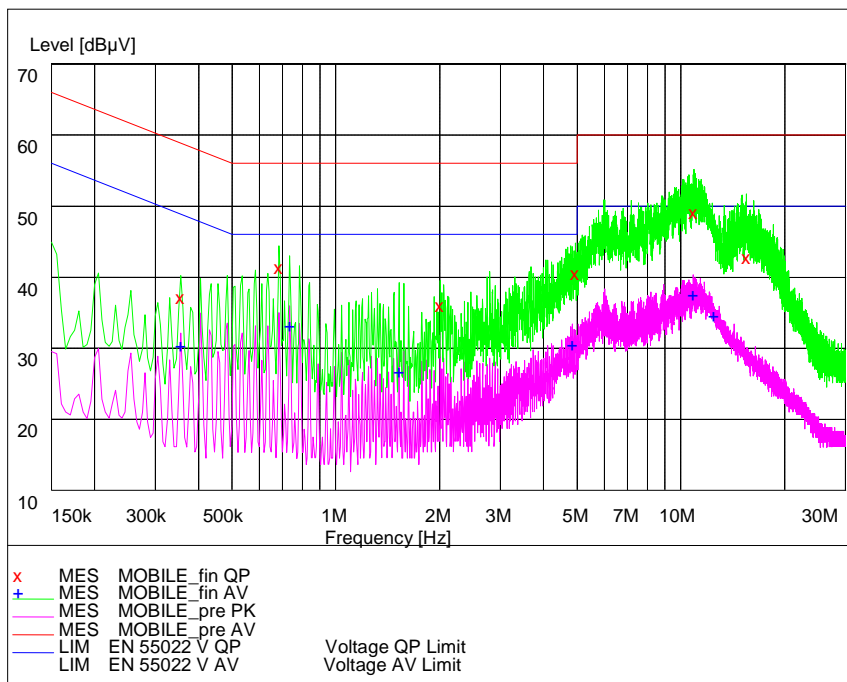

Pic5. Conducted emission N Line

**MEASUREMENT RESULT: "MOBILE\_fin QP"**

Frequency	Level	Transd	Limit	Margin	Line	PE
MHz	dBµV	dB	dBµV	dB		
0.355000	38.80	20.1	59	20.1	---	---
0.685000	43.00	20.1	56	13.0	---	---
2.005000	37.70	20.3	56	18.3	---	---
4.955000	42.20	20.4	56	13.8	---	---
10.920000	50.80	20.6	60	9.2	---	---
15.485000	44.40	20.8	60	15.6	---	---

**MEASUREMENT RESULT: "MOBILE\_fin AV"**

Frequency	Level	Transd	Limit	Margin	Line	PE
MHz	dBµV	dB	dBµV	dB		
0.355000	32.00	20.1	49	16.9	---	---
0.735000	34.80	20.1	46	11.2	---	---
1.525000	28.40	20.2	46	17.6	---	---
4.850000	32.30	20.4	46	13.7	---	---
10.870000	39.20	20.6	50	10.8	---	---
12.445000	36.20	20.7	50	13.8	---	---

EUT+Charger2#:

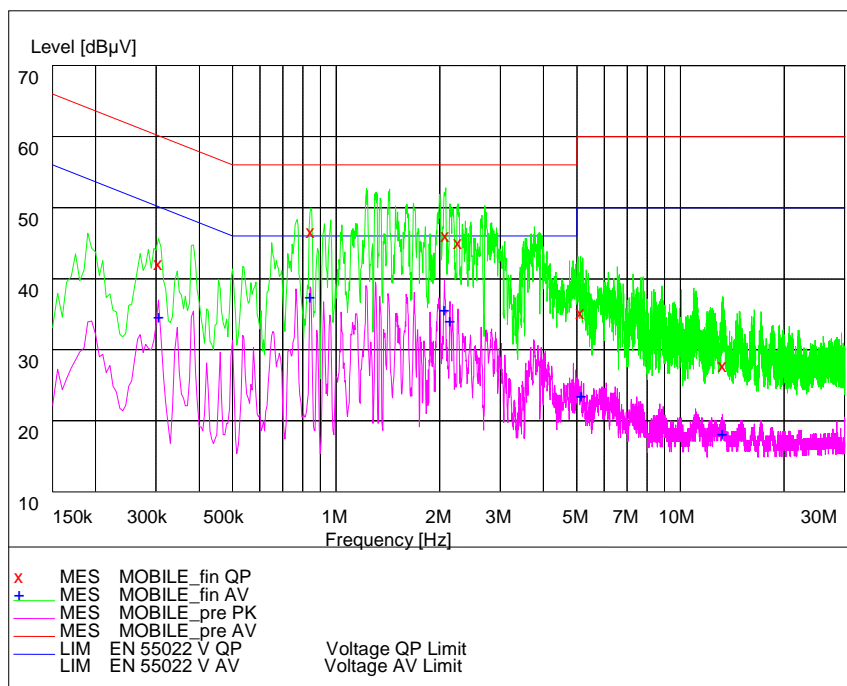

Pic6. Conducted emission L Line

**MEASUREMENT RESULT: "MOBILE\_fin QP"**

Frequency	Level	Transd	Limit	Margin	Line	PE
MHz	dBµV	dB	dBµV	dB		
0.305000	43.80	20.2	60	16.3	---	---
0.845000	48.30	20.2	56	7.7	---	---
2.085000	47.70	20.3	56	8.3	---	---
2.260000	46.80	20.3	56	9.2	---	---
5.140000	36.90	20.4	60	23.1	---	---
13.300000	29.50	20.7	60	30.5	---	---

**MEASUREMENT RESULT: "MOBILE\_fin AV"**

Frequency	Level	Transd	Limit	Margin	Line	PE
MHz	dBµV	dB	dBµV	dB		
0.305000	36.30	20.2	50	13.8	---	---
0.840000	39.10	20.2	46	6.9	---	---
2.065000	37.40	20.3	46	8.6	---	---
2.140000	35.80	20.3	46	10.2	---	---
5.160000	25.20	20.3	50	24.8	---	---
13.270000	19.90	20.7	50	30.1	---	---

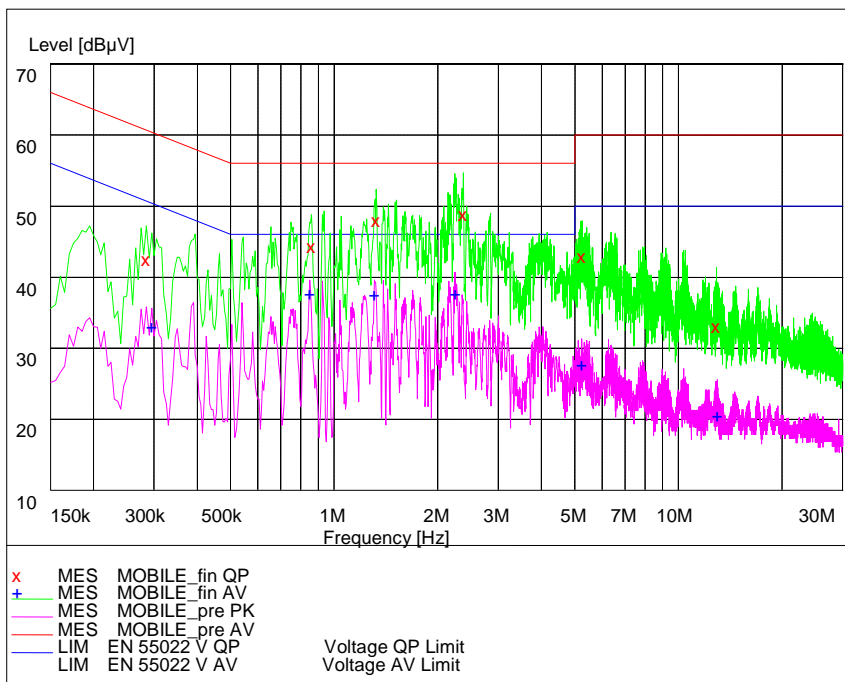

Pic7. Conducted emission N Line

**MEASUREMENT RESULT: "MOBILE\_fin QP"**

Frequency	Level	Transd	Limit	Margin	Line	PE
MHz	dBµV	dB	dBµV	dB		
0.285000	44.20	20.1	61	16.5	---	---
0.860000	45.90	20.2	56	10.1	---	---
1.325000	49.60	20.2	56	6.4	---	---
2.375000	50.40	20.2	56	5.6	---	---
5.255000	44.50	20.4	60	15.5	---	---
12.920000	34.70	20.7	60	25.3	---	---

**MEASUREMENT RESULT: "MOBILE\_fin AV"**

Frequency	Level	Transd	Limit	Margin	Line	PE
MHz	dBµV	dB	dBµV	dB		
0.295000	34.70	20.2	50	15.7	---	---
0.850000	39.30	20.2	46	6.7	---	---
1.310000	39.20	20.2	46	6.8	---	---
2.250000	39.40	20.3	46	6.6	---	---
5.245000	29.40	20.4	50	20.6	---	---
12.990000	22.10	20.7	50	27.9	---	---

## 2.2.2 Radiated Emissions-FCC Part15.109

Ambient condition:

Temperature	Relative humidity	Pressure
20.6°C	39.2%	100.8kPa

Test Setup:

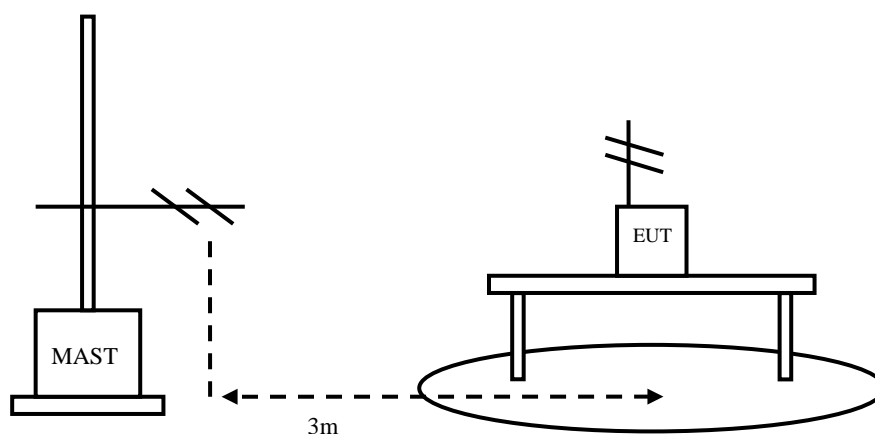

Figure 3

Test Procedure:

EUT+Laptop:

The EUT should be placed on a non-metallic table 80cm above the ground plane. The receive antennas shall be moved from 1 to 4 meters. The distance between EUT and receive antenna should be 3 meters.

The accessories of the EUT are connected with the EUT such as headset etc. The EUT was exercised during the testing by data read and write cycles repeated with internal storages connecting with a laptop via the USB cable. The laptop's LAN port is connected with another laptop via cable. And the data transferring between two laptops is maintained. The test set-up and the test methods are performed according to ANSI C63.4:2014

Then start the test software ES-K1. Sweep the whole frequency band through the range from 30MHz to 1GHz, using receive log period antenna HL562.

During the test, the height of receive antenna shall be moved from 1 to 4 meters, and the antenna shall be performed under horizontal and vertical polarization. The turn table shall be rotated from 0 to 360 degrees for detecting the maximum of radiated spurious signal level. The measurements shall be repeated with



orthogonal polarization of the test antenna. The EUT is laid in two modes as follow:  
1. put the EUT in horizontal direction; 2. put the EUT in vertical direction.  
The data of cable loss and antenna factor have been calibrated in full testing frequency range before the testing.

**EUT+Charger:**

The EUT should be placed on a non-metallic table 80cm above the ground plane. The receive antennas shall be moved from 1 to 4 meters. The distance between EUT and receive antenna should be 3 meters.

The EUT should work in idle mode. The accessories of the EUT are connected with the EUT such as headset etc. The test set-up and the test methods are performed according to ANSI C63.4:2014.

Then start the test software ES-K1. Sweep the whole frequency band through the range from 30MHz to 1GHz, using receive log period antenna HL562.

During the test, the height of receive antenna shall be moved from 1 to 4 meters, and the antenna shall be performed under horizontal and vertical polarization. The turn table shall be rotated from 0 to 360 degrees for detecting the maximum of radiated spurious signal level. The measurements shall be repeated with orthogonal polarization of the test antenna. The EUT is laid in two modes as follow:  
1. put the EUT in horizontal direction; 2. put the EUT in vertical direction.

The data of cable loss and antenna factor have been calibrated in full testing frequency range before the testing.

A “reference path loss” is established and the  $A_{Rpl}$  is the attenuation of “reference path loss”, and including the gain of receive antenna, the gain of the preamplifier, the cable loss.

The measurement results are obtained as described below:

$$\text{Result} = P_{\text{mea}} + A_{Rpl}$$

Limit:

Frequency of Emission(MHz)	Limits	
	Detector	Unit (dB $\mu$ V/m)
30~88	Quasi-peak	40
88~216	Quasi-peak	43.5
216~960	Quasi-peak	46
960~1000	Quasi-peak	54
1000~5th harmonic of the highest frequency or 40GHz, whichever is lower	Average	54
	Peak	74

Test result:  
EUT+Laptop

Frequency(MHz)	Result(dBuV/m)	ARpl (dB)	Pmea (dBuV/m)	Polarity
172.945892	14.80	10.6	4.20	Horizontal
177.755511	20.10	10.8	9.3	Horizontal
179.358717	26.90	10.9	16.0	Horizontal
180.961924	33.70	10.9	22.8	Horizontal
206.613226	22.50	11.6	10.9	Horizontal
209.018036	24.10	11.8	12.3	Horizontal

EUT+Charger1#

Frequency(MHz)	Result(dBuV/m)	ARpl (dB)	Pmea (dBuV/m)	Polarity
39.819639	27.40	15.6	11.8	Vertical
63.527054	20.10	7.2	12.9	Vertical
67.875752	28.30	7.9	20.4	Vertical
69.418838	21.40	8.0	13.4	Vertical
70.821643	26.20	8.3	17.9	Vertical
213.827655	30.20	11.9	18.3	Horizontal

EUT+Charger2#

Frequency(MHz)	Result(dBuV/m)	ARpl (dB)	Pmea (dBuV/m)	Polarity
30.701403	25.90	20.6	5.3	Vertical
40.240481	24.00	15.4	8.6	Vertical
60.721443	26.40	7.1	19.3	Vertical
67.595190	28.10	7.9	20.2	Vertical
84.148297	24.70	10.3	14.4	Vertical
211.422846	31.60	11.9	19.7	Horizontal

EUT+Laptop:

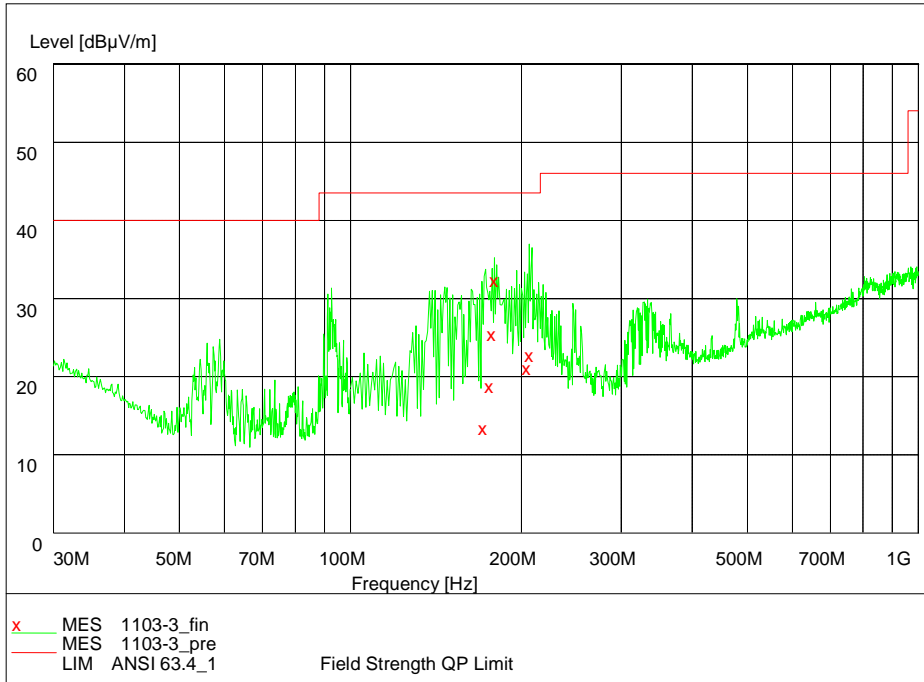

Pic8. Radiated emission (30MHz – 1GHz)

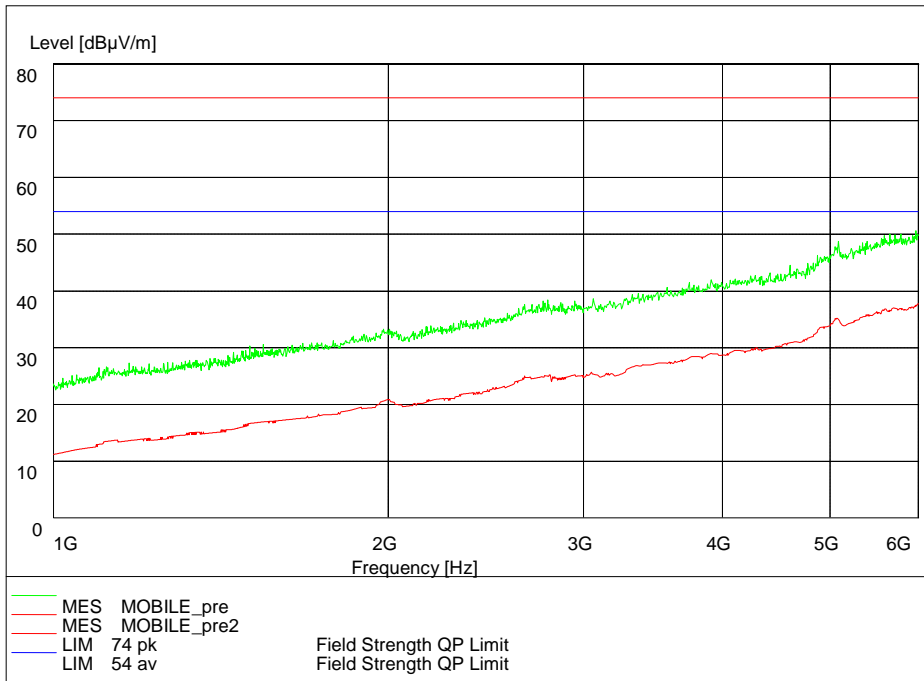

Pic9. Radiated emission (1GHz – 6GHz)

EUT+Charger1#:

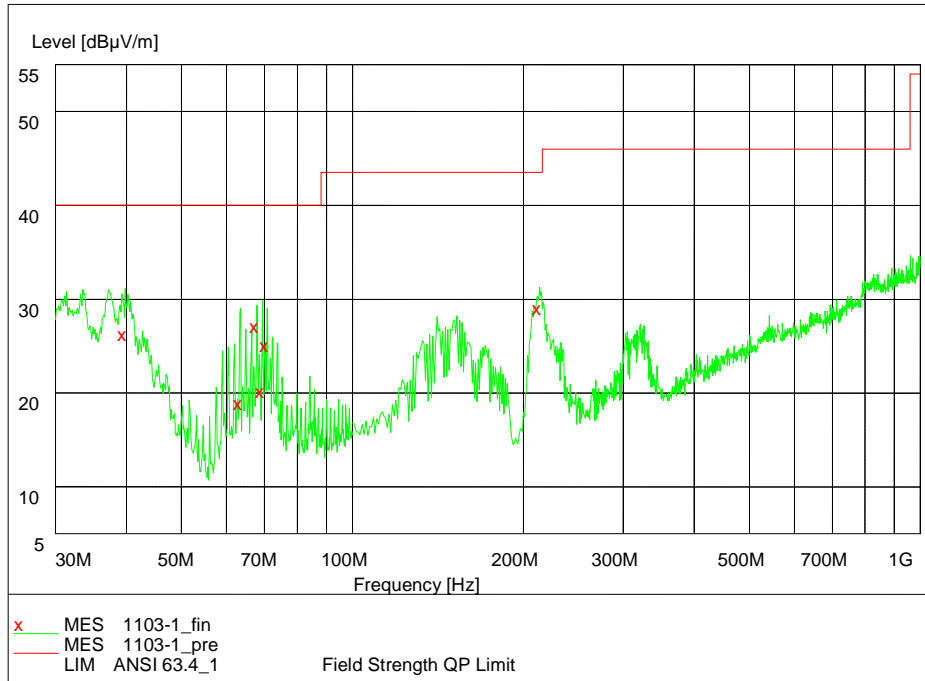

Pic10. Radiated emission (30MHz – 1GHz)

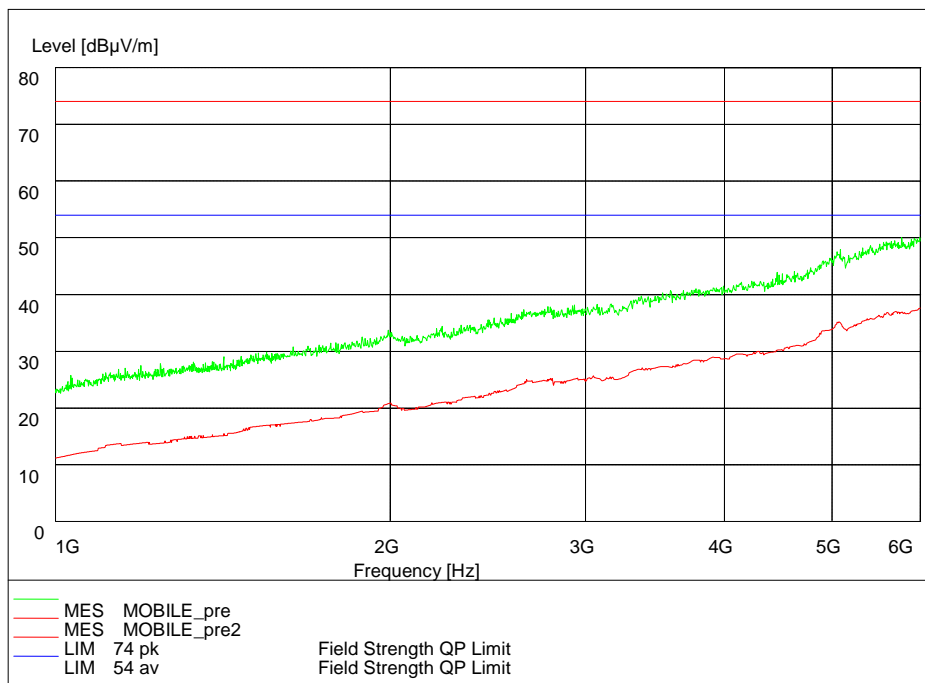

Pic11. Radiated emission (1GHz – 6GHz)

EUT+Charger2#:

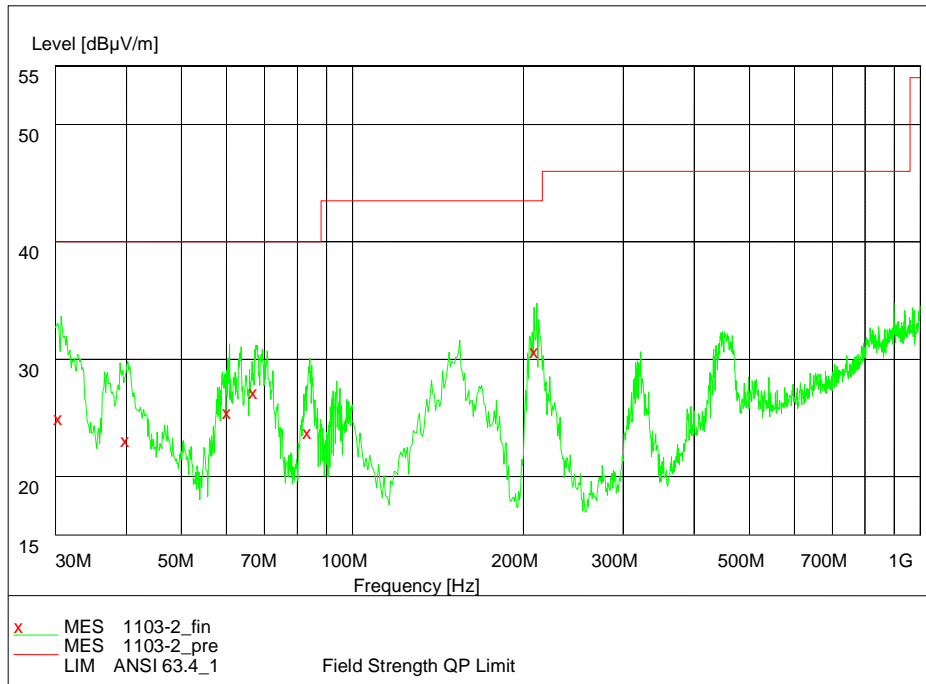

Pic12. Radiated emission (30MHz – 1GHz)

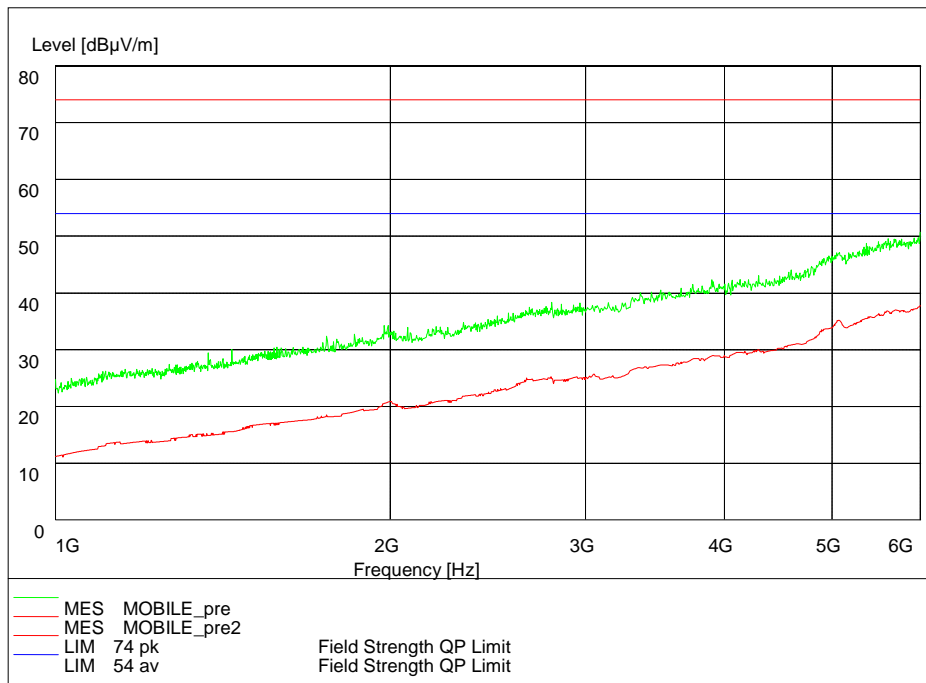

Pic13. Radiated emission (1GHz – 6GHz)

## 2.3. List of test equipments

No.	Name/Model	Manufacturer	S/N	Calibration Due Date
1	23.18m×16.88m×9.60m Semi-Anechoic Chamber	FRANKONIA	-----	20th Aug. 2016
2	ESI 40 EMI test receiver	R&S	100015	20th Aug. 2016
3	E5515C(8960) Mobile Station Tester	Agilent	GB44050904	20th Aug. 2016
4	9.080m×5.255m×3.525m Shielding room	FRANKONIA	-----	20th Aug. 2016
5	ESCS30 EMI test receiver	R&S	100029	20th Aug. 2016
6	HL562 Ultra log test antenna	R&S	100016	20th Aug. 2016
7	ESH3-Z2 Pulse limiter	R&S	10002	20th Aug. 2016
8	LS16C AMN	AFJ	16011306281	20th Aug. 2016
9	ESH2Z11 LISN	R&S	50FH-020-10	20th Aug. 2016
10	HF 906 Double-Ridged Waveguide Horn Antenna	R&S	100030	20th Aug. 2016
11	HF 906 Double-Ridged Waveguide Horn Antenna	R&S	100029	20th Aug. 2016
12	PS2000 Turn Table	FRANKONIA	-----	20th Aug. 2016
13	MA260 Antenna Master	FRANKONIA	-----	20th Aug. 2016
14	ES-K1EMI test software	R&S	-----	20th Aug. 2016
15	HL562 Receive antenna	R&S	100167	20th Aug. 2016

## Appendix

### Appendix1 Test Setup