



TEST REPORT

Report No.: SRTC2015-9003(F)-0006
Product Name: GSM/GPRS/EDGE/UMTS Digital Mobile Phone
with Bluetooth and WiFi
Model Name: Philips S358
Applicant: Shenzhen Sang Fei Consumer Communications
Co.,Ltd.
Manufacturer: Shenzhen Sang Fei Consumer Communications
Co.,Ltd.
Specification: FCC Part15B (Certification)
(October 1, 2013 edition)
FCC ID: VQRCTS358

The State Radio_monitoring_center Testing Center (SRTC)

No.80 Beilishi Road Xicheng District Beijing, China

Tel: 86-10-68009202 Fax: 86-10-68009205

CONTENTS

1. General information	3
1.1 Notes of the test report	3
1.2 Information about the testing laboratory.....	3
1.3 Applicant's details	3
1.4 Manufacturer's details.....	3
1.5 Application details	4
1.6 Reference specification.....	4
1.7 Information of EUT.....	4
1.7.1 General information.....	4
1.7.2 EUT details	5
1.7.3 Auxiliary equipment details.....	5
2. Test information	6
2.1 Summary of the test results.....	6
2.2 Test result.....	7
2.2.1 Conducted Emissions-FCC Part15.107	7
2.2.2 Radiated Emissions-FCC Part15.109	14
2.3. List of test equipments	19
Appendix	20

1. General information

1.1 Notes of the test report

The test report may only be reproduced or published in full. Reproduction or publication of extracts from the report requires the prior written permission of The State Radio_monitoring_center Testing Center (SRTC).

The test results relate only to individual items of the samples which have been tested.

1.2 Information about the testing laboratory

Company: The State Radio_monitoring_center Testing Center (SRTC)
Address: No.80 Beilishi Road, Xicheng District, Beijing China
City: Beijing
Country or Region: China
Contacted person: Wang Junfeng
Tel: +86 10 68009181 +86 10 68009202
Fax: +86 10 68009195 +86 10 68009205
Email: wangjf@srrc.org.cn / wangjunfeng@srctc.org.cn

1.3 Applicant's details

Company: Shenzhen Sang Fei Consumer Communications Co.,Ltd.
Address: 11 Science & Technology Rd., Shenzhen Hi-tech Industrial Park,
Nanshan District, Shenzhen
City: Shenzhen
Country or Region: P.R.China
Contacted person: Helen.Lin
Tel: 0755-33308888
Fax: 0755-26614979
Email: Helen.Lin@sangfei.com

1.4 Manufacturer's details

Company: Shenzhen Sang Fei Consumer Communications Co.,Ltd.
Address: 11 Science & Technology Rd., Shenzhen Hi-tech Industrial Park,
Nanshan District, Shenzhen
City: Shenzhen
Country or Region: P.R.China
Contacted person: Helen.Lin
Tel: 0755-33308888
Fax: 0755-26614979
Email: Helen.Lin@sangfei.com

1.5 Application details

Date of reception of test sample: 7th Aug. 2015

Date of test: 7th Aug. 2015 to 27th Aug. 2015

1.6 Reference specification

FCC Part 15B October 1, 2013 (Certification)

1.7 Information of EUT

1.7.1 General information

Name of EUT	GSM/GPRS/EDGE/UMTS Digital Mobile Phone with Bluetooth and WiFi
FCC ID	VQRCTS358
Frequency Range	GSM850/WCDMA Band V: Tx:824~849MHz Rx:869~894MHz PCS1900/WCDMA Band II: Tx:1850~1910MHz Rx:1930~1990MHz
Rated Output Power	GSM850:33.0dBm PCS1900:30.0dBm WCDMA:24.0dBm
Modulation Type	GSM/GPRS:GMSK EDGE: GMSK WCDMA:QPSK
Emission Designator	GSM/GPRS EDGE WCDMA
Duplex Mode	FDD
Equipment Class	Class B
Duplex Spacing	GSM850/WCDMA Band V:45MHz PCS1900/WCDMA Band II:80MHz
Antenna Type	PIFA Antenna
Power Supply	Battery or Charger
Rated Power Supply Voltage	3.8V
Extreme Temperature	Lowest: -30°C Highest: +50°C
Extreme Voltage	Minimum: 3.5V Maximum: 4.35V
HW Version	WMCVc
SW Version	Philips_S358_1530_V06_VN

1.7.2 EUT details

Product Name	Model Name	IMEI
GSM/GPRS/EDGE/UMTS Digital Mobile Phone with Bluetooth and WiFi	Philips S358	866636024004834 866636024004842

1.7.3 Auxiliary equipment details

AE (Auxiliary Equipment) 1#: Charger

Equipment	Charger
Manufacturer	SHENZHEN CYCLELONG POWER-TECH CO.,LTD.
Model Number	SKL-05L10
S/N	---
Input Voltage	100-240V a.c.
Output Voltage	5.0V d.c.
Frequency	50/60Hz

AE (Auxiliary Equipment) 2#: Battery

Equipment	Battery
Manufacturer	Shenzhen tour Kelon Power Technology Co.,Ltd.
Model Number	AB2300AWML
Capacity	2300mAh
Rated Voltage	4.35V d.c.

AE (Auxiliary Equipment) 3#: Headset

Equipment	Headset
Manufacturer	Dong Guan Tenji Technology Industrial Co.,Ltd
Model Number	TJ-101179

2. Test information

2.1 Summary of the test results

No.	Test case	FCC reference	Verdict
1	Conducted emissions	15.107	Pass
2	Radiated emissions	15.109	Pass

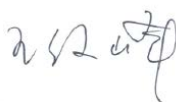
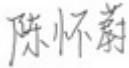
This Test Report Is Issued by: Mr. Song Qizhu Director of the test lab 	Checked by: Mr. Wang Junfeng Deputy director of the test lab 
Tested by: Mr. Chen Huaiwei Test engineer 	Issued date: 2015.8.28

2.2 Test result

2.2.1 Conducted Emissions-FCC Part15.107

Ambient condition:

Temperature	Relative humidity	Pressure
21.4	37.3%	101.1kPa

Test Setup with laptop:

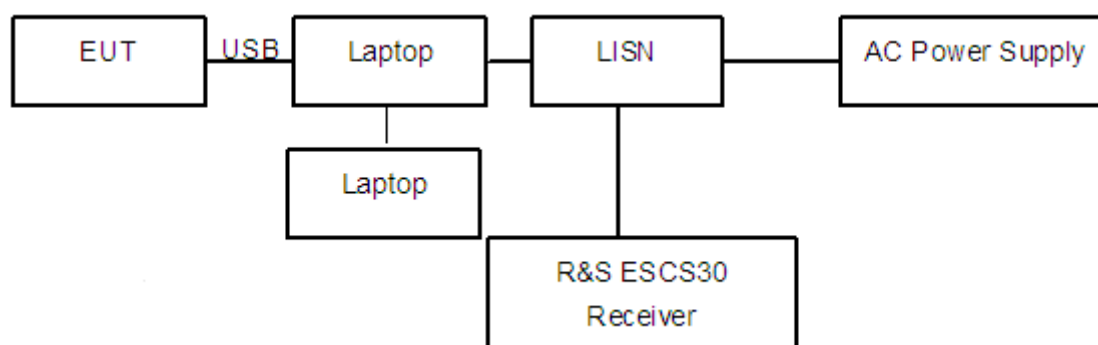

Figure 1

Test Procedure:

The EUT is placed on a non-metallic table 0.8m above the horizontal metal reference ground plane. The accessories of the EUT are connected with the EUT such as headset etc. The EUT was exercised during the testing by data read and write cycles repeated with internal storages connecting with a laptop via the USB cable. The laptop's LAN port is connected with another laptop via cable. And the data transferring between two laptops is maintained.

The AC main power supply of the laptop is connected to LISN and LISN is connected to the reference ground. The test set-up and the test methods are performed according to ANSI C63.4:2014.

Then start the test software ES-K1. Sweep the whole frequency band through the range from 150 KHz to 30 MHz. The measurement should be done for both L line and N line. During pre-test, the receiver uses both peak detector and average detector. And the final test, the receiver uses both average detector and Quasi-peak detector.

The data of cable loss has been calibrated in full testing frequency range before the testing.

Test Setup with charger:

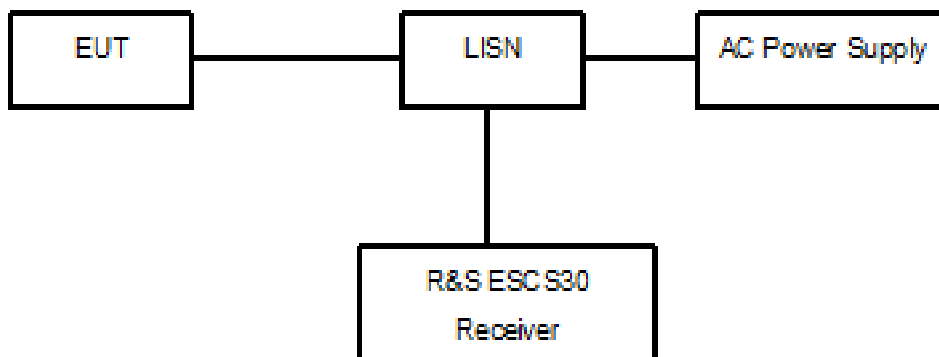

Figure 2

Test Procedure:

The EUT is placed on a non-metallic table 0.8m above the horizontal metal reference ground plane. The EUT is connected with LISN via the charger. The LISN is connected to the reference ground. The accessories of the EUT are connected with the EUT such as headset etc.

The test set-up and the test methods are performed according to ANSI C63.4:2014.

Then start the test software ES-K1. Sweep the whole frequency band through the range from 150 KHz to 30 MHz. The measurement should be done for both L line and N line. During pre-test, the receiver uses both peak detector and average detector. And the final test, the receiver uses both average detector and Quasi-peak detector.

The data of cable loss has been calibrated in full testing frequency range before the testing.

Limit:

Frequency of Emission(MHz)	Limits(dB μ V)	
	Quasi-peak	Average
0.15~0.5	66 to 56*	56 to 46*
0.5~5	56	46
5~30	60	50

Note: * Decreases with the logarithm of the frequency

Test result:

Noise Level of the Measuring Instrument

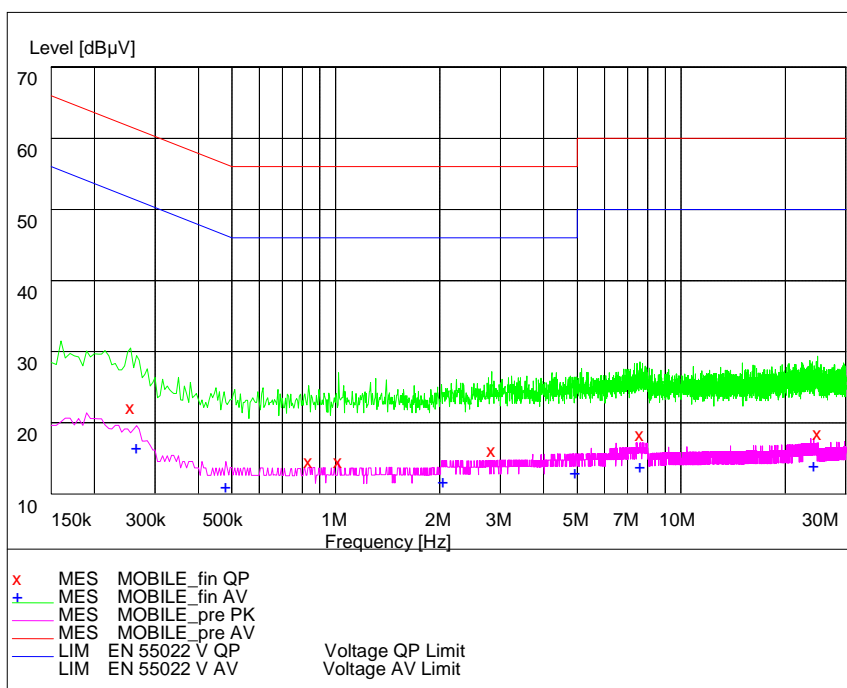

Pic1. Conducted emission L and N Line

EUT+Laptop:

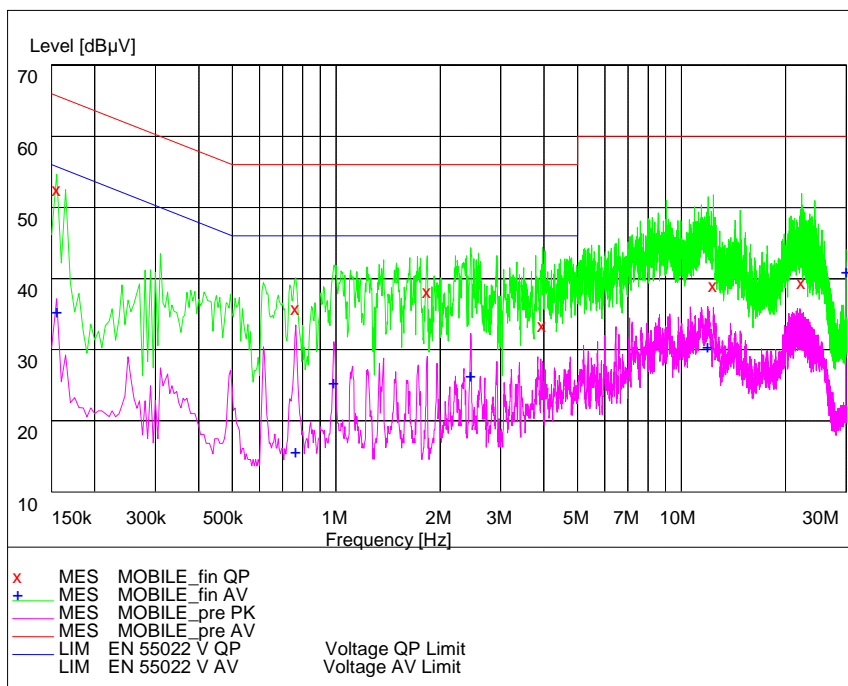

Pic2. Conducted emission L Line

MEASUREMENT RESULT: "MOBILE_fin QP"

Frequency	Level	Transd	Limit	Margin	Line	PE
MHz	dBµV	dB	dBµV	dB		
0.155000	54.10	20.1	66	11.6	---	---
0.765000	37.50	20.0	56	18.5	---	---
1.835000	39.90	20.1	56	16.1	---	---
3.965000	35.20	20.3	56	20.8	---	---
12.370000	40.70	20.7	60	19.3	---	---
22.290000	41.10	21.0	60	18.9	---	---

MEASUREMENT RESULT: "MOBILE_fin AV"

Frequency	Level	Transd	Limit	Margin	Line	PE
MHz	dBµV	dB	dBµV	dB		
0.155000	37.00	20.1	56	18.7	---	---
0.765000	17.30	20.0	46	28.7	---	---
0.985000	27.10	20.1	46	18.9	---	---
2.455000	28.00	20.2	46	18.0	---	---
11.935000	32.10	20.7	50	17.9	---	---
30.000000	42.60	21.3	50	7.4	---	---

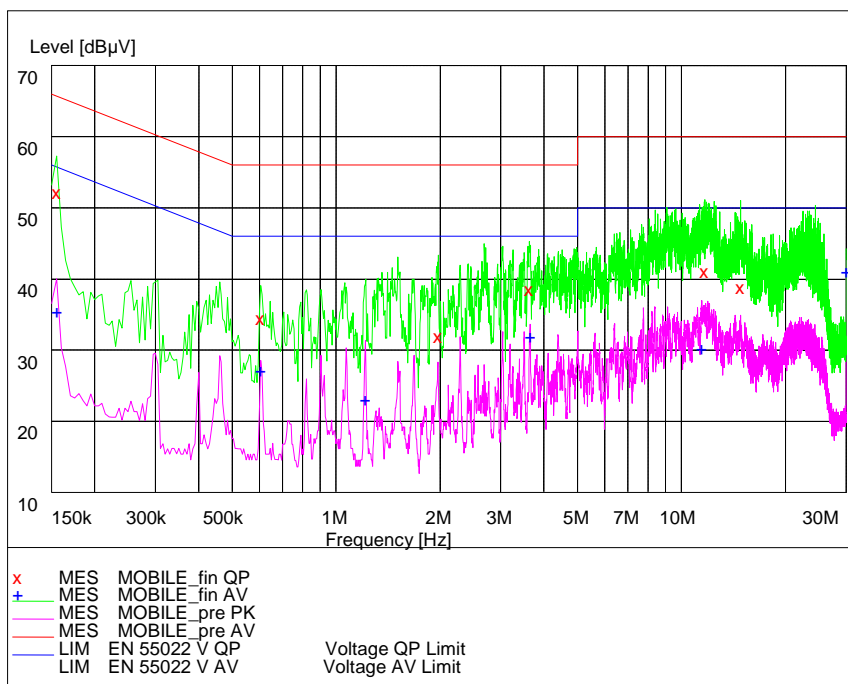

Pic3. Conducted emission N Line

MEASUREMENT RESULT: "MOBILE_fin QP"

Frequency	Level	Transd	Limit	Margin	Line	PE
MHz	dBµV	dB	dBµV	dB		
0.155000	53.80	20.1	66	11.9	---	---
0.605000	36.10	20.1	56	19.9	---	---
1.980000	33.60	20.3	56	22.4	---	---
3.630000	40.20	20.3	56	15.8	---	---
11.705000	42.70	20.7	60	17.3	---	---
14.865000	40.40	20.7	60	19.6	---	---

MEASUREMENT RESULT: "MOBILE_fin AV"

Frequency	Level	Transd	Limit	Margin	Line	PE
MHz	dBµV	dB	dBµV	dB		
0.155000	37.20	20.1	56	18.5	---	---
0.605000	28.80	20.1	46	17.2	---	---
1.215000	24.80	20.1	46	21.2	---	---
3.650000	33.60	20.3	46	12.4	---	---
11.455000	31.90	20.6	50	18.1	---	---
30.000000	42.70	21.3	50	7.3	---	---

EUT+Charger:

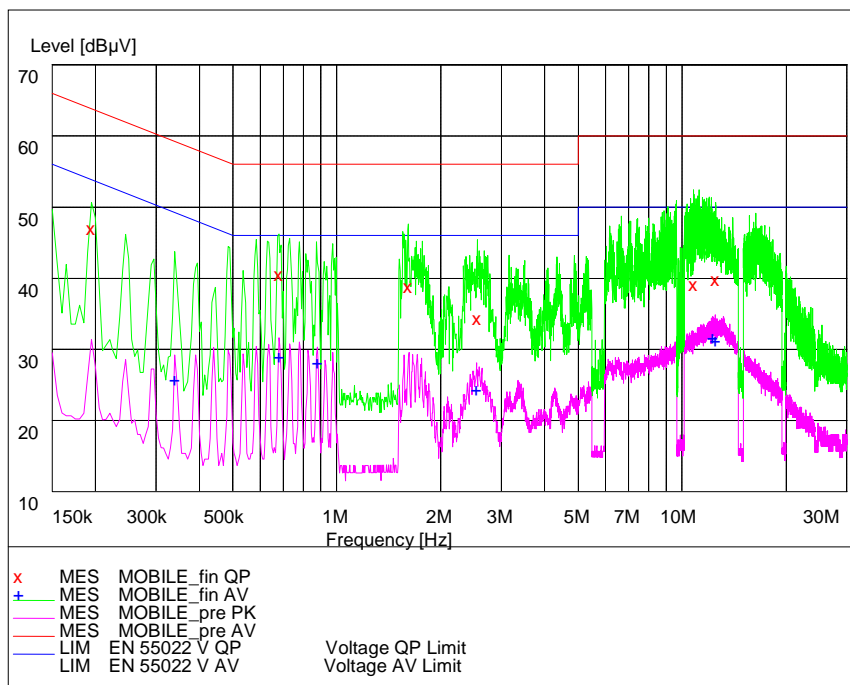

Pic4. Conducted emission L Line

MEASUREMENT RESULT: "MOBILE_fin QP"

Frequency MHz	Level dBµV	Transd dB	Limit dBµV	Margin dB	Line	PE
0.195000	48.60	20.2	64	15.3	---	---
0.680000	42.20	20.2	56	13.8	---	---
1.610000	40.50	20.2	56	15.5	---	---
2.555000	36.00	20.2	56	20.0	---	---
10.805000	40.70	20.6	60	19.3	---	---
12.505000	41.50	20.7	60	18.5	---	---

MEASUREMENT RESULT: "MOBILE_fin AV"

Frequency MHz	Level dBµV	Transd dB	Limit dBµV	Margin dB	Line	PE
0.340000	27.40	20.1	49	21.8	---	---
0.680000	30.60	20.2	46	15.4	---	---
0.880000	29.80	20.2	46	16.2	---	---
2.540000	26.00	20.2	46	20.0	---	---
12.280000	33.30	20.7	50	16.7	---	---
12.475000	33.00	20.7	50	17.0	---	---

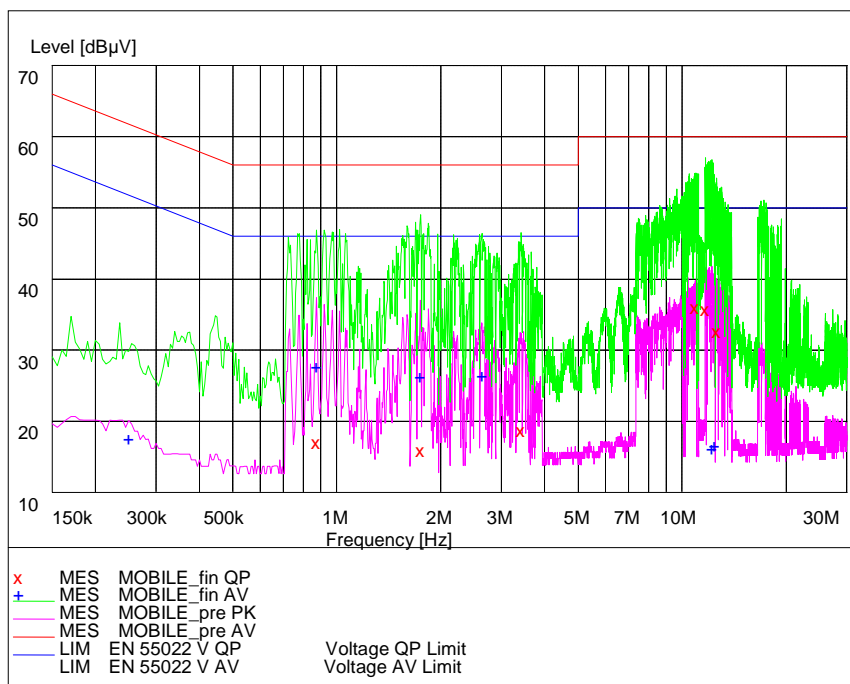

Pic5. Conducted emission N Line

MEASUREMENT RESULT: "MOBILE_fin QP"

Frequency	Level	Transd	Limit	Margin	Line	PE
MHz	dBµV	dB	dBµV	dB		
0.875000	18.70	20.2	56	37.3	---	---
1.750000	17.50	20.2	56	38.5	---	---
3.420000	20.30	20.3	56	35.7	---	---
10.925000	37.70	20.6	60	22.3	---	---
11.700000	37.30	20.7	60	22.7	---	---
12.595000	34.30	20.7	60	25.7	---	---

MEASUREMENT RESULT: "MOBILE_fin AV"

Frequency	Level	Transd	Limit	Margin	Line	PE
MHz	dBµV	dB	dBµV	dB		
0.250000	19.20	20.1	52	32.6	---	---
0.875000	29.30	20.2	46	16.7	---	---
1.745000	27.90	20.2	46	18.1	---	---
2.630000	28.10	20.2	46	17.9	---	---
12.185000	17.90	20.7	50	32.1	---	---
12.410000	18.30	20.7	50	31.7	---	---

2.2.2 Radiated Emissions-FCC Part15.109

Ambient condition:

Temperature	Relative humidity	Pressure
20.8°C	35.1%	100.9kPa

Test Setup:

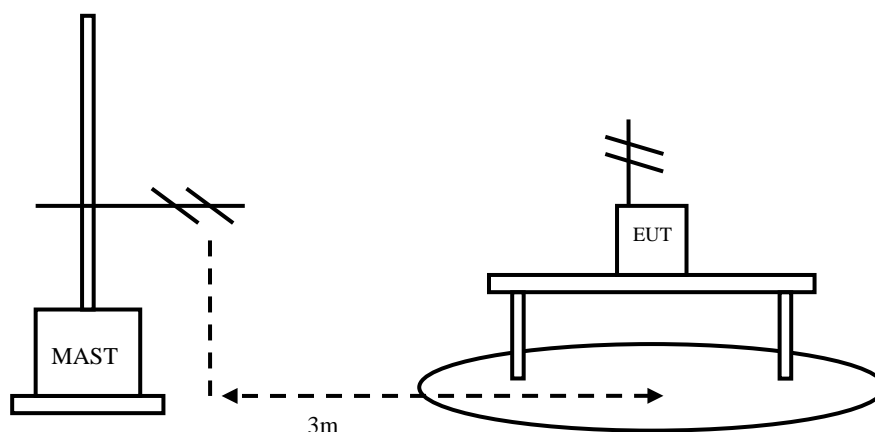

Figure 3

Test Procedure:

EUT+Laptop:

The EUT should be placed on a non-metallic table 80cm above the ground plane. The receive antennas shall be moved from 1 to 4 meters. The distance between EUT and receive antenna should be 3 meters.

The accessories of the EUT are connected with the EUT such as headset etc. The EUT was exercised during the testing by data read and write cycles repeated with internal storages connecting with a laptop via the USB cable. The laptop's LAN port is connected with another laptop via cable. And the data transferring between two laptops is maintained. The test set-up and the test methods are performed according to ANSI C63.4:2014

Then start the test software ES-K1. Sweep the whole frequency band through the range from 30MHz to 1GHz, using receive log period antenna HL562.

During the test, the height of receive antenna shall be moved from 1 to 4 meters, and the antenna shall be performed under horizontal and vertical polarization. The turn table shall be rotated from 0 to 360 degrees for detecting the maximum of radiated spurious signal level. The measurements shall be repeated with

orthogonal polarization of the test antenna. The EUT is laid in two modes as follow:
1. put the EUT in horizontal direction; 2. put the EUT in vertical direction.
The data of cable loss and antenna factor have been calibrated in full testing frequency range before the testing.

EUT+Charger:

The EUT should be placed on a non-metallic table 80cm above the ground plane. The receive antennas shall be moved from 1 to 4 meters. The distance between EUT and receive antenna should be 3 meters.

The EUT should work in idle mode. The accessories of the EUT are connected with the EUT such as headset etc. The test set-up and the test methods are performed according to ANSI C63.4:2014.

Then start the test software ES-K1. Sweep the whole frequency band through the range from 30MHz to 1GHz, using receive log period antenna HL562.

During the test, the height of receive antenna shall be moved from 1 to 4 meters, and the antenna shall be performed under horizontal and vertical polarization. The turn table shall be rotated from 0 to 360 degrees for detecting the maximum of radiated spurious signal level. The measurements shall be repeated with orthogonal polarization of the test antenna. The EUT is laid in two modes as follow:
1. put the EUT in horizontal direction; 2. put the EUT in vertical direction.

The data of cable loss and antenna factor have been calibrated in full testing frequency range before the testing.

A “reference path loss” is established and the A_{Rpl} is the attenuation of “reference path loss”, and including the gain of receive antenna, the gain of the preamplifier, the cable loss.

The measurement results are obtained as described below:

$$\text{Result} = P_{\text{mea}} + A_{Rpl}$$

Limit:

Frequency of Emission(MHz)	Limits	
	Detector	Unit (dB μ V/m)
30~88	Quasi-peak	40
88~216	Quasi-peak	43.5
216~960	Quasi-peak	46
960~1000	Quasi-peak	54
1000~5th harmonic of the highest frequency or 40GHz, whichever is lower	Average	54
	Peak	74

Test result:
 EUT+Laptop

Frequency(MHz)	Result(dBuV/m)	ARpl (dB)	Pmea (dBuV/m)	Polarity
31.40	21.80	20.4	1.40	Vertical
165.73	26.82	10.7	16.12	Vertical
174.54	28.06	10.7	17.36	Vertical
479.95	32.72	20.9	11.82	Vertical
810.62	36.06	27.7	8.36	Horizontal
995.99	39.00	29.2	9.80	Vertical

EUT+Charger

Frequency(MHz)	Result(dBuV/m)	ARpl (dB)	Pmea (dBuV/m)	Polarity
30.841	30.57	20.7	9.87	Vertical
79.37	18.56	9.9	8.66	Vertical
98.03	18.19	11.9	6.29	Horizontal
497.59	24.87	21.2	3.67	Vertical
533.06	25.79	21.9	3.89	Vertical
927.85	33.35	28.3	5.05	Horizontal

EUT+Laptop:

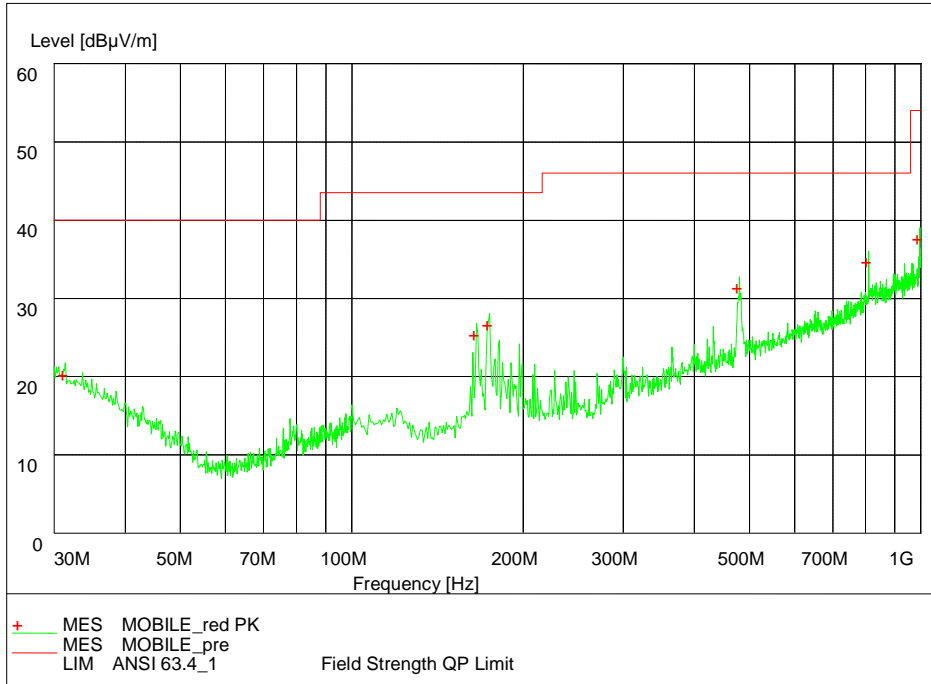

Pic6. Radiated emission (30MHz – 1GHz)

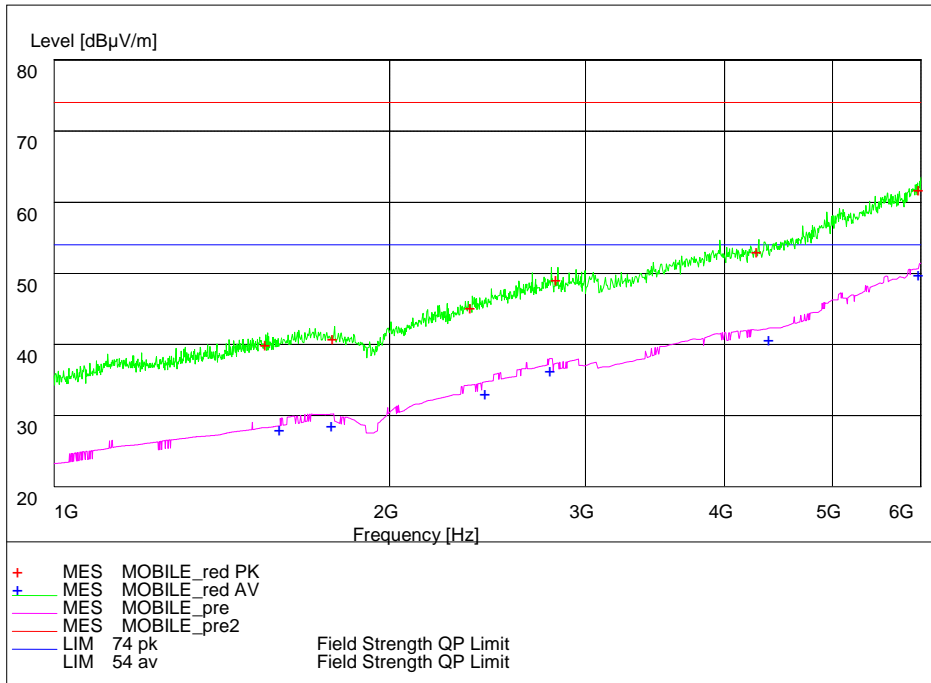

Pic7. Radiated emission (1GHz – 6GHz)

EUT+Charger::

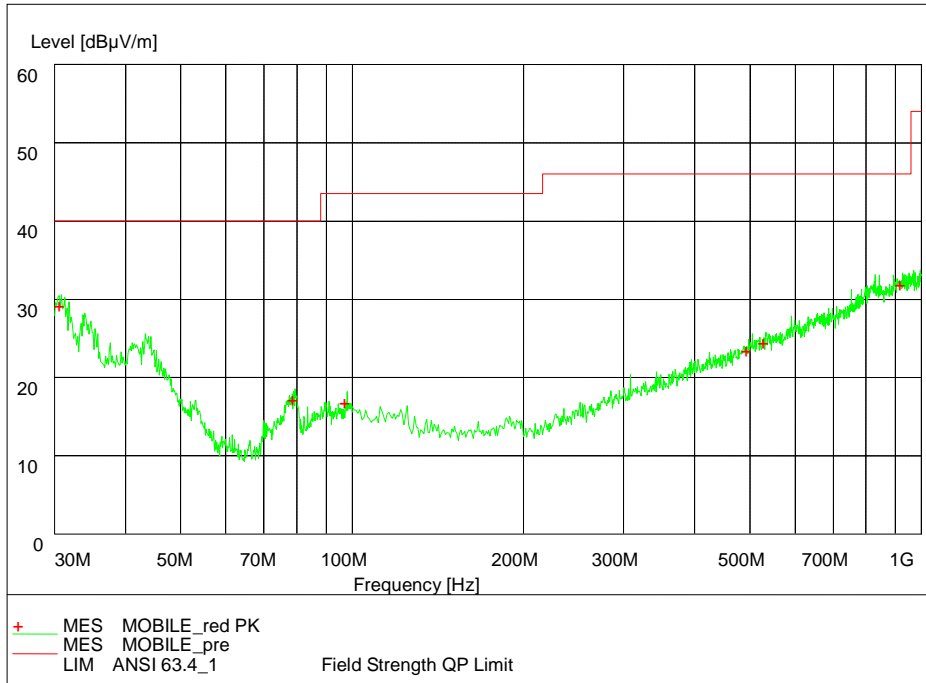

Pic8. Radiated emission (30MHz – 1GHz)

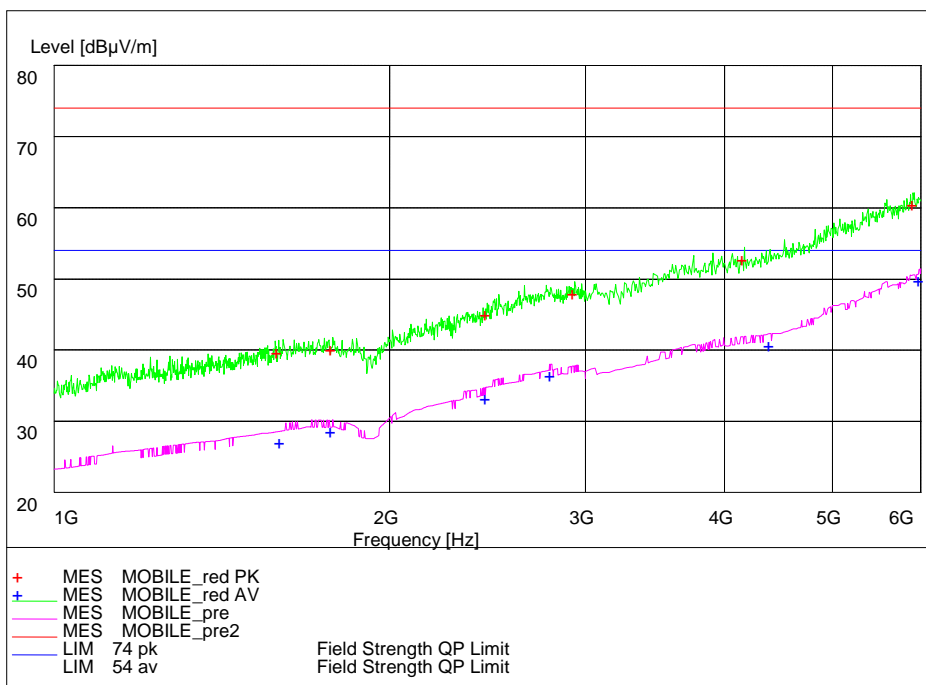

Pic9. Radiated emission (1GHz – 6GHz)

2.3. List of test equipments

No.	Name/Model	Manufacturer	S/N	Calibration Due Date
1	23.18m×16.88m×9.60m Semi-Anechoic Chamber	FRANKONIA	-----	20 th Aug. 2016
2	ESI 40 EMI test receiver	R&S	100015	20 th Aug. 2016
3	E5515C(8960) Mobile Station Tester	Agilent	GB44050904	20 th Aug. 2016
4	9.080m×5.255m×3.525m Shielding room	FRANKONIA	-----	20 th Aug. 2016
5	ESCS30 EMI test receiver	R&S	100029	20 th Aug. 2016
6	HL562 Ultra log test antenna	R&S	100016	20 th Aug. 2016
7	ESH3-Z2 Pulse limiter	R&S	10002	20 th Aug. 2016
8	LS16C AMN	AFJ	16011306281	20 th Aug. 2016
9	ESH2Z11 LISN	R&S	50FH-020-10	20 th Aug. 2016
10	HF 906 Double-Ridged Waveguide Horn Antenna	R&S	100030	20 th Aug. 2016
11	HF 906 Double-Ridged Waveguide Horn Antenna	R&S	100029	20 th Aug. 2016
12	PS2000 Turn Table	FRANKONIA	-----	20 th Aug. 2016
13	MA260 Antenna Master	FRANKONIA	-----	20 th Aug. 2016
14	ES-K1EMI test software	R&S	-----	20 th Aug. 2016
15	HL562 Receive antenna	R&S	100167	20 th Aug. 2016

Appendix

Appendix1 Test Setup