



TEST REPORT

APPLICANT : Shenzhen Sang Fei Consumer Communications Co.,Ltd
PRODUCT NAME : Feature Phone
MODEL NAME : Philips E108
BRAND NAME : Philips
FCC ID : VQRCTE108
STANDARD(S) : 47CFR 2.1093
IEEE 1528-2013
TEST DATE : 2018-10-22 to 2018-10-23
ISSUE DATE : 2018-10-27

Reviewed by : *Gan Yueming*
Gan Yueming(Reviewer)

Approved by: *Peng Huarui*
Peng Huarui (Supervisor)

NOTE: This document is issued by MORLAB, the test report shall not be reproduced except in full without prior written permission of the company. The test results apply only to the particular sample(s) tested and to the specific tests carried out which is available on request for validation and information confirmed at our website.



DIRECTORY

- 1. Technical Information5
 - 1.1. Applicant and Manufacturer Information5
 - 1.2. Equipment Under Test (EUT) Description5
 - 1.3. Summary of Maximum SAR Value6
 - 1.4. Photographs of the EUT7
 - 1.5. Applied Reference Documents7
- 2. RF Exposure Limits8
- 3. Specific Absorption Rate (SAR)9
 - 3.1. Introduction9
 - 3.2. SAR Definition9
- 4. SAR Measurement System10
 - 4.1. E-Field Probe11
 - 4.2. Data Acquisition Electronics (DAE)12
 - 4.3. Robot13
 - 4.4. Measurement Server13
 - 4.5. Phantom14
- 5. Device Holder15
 - 5.1. Data Storage and Evaluation16
- 6. Measurement Procedures19
 - 6.1. Spatial Peak SAR Evaluation19
 - 6.2. Power Reference Measurement20
 - 6.3. Area Scan20
 - 6.4. Zoom Scan21
 - 6.5. Volume Scan Procedures22
 - 6.6. Power Drift Monitoring22
- 7. Tissue Simulating Liquids23



8. Uncertainty Assessment25

9. SAR Measurement Evaluation28

9.1. Purpose of System Performance check28

9.2. System Setup28

9.3. Validation Results29

10. RF Exposure Positions30

10.1. Information on the testing30

10.2. Body-worn Configurations31

10.3. Hotspot Mode Exposure Position Conditions32

11. SAR Measurement Procedure33

11.1. General scan Requirements33

11.2. Measurement procedure34

11.3. Description of interpolation/extrapolation scheme34

11.4. Wireless Router35

12. SAR Measurement Evaluation36

13. Measurement of Conducted output power37

14. Test Results List38

15.1. Head SAR Evaluation40

15.2. Body-worn SAR Evaluation (Test distance 10mm)40

15. Simultaneous Transmission Evaluation41

Annex A General Information

Annex B Test Setup Photos

Annex C Plots of System Performance Check

Annex D Plots of Maximum SAR Test Results

Annex E DASY Calibration Certificate



| Change History | | |
|-----------------------|-------------|--------------------------|
| Issue | Date | Reason for change |
| 1.0 | 2018-10-27 | First edition |
| | | |
| | | |
| | | |
| | | |
| | | |
| | | |
| | | |
| | | |

| Tested By | |
|------------------|----------|
| Test engineer: | CHen Hao |



1. Technical Information

Note: Provide by applicant.

1.1. Applicant and Manufacturer Information

| | |
|------------------------------|---|
| Applicant: | Shenzhen Sang Fei Consumer Communications Co.,Ltd |
| Applicant Address: | 11 Science and Technology Road,Shenzhen Hi-tech Industrial Park Nanshan Distrcit,Shenzhen city,GuangDong province, 518057,China |
| Manufacturer: | Shenzhen Sang Fei Consumer Communications Co.,Ltd |
| Manufacturer Address: | 11 Science and Technology Road,Shenzhen Hi-tech Industrial Park Nanshan Distrcit,Shenzhen city,GuangDong province, 518057,China |

1.2. Equipment Under Test (EUT) Description

| | | | |
|----------------------------------|--|-----------|----------------------|
| EUT Type: | Feature Phone | | |
| Hardware Version: | 6186_MB_V2.1 | | |
| Software Version: | E108_M6186Z_201834_V01_SA | | |
| Frequency Bands: | GSM 850: 824.2 MHz ~ 848.8 MHz GSM 1900: 1850.2 MHz ~ 1909.8 MHz Bluetooth: 2402 MHz ~ 2480 MHz | | |
| Modulation Mode: | GSM/GPRS: GMSK Bluetooth: GFSK, $\pi/4$ -DQPSK, 8-DPSK | | |
| Multi-slot Class: | GPRS: Multi-slot Class 12; EDGE: Multi-slot Class 12; | | |
| Hotspot Mode: | Not Support | | |
| Antenna Type: | PIFA antenna | | |
| SIM Cards Description: | For dual SIM card version, SIM 1 and SIM 2 are the same chipset unit and tested as a single chipset, the SIM 1 was selected for test | | |
| Max Reported SAR-1g(W/Kg) | Head | 0.933W/kg | Limit(W/kg): 1.6W/kg |
| | Body-worn | 0.974W/kg | |

Note: For a more detailed description, please refer to specification or user's manual supplied by the applicant and/or manufacturer.



1.3. Summary of Maximum SAR Value

| Frequency Band | | Highest SAR Summary | |
|-----------------------------------|-----------|--------------------------|--------------------------------|
| | | Head (Separation 0mm) | Body-worn (Separation 10mm) |
| | | 1g SAR (W/kg) | |
| GSM | GSM850 | 0.933 | 0.974 |
| | GSM1900 | 0.371 | 0.390 |
| 2.4GHz Band | Bluetooth | N/A | N/A |
| Highest Simultaneous Transmission | | N/A | 1.203 |

Note:

This device is in compliance with Specific Absorption Rate (SAR) for general population/uncontrolled exposure limits (1.6W/kg as averaged over any 1 gram of tissue; specified in FCC 47 CFR part 2 (2.1093) and ANSI/IEEE C95.1-1992, and had been tested in accordance with the measurement methods and procedures specified in IEEE 1528-2013 and FCC KDB publications.



1.4. Photographs of the EUT

Please refer to the External Photos for the Photos of the EUT

1.5. Applied Reference Documents

Leading reference documents for testing:

| No. | Identity | Document Title |
|-----|-----------------------------|--|
| 1 | 47 CFR§2.1093 | Radiofrequency Radiation Exposure Evaluation: Portable Devices |
| 2 | IEEE 1528-2013 | IEEE Recommended Practice for Determining the Peak Spatial-Average Specific Absorption Rate (SAR) in the Human Head from Wireless Communications Devices: Measurement Techniques |
| 3 | KDB 447498 D01v06 | General RF Exposure Guidance |
| 4 | KDB 865664 D01v01r04 | SAR Measurement 100 MHz to 6 GHz |
| 5 | KDB 865664 D02v01r02 | RF Exposure Reporting |
| 6 | KDB 648474 D04v01r03 | Handset SAR |
| 7 | KDB 941225 D06v02r01 | SAR Evaluation Procedures For Portable Devices With Wireless Router Capabilities |



2. RF Exposure Limits

Uncontrolled Environment

Uncontrolled Environments are defined as locations where there is the exposure of individuals who have no knowledge or control of their exposure. The general population/uncontrolled exposure limits are applicable to situations in which the general public may be exposed or in which persons who are exposed as a consequence of their employment may not be made fully aware of the potential for exposure or cannot exercise control over their exposure. Members of the general public would come under this category when exposure is not employment-related; for example, in the case of a wireless transmitter that exposes persons in its vicinity.

Controlled Environment

Controlled Environments are defined as locations where there is exposure that may be incurred by persons who are aware of the potential for exposure, (i.e. as a result of employment or occupation). In general, occupational/controlled exposure limits are applicable to situations in which persons are exposed as a consequence of their employment, who have been made fully aware of the potential for exposure and can exercise control over their exposure. The exposure category is also applicable when the exposure is of a transient nature due to incidental passage through a location where the exposure levels may be higher than the general population/uncontrolled limits, but the exposed person is fully aware of the potential for exposure and can exercise control over his or her exposure by leaving the area or by some other appropriate means.

Limits for Occupational/Controlled Exposure (W/kg)

| Whole-Body | Partial-Body | Hands, Wrists, Feet and Ankles |
|------------|--------------|--------------------------------|
| 0.4 | 8.0 | 20.0 |

Limits for General Population/Uncontrolled Exposure (W/kg)

| Whole-Body | Partial-Body | Hands, Wrists, Feet and Ankles |
|------------|--------------|--------------------------------|
| 0.08 | 1.6 | 4.0 |

Whole-Body SAR is averaged over the entire body, partial-body SAR is averaged over any 1gram of tissue defined as a tissue volume in the shape of a cube. SAR for hands, wrists, feet and ankles is averaged over any 10 grams of tissue defined as a tissue volume in the shape of a cube.

3. Specific Absorption Rate (SAR)

3.1. Introduction

SAR is related to the rate at which energy is absorbed per unit mass in an object exposed to a radio field. The SAR distribution in a biological body is complicated and is usually carried out by experimental techniques or numerical modeling. The standard recommends limits for two tiers of groups, occupational/controlled and general population/uncontrolled, based on a person's awareness and ability to exercise control over his or her exposure. In general, occupational/controlled exposure limits are Middle than the limits for general population/uncontrolled.

3.2. SAR Definition

The SAR definition is the time derivative (rate) of the incremental energy (dW) absorbed by (dissipated in) an incremental mass (dm) contained in a volume element (dv) of a given density. (ρ). The equation description is as below:

$$SAR = \frac{d}{dt} \left(\frac{dW}{dm} \right) = \frac{d}{dt} \left(\frac{dW}{\rho dv} \right)$$

SAR is expressed in units of Watts per kilogram (W/kg)

SAR measurement can be either related to the temperature elevation in tissue by,

$$SAR = C \left(\frac{\delta T}{\delta t} \right)$$

Where C is the specific head capacity, δT is the temperature rise and δt the exposure duration, or related to the electrical field in the tissue by

$$SAR = \frac{\sigma |E|^2}{\rho}$$

Where σ is the conductivity of the tissue, ρ is the mass density of the tissue and |E| is the rms electrical field strength.

However for evaluating SAR of low power transmitter, electrical field measurement is typically applied.

4. SAR Measurement System

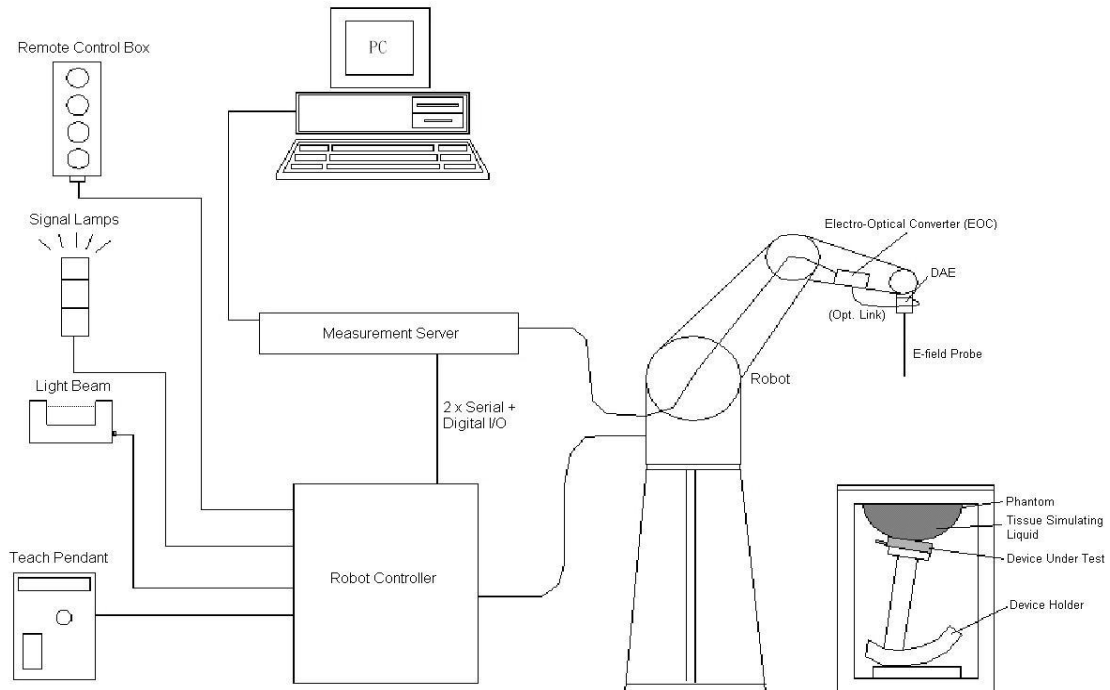

Fig 4.1 SPEAG DASY System Configurations

The DASY system for performance compliance tests is illustrated above graphically. This system consists of the following items:

A standard high precision 6-axis robot with controller, a teach pendant and software

A data acquisition electronic (DAE) attached to the robot arm extension

A dosimetric probe equipped with an optical surface detector system

The electro-optical converter (ECO) performs the conversion between optical and electrical signals

A measurement server performs the time critical tasks such as signal filtering, control of the robot operation and fast movement interrupts.

A probe alignment unit which improves the accuracy of the probe positioning

A computer operating Windows XP

DASY software

Remove control with teach pendant and additional circuitry for robot safety such as warning lamps, etc.

The SAM twin phantom

A device holder

Tissue simulating liquid

Dipole for evaluating the proper functioning of the system

Some of the components are described in details in the following sub-sections.

4.1. E-Field Probe

The SAR measurement is conducted with the dosimetric probe (manufactured by SPEAG). The probe is specially designed and calibrated for use in liquid with high permittivity. The dosimetric probe has special calibration in liquid at different frequency. This probe has a built in optical surface detection system to prevent from collision with phantom.

E-Field Probe Specification <ET3DV6 Probe >

| | | |
|----------------------|---|--|
| Construction | Symmetrical design with triangular core Built-in optical fiber for surface detection system. Built-in shielding against static charges. PEEK enclosure material (resistant to organic solvents, e.g., DGBE) |  |
| Frequency | 10 MHz to 3 GHz; Linearity: ± 0.2 dB | |
| Directivity | ± 0.2 dB in HSL (rotation around probe axis) ± 0.4 dB in HSL (rotation normal to probe axis) | |
| Dynamic Range | 5 μ W/g to 100 mW/g; Linearity: ± 0.2 dB | |
| Dimensions | Overall length: 330 mm (Tip: 16 mm) Tip diameter: 6.8 mm (Body: 12 mm) Distance from probe tip to dipole centers: 2.7 mm | |

Fig 4.2 Photo of ES3DV3

<EX3DV4 Probe>

| | | |
|----------------------|---|---|
| Construction | Symmetrical design with triangular core Built-in shielding against static charges PEEK enclosure material (resistant to organic solvents, e.g., DGBE) |  |
| Frequency | 10 MHz to 6 GHz; Linearity: ± 0.2 dB | |
| Directivity | ± 0.3 dB in HSL (rotation around probe axis) ± 0.5 dB in tissue material (rotation normal to probe axis) | |
| Dynamic Range | 10 μ W/g to 100 mW/g; Linearity: ± 0.2 dB | |
| Dimensions | Overall length: 330 mm (Tip: 20 mm) Tip diameter: 2.5 mm (Body: 12 mm) Typical distance from probe tip to dipole centers: 1 mm | |

Fig 4.3 Photo of EX3DV4

E-Field Probe Calibration

Each probe needs to be calibrated according to a dosimetric assessment procedure with accuracy better than $\pm 10\%$. The spherical isotropy shall be evaluated and within ± 0.25 dB. The sensitivity parameters (NormX, NormY, and NormZ), the diode compression parameter (DCP) and the conversion factor (ConvF) of the probe are tested. The calibration data can be referred to appendix C of this report.

4.2. Data Acquisition Electronics (DAE)

The data acquisition electronics(DAE) consists of a highly sensitive electrometer-grade preamplifier with auto-zeroing, a channel and gain-switching multiplexer, a fast 16 bit AD-converter and a command decoder and control logic unit. AD-converter and a command decoder and control logic unit. Transmission to the measurement server is accomplished through an optical downlink for data and status information as well as an optical uplink for commands and the clock. The input impedance of the DAE is 200 MOhm; the inputs are symmetrical and floating. Common mode rejection is above 80 dB.



Fig 4.4Photo of DAE

4.3. Robot

The SPEAG DASY system uses the high precision robots (DASY4: RX90BL; DASY5: TX90XL) type from Stäubli SA (France). For the 6-axis controller system, the robot controller version (DASY4: CS7MB; DASY5: CS8c) from Stäubli is used. The Stäubli robot series have many features that are important for our application:

High precision (repeatability ± 0.035 mm)

High reliability (industrial design)

Jerk-free straight movements

Low ELF interference (the closed metallic construction shields against motor control fields)



Fig 4.5 Photo of DASY5

4.4. Measurement Server

The measurement server is based on a PC/104 CPU board with CPU (DASY4: 166 MHz, Intel Pentium;

DASY5: 400 MHz, Intel Celeron), chip disk (DASY4: 32 MB; DASY5: 128 MB), RAM (DASY4: 64 MB, DASY5: 128 MB). The necessary circuits for communication with the DAE electronic box, as well as the 16 bit AD converter system for optical detection and digital I/O interface are contained on the DASY I/O board, which is directly connected to the PC/104 bus of the CPU board.

The measurement server performs all the real-time data evaluation for field measurements and surface detection, controls robot movements and handles safety operations.



Fig 4.6 Photo of Server for DASY5

4.5. Phantom

<SAM Twin Phantom>

| | |
|--------------------------|--|
| Shell Thickness | 2 ± 0.2 mm (sagging: <1%) Center ear point: 6 ± 0.2 mm |
| Filling Volume | Approx. 25 liters |
| Dimensions | Length: 1000 mm; Width: 500 mm; Height: adjustable feet |
| Measurement Areas | Left Hand, Right Hand, Flat Phantom |



Fig 4.7Photo of SAM Phantom

The bottom plate contains three pair of bolts for locking the device holder. The device holder positions are adjusted to the standard measurement positions in the three sections. A white cover is provided to tap the phantom during off-periods to prevent water evaporation and changes in the liquid parameters. On the phantom top, three reference markers are provided to identify the phantom position with respect to the robot.

5. Device Holder

<Device Holder for SAM Twin Phantom>

The SAR in the phantom is approximately inversely proportional to the square of the distance between the source and the liquid surface. For a source at 5 mm distance, a positioning uncertainty of ± 0.5 mm would produce a SAR uncertainty of ± 20 %. Accurate device positioning is therefore crucial for accurate and repeatable measurements. The positions in which the devices must be measured are defined by the standards.

The DASY device holder is designed to cope with different positions given in the standard. It has two scales for the device rotation (with respect to the body axis) and the device inclination (with respect to the line between the ear reference points). The rotation center for both scales is the ear reference point (EPR). Thus the device needs no repositioning when changing the angles.

The DASY device holder is constructed of low-loss POM material having the following dielectric parameters: relative permittivity $\epsilon = 3$ and loss tangent $\delta = 0.02$. The amount of dielectric material has been reduced in the closest vicinity of the device, since measurements have suggested that the influence of the clamp on the test results could thus be lowered.



Fig 5.1 Device Holder

<Laptop Extension Kit>

The extension is lightweight and made of POM, acrylic glass and foam. It fits easily on the upper part of the mounting device in place of the phone positioned. The extension is fully compatible with the SAM Twin and ELI phantoms.

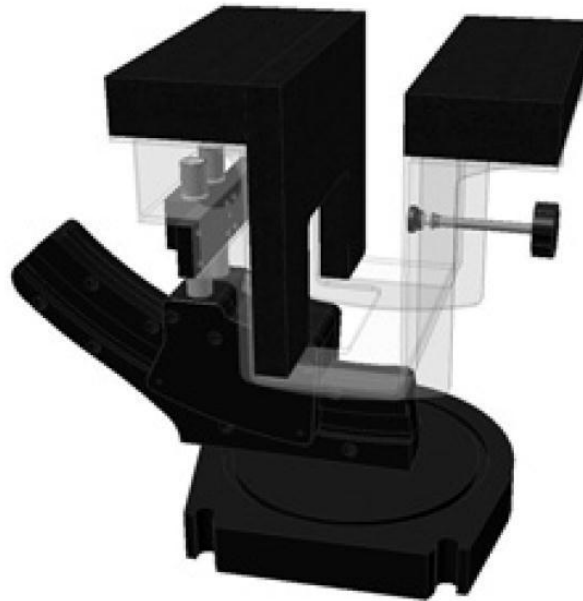

Fig 5.2 Laptop Extension Kit

5.1. Data Storage and Evaluation

Data Storage

The DASY software stores the assessed data from the data acquisition electronics as raw data (in microvolt readings from the probe sensors), together with all the necessary software parameters for the data evaluation (probe calibration data, liquid parameters and device frequency and modulation data) in measurement files. The post-processing software evaluates the desired unit and format for output each time the data is visualized or exported. This allows verification of the complete software setup even after the measurement and allows correction of erroneous parameter settings. For example, if a measurement has been performed with an incorrect crest factor parameter in the device setup, the parameter can be corrected afterwards and the data can be reevaluated.

The measured data can be visualized or exported in different units or formats, depending on the selected probe type (e.g., [V/m], [A/m], [mW/g]). Some of these units are not available in certain situations or give meaningless results, e.g., a SAR-output in a non-loss media, will always be zero. Raw data can also be exported to perform the evaluation with other software packages.

**Data Evaluation**

The DASY post-processing software (SEMCAD) automatically executes the following procedures to calculate the field units from the microvolt readings at the probe connector. The parameters used in the evaluation are stored in the configuration modules of the software.

| | | |
|---------------------------|---------------------------|---|
| Probe parameters: | - Sensitivity | Norm _i , a _{i0} , a _{i1} , a _{i2} |
| | - Conversion factor | ConvF _i |
| | - Diode compression point | dcpi |
| Device parameters: | - Frequency | f |
| | - Crest factor | cf |
| Media parameters: | - Conductivity | σ |
| | - Density | ρ |

These parameters must be set correctly in the software. They can be found in the component documents or they can be imported into the software from the configuration files issued for the DASY components. In the direct measuring mode of the multi-meter option, the parameters of the actual system setup are used. In the scan visualization and export modes, the parameters stored in the corresponding document files are used.

The first step of the evaluation is a linearization of the filtered input signal to account for the compression characteristics of the detector diode. The compensation depends on the input signal, the diode type and the DC-transmission factor from the diode to the evaluation electronics. If the exciting field is pulsed, the crest factor of the signal must be known to correctly compensate for peak power.

The formula for each channel can be given as:

$$V_i = U_i + U_i^2 \times \frac{cf}{dcp_i}$$

With
 V_i = compensated signal of channel i , ($i = x, y, z$)
 U_i = input signal of channel i , ($i = x, y, z$)
 cf = crest factor of exciting field (DASY parameter)
 dcp_i = diode compression point (DASY parameter)

From the compensated input signals, the primary field data for each channel can be evaluated:

$$\text{E-field Probes: } E_i = \sqrt{\frac{V_i}{\text{Norm}_i \times \text{ConvF}}}$$

$$\text{H-field Probes: } H_i = \sqrt{V_i} \times \frac{a_{i0} + a_{i1} + a_{i2}f^2}{f}$$



With V_i = compensated signal of channel i , ($i = x, y, z$)
Norm $_i$ = sensor sensitivity of channel i , ($i = x, y, z$), $\mu V/(V/m)^2$ for E-field
Probes ConvF = sensitivity enhancement in solution
 a_{ij} = sensor sensitivity factors for H-field probes
 f = carrier frequency [GHz]
 E_i = electric field strength of channel i in V/m
 H_i = magnetic field strength of channel i in A/m

The RSS value of the field components gives the total field strength (Hermitian magnitude):

$$E_{\text{tot}} = \sqrt{E_x^2 + E_y^2 + E_z^2}$$

The primary field data are used to calculate the derived field units.

$$SAR = E_{\text{tot}}^2 \times \frac{\sigma}{\rho \times 1000}$$

with SAR = local specific absorption rate in mW/g
 E_{tot} = total field strength in V/m
 σ = conductivity in [mho/m] or [Siemens/m]
 ρ = equivalent tissue density in g/cm^3

Note that the density is set to 1, to account for actual head tissue density rather than the density of the tissue simulating liquid.

6. Measurement Procedures

The measurement procedures are as follows:

<Conducted power measurement>

- (a) For WWAN power measurement, use base station simulator to configure EUT WWAN transmission in conducted connection with RF cable, at maximum power in each supported wireless interface and frequency band.
- (b) Read the WWAN RF power level from the base station simulator.
- (c) For WLAN/BT power measurement, use engineering software to configure EUT WLAN/BT continuously transmission, at maximum RF power in each supported wireless interface and frequency band

Connect EUT RF port through RF cable to the power meter, and measure WLAN/BT output power

<SAR measurement>

- (a) Use base station simulator to configure EUT WWAN transmission in radiated connection, and engineering software to configure EUT WLAN/BT continuously transmission, at maximum RF power, in the highest power channel
- (b) Place the EUT in the positions as Appendix D demonstrates.
- (c) Set scan area, grid size and other setting on the DASY software.
- (d) Measure SAR results for the highest power channel on each testing position.
- (e) Find out the largest SAR result on these testing positions of each band
- (f) Measure SAR results for other channels in worst SAR testing position if the reported SAR of highest power channel is larger than 0.8 W/kg

According to the test standard, the recommended procedure for assessing the peak spatial-average SAR value consists of the following steps:

- (a) Power reference measurement
- (b) Area scan
- (c) Zoom scan
- (d) Power drift measurement

6.1. Spatial Peak SAR Evaluation

The procedure for spatial peak SAR evaluation has been implemented according to the test standard. It can be conducted for 1g and 10g, as well as for user-specific masses. The DASY software includes all numerical procedures necessary to evaluate the spatial peak SAR value. The base for the evaluation is a "cube" measurement. The measured volume must include the 1g and 10g cubes with the highest averaged SAR values. For that purpose, the center of the measured volume is aligned to the interpolated peak SAR value of a previously performed area scan.



The entire evaluation of the spatial peak values is performed within the post-processing engine (SEMCAD). The system always gives the maximum values for the 1g and 10g cubes. The algorithm to find the cube with highest averaged SAR is divided into the following stages:

- (a) Extraction of the measured data (grid and values) from the Zoom Scan
- (b) Calculation of the SAR value at every measurement point based on all stored data (A/D values and measurement parameters)
- (c) Generation of a high-resolution mesh within the measured volume
- (d) Interpolation of all measured values from the measurement grid to the high-resolution grid
- (e) Extrapolation of the entire 3-D field distribution to the phantom surface over the distance from sensor to surface
- (f) Calculation of the averaged SAR within masses of 1g and 10g

6.2. Power Reference Measurement

The Power Reference Measurement and Power Drift Measurements are for monitoring the power drift of the device under test in the batch process. The minimum distance of probe sensors to surface determines the closest measurement point to phantom surface. This distance cannot be smaller than the distance of sensor calibration points to probe tip as defined in the probe properties.

6.3. Area Scan

The area scan is used as a fast scan in two dimensions to find the area of high field values, before doing a fine measurement around the hot spot. The sophisticated interpolation routines implemented in DASY software can find the maximum found in the scanned area, within a range of the global maximum. The range (in dB₀) is specified in the standards for compliance testing. For example, a 2 dB range is required in IEEE standard 1528 and IEC 62209 standards, whereby 3 dB is a requirement when compliance is assessed in accordance with the ARIB standard (Japan), if only one zoom scan follows the area scan, then only the absolute maximum will be taken as reference. For cases where multiple maximums are detected, the number of zoom scans has to be increased accordingly.

Area scan parameters extracted from FCC KDB 865664 D01v01r04 SAR measurement 100 MHz to 6 GHz.

| | ≤ 3 GHz | > 3 GHz |
|--|--|--|
| Maximum distance from closest measurement point (geometric center of probe sensors) to phantom surface | 5 ± 1 mm | $\frac{1}{2} \cdot \delta \cdot \ln(2) \pm 0.5$ mm |
| Maximum probe angle from probe axis to phantom surface normal at the measurement location | $30^\circ \pm 1^\circ$ | $20^\circ \pm 1^\circ$ |
| Maximum area scan spatial resolution: Δx_{Area} , Δy_{Area} | ≤ 2 GHz: ≤ 15 mm 2 – 3 GHz: ≤ 12 mm | 3 – 4 GHz: ≤ 12 mm 4 – 6 GHz: ≤ 10 mm |
| | When the x or y dimension of the test device, in the measurement plane orientation, is smaller than the above, the measurement resolution must be \leq the corresponding x or y dimension of the test device with at least one measurement point on the test device. | |

6.4.Zoom Scan

Zoom scans are used assess the peak spatial SAR values within a cubic averaging volume containing 1 gram and 10 gram of simulated tissue. The zoom scan measures points (refer to table below) within a cube shoes base faces are centered on the maxima found in a preceding area scan job within the same procedure. When the measurement is done, the zoom scan evaluates the averaged SAR for 1 gram and 10 gram and displays these values next to the job's label.

Zoom scan parameters extracted from FCC KDB 865664 D01v01r04 SAR measurement 100 MHz to 6 GHz

| | | ≤ 3 GHz | > 3 GHz | |
|--|------------------------------------|--|---|--|
| Maximum zoom scan spatial resolution: Δx_{Zoom} , Δy_{Zoom} | | ≤ 2 GHz: ≤ 8 mm 2 – 3 GHz: ≤ 5 mm* | 3 – 4 GHz: ≤ 5 mm* 4 – 6 GHz: ≤ 4 mm* | |
| Maximum zoom scan spatial resolution, normal to phantom surface | uniform grid: $\Delta z_{Zoom}(n)$ | ≤ 5 mm | 3 – 4 GHz: ≤ 4 mm 4 – 5 GHz: ≤ 3 mm 5 – 6 GHz: ≤ 2 mm | |
| | graded grid | $\Delta z_{Zoom}(1)$: between 1 st two points closest to phantom surface | ≤ 4 mm | 3 – 4 GHz: ≤ 3 mm 4 – 5 GHz: ≤ 2.5 mm 5 – 6 GHz: ≤ 2 mm |
| | | $\Delta z_{Zoom}(n>1)$: between subsequent points | $\leq 1.5 \cdot \Delta z_{Zoom}(n-1)$ | |
| Minimum zoom scan volume | x, y, z | ≥ 30 mm | 3 – 4 GHz: ≥ 28 mm 4 – 5 GHz: ≥ 25 mm 5 – 6 GHz: ≥ 22 mm | |
| Note: δ is the penetration depth of a plane-wave at normal incidence to the tissue medium; see draft standard IEEE P1528-2011 for details. * When zoom scan is required and the reported SAR from the area scan based 1-g SAR estimation procedures of KDB 447498 is ≤ 1.4 W/kg, ≤ 8 mm, ≤ 7 mm and ≤ 5 mm zoom scan resolution may be applied, respectively, for 2 GHz to 3 GHz, 3 GHz to 4 GHz and 4 GHz to 6 GHz. | | | | |



6.5. Volume Scan Procedures

The volume scan is used for assess overlapping SAR distributions for antennas transmitting in different frequency bands. It is equivalent to an oversized zoom scan used in standalone measurements. The measurement volume will be used to enclose all the simultaneous transmitting antennas. For antennas transmitting simultaneously in different frequency bands, the volume scan is measured separately in each frequency band. In order to sum correctly to compute the 1g aggregate SAR, the EUT remain in the same test position for all measurements and all volume scan use the same spatial resolution and grid spacing. When all volume scan were completed, the software, SEMCAD postprocessor can combine and subsequently superpose these measurement data to calculating the multiband SAR.

6.6. Power Drift Monitoring

All SAR testing is under the EUT install full charged battery and transmit maximum output power. In DASY measurement software, the power reference measurement and power drift measurement procedures are used for monitoring the power drift of EUT during SAR test. Both these procedures measure the field at a specified reference position before and after the SAR testing. The software will calculate the field difference in dB. If the power drifts more than 5%, the SAR will be retested.

7. Tissue Simulating Liquids

For SAR measurement of the field distribution inside the phantom, the phantom must be filled with homogeneous tissue simulating liquid to a depth of at least 15 cm. For head SAR testing, the liquid height from the ear reference point (ERP) of the phantom to the liquid top surface is larger than 15 cm. For body SAR testing, the liquid height from the center of the flat phantom to the liquid top surface is larger than 15 cm, which is shown in Fig. 5.1. For body SAR testing, the liquid height from the center of the flat phantom to the liquid top surface is larger than 15 cm, which is shown in Fig. 5.2. The nominal dielectric values of the tissue simulating liquids in the phantom and the tolerance of 5% are listed in below table.

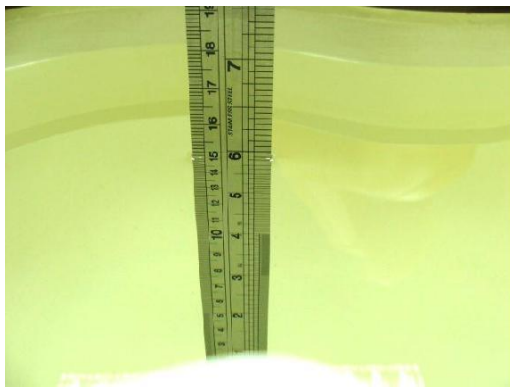

Fig 7.1 Photo of Liquid Height for Head SAR

Fig 7.2 Photo of Liquid Height for Body SAR

The following table gives the recipes for tissue simulating liquids

| Frequency (MHz) | Water (%) | Sugar (%) | Cellulose (%) | Salt (%) | Preventol (%) | DGBE (%) | Conductivity (σ) | Permittivity (ϵ_r) |
|------------------|-----------|-----------|---------------|----------|---------------|----------|---------------------------|-------------------------------|
| Head | | | | | | | | |
| 750 | 41.1 | 57.0 | 0.2 | 1.4 | 0.2 | 0 | 0.89 | 41.9 |
| 835 | 40.3 | 57.9 | 0.2 | 1.4 | 0.2 | 0 | 0.90 | 41.5 |
| 1800, 1900, 2000 | 55.2 | 0 | 0 | 0.3 | 0 | 44.5 | 1.40 | 40.0 |
| 2450 | 55.0 | 0 | 0 | 0 | 0 | 45.0 | 1.80 | 39.2 |
| 2600 | 54.8 | 0 | 0 | 0.1 | 0 | 45.1 | 1.96 | 39.0 |
| Body | | | | | | | | |
| 750 | 51.7 | 47.2 | 0 | 0.9 | 0.1 | 0 | 0.96 | 55.5 |
| 835 | 50.8 | 48.2 | 0 | 0.9 | 0.1 | 0 | 0.97 | 55.2 |
| 1800, 1900, 2000 | 70.2 | 0 | 0 | 0.4 | 0 | 29.4 | 1.52 | 53.3 |
| 2450 | 68.6 | 0 | 0 | 0 | 0 | 31.4 | 1.95 | 52.7 |
| 2600 | 68.1 | 0 | 0 | 0.1 | 0 | 31.8 | 2.16 | 52.5 |



Simulating Liquid for 5GHz, Manufactured by SPEAG

| Ingredients | (% by weight) |
|--------------------|---------------|
| Water | 64~78% |
| Mineral oil | 11~18% |
| Emulsifiers | 9~15% |
| Additives and Salt | 2~3% |

Note: Please refer to the validation results for dielectric parameters of each frequency band.

The dielectric properties of the tissue simulating liquids were verified prior to the SAR evaluation using an Agilent 85033E Dielectric Probe Kit and an Agilent Network Analyzer.

Table 1: Dielectric Performance of Tissue Simulating Liquid

| Frequency (MHz) | Tissue Type | Liquid Temp. (°C) | Conductivity (σ) | Conductivity Target (σ) | Delta (σ) (%) | Limit (%) | Date |
|-----------------|-------------|-------------------|------------------|-------------------------|---------------|-----------|------------|
| 835 | HSL | 22.6 | 0.891 | 0.90 | -1.00 | ±5 | 2018.10.23 |
| 1900 | HSL | 22.2 | 1.420 | 1.40 | 1.43 | ±5 | 2018.10.22 |
| | | | | | | | |
| 835 | MSL | 22.5 | 0.943 | 0.97 | -2.78 | ±5 | 2018.10.23 |
| 1900 | MSL | 22.7 | 1.532 | 1.52 | 0.79 | ±5 | 2018.10.22 |

| Frequency (MHz) | Tissue Type | Liquid Temp. (°C) | Permittivity (ε _r) | Permittivity Target (ε _r) | Delta (ε _r) (%) | Limit (%) | Date |
|-----------------|-------------|-------------------|--------------------------------|---------------------------------------|-----------------------------|-----------|------------|
| 835 | HSL | 22.6 | 41.762 | 41.50 | 0.63 | ±5 | 2018.10.23 |
| 1900 | HSL | 22.2 | 40.886 | 40.00 | 2.22 | ±5 | 2018.10.22 |
| | | | | | | | |
| 835 | MSL | 22.5 | 54.341 | 55.20 | -1.56 | ±5 | 2018.10.23 |
| 1900 | MSL | 22.7 | 52.393 | 53.30 | -1.70 | ±5 | 2018.10.22 |

8. Uncertainty Assessment

The component of uncertainty may generally be categorized according to the methods used to evaluate them. The evaluation of uncertainty by the statistical analysis of a series of observations is termed a Type A evaluation of uncertainty. The evaluation of uncertainty by means other than the statistical analysis of a series of observation is termed a Type B evaluation of uncertainty. Each component of uncertainty, however evaluated, is represented by an estimated standard deviation, termed standard uncertainty, which is determined by the positive square root of the estimated variance.

A Type A evaluation of standard uncertainty may be based on any valid statistical method for treating data. This includes calculating the standard deviation of the mean of a series of independent observations; using the method of least squares to fit a curve to the data in order to estimate the parameter of the curve and their standard deviations; or carrying out an analysis of variance in order to identify and quantify random effects in certain kinds of measurement.

A type B evaluation of standard uncertainty is typically based on scientific judgment using all of the relevant information available. These may include previous measurement data, experience, and knowledge of the behavior and properties of relevant materials and instruments, manufacture's specification, data provided in calibration reports and uncertainties assigned to reference data taken from handbooks. Broadly speaking, the uncertainty is either obtained from an outdoor source or obtained from an assumed distribution, such as the normal distribution, rectangular or triangular distributions indicated in table below.

| Uncertainty | Normal | Rectangular | Triangular | U-Shape |
|------------------------------------|-------------|--------------|--------------|--------------|
| Multi-plying Factor ^(a) | $1/k^{(b)}$ | $1/\sqrt{3}$ | $1/\sqrt{6}$ | $1/\sqrt{2}$ |

Table 8.1. Standard Uncertainty for Assumed Distribution

(a) standard uncertainty is determined as the product of the multiplying factor and the estimated range of variations in the measured quantity

(b) k is the coverage factor

The combined standard uncertainty of the measurement result represents the estimated standard deviation of the result. It is obtained by combining the individual standard uncertainties of both Type A and Type B evaluation using the usual "root-sum-squares" (RSS) methods of combining standard deviations by taking the positive square root of the estimated variances.

Expanded uncertainty is a measure of uncertainty that defines an interval about the measurement result within which the measured value is confidently believed to lie. It is obtained by multiplying the combined standard uncertainty by a coverage factor. Typically, the coverage factor ranges from 2 to 3. Using a coverage factor allows the true value of a measured quantity to be specified with a



defined probability within the specified uncertainty range. For purpose of this document, a coverage factor two is used, which corresponds to confidence interval of about 95 %. The DASy uncertainty Budget is shown in the following tables.

| Error Description | Uncertainty Value (±%) | Probability | Divisor | (Ci) 1g | (Ci) 10g | Standard Uncertainty (1g) (±%) | Standard Uncertainty (10g) (±%) |
|-----------------------------------|------------------------|-------------|---------|---------|----------|--------------------------------|---------------------------------|
| Measurement System | | | | | | | |
| Probe Calibration | 6.0 | N | 1 | 1 | 1 | 6.0 | 6.0 |
| Axial Isotropy | 4.7 | R | 1.732 | 0.7 | 0.7 | 1.9 | 1.9 |
| Hemispherical Isotropy | 9.6 | R | 1.732 | 0.7 | 0.7 | 3.9 | 3.9 |
| Boundary Effects | 1.0 | R | 1.732 | 1 | 1 | 0.6 | 0.6 |
| Linearity | 4.7 | R | 1.732 | 1 | 1 | 2.7 | 2.7 |
| System Detection Limits | 1.0 | R | 1.732 | 1 | 1 | 0.6 | 0.6 |
| Modulation Response | 3.2 | R | 1.732 | 1 | 1 | 1.8 | 1.8 |
| Readout Electronics | 0.3 | N | 1 | 1 | 1 | 0.3 | 0.3 |
| Response Time | 0.0 | R | 1.732 | 1 | 1 | 0.0 | 0.0 |
| Integration Time | 2.6 | R | 1.732 | 1 | 1 | 1.5 | 1.5 |
| RF Ambient Noise | 3.0 | R | 1.732 | 1 | 1 | 1.7 | 1.7 |
| RF Ambient Reflections | 3.0 | R | 1.732 | 1 | 1 | 1.7 | 1.7 |
| Probe Positioner | 0.4 | R | 1.732 | 1 | 1 | 0.2 | 0.2 |
| Probe Positioning | 2.9 | R | 1.732 | 1 | 1 | 1.7 | 1.7 |
| Max. SAR Eval. | 2.0 | R | 1.732 | 1 | 1 | 1.2 | 1.2 |
| Test Sample Related | | | | | | | |
| Device Positioning | 3.0 | N | 1 | 1 | 1 | 3.0 | 3.0 |
| Device Holder | 3.6 | N | 1 | 1 | 1 | 0.089 | 0.089 |
| Power Drift | 5.0 | R | 1.732 | 1 | 1 | 2.9 | 2.9 |
| Power Scaling | 0.0 | R | 1.732 | 1 | 1 | 0.0 | 0.0 |
| Phantom and Setup | | | | | | | |
| Phantom Uncertainty | 6.1 | R | 1.732 | 1 | 1 | 3.5 | 3.5 |
| SAR correction | 0.0 | R | 1.732 | 1 | 0.84 | 0.0 | 0.0 |
| Liquid Conductivity Repeatability | 0.2 | N | 1 | 0.78 | 0.71 | 0.1 | 0.1 |
| Liquid Conductivity (target) | 5.0 | R | 1.732 | 0.78 | 0.71 | 2.3 | 2.0 |
| Liquid Conductivity (mea.) | 2.5 | R | 1.732 | 0.78 | 0.71 | 1.1 | 1.0 |
| Temp. unc. - Conductivity | 3.4 | R | 1.732 | 0.78 | 0.71 | 1.5 | 1.4 |
| Liquid Permittivity Repeatability | 0.15 | N | 1 | 0.23 | 0.26 | 0.0 | 0.0 |
| Liquid Permittivity (target) | 5.0 | R | 1.732 | 0.23 | 0.26 | 0.7 | 0.8 |
| Liquid Permittivity (mea.) | 2.5 | R | 1.732 | 0.23 | 0.26 | 0.3 | 0.4 |
| Temp. unc. - Permittivity | 0.83 | R | 1.732 | 0.23 | 0.26 | 0.1 | 0.1 |
| Combined Std. Uncertainty | | | | | | 11.4% | 11.4% |
| Coverage Factor for 95 % | | | | | | K=2 | K=2 |
| Expanded STD Uncertainty | | | | | | 22.9% | 22.7% |



| Error Description | Uncertainty Value (±%) | Probability | Divisor | (Ci) 1g | (Ci) 10g | Standard Uncertainty (1g) (±%) | Standard Uncertainty (10g) (±%) |
|-----------------------------------|------------------------|-------------|---------|---------|----------|--------------------------------|---------------------------------|
| Measurement System | | | | | | | |
| Probe Calibration | 6.55 | N | 1 | 1 | 1 | 6.0 | 6.0 |
| Axial Isotropy | 4.7 | R | 1.732 | 0.7 | 0.7 | 1.9 | 1.9 |
| Hemispherical Isotropy | 9.6 | R | 1.732 | 0.7 | 0.7 | 3.9 | 3.9 |
| Boundary Effects | 2.0 | R | 1.732 | 1 | 1 | 1.2 | 1.2 |
| Linearity | 4.7 | R | 1.732 | 1 | 1 | 2.7 | 2.7 |
| System Detection Limits | 1.0 | R | 1.732 | 1 | 1 | 0.6 | 0.6 |
| Modulation Response | 3.2 | R | 1.732 | 1 | 1 | 1.8 | 1.8 |
| Readout Electronics | 0.3 | N | 1 | 1 | 1 | 0.3 | 0.3 |
| Response Time | 0.0 | R | 1.732 | 1 | 1 | 0.0 | 0.0 |
| Integration Time | 2.6 | R | 1.732 | 1 | 1 | 1.5 | 1.5 |
| RF Ambient Noise | 3.0 | R | 1.732 | 1 | 1 | 1.7 | 1.7 |
| RF Ambient Reflections | 3.0 | R | 1.732 | 1 | 1 | 1.7 | 1.7 |
| Probe Positioner | 0.4 | R | 1.732 | 1 | 1 | 0.2 | 0.2 |
| Probe Positioning | 6.7 | R | 1.732 | 1 | 1 | 3.9 | 3.9 |
| Max. SAR Eval. | 4.0 | R | 1.732 | 1 | 1 | 2.3 | 2.3 |
| Test Sample Related | | | | | | | |
| Device Positioning | 3.0 | N | 1 | 1 | 1 | 3.0 | 3.0 |
| Device Holder | 3.6 | N | 1 | 1 | 1 | 0.089 | 0.089 |
| Power Drift | 5.0 | R | 1.732 | 1 | 1 | 2.9 | 2.9 |
| Power Scaling | 0.0 | R | 1.732 | 1 | 1 | 0.0 | 0.0 |
| Phantom and Setup | | | | | | | |
| Phantom Uncertainty | 6.1 | R | 1.732 | 1 | 1 | 3.8 | 3.8 |
| SAR correction | 0.0 | R | 1.732 | 1 | 0.84 | 0.0 | 0.0 |
| Liquid Conductivity Repeatability | 0.2 | N | 1 | 0.78 | 0.71 | 0.1 | 0.1 |
| Liquid Conductivity (target) | 5.0 | R | 1.732 | 0.78 | 0.71 | 2.3 | 2.0 |
| Liquid Conductivity (mea.) | 2.5 | R | 1.732 | 0.78 | 0.71 | 1.1 | 1.0 |
| Temp. unc. - Conductivity | 3.4 | R | 1.732 | 0.78 | 0.71 | 1.5 | 1.4 |
| Liquid Permittivity Repeatability | 0.15 | N | 1 | 0.23 | 0.26 | 0.0 | 0.0 |
| Liquid Permittivity (target) | 5.0 | R | 1.732 | 0.23 | 0.26 | 0.7 | 0.8 |
| Liquid Permittivity (mea.) | 2.5 | R | 1.732 | 0.23 | 0.26 | 0.3 | 0.4 |
| Temp. unc. - Permittivity | 0.83 | R | 1.732 | 0.23 | 0.26 | 0.1 | 0.1 |
| Combined Std. Uncertainty | | | | | | 12.5% | 12.5% |
| Coverage Factor for 95 % | | | | | | K=2 | K=2 |
| Expanded STD Uncertainty | | | | | | 25.1 % | 25.1% |

9. SAR Measurement Evaluation

Each DASY system is equipped with one or more system validation kits. These units, together with the predefined measurement procedures within the DASY software, enable the user to conduct the system performance check and system validation. System validation kit includes a dipole, tripod holder to fix it underneath the flat phantom and a corresponding distance holder.

9.1. Purpose of System Performance check

The system performance check verifies that the system operates within its specifications. System and operator errors can be detected and corrected. It is recommended that the system performance check be performed prior to any usage of the system in order to guarantee reproducible results. The system performance check uses normal SAR measurements in a simplified setup with a well characterized source. This setup was selected to give a high sensitivity to all parameters that might fail or vary over time. The system check does not intend to replace the calibration of the components, but indicates situations where the system uncertainty is exceeded due to drift or failure.

9.2. System Setup

The output power on dipole port must be calibrated to 24 dBm (250 mW) before dipole is connected. In the simplified setup for system evaluation, the DUT is replaced by a calibrated dipole and the power source is replaced by a continuous wave which comes from a signal generator. The calibrated dipole must be placed beneath the flat phantom section of the SAM twin phantom with the correct distance holder. The distance holder should touch the phantom surface with a light pressure at the reference marking and be oriented parallel to the long side of the phantom. The system check verifies that the system operates within its specifications. It is performed daily or before every SAR measurement. The system check uses normal SAR measurements in the flat section of the phantom with a matched dipole at a specified distance. The system verification setup is shown as below.

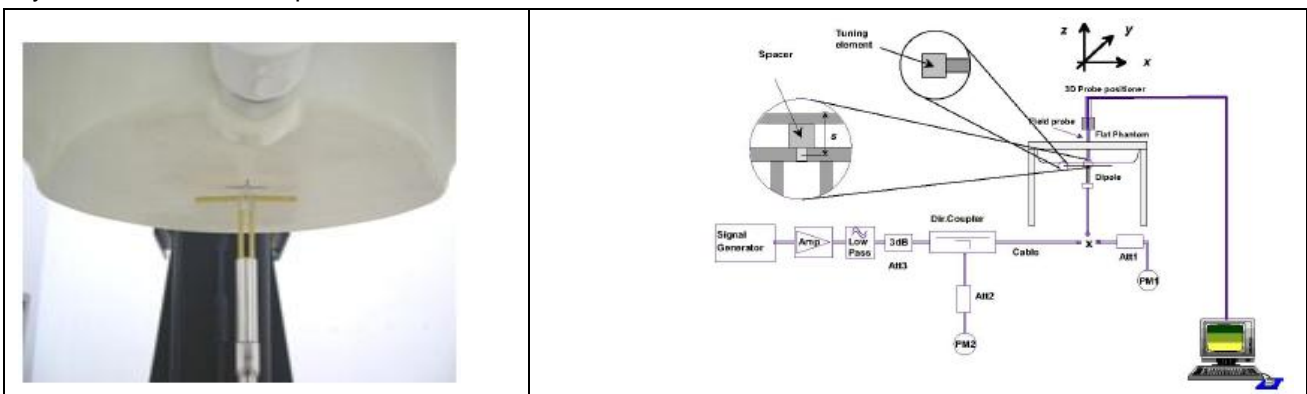

Fig 9.1 Photo of Dipole Setup

Fig 9.2 System Setup for System Evaluation

9.3. Validation Results

After system check testing, the SAR result will be normalized to 1W forward input power and compared with the reference SAR value derived from validation dipole certificate report. The deviation of system check should be within 10 %.

<Validation Setup>

| Frequency (MHz) | Tissue Type | Input Power (mW) | Dipole S/N | Probe S/N | DAE S/N |
|-----------------|-------------|------------------|---------------|-----------|---------|
| 835 | HSL | 250 | D835V2-4d227 | SN7445 | 1516 |
| 1900 | HSL | 250 | D1900V2_5d221 | SN7445 | 1516 |
| 835 | MSL | 250 | D835V2-4d227 | SN7445 | 1516 |
| 1900 | MSL | 250 | D1900V2_5d221 | SN7445 | 1516 |

<1g SAR>

| Date | Frequency (MHz) | Tissue Type | Input Power (mW) | Measured 1g SAR (W/kg) | Targeted 1g SAR (W/kg) | Normalized 1g SAR (W/kg) | Deviation (%) |
|------------|-----------------|-------------|------------------|------------------------|------------------------|--------------------------|---------------|
| 2018.10.23 | 835 | HSL | 250 | 2.46 | 9.46 | 9.84 | 4.02 |
| 2018.10.22 | 1900 | HSL | 250 | 10.25 | 39.30 | 41 | 4.33 |
| 2018.10.23 | 835 | MSL | 250 | 2.37 | 9.56 | 9.48 | -0.84 |
| 2018.10.22 | 1900 | MSL | 250 | 9.91 | 40.40 | 39.64 | -1.88 |

<10g SAR>

| Date | Frequency (MHz) | Tissue Type | Input Power (mW) | Measured 10g SAR (W/kg) | Targeted 10g SAR (W/kg) | Normalized 10g SAR (W/kg) | Deviation (%) |
|------------|-----------------|-------------|------------------|-------------------------|-------------------------|---------------------------|---------------|
| 2018.10.23 | 835 | HSL | 250 | 1.58 | 6.11 | 6.32 | 3.44 |
| 2018.10.22 | 1900 | HSL | 250 | 5.27 | 20.50 | 21.08 | 2.83 |
| 2018.10.23 | 835 | MSL | 250 | 1.53 | 6.28 | 6.12 | -2.55 |
| 2018.10.22 | 1900 | MSL | 250 | 5.51 | 21.30 | 22.04 | 3.47 |

Note: System checks the specific test data please see Annex C

10. RF Exposure Positions

10.1. Information on the testing

The mobile phone antenna and battery are those specified by the manufacturer. The battery is fully charged before each measurement. The output power and frequency are controlled using a base station simulator. The mobile phone is set to transmit at its highest output peak power level. The mobile phone is test in the “cheek” and “tilted” positions on the left and right sides of the phantom. The mobile phone is placed with the vertical centre line of the body of the mobile phone and the horizontal line crossing the centre of the earpiece in a plane parallel to the sagittal plane of the phantom.

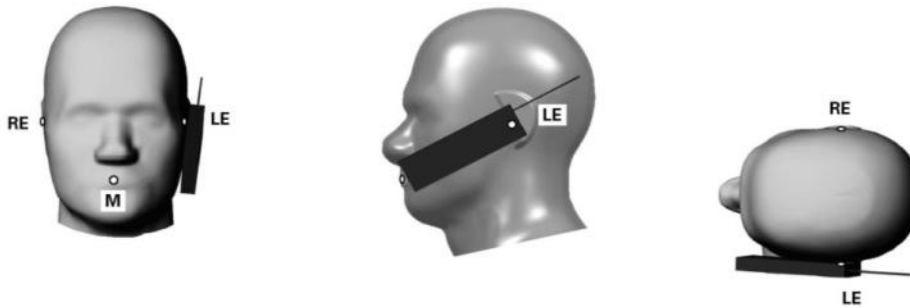

Fig 10.1 Illustration for Cheek Position

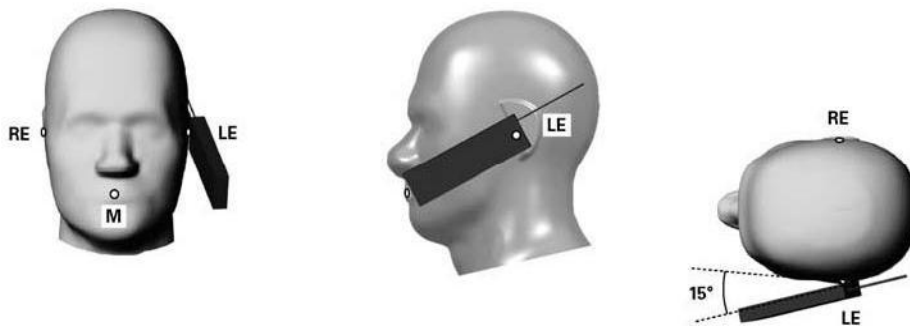

Fig 10.2 Illustration for Tilted Position

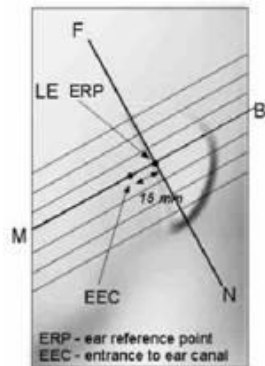

Fig 10.3 Close-up side view of phantom showing the ear region.

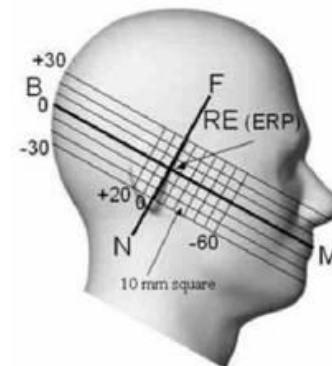

Fig 10.4 Side view of the phantom showing relevant markings and seven cross-sectional plane locations

Description of the “cheek” position:

The mobile phone is well placed in the reference plane and the earpiece is in contact with the ear. Then the mobile phone is moved until any point on the front side get in contact with the cheek of the phantom or until contact with the ear is lost.

Description of the “tilted” position:

The mobile phone is well placed in the “cheek” position as described above. Then the mobile phone is moved outward away from the mouth by an angle of 15 degrees or until contact with the ear lost.

Remark: Please refer to Appendix B for the test setup photos.

10.2. Body-worn Configurations

The body-worn configurations shall be tested with the supplied accessories (belt-clips, holsters, etc.) attached to the device in normal use configuration.

For body-worn and other configurations a flat phantom shall be used which is comprised of material with electrical properties similar to the corresponding tissues.

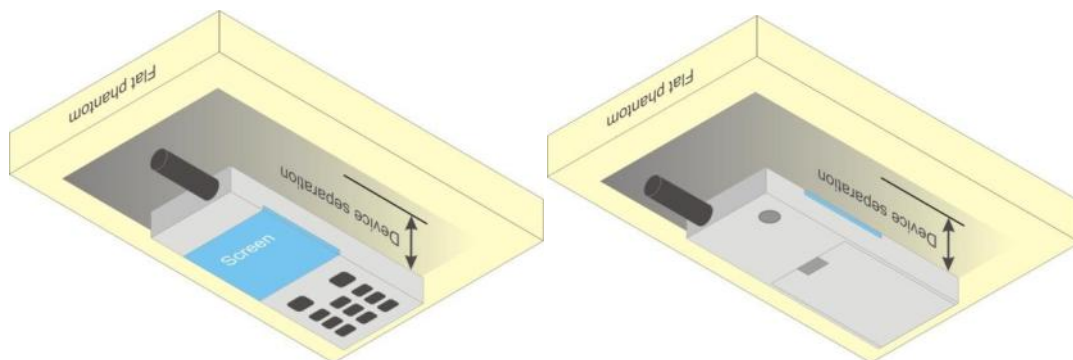

Fig 10.3 Illustration for Body Worn Position

10.3. Hotspot Mode Exposure Position Conditions

For handsets that support hotspot mode operations, with wireless router capabilities and various web browsing functions, the relevant hand and body exposure conditions are tested according to the hotspot SAR procedures in KDB 941225. A test separation distance of 10 mm is required between the phantom and all surfaces and edges with a transmitting antenna located within 25 mm from that surface or edge. When the form factor of a handset is smaller than 9 cm x 5 cm, a test separation distance of 5 mm (instead of 10 mm) is required for testing hotspot mode. When the separation distance required for body-worn accessory testing is larger than or equal to that tested for hotspot mode, in the same wireless mode and for the same surface of the phone, the hotspot mode SAR data may be used to support body-worn accessory SAR compliance for that particular configuration (surface).

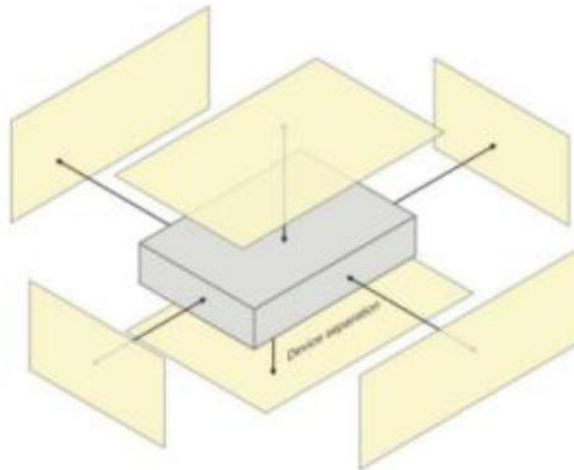

Fig 10.4 Illustration for Hotspot Position

11. SAR Measurement Procedure

11.1. General scan Requirements

Probe boundary effect error compensation is required for measurements with the probe tip closer than half a probe tip diameter to the phantom surface. Both the probe tip diameter and sensor offset distance must satisfy measurement protocols; to ensure probe boundary effect errors are minimized and the higher fields closest to the phantom surface can be correctly measured and extrapolated to the phantom surface for computing 1-g SAR. Tolerances of the post-processing algorithms must be verified by the test laboratory for the scan resolutions used in the SAR measurements, according to the reference distribution functions specified in IEEE Std 1528-2013.

| | | ≤ 3 GHz | > 3 GHz | |
|--|------------------------------------|--|---|--|
| Maximum distance from closest measurement point (geometric center of probe sensors) to phantom surface | | $5 \text{ mm} \pm 1 \text{ mm}$ | $\frac{1}{2} \cdot \delta \cdot \ln(2) \text{ mm} \pm 0.5 \text{ mm}$ | |
| Maximum probe angle from probe axis to phantom surface normal at the measurement location | | $30^\circ \pm 1^\circ$ | $20^\circ \pm 1^\circ$ | |
| Maximum area scan spatial resolution: $\Delta x_{Area}, \Delta y_{Area}$ | | ≤ 2 GHz: $\leq 15 \text{ mm}$ 2 – 3 GHz: $\leq 12 \text{ mm}$ | 3 – 4 GHz: $\leq 12 \text{ mm}$ 4 – 6 GHz: $\leq 10 \text{ mm}$ | |
| | | When the x or y dimension of the test device, in the measurement plane orientation, is smaller than the above, the measurement resolution must be \leq the corresponding x or y dimension of the test device with at least one measurement point on the test device. | | |
| Maximum zoom scan spatial resolution: $\Delta x_{Zoom}, \Delta y_{Zoom}$ | | ≤ 2 GHz: $\leq 8 \text{ mm}$ 2 – 3 GHz: $\leq 5 \text{ mm}^*$ | 3 – 4 GHz: $\leq 5 \text{ mm}^*$ 4 – 6 GHz: $\leq 4 \text{ mm}^*$ | |
| Maximum zoom scan spatial resolution, normal to phantom surface | uniform grid: $\Delta z_{Zoom}(n)$ | $\leq 5 \text{ mm}$ | 3 – 4 GHz: $\leq 4 \text{ mm}$ 4 – 5 GHz: $\leq 3 \text{ mm}$ 5 – 6 GHz: $\leq 2 \text{ mm}$ | |
| | graded grid | $\Delta z_{Zoom}(1)$: between 1 st two points closest to phantom surface | $\leq 4 \text{ mm}$ | 3 – 4 GHz: $\leq 3 \text{ mm}$ 4 – 5 GHz: $\leq 2.5 \text{ mm}$ 5 – 6 GHz: $\leq 2 \text{ mm}$ |
| | | $\Delta z_{Zoom}(n>1)$: between subsequent points | $\leq 1.5 \cdot \Delta z_{Zoom}(n-1) \text{ mm}$ | |
| Minimum zoom scan volume | x, y, z | $\geq 30 \text{ mm}$ | 3 – 4 GHz: $\geq 28 \text{ mm}$ 4 – 5 GHz: $\geq 25 \text{ mm}$ 5 – 6 GHz: $\geq 22 \text{ mm}$ | |
| Note: δ is the penetration depth of a plane-wave at normal incidence to the tissue medium; see IEEE Std 1528-2013 for details. * When zoom scan is required and the <i>reported</i> SAR from the <i>area scan based 1-g SAR estimation</i> procedures of KDB Publication 447498 is $\leq 1.4 \text{ W/kg}$, $\leq 8 \text{ mm}$, $\leq 7 \text{ mm}$ and $\leq 5 \text{ mm}$ zoom scan resolution may be applied, respectively, for 2 GHz to 3 GHz, 3 GHz to 4 GHz and 4 GHz to 6 GHz. | | | | |



11.2. Measurement procedure

The Following steps are used for each test position

1. Establish a call with the maximum output power with a base station simulator. The connection between the mobile and the base station simulator is established via air interface.
2. Measurement of the local E-field value at a fixed location. This value serves as a reference value for calculating a possible power drift.
3. Measurement of the SAR distribution with a grid of 8 to 16mm * 8 to 16 mm and a constant distance to the inner surface of the phantom. Since the sensors cannot directly measure at the inner phantom surface, the values between the sensors and the inner phantom surface are extrapolated. With these values the area of the maximum SAR is calculated by an interpolation scheme.
4. Around this point, a cube of 30 * 30 * 30 mm or 32 * 32 * 32 mm is assessed by measuring 5 or 8 * 5 or 8*4 or 5 mm. With these data, the peak spatial-average SAR value can be calculated.

11.3. Description of interpolation/extrapolation scheme

The local SAR inside the phantom is measured using small dipole sensing elements inside a probe body. The probe tip must not be in contact with the phantom surface in order to minimize measurements errors, but the highest local SAR will occur at the surface of the phantom.

An extrapolation is using to determinate this highest local SAR values. The extrapolation is based on a fourth-order least-square polynomial fit of measured data. The local SAR value is then extrapolated from the liquid surface with a 1mm step.

The measurements have to be performed over a limited time (due to the duration of the battery) so the step of measurement is high. It could vary between 5 and 8 mm. To obtain an accurate assessment of the maximum SAR averaged over 10 grams and 1 gram requires a very fine resolution in the three dimensional scanned data array.



11.4. Wireless Router

Some battery-operated handsets have the capability to transmit and receive user through simultaneous transmission of WIFI simultaneously with a separate licensed transmitter. The FCC has provided guidance in FCC KDB Publication 941225 D06 v02r01 where SAR test considerations for handsets ($L \times W \geq 9 \text{ cm} \times 5 \text{ cm}$) are based on a composite test separation distance of 10 from the front, back and edges of the device containing transmitting antennas within 2.5cm of their edges, determined from general mixed use conditions for this type of devices. Since the hotspot SAR results may overlap with the body-worn accessory SAR requirements, the more conservative configurations can be considered, thus excluding some body-worn accessory SAR tests.

When the user enables the personal wireless router functions for the handset, actual operations include simultaneous transmission of both the WIFI transmitter and another licensed transmitter. Both transmitters often do not transmit at the same transmitting frequency and thus cannot be evaluated for SAR under actual use conditions due to the limitations of the SAR assessment probes. Therefore, SAR must be evaluated for each frequency transmission and mode separately and spatially summed with the WIFI transmitter according to FCC KDB Publication 447498 D01v06 publication procedures. The "Portable Hotspot" feature on the handset was NOT activated during SAR assessments, to ensure the SAR measurements were evaluated for a single transmission frequency RF signal at a time.

12. SAR Measurement Evaluation

<GSM Mode>

A summary of these settings are illustrated below:

For GSM850 frequency band, the power control is set to 5 for GSM/GPRS mode (GSMK-CS1) and set to 8 for EDGE mode (MCS5); For GSM1900 frequency band, the power control is set to 0 for GSM/GPRS mode (GSMK-CS1) and set to 2 for EDGE mode (MCS5)

1. Per KDB 447498 D01v06, the maximum output power channel is used for SAR testing and for further SAR test reduction.
2. Per KDB 941225 D01v03r01, SAR test reduction for GSM / GPRS / EDGE modes is determined by the source-based time-averaged output power including tune-up tolerance. The mode with highest specified time-averaged output power should be tested for SAR compliance in the applicable exposure conditions. For modes with the same specified maximum output power and tolerance, the higher number time-slot configuration should be tested.
3. Other configurations of GSM / GPRS / EDGE are considered as secondary modes.

13. Measurement of Conducted output power

<GSM Mode>

| GSM850 | Burst Average Power (dBm) | | | Tune-up Limit (dBm) | Frame-Average Power (dBm) | | | Tune-up Limit (dBm) |
|-----------------|---------------------------|--------------|-------|---------------------------|---------------------------|-------|-------|---------------------------|
| | 128 | 190 | 251 | | 128 | 190 | 251 | |
| TX Channel | 824.2 | 836.6 | 848.8 | | 824.2 | 836.6 | 848.8 | |
| Frequency (MHz) | | | | | | | | |
| GSM 1 Tx slot | 32.61 | 32.69 | 32.66 | 33.00 | 23.61 | 23.69 | 23.66 | 24.00 |

| GSM1900 | Burst Average Power (dBm) | | | Tune-up Limit (dBm) | Frame-Average Power (dBm) | | | Tune-up Limit (dBm) |
|-----------------|---------------------------|--------------|--------|---------------------------|---------------------------|-------|--------|---------------------------|
| | 512 | 661 | 810 | | 512 | 661 | 810 | |
| TX Channel | 1850.2 | 1880 | 1909.8 | | 1850.2 | 1880 | 1909.8 | |
| Frequency (MHz) | | | | | | | | |
| GSM 1 Tx slot | 28.87 | 28.99 | 28.96 | 29.50 | 19.87 | 19.99 | 19.96 | 20.50 |

Timeslot consignations:

| No. of Slots | Slot 1 | Slot 2 | Slot 3 | Slot 4 |
|-------------------|----------|----------|----------|----------|
| Slot Consignation | 1Up4Down | 2Up3Down | 3Up2Down | 4Up1Down |
| Duty Cycle | 1:8.3 | 1:4.15 | 1:2.77 | 1:2.08 |
| Correct Factor | -9.03dB | -6.02dB | -4.26dB | -3.01dB |

<Bluetooth >

| Mode | Channel | Frequency (MHz) | Average power (dBm) | | |
|---------------|---------|--------------------|---------------------|-------|-------|
| | | | 1Mbps | 2Mbps | 3Mbps |
| BR / EDR | CH 00 | 2402 | 10.33 | 9.46 | 9.62 |
| | CH 39 | 2441 | 10.35 | 9.50 | 9.76 |
| | CH 78 | 2480 | 10.09 | 9.16 | 9.44 |
| Tune-up Limit | | | 10.50 | 10.00 | 10.00 |



14. Test Results List

Test Guidance:

1. Per KDB 447498 D01v06, the reported SAR is the measured SAR value adjusted for maximum tune-up tolerance.
 - a. Tune-up scaling Factor = tune-up limit power (mW) / EUT RF power (mW), where tune-up limit is the maximum rated power among all production units.
 - b. For SAR testing of WLAN signal with non-100% duty cycle, the measured SAR is scaled-up by the duty cycle scaling factor which is equal to "1/(duty cycle)"
 - c. For WWAN: Reported SAR(W/kg)= Measured SAR(W/kg)*Tune-up Scaling Factor
2. Per KDB 447498 D01v06, for each exposure position, testing of other required channels within the operating mode of a frequency band is not required when the reported 1-g or 10-g SAR for the mid-band or highest output power channel is:
 - ≤ 0.8 W/kg or 2.0 W/kg, for 1-g or 10-g respectively, when the transmission band is ≤ 100 MHz
 - ≤ 0.6 W/kg or 1.5 W/kg, for 1-g or 10-g respectively, when the transmission band is between 100 MHz and 200 MHz
 - ≤ 0.4 W/kg or 1.0 W/kg, for 1-g or 10-g respectively, when the transmission band is ≥ 200 MHz
3. Per KDB 865664 D01v01r04, for each frequency band, repeated SAR measurement is required only when the measured SAR is ≥0.8W/kg.
4. Per KDB 648474 D04v01r03, when the reported SAR for a body-worn accessory measured without a headset connected to the handset is ≤ 1.2 W/kg, SAR testing with a headset connected to the handset is not required.

<GSM>

1. Per KDB 447498 D01v06, the maximum output power channel is used for SAR testing and for further SAR test reduction.
2. Per KDB 941225 D01v03r01, for SAR test reduction for GSM / GPRS / EDGE modes is determined by the source-based time-averaged output power including tune-up tolerance. The mode with highest specified time-averaged output power should be tested for SAR compliance in the applicable exposure conditions. For modes with the same specified maximum output power and tolerance, the higher number time-slot configuration should be tested. Therefore, the GPRS (4Tx slots) for GSM850/GSM1900 is considered as the primary mode.
3. Other configurations of GSM / GPRS / EDGE are considered as secondary modes.



<Bluetooth>

1. According to KDB 447498 section 4.3.1, the 1-g SAR test exclusion thresholds at test separation distances ≤ 50 mm are determined by following:

| Test distance: 10mm | | | |
|----------------------------|--------------------------------------|--|-----------------------|
| Band | Highest power(mW) per tune up | 1-g SAR test threshold | Test required? |
| Bluetooth | 11.00 | $[(\text{max. power of channel, including tune-up tolerance, mW}) / (\text{min. test separation distance, mm})] \cdot [\sqrt{f(\text{GHz})}] \leq 3.0$ for 1-g SAR | No |

2. The BT Body stand-alone SAR is not required, the standalone SAR must be estimated according to following to determine simultaneous transmission SAR test exclusion:
 (Max power=11.00mW; min. test separation distance= 10mm for Body; f=2.4GHz)
 Bluetooth estimated Body SAR =0.229W/Kg (1g)



15.1. Head SAR Evaluation

<GSM 850/GSM1900>

| Plot No. | Band | Mode | Test Position | Ch. | Average Power (dBm) | Tune-Up Limit (dBm) | Tune-up Scaling Factor | Measured 1g SAR (W/kg) | Reported 1g SAR (W/kg) |
|----------|---------|-----------|---------------|-----|---------------------|---------------------|------------------------|------------------------|------------------------|
| | GSM850 | GSM Voice | Right Cheek | 190 | 32.69 | 33.00 | 1.074 | 0.788 | 0.846 |
| | GSM850 | GSM Voice | Right Tilt | 190 | 32.69 | 33.00 | 1.074 | 0.331 | 0.355 |
| | GSM850 | GSM Voice | Left Cheek | 190 | 32.69 | 33.00 | 1.074 | 0.860 | 0.924 |
| | GSM850 | GSM Voice | Left Tilt | 190 | 32.69 | 33.00 | 1.074 | 0.274 | 0.294 |
| | GSM850 | GSM Voice | Left Cheek | 128 | 32.61 | 33.00 | 1.094 | 0.666 | 0.729 |
| 1# | GSM850 | GSM Voice | Left Cheek | 251 | 32.66 | 33.00 | 1.081 | 0.863 | 0.933 |
| | | | | | | | | | |
| 2# | GSM1900 | GSM Voice | Right Cheek | 661 | 28.99 | 29.50 | 1.125 | 0.330 | 0.371 |
| | GSM1900 | GSM Voice | Right Tilt | 661 | 28.99 | 29.50 | 1.125 | 0.179 | 0.201 |
| | GSM1900 | GSM Voice | Left Cheek | 661 | 28.99 | 29.50 | 1.125 | 0.316 | 0.355 |
| | GSM1900 | GSM Voice | Left Tilt | 661 | 28.99 | 29.50 | 1.125 | 0.171 | 0.192 |

15.2. Body-worn SAR Evaluation (Test distance 10mm)

<GSM 850/GSM1900>

| | Band | Mode | Test Position | Ch. | Average Power (dBm) | Tune-Up Limit (dBm) | Tune-up Scaling Factor | Measured 1g SAR (W/kg) | Reported 1g SAR (W/kg) |
|----|---------|-----------|---------------|-----|---------------------|---------------------|------------------------|------------------------|------------------------|
| | GSM850 | GSM Voice | Front Side | 190 | 32.69 | 33.00 | 1.074 | 0.603 | 0.648 |
| | GSM850 | GSM Voice | Back Side | 190 | 32.69 | 33.00 | 1.074 | 0.904 | 0.971 |
| 3# | GSM850 | GSM Voice | Back Side | 128 | 32.61 | 33.00 | 1.094 | 0.890 | 0.974 |
| | GSM850 | GSM Voice | Back Side | 251 | 32.66 | 33.00 | 1.081 | 0.883 | 0.955 |
| | | | | | | | | | |
| | GSM1900 | GSM Voice | Front Side | 661 | 28.99 | 29.50 | 1.125 | 0.152 | 0.171 |
| 3# | GSM1900 | GSM Voice | Back Side | 661 | 28.99 | 29.50 | 1.125 | 0.347 | 0.390 |

15. Simultaneous Transmission Evaluation

Simultaneous Evaluation:

| No. | Simultaneous transmission Condition | Head | Body-worn |
|-----|-------------------------------------|------|-----------|
| 1 | GSM/GPRS/EDGE + Bluetooth | Yes | Yes |

Note:

1. When the user enables the personal wireless router functions for the handset, actual operations include simultaneous transmission of both the BT transmitter and another WWAN transmitter. Both transmitter often do not transmit at the same transmitting frequency and thus cannot be evaluated for SAR under actual use conditions. The "Portable Hotspot" feature on the handset was NOT activated, to ensure the SAR measurements were evaluated for a single transmission frequency RF signal.
2. The hotspot SAR result may overlap with the body-worn accessory SAR requirements, per KDB 941225 D06, the more conservative configurations can be considered, thus excluding some unnecessary body-worn accessory SAR tests.
3. GSM supports voice and data transmission, though not simultaneously.
4. Simultaneous Transmission SAR evaluation is not required for BT, because the software mechanism have been incorporated to guarantee that the WLAN and Bluetooth transmitters would not simultaneously operate.
5. Per KDB 447498D01v06, Simultaneous Transmission SAR Evaluation procedures is as followed:
 - Step 1: If sum of 1 g SAR < 1.6 W/kg, Simultaneous SAR measurement is not required.
 - Step 2: If sum of 1 g SAR > 1.6 W/kg, ratio of SAR to peak separation distance for pair of transmitters calculated.
 - Step 3: If the ratio of SAR to peak separation distance is ≤ 0.04 , Simultaneous SAR measurement is not required.
 - Step 4: If the ratio of SAR to peak separation distance is > 0.04, Simultaneous SAR measurement is required and simultaneous transmission SAR value is calculated.
(The ratio is determined by: $(SAR1 + SAR2) \wedge 1.5/Ri \leq 0.04$,
Ri is the separation distance between the peak SAR locations for the antenna pair in mm.
6. For simultaneous transmission analysis, Bluetooth SAR is estimated per KDB 447498 D01v06 based on the formula below.
 - i) (max. power of channel, including tune-up tolerance, mW)/(min. test separation distance, mm)] $\cdot \sqrt{f(\text{GHz})/x}$ W/kg for test separation distances ≤ 50 mm; where x = 7.5 for 1-g SAR, and x = 18.75 for 10-g SAR.
 - ii) When the minimum separation distance is < 5mm, the distance is used 5mm to determine SAR test exclusion.



iii) 0.4 W/kg for 1-g SAR and 1.0 W/kg for 10-g SAR, when the test separation distances is > 50 mm.

<Bluetooth Estimated SAR>

| Maximum tune-up tolerance (dBm) | Maximum tune-up tolerance (mW) | Minimum Distance(mm) | Frequency(GHz) | Test threshold |
|---------------------------------|--------------------------------|----------------------|----------------|----------------|
| 10.50 | 11.00 | 10 | 2.441 | 1.72 |

| Maximum tune-up tolerance (dBm) | Maximum tune-up tolerance (mW) | Minimum Distance(mm) | Frequency(GHz) | Estimated SAR (W/kg) |
|---------------------------------|--------------------------------|----------------------|----------------|----------------------|
| 10.50 | 11.00 | 10 | 2.441 | 0.229 |

Note: Held-to ear configuration are not applicable to Bluetooth operations and therefore were not considered for simultaneous transmission.

<Body-worn Exposure>

| WWAN Band | | Exposure Position | WWAN | Bluetooth | WWAN+ Bluetooth Summed 1g SAR (W/kg) |
|-----------|---------|-------------------|---------------|-------------------------|--------------------------------------|
| | | | 1g SAR (W/kg) | Estimated 1g SAR (W/kg) | |
| GSM | GSM850 | Front | 0.648 | 0.229 | 0.877 |
| | | Back | 0.974 | 0.229 | 1.203 |
| | GSM1900 | Front | 0.171 | 0.229 | 0.400 |
| | | Back | 0.390 | 0.229 | 0.619 |