



FCC TEST REPORT (PART 24)

REPORT NO.: RF120131C05-5

MODEL NO.: T-02D

FCC ID: VQK-T02D

RECEIVED: Jan. 31, 2012

TESTED: Mar. 02 ~ Apr. 23, 2012

ISSUED: Apr. 25, 2012

APPLICANT: FUJITSU LIMITED

ADDRESS: 1-1, Kamikodanaka 4-chome, Nakahara-ku,
Kawasaki 211-8588, Japan

ISSUED BY: Bureau Veritas Consumer Products Services
(H.K.) Ltd., Taoyuan Branch

LAB ADDRESS: No. 47, 14th Ling, Chia Pau Vil., Lin Kou Dist., New
Taipei City, Taiwan (R.O.C.)

TEST LOCATION: No. 19, Hwa Ya 2nd Rd, Wen Hwa Tsuen, Kwei
Shan Hsiang, Taoyuan Hsien 333, Taiwan, R.O.C.

This test report consists of 37 pages in total. It may be duplicated completely for legal use with the approval of the applicant. It should not be reproduced except in full, without the written approval of our laboratory. The client should not use it to claim product endorsement by TAF or any government agencies. The test results in the report only apply to the tested sample.





A D T

TABLE OF CONTENTS

RELEASE CONTROL RECORD	3
1 CERTIFICATION	4
2 SUMMARY OF TEST RESULTS	5
2.1 MEASUREMENT UNCERTAINTY	5
2.2 TEST SITE AND INSTRUMENTS	6
3 GENERAL INFORMATION	7
3.1 GENERAL DESCRIPTION OF EUT	7
3.2 CONFIGURATION OF SYSTEM UNDER TEST	8
3.3 DESCRIPTION OF SUPPORT UNITS	8
3.4 TEST ITEM AND TEST CONFIGURATION	9
3.5 EUT OPERATING CONDITIONS	10
3.6 GENERAL DESCRIPTION OF APPLIED STANDARDS	10
4 TEST TYPES AND RESULTS	11
4.1 OUTPUT POWER MEASUREMENT	11
4.1.1 LIMITS OF OUTPUT POWER MEASUREMENT	11
4.1.2 TEST PROCEDURES	11
4.1.3 TEST SETUP	12
4.1.4 TEST RESULTS	13
4.2 FREQUENCY STABILITY MEASUREMENT	16
4.2.1 LIMITS OF FREQUENCY STABILITY MEASUREMENT	16
4.2.2 TEST PROCEDURE	16
4.2.3 TEST SETUP	16
4.2.4 TEST RESULTS	17
4.3 OCCUPIED BANDWIDTH MEASUREMENT	18
4.3.1 TEST PROCEDURES	18
4.3.2 TEST SETUP	18
4.3.3 TEST RESULTS	19
4.4 BAND EDGE MEASUREMENT	20
4.4.1 LIMITS OF BAND EDGE MEASUREMENT	20
4.4.2 TEST SETUP	20
4.4.3 TEST PROCEDURES	20
4.4.4 TEST RESULTS	21
4.5 CONDUCTED SPURIOUS EMISSIONS	22
4.5.1 LIMITS OF CONDUCTED SPURIOUS EMISSIONS MEASUREMENT	22
4.5.2 TEST PROCEDURE	22
4.5.3 TEST SETUP	22
4.5.4 TEST RESULTS	23
4.6 RADIATED EMISSION MEASUREMENT	29
4.6.1 LIMITS OF RADIATED EMISSION MEASUREMENT	29
4.6.2 TEST PROCEDURES	29
4.6.3 DEVIATION FROM TEST STANDARD	29
4.6.4 TEST SETUP	30
4.6.5 TEST RESULTS	31
5 PHOTOGRAPHS OF THE TEST CONFIGURATION	35
6 INFORMATION ON THE TESTING LABORATORIES	36
7 APPENDIX A – MODIFICATIONS RECORDERS FOR ENGINEERING CHANGES TO THE EUT BY THE LAB	37



A D T

RELEASE CONTROL RECORD

ISSUE NO.	REASON FOR CHANGE	DATE ISSUED
RF120131C05-5	Original release	Apr. 25, 2012



1 CERTIFICATION

PRODUCT: Mobile Phone
MODEL: T-02D
BRAND: Xi
APPLICANT: FUJITSU LIMITED
TESTED: Mar. 02 ~ Apr. 23, 2012
TEST SAMPLE: ENGINEERING SAMPLE
STANDARDS: **FCC Part 24, Subpart E**

The above equipment (model: T-02D) has been tested by **Bureau Veritas Consumer Products Services (H.K.) Ltd., Taoyuan Branch**, and found compliance with the requirement of the above standards. The test record, data evaluation & Equipment Under Test (EUT) configurations represented herein are true and accurate accounts of the measurements of the sample's EMC characteristics under the conditions specified in this report.

PREPARED BY : Andrea Hsia , DATE : Apr. 25, 2012
Andrea Hsia / Specialist

APPROVED BY : Gary Chang , DATE : Apr. 25, 2012
Gary Chang / Technical Manager

2 SUMMARY OF TEST RESULTS

The EUT has been tested according to the following specifications:

APPLIED STANDARD: FCC Part 24 & Part 2			
STANDARD SECTION	TEST TYPE	RESULT	REMARK
2.1046 24.232	Equivalent isotropically radiated power	PASS	Meet the requirement of limit.
2.1055 24.235	Frequency Stability	PASS	Meet the requirement of limit.
2.1049 24.238(b)	Occupied Bandwidth	PASS	Meet the requirement of limit.
24.238(b)	Band Edge Measurements	PASS	Meet the requirement of limit.
2.1051 24.238	Conducted Spurious Emissions	PASS	Meet the requirement of limit.
2.1053 24.238	Radiated Spurious Emissions	PASS	Meet the requirement of limit. Minimum passing margin is -17.4dB at 3760.0MHz.

2.1 MEASUREMENT UNCERTAINTY

Where relevant, the following measurement uncertainty levels have been estimated for tests performed on the EUT as specified in CISPR 16-4-2:

MEASUREMENT	FREQUENCY	UNCERTAINTY
Conducted emissions	9kHz~30MHz	2.44 dB
Radiated emissions	30MHz ~ 200MHz	3.34 dB
	200MHz ~1000MHz	3.35 dB
	1GHz ~ 18GHz	2.26 dB
	18GHz ~ 40GHz	1.94 dB

This uncertainty represents an expanded uncertainty expressed at approximately the 95% confidence level using a coverage factor of k=2.



2.2 TEST SITE AND INSTRUMENTS

DESCRIPTION & MANUFACTURER	MODEL NO.	SERIAL NO.	DATE OF CALIBRATION	DUE DATE OF CALIBRATION
Test Receiver ROHDE & SCHWARZ	ESIB7	100212	Aug. 02, 2011	Aug. 01, 2012
Spectrum Analyzer ROHDE & SCHWARZ	FSP40	100041	Jul. 21, 2011	Jul. 20, 2012
BILOG Antenna SCHWARZBECK	VULB9168	9168-472	Dec. 20, 2011	Dec. 19, 2012
HORN Antenna SCHWARZBECK	9120D	209	Aug. 25, 2011	Aug. 24, 2012
HORN Antenna SCHWARZBECK	BBHA 9170	148	Jul. 20, 2011	Jul. 19, 2012
Preamplifier Agilent	8447D	2944A10633	Oct. 29, 2011	Oct. 28, 2012
Preamplifier Agilent	8449B	3008A01964	Oct. 29, 2011	Oct. 28, 2012
RF signal cable HUBER+SUHNNER	SUCOFLEX 104	250723/4	Aug. 30, 2011	Aug. 29, 2012
RF signal cable HUBER+SUHNNER	SUCOFLEX 106	12738/6+309224/4	Aug. 30, 2011	Aug. 29, 2012
Software ADT.	ADT_Radiated_ V7.6.15.9.2	NA	NA	NA
Antenna Tower inn-co GmbH	MA 4000	013303	NA	NA
Antenna Tower Controller inn-co GmbH	CO2000	017303	NA	NA
Turn Table ADT.	TT100	TT93021703	NA	NA
Turn Table Controller ADT.	SC100	SC93021703	NA	NA
Communication Tester R&S	CMU200	104484	Dec. 30, 2011	Dec. 29, 2012
Standard Temperature & Humidity Chamber WIT	MHU-225AU	920842	Jun. 15, 2011	Jun. 14, 2012
Mini-Circuits Power Splitter	ZN2PD-9G	NA	May 25, 2011	May 24, 2012
JFW 20dB attenuation	50HF-020-SMA	NA	NA	NA

NOTE: 1. The calibration interval of the above test instruments is 12 months and the calibrations are traceable to NML/ROC and NIST/USA.

2. The test was performed in HwaYa Chamber 3.

3. The horn antenna and HP preamplifier (model: 8449B) are used only for the measurement of emission frequency above 1GHz if tested.

4. The FCC Site Registration No. is 988962.

5. The IC Site Registration No. is IC 7450F-3.



3 GENERAL INFORMATION

3.1 GENERAL DESCRIPTION OF EUT

EUT	Mobile Phone
MODEL NO.	T-02D
POWER SUPPLY	3.7Vdc (Li-ion battery) 5.0Vdc (Adapter)
MODULATION TYPE	GMSK
FREQUENCY RANGE	1850.2MHz ~ 1909.8MHz
MAX. ERP POWER	GSM: 27.3dBm (0.5370Watts) GPRS: 26.9dBm (0.4898Watts)
MULTI-SLOTS CLASS	12
ANTENNA TYPE	$\lambda/4$ Monopole antenna with -1.1dBi gain
DATA CABLE	NA
I/O PORTS	Refer to user's manual
ACCESSORY DEVICES	Adapter, Battery

NOTE:

1. The EUT consumes power from the following adapter & internal Li-ion battery.

ADAPTER	
BRAND:	NTT docomo
MODEL:	TA08017-B219
INPUT:	100-240Vac, 50/60Hz, 0.22A
OUTPUT:	5Vdc, 1.8A

BATTERY	
BRAND	Fujitsu Limited
MODEL	F25
RATING	3.7Vdc, 1800mAh, 6.7Wh

2. The following accessory is for support units only.

PRODUCT	BRAND	DESCRIPTION
USB cable	NA	1.1m non-shielded cable without core

3. SW version is R07.1.
4. HW version is V2.1.0.
5. IMEI Code: 351537050016811.
6. The above EUT information was declared by manufacturer and for more detailed features description, please refer to the manufacturer's specifications or User's Manual.

3.2 CONFIGURATION OF SYSTEM UNDER TEST

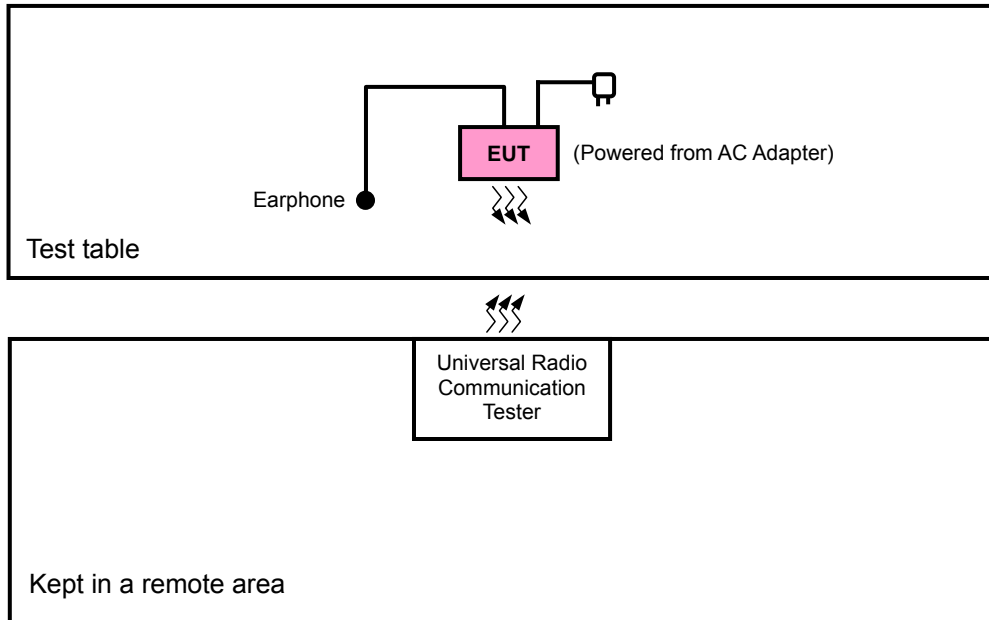

3.3 DESCRIPTION OF SUPPORT UNITS

The EUT has been tested as an independent unit together with other necessary accessories or support units. The following support units or accessories were used to form a representative test configuration during the tests.

NO.	PRODUCT	BRAND	MODEL NO.	SERIAL NO.	FCC ID
1	EARPHONE	Apple	NA	NA	NA

NO.	SIGNAL CABLE DESCRIPTION OF THE ABOVE SUPPORT UNITS
1	1.15m non-shielded cable

NOTE: All power cords of the above support units are non shielded (1.8m).



3.4 TEST ITEM AND TEST CONFIGURATION

Pre-Scan has been conducted to determine the worst-case mode from all possible combinations between available modulations, data rates, XYZ axis and antenna ports

The worst case was found when positioned on X-plane. Following channel(s) was (were) selected for the final test as listed below:

GSM MODE

TEST ITEM	AVAILABLE CHANNEL	TESTED CHANNEL	MODE
EIRP	512 to 810	512, 661, 810	GSM, GPRS
FREQUENCY STABILITY	512 to 810	661	GSM
OCCUPIED BANDWIDTH	512 to 810	512, 661, 810	GSM, GPRS
BAND EDGE	512 to 810	512, 810	GSM, GPRS
CONDCUDED EMISSION	512 to 810	512, 661, 810	GSM, GPRS
RADIATED EMISSION BELOW 1 GHz	512 to 810	512	GSM
RADIATED EMISSION ABOCE 1 GHz	512 to 810	512, 661, 810	GSM

TEST CONDITION:

TEST ITEM	ENVIRONMENTAL CONDITIONS	INPUT POWER	TESTED BY
ERP	25deg. C, 65%RH	3.7Vdc	Aska Huang
FREQUENCY STABILITY	26deg. C, 65%RH	3.7Vdc	Brad Wu
OCCUPIED BANDWIDTH	26deg. C, 65%RH	3.7Vdc	Brad Wu
BAND EDGE	26deg. C, 65%RH	3.7Vdc	Brad Wu
CONDCUDED EMISSION	26deg. C, 65%RH	3.7Vdc	Brad Wu
RADIATED EMISSION	25deg. C, 65%RH	3.7Vdc	Aska Huang

3.5 EUT OPERATING CONDITIONS

The EUT makes a call to the communication simulator. The communication simulator station system controlled a EUT to export maximum output power under transmission mode and specific channel frequency

3.6 GENERAL DESCRIPTION OF APPLIED STANDARDS

The EUT is a RF product. According to the specifications of the manufacturer, it must comply with the requirements of the following standards:

FCC 47 CFR Part 2

FCC 47 CFR Part 24

ANSI/TIA/EIA-603-C 2004

NOTE: All test items have been performed and recorded as per the above standards.

4 TEST TYPES AND RESULTS

4.1 OUTPUT POWER MEASUREMENT

4.1.1 LIMITS OF OUTPUT POWER MEASUREMENT

Mobile and portable stations are limited to 2 watts EIRP

4.1.2 TEST PROCEDURES

EIRP MEASUREMENT:

- a. All measurements were done at low, middle and high operational frequency range. RWB and VBW is 1MHz.
- b. Substitution method is used for E.I.R.P measurement. In the semi-anechoic chamber, EUT placed on the 0.8m height of Turn Table, rotated the table around 360 degrees to search the maximum radiation power and receiver antenna shall be rotated vertical and horizontal polarization and moved height from 1m to 4m to find the maximum polar radiated power. The “Read Value” is the spectrum reading the maximum power value.
- c. The substitution horn antenna is substituted for EUT at the same position and signals generator export the CW signal to the substitution antenna via a tx cable. Rotated the Turn Table and moved receiving antenna to find the maximum radiation power. Adjust output power level of S.G to get a Value of spectrum reading equal to “Read Value “ of step b. Record the power level of S.G
- d. $EIRP = \text{Output power level of S.G} - \text{TX cable loss} + \text{Antenna gain of substitution horn.}$

CONDUCTED POWER MEASUREMENT:

The EUT was set up for the maximum power with GSM, GPRS link data modulation and link up with simulator. Set the EUT to transmit under low, middle and high channel and record the power level shown on simulator.

4.1.3 TEST SETUP

EIRP MEASUREMENT:

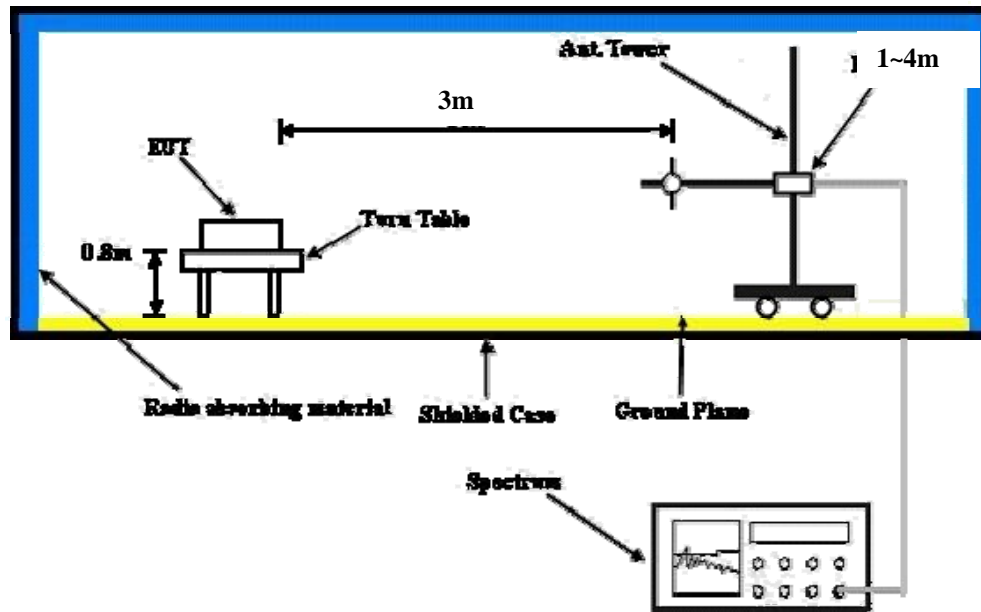

For the actual test configuration, please refer to the attached file (Test Setup Photo).

CONDUCTED POWER MEASUREMENT:

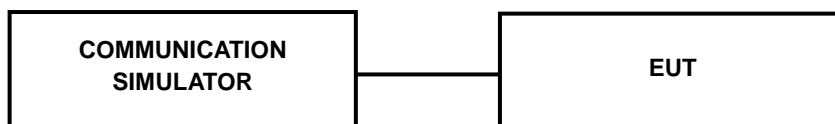

For the actual test configuration, please refer to the attached file (Test Setup Photo).



A D T

4.1.4 TEST RESULTS

CONDUCTED OUTPUT POWER (dBm)

Band	GSM1900		
Channel	512	661	810
Frequency (MHz)	1850.2	1880.0	1909.8
GSM	30.58	30.80	30.79
GPRS 8	30.22	30.46	30.55
GPRS 10	27.83	28.07	28.02
GPRS 11	26.18	26.28	26.34
GPRS 12	24.95	24.93	25.16
DTM 11 (GPRS)	26.33	26.54	26.57



A D T

EIRP POWER (dBm)

FOR GSM MODE:

MODE		TX channel 512					
ANTENNA POLARITY & TEST DISTANCE: HORIZONTAL AT 3 M							
No.	Freq. (MHz)	Reading (dBm)	S.G Power Value (dBm)	Correction Factor (dB)	EIRP (dBm)	Limit (dBm)	Margin (dB)
1	1850.2	-9.9	26.2	1.1	27.3	33.0	-5.7
ANTENNA POLARITY & TEST DISTANCE: VERTICAL AT 3 M							
No.	Freq. (MHz)	Reading (dBm)	S.G Power Value (dBm)	Correction Factor (dB)	EIRP (dBm)	Limit (dBm)	Margin (dB)
1	1850.2	-14.0	20.9	1.1	22.0	33.0	-11.0

NOTE: Power Value (dBm) = S.G Power Value (dBm) + Correction Factor (dB).

MODE		TX channel 661					
ANTENNA POLARITY & TEST DISTANCE: HORIZONTAL AT 3 M							
No.	Freq. (MHz)	Reading (dBm)	S.G Power Value (dBm)	Correction Factor (dB)	EIRP (dBm)	Limit (dBm)	Margin (dB)
1	1880.0	-9.5	26.0	1.1	27.1	33.0	-5.9
ANTENNA POLARITY & TEST DISTANCE: VERTICAL AT 3 M							
No.	Freq. (MHz)	Reading (dBm)	S.G Power Value (dBm)	Correction Factor (dB)	EIRP (dBm)	Limit (dBm)	Margin (dB)
1	1880.0	-13.3	21.1	1.1	22.2	33.0	10.8

NOTE: Power Value (dBm) = S.G Power Value (dBm) + Correction Factor (dB).

MODE		TX channel 810					
ANTENNA POLARITY & TEST DISTANCE: HORIZONTAL AT 3 M							
No.	Freq. (MHz)	Reading (dBm)	S.G Power Value (dBm)	Correction Factor (dB)	EIRP (dBm)	Limit (dBm)	Margin (dB)
1	1909.8	-9.8	25.6	1.1	26.7	33.0	-6.3
ANTENNA POLARITY & TEST DISTANCE: VERTICAL AT 3 M							
No.	Freq. (MHz)	Reading (dBm)	S.G Power Value (dBm)	Correction Factor (dB)	EIRP (dBm)	Limit (dBm)	Margin (dB)
1	1909.8	-15.7	19.7	1.1	20.8	33.0	-12.2

NOTE: Power Value (dBm) = S.G Power Value (dBm) + Correction Factor (dB).



A D T

FOR GPRS MODE:

MODE		TX channel 512					
ANTENNA POLARITY & TEST DISTANCE: HORIZONTAL AT 3 M							
No.	Freq. (MHz)	Reading (dBm)	S.G Power Value (dBm)	Correction Factor (dB)	EIRP (dBm)	Limit (dBm)	Margin (dB)
1	1850.2	-10.3	25.8	1.1	26.9	33.0	-6.1
ANTENNA POLARITY & TEST DISTANCE: VERTICAL AT 3 M							
No.	Freq. (MHz)	Reading (dBm)	S.G Power Value (dBm)	Correction Factor (dB)	EIRP (dBm)	Limit (dBm)	Margin (dB)
1	1850.2	-13.84	21.13	1.07	22.20	33.0	-10.8

NOTE: Power Value (dBm) = S.G Power Value (dBm) + Correction Factor (dB).

MODE		TX channel 661					
ANTENNA POLARITY & TEST DISTANCE: HORIZONTAL AT 3 M							
No.	Freq. (MHz)	Reading (dBm)	S.G Power Value (dBm)	Correction Factor (dB)	EIRP (dBm)	Limit (dBm)	Margin (dB)
1	1880.0	-9.7	25.8	1.1	26.9	33.0	-6.1
ANTENNA POLARITY & TEST DISTANCE: VERTICAL AT 3 M							
No.	Freq. (MHz)	Reading (dBm)	S.G Power Value (dBm)	Correction Factor (dB)	EIRP (dBm)	Limit (dBm)	Margin (dB)
1	1880.0	-13.5	20.9	1.1	22.0	33.0	-11.0

NOTE: Power Value (dBm) = S.G Power Value (dBm) + Correction Factor (dB).

MODE		TX channel 810					
ANTENNA POLARITY & TEST DISTANCE: HORIZONTAL AT 3 M							
No.	Freq. (MHz)	Reading (dBm)	S.G Power Value (dBm)	Correction Factor (dB)	EIRP (dBm)	Limit (dBm)	Margin (dB)
1	1909.8	-10.5	24.9	1.1	26.0	33.0	-7.0
ANTENNA POLARITY & TEST DISTANCE: VERTICAL AT 3 M							
No.	Freq. (MHz)	Reading (dBm)	S.G Power Value (dBm)	Correction Factor (dB)	EIRP (dBm)	Limit (dBm)	Margin (dB)
1	1909.8	-16.1	19.3	1.1	20.4	33.0	-12.6

NOTE: Power Value (dBm) = S.G Power Value (dBm) + Correction Factor (dB).

4.2 FREQUENCY STABILITY MEASUREMENT

4.2.1 LIMITS OF FREQUENCY STABILITY MEASUREMENT

The frequency stability shall be sufficient to ensure that the fundamental emission stays within the authorized frequency block.

4.2.2 TEST PROCEDURE

- a. Device is placed at the oven room. The oven room could control the temperatures and humidity. Power warm up is at least 15 min and power applied should perform before recording frequency error.
- b. EUT is connected the external power supply to control the DC input power. The test voltage range is from minimum to maximum working voltage. Each step shall be record the frequency error rate.
- c. The temperature range step is 10 degrees in this test items. All temperature levels shall be hold the $\pm 0.5^{\circ}\text{C}$ during the measurement testing. The each temperature step shall be at least 0.5 hours, consider the EUT could be test under the stability condition.

NOTE: The frequency error was recorded frequency error from the communication simulator.

4.2.3 TEST SETUP

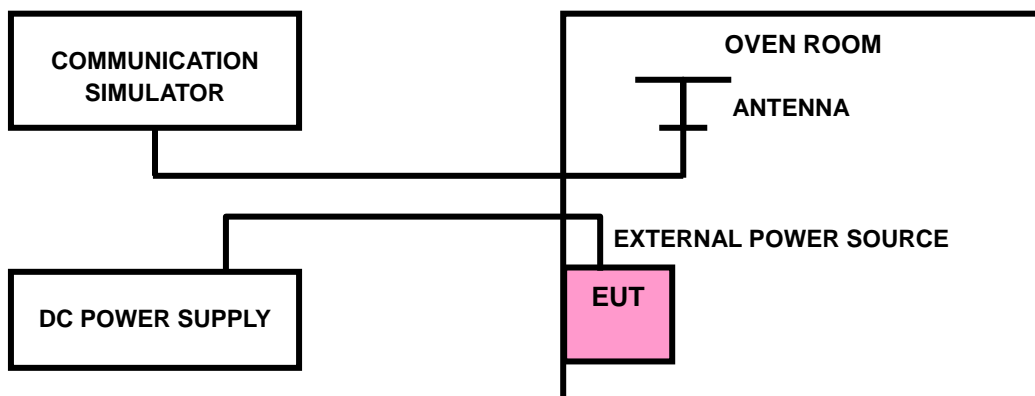

4.2.4 TEST RESULTS

FREQUENCY ERROR vs. VOLTAGE

VOLTAGE (Volts)	FREQUENCY ERROR (ppm)	LIMIT (ppm)
4.07	-0.014	2.5
3.33	-0.011	2.5

NOTE: The applicant defined the normal working voltage of the battery is from 3.33Vdc to 4.07Vdc.

FREQUENCY ERROR vs. TEMPERATURE

TEMP. (°C)	FREQUENCY ERROR (ppm)	LIMIT (ppm)
55	-0.013	2.5
50	-0.010	2.5
40	-0.010	2.5
30	-0.009	2.5
20	-0.007	2.5
10	-0.006	2.5
0	-0.008	2.5
-10	-0.009	2.5
-20	-0.011	2.5
-30	-0.012	2.5

4.3 OCCUPIED BANDWIDTH MEASUREMENT

4.3.1 TEST PROCEDURES

The EUT makes a call to the communication simulator. All measurements were done at low, middle and high operational frequency range. The communication simulator station system controlled a EUT to export maximum output power under transmission mode and specific channel frequency. Use OBW measurement function of Spectrum analyzer to measure 99 % occupied bandwidth.

4.3.2 TEST SETUP

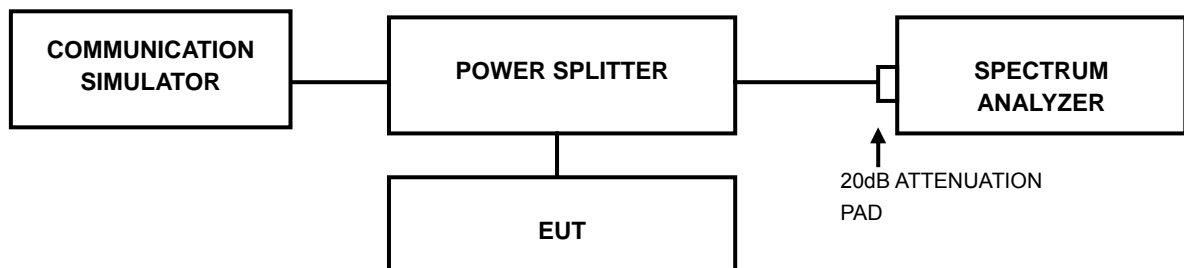



A D T

4.3.3 TEST RESULTS

CHANNEL	FREQUENCY (MHz)	99% OCCUPIED BANDWIDTH (kHz)	
		GSM	GPRS
512	1850.2	244	246
661	1880.0	246	242
810	1909.8	244	248

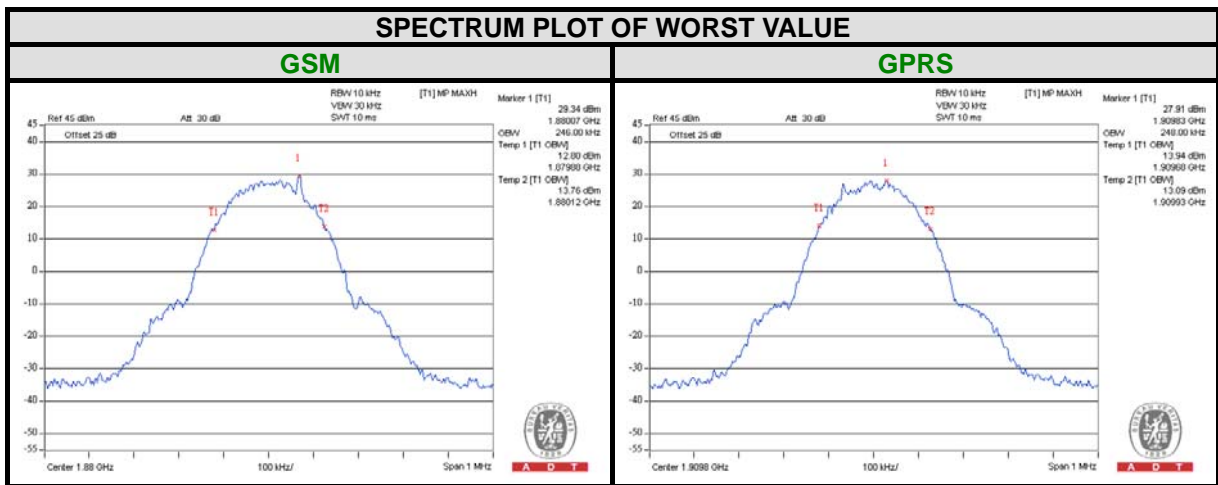

4.4 BAND EDGE MEASUREMENT

4.4.1 LIMITS OF BAND EDGE MEASUREMENT

Power of any emission outside of the authorized operating frequency ranges must be attenuated below the transmitting power (P) by a factor of at least $43 + 10 \log(P)$ dB. In the 1 MHz bands immediately outside and adjacent to the frequency block a resolution bandwidth of at least one percent of the emission bandwidth of the fundamental emission of the transmitter may be employed.

4.4.2 TEST SETUP

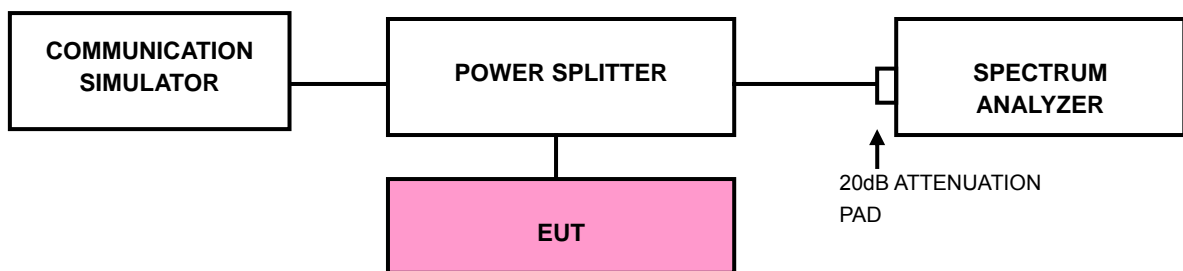

4.4.3 TEST PROCEDURES

- All measurements were done at low and high operational frequency range.
- The center frequency of spectrum is the band edge frequency and span is 1.5 MHz. RB of the spectrum is 3kHz and VB of the spectrum is 10kHz.
- Record the max trace plot into the test report.

4.4.4 TEST RESULTS

FOR GSM MODE:

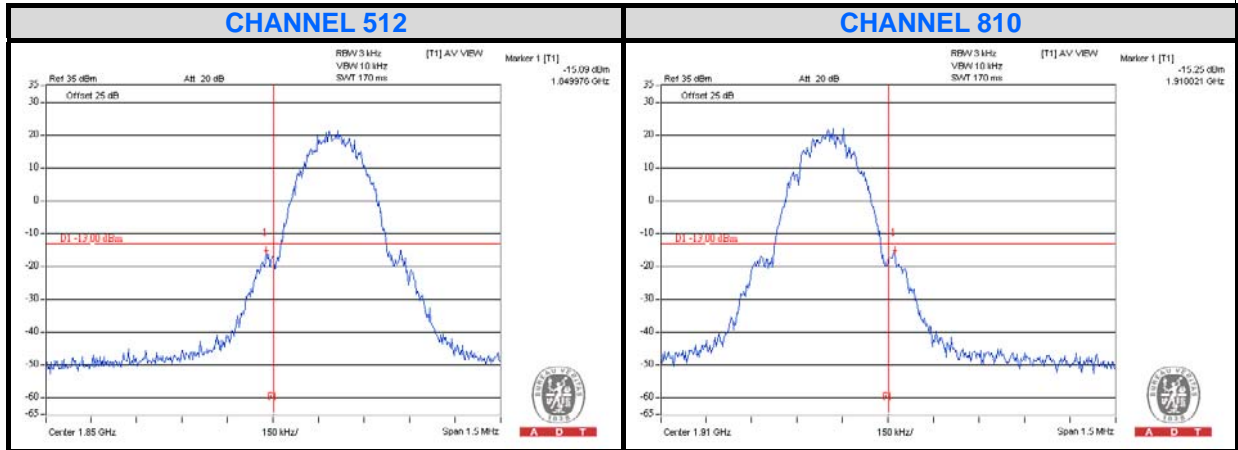

FOR GPRS MODE:

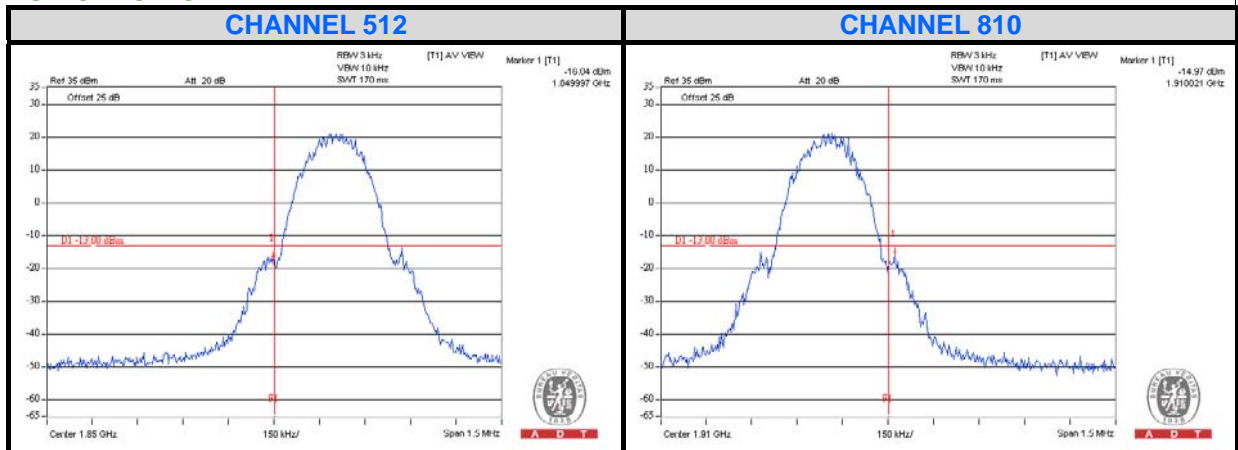

4.5 CONDUCTED SPURIOUS EMISSIONS

4.5.1 LIMITS OF CONDUCTED SPURIOUS EMISSIONS MEASUREMENT

The power of any emission outside of the authorized operating frequency ranges must be attenuated below the transmitting power (P) by a factor of at least $43 + 10 \log(P)$ dB. The emission limit equal to -13dBm .

4.5.2 TEST PROCEDURE

- a. The EUT makes a phone call to the communication simulator. All measurements were done at low, middle and high operational frequency range.
- b. Measuring frequency range is from 9 kHz to 20GHz. 20dB attenuation pad is connected with spectrum. RBW=1MHz and VBW=3MHz is used for conducted emission measurement.

4.5.3 TEST SETUP

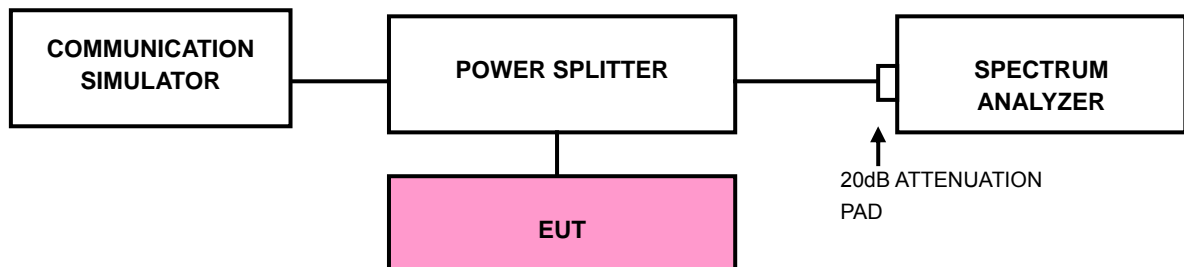

4.5.4 TEST RESULTS

FOR GSM MODE:

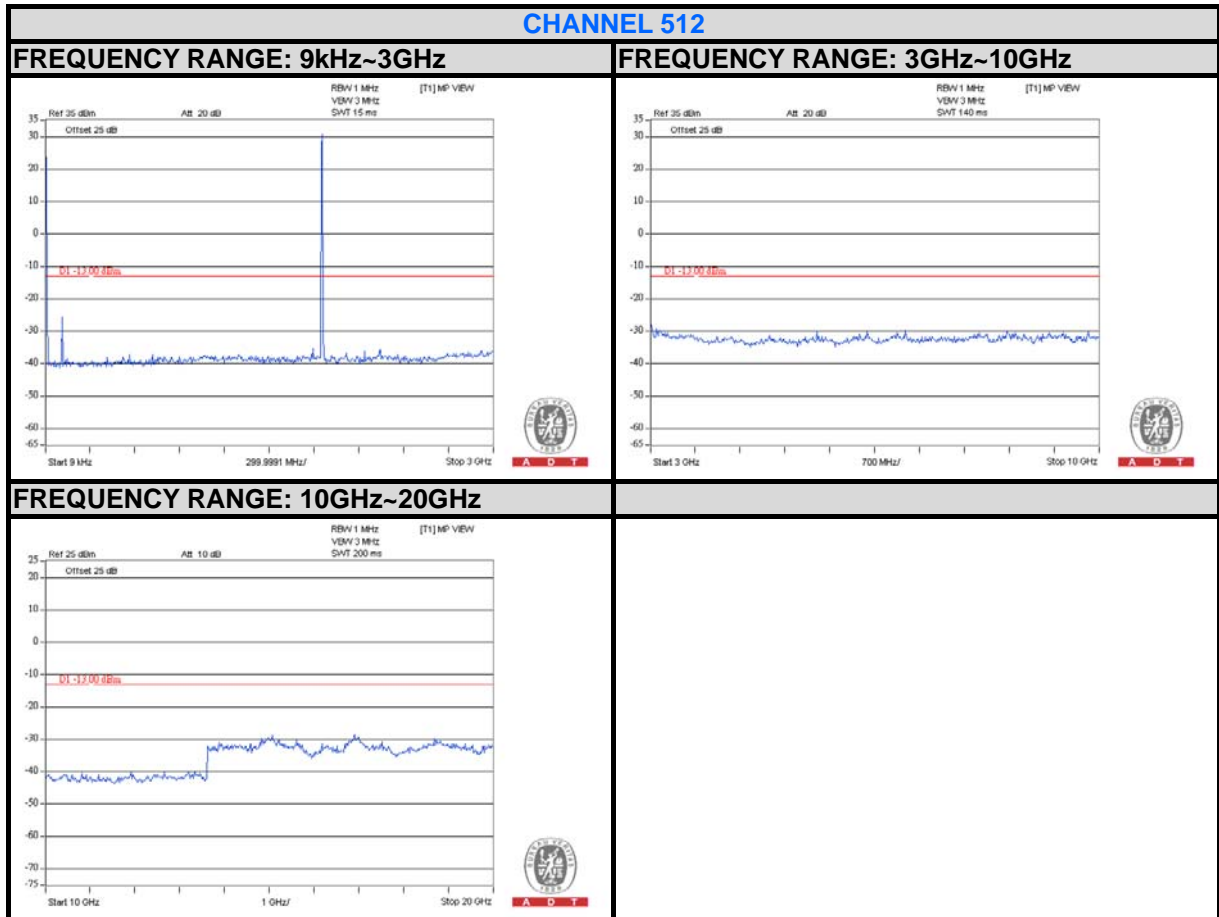



A D T

CHANNEL 661

FREQUENCY RANGE: 9kHz~3GHz

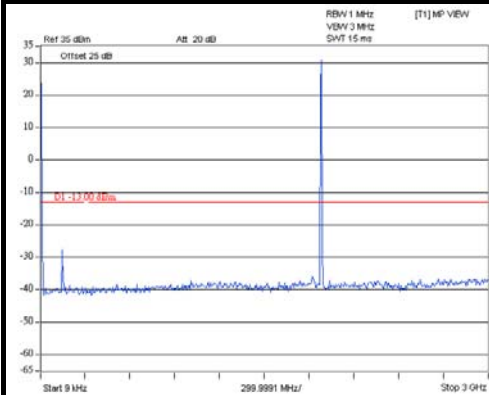

FREQUENCY RANGE: 3GHz~10GHz

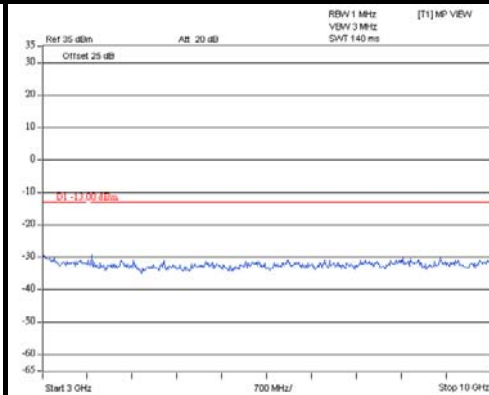

FREQUENCY RANGE: 10GHz~20GHz

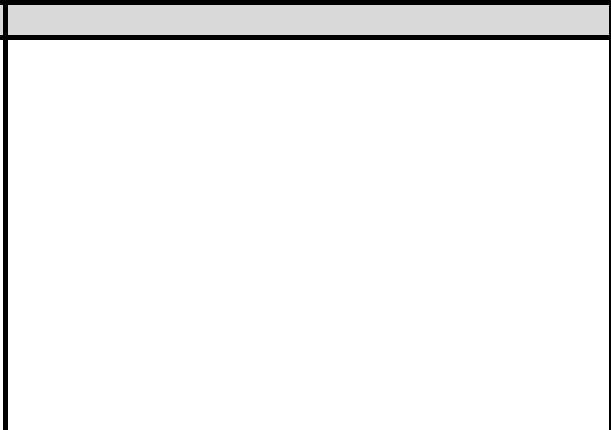
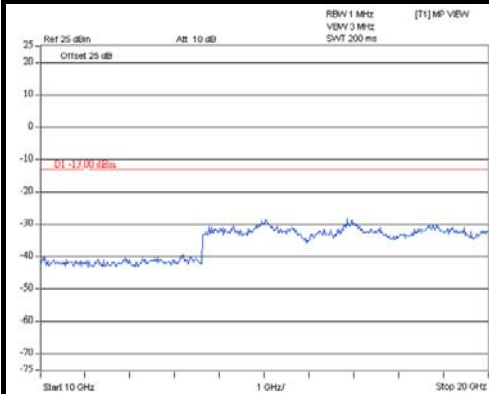



A D T

CHANNEL 810

FREQUENCY RANGE: 9kHz~3GHz

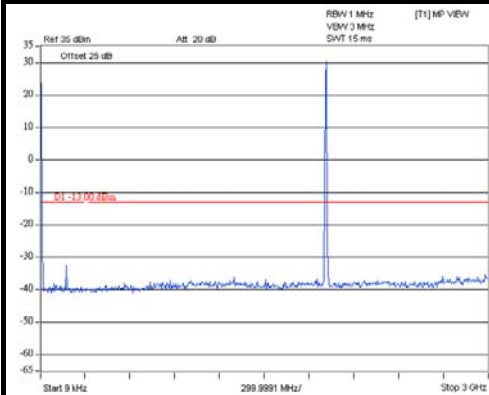

A D T

FREQUENCY RANGE: 3GHz~10GHz

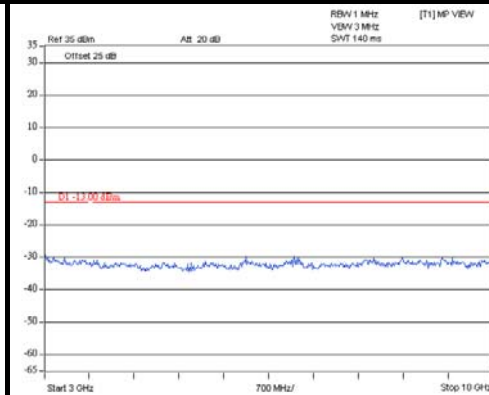

A D T

FREQUENCY RANGE: 10GHz~20GHz

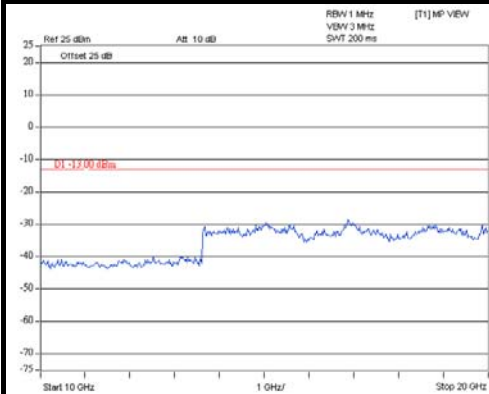

A D T



A D T

FOR GPRS MODE:

CHANNEL 512

FREQUENCY RANGE: 9kHz~3GHz

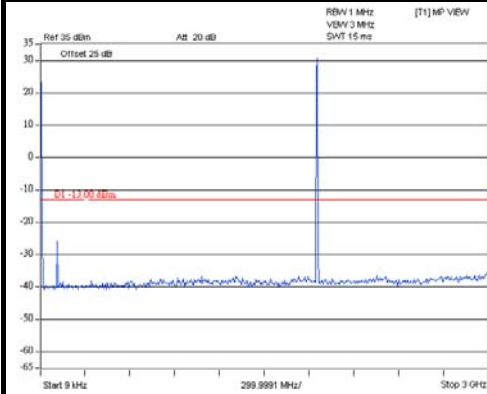

FREQUENCY RANGE: 3GHz~10GHz

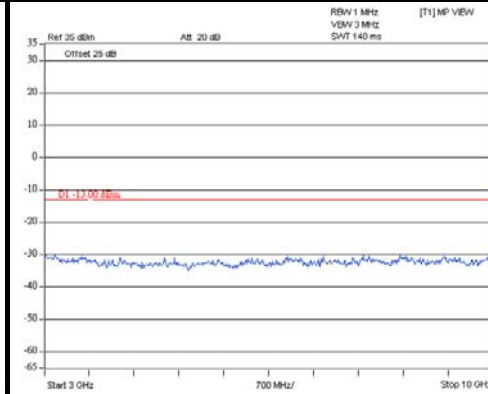

FREQUENCY RANGE: 10GHz~20GHz

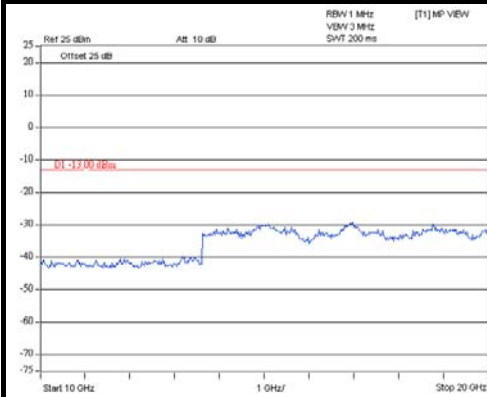



A D T

CHANNEL 661

FREQUENCY RANGE: 9kHz~3GHz

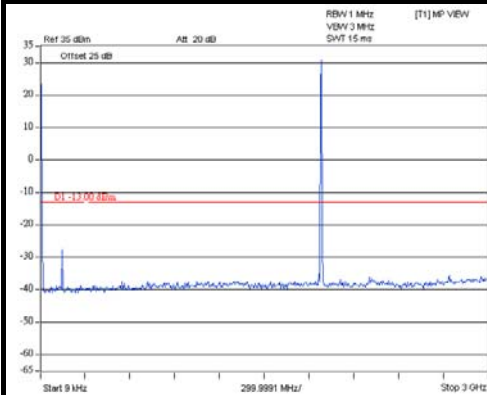

FREQUENCY RANGE: 3GHz~10GHz

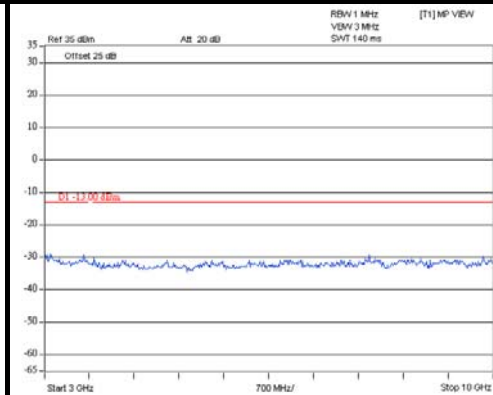

FREQUENCY RANGE: 10GHz~20GHz

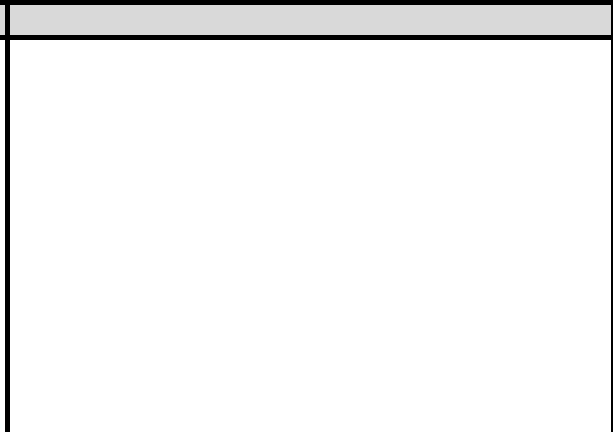
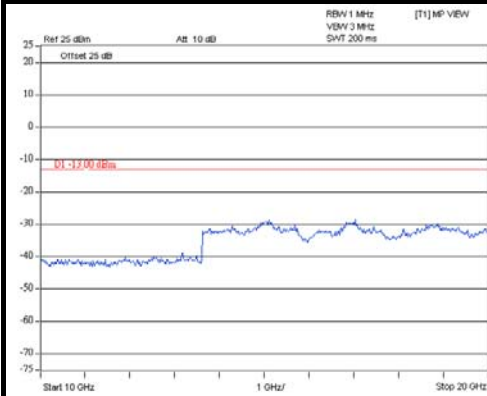



A D T

CHANNEL 810

FREQUENCY RANGE: 9kHz~3GHz

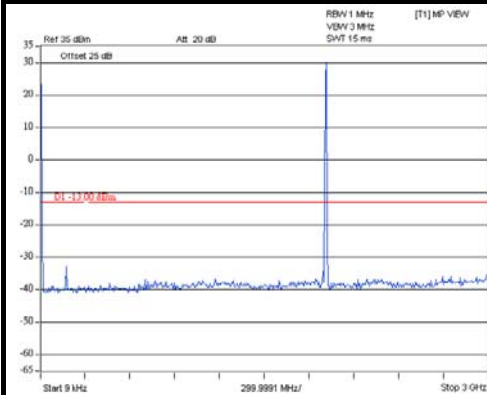

FREQUENCY RANGE: 3GHz~10GHz

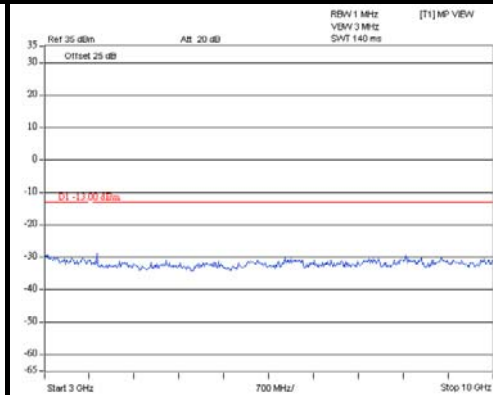

FREQUENCY RANGE: 10GHz~20GHz

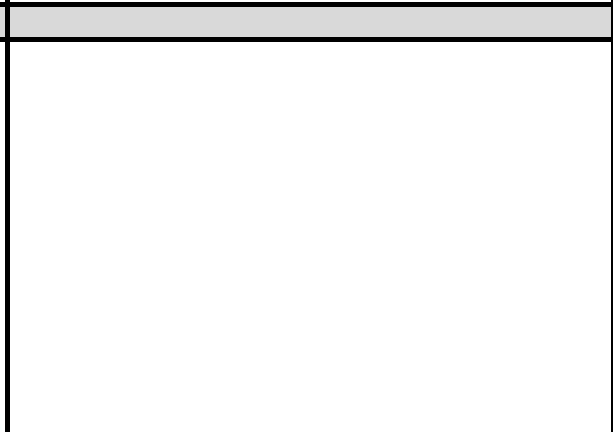
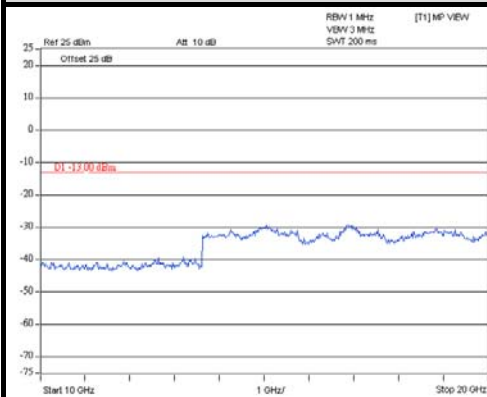

4.6 RADIATED EMISSION MEASUREMENT

4.6.1 LIMITS OF RADIATED EMISSION MEASUREMENT

The power of any emission outside of the authorized operating frequency ranges must be attenuated below the transmitting power (P) by a factor of at least $43 + 10 \log(P)$ dB. The emission limit equal to -13dBm .

4.6.2 TEST PROCEDURES

- a. Substitution method is used for E.I.R.P measurement. In the semi-anechoic chamber, EUT placed on the 0.8m height of Turn Table, rotated the table around 360 degrees to search the maximum radiation power and receiver antenna shall be rotated vertical and horizontal polarization and moved height from 1m to 4m to find the maximum polar radiated power. The “Read Value” is the spectrum reading the maximum power value.
- b. The substitution horn antenna is substituted for EUT at the same position and signals generator export the CW signal to the substitution antenna via a TX cable. Rotated the Turn Table and moved receiving antenna to find the maximum radiation power. Adjust output power level of S.G to get a Value of spectrum reading equal to “Read Value” of step a. Record the power level of S.G
- c. $\text{EIRP} = \text{Output power level of S.G} - \text{TX cable loss} + \text{Antenna gain of substitution horn.}$
- d. E.R.P power can be calculated form E.I.R.P power by subtracting the gain of dipole, $\text{E.R.P power} = \text{E.I.P.R power} - 2.15\text{dBi.}$

NOTE: The resolution bandwidth and video bandwidth of test receiver/spectrum analyzer is 1MHz/3MHz.

4.6.3 DEVIATION FROM TEST STANDARD

No deviation

4.6.4 TEST SETUP

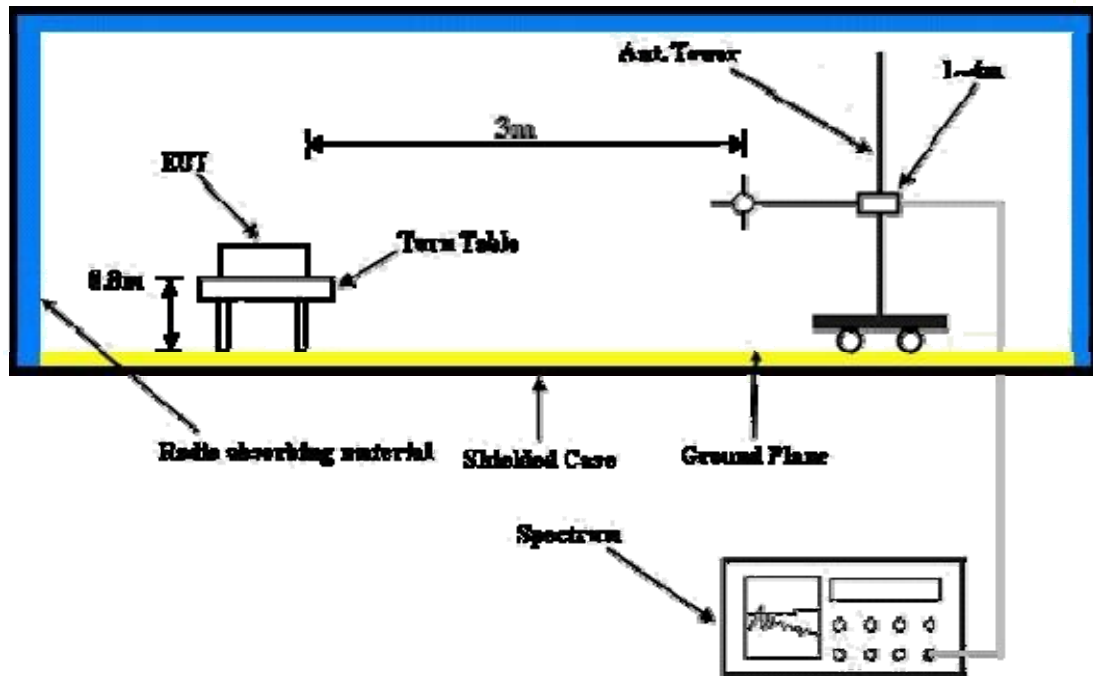

For the actual test configuration, please refer to the attached file (Test Setup Photo).

4.6.5 TEST RESULTS

Below 1GHz

FOR GSM MODE:

MODE	TX channel 512	FREQUENCY RANGE	Below 1000MHz
ENVIRONMENTAL CONDITIONS	25deg. C, 65%RH	INPUT POWER	120Vac, 60 Hz
TESTED BY	Haru Yang		

ANTENNA POLARITY & TEST DISTANCE: HORIZONTAL AT 3 M							
No.	Freq. (MHz)	Reading (dBm)	S.G Power Value (dBm)	Correction Factor (dB)	EIRP (dBm)	Limit (dBm)	Margin (dB)
1	31.9439	-55.4	-39.0	-12.4	-51.4	-13.0	-38.4
2	47.4950	-53.1	-40.6	-10.2	-50.8	-13.0	-37.8
3	84.4289	-48.7	-55.8	-0.4	-56.2	-13.0	-43.2
4	181.6232	-49.3	-58.1	3.1	-55.0	-13.0	-42.0
5	218.5571	-52.0	-63.6	5.5	-58.1	-13.0	-45.1
6	745.3570	-67.9	-67.3	4.7	-62.6	-13.0	-49.6
ANTENNA POLARITY & TEST DISTANCE: VERTICAL AT 3 M							
No.	Freq. (MHz)	Reading (dBm)	S.G Power Value (dBm)	Correction Factor (dB)	EIRP (dBm)	Limit (dBm)	Margin (dB)
1	33.8878	-41.1	-35.7	-12.1	-47.8	-13.0	-34.8
2	64.9900	-40.5	-40.7	-6.3	-47.0	-13.0	-34.0
3	82.4850	-47.5	-50.4	-1.0	-51.4	-13.0	-38.4
4	105.8116	-49.3	-55.4	0.6	-54.8	-13.0	-41.8
5	189.3988	-56.3	-62.2	4.1	-58.1	-13.0	-45.1
6	232.1643	-56.0	-63.5	5.4	-58.1	-13.0	-45.1

REMARKS:

1. Power Value (dBm) = S.G Power Value (dBm) + Correction Factor (dB).
2. Correction Factor (dB) = Substitution Antenna Gain (dB) + Cable Loss (dB).



A D T

Above 1GHz

MODE	Channel 512	FREQUENCY RANGE	Above 1000MHz
INPUT POWER	120Vac, 60 Hz	ENVIRONMENTAL CONDITIONS	25deg. C, 65%RH
TESTED BY	Aska Huang		

ANTENNA POLARITY & TEST DISTANCE: HORIZONTAL AT 3 M

No.	Freq. (MHz)	Reading (dBm)	S.G Power Value (dBm)	Correction Factor (dB)	EIRP (dBm)	Limit (dBm)	Margin (dB)
1	3700.4	-42.5	-38.5	7.2	-31.3	-13.0	-18.3
2	5550.6	-55.4	-44.5	6.8	-37.7	-13.0	-24.7
3	7400.8	-62.2	-45.0	4.3	-40.7	-13.0	-27.7

ANTENNA POLARITY & TEST DISTANCE: VERTICAL AT 3 M

No.	Freq. (MHz)	Reading (dBm)	S.G Power Value (dBm)	Correction Factor (dB)	EIRP (dBm)	Limit (dBm)	Margin (dB)
1	3700.4	-45.0	-41.2	7.2	-34.0	-13.0	-21.0
2	5550.6	-54.6	-45.2	6.8	-38.4	-13.0	-25.4
3	7400.8	-60.9	-44.4	4.3	-40.1	-13.0	-27.1

REMARKS:

1. Power Value (dBm) = S.G Power Value (dBm) + Correction Factor (dB).
2. Correction Factor (dB) = Substitution Antenna Gain (dB) + Cable Loss (dB).



A D T

MODE	Channel 661	FREQUENCY RANGE	Above 1000MHz
INPUT POWER	120Vac, 60 Hz	ENVIRONMENTAL CONDITIONS	25deg. C, 65%RH
TESTED BY	Haru Yang		

ANTENNA POLARITY & TEST DISTANCE: HORIZONTAL AT 3 M							
No.	Freq. (MHz)	Reading (dBm)	S.G Power Value (dBm)	Correction Factor (dB)	EIRP (dBm)	Limit (dBm)	Margin (dB)
1	3760.0	-45.7	-41.3	7.1	-34.2	-13.0	-21.2
2	5640.0	-56.3	-45.3	6.8	-38.5	-13.0	-25.5
3	7520.0	-60.6	-43.0	4.2	-38.8	-13.0	-25.8

ANTENNA POLARITY & TEST DISTANCE: VERTICAL AT 3 M							
No.	Freq. (MHz)	Reading (dBm)	S.G Power Value (dBm)	Correction Factor (dB)	EIRP (dBm)	Limit (dBm)	Margin (dB)
1	3760.0	-41.5	-37.5	7.1	-30.4	-13.0	-17.4
2	5640.0	-57.3	-47.6	6.8	-40.8	-13.0	-27.8
3	7520.0	-60.7	-43.9	4.2	-39.7	-13.0	-26.7

REMARKS:

1. Power Value (dBm) = S.G Power Value (dBm) + Correction Factor (dB).
2. Correction Factor (dB) = Substitution Antenna Gain (dB) + Cable Loss (dB).



A D T

MODE	Channel 810	FREQUENCY RANGE	Above 1000MHz
INPUT POWER	120Vac, 60 Hz	ENVIRONMENTAL CONDITIONS	25deg. C, 65%RH
TESTED BY	Haru Yang		

ANTENNA POLARITY & TEST DISTANCE: HORIZONTAL AT 3 M

No.	Freq. (MHz)	Reading (dBm)	S.G Power Value (dBm)	Correction Factor (dB)	EIRP (dBm)	Limit (dBm)	Margin (dB)
1	3819.6	-45.8	-41.2	7.1	-34.1	-13.0	-21.1
2	5729.4	-58.1	-47.0	6.7	-40.3	-13.0	-27.3
3	7639.2	-60.5	-42.7	4.2	-38.5	-13.0	-25.5

ANTENNA POLARITY & TEST DISTANCE: VERTICAL AT 3 M

No.	Freq. (MHz)	Reading (dBm)	S.G Power Value (dBm)	Correction Factor (dB)	EIRP (dBm)	Limit (dBm)	Margin (dB)
1	3819.6	-45.1	-41.0	7.1	-33.9	-13.0	-20.9
2	5729.4	-55.6	-45.4	6.7	-38.7	-13.0	-25.7
3	7639.2	-61.8	-44.9	4.2	-40.7	-13.0	-27.7

REMARKS:

1. Power Value (dBm) = S.G Power Value (dBm) + Correction Factor (dB).
2. Correction Factor (dB) = Substitution Antenna Gain (dB) + Cable Loss (dB).



A D T

5 PHOTOGRAPHS OF THE TEST CONFIGURATION

Please refer to the attached file (Test Setup Photo).





6 INFORMATION ON THE TESTING LABORATORIES

We, Bureau Veritas Consumer Products Services (H.K.) Ltd., Taoyuan Branch, were founded in 1988 to provide our best service in EMC, Radio, Telecom and Safety consultation. Our laboratories are accredited and approved according to ISO/IEC 17025.

Copies of accreditation and authorization certificates of our laboratories obtained from approval agencies can be downloaded from our web site:

www.adt.com.tw/index.5.phtml. If you have any comments, please feel free to contact us at the following:

Linko EMC/RF Lab:

Tel: 886-2-26052180

Fax: 886-2-26051924

Hsin Chu EMC/RF Lab:

Tel: 886-3-5935343

Fax: 886-3-5935342

Hwa Ya EMC/RF/Safety/Telecom Lab:

Tel: 886-3-3183232

Fax: 886-3-3270892

Email: service.adt@tw.bureauveritas.com

Web Site: www.adt.com.tw

The address and road map of all our labs can be found in our web site also.



A D T

7 APPENDIX A – MODIFICATIONS RECORDERS FOR ENGINEERING CHANGES TO THE EUT BY THE LAB

No any modifications are made to the EUT by the lab during the test.

---END---