



FCC CERTIFICATION TEST REPORT

REPORT NO.: FD110811C11A
MODEL NO.: F-09D
RECEIVED: Aug. 11, 2011
TESTED: Sep. 23 ~ Oct. 07, 2011 (Original test)
Mar. 26 ~ Mar. 27, 2012 (GPS Mode)
ISSUED: Mar. 28, 2012

APPLICANT: FUJITSU LIMITED

ADDRESS: 1-1, Kamikodanaka 4-chome, Nakahara-ku,
Kawasaki 211-8588, Japan

ISSUED BY: Bureau Veritas Consumer Products Services (H.K.)
Ltd., Taoyuan Branch

LAB ADDRESS: No. 47, 14th Ling, Chia Pau Vil., Lin Kou Dist., New
Taipei City, Taiwan (R.O.C.)

TEST LOCATION: No. 19, Hwa Ya 2nd Rd, Wen Hwa Tsuen, Kwei
Shan Hsiang, Taoyuan Hsien 333, Taiwan, R.O.C.

This test report consists of 36 pages in total. It may be duplicated completely for legal use with the approval of the applicant. It should not be reproduced except in full, without the written approval of our laboratory. The client should not use it to claim product, certification, approval or endorsement by TAF or any government agency. The test results in the report only apply to the tested sample. The test results in this report are traceable to the national or international standards.





Table of Contents

RELEASE CONTROL RECORD.....	3
1. CERTIFICATION.....	4
2. SUMMARY OF TEST RESULTS	5
2.1 MEASUREMENT UNCERTAINTY.....	5
3. GENERAL INFORMATION.....	6
3.1 GENERAL DESCRIPTION OF EUT.....	6
3.2 DESCRIPTION OF TEST MODES.....	8
3.2.1 CONFIGURATION OF SYSTEM UNDER TEST	8
3.3 DESCRIPTION OF SUPPORT UNITS	9
3.4 GENERAL DESCRIPTION OF APPLIED STANDARDS.....	9
4. TEST TYPES AND RESULTS	10
4.1 RADIATED EMISSION MEASUREMENT	10
4.1.1 LIMITS OF RADIATED EMISSION MEASUREMENT	10
4.1.2 TEST INSTRUMENTS.....	11
4.1.3 TEST PROCEDURES	13
4.1.4 DEVIATION FROM TEST STANDARD	13
4.1.5 TEST SETUP.....	14
4.1.6 EUT OPERATING CONDITIONS	14
4.1.7 TEST RESULTS	15
4.2 CONDUCTED EMISSION MEASUREMENT	23
4.2.1 LIMITS OF CONDUCTED EMISSION MEASUREMENT	23
4.2.2 TEST INSTRUMENTS.....	24
4.2.3 TEST PROCEDURES	25
4.2.4 DEVIATION FROM TEST STANDARD	25
4.2.5 TEST SETUP.....	25
4.2.6 EUT OPERATING CONDITIONS	25
4.2.7 TEST RESULTS	26
5. PHOTOGRAPHS OF THE TEST CONFIGURATION.....	34
6. INFORMATION ON THE TESTING LABORATORIES.....	35
7. APPENDIX A - MODIFICATIONS RECORDERS FOR ENGINEERING CHANGES TO THE EUT BY THE LAB	36



RELEASE CONTROL RECORD

ISSUE NO.	REASON FOR CHANGE	DATE ISSUED
FD110811C11A	Original release	Mar. 28, 2012



1. CERTIFICATION

PRODUCT: Mobile Phone

MODEL: F-09D

BRAND: FOMA

APPLICANT: FUJITSU LIMITED

TEST SAMPLE: ENGINEERING SAMPLE

TESTED: Sep. 23 ~ Oct. 07, 2011 (Original test)

Mar. 26 ~ Mar. 27, 2012 (GPS Mode)

STANDARDS: FCC Part 15, Subpart B, Class B

The above equipment (Model: F-09D) has been tested by **Bureau Veritas Consumer Products Services (H.K.) Ltd., Taoyuan Branch**, and found compliance with the requirement of the above standards. The test record, data evaluation & Equipment Under Test (EUT) configurations represented herein are true and accurate accounts of the measurements of the sample's EMC characteristics under the conditions specified in this report.

PREPARED BY : , DATE : Mar. 28, 2012
Polly Chien / Specialist

APPROVED BY : , DATE : Mar. 28, 2012
Gary Chang / Technical Manager

2. SUMMARY OF TEST RESULTS

The EUT has been tested according to the following specifications:

Standard Section	Test Type	Result	Remark
FCC Part 15, Subpart B, Class B	Conducted Emission	PASS	Meet the requirement of limit. Minimum passing margin is -13.73dB at 3.32813MHz.
	Radiated Emission	PASS	Meet the requirement of limit. Minimum passing margin is -4.2dB at 832.89MHz.

2.1 MEASUREMENT UNCERTAINTY

Where relevant, the following measurement uncertainty levels have been estimated for tests performed on the EUT as specified in CISPR 16-4-2:

MEASUREMENT	FREQUENCY	UNCERTAINTY
Conducted emissions	150kHz~30MHz	2.44 dB
Radiated emissions	30MHz ~ 200MHz	3.34 dB
	200MHz ~1000MHz	3.35 dB
	1GHz ~ 18GHz	2.26 dB
	18GHz ~ 40GHz	1.94 dB

This uncertainty represents an expanded uncertainty expressed at approximately the 95% confidence level using a coverage factor of k=2.

3. GENERAL INFORMATION

3.1 GENERAL DESCRIPTION OF EUT

EUT	Mobile Phone	
MODEL NO.	F-09D	
POWER SUPPLY	3.7Vdc (Li-ion battery) 5.4Vdc (Adapter)	
MODULATION TYPE	WLAN	CCK, DQPSK, DBPSK for DSSS 64QAM, 16QAM, QPSK, BPSK for OFDM
	BLUETOOTH	GFSK, $\pi/4$ -DQPSK, 8DPSK
	RFID	ASK
	GSM, GPRS	GMSK
	WCDMA	BPSK
	GPS	C/A code
FREQUENCY RANGE	WLAN	2412 ~ 2462MHz
	BLUETOOTH	2402 ~ 2480MHz
	RFID	13.56MHz
	WCDMA 850	826.4MHz ~ 846.6MHz
	GSM 850	824.2MHz ~ 848.8MHz
	GPRS 1900	1850.2MHz ~ 1909.8MHz
	GPS	1575.42 MHz
ANTENNA TYPE	WLAN	$\lambda/4$ Monopole Antenna with -5.0dBi gain
	BLUETOOTH	$\lambda/4$ Monopole Antenna with -5.0dBi gain
	RFID	Loop antenna
	WCDMA 850	$\lambda/4$ Monopole antenna with -7.7dBi gain
	GSM 850	$\lambda/4$ Monopole antenna with -7.7dBi gain
	GPRS 1900	$\lambda/4$ Monopole antenna with -2.9dBi gain
	GPS	$\lambda/4$ Monopole antenna
DATA CABLE	NA	
I/O PORTS	Refer to user's manual	
ACCESSORY DEVICES	Battery	

NOTE:

1. This report is issued as a supplementary report to the original BV ADT report No.: FD110811C11. The differences are changing model name and adding GPS function. Therefore, we tested GPS mode and presented the test result in the test report.
2. The EUT use the following internal Li-ion battery:

BRAND	Fujitsu Limited
MODEL	F23
RATING	3.7Vdc, 1460mAh, 5.4Wh

3. The following accessories are for support units only.

PRODUCT	BRAND	DESCRIPTION
Adapter	SMK	I/P: 100-240Vac, 0.12A, 50-60Hz O/P: 5.4Vdc, 700mA
USB cable	NA	0.8m non-shielded cable without core

4. SW: R09.5
5. HW: V2.1.0
6. IMEI Code: 358202040012205(for others), 359162040010832(for GPS).
7. The EUT provides one completed transmitter and one receiver for WLAN.

MODULATION MODE	TX FUNCTION
802.11b	1TX
802.11g	1TX
802.11n (20MHz)	1TX

8. The above EUT information is declared by manufacturer and for more detailed features description, please refer to the manufacturer's specifications or User's Manual.

3.2 DESCRIPTION OF TEST MODES

Test modes are presented in the report as below.

TEST MODE	DESCRIPTION
A	USB R/W + Idle mode: WiFi/ BT/ WCDMA850
B	USB R/W + Idle mode: WiFi/ BT/ GSM850
C	USB R/W + Idle mode: WiFi/ BT/ GSM1900
D	GPS Mode

*For radiated emission test, the EUT has been pre-tested X, Y & Z axis, found USB R/W mode X axis is the worst mode and GPS mode Z axis is the worst mode.

3.2.1 CONFIGURATION OF SYSTEM UNDER TEST

TEST MODE A, B, C

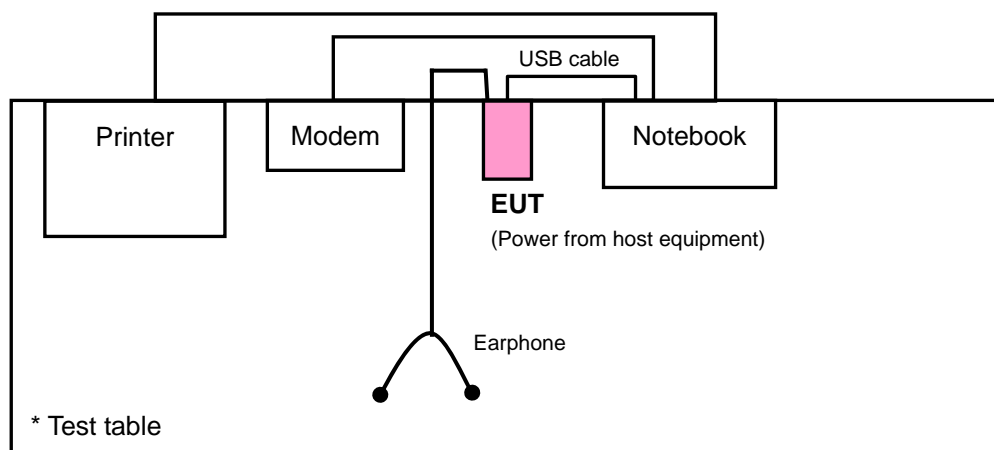

TEST MODE D

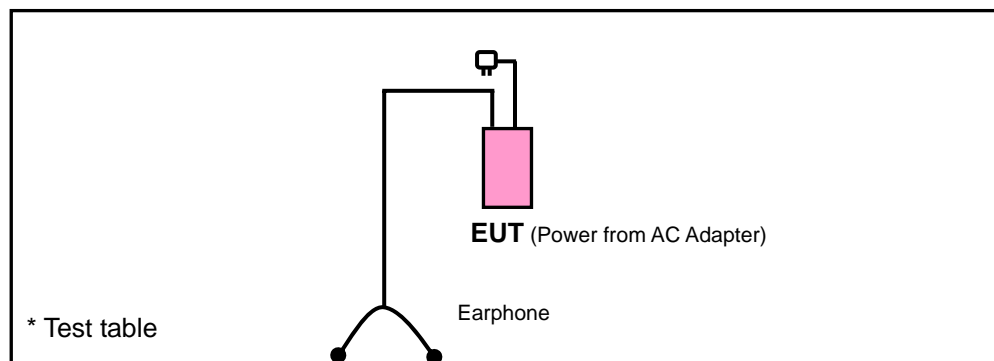



3.3 DESCRIPTION OF SUPPORT UNITS

The EUT has been tested as an independent unit together with other necessary accessories or support units. The following support units or accessories were used to form a representative test configuration during the tests.

NO.	PRODUCT	BRAND	MODEL NO.	SERIAL NO.	FCC ID
1	NOTEBOOK	HP	NC6000	CNU4110Y3V	NA
2	MODEM	ACEEX	1414V/3	0401008270	IFAXDM1414
3	PRINTER	EPSON	LQ-300+	DCGY047265	FCC DoC Approved

NO.	SIGNAL CABLE DESCRIPTION OF THE ABOVE SUPPORT UNITS
1	0.8m USB cable.
2	1.2m braid shielded wire, DB25 & DB9 connector, w/o core.
3	1.8m braid shielded wire, DB25 connector, w/o core.

NOTE:

1. All power cords of the above support units are non shielded (1.8m).
2. The USB cable was supplied from the client.

3.4 GENERAL DESCRIPTION OF APPLIED STANDARDS

The EUT is a RF Product. According to the specifications of the manufacturer, it must comply with the requirements of the following standards:

FCC Part 15, Subpart B, Class B

ANSI C63.4:2003

All test items have been performed and recorded as per the above standards.

4. TEST TYPES AND RESULTS

4.1 RADIATED EMISSION MEASUREMENT

4.1.1 LIMITS OF RADIATED EMISSION MEASUREMENT

Emissions radiated outside of the specified bands, shall be according to the general radiated limits in 15.109 as following:

FREQUENCIES (MHz)	FIELD STRENGTH (microvolts/meter)	MEASUREMENT DISTANCE (meters)
30 ~ 88	100	3
88 ~ 216	150	3
216 ~ 960	200	3
Above 960	500	3

NOTE:

1. The lower limit shall apply at the transition frequencies.
2. Emission level (dBuV/m) = 20 log Emission level (uV/m).
3. As shown in 15.35(b), for frequencies above 1000MHz, the field strength limits are based on average detector, however, the peak field strength of any emission shall not exceed the maximum permitted average limits, specified above by more than 20dB under any condition of modulation.



4.1.2 TEST INSTRUMENTS

FOR TEST MODE A, B, C

DESCRIPTION & MANUFACTURER	MODEL NO.	SERIAL NO.	DATE OF CALIBRATION	DUE DATE OF CALIBRATION
Test Receiver ROHDE & SCHWARZ	ESIB7	100212	Aug. 02, 2011	Aug. 01, 2012
Spectrum Analyzer ROHDE & SCHWARZ	FSP 40	100041	Jul. 21, 2011	Jul. 20, 2012
BILOG Antenna SCHWARZBECK	VULB9168	9168-160	Apr. 13, 2011	Apr. 12, 2012
HORN Antenna SCHWARZBECK	9120D	209	Aug. 25, 2011	Aug. 24, 2012
HORN Antenna SCHWARZBECK	BBHA 9170	BBHA9170243	Dec. 27, 2010	Dec. 26, 2011
Preamplifier Agilent	8447D	2944A10633	Nov. 02, 2010	Nov. 01, 2011
Preamplifier Agilent	8449B	3008A01964	Nov. 02, 2010	Nov. 01, 2011
RF signal cable HUBER+SUHNNER	SUCOFLEX 104	295014/4	Aug. 19, 2011	Aug. 18, 2012
RF signal cable HUBER+SUHNNER	SUCOFLEX 104	12738/6	Aug. 19, 2011	Aug. 18, 2012
Software ADT.	ADT_Radiated_ V7.6.15.9.2	NA	NA	NA
Antenna Tower inn-co GmbH	MA 4000	013303	NA	NA
Antenna Tower Controller inn-co GmbH	CO2000	017303	NA	NA
Turn Table ADT.	TT100.	TT93021703	NA	NA
Turn Table Controller ADT.	SC100.	SC93021703	NA	NA

- NOTE:**
1. The calibration interval of the above test instruments is 12 months and the calibrations are traceable to NML/ROC and NIST/USA.
 2. The test was performed in HwaYa Chamber 3.
 3. The horn antenna and HP preamplifier (model: 8449B) are used only for the measurement of emission frequency above 1GHz if tested.
 4. The FCC Site Registration No. is 988962.
 5. The IC Site Registration No. is IC 7450F-3.



A D T

FOR TEST MODE D

DESCRIPTION & MANUFACTURER	MODEL NO.	SERIAL NO.	DATE OF CALIBRATION	DUE DATE OF CALIBRATION
Test Receiver ROHDE & SCHWARZ	ESIB7	100212	Aug. 02, 2011	Aug. 01, 2012
Spectrum Analyzer ROHDE & SCHWARZ	FSP40	100041	Jul. 21, 2011	Jul. 20, 2012
BILOG Antenna SCHWARZBECK	VULB9168	9168-160	Apr. 13, 2011	Apr. 12, 2012
HORN Antenna SCHWARZBECK	9120D	209	Aug. 25, 2011	Aug. 24, 2012
HORN Antenna SCHWARZBECK	BBHA 9170	148	Jul. 20, 2011	Jul. 19, 2012
Preamplifier Agilent	8447D	2944A10633	Oct. 29, 2011	Oct. 28, 2012
Preamplifier Agilent	8449B	3008A01964	Oct. 29, 2011	Oct. 28, 2012
RF signal cable HUBER+SUHNNER	SUCOFLEX 104	250723/4	Aug. 30, 2011	Aug. 29, 2012
RF signal cable HUBER+SUHNNER	SUCOFLEX 106	12738/6+309224/ 4	Aug. 30, 2011	Aug. 29, 2012
Software ADT.	ADT_Radiated_ V7.6.15.9.2	NA	NA	NA
Antenna Tower inn-co GmbH	MA 4000	013303	NA	NA
Antenna Tower Controller inn-co GmbH	CO2000	017303	NA	NA
Turn Table ADT.	TT100	TT93021703	NA	NA
Turn Table Controller ADT.	SC100	SC93021703	NA	NA

- NOTE:**
1. The calibration interval of the above test instruments is 12 months and the calibrations are traceable to NML/ROC and NIST/USA.
 2. The test was performed in HwaYa Chamber 3.
 3. The horn antenna and HP preamplifier (model: 8449B) are used only for the measurement of emission frequency above 1GHz if tested.
 4. The FCC Site Registration No. is 988962.
 5. The IC Site Registration No. is IC 7450F-3.

4.1.3 TEST PROCEDURES

- a. The EUT was placed on the top of a rotating table 0.8 meters above the ground at a 3 meter semi-anechoic chamber. The table was rotated 360 degrees to determine the position of the highest radiation.
- b. The EUT was set 3 meters away from the interference-receiving antenna, which was mounted on the top of a variable-height antenna tower.
- c. The antenna is a broadband antenna, and its height is varied from one meter to four meters above the ground to determine the maximum value of the field strength. Both horizontal and vertical polarizations of the antenna are set to make the measurement.
- d. For each suspected emission, the EUT was arranged to its worst case and then the antenna was tuned to heights from 1 meter to 4 meters and the rotatable table was turned from 0 degrees to 360 degrees to find the maximum reading.
- e. The test-receiver system was set to Peak Detect Function and Specified Bandwidth with Maximum Hold Mode.
- f. If the emission level of the EUT in peak mode was lower than the limit specified, then testing could be stopped and the peak values of the EUT would be reported. Otherwise the emissions would be re-tested one by one using peak, quasi-peak or average method as specified and then reported in a data sheet.

NOTE:

1. The resolution bandwidth and video bandwidth of test receiver/spectrum analyzer is 120kHz for Quasi-peak detection at frequency below 1GHz.
2. The resolution bandwidth of test receiver/spectrum analyzer is 1 MHz and video bandwidth is 3MHz for Peak detection at frequency above 1GHz.
3. All modes of operation were investigated and the worst-case emissions are reported.

4.1.4 DEVIATION FROM TEST STANDARD

No deviation.

4.1.5 TEST SETUP

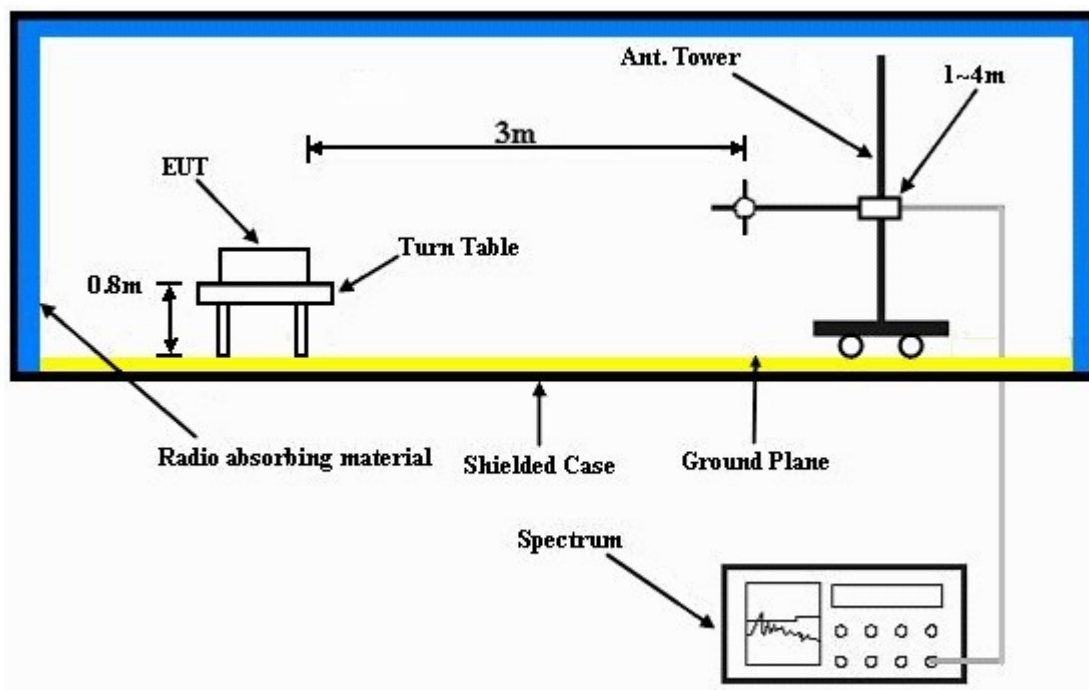

For the actual test configuration, please refer to the attached file (Test Setup Photo).

4.1.6 EUT OPERATING CONDITIONS

FOR TEST MODE A, B, C

- Connected the EUT to a notebook and placed on a testing table.
- Set WiFi/ Bluetooth/ WWAN in idle mode.
- The notebook executes EMC TEST tool to read data and write data to microSD of EUT via USB cable.
- The necessary accessories enable the system in full functions.

TEST MODE D

Enable EUT under receiving condition continuously at specific channel frequency.

4.1.7 TEST RESULTS

ABOVE 1GHz DATA :

EUT TEST CONDITION		MEASUREMENT DETAIL	
INPUT POWER (SYSTEM)	120Vac, 60Hz	FREQUENCY RANGE	1 ~ 12.5GHz
ENVIRONMENTAL CONDITIONS	25deg. C, 65%RH	DETECTOR FUNCTION	Peak (PK) Average (AV)
TESTED BY	David Huang	TEST MODE	A

ANTENNA POLARITY & TEST DISTANCE: HORIZONTAL AT 3 M								
NO.	FREQ. (MHz)	EMISSION LEVEL (dBuV/m)	LIMIT (dBuV/m)	MARGIN (dB)	ANTENNA HEIGHT (m)	TABLE ANGLE (Degree)	RAW VALUE (dBuV)	CORRECTION FACTOR (dB/m)
1	1637.00	41.3 PK	74.0	-32.7	1.00 H	143	12.30	29.00
2	1637.00	28.9 AV	54.0	-25.1	1.00 H	143	-0.10	29.00
3	2130.00	38.2 PK	74.0	-35.8	1.00 H	108	8.10	30.10
4	2130.00	24.1 AV	54.0	-29.9	1.00 H	108	-6.00	30.10
5	3260.00	45.7 PK	74.0	-28.3	1.00 H	241	12.50	33.20
6	3260.00	31.8 AV	54.0	-22.2	1.00 H	241	-1.40	33.20
ANTENNA POLARITY & TEST DISTANCE: VERTICAL AT 3 M								
NO.	FREQ. (MHz)	EMISSION LEVEL (dBuV/m)	LIMIT (dBuV/m)	MARGIN (dB)	ANTENNA HEIGHT (m)	TABLE ANGLE (Degree)	RAW VALUE (dBuV)	CORRECTION FACTOR (dB/m)
1	1637.00	40.0 PK	74.0	-34.0	1.10 V	128	11.00	29.00
2	1637.00	27.1 AV	54.0	-26.9	1.10 V	128	-1.90	29.00
3	2130.00	39.3 PK	74.0	-34.7	1.00 V	183	9.20	30.10
4	2130.00	25.6 AV	54.0	-28.4	1.00 V	183	-4.50	30.10
5	3260.00	44.5 PK	74.0	-29.5	1.00 V	117	11.30	33.20
6	3260.00	30.6 AV	54.0	-23.4	1.00 V	117	-2.60	33.20

- REMARKS:**
1. Emission level (dBuV/m) = Raw Value (dBuV) + Correction Factor (dB/m).
 2. Correction Factor (dB/m) = Antenna Factor (dB/m) + Cable Factor (dB).
 3. The other emission levels were very low against the limit.
 4. Margin value = Emission level – Limit value.



A D T

EUT TEST CONDITION		MEASUREMENT DETAIL	
INPUT POWER (SYSTEM)	120Vac, 60Hz	FREQUENCY RANGE	1 ~ 12.5GHz
ENVIRONMENTAL CONDITIONS	25deg. C, 65%RH	DETECTOR FUNCTION	Peak (PK) Average (AV)
TESTED BY	David Huang	TEST MODE	B

ANTENNA POLARITY & TEST DISTANCE: HORIZONTAL AT 3 M								
NO.	FREQ. (MHz)	EMISSION LEVEL (dBuV/m)	LIMIT (dBuV/m)	MARGIN (dB)	ANTENNA HEIGHT (m)	TABLE ANGLE (Degree)	RAW VALUE (dBuV)	CORRECTION FACTOR (dB/m)
1	1637.00	41.7 PK	74.0	-32.3	1.00 H	156	12.70	29.00
2	1637.00	29.4 AV	54.0	-24.6	1.00 H	156	0.40	29.00
3	2130.00	38.7 PK	74.0	-35.3	1.00 H	178	8.60	30.10
4	2130.00	24.4 AV	54.0	-29.6	1.00 H	178	-5.70	30.10
5	3260.00	45.9 PK	74.0	-28.1	1.00 H	298	12.70	33.20
6	3260.00	32.5 AV	54.0	-21.5	1.00 H	298	-0.70	33.20
ANTENNA POLARITY & TEST DISTANCE: VERTICAL AT 3 M								
NO.	FREQ. (MHz)	EMISSION LEVEL (dBuV/m)	LIMIT (dBuV/m)	MARGIN (dB)	ANTENNA HEIGHT (m)	TABLE ANGLE (Degree)	RAW VALUE (dBuV)	CORRECTION FACTOR (dB/m)
1	1637.00	40.2 PK	74.0	-33.8	1.00 V	251	11.20	29.00
2	1637.00	28.1 AV	54.0	-25.9	1.00 V	251	-0.90	29.00
3	2130.00	37.4 PK	74.0	-36.6	1.00 V	108	7.30	30.10
4	2130.00	23.3 AV	54.0	-30.7	1.00 V	108	-6.80	30.10
5	3260.00	44.1 PK	74.0	-29.9	1.00 V	312	10.90	33.20
6	3260.00	31.2 AV	54.0	-22.8	1.00 V	312	-2.00	33.20

- REMARKS:**
1. Emission level (dBuV/m) = Raw Value (dBuV) + Correction Factor (dB/m).
 2. Correction Factor (dB/m) = Antenna Factor (dB/m) + Cable Factor (dB).
 3. The other emission levels were very low against the limit.
 4. Margin value = Emission level – Limit value.



A D T

EUT TEST CONDITION		MEASUREMENT DETAIL	
INPUT POWER (SYSTEM)	120Vac, 60Hz	FREQUENCY RANGE	1 ~ 12.5GHz
ENVIRONMENTAL CONDITIONS	25deg. C, 65%RH	DETECTOR FUNCTION	Peak (PK) Average (AV)
TESTED BY	David Huang	TEST MODE	C

ANTENNA POLARITY & TEST DISTANCE: HORIZONTAL AT 3 M								
NO.	FREQ. (MHz)	EMISSION LEVEL (dBuV/m)	LIMIT (dBuV/m)	MARGIN (dB)	ANTENNA HEIGHT (m)	TABLE ANGLE (Degree)	RAW VALUE (dBuV)	CORRECTION FACTOR (dB/m)
1	1750.00	42.5 PK	74.0	-31.5	1.00 H	214	13.30	29.20
2	1750.00	30.7 AV	54.0	-23.3	1.00 H	214	1.50	29.20
3	2130.00	39.8 PK	74.0	-34.2	1.00 H	112	9.70	30.10
4	2130.00	25.8 AV	54.0	-28.2	1.00 H	112	-4.30	30.10
5	3260.00	46.9 PK	74.0	-27.1	1.00 H	17	13.70	33.20
6	3260.00	34.6 AV	54.0	-19.4	1.00 H	17	1.40	33.20
ANTENNA POLARITY & TEST DISTANCE: VERTICAL AT 3 M								
NO.	FREQ. (MHz)	EMISSION LEVEL (dBuV/m)	LIMIT (dBuV/m)	MARGIN (dB)	ANTENNA HEIGHT (m)	TABLE ANGLE (Degree)	RAW VALUE (dBuV)	CORRECTION FACTOR (dB/m)
1	1750.00	41.3 PK	74.0	-32.7	1.00 V	141	12.10	29.20
2	1750.00	29.6 AV	54.0	-24.4	1.00 V	141	0.40	29.20
3	2130.00	38.8 PK	74.0	-35.2	1.00 V	215	8.70	30.10
4	2130.00	24.8 AV	54.0	-29.2	1.00 V	215	-5.30	30.10
5	3260.00	45.7 PK	74.0	-28.3	1.00 V	265	12.50	33.20
6	3260.00	33.7 AV	54.0	-20.3	1.00 V	265	0.50	33.20

- REMARKS:**
1. Emission level (dBuV/m) = Raw Value (dBuV) + Correction Factor (dB/m).
 2. Correction Factor (dB/m) = Antenna Factor (dB/m) + Cable Factor (dB).
 3. The other emission levels were very low against the limit.
 4. Margin value = Emission level – Limit value.



A D T

EUT TEST CONDITION		MEASUREMENT DETAIL	
INPUT POWER	120Vac, 60 Hz	FREQUENCY RANGE	1 ~ 12.5GHz
ENVIRONMENTAL CONDITIONS	25deg. C, 65%RH	DETECTOR FUNCTION	Peak (PK) Average (AV)
TESTED BY	Aska Huang	TEST MODE	D

ANTENNA POLARITY & TEST DISTANCE: HORIZONTAL AT 3 M								
NO.	FREQ. (MHz)	EMISSION LEVEL (dBuV/m)	LIMIT (dBuV/m)	MARGIN (dB)	ANTENNA HEIGHT (m)	TABLE ANGLE (Degree)	RAW VALUE (dBuV)	CORRECTION FACTOR (dB/m)
1	1575.42	37.0 PK	74.0	-37.0	1.00 H	169	7.90	29.10
2	1575.42	24.3 AV	54.0	-29.7	1.00 H	169	-4.80	29.10
3	3150.84	42.0 PK	74.0	-32.0	1.00 H	218	8.70	33.30
4	3150.84	29.1 AV	54.0	-24.9	1.00 H	218	-4.20	33.30
5	4726.26	45.0 PK	74.0	-29.0	1.00 H	315	8.00	37.00
6	4726.26	31.7 AV	54.0	-22.3	1.00 H	315	-5.30	37.00
ANTENNA POLARITY & TEST DISTANCE: VERTICAL AT 3 M								
NO.	FREQ. (MHz)	EMISSION LEVEL (dBuV/m)	LIMIT (dBuV/m)	MARGIN (dB)	ANTENNA HEIGHT (m)	TABLE ANGLE (Degree)	RAW VALUE (dBuV)	CORRECTION FACTOR (dB/m)
1	1575.42	50.8 PK	74.0	-23.2	1.00 V	165	21.70	29.10
2	1575.42	38.2 AV	54.0	-15.8	1.00 V	165	9.10	29.10
3	3150.84	42.1 PK	74.0	-31.9	1.00 V	128	8.80	33.30
4	3150.84	29.3 AV	54.0	-24.7	1.00 V	128	-4.00	33.30
5	4726.26	45.8 PK	74.0	-28.2	1.00 V	199	8.80	37.00
6	4726.26	31.8 AV	54.0	-22.2	1.00 V	199	-5.20	37.00

- REMARKS:**
1. Emission level (dBuV/m) = Raw Value (dBuV) + Correction Factor (dB/m).
 2. Correction Factor (dB/m) = Antenna Factor (dB/m) + Cable Factor (dB).
 3. The other emission levels were very low against the limit.
 4. Margin value = Emission level – Limit value.

BELOW 1GHz WORST-CASE DATA :

EUT TEST CONDITION		MEASUREMENT DETAIL	
INPUT POWER (SYSTEM)	120Vac, 60Hz	FREQUENCY RANGE	Below 1000MHz
ENVIRONMENTAL CONDITIONS	25deg. C, 65%RH	DETECTOR FUNCTION	Quasi-Peak
TESTED BY	David Huang	TEST MODE	A

ANTENNA POLARITY & TEST DISTANCE: HORIZONTAL AT 3 M								
NO.	FREQ. (MHz)	EMISSION LEVEL (dBuV/m)	LIMIT (dBuV/m)	MARGIN (dB)	ANTENNA HEIGHT (m)	TABLE ANGLE (Degree)	RAW VALUE (dBuV)	CORRECTION FACTOR (dB/m)
1	72.67	27.4 QP	40.0	-12.6	1.50 H	52	16.10	11.30
2	103.78	26.0 QP	43.5	-17.5	1.50 H	85	15.30	10.70
3	166.00	30.7 QP	43.5	-12.8	1.50 H	130	16.70	14.00
4	331.26	27.7 QP	46.0	-18.3	1.00 H	145	12.00	15.70
5	500.42	34.3 QP	46.0	-11.7	1.50 H	286	14.10	20.20
6	832.89	36.5 QP	46.0	-9.5	1.50 H	166	10.70	25.80
ANTENNA POLARITY & TEST DISTANCE: VERTICAL AT 3 M								
NO.	FREQ. (MHz)	EMISSION LEVEL (dBuV/m)	LIMIT (dBuV/m)	MARGIN (dB)	ANTENNA HEIGHT (m)	TABLE ANGLE (Degree)	RAW VALUE (dBuV)	CORRECTION FACTOR (dB/m)
1	103.78	33.0 QP	43.5	-10.5	1.00 V	274	22.30	10.70
2	166.00	32.1 QP	43.5	-11.4	1.00 V	16	18.10	14.00
3	331.26	28.4 QP	46.0	-17.6	1.50 V	145	12.70	15.70
4	496.53	38.4 QP	46.0	-7.6	1.00 V	67	18.30	20.10
5	665.68	34.6 QP	46.0	-11.4	1.00 V	139	11.10	23.50
6	832.89	40.7 QP	46.0	-5.3	1.50 V	244	14.90	25.80

- REMARKS:**
1. Emission level (dBuV/m) = Raw Value (dBuV) + Correction Factor (dB/m).
 2. Correction Factor (dB/m) = Antenna Factor (dB/m) + Cable Factor (dB).
 3. The other emission levels were very low against the limit.
 4. Margin value = Emission level – Limit value.



A D T

EUT TEST CONDITION		MEASUREMENT DETAIL	
INPUT POWER (SYSTEM)	120Vac, 60Hz	FREQUENCY RANGE	Below 1000MHz
ENVIRONMENTAL CONDITIONS	25deg. C, 65%RH	DETECTOR FUNCTION	Quasi-Peak
TESTED BY	David Huang	TEST MODE	B

ANTENNA POLARITY & TEST DISTANCE: HORIZONTAL AT 3 M								
NO.	FREQ. (MHz)	EMISSION LEVEL (dBuV/m)	LIMIT (dBuV/m)	MARGIN (dB)	ANTENNA HEIGHT (m)	TABLE ANGLE (Degree)	RAW VALUE (dBuV)	CORRECTION FACTOR (dB/m)
1	166.00	29.7 QP	43.5	-13.8	1.50 H	142	15.70	14.00
2	498.47	31.7 QP	46.0	-14.3	1.00 H	40	11.50	20.20
3	599.58	32.2 QP	46.0	-13.8	1.00 H	67	9.80	22.40
4	663.74	32.1 QP	46.0	-13.9	1.50 H	67	8.60	23.50
5	733.73	30.6 QP	46.0	-15.4	1.00 H	106	6.10	24.50
6	830.95	37.9 QP	46.0	-8.1	1.00 H	79	12.10	25.80
ANTENNA POLARITY & TEST DISTANCE: VERTICAL AT 3 M								
NO.	FREQ. (MHz)	EMISSION LEVEL (dBuV/m)	LIMIT (dBuV/m)	MARGIN (dB)	ANTENNA HEIGHT (m)	TABLE ANGLE (Degree)	RAW VALUE (dBuV)	CORRECTION FACTOR (dB/m)
1	103.78	32.7 QP	43.5	-10.8	1.00 V	280	22.00	10.70
2	166.00	31.4 QP	43.5	-12.1	1.00 V	328	17.40	14.00
3	372.09	25.0 QP	46.0	-21.0	1.50 V	112	8.30	16.70
4	496.53	37.2 QP	46.0	-8.8	1.00 V	85	17.10	20.10
5	665.68	34.7 QP	46.0	-11.3	1.00 V	166	11.20	23.50
6	830.95	40.7 QP	46.0	-5.3	1.50 V	208	14.90	25.80

- REMARKS:**
1. Emission level (dBuV/m) = Raw Value (dBuV) + Correction Factor (dB/m).
 2. Correction Factor (dB/m) = Antenna Factor (dB/m) + Cable Factor (dB).
 3. The other emission levels were very low against the limit.
 4. Margin value = Emission level – Limit value.



A D T

EUT TEST CONDITION		MEASUREMENT DETAIL	
INPUT POWER (SYSTEM)	120Vac, 60Hz	FREQUENCY RANGE	Below 1000MHz
ENVIRONMENTAL CONDITIONS	25deg. C, 65%RH	DETECTOR FUNCTION	Quasi-Peak
TESTED BY	David Huang	TEST MODE	C

ANTENNA POLARITY & TEST DISTANCE: HORIZONTAL AT 3 M								
NO.	FREQ. (MHz)	EMISSION LEVEL (dBuV/m)	LIMIT (dBuV/m)	MARGIN (dB)	ANTENNA HEIGHT (m)	TABLE ANGLE (Degree)	RAW VALUE (dBuV)	CORRECTION FACTOR (dB/m)
1	72.67	29.2 QP	40.0	-10.8	1.50 H	7	17.90	11.30
2	166.00	30.5 QP	43.5	-13.0	1.50 H	124	16.50	14.00
3	333.21	28.6 QP	46.0	-17.4	1.00 H	121	12.90	15.70
4	496.53	34.2 QP	46.0	-11.8	1.50 H	214	14.10	20.10
5	599.58	32.5 QP	46.0	-13.5	1.00 H	64	10.10	22.40
6	663.74	32.9 QP	46.0	-13.1	1.00 H	73	9.40	23.50
ANTENNA POLARITY & TEST DISTANCE: VERTICAL AT 3 M								
NO.	FREQ. (MHz)	EMISSION LEVEL (dBuV/m)	LIMIT (dBuV/m)	MARGIN (dB)	ANTENNA HEIGHT (m)	TABLE ANGLE (Degree)	RAW VALUE (dBuV)	CORRECTION FACTOR (dB/m)
1	103.78	33.6 QP	43.5	-9.9	1.00 V	271	22.90	10.70
2	166.00	31.5 QP	43.5	-12.0	1.00 V	10	17.50	14.00
3	364.32	26.4 QP	46.0	-19.6	1.50 V	91	9.90	16.50
4	500.42	38.1 QP	46.0	-7.9	1.00 V	73	17.90	20.20
5	663.74	37.2 QP	46.0	-8.8	1.00 V	172	13.70	23.50
6	832.89	41.8 QP	46.0	-4.2	1.50 V	196	16.00	25.80

- REMARKS:**
1. Emission level (dBuV/m) = Raw Value (dBuV) + Correction Factor (dB/m).
 2. Correction Factor (dB/m) = Antenna Factor (dB/m) + Cable Factor (dB).
 3. The other emission levels were very low against the limit.
 4. Margin value = Emission level – Limit value.



A D T

EUT TEST CONDITION		MEASUREMENT DETAIL	
INPUT POWER	120Vac, 60 Hz	FREQUENCY RANGE	Below 1000MHz
ENVIRONMENTAL CONDITIONS	25deg. C, 65%RH	DETECTOR FUNCTION	Quasi-Peak
TESTED BY	Aska Huang	TEST MODE	D

ANTENNA POLARITY & TEST DISTANCE: HORIZONTAL AT 3 M

NO.	FREQ. (MHz)	EMISSION LEVEL (dBuV/m)	LIMIT (dBuV/m)	MARGIN (dB)	ANTENNA HEIGHT (m)	TABLE ANGLE (Degree)	RAW VALUE (dBuV)	CORRECTION FACTOR (dB/m)
1	45.45	17.6 QP	40.0	-22.4	2.00 H	134	3.60	14.00
2	160.17	24.0 QP	43.5	-19.5	1.50 H	260	9.90	14.10
3	259.33	26.4 QP	46.0	-19.6	1.24 H	253	13.00	13.40
4	302.10	28.5 QP	46.0	-17.5	1.24 H	265	13.50	15.00
5	362.37	21.3 QP	46.0	-24.7	1.00 H	137	4.70	16.60
6	498.47	21.2 QP	46.0	-24.8	2.00 H	13	1.30	19.90

ANTENNA POLARITY & TEST DISTANCE: VERTICAL AT 3 M

NO.	FREQ. (MHz)	EMISSION LEVEL (dBuV/m)	LIMIT (dBuV/m)	MARGIN (dB)	ANTENNA HEIGHT (m)	TABLE ANGLE (Degree)	RAW VALUE (dBuV)	CORRECTION FACTOR (dB/m)
1	30.00	23.8 QP	40.0	-16.2	1.50 V	286	12.00	11.80
2	53.23	21.9 QP	40.0	-18.1	1.50 V	229	8.10	13.80
3	82.40	22.7 QP	40.0	-17.3	1.00 V	19	13.20	9.50
4	226.27	19.7 QP	46.0	-26.3	2.00 V	9	7.60	12.10
5	305.99	26.2 QP	46.0	-19.8	1.24 V	175	11.10	15.10
6	473.20	22.1 QP	46.0	-23.9	1.00 V	153	2.80	19.30

- REMARKS:**
1. Emission level (dBuV/m) = Raw Value (dBuV) + Correction Factor (dB/m).
 2. Correction Factor (dB/m) = Antenna Factor (dB/m) + Cable Factor (dB).
 3. The other emission levels were very low against the limit.
 4. Margin value = Emission level – Limit value.

4.2 CONDUCTED EMISSION MEASUREMENT

4.2.1 LIMITS OF CONDUCTED EMISSION MEASUREMENT

FREQUENCY OF EMISSION (MHz)	CONDUCTED LIMIT (dB μ V)	
	Quasi-peak	Average
0.15-0.5	66 to 56	56 to 46
0.5-5	56	46
5-30	60	50

- NOTE:**
1. The lower limit shall apply at the transition frequencies.
 2. The limit decreases in line with the logarithm of the frequency in the range of 0.15 to 0.50 MHz.
 3. All emanations from a class A/B digital device or system, including any network of conductors and apparatus connected thereto, shall not exceed the level of field strengths specified above.



4.2.2 TEST INSTRUMENTS

FOR TEST MODE A, B, C

DESCRIPTION & MANUFACTURER	MODEL NO.	SERIAL NO.	DATE OF CALIBRATION	DUE DATE OF CALIBRATION
Test Receiver ROHDE & SCHWARZ	ESCS30	100291	Nov. 30, 2010	Nov. 29, 2011
RF signal cable Woken	5D-FB	Cable-HYC01-01	Dec. 30, 2010	Dec. 29, 2011
LISN ROHDE & SCHWARZ	ESH3-Z5	100312	Jul. 07, 2011	Jul. 06, 2012
LISN ROHDE & SCHWARZ	ESH2-Z5	100100	Jan. 06, 2011	Jan. 05, 2012
LISN ROHDE & SCHWARZ	ESH3-Z5	835239/001	Feb. 22, 2011	Feb. 21, 2012
V-LISN SCHWARZBECK	NNBL 8226-2	8226-142	Jun. 30, 2011	Jun. 29, 2012
LISN ROHDE & SCHWARZ	ENV216	100072	Jun. 10, 2011	Jun. 09, 2012
Software ADT	ADT_Cond_ V7.3.7	NA	NA	NA

- NOTE:** 1. The calibration interval of the above test instruments is 12 months and the calibrations are traceable to NML/ROC and NIST/USA.
2. The test was performed in HwaYa Shielded Room 1.
3. The VCCI Site Registration No. is C-2040.

FOR TEST MODE D

DESCRIPTION & MANUFACTURER	MODEL NO.	SERIAL NO.	DATE OF CALIBRATION	DUE DATE OF CALIBRATION
Test Receiver ROHDE & SCHWARZ	ESCS30	100289	Nov. 19, 2011	Nov. 18, 2012
RF signal cable Woken	5D-FB	Cable-HYCO2-01	Dec. 22, 2011	Dec. 21, 2012
LISN ROHDE & SCHWARZ	ESH2-Z5	100100	Dec. 30, 2011	Dec. 29, 2012
LISN ROHDE & SCHWARZ	ESH3-Z5	100312	Jul. 07, 2011	Jul. 06, 2012
V-LISN SCHWARZBECK	NNBL 8226-2	8226-142	Jun. 30, 2011	Jun. 29, 2012
LISN ROHDE & SCHWARZ	ENV216	100072	Jun. 10, 2011	Jun. 09, 2012
Software ADT	ADT_Cond_ V7.3.7	NA	NA	NA

- NOTE:** 1. The calibration interval of the above test instruments is 12 months and the calibrations are traceable to NML/ROC and NIST/USA.
2. The test was performed in HwaYa Shielded Room 2.
3. The VCCI Site Registration No. is C-2047.

4.2.3 TEST PROCEDURES

- The EUT was placed 0.4 meters from the conducting wall of the shielded room with EUT being connected to the power mains through a line impedance stabilization network (LISN). Other support units were connected to the power mains through another LISN. The two LISNs provide 50 ohm/ 50uH of coupling impedance for the measuring instrument.
- Both lines of the power mains connected to the EUT were checked for maximum conducted interference.
- The frequency range from 150kHz to 30MHz was searched. Emission levels under (Limit - 20dB) was not recorded.

NOTE: All modes of operation were investigated and the worst-case emissions are reported.

4.2.4 DEVIATION FROM TEST STANDARD

No deviation.

4.2.5 TEST SETUP

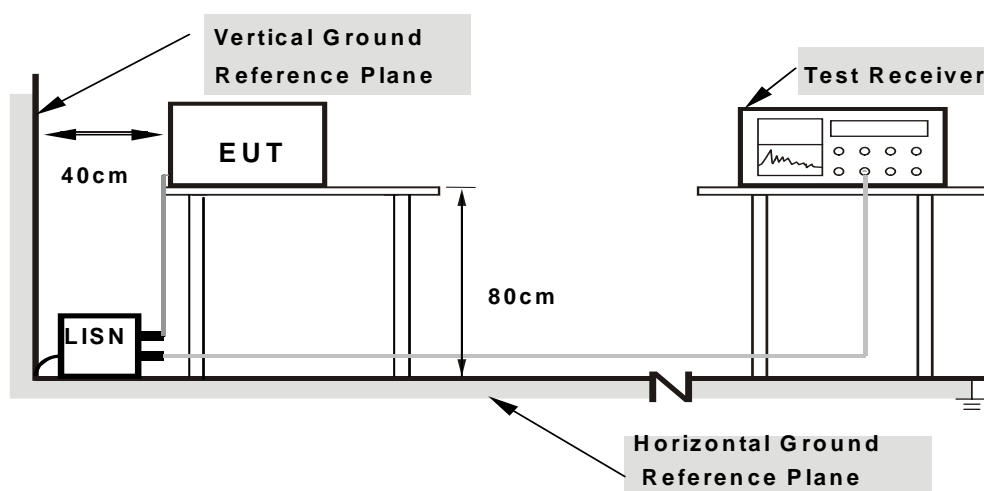

- Note:**
- Support units were connected to second LISN.
 - Both of LISNs (AMN) are 80 cm from EUT and at least 80 cm from other units and other metal planes

For the actual test configuration, please refer to the attached file (Test Setup Photo).

4.2.6 EUT OPERATING CONDITIONS

Same as item 4.1.6.

4.2.7 TEST RESULTS

CONDUCTED WORST-CASE DATA:

PHASE	Line 1	6dB BANDWIDTH	9kHz
TEST MODE	A		

No	Freq. [MHz]	Corr.	Reading Value		Emission Level		Limit		Margin	
		Factor	[dB (uV)]		[dB (uV)]		[dB (uV)]		(dB)	
		(dB)	Q.P.	AV.	Q.P.	AV.	Q.P.	AV.	Q.P.	AV.
1	0.412	0.25	33.52	-	33.77	-	57.61	47.61	-23.84	-
2	0.548	0.24	35.35	-	35.59	-	56.00	46.00	-20.41	-
3	2.051	0.24	32.09	-	32.33	-	56.00	46.00	-23.67	-
4	3.215	0.33	32.88	-	33.21	-	56.00	46.00	-22.79	-
5	7.449	0.57	31.78	-	32.35	-	60.00	50.00	-27.65	-
6	15.789	0.99	31.20	-	32.19	-	60.00	50.00	-27.81	-

- REMARKS:**
1. Q.P. and AV. are abbreviations of quasi-peak and average individually.
 2. "-": The Quasi-peak reading value also meets average limit and measurement with the average detector is unnecessary.
 3. The emission levels of other frequencies were very low against the limit.
 4. Margin value = Emission level - Limit value
 5. Correction factor = Insertion loss + Cable loss
 6. Emission Level = Correction Factor + Reading Value.

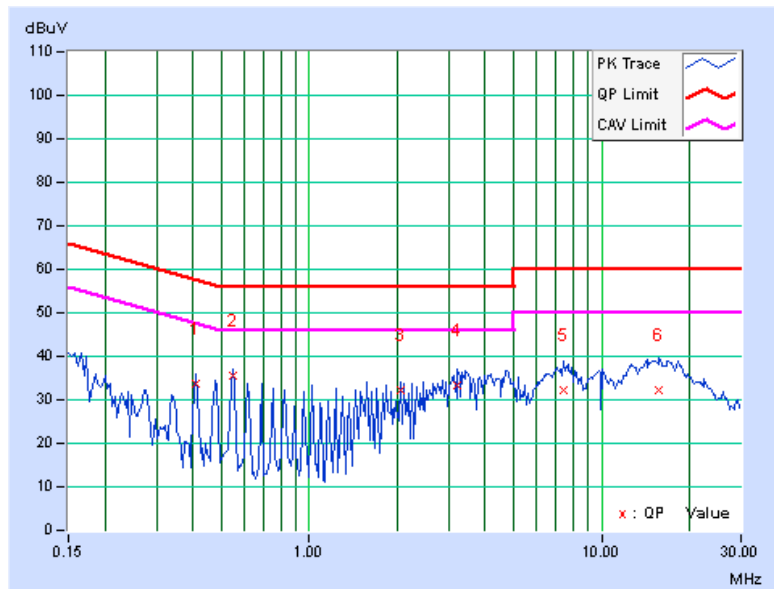

PHASE	Line 2	6dB BANDWIDTH	9kHz
TEST MODE	A		

No	Freq. [MHz]	Corr. Factor (dB)	Reading Value		Emission Level		Limit		Margin	
			[dB (uV)]		[dB (uV)]		[dB (uV)]		(dB)	
			Q.P.	AV.	Q.P.	AV.	Q.P.	AV.	Q.P.	AV.
1	0.205	0.21	37.92	-	38.13	-	63.42	53.42	-25.29	-
2	0.412	0.23	37.09	-	37.32	-	57.61	47.61	-20.29	-
3	0.548	0.24	36.85	-	37.09	-	56.00	46.00	-18.91	-
4	1.991	0.30	30.03	-	30.33	-	56.00	46.00	-25.67	-
5	3.078	0.37	30.26	-	30.63	-	56.00	46.00	-25.37	-
6	15.191	0.85	28.69	-	29.54	-	60.00	50.00	-30.46	-

- REMARKS:**
1. Q.P. and AV. are abbreviations of quasi-peak and average individually.
 2. "-": The Quasi-peak reading value also meets average limit and measurement with the average detector is unnecessary.
 3. The emission levels of other frequencies were very low against the limit.
 4. Margin value = Emission level - Limit value
 5. Correction factor = Insertion loss + Cable loss
 6. Emission Level = Correction Factor + Reading Value.

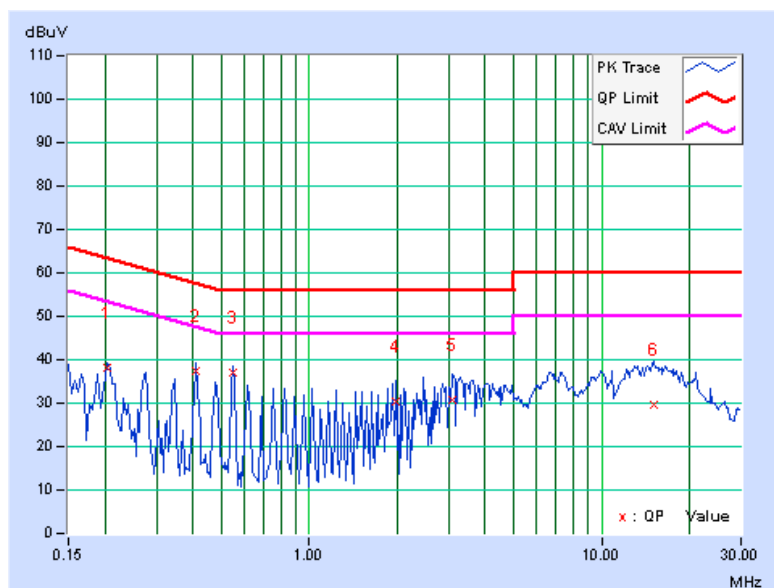



A D T

PHASE	Line 1	6dB BANDWIDTH	9kHz
TEST MODE	B		

No	Freq. [MHz]	Corr. Factor (dB)	Reading Value		Emission Level		Limit		Margin	
			[dB (uV)]		[dB (uV)]		[dB (uV)]		(dB)	
			Q.P.	AV.	Q.P.	AV.	Q.P.	AV.	Q.P.	AV.
1	0.166	0.16	23.62	-	23.78	-	65.18	55.18	-41.40	-
2	0.274	0.18	28.21	-	28.39	-	60.98	50.98	-32.59	-
3	2.113	0.25	29.96	-	30.21	-	56.00	46.00	-25.79	-
4	3.273	0.34	32.86	-	33.20	-	56.00	46.00	-22.80	-
5	7.363	0.57	25.84	-	26.41	-	60.00	50.00	-33.59	-
6	15.141	0.96	30.43	-	31.39	-	60.00	50.00	-28.61	-

- REMARKS:**
1. Q.P. and AV. are abbreviations of quasi-peak and average individually.
 2. "-": The Quasi-peak reading value also meets average limit and measurement with the average detector is unnecessary.
 3. The emission levels of other frequencies were very low against the limit.
 4. Margin value = Emission level - Limit value
 5. Correction factor = Insertion loss + Cable loss
 6. Emission Level = Correction Factor + Reading Value.

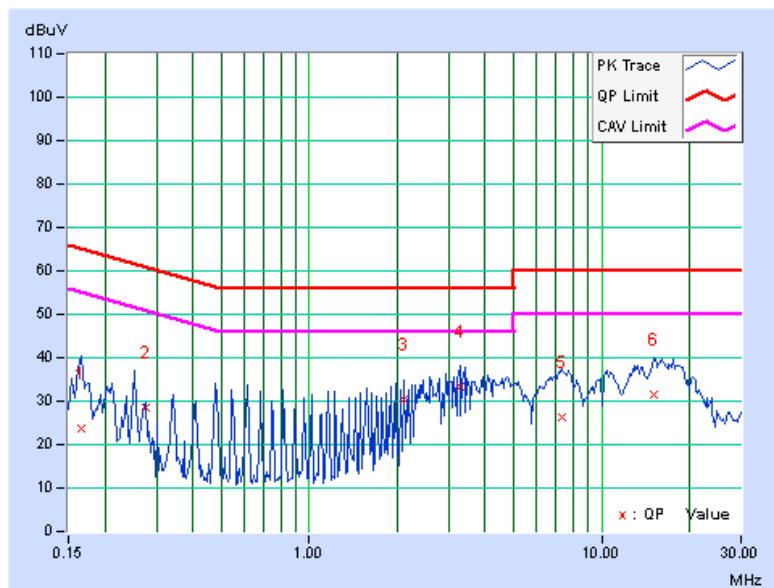



A D T

PHASE	Line 2	6dB BANDWIDTH	9kHz
TEST MODE	B		

No	Freq. [MHz]	Corr. Factor (dB)	Reading Value		Emission Level		Limit		Margin	
			[dB (uV)]		[dB (uV)]		[dB (uV)]		(dB)	
			Q.P.	AV.	Q.P.	AV.	Q.P.	AV.	Q.P.	AV.
1	0.205	0.21	37.00	-	37.21	-	63.42	53.42	-26.21	-
2	0.341	0.22	34.18	-	34.40	-	59.17	49.17	-24.76	-
3	0.478	0.24	34.56	-	34.80	-	56.37	46.37	-21.58	-
4	3.340	0.39	36.33	-	36.72	-	56.00	46.00	-19.28	-
5	13.359	0.79	34.84	-	35.63	-	60.00	50.00	-24.37	-
6	17.848	0.95	32.95	-	33.90	-	60.00	50.00	-26.10	-

- REMARKS:**
1. Q.P. and AV. are abbreviations of quasi-peak and average individually.
 2. "-": The Quasi-peak reading value also meets average limit and measurement with the average detector is unnecessary.
 3. The emission levels of other frequencies were very low against the limit.
 4. Margin value = Emission level - Limit value
 5. Correction factor = Insertion loss + Cable loss
 6. Emission Level = Correction Factor + Reading Value.

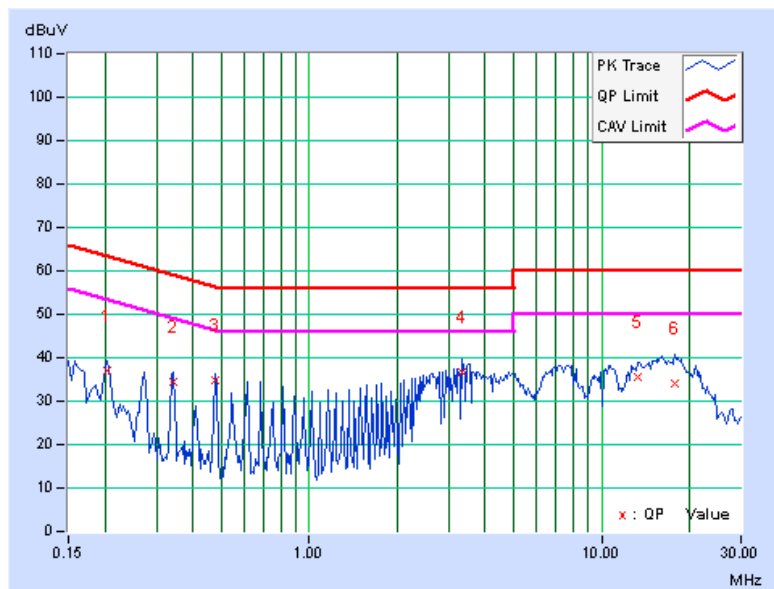



A D T

PHASE	Line 1	6dB BANDWIDTH	9kHz
TEST MODE	C		

No	Freq. [MHz]	Corr.	Reading Value		Emission Level		Limit		Margin	
		Factor	[dB (uV)]		[dB (uV)]		[dB (uV)]		(dB)	
		(dB)	Q.P.	AV.	Q.P.	AV.	Q.P.	AV.	Q.P.	AV.
1	0.482	0.24	32.65	-	32.89	-	56.30	46.30	-23.41	-
2	1.785	0.23	33.02	-	33.25	-	56.00	46.00	-22.75	-
3	2.336	0.27	35.58	-	35.85	-	56.00	46.00	-20.15	-
4	3.504	0.35	34.91	-	35.26	-	56.00	46.00	-20.74	-
5	4.879	0.44	34.20	-	34.64	-	56.00	46.00	-21.36	-
6	15.105	0.96	32.13	-	33.09	-	60.00	50.00	-26.91	-

- REMARKS:**
1. Q.P. and AV. are abbreviations of quasi-peak and average individually.
 2. "-": The Quasi-peak reading value also meets average limit and measurement with the average detector is unnecessary.
 3. The emission levels of other frequencies were very low against the limit.
 4. Margin value = Emission level - Limit value
 5. Correction factor = Insertion loss + Cable loss
 6. Emission Level = Correction Factor + Reading Value.

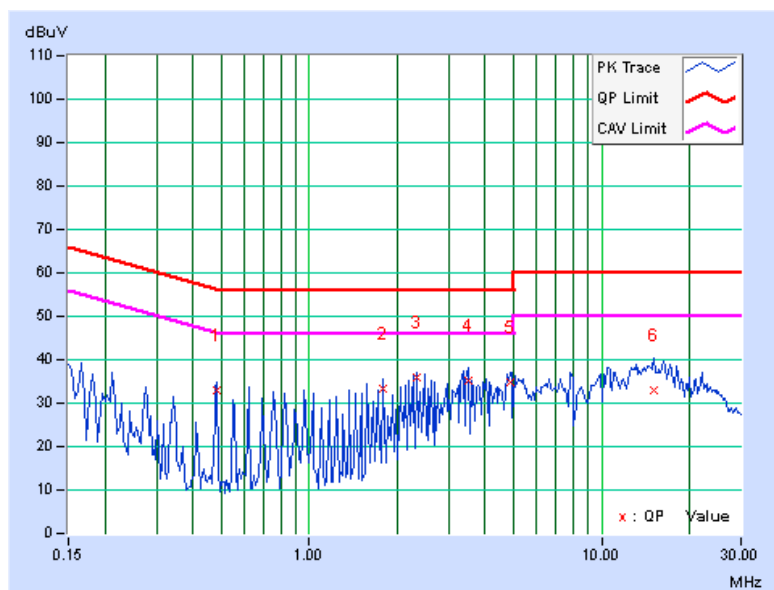



A D T

PHASE	Line 2	6dB BANDWIDTH	9kHz
TEST MODE	C		

No	Freq. [MHz]	Corr. Factor (dB)	Reading Value		Emission Level		Limit		Margin	
			[dB (uV)]		[dB (uV)]		[dB (uV)]		(dB)	
			Q.P.	AV.	Q.P.	AV.	Q.P.	AV.	Q.P.	AV.
1	0.205	0.21	38.54	-	38.75	-	63.42	53.42	-24.67	-
2	0.408	0.23	33.14	-	33.37	-	57.69	47.69	-24.32	-
3	0.548	0.24	35.13	-	35.37	-	56.00	46.00	-20.63	-
4	3.355	0.39	25.41	-	25.80	-	56.00	46.00	-30.20	-
5	13.871	0.81	35.99	-	36.80	-	60.00	50.00	-23.20	-
6	17.848	0.95	34.23	-	35.18	-	60.00	50.00	-24.82	-

- REMARKS:**
1. Q.P. and AV. are abbreviations of quasi-peak and average individually.
 2. "-": The Quasi-peak reading value also meets average limit and measurement with the average detector is unnecessary.
 3. The emission levels of other frequencies were very low against the limit.
 4. Margin value = Emission level - Limit value
 5. Correction factor = Insertion loss + Cable loss
 6. Emission Level = Correction Factor + Reading Value.

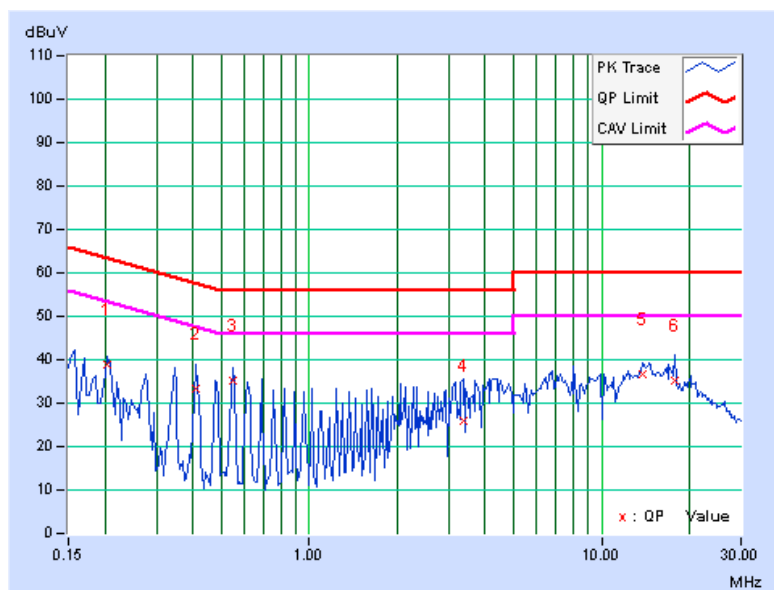



A D T

PHASE	Line 1	6dB BANDWIDTH	9kHz
TEST MODE	D		

No	Freq. [MHz]	Corr. Factor (dB)	Reading Value		Emission Level		Limit		Margin	
			[dB (uV)]		[dB (uV)]		[dB (uV)]		(dB)	
			Q.P.	AV.	Q.P.	AV.	Q.P.	AV.	Q.P.	AV.
1	0.15000	0.15	46.11	-	46.26	-	66.00	56.00	-19.74	-
2	0.22422	0.15	38.41	-	38.56	-	62.66	52.66	-24.10	-
3	0.67344	0.18	37.85	-	38.03	-	56.00	46.00	-17.97	-
4	3.32813	0.31	41.96	-	42.27	-	56.00	46.00	-13.73	-
5	3.83203	0.33	39.91	-	40.24	-	56.00	46.00	-15.76	-
6	23.54688	0.59	38.94	-	39.53	-	60.00	50.00	-20.47	-

- REMARKS:**
1. Q.P. and AV. are abbreviations of quasi-peak and average individually.
 2. "-": The Quasi-peak reading value also meets average limit and measurement with the average detector is unnecessary.
 3. The emission levels of other frequencies were very low against the limit.
 4. Margin value = Emission level - Limit value
 5. Correction factor = Insertion loss + Cable loss
 6. Emission Level = Correction Factor + Reading Value.

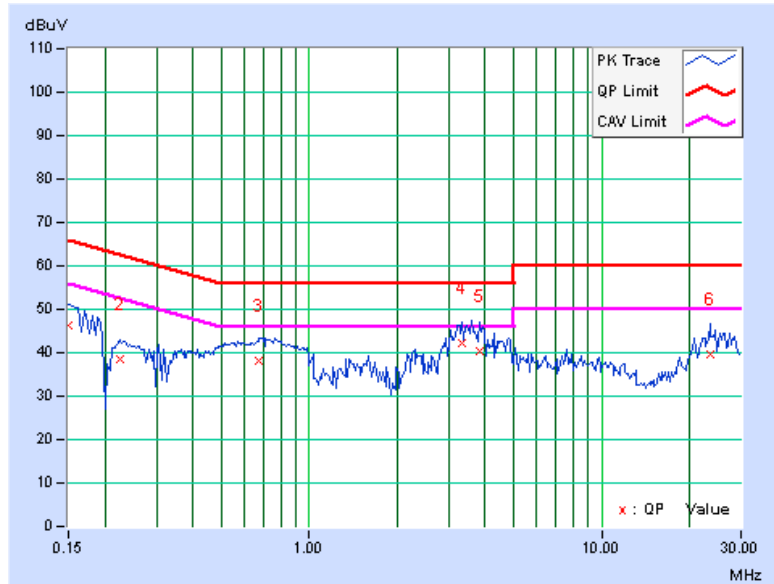

PHASE	Line 2	6dB BANDWIDTH	9kHz
TEST MODE	D		

No	Freq. [MHz]	Corr. Factor (dB)	Reading Value		Emission Level		Limit		Margin	
			[dB (uV)]		[dB (uV)]		[dB (uV)]		(dB)	
			Q.P.	AV.	Q.P.	AV.	Q.P.	AV.	Q.P.	AV.
1	0.15000	0.13	47.06	-	47.19	-	66.00	56.00	-18.81	-
2	0.21641	0.14	38.09	-	38.23	-	62.96	52.96	-24.72	-
3	0.36484	0.16	36.87	-	37.03	-	58.62	48.62	-21.59	-
4	3.38281	0.32	37.81	-	38.13	-	56.00	46.00	-17.87	-
5	3.68359	0.34	37.86	-	38.20	-	56.00	46.00	-17.80	-
6	4.83203	0.37	31.05	-	31.42	-	56.00	46.00	-24.58	-

- REMARKS:**
1. Q.P. and AV. are abbreviations of quasi-peak and average individually.
 2. "-": The Quasi-peak reading value also meets average limit and measurement with the average detector is unnecessary.
 3. The emission levels of other frequencies were very low against the limit.
 4. Margin value = Emission level - Limit value
 5. Correction factor = Insertion loss + Cable loss
 6. Emission Level = Correction Factor + Reading Value.

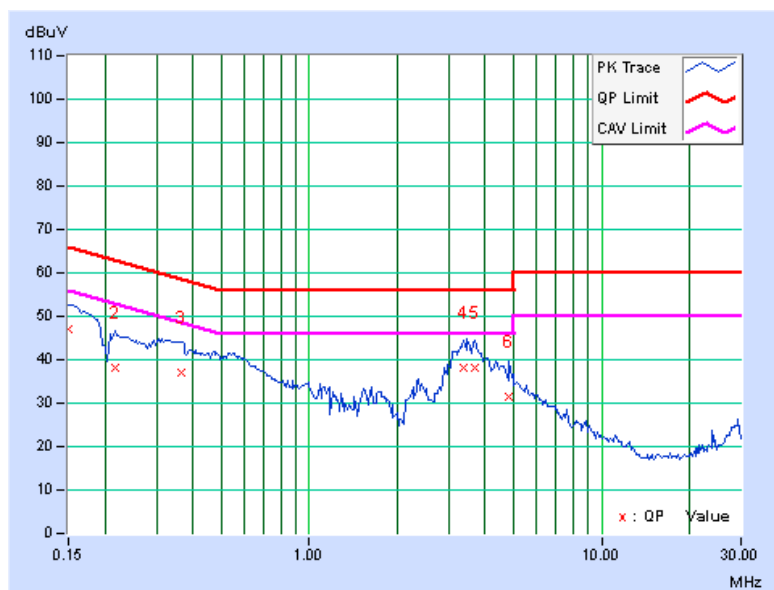



5. PHOTOGRAPHS OF THE TEST CONFIGURATION

Please refer to the attached file (Test Setup Photo).



6. INFORMATION ON THE TESTING LABORATORIES

We, Bureau Veritas Consumer Products Services (H.K.) Ltd., Taoyuan Branch, were founded in 1988 to provide our best service in EMC, Radio, Telecom and Safety consultation. Our laboratories are accredited and approved according to ISO/IEC 17025.

Copies of accreditation and authorization certificates of our laboratories obtained from approval agencies can be downloaded from our web site: www.adt.com.tw/index.5.phtml. If you have any comments, please feel free to contact us at the following:

Linko EMC/RF Lab:

Tel: 886-2-26052180

Fax: 886-2-26051924

Hsin Chu EMC/RF Lab:

Tel: 886-3-5935343

Fax: 886-3-5935342

Hwa Ya EMC/RF/Safety Telecom Lab:

Tel: 886-3-3183232

Fax: 886-3-3185050

Email: service.adt@tw.bureauveritas.com

Web Site: www.adt.com.tw

The address and road map of all our labs can be found in our web site also.

7. APPENDIX A - MODIFICATIONS RECORDERS FOR ENGINEERING CHANGES TO THE EUT BY THE LAB

No any modifications are made to the EUT by the lab during the test.

--- END ---