



# FCC CERTIFICATION TEST REPORT

**REPORT NO.:** FD991223C13  
**MODEL NO.:** F-09C  
**RECEIVED:** Dec. 23, 2010  
**TESTED:** Feb. 15 ~ Feb. 17, 2011  
**ISSUED:** Feb. 23, 2011

**APPLICANT:** FUJITSU LIMITED

**ADDRESS:** 1-1, Kamikodanaka 4-chome, Nakahara-ku,  
Kawasaki 211-8588, Japan

**ISSUED BY:** Bureau Veritas Consumer Products Services (H.K.)  
Ltd., Taoyuan Branch

**LAB ADDRESS:** No. 47, 14th Ling, Chia Pau Tsuen, Lin Kou Hsiang,  
Taipei Hsien 244, Taiwan, R.O.C.

**TEST LOCATION:** No. 19, Hwa Ya 2nd Rd, Wen Hwa Tsuen, Kwei  
Shan Hsiang, Taoyuan Hsien 333, Taiwan, R.O.C.

This test report consists of 35 pages in total. It may be duplicated completely for legal use with the approval of the applicant. It should not be reproduced except in full, without the written approval of our laboratory. The client should not use it to claim product, certification, approval or endorsement by TAF or any government agency. The test results in the report only apply to the tested sample. The test results in this report are traceable to the national or international standards.





# Table of Contents

RELEASE CONTROL RECORD.....	3
1. CERTIFICATION.....	4
2. SUMMARY OF TEST RESULTS .....	5
2.1 MEASUREMENT UNCERTAINTY .....	5
3. GENERAL INFORMATION.....	6
3.1 GENERAL DESCRIPTION OF EUT.....	6
3.2 DESCRIPTION OF TEST MODES.....	8
3.3 DESCRIPTION OF SUPPORT UNITS .....	8
3.3.1 CONFIGURATION OF SYSTEM UNDER TEST .....	9
3.4 GENERAL DESCRIPTION OF APPLIED STANDARDS .....	10
4. TEST TYPES AND RESULTS .....	11
4.1 RADIATED EMISSION MEASUREMENT .....	11
4.1.1 LIMITS OF RADIATED EMISSION MEASUREMENT.....	11
4.1.2 TEST INSTRUMENTS .....	12
4.1.3 TEST PROCEDURES .....	13
4.1.4 DEVIATION FROM TEST STANDARD .....	13
4.1.5 TEST SETUP .....	14
4.1.6 EUT OPERATING CONDITIONS.....	14
4.1.7 TEST RESULTS .....	15
4.2 CONDUCTED EMISSION MEASUREMENT .....	24
4.2.1 LIMITS OF CONDUCTED EMISSION MEASUREMENT.....	24
4.2.2 TEST INSTRUMENTS .....	24
4.2.3 TEST PROCEDURES .....	25
4.2.4 DEVIATION FROM TEST STANDARD .....	25
4.2.5 TEST SETUP .....	26
4.2.6 EUT OPERATING CONDITIONS.....	26
4.2.7 TEST RESULTS .....	27
5. PHOTOGRAPHS OF THE TEST CONFIGURATION.....	33
6. INFORMATION ON THE TESTING LABORATORIES .....	34
7. APPENDIX A - MODIFICATIONS RECORDERS FOR ENGINEERING CHANGES TO THE EUT BY THE LAB.....	35



A D T

## RELEASE CONTROL RECORD

ISSUE NO.	REASON FOR CHANGE	DATE ISSUED
Original release	N/A	Feb. 23, 2011



# 1. CERTIFICATION

**PRODUCT:** Mobile phone  
**BRAND:** FOMA  
**MODEL:** F-09C  
**APPLICANT:** FUJITSU LIMITED  
**TESTED:** Feb. 15 ~ Feb. 17, 2011  
**TEST SAMPLE:** ENGINEERING SAMPLE  
**STANDARDS:** **FCC Part 15, Subpart B, Class B**  
ANSI C63.4-2003

The above equipment (Model: F-09C) has been tested by **Bureau Veritas Consumer Products Services (H.K.) Ltd., Taoyuan Branch**, and found compliance with the requirement of the above standards. The test record, data evaluation & Equipment Under Test (EUT) configurations represented herein are true and accurate accounts of the measurements of the sample's EMC characteristics under the conditions specified in this report.

PREPARED BY :  , DATE: Feb. 23, 2011  
Pettie Chen / Specialist

APPROVED BY :  , DATE: Feb. 23, 2011  
Gary Chang / Assistant Manager

## 2. SUMMARY OF TEST RESULTS

The EUT has been tested according to the following specifications:

Standard Section	Test Type	Result	Remark
FCC Part 15, Subpart B, Class B	Conducted Emission	PASS	Meet the requirement of limit. Minimum passing margin is -7.14dB at 7.406MHz.
	Radiated Emission	PASS	Meet the requirement of limit. Minimum passing margin is -1.0dB at 74.27 & 74.29MHz.

### 2.1 MEASUREMENT UNCERTAINTY

Where relevant, the following measurement uncertainty levels have been estimated for tests performed on the EUT as specified in CISPR 16-4-2:

MEASUREMENT	FREQUENCY	UNCERTAINTY
Conducted emissions	150kHz ~ 30MHz	2.44 dB
Radiated emissions	30MHz ~ 200MHz	3.19 dB
	200MHz ~1000MHz	3.21 dB

This uncertainty represents an expanded uncertainty expressed at approximately the 95% confidence level using a coverage factor of k=2.



### 3. GENERAL INFORMATION

#### 3.1 GENERAL DESCRIPTION OF EUT

<b>EUT</b>	Mobile phone			
<b>MODEL NO.</b>	F-09C			
<b>POWER SUPPLY</b>	3.7Vdc (Li-ion battery) 5.4Vdc (Adapter)			
<b>MODULATION TYPE</b>	<b>Bluetooth</b>	GFSK, $\pi$ 4-DQPSK, 8DPSK		
	<b>WLAN</b>	CCK, DQPSK, DBPSK for DSSS 64QAM, 16QAM, QPSK, BPSK for OFDM		
	<b>RFID</b>	ASK		
	<b>WCDMA 850</b>	WCDMA (Band 5) / HSDPA / HSUPA		
	<b>PCS 1900</b>	GMSK		
<b>FREQUENCY RANGE</b>	<b>Bluetooth</b>	2402 ~ 2480MHz		
	<b>WLAN</b>	2412 ~ 2462MHz		
	<b>RFID</b>	13.56MHz		
	<b>WCDMA 850</b>	826.4MHz ~ 846.6MHz		
	<b>PCS 1900</b>	1850.2MHz ~ 1909.8MHz		
<b>NUMBER OF CHANNEL</b>	<b>Bluetooth</b>	79		
	<b>WLAN</b>	11		
	<b>RFID</b>	1		
	<b>WCDMA 850</b>	102		
	<b>PCS 1900</b>	299		
<b>ANTENNA TYPE</b>	<b>Bluetooth</b>	$\lambda/4$ monopole antenna with -3.0dBi		
	<b>WLAN</b>	$\lambda/4$ monopole antenna with -3.0dBi		
	<b>RFID</b>	Loop antenna		
		<b>Antenna Type</b>	<b>Antenna Gain</b>	
			<b>EUT Open</b>	<b>EUT Close</b>
	<b>WCDMA 850</b>	Integral antenna	-3.97487 dBi	-2.53361 dBi
	<b>PCS 1900</b>	Integral antenna	-2.80824 dBi	-2.55173 dBi
<b>DATA CABLE</b>	NA			
<b>I/O PORTS</b>	Refer to user's manual			
<b>ACCESSORY DEVICES</b>	Battery			



A D T

**NOTE:**

1. The EUT uses the following Li-ion battery:

<b>BRAND</b>	Fujitsu Limited
<b>MODEL</b>	F18
<b>RATING</b>	3.7Vdc, 960mAh

2. The following accessories are for support units only.

<b>PRODUCT</b>	<b>BRAND</b>	<b>DESCRIPTION</b>
Adapter	SMK	I/P: 100-240Vac, 50-60Hz, 0.12A O/P: 5.4Vdc, 700mA
USB cable	NA	0.8m non-shielded cable without core
HDMI cable	NA	Sticker: No. 001 Manufacture: Molex Model name: 68786-0001 1.5m shielded cable without core
		Sticker: No.003 Manufacture: OLYMPUS Model name: CB-HD1 0.8m shielded cable without core

3. IMEI Code: 355115040006840.
4. The above EUT information is declared by manufacturer and for more detailed features description, please refer to the manufacturer's specifications or User's Manual.



### 3.2 DESCRIPTION OF TEST MODES

Test modes are presented in the report as below.

TEST MODE	DESCRIPTION		TEST ITEM
A	USB mode	X Axis	All test items
B		Y Axis	Radiated emission test only
C		Z Axis	Radiated emission test only
D	HDMI mode (Manufacture: Molex)	X Axis	All test items
E		Y Axis	Radiated emission test only
F		Z Axis	Radiated emission test only
G	HDMI mode (Manufacture: OLYMPUS)	X Axis	All test items
H		Y Axis	Radiated emission test only
I		Z Axis	Radiated emission test only

### 3.3 DESCRIPTION OF SUPPORT UNITS

The EUT has been tested as an independent unit together with other necessary accessories or support units. The following support units or accessories were used to form a representative test configuration during the tests.

NO.	PRODUCT	BRAND	MODEL NO.	SERIAL NO.	FCC ID
1	NOTEBOOK	HP	n6000	CNU3480WP2	NA
2	MODEM	ACEEX	1414V/3	0401008270	IFAXDM1414
3	PRINTER	EPSON	LQ-300+	DCGY054146	FCC DoC Approved
4	LCD TV	SANYO	SMT-32HD3	1617323K	NA

NO.	SIGNAL CABLE DESCRIPTION OF THE ABOVE SUPPORT UNITS
1	0.8m USB cable. (For test mode A, B, C)
2	1.2m braid shielded wire, DB25 & DB9 connector, w/o core.
3	1.8m braid shielded wire, DB25 connector, w/o core.
4	1.5m HDMI shielded cable without core (For test mode D, E, F) 0.8m HDMI shielded cable without core (For test mode G, H, I)

**NOTE:**

- 1. All power cords of the above support units are non shielded (1.8m).
- 2. The USB cable & HDMI cable were supplied from the client.



### 3.3.1 CONFIGURATION OF SYSTEM UNDER TEST

#### Test Mode A, B, C

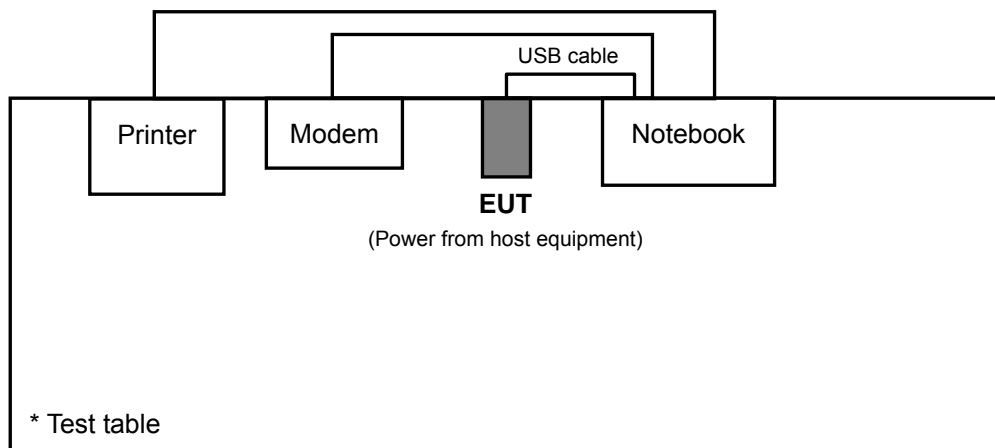

#### Test Mode D ~ I

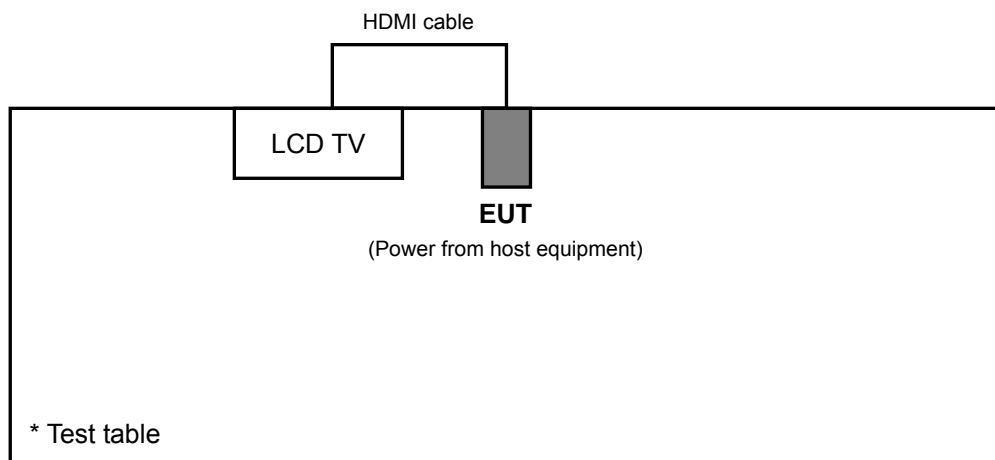

### **3.4 GENERAL DESCRIPTION OF APPLIED STANDARDS**

The EUT is a RF Product. According to the specifications of the manufacturer, it must comply with the requirements of the following standards:

**FCC Part 15, Subpart B, Class B**  
**ANSI C63.4-2003**

All test items have been performed and recorded as per the above standards.

## 4. TEST TYPES AND RESULTS

### 4.1 RADIATED EMISSION MEASUREMENT

#### 4.1.1 LIMITS OF RADIATED EMISSION MEASUREMENT

Emissions radiated outside of the specified bands, shall be according to the general radiated limits in 15.109 as following:

FREQUENCIES (MHz)	FIELD STRENGTH (microvolts/meter)	MEASUREMENT DISTANCE (meters)
30 ~ 88	100	3
88 ~ 216	150	3
216 ~ 960	200	3
Above 960	500	3

**NOTE:**

1. The lower limit shall apply at the transition frequencies.
2. Emission level (dBuV/m) = 20 log Emission level (uV/m).
3. As shown in 15.35(b), for frequencies above 1000MHz, the field strength limits are based on average detector, however, the peak field strength of any emission shall not exceed the maximum permitted average limits, specified above by more than 20dB under any condition of modulation.

#### 4.1.2 TEST INSTRUMENTS

DESCRIPTION & MANUFACTURER	MODEL NO.	SERIAL NO.	DATE OF CALIBRATION	DUE DATE OF CALIBRATION
Test Receiver ROHDE & SCHWARZ	ESI7	838496/016	Dec. 27, 2010	Dec. 26, 2011
Spectrum Analyzer ROHDE & SCHWARZ	FSU43	100115	Aug. 02, 2010	Aug. 01, 2011
BILOG Antenna SCHWARZBECK	VULB9168	9168-155	Apr. 28, 2010	Apr. 27, 2011
HORN Antenna SCHWARZBECK	BBHA 9120D	9120D-408	Jan. 06, 2011	Jan. 05, 2012
HORN Antenna SCHWARZBECK	BBHA 9170	BBHA9170243	Dec. 27, 2010	Dec. 26, 2011
Preamplifier Agilent	8449B	3008A01961	Nov. 02, 2010	Nov. 01, 2011
Preamplifier Agilent	8447D	2944A10738	Nov. 02, 2010	Nov. 01, 2011
RF signal cable HUBER+SUHNNER	SUCOFLEX 104	274041/4	Aug. 21, 2010	Aug. 20, 2011
RF signal cable HUBER+SUHNNER	SUCOFLEX 104	283397/4	Aug. 21, 2010	Aug. 20, 2011
Software ADT.	ADT_Radiated_ V7.6.15.9.2	NA	NA	NA
Antenna Tower inn-co GmbH	MA 4000	010303	NA	NA
Antenna Tower Controller inn-co GmbH	CO2000	019303	NA	NA
Turn Table ADT.	TT100.	TT93021704	NA	NA
Turn Table Controller ADT.	SC100.	SC93021704	NA	NA

- NOTE:**
1. The calibration interval of the above test instruments is 12 months and the calibrations are traceable to NML/ROC and NIST/USA.
  2. The test was performed in HwaYa Chamber 4.
  3. The horn antenna and HP preamplifier (model: 8449B) are used only for the measurement of emission frequency above 1GHz if tested.
  4. The FCC Site Registration No. is 988962.
  5. The IC Site Registration No. is IC7450F-4.

#### 4.1.3 TEST PROCEDURES

- a. The EUT was placed on the top of a rotating table 0.8 meters above the ground at a 3 meter semi-anechoic chamber. The table was rotated 360 degrees to determine the position of the highest radiation.
- b. The EUT was set 3 meters away from the interference-receiving antenna, which was mounted on the top of a variable-height antenna tower.
- c. The antenna is a broadband antenna, and its height is varied from one meter to four meters above the ground to determine the maximum value of the field strength. Both horizontal and vertical polarizations of the antenna are set to make the measurement.
- d. For each suspected emission, the EUT was arranged to its worst case and then the antenna was tuned to heights from 1 meter to 4 meters and the rotatable table was turned from 0 degrees to 360 degrees to find the maximum reading.
- e. The test-receiver system was set to Peak Detect Function and Specified Bandwidth with Maximum Hold Mode.
- f. If the emission level of the EUT in peak mode was lower than the limit specified, then testing could be stopped and the peak values of the EUT would be reported. Otherwise the emissions would be re-tested one by one using peak, quasi-peak or average method as specified and then reported in a data sheet.

**NOTE:**

1. The resolution bandwidth and video bandwidth of test receiver/spectrum analyzer is 120kHz for Quasi-peak detection at frequency below 1GHz.
2. The resolution bandwidth of test receiver/spectrum analyzer is 1 MHz and video bandwidth is 3MHz for Peak detection at frequency above 1GHz.
3. All modes of operation were investigated and the worst-case emissions are reported.

#### 4.1.4 DEVIATION FROM TEST STANDARD

No deviation.

#### 4.1.5 TEST SETUP

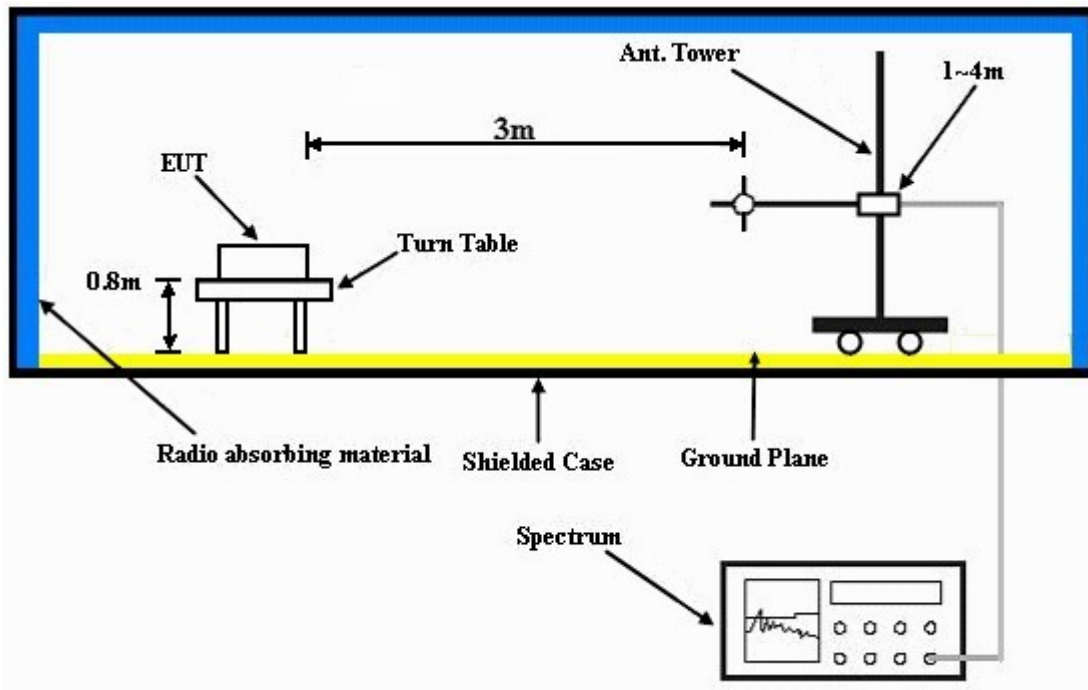

For the actual test configuration, please refer to the attached file (Test Setup Photo).

#### 4.1.6 EUT OPERATING CONDITIONS

##### Test Mode A, B, C

- Connected the EUT to a notebook and placed on a testing table.
- The notebook executes EMC TEST tool to read data and write data to microSD of EUT via USB cable.
- The necessary accessories enable the system in full functions.

##### Test Mode D ~ I

- Connected the EUT to a LCD TV and placed on a testing table.
- The EUT sent and received messages from LCD TV via a HDMI cable.
- The necessary accessories enable the system in full functions.

#### 4.1.7 TEST RESULTS

##### BELOW 1GHz WORST-CASE DATA:

EUT TEST CONDITION		MEASUREMENT DETAIL	
INPUT POWER (SYSTEM)	120 Vac, 60 Hz	FREQUENCY RANGE	Below 1000MHz
ENVIRONMENTAL CONDITIONS	25deg. C, 65%RH 1010 hPa	DETECTOR FUNCTION	Quasi-Peak
TEST MODE	A	TESTED BY	Sun Lin

ANTENNA POLARITY & TEST DISTANCE: HORIZONTAL AT 3 M								
NO.	FREQ. (MHz)	EMISSION LEVEL (dBuV/m)	LIMIT (dBuV/m)	MARGIN (dB)	ANTENNA HEIGHT (m)	TABLE ANGLE (Degree)	RAW VALUE (dBuV)	CORRECTION FACTOR (dB/m)
1	72.67	32.4 QP	40.0	-7.6	1.00 H	199	20.50	11.90
2	192.02	33.3 QP	43.5	-10.2	1.80 H	142	20.50	12.80
3	249.60	34.8 QP	46.0	-11.2	1.50 H	37	21.30	13.50
4	288.49	36.1 QP	46.0	-9.9	1.25 H	313	21.20	14.90
5	576.25	37.5 QP	46.0	-8.5	1.50 H	328	14.30	23.20
6	720.12	37.1 QP	46.0	-8.9	1.00 H	58	11.60	25.50
ANTENNA POLARITY & TEST DISTANCE: VERTICAL AT 3 M								
NO.	FREQ. (MHz)	EMISSION LEVEL (dBuV/m)	LIMIT (dBuV/m)	MARGIN (dB)	ANTENNA HEIGHT (m)	TABLE ANGLE (Degree)	RAW VALUE (dBuV)	CORRECTION FACTOR (dB/m)
1	31.84	30.7 QP	40.0	-9.3	1.00 V	181	17.80	12.90
2	72.94	32.1 QP	40.0	-7.9	1.00 V	25	20.30	11.80
3	216.55	31.3 QP	46.0	-14.7	1.00 V	289	18.70	12.60
4	463.48	29.1 QP	46.0	-16.9	1.00 V	316	8.70	20.40
5	576.25	30.7 QP	46.0	-15.3	1.50 V	64	7.50	23.20
6	720.21	38.4 QP	46.0	-7.6	1.89 V	12	12.90	25.50

- REMARKS:**
1. Emission level (dBuV/m) = Raw Value (dBuV) + Correction Factor (dB/m).
  2. Correction Factor (dB/m) = Antenna Factor (dB/m) + Cable Factor (dB).
  3. The other emission levels were very low against the limit.
  4. Margin value = Emission level – Limit value.



A D T

EUT TEST CONDITION		MEASUREMENT DETAIL	
INPUT POWER (SYSTEM)	120 Vac, 60 Hz	FREQUENCY RANGE	Below 1000MHz
ENVIRONMENTAL CONDITIONS	25deg. C, 65%RH 1010 hPa	DETECTOR FUNCTION	Quasi-Peak
TEST MODE	B	TESTED BY	Sun Lin

ANTENNA POLARITY & TEST DISTANCE: HORIZONTAL AT 3 M								
NO.	FREQ. (MHz)	EMISSION LEVEL (dBuV/m)	LIMIT (dBuV/m)	MARGIN (dB)	ANTENNA HEIGHT (m)	TABLE ANGLE (Degree)	RAW VALUE (dBuV)	CORRECTION FACTOR (dB/m)
1	72.67	29.1 QP	40.0	-10.9	2.00 H	154	17.20	11.90
2	192.07	34.5 QP	43.5	-9.0	1.26 H	336	21.70	12.80
3	265.16	37.6 QP	46.0	-8.4	1.25 H	310	23.50	14.10
4	288.49	35.7 QP	46.0	-10.3	1.00 H	340	20.80	14.90
5	383.76	33.9 QP	46.0	-12.1	1.00 H	202	15.80	18.10
6	576.25	36.8 QP	46.0	-9.2	1.50 H	64	13.60	23.20

ANTENNA POLARITY & TEST DISTANCE: VERTICAL AT 3 M								
NO.	FREQ. (MHz)	EMISSION LEVEL (dBuV/m)	LIMIT (dBuV/m)	MARGIN (dB)	ANTENNA HEIGHT (m)	TABLE ANGLE (Degree)	RAW VALUE (dBuV)	CORRECTION FACTOR (dB/m)
1	30.00	28.9 QP	40.0	-11.1	1.00 V	10	16.10	12.80
2	70.73	31.5 QP	40.0	-8.5	1.00 V	259	19.20	12.30
3	216.55	32.7 QP	46.0	-13.3	1.00 V	265	20.10	12.60
4	383.76	29.5 QP	46.0	-16.5	1.00 V	253	11.40	18.10
5	576.25	32.9 QP	46.0	-13.1	1.00 V	136	9.70	23.20
6	724.01	32.3 QP	46.0	-13.7	1.50 V	256	6.70	25.60

- REMARKS:**
1. Emission level (dBuV/m) = Raw Value (dBuV) + Correction Factor (dB/m).
  2. Correction Factor (dB/m) = Antenna Factor (dB/m) + Cable Factor (dB).
  3. The other emission levels were very low against the limit.
  4. Margin value = Emission level – Limit value.





A D T

EUT TEST CONDITION		MEASUREMENT DETAIL	
INPUT POWER (SYSTEM)	120 Vac, 60 Hz	FREQUENCY RANGE	Below 1000MHz
ENVIRONMENTAL CONDITIONS	25deg. C, 65%RH 1010 hPa	DETECTOR FUNCTION	Quasi-Peak
TEST MODE	C	TESTED BY	Sun Lin

ANTENNA POLARITY & TEST DISTANCE: HORIZONTAL AT 3 M								
NO.	FREQ. (MHz)	EMISSION LEVEL (dBuV/m)	LIMIT (dBuV/m)	MARGIN (dB)	ANTENNA HEIGHT (m)	TABLE ANGLE (Degree)	RAW VALUE (dBuV)	CORRECTION FACTOR (dB/m)
1	72.67	31.0 QP	40.0	-9.0	1.50 H	217	19.10	11.90
2	199.78	37.5 QP	43.5	-6.0	1.25 H	336	25.30	12.20
3	288.49	36.6 QP	46.0	-9.4	1.00 H	331	21.70	14.90
4	383.76	36.2 QP	46.0	-9.8	1.00 H	91	18.10	18.10
5	576.25	32.9 QP	46.0	-13.1	1.25 H	295	9.70	23.20
6	727.90	31.6 QP	46.0	-14.4	1.25 H	319	5.90	25.70

ANTENNA POLARITY & TEST DISTANCE: VERTICAL AT 3 M								
NO.	FREQ. (MHz)	EMISSION LEVEL (dBuV/m)	LIMIT (dBuV/m)	MARGIN (dB)	ANTENNA HEIGHT (m)	TABLE ANGLE (Degree)	RAW VALUE (dBuV)	CORRECTION FACTOR (dB/m)
1	33.79	29.8 QP	40.0	-10.2	1.25 V	232	16.80	13.00
2	216.55	31.6 QP	46.0	-14.4	1.00 V	280	19.00	12.60
3	239.88	32.0 QP	46.0	-14.0	1.25 V	229	18.80	13.20
4	383.76	32.3 QP	46.0	-13.7	1.00 V	241	14.20	18.10
5	480.97	37.0 QP	46.0	-9.0	1.00 V	10	16.20	20.80
6	576.25	37.0 QP	46.0	-9.0	1.00 V	109	13.80	23.20

- REMARKS:**
1. Emission level (dBuV/m) = Raw Value (dBuV) + Correction Factor (dB/m).
  2. Correction Factor (dB/m) = Antenna Factor (dB/m) + Cable Factor (dB).
  3. The other emission levels were very low against the limit.
  4. Margin value = Emission level – Limit value.



A D T

EUT TEST CONDITION		MEASUREMENT DETAIL	
INPUT POWER (SYSTEM)	120 Vac, 60 Hz	FREQUENCY RANGE	Below 1000MHz
ENVIRONMENTAL CONDITIONS	25deg. C, 65%RH 1010 hPa	DETECTOR FUNCTION	Quasi-Peak
TEST MODE	D	TESTED BY	Sun Lin

ANTENNA POLARITY & TEST DISTANCE: HORIZONTAL AT 3 M								
NO.	FREQ. (MHz)	EMISSION LEVEL (dBuV/m)	LIMIT (dBuV/m)	MARGIN (dB)	ANTENNA HEIGHT (m)	TABLE ANGLE (Degree)	RAW VALUE (dBuV)	CORRECTION FACTOR (dB/m)
1	101.84	33.2 QP	43.5	-10.3	1.75 H	7	21.80	11.40
2	222.38	30.5 QP	46.0	-15.5	1.00 H	208	17.70	12.80
3	296.27	30.0 QP	46.0	-16.0	1.00 H	346	14.80	15.20
4	372.09	34.9 QP	46.0	-11.1	1.00 H	58	17.20	17.70
5	519.86	33.7 QP	46.0	-12.3	1.75 H	331	11.90	21.80
6	817.34	35.7 QP	46.0	-10.3	1.50 H	310	8.10	27.60

ANTENNA POLARITY & TEST DISTANCE: VERTICAL AT 3 M								
NO.	FREQ. (MHz)	EMISSION LEVEL (dBuV/m)	LIMIT (dBuV/m)	MARGIN (dB)	ANTENNA HEIGHT (m)	TABLE ANGLE (Degree)	RAW VALUE (dBuV)	CORRECTION FACTOR (dB/m)
1	50.32	36.5 QP	40.0	-3.5	1.22 V	185	22.30	14.20
2	292.38	31.6 QP	46.0	-14.4	1.25 V	13	16.60	15.00
3	372.09	33.2 QP	46.0	-12.8	1.25 V	349	15.50	17.70
4	519.86	34.8 QP	46.0	-11.2	1.00 V	10	13.00	21.80
5	737.62	35.1 QP	46.0	-10.9	1.00 V	31	9.20	25.90
6	817.34	34.0 QP	46.0	-12.0	1.00 V	10	6.40	27.60

- REMARKS:**
1. Emission level (dBuV/m) = Raw Value (dBuV) + Correction Factor (dB/m).
  2. Correction Factor (dB/m) = Antenna Factor (dB/m) + Cable Factor (dB).
  3. The other emission levels were very low against the limit.
  4. Margin value = Emission level – Limit value.



A D T

EUT TEST CONDITION		MEASUREMENT DETAIL	
INPUT POWER (SYSTEM)	120 Vac, 60 Hz	FREQUENCY RANGE	Below 1000MHz
ENVIRONMENTAL CONDITIONS	25deg. C, 65%RH 1010 hPa	DETECTOR FUNCTION	Quasi-Peak
TEST MODE	E	TESTED BY	Sun Lin

ANTENNA POLARITY & TEST DISTANCE: HORIZONTAL AT 3 M								
NO.	FREQ. (MHz)	EMISSION LEVEL (dBuV/m)	LIMIT (dBuV/m)	MARGIN (dB)	ANTENNA HEIGHT (m)	TABLE ANGLE (Degree)	RAW VALUE (dBuV)	CORRECTION FACTOR (dB/m)
1	50.12	36.2 QP	40.0	-3.8	1.00 H	22	22.00	14.20
2	296.27	35.1 QP	46.0	-10.9	1.50 H	22	19.90	15.20
3	372.09	32.4 QP	46.0	-13.6	1.25 H	352	14.70	17.70
4	445.98	32.4 QP	46.0	-13.6	1.00 H	10	12.50	19.90
5	515.97	34.1 QP	46.0	-11.9	1.00 H	73	12.40	21.70
6	737.62	33.4 QP	46.0	-12.6	1.00 H	34	7.50	25.90

ANTENNA POLARITY & TEST DISTANCE: VERTICAL AT 3 M								
NO.	FREQ. (MHz)	EMISSION LEVEL (dBuV/m)	LIMIT (dBuV/m)	MARGIN (dB)	ANTENNA HEIGHT (m)	TABLE ANGLE (Degree)	RAW VALUE (dBuV)	CORRECTION FACTOR (dB/m)
1	49.52	36.5 QP	40.0	-3.5	1.00 V	198	22.20	14.30
2	222.38	31.2 QP	46.0	-14.8	1.25 V	64	18.40	12.80
3	296.27	34.1 QP	46.0	-11.9	1.25 V	28	18.90	15.20
4	372.09	32.3 QP	46.0	-13.7	1.75 V	193	14.60	17.70
5	519.86	34.0 QP	46.0	-12.0	1.00 V	346	12.20	21.80
6	737.62	34.9 QP	46.0	-11.1	1.00 V	43	9.00	25.90

- REMARKS:**
1. Emission level (dBuV/m) = Raw Value (dBuV) + Correction Factor (dB/m).
  2. Correction Factor (dB/m) = Antenna Factor (dB/m) + Cable Factor (dB).
  3. The other emission levels were very low against the limit.
  4. Margin value = Emission level – Limit value.



A D T

EUT TEST CONDITION		MEASUREMENT DETAIL	
INPUT POWER (SYSTEM)	120 Vac, 60 Hz	FREQUENCY RANGE	Below 1000MHz
ENVIRONMENTAL CONDITIONS	25deg. C, 65%RH 1010 hPa	DETECTOR FUNCTION	Quasi-Peak
TEST MODE	F	TESTED BY	Sun Lin

**ANTENNA POLARITY & TEST DISTANCE: HORIZONTAL AT 3 M**

NO.	FREQ. (MHz)	EMISSION LEVEL (dBuV/m)	LIMIT (dBuV/m)	MARGIN (dB)	ANTENNA HEIGHT (m)	TABLE ANGLE (Degree)	RAW VALUE (dBuV)	CORRECTION FACTOR (dB/m)
1	222.38	41.3 QP	46.0	-4.7	1.50 H	358	28.50	12.80
2	298.21	35.8 QP	46.0	-10.2	1.00 H	220	20.60	15.20
3	372.09	34.6 QP	46.0	-11.4	1.00 H	352	16.90	17.70
4	519.86	35.1 QP	46.0	-10.9	2.00 H	106	13.30	21.80
5	669.57	41.8 QP	46.0	-4.2	1.25 H	64	17.20	24.60
6	817.34	37.6 QP	46.0	-8.4	2.00 H	322	10.00	27.60

**ANTENNA POLARITY & TEST DISTANCE: VERTICAL AT 3 M**

NO.	FREQ. (MHz)	EMISSION LEVEL (dBuV/m)	LIMIT (dBuV/m)	MARGIN (dB)	ANTENNA HEIGHT (m)	TABLE ANGLE (Degree)	RAW VALUE (dBuV)	CORRECTION FACTOR (dB/m)
1	58.80	35.5 QP	40.0	-4.5	1.00 V	25	21.20	14.30
2	222.38	37.1 QP	46.0	-8.9	1.25 V	70	24.30	12.80
3	372.09	30.2 QP	46.0	-15.8	2.00 V	37	12.50	17.70
4	519.86	36.1 QP	46.0	-9.9	1.25 V	340	14.30	21.80
5	669.57	36.9 QP	46.0	-9.1	1.00 V	340	12.30	24.60
6	817.34	35.4 QP	46.0	-10.6	1.00 V	286	7.80	27.60

- REMARKS:**
1. Emission level (dBuV/m) = Raw Value (dBuV) + Correction Factor (dB/m).
  2. Correction Factor (dB/m) = Antenna Factor (dB/m) + Cable Factor (dB).
  3. The other emission levels were very low against the limit.
  4. Margin value = Emission level – Limit value.



A D T

EUT TEST CONDITION		MEASUREMENT DETAIL	
INPUT POWER (SYSTEM)	120 Vac, 60 Hz	FREQUENCY RANGE	Below 1000MHz
ENVIRONMENTAL CONDITIONS	25deg. C, 65%RH 1010 hPa	DETECTOR FUNCTION	Quasi-Peak
TEST MODE	G	TESTED BY	Sun Lin

ANTENNA POLARITY & TEST DISTANCE: HORIZONTAL AT 3 M								
NO.	FREQ. (MHz)	EMISSION LEVEL (dBuV/m)	LIMIT (dBuV/m)	MARGIN (dB)	ANTENNA HEIGHT (m)	TABLE ANGLE (Degree)	RAW VALUE (dBuV)	CORRECTION FACTOR (dB/m)
1	148.55	42.2 QP	43.5	-1.3	1.51 H	77	27.50	14.70
2	222.38	36.6 QP	46.0	-9.4	1.25 H	1	23.80	12.80
3	296.27	39.8 QP	46.0	-6.2	1.00 H	316	24.60	15.20
4	371.42	43.3 QP	46.0	-2.7	1.00 H	0	25.60	17.70
5	445.98	40.6 QP	46.0	-5.4	1.50 H	19	20.70	19.90
6	593.74	36.9 QP	46.0	-9.1	1.25 H	337	13.30	23.60

ANTENNA POLARITY & TEST DISTANCE: VERTICAL AT 3 M								
NO.	FREQ. (MHz)	EMISSION LEVEL (dBuV/m)	LIMIT (dBuV/m)	MARGIN (dB)	ANTENNA HEIGHT (m)	TABLE ANGLE (Degree)	RAW VALUE (dBuV)	CORRECTION FACTOR (dB/m)
1	49.65	37.5 QP	40.0	-2.5	1.00 V	16	23.20	14.30
2	74.30	38.8 QP	40.0	-1.2	1.00 V	92	27.30	11.50
3	148.50	33.2 QP	43.5	-10.3	1.00 V	154	18.50	14.70
4	372.09	39.3 QP	46.0	-6.7	1.75 V	169	21.60	17.70
5	445.98	40.4 QP	46.0	-5.6	1.75 V	346	20.50	19.90
6	817.34	32.3 QP	46.0	-13.7	1.00 V	34	4.70	27.60

- REMARKS:**
1. Emission level (dBuV/m) = Raw Value (dBuV) + Correction Factor (dB/m).
  2. Correction Factor (dB/m) = Antenna Factor (dB/m) + Cable Factor (dB).
  3. The other emission levels were very low against the limit.
  4. Margin value = Emission level – Limit value.



A D T

EUT TEST CONDITION		MEASUREMENT DETAIL	
INPUT POWER (SYSTEM)	120 Vac, 60 Hz	FREQUENCY RANGE	Below 1000MHz
ENVIRONMENTAL CONDITIONS	25deg. C, 65%RH 1010 hPa	DETECTOR FUNCTION	Quasi-Peak
TEST MODE	H	TESTED BY	Sun Lin

ANTENNA POLARITY & TEST DISTANCE: HORIZONTAL AT 3 M								
NO.	FREQ. (MHz)	EMISSION LEVEL (dBuV/m)	LIMIT (dBuV/m)	MARGIN (dB)	ANTENNA HEIGHT (m)	TABLE ANGLE (Degree)	RAW VALUE (dBuV)	CORRECTION FACTOR (dB/m)
1	148.57	42.4 QP	43.5	-1.1	1.56 H	107	27.70	14.70
2	222.38	37.7 QP	46.0	-8.3	1.00 H	343	24.90	12.80
3	296.27	38.9 QP	46.0	-7.1	1.00 H	337	23.70	15.20
4	372.09	42.4 QP	46.0	-3.6	1.00 H	55	24.70	17.70
5	445.98	41.2 QP	46.0	-4.8	1.00 H	244	21.30	19.90
6	519.86	36.3 QP	46.0	-9.7	1.50 H	31	14.50	21.80

ANTENNA POLARITY & TEST DISTANCE: VERTICAL AT 3 M								
NO.	FREQ. (MHz)	EMISSION LEVEL (dBuV/m)	LIMIT (dBuV/m)	MARGIN (dB)	ANTENNA HEIGHT (m)	TABLE ANGLE (Degree)	RAW VALUE (dBuV)	CORRECTION FACTOR (dB/m)
1	49.34	35.9 QP	40.0	-4.1	1.00 V	13	21.60	14.30
2	74.29	39.0 QP	40.0	-1.0	1.00 V	40	27.50	11.50
3	148.50	36.0 QP	43.5	-7.5	1.50 V	40	21.30	14.70
4	296.27	33.7 QP	46.0	-12.3	1.25 V	52	18.50	15.20
5	372.09	39.2 QP	46.0	-6.8	1.00 V	268	21.50	17.70
6	445.98	41.3 QP	46.0	-4.7	1.00 V	139	21.40	19.90

- REMARKS:**
1. Emission level (dBuV/m) = Raw Value (dBuV) + Correction Factor (dB/m).
  2. Correction Factor (dB/m) = Antenna Factor (dB/m) + Cable Factor (dB).
  3. The other emission levels were very low against the limit.
  4. Margin value = Emission level – Limit value.



A D T

EUT TEST CONDITION		MEASUREMENT DETAIL	
INPUT POWER (SYSTEM)	120 Vac, 60 Hz	FREQUENCY RANGE	Below 1000MHz
ENVIRONMENTAL CONDITIONS	25deg. C, 65%RH 1010 hPa	DETECTOR FUNCTION	Quasi-Peak
TEST MODE	I	TESTED BY	Sun Lin

ANTENNA POLARITY & TEST DISTANCE: HORIZONTAL AT 3 M								
NO.	FREQ. (MHz)	EMISSION LEVEL (dBuV/m)	LIMIT (dBuV/m)	MARGIN (dB)	ANTENNA HEIGHT (m)	TABLE ANGLE (Degree)	RAW VALUE (dBuV)	CORRECTION FACTOR (dB/m)
1	148.57	42.3 QP	43.5	-1.2	2.24 H	94	27.60	14.70
2	296.27	39.0 QP	46.0	-7.0	1.00 H	352	23.80	15.20
3	371.42	44.9 QP	46.0	-1.1	1.00 H	166	27.20	17.70
4	445.98	40.8 QP	46.0	-5.2	1.75 H	328	20.90	19.90
5	593.74	33.5 QP	46.0	-12.5	1.50 H	226	9.90	23.60
6	817.34	35.0 QP	46.0	-11.0	1.00 H	43	7.40	27.60

ANTENNA POLARITY & TEST DISTANCE: VERTICAL AT 3 M								
NO.	FREQ. (MHz)	EMISSION LEVEL (dBuV/m)	LIMIT (dBuV/m)	MARGIN (dB)	ANTENNA HEIGHT (m)	TABLE ANGLE (Degree)	RAW VALUE (dBuV)	CORRECTION FACTOR (dB/m)
1	49.84	37.9 QP	40.0	-2.1	1.23 V	43	23.70	14.20
2	74.27	39.0 QP	40.0	-1.0	1.00 V	39	27.50	11.50
3	148.50	37.0 QP	43.5	-6.5	1.75 V	121	22.30	14.70
4	372.09	42.9 QP	46.0	-3.1	1.75 V	199	25.20	17.70
5	445.98	38.4 QP	46.0	-7.6	1.00 V	142	18.50	19.90
6	593.74	37.2 QP	46.0	-8.8	1.00 V	193	13.60	23.60

- REMARKS:**
1. Emission level (dBuV/m) = Raw Value (dBuV) + Correction Factor (dB/m).
  2. Correction Factor (dB/m) = Antenna Factor (dB/m) + Cable Factor (dB).
  3. The other emission levels were very low against the limit.
  4. Margin value = Emission level – Limit value.

## 4.2 CONDUCTED EMISSION MEASUREMENT

### 4.2.1 LIMITS OF CONDUCTED EMISSION MEASUREMENT

FREQUENCY OF EMISSION (MHz)	CONDUCTED LIMIT (dB $\mu$ V)	
	Quasi-peak	Average
0.15-0.5	66 to 56	56 to 46
0.5-5	56	46
5-30	60	50

- NOTE:**
1. The lower limit shall apply at the transition frequencies.
  2. The limit decreases in line with the logarithm of the frequency in the range of 0.15 to 0.50 MHz.
  3. All emanations from a class A/B digital device or system, including any network of conductors and apparatus connected thereto, shall not exceed the level of field strengths specified above.

### 4.2.2 TEST INSTRUMENTS

DESCRIPTION & MANUFACTURER	MODEL NO.	SERIAL NO.	DATE OF CALIBRATION	DUE DATE OF CALIBRATION
Test Receiver ROHDE & SCHWARZ	ESCS30	100289	Nov. 23, 2010	Nov. 22, 2011
RF signal cable Woken	5D-FB	Cable-HYCO2-01	Dec. 30, 2010	Dec. 29, 2011
LISN ROHDE & SCHWARZ	ESH2-Z5	100100	Jan. 06, 2011	Jan. 05, 2012
LISN ROHDE & SCHWARZ	ESH3-Z5	100311	Jul. 08, 2010	Jul. 07, 2011
V-LISN SCHWARZBECK	NNBL 8226-2	8226-142	Jul. 12, 2010	Jul. 11, 2011
LISN ROHDE & SCHWARZ	ENV216	100072	Jun. 11, 2010	Jun. 10, 2011
Software ADT	ADT_Cond_ V7.3.7	NA	NA	NA

- NOTE:**
1. The calibration interval of the above test instruments is 12 months and the calibrations are traceable to NML/ROC and NIST/USA.
  2. The test was performed in HwaYa Shielded Room 2.
  3. The VCCI Site Registration No. is C-2047.



#### 4.2.3 TEST PROCEDURES

- a. The EUT was placed 0.4 meters from the conducting wall of the shielded room with EUT being connected to the power mains through a line impedance stabilization network (LISN). Other support units were connected to the power mains through another LISN. The two LISNs provide 50 ohm/ 50uH of coupling impedance for the measuring instrument.
- b. Both lines of the power mains connected to the EUT were checked for maximum conducted interference.
- c. The frequency range from 150kHz to 30MHz was searched. Emission levels under (Limit - 20dB) was not recorded.

**NOTE:** All modes of operation were investigated and the worst-case emissions are reported.

#### 4.2.4 DEVIATION FROM TEST STANDARD

No deviation.

#### 4.2.5 TEST SETUP

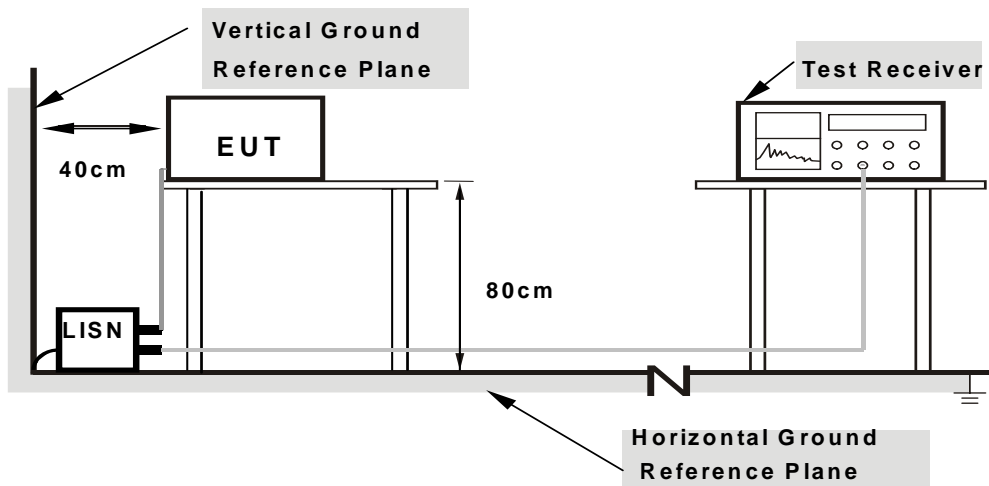

- Note:**
1. Support units were connected to second LISN.
  2. Both of LISNs (AMN) are 80 cm from EUT and at least 80 from other units and other metal planes

For the actual test configuration, please refer to the attached file (Test Setup Photo).

#### 4.2.6 EUT OPERATING CONDITIONS

Same as item 4.1.6.

### 4.2.7 TEST RESULTS

#### CONDUCTED WORST-CASE DATA:

PHASE	Line 1	6dB BANDWIDTH	9kHz
TEST MODE	A		

No	Freq. [MHz]	Corr. Factor (dB)	Reading Value		Emission Level		Limit		Margin	
			[dB (uV)]		[dB (uV)]		[dB (uV)]		(dB)	
			Q.P.	AV.	Q.P.	AV.	Q.P.	AV.	Q.P.	AV.
1	0.189	0.15	46.19	-	46.34	-	64.08	54.08	-17.74	-
2	0.269	0.16	33.70	-	33.86	-	61.16	51.16	-27.31	-
3	0.478	0.17	35.29	-	35.46	-	56.37	46.37	-20.91	-
4	0.771	0.18	34.01	-	34.19	-	56.00	46.00	-21.81	-
5	2.176	0.23	33.07	-	33.30	-	56.00	46.00	-22.70	-
6	12.730	0.73	43.51	-	44.24	-	60.00	50.00	-15.76	-

- REMARKS:**
1. Q.P. and AV. are abbreviations of quasi-peak and average individually.
  2. "-": The Quasi-peak reading value also meets average limit and measurement with the average detector is unnecessary.
  3. The emission levels of other frequencies were very low against the limit.
  4. Margin value = Emission level - Limit value
  5. Correction factor = Insertion loss + Cable loss
  6. Emission Level = Correction Factor + Reading Value.

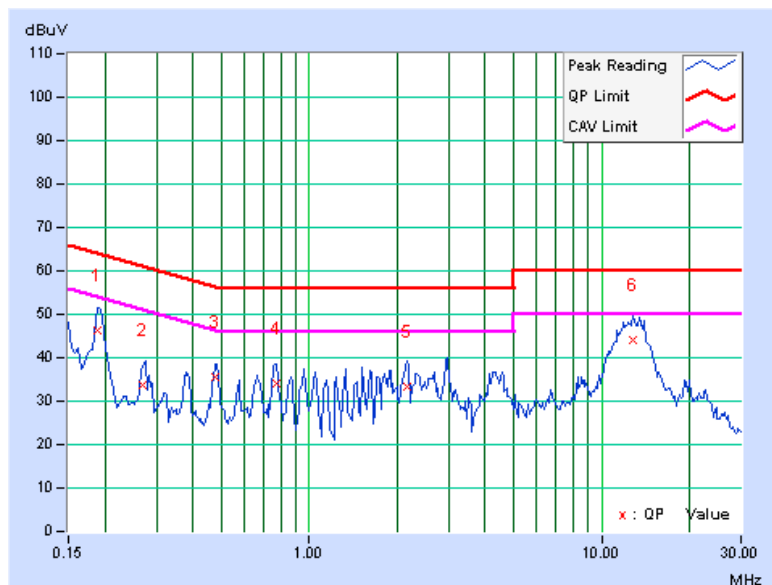

PHASE	Line 2	6dB BANDWIDTH	9kHz
TEST MODE	A		

No	Freq. [MHz]	Corr. Factor (dB)	Reading Value		Emission Level		Limit		Margin	
			[dB (uV)]		[dB (uV)]		[dB (uV)]		(dB)	
			Q.P.	AV.	Q.P.	AV.	Q.P.	AV.	Q.P.	AV.
1	0.189	0.17	49.52	-	49.69	-	64.08	54.08	-14.39	-
2	0.759	0.20	40.86	-	41.06	-	56.00	46.00	-14.94	-
3	1.055	0.21	40.91	-	41.12	-	56.00	46.00	-14.88	-
4	2.191	0.24	40.07	-	40.31	-	56.00	46.00	-15.69	-
5	4.563	0.34	37.84	-	38.18	-	56.00	46.00	-17.82	-
6	13.648	0.67	43.62	-	44.29	-	60.00	50.00	-15.71	-

- REMARKS:**
1. Q.P. and AV. are abbreviations of quasi-peak and average individually.
  2. "-": The Quasi-peak reading value also meets average limit and measurement with the average detector is unnecessary.
  3. The emission levels of other frequencies were very low against the limit.
  4. Margin value = Emission level - Limit value
  5. Correction factor = Insertion loss + Cable loss
  6. Emission Level = Correction Factor + Reading Value.

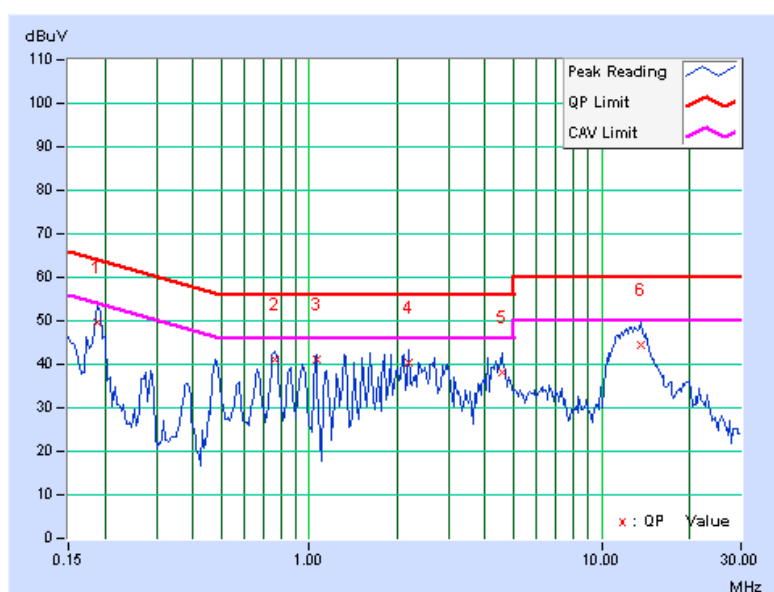

PHASE	Line 1	6dB BANDWIDTH	9kHz
TEST MODE	D		

No	Freq. [MHz]	Corr. Factor (dB)	Reading Value		Emission Level		Limit		Margin	
			[dB (uV)]		[dB (uV)]		[dB (uV)]		(dB)	
			Q.P.	AV.	Q.P.	AV.	Q.P.	AV.	Q.P.	AV.
1	0.189	0.15	43.28	-	43.43	-	64.08	54.08	-20.65	-
2	0.392	0.17	40.37	-	40.54	-	58.02	48.02	-17.48	-
3	0.588	0.18	36.90	-	37.08	-	56.00	46.00	-18.92	-
4	0.884	0.19	30.40	-	30.59	-	56.00	46.00	-25.41	-
5	3.051	0.27	38.40	-	38.67	-	56.00	46.00	-17.33	-
6	4.797	0.35	38.28	-	38.63	-	56.00	46.00	-17.37	-

- REMARKS:**
1. Q.P. and AV. are abbreviations of quasi-peak and average individually.
  2. "-": The Quasi-peak reading value also meets average limit and measurement with the average detector is unnecessary.
  3. The emission levels of other frequencies were very low against the limit.
  4. Margin value = Emission level - Limit value
  5. Correction factor = Insertion loss + Cable loss
  6. Emission Level = Correction Factor + Reading Value.

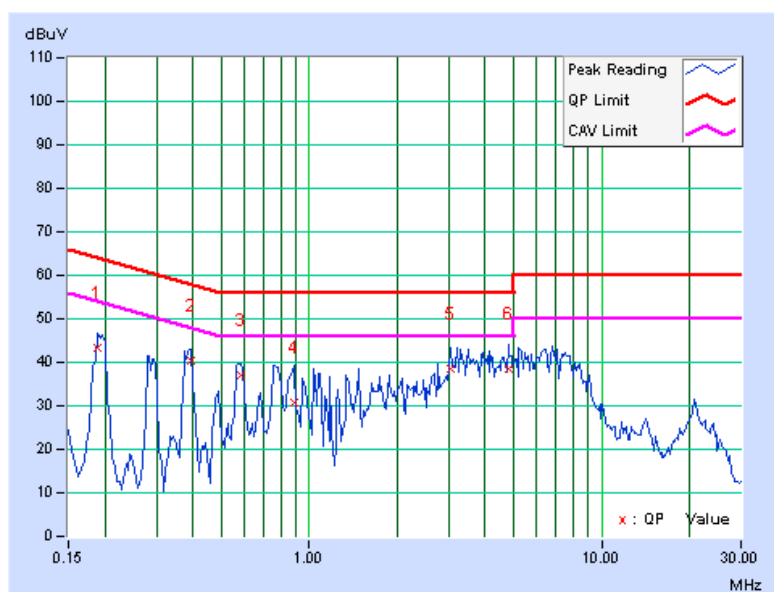

PHASE	Line 2	6dB BANDWIDTH	9kHz
TEST MODE	D		

No	Freq. [MHz]	Corr. Factor (dB)	Reading Value		Emission Level		Limit		Margin	
			[dB (uV)]		[dB (uV)]		[dB (uV)]		(dB)	
			Q.P.	AV.	Q.P.	AV.	Q.P.	AV.	Q.P.	AV.
1	0.197	0.17	46.57	-	46.74	-	63.74	53.74	-17.00	-
2	0.591	0.20	43.17	-	43.37	-	56.00	46.00	-12.63	-
3	0.884	0.21	39.92	-	40.13	-	56.00	46.00	-15.87	-
4	4.148	0.32	45.17	-	45.49	-	56.00	46.00	-10.51	-
<b>5</b>	<b>7.406</b>	<b>0.42</b>	<b>52.44</b>	<b>41.30</b>	<b>52.86</b>	<b>41.72</b>	<b>60.00</b>	<b>50.00</b>	<b>-7.14</b>	<b>-8.28</b>
6	20.285	0.93	34.80	-	35.73	-	60.00	50.00	-24.27	-

- REMARKS:**
1. Q.P. and AV. are abbreviations of quasi-peak and average individually.
  2. "-": The Quasi-peak reading value also meets average limit and measurement with the average detector is unnecessary.
  3. The emission levels of other frequencies were very low against the limit.
  4. Margin value = Emission level - Limit value
  5. Correction factor = Insertion loss + Cable loss
  6. Emission Level = Correction Factor + Reading Value.

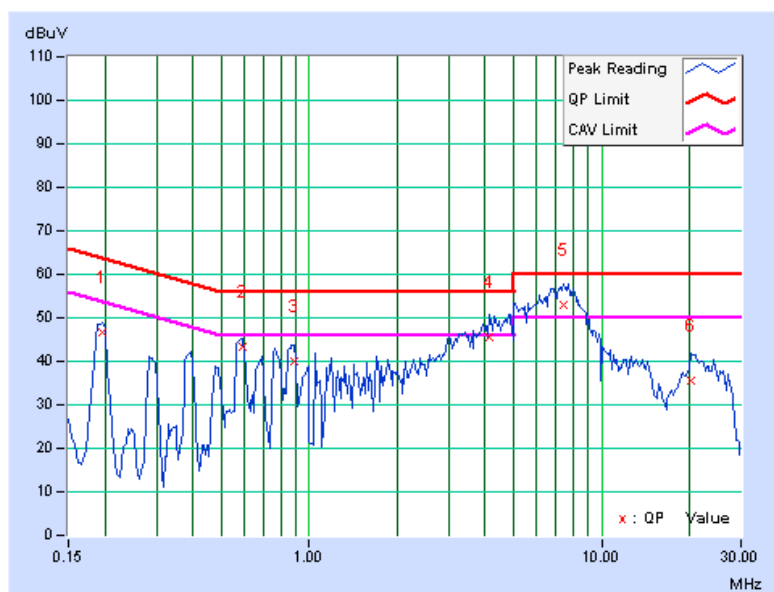

<b>PHASE</b>	Line 1	<b>6dB BANDWIDTH</b>	9kHz
<b>TEST MODE</b>	G		

No	Freq. [MHz]	Corr. Factor (dB)	Reading Value		Emission Level		Limit		Margin	
			[dB (uV)]		[dB (uV)]		[dB (uV)]		(dB)	
			Q.P.	AV.	Q.P.	AV.	Q.P.	AV.	Q.P.	AV.
1	0.201	0.15	45.50	-	45.65	-	63.58	53.58	-17.93	-
2	0.322	0.16	36.07	-	36.23	-	59.66	49.66	-23.43	-
3	0.451	0.17	32.48	-	32.65	-	56.86	46.86	-24.21	-
4	0.931	0.19	28.70	-	28.89	-	56.00	46.00	-27.11	-
5	3.414	0.29	35.04	-	35.33	-	56.00	46.00	-20.67	-
6	7.508	0.46	30.77	-	31.23	-	60.00	50.00	-28.77	-

- REMARKS:**
1. Q.P. and AV. are abbreviations of quasi-peak and average individually.
  2. "-": The Quasi-peak reading value also meets average limit and measurement with the average detector is unnecessary.
  3. The emission levels of other frequencies were very low against the limit.
  4. Margin value = Emission level - Limit value
  5. Correction factor = Insertion loss + Cable loss
  6. Emission Level = Correction Factor + Reading Value.

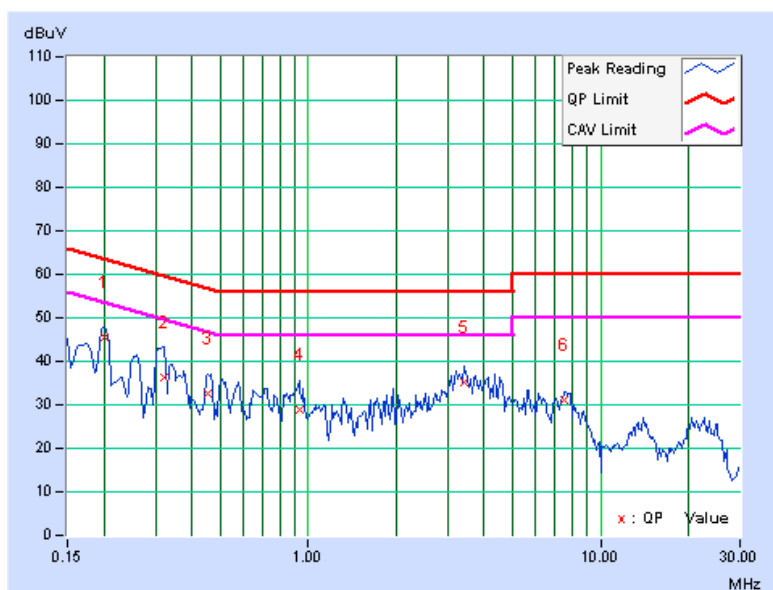

PHASE	Line 2	6dB BANDWIDTH	9kHz
TEST MODE	G		

No	Freq. [MHz]	Corr. Factor (dB)	Reading Value		Emission Level		Limit		Margin	
			[dB (uV)]		[dB (uV)]		[dB (uV)]		(dB)	
			Q.P.	AV.	Q.P.	AV.	Q.P.	AV.	Q.P.	AV.
1	0.158	0.16	18.37	-	18.53	-	65.58	55.58	-47.05	-
2	0.193	0.17	47.28	-	47.45	-	63.91	53.91	-16.46	-
3	0.584	0.20	41.94	-	42.14	-	56.00	46.00	-13.86	-
4	3.344	0.29	41.64	-	41.93	-	56.00	46.00	-14.07	-
5	4.777	0.34	44.78	-	45.12	-	56.00	46.00	-10.88	-
6	7.813	0.43	47.60	-	48.03	-	60.00	50.00	-11.97	-

- REMARKS:**
1. Q.P. and AV. are abbreviations of quasi-peak and average individually.
  2. "-": The Quasi-peak reading value also meets average limit and measurement with the average detector is unnecessary.
  3. The emission levels of other frequencies were very low against the limit.
  4. Margin value = Emission level - Limit value
  5. Correction factor = Insertion loss + Cable loss
  6. Emission Level = Correction Factor + Reading Value.

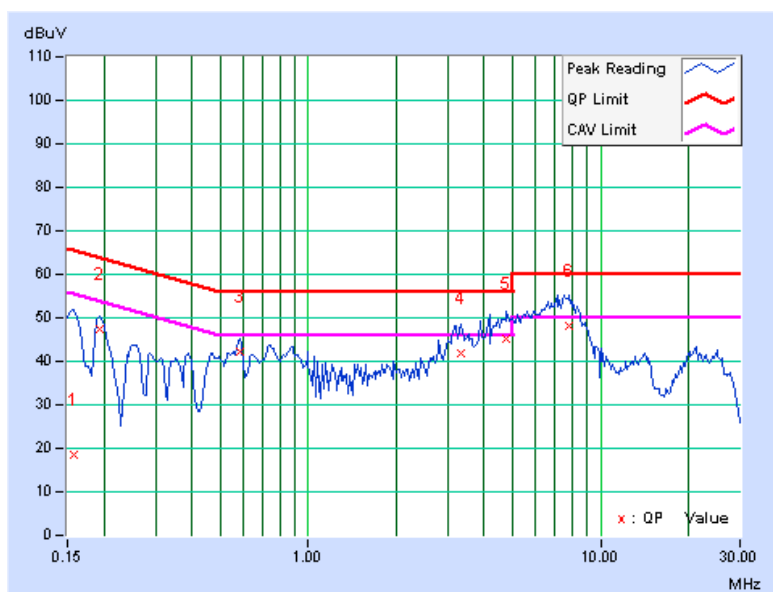



## 5. PHOTOGRAPHS OF THE TEST CONFIGURATION

Please refer to the attached file (Test Setup Photo).



## 6. INFORMATION ON THE TESTING LABORATORIES

We, Bureau Veritas Consumer Products Services (H.K.) Ltd., Taoyuan Branch, were founded in 1988 to provide our best service in EMC, Radio, Telecom and Safety consultation. Our laboratories are accredited and approved according to ISO/IEC 17025.

Copies of accreditation certificates of our laboratories obtained from approval agencies can be downloaded from our web site:

[www.adt.com.tw/index.5.phtml](http://www.adt.com.tw/index.5.phtml). If you have any comments, please feel free to contact us at the following:

**Linko EMC/RF Lab:**

Tel: 886-2-26052180

Fax: 886-2-26051924

**Hsin Chu EMC/RF Lab:**

Tel: 886-3-5935343

Fax: 886-3-5935342

**Hwa Ya EMC/RF/Safety Telecom Lab:**

Tel: 886-3-3183232

Fax: 886-3-3185050

**Web Site:** [www.adt.com.tw](http://www.adt.com.tw)

The address and road map of all our labs can be found in our web site also.

## **7. APPENDIX A - MODIFICATIONS RECORDERS FOR ENGINEERING CHANGES TO THE EUT BY THE LAB**

No any modifications are made to the EUT by the lab during the test.

**--- END ---**