



FCC TEST REPORT (PART 22)

REPORT NO.: RF990129L10-1
MODEL NO.: F-08B
RECEIVED: Feb. 01, 2010
TESTED: Feb. 05 ~ Mar. 03, 2010
ISSUED: Mar. 03, 2010

APPLICANT: FUJITSU LIMITED

ADDRESS: 1-1, Kamikodanaka 4-chome, Nakahara-ku, Kawasaki
211-8588, Japan

ISSUED BY: Bureau Veritas Consumer Products Services (H.K.)
Ltd., Taoyuan Branch

LAB ADDRESS: No. 47, 14th Ling, Chia Pau Tsuen, Lin Kou Hsiang,
Taipei Hsien 244, Taiwan, R.O.C.

TEST LOCATION: No. 19, Hwa Ya 2nd Rd, Wen Hwa Tsuen, Kwei Shan
Hsiang, Taoyuan Hsien 333, Taiwan, R.O.C.

This test report consists of 47 pages in total. It may be duplicated completely for legal use with the approval of the applicant. It should not be reproduced except in full, without the written approval of our laboratory. The client should not use it to claim product endorsement by TAF or any government agencies. The test results in the report only apply to the tested sample.





TABLE OF CONTENTS

1	CERTIFICATION	3
2	SUMMARY OF TEST RESULTS	4
2.1	MEASUREMENT UNCERTAINTY	4
3	GENERAL INFORMATION.....	5
3.1	GENERAL DESCRIPTION OF EUT	5
3.2	DESCRIPTION OF TEST MODES.....	6
3.2.1	CONFIGURATION OF SYSTEM UNDER TEST	7
3.2.2	TEST MODE APPLICABILITY AND TESTED CHANNEL DETAIL	8
3.3	GENERAL DESCRIPTION OF APPLIED STANDARDS	10
3.4	DESCRIPTION OF SUPPORT UNITS	10
4	TEST TYPES AND RESULTS.....	11
4.1	OUTPUT POWER MEASUREMENT	11
4.1.1	LIMITS OF OUTPUT POWER MEASUREMENT	11
4.1.2	TEST INSTRUMENTS	12
4.1.3	TEST PROCEDURES	13
4.1.4	TEST SETUP	14
4.1.5	EUT OPERATING CONDITIONS.....	15
4.1.6	TEST RESULTS	16
4.2	RADIATED EMISSION MEASUREMENT (BELOW 1GHZ)	18
4.2.1	LIMITS OF RADIATED EMISSION MEASUREMENT	18
4.2.2	TEST INSTRUMENTS	18
4.2.3	TEST PROCEDURES	19
4.2.4	DEVIATION FROM TEST STANDARD	19
4.2.5	TEST SETUP	20
4.2.6	EUT OPERATING CONDITIONS.....	20
4.2.7	TEST RESULTS	21
4.3	RADIATED EMISSION MEASUREMENT (ABOVE 1GHZ).....	27
4.3.1	LIMITS OF RADIATED EMISSION MEASUREMENT	27
4.3.2	TEST INSTRUMENTS	27
4.3.3	TEST PROCEDURES	27
4.3.4	DEVIATION FROM TEST STANDARD	27
4.3.5	TEST SETUP	27
4.3.6	EUT OPERATING CONDITIONS.....	27
4.3.7	TEST RESULTS	28
4.4	CONDUCTED EMISSION MEASUREMENT	40
4.4.1	LIMITS OF CONDUCTED EMISSION MEASUREMENT	40
4.4.2	TEST INSTRUMENTS	40
4.4.3	TEST PROCEDURES	41
4.4.4	DEVIATION FROM TEST STANDARD	41
4.4.5	TEST SETUP	42
4.4.6	EUT OPERATING CONDITIONS.....	42
4.4.7	TEST RESULTS	43
5	PHOTOGRAPHS OF THE TEST CONFIGURATION.....	45
6	INFORMATION ON THE TESTING LABORATORIES	46
7	APPENDIX A – MODIFICATIONS RECORDERS FOR ENGINEERING CHANGES TO THE EUT BY THE LAB.....	47



A D T

1 CERTIFICATION

PRODUCT: Mobile phone
MODEL NO.: F-08B
BRAND: FOMA
APPLICANT: FUJITSU LIMITED
TESTED: Feb. 05 ~ Mar. 03, 2010
TEST SAMPLE: ENGINEERING SAMPLE
STANDARDS: **FCC Part 22, Subpart H**
ANSI C63.4-2003
TEST ITEM: **Maximum Peak Output Power (Section 2.1046**
22.913 (a))
Radiated Spurious Emissions (Section 2.1053
22.917)
AC Power Conducted Emission (Section 15.207)

The above equipment (model: F-08B) has been tested by **Bureau Veritas Consumer Products Services (H.K.) Ltd., Taoyuan Branch**. The test record, data evaluation & Equipment Under Test (EUT) configurations represented herein are true and accurate accounts of the measurements of the sample's EMC characteristics under the conditions specified in this report.

PREPARED BY : Polly Chien , **DATE** : Mar. 03, 2010
Polly Chien / Specialist

TECHNICAL ACCEPTANCE : Long Chen , **DATE** : Mar. 03, 2010
Responsible for RF Long Chen / Senior Engineer

APPROVED BY : Gary Chang , **DATE** : Mar. 03, 2010
Gary Chang / Assistant Manager

2 SUMMARY OF TEST RESULTS

The EUT has been tested according to the following specifications:

APPLIED STANDARD: FCC Part 22 & Part 2			
STANDARD SECTION	TEST TYPE AND LIMIT	RESULT	REMARK
2.1046 22.913 (a)	Maximum Peak Output Power Limit: max. 7 watts e.r.p peak power	PASS	Meet the requirement of limit. Minimum passing margin is 22.2dBm at 836.4MHz.
2.1053 22.917	Radiated Spurious Emissions	PASS	Meet the requirement of limit. Minimum passing margin is -19.7dB at 1652.80MHz & 1672.80 MHz.
15.207	AC Power Conducted Emission	PASS	Meet the requirement of limit. Minimum passing margin is -19.00dB at 2.914MHz.

2.1 MEASUREMENT UNCERTAINTY

Where relevant, the following measurement uncertainty levels have been estimated for tests performed on the EUT as specified in CISPR 16-4-2:

MEASUREMENT	FREQUENCY	UNCERTAINTY
Conducted emissions	150kHz~30MHz	2.44 dB
Radiated emissions	30MHz ~ 200MHz	3.34 dB
	200MHz ~1000MHz	3.35 dB
	1GHz ~ 18GHz	2.26 dB
	18GHz ~ 40GHz	1.94 dB

This uncertainty represents an expanded uncertainty expressed at approximately the 95% confidence level using a coverage factor of k=2.



3 GENERAL INFORMATION

3.1 GENERAL DESCRIPTION OF EUT

EUT	Mobile phone
MODEL NO.	F-08B
FCC ID	VQK-F08B
POWER SUPPLY	3.7Vdc (Li-ion battery) 5.4Vdc (Adapter)
MODULATION TYPE	WCDMA (Band 5) / HSDPA
OPERATING FREQUENCY	Tx Frequency: 824.2MHz ~ 848.8MHz (850MHz band) Rx Frequency: 869.2MHz ~ 893.8MHz (850MHz band)
NUMBER OF CHANNEL	102
ANTENNA TYPE	Integral antenna
MAX. ANTENNA GAIN	Integral antenna with 0dBi gain (EUT Open) Integral antenna with -2dBi gain (EUT Close)
DATA CABLE	NA
I/O PORTS	Refer to user's manual
ACCESSORY DEVICES	Battery

NOTE:

1. The EUT is a Mobile phone. The functions of EUT listed as below:

	TEST STANDARD	REFERENCE REPORT
RFID	FCC Part 15	RF990129L10
WCDMA 850	FCC Part 22	RF990129L10-1

2. In this report, only included test item of radiated spurious emissions per client's requests.

3. The EUT is powered by the following adapter and battery.

ADAPTER (NOT FOR SALE)	
BRAND	SMK
INPUT POWER	100-240Vac, 0.12A, 50-60Hz
OUTPUT POWER	5.4Vdc, 700mA

BATTERY	
BRAND	Fujitsu Limited
MODEL	CA54310-0005
RATING	3.7Vdc, 770mAh

4. Hardware version: V2.0.0.

5. Software version: R11.4.

6. IMEI Code: 35316803*****(*=0-9).

7. The above EUT information was declared by manufacturer and for more detailed features description, please refer to the manufacturer's specifications or User's Manual.



A D T

3.2 DESCRIPTION OF TEST MODES

102 channels are provided to this EUT. Therefore, the low, middle and high channels are chosen for testing.

	CHANNEL	FREQUENCY	TX MODE
LOW	4132	826.4 MHz	WCDMA / HSDPA
MIDDLE	4182	836.4 MHz	WCDMA / HSDPA
HIGH	4233	846.6 MHz	WCDMA / HSDPA

NOTE:

1. Below 1 GHz, the channel 4132, 4182 and 4233 were pre-tested in chamber. The channel 4182 was chosen for final test.
2. Above 1 GHz, the channel 4132, 4182 and 4233 were tested individually.

3.2.1 CONFIGURATION OF SYSTEM UNDER TEST

For Radiated Spurious Emissions Test (Test Mode A)

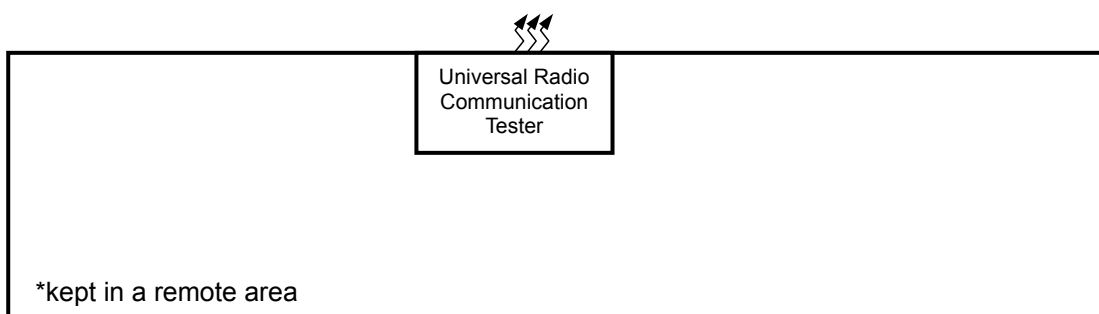
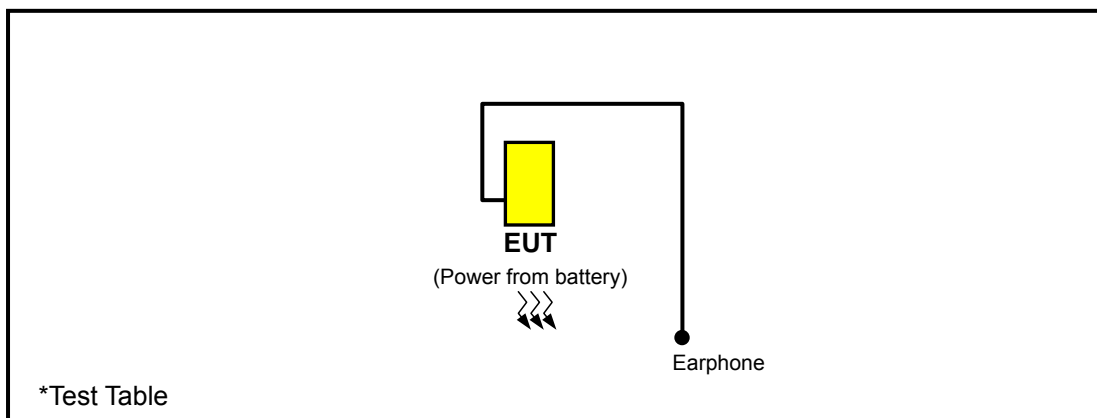

For Conducted Emission Test (Test Mode B)

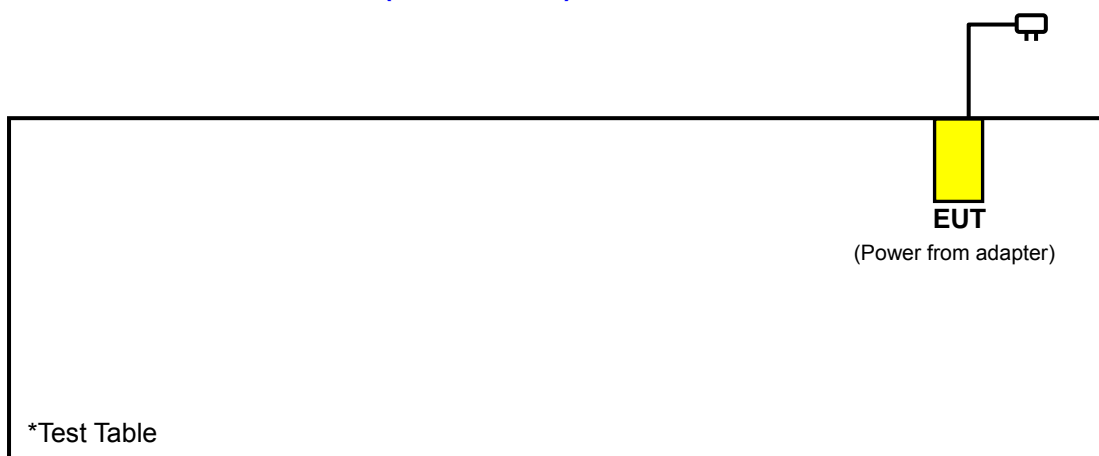

3.2.2 TEST MODE APPLICABILITY AND TESTED CHANNEL DETAIL

EUT CONFIGURE MODE	APPLICABLE TO				DESCRIPTION
	OP	RE<1G	RE≥1G	PLC	
A	√	√	√	NOTE 2	Power from battery
B	-	-	-	√	Power from adapter

Where **RE<1G**: Radiated emission below 1GHz **RE≥1G**: Radiated emission above 1GHz

PLC: Power Line Conducted Emission

NOTE 1: "-" means no effect.

NOTE 2: No need to concern of Conducted Emission due to the EUT is powered by battery.

OUTPUT POWER MEASUREMENT:

- Pre-Scan has been conducted to determine the worst-case mode from all possible combinations between available modulations, data rates, XYZ axis and antenna ports (if EUT with antenna diversity architecture).
- Following channel(s) was (were) selected for the final test as listed below.

EUT CONFIGURE MODE	AVAILABLE CHANNEL	TESTED CHANNEL	MODULATION TECHNOLOGY	AXIS
A	4132 to 4233	4132, 4182, 4233	WCDMA	X, Y, Z
	4132 to 4233	4182	HSDPA	X, Y, Z

RADIATED EMISSION MEASUREMENT (BELOW 1 GHz):

- Pre-Scan has been conducted to determine the worst-case mode from all possible combinations between available modulations, XYZ axis and antenna ports (if EUT with antenna diversity architecture).
- Following channel(s) was (were) selected for the final test as listed below.

EUT CONFIGURE MODE	AVAILABLE CHANNEL	TESTED CHANNEL	MODULATION TECHNOLOGY	AXIS
A	4132 to 4233	4182	WCDMA	X, Y, Z
	4132 to 4233	4182	HSDPA	X, Y, Z



A D T

RADIATED EMISSION MEASUREMENT (ABOVE 1 GHz):

- Pre-Scan has been conducted to determine the worst-case mode from all possible combinations between available modulations, XYZ axis and antenna ports (if EUT with antenna diversity architecture).
- Following channel(s) was (were) selected for the final test as listed below.

EUT CONFIGURE MODE	AVAILABLE CHANNEL	TESTED CHANNEL	MODULATION TECHNOLOGY	AXIS
A	4132 to 4233	4132, 4182, 4233	WCDMA	X, Y, Z
	4132 to 4233	4182	HSDPA	X, Y, Z

POWER LINE CONDUCTED EMISSION TEST:

- Pre-Scan has been conducted to determine the worst-case mode from all possible combinations between available modulations, antenna ports (if EUT with antenna diversity architecture), and packet types.

EUT CONFIGURE MODE	AVAILABLE CHANNEL	TESTED CHANNEL	MODULATION TECHNOLOGY
B	4132 to 4233	4182	WCDMA

TEST CONDITION:

APPLICABLE TO	ENVIRONMENTAL CONDITIONS	INPUT POWER	TESTED BY
OP (Mode A)	22deg. C, 61%RH, 991hPa	3.7Vdc	Mark Liao
RE \geq 1G (Mode A)	22deg. C, 61%RH, 991hPa	3.7Vdc	Mark Liao
RE $<$ 1G (Mode A)	22deg. C, 61%RH, 991hPa	3.7Vdc	Mark Liao
PLC (Mode B)	24deg. C, 66%RH, 1015 hPa	120Vac, 60Hz	Mick Chou



A D T

3.3 GENERAL DESCRIPTION OF APPLIED STANDARDS

The EUT is a RF product. According to the specifications of the manufacturer, it must comply with the requirements of the following standards:

FCC 47 CFR Part 2

FCC 47 CFR Part 22

ANSI C63.4-2003

ANSI/TIA/EIA-603-C 2004

NOTE: All test items have been performed and recorded as per the above standards.

3.4 DESCRIPTION OF SUPPORT UNITS

The EUT has been tested as an independent unit together with other necessary accessories or support units. The following support units or accessories were used to form a representative test configuration during the tests.

NO.	PRODUCT	BRAND	MODEL NO.	SERIAL NO.	FCC ID
1	EARPHONE	NA	NA	NA	NA
2	NJZ-2000 (GSM+WCDMA SIMULATOR)	JRC	NJZ-2000	ET00054	NA
3	ADAPTER	SMK	NA	NA	NA

NO.	SIGNAL CABLE DESCRIPTION OF THE ABOVE SUPPORT UNITS
1	NA
2	NA
3	NA

NOTE:

1. All power cords of the above support units are non shielded (1.8m).
2. Item 3 was supplied from the client for conducted emission test.

4 TEST TYPES AND RESULTS

4.1 OUTPUT POWER MEASUREMENT

4.1.1 LIMITS OF OUTPUT POWER MEASUREMENT

The radiated peak output power shall be according to the specific rule Part 22.913 (a) that “Mobile / Portable station are limited to 7 watts e.r.p”.



A D T

4.1.2 TEST INSTRUMENTS

DESCRIPTION & MANUFACTURER	MODEL NO.	SERIAL NO.	DATE OF CALIBRATION	DUE DATE OF CALIBRATION
Test Receiver ROHDE & SCHWARZ	ESI7	100033	Jul. 06, 2009	Jul. 05, 2010
Spectrum Analyzer ROHDE & SCHWARZ	FSP40	100076	May 26, 2009	May 25, 2010
BILOG Antenna SCHWARZBECK	VULB9168	9168-160	Apr. 27, 2009	Apr. 26, 2010
HORN Antenna SCHWARZBECK	9120D	9120D-209	Jul. 01, 2009	Jun. 30, 2010
HORN Antenna SCHWARZBECK	BBHA 9170	BBHA9170243	Dec. 25, 2009	Dec. 24, 2010
Preamplifier Agilent	8447D	2944A10633	Nov. 10, 2009	Nov. 09, 2010
Preamplifier Agilent	8449B	3008A01964	Nov. 09, 2009	Nov. 08, 2010
RF signal cable HUBER+SUHNNER	SUCOFLEX 104	238141/4	May 13, 2009	May 12, 2010
RF signal cable HUBER+SUHNNER	SUCOFLEX 104	12738/6	May 13, 2009	May 12, 2010
Software ADT.	ADT_Radiated_ V7.6.15.9.2	NA	NA	NA
Antenna Tower inn-co GmbH	MA 4000	013303	NA	NA
Antenna Tower Controller inn-co GmbH	CO2000	017303	NA	NA
Turn Table ADT.	TT100.	TT93021703	NA	NA
Turn Table Controller ADT.	SC100.	SC93021703	NA	NA

- NOTE:**
1. The calibration interval of the above test instruments is 12 months and the calibrations are traceable to NML/ROC and NIST/USA.
 2. The test was performed in HwaYa Chamber 3.
 3. The horn antenna and HP preamplifier (model: 8449B) are used only for the measurement of emission frequency above 1GHz if tested.
 4. The FCC Site Registration No. is 988962.
 5. The IC Site Registration No. is IC 7450F-3.

4.1.3 TEST PROCEDURES

- a. The power was measured with R&S Spectrum Analyzer. All measurements were done at 3 channels, 4132, 4182 and 4233 (WCDMA) (low, middle and high operational frequency range.)
- b. The conducted peak output power used the power splitter via EUT RF power connector between simulation base station and spectrum analyzer. The path loss included the splitter loss, cable loss and 20dB pad loss. The spectrum set RB/VB 5MHz (WCDMA), then read peak power value and record to the test. (All transmitted path loss shall be considered in the test report data.)
- c. Substitution method is used for E.I.R.P measurement. In the semi-anechoic chamber, EUT placed on the 0.8m height of Turn Table, rotated the table around 360 degrees to search the maximum radiation power and receiver antenna shall be rotated vertical and horizontal polarization and moved height from 1m to 4m to find the maximum polar radiated power. The “Read Value” is the spectrum reading the maximum power value.
- d. The substitution horn antenna is substituted for EUT at the same position and signals generator export the CW signal to the substitution antenna via a tx cable . Rotated the Turn Table and moved receiving antenna to find the maximum radiation power. Adjust output power level of S.G to get a Value of spectrum reading equal to “Read Value “ of step c. Record the power level of S.G
- e. $EIRP = \text{Output power level of S.G} - \text{TX cable loss} + \text{Antenna gain of substitution horn.}$
- f. E.R.P power can be calculated form E.I.R.P power by subtracting the gain of dipole,
 $E.R.P \text{ power} = E.I.P.R \text{ power} - 2.15dBi.$

4.1.4 TEST SETUP

EIRP POWER MEASUREMENT:

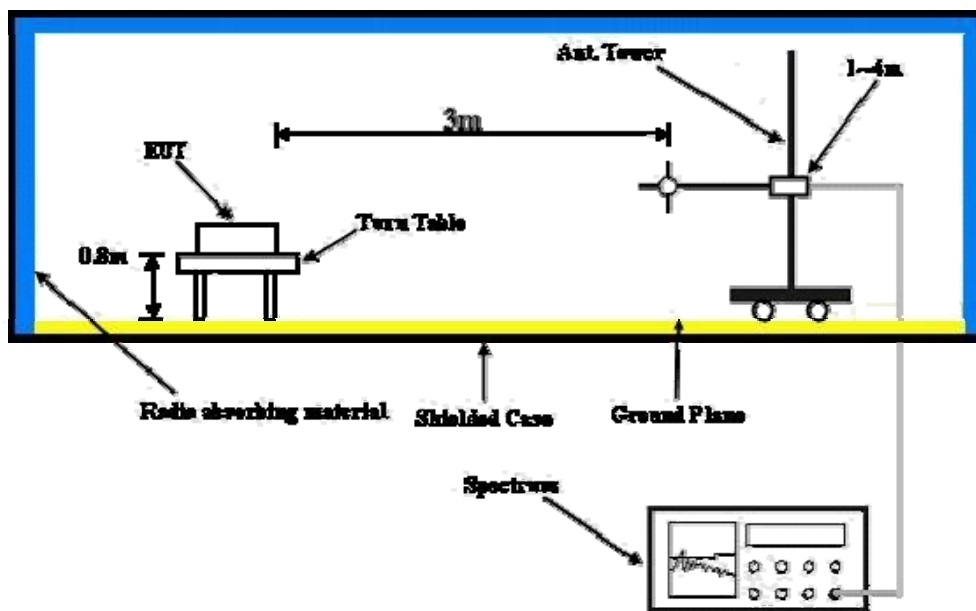

For the actual test configuration, please refer to the attached file (Test Setup Photo).

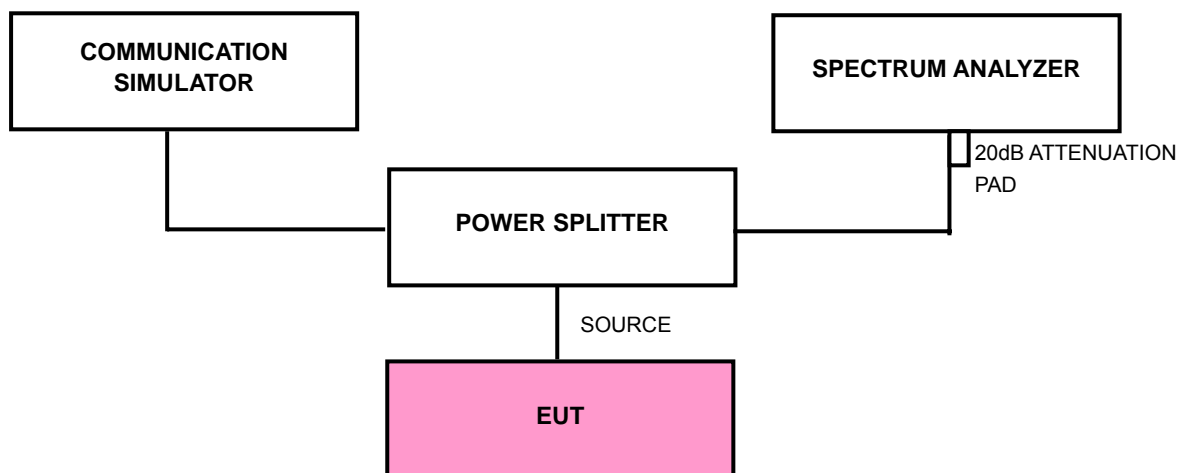
CONDUCTED POWER MEASUREMENT:

For the actual test configuration, please refer to the related item – Photographs of the Test Configuration.

4.1.5 EUT OPERATING CONDITIONS

- a. The EUT makes a phone call to the communication simulator.
- b. The communication simulator station system controlled an EUT to export maximum output power under transmission mode and specific channel frequency.



A D T

4.1.6 TEST RESULTS

FOR WCDMA

X-AXIS

ERP					
CHANNEL NO.	FREQUENCY (MHz)	S.G VALUE (dBm)	CORRECTION FACTOR (dB)	OUTPUT POWER	
				dBm	mW
4132	826.4	29.3	-8.6	20.7	116.1
4182	836.4	30.1	-8.6	21.5	139.6
4233	846.6	29.9	-8.7	21.3	133.4

Y-AXIS

ERP					
CHANNEL NO.	FREQUENCY (MHz)	S.G VALUE (dBm)	CORRECTION FACTOR (dB)	OUTPUT POWER	
				dBm	mW
4132	826.4	29.6	-8.6	21.0	124.5
4182	836.4	30.4	-8.6	21.8	149.6
4233	846.6	30.2	-8.7	21.6	142.9

Z-AXIS

ERP					
CHANNEL NO.	FREQUENCY (MHz)	S.G VALUE (dBm)	CORRECTION FACTOR (dB)	OUTPUT POWER	
				dBm	mW
4132	826.4	30.4	-8.6	21.8	149.6
4182	836.4	30.8	-8.6	22.2	164.1
4233	846.6	30.7	-8.7	22.1	160.3

REMARKS: 1. Peak Output Power (dBm) = S.G Value (dBm) + Correction Factor (dB).

2. Correction Factor (dB) = TX Antenna Gain (dBi) + Cable Loss (dB)



A D T

FOR HSDPA

X-AXIS

ERP					
CHANNEL NO.	FREQUENCY (MHz)	S.G VALUE (dBm)	CORRECTION FACTOR (dB)	OUTPUT POWER	
				dBm	mW
4182	836.4	29.7	-8.6	21.1	127.4

Y-AXIS

ERP					
CHANNEL NO.	FREQUENCY (MHz)	S.G VALUE (dBm)	CORRECTION FACTOR (dB)	OUTPUT POWER	
				dBm	mW
4182	836.4	30.1	-8.6	21.5	139.6

Z-AXIS

ERP					
CHANNEL NO.	FREQUENCY (MHz)	S.G VALUE (dBm)	CORRECTION FACTOR (dB)	OUTPUT POWER	
				dBm	mW
4182	836.4	30.3	-8.6	21.7	146.2

- REMARKS:** 1. Peak Output Power (dBm) = S.G Value (dBm) + Correction Factor (dB).
2. Correction Factor (dB) = TX Antenna Gain (dBi) + Cable Loss (dB)



A D T

4.2 RADIATED EMISSION MEASUREMENT (BELOW 1GHz)

4.2.1 LIMITS OF RADIATED EMISSION MEASUREMENT

In the FCC 24.238(a), On any frequency outside a licensee's frequency block within USPCS spectrum, the power of any emission shall be attenuated below the transmitter power (P) by at least $43 + 10 \log (P)$ dB. The specified minimum attenuation becomes 43dB and the limit of emission equal to -13dBm .

4.2.2 TEST INSTRUMENTS

Same as 4.1.2.

4.2.3 TEST PROCEDURES

- a. Substitution method is used for E.I.R.P measurement. In the semi-anechoic chamber, EUT placed on the 0.8m height of Turn Table, rotated the table around 360 degrees to search the maximum radiation power and receiver antenna shall be rotated vertical and horizontal polarization and moved height from 1m to 4m to find the maximum polar radiated power. The “Read Value” is the spectrum reading the maximum power value.
- b. The substitution horn antenna is substituted for EUT at the same position and signals generator export the CW signal to the substitution antenna via a TX cable. Rotated the Turn Table and moved receiving antenna to find the maximum radiation power. Adjust output power level of S.G to get a Value of spectrum reading equal to “Read Value “ of step a. Record the power level of S.G
- c. $EIRP = \text{Output power level of S.G} - \text{TX cable loss} + \text{Antenna gain of substitution horn.}$
- d. E.R.P power can be calculated form E.I.R.P power by subtracting the gain of dipole,
 $E.R.P \text{ power} = E.I.P.R \text{ power} - 2.15\text{dBi.}$

NOTE: The resolution bandwidth and video bandwidth of test receiver/spectrum analyzer is 1MHz/3MHz.

4.2.4 DEVIATION FROM TEST STANDARD

No deviation

4.2.5 TEST SETUP

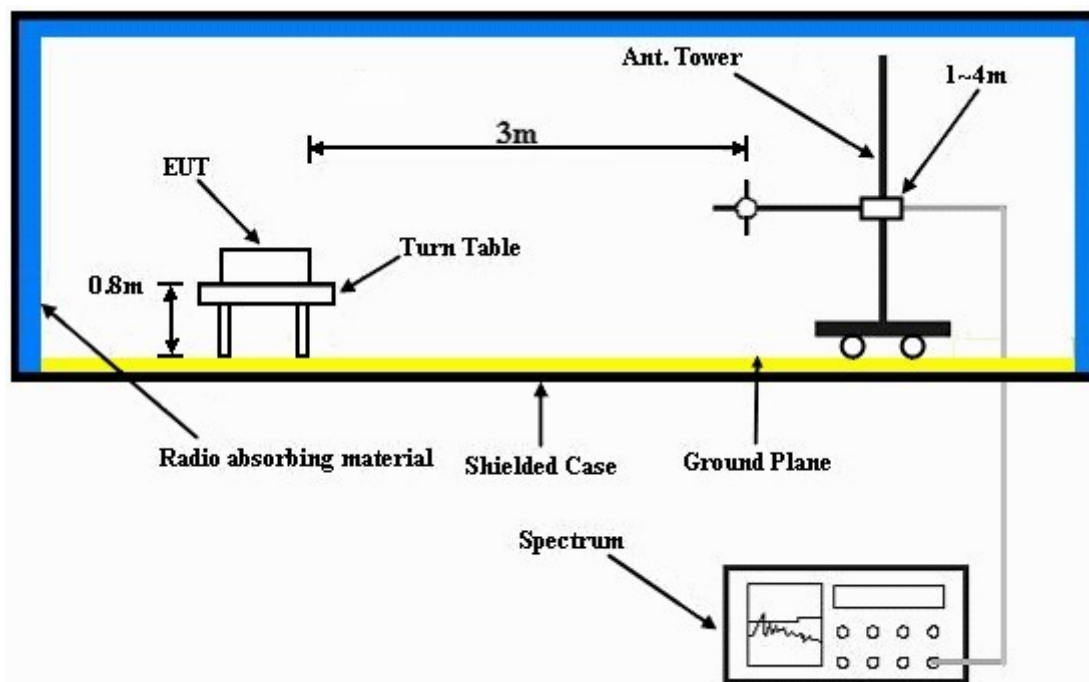

For the actual test configuration, please refer to the attached file (Test Setup Photo).

4.2.6 EUT OPERATING CONDITIONS

- a. The EUT makes a phone call to the communication simulator.
- b. The communication simulator station system controlled an EUT to export maximum output power under transmission mode and specific channel frequency.



A D T

4.2.7 TEST RESULTS

FOR WCDMA

X-AXIS

MODE	TX channel 4182	FREQUENCY RANGE	Below 1000 MHz
INPUT POWER	120Vac, 60 Hz	ENVIRONMENTAL CONDITIONS	22deg. C, 61%RH, 991hPa
TESTED BY	Mark Liao	TEST MODE	X-Axis

ANTENNA POLARITY & TEST DISTANCE: HORIZONTAL AT 3 M						
No.	Freq. (MHz)	Emission Level (dBuV)	Limit (dBm)	S.G Power Value (dBm)	Correction Factor (dB)	Power Value (dBm)
1	146.63	37.8	-13.0	-49.2	-7.7	-56.9
2	224.39	38.1	-13.0	-48.9	-7.7	-56.6
3	259.38	47.4	-13.0	-39.8	-7.7	-47.5
4	333.25	40.1	-13.0	-46.6	-7.8	-54.4
5	465.43	35.5	-13.0	-51.6	-7.8	-59.4
6	718.14	35.3	-13.0	-51.4	-7.9	-59.3
ANTENNA POLARITY & TEST DISTANCE: VERTICAL AT 3 M						
No.	Freq. (MHz)	Emission Level (dBuV)	Limit (dBm)	S.G Power Value (dBm)	Correction Factor (dB)	Power Value (dBm)
1	37.78	42.3	-13.0	-44.4	-7.7	-52.1
2	166.07	37.4	-13.0	-49.9	-7.7	-57.6
3	228.28	44.0	-13.0	-42.6	-7.7	-50.3
4	259.38	37.9	-13.0	-48.8	-7.7	-56.5
5	826.99	51.7	-13.0	-34.9	-7.9	-42.8
6	871.70	48.6	-13.0	-38.5	-7.9	-46.4

NOTE: Power Value (dBum) = S.G Power Value (dBm) + Correction Factor (dB).



A D T

Y-AXIS

MODE	TX channel 4182	FREQUENCY RANGE	Below 1000 MHz
INPUT POWER	120Vac, 60 Hz	ENVIRONMENTAL CONDITIONS	22deg. C, 61%RH, 991hPa
TESTED BY	Mark Liao	TEST MODE	Y-Axis

ANTENNA POLARITY & TEST DISTANCE: HORIZONTAL AT 3 M						
No.	Freq. (MHz)	Emission Level (dBuV)	Limit (dBm)	S.G Power Value (dBm)	Correction Factor (dB)	Power Value (dBm)
1	142.75	39.5	-13.0	-47.3	-7.7	-55.0
2	243.83	43.1	-13.0	-44.0	-7.7	-51.7
3	259.38	46.7	-13.0	-40.4	-7.7	-48.1
4	331.30	39.6	-13.0	-47.3	-7.8	-55.1
5	722.02	35.0	-13.0	-51.3	-7.9	-59.2
6	1000.00	38.6	-12.0	-47.7	-7.9	-55.6

ANTENNA POLARITY & TEST DISTANCE: VERTICAL AT 3 M						
No.	Freq. (MHz)	Emission Level (dBuV)	Limit (dBm)	S.G Power Value (dBm)	Correction Factor (dB)	Power Value (dBm)
1	35.83	43.2	-13.0	-43.6	-7.7	-51.3
2	70.82	34.8	-13.0	-51.6	-7.7	-59.3
3	148.58	39.2	-13.0	-47.9	-7.7	-55.6
4	226.33	48.8	-13.0	-38.1	-7.7	-45.8
5	259.38	35.5	-13.0	-51.5	-7.7	-59.2
6	735.63	34.3	-13.0	-52.0	-7.9	-59.9

NOTE: Power Value (dBum) = S.G Power Value (dBm) + Correction Factor (dB).



A D T

Z-AXIS

MODE	TX channel 4182	FREQUENCY RANGE	Below 1000 MHz
INPUT POWER	120Vac, 60 Hz	ENVIRONMENTAL CONDITIONS	22deg. C, 61%RH, 991hPa
TESTED BY	Mark Liao	TEST MODE	Z-Axis

ANTENNA POLARITY & TEST DISTANCE: HORIZONTAL AT 3 M						
No.	Freq. (MHz)	Emission Level (dBuV)	Limit (dBm)	S.G Power Value (dBm)	Correction Factor (dB)	Power Value (dBm)
1	37.78	32.5	-13.0	-54.5	-7.7	-62.2
2	162.18	33.6	-13.0	-53.1	-7.7	-60.8
3	220.50	36.8	-13.0	-49.9	-7.7	-57.6
4	259.38	43.6	-13.0	-43.0	-7.8	-50.8
5	331.30	36.4	-13.0	-50.1	-7.8	-57.9
6	757.01	33.9	-13.0	-52.5	-7.9	-60.4

ANTENNA POLARITY & TEST DISTANCE: VERTICAL AT 3 M						
No.	Freq. (MHz)	Emission Level (dBuV)	Limit (dBm)	S.G Power Value (dBm)	Correction Factor (dB)	Power Value (dBm)
1	31.94	41.5	-13.0	-45.2	-7.7	-52.9
2	212.73	40.6	-13.0	-46.3	-7.7	-54.0
3	228.28	40.4	-13.0	-46.2	-7.7	-53.9
4	315.75	31.8	-13.0	-55.3	-7.7	-63.0
5	457.66	34.3	-13.0	-52.1	-7.9	-60.0
6	935.85	38.3	-13.0	-48.5	-7.9	-56.4

NOTE: Power Value (dBum) = S.G Power Value (dBm) + Correction Factor (dB).



A D T

FOR HSDPA

X-AXIS

MODE	TX channel 4182	FREQUENCY RANGE	Below 1000 MHz
INPUT POWER	120Vac, 60 Hz	ENVIRONMENTAL CONDITIONS	22deg. C, 61%RH, 991hPa
TESTED BY	Mark Liao	TEST MODE	X-Axis

ANTENNA POLARITY & TEST DISTANCE: HORIZONTAL AT 3 M						
No.	Freq. (MHz)	Emission Level (dBuV)	Limit (dBm)	S.G Power Value (dBm)	Correction Factor (dB)	Power Value (dBm)
1	146.35	37.5	-13.0	-49.4	-7.7	-57.1
2	224.52	38.5	-13.0	-48.6	-7.7	-56.3
3	259.44	47.6	-13.0	-39.5	-7.7	-47.2
4	333.48	40.4	-13.0	-46.5	-7.8	-54.3
5	465.55	35.8	-13.0	-50.8	-7.8	-58.6
6	718.36	35.5	-13.0	-51.3	-7.9	-59.2
ANTENNA POLARITY & TEST DISTANCE: VERTICAL AT 3 M						
No.	Freq. (MHz)	Emission Level (dBuV)	Limit (dBm)	S.G Power Value (dBm)	Correction Factor (dB)	Power Value (dBm)
1	37.86	42.1	-13.0	-44.9	-7.7	-52.6
2	166.24	37.6	-13.0	-49.6	-7.7	-57.3
3	228.36	44.2	-13.0	-42.9	-7.7	-50.6
4	259.66	37.5	-13.0	-49.7	-7.7	-57.4
5	826.81	51.5	-13.0	-35.3	-7.9	-43.2
6	871.84	48.3	-13.0	-38.6	-7.9	-46.5

NOTE: Power Value (dBum) = S.G Power Value (dBm) + Correction Factor (dB).



A D T

Y-AXIS

MODE	TX channel 4182	FREQUENCY RANGE	Below 1000 MHz
INPUT POWER	120Vac, 60 Hz	ENVIRONMENTAL CONDITIONS	22deg. C, 61%RH, 991hPa
TESTED BY	Mark Liao	TEST MODE	Y-Axis

ANTENNA POLARITY & TEST DISTANCE: HORIZONTAL AT 3 M						
No.	Freq. (MHz)	Emission Level (dBuV)	Limit (dBm)	S.G Power Value (dBm)	Correction Factor (dB)	Power Value (dBm)
1	142.61	39.3	-13.0	-47.9	-7.7	-55.6
2	243.61	43.5	-13.0	-43.8	-7.7	-51.5
3	259.46	46.8	-13.0	-40.4	-7.7	-48.1
4	331.50	39.8	-13.0	-47.1	-7.8	-54.9
5	722.24	35.2	-13.0	-51.4	-7.9	-59.3
6	1000.00	38.8	-13.0	-47.9	-7.9	-55.8

ANTENNA POLARITY & TEST DISTANCE: VERTICAL AT 3 M						
No.	Freq. (MHz)	Emission Level (dBuV)	Limit (dBm)	S.G Power Value (dBm)	Correction Factor (dB)	Power Value (dBm)
1	35.61	43.6	-13.0	-43.4	-7.7	-51.1
2	70.59	34.4	-13.0	-52.7	-7.7	-60.4
3	148.26	39.5	-13.0	-47.4	-7.7	-55.1
4	226.45	48.6	-13.0	-38.6	-7.7	-46.3
5	259.62	35.6	-13.0	-51.4	-7.7	-59.1
6	735.84	34.8	-13.0	-51.9	-7.9	-59.8

NOTE: Power Value (dBum) = S.G Power Value (dBm) + Correction Factor (dB).



A D T

Z-AXIS

MODE	TX channel 4182	FREQUENCY RANGE	Below 1000 MHz
INPUT POWER	120Vac, 60 Hz	ENVIRONMENTAL CONDITIONS	22deg. C, 61%RH, 991hPa
TESTED BY	Mark Liao	TEST MODE	Z-Axis

ANTENNA POLARITY & TEST DISTANCE: HORIZONTAL AT 3 M						
No.	Freq. (MHz)	Emission Level (dBuV)	Limit (dBm)	S.G Power Value (dBm)	Correction Factor (dB)	Power Value (dBm)
1	37.82	32.8	-13.0	-54.2	-7.7	-61.9
2	162.25	33.2	-13.0	-53.7	-7.7	-61.4
3	220.81	36.5	-13.0	-50.6	-7.7	-58.3
4	259.48	43.9	-13.0	-43.1	-7.7	-50.8
5	331.50	36.8	-13.0	-50.0	-7.8	-57.8
6	757.24	33.6	-13.0	-53.2	-7.9	-61.1

ANTENNA POLARITY & TEST DISTANCE: VERTICAL AT 3 M						
No.	Freq. (MHz)	Emission Level (dBuV)	Limit (dBm)	S.G Power Value (dBm)	Correction Factor (dB)	Power Value (dBm)
1	31.81	41.8	-13.0	-45.1	-7.7	-52.8
2	212.44	40.3	-13.0	-46.7	-7.7	-54.4
3	228.36	40.6	-13.0	-46.5	-7.7	-54.2
4	315.61	31.5	-13.0	-55.6	-7.8	-63.4
5	457.81	34.5	-13.0	-52.6	-7.8	-60.4
6	935.68	38.6	-13.0	-48.2	-7.9	-56.1

NOTE: Power Value (dBum) = S.G Power Value (dBm) + Correction Factor (dB).

4.3 RADIATED EMISSION MEASUREMENT (ABOVE 1GHz)

4.3.1 LIMITS OF RADIATED EMISSION MEASUREMENT

Same as 4.2.1.

4.3.2 TEST INSTRUMENTS

Same as 4.2.2.

4.3.3 TEST PROCEDURES

Same as 4.2.3.

4.3.4 DEVIATION FROM TEST STANDARD

No deviation

4.3.5 TEST SETUP

Same as 4.2.5.

4.3.6 EUT OPERATING CONDITIONS

Same as 4.2.6.



A D T

4.3.7 TEST RESULTS

FOR WCDMA

X-AXIS

MODE	TX channel 4132	FREQUENCY RANGE	Above 1000 MHz
INPUT POWER	120Vac, 60 Hz	ENVIRONMENTAL CONDITIONS	22deg. C, 61%RH, 991hPa
TESTED BY	Mark Liao	TEST MODE	X-Axis

ANTENNA POLARITY & TEST DISTANCE: HORIZONTAL AT 3 M						
No.	Freq. (MHz)	Emission Level (dBuV)	Limit (dBm)	S.G Power Value (dBm)	Correction Factor (dB)	Power Value (dBm)
1	1652.80	55.6	-13.0	-47.0	7.6	-39.4
2	2479.20	51.8	-13.0	-50.6	8.4	-42.2
3	3305.60	55.3	-13.0	-49.2	9.9	-39.3
4	4132.00	51.9	-13.0	-52.2	9.7	-42.5
ANTENNA POLARITY & TEST DISTANCE: VERTICAL AT 3 M						
No.	Freq. (MHz)	Emission Level (dBuV)	Limit (dBm)	S.G Power Value (dBm)	Correction Factor (dB)	Power Value (dBm)
1	1652.80	61.6	-13.0	-40.3	7.6	-32.7
2	2479.20	54.9	-13.0	-47.9	8.4	-39.5
3	3305.60	51.6	-13.0	-53.1	9.9	-43.2
4	4132.00	51.0	-13.0	-53.5	9.7	-43.8

NOTE: Power Value (dBum) = S.G Power Value (dBm) + Correction Factor (dB).



A D T

MODE	TX channel 4182	FREQUENCY RANGE	Above 1000 MHz
INPUT POWER	120Vac, 60 Hz	ENVIRONMENTAL CONDITIONS	22deg. C, 61%RH, 991hPa
TESTED BY	Mark Liao	TEST MODE	X-Axis

ANTENNA POLARITY & TEST DISTANCE: HORIZONTAL AT 3 M						
No.	Freq. (MHz)	Emission Level (dBuV)	Limit (dBm)	S.G Power Value (dBm)	Correction Factor (dB)	Power Value (dBm)
1	1672.80	58.1	-13.0	-44.2	7.7	-36.5
2	2509.20	55.6	-13.0	-46.9	8.4	-38.5
3	3345.60	53.1	-13.0	-51.4	9.9	-41.5
4	4182.00	49.8	-13.0	-54.6	9.7	-44.9
ANTENNA POLARITY & TEST DISTANCE: VERTICAL AT 3 M						
No.	Freq. (MHz)	Emission Level (dBuV)	Limit (dBm)	S.G Power Value (dBm)	Correction Factor (dB)	Power Value (dBm)
1	1672.80	52.1	-13.0	-50.0	7.7	-42.3
2	2509.20	49.7	-13.0	-53.5	8.4	-45.1
3	3345.60	50.0	-13.0	-54.4	9.9	-44.5
4	4182.00	50.0	-13.0	-54.5	9.7	-44.8

NOTE: Power Value (dBum) = S.G Power Value (dBm) + Correction Factor (dB).



A D T

MODE	TX channel 4233	FREQUENCY RANGE	Above 1000 MHz
INPUT POWER	120Vac, 60 Hz	ENVIRONMENTAL CONDITIONS	22deg. C, 61%RH, 991hPa
TESTED BY	Mark Liao	TEST MODE	X-Axis

ANTENNA POLARITY & TEST DISTANCE: HORIZONTAL AT 3 M

No.	Freq. (MHz)	Emission Level (dBuV)	Limit (dBm)	S.G Power Value (dBm)	Correction Factor (dB)	Power Value (dBm)
1	1693.20	59.1	-13.0	-43.8	7.9	-35.9
2	2539.80	55.1	-13.0	-47.6	8.5	-39.1
3	3386.40	51.8	-13.0	-52.8	9.9	-42.9
4	4233.00	50.6	-13.0	-54.2	9.7	-44.5

ANTENNA POLARITY & TEST DISTANCE: VERTICAL AT 3 M

No.	Freq. (MHz)	Emission Level (dBuV)	Limit (dBm)	S.G Power Value (dBm)	Correction Factor (dB)	Power Value (dBm)
1	1693.20	56.0	-13.0	-46.9	7.9	-39.0
2	2539.80	48.8	-13.0	-54.4	8.5	-45.9
3	3386.40	51.2	-13.0	-53.6	9.9	-43.7
4	4233.00	50.2	-13.0	-53.8	9.7	-44.1

NOTE: Power Value (dBum) = S.G Power Value (dBm) + Correction Factor (dB).



A D T

Y-AXIS

MODE	TX channel 4132	FREQUENCY RANGE	Above 1000 MHz
INPUT POWER	120Vac, 60 Hz	ENVIRONMENTAL CONDITIONS	22deg. C, 61%RH, 991hPa
TESTED BY	Mark Liao	TEST MODE	Y-Axis

ANTENNA POLARITY & TEST DISTANCE: HORIZONTAL AT 3 M						
No.	Freq. (MHz)	Emission Level (dBuV)	Limit (dBm)	S.G Power Value (dBm)	Correction Factor (dB)	Power Value (dBm)
1	1652.80	58.1	-13.0	-62.6	7.6	-55.0
2	2479.20	56.8	-13.0	-60.1	8.4	-51.7
3	3305.60	51.1	-13.0	-58.0	9.9	-48.1
4	4132.00	54.2	-13.0	-64.8	9.7	-55.1
ANTENNA POLARITY & TEST DISTANCE: VERTICAL AT 3 M						
No.	Freq. (MHz)	Emission Level (dBuV)	Limit (dBm)	S.G Power Value (dBm)	Correction Factor (dB)	Power Value (dBm)
1	1652.80	59.4	-13.0	-62.6	7.6	-55.0
2	2479.20	59.7	-13.0	-60.1	8.4	-51.7
3	3305.60	55.3	-13.0	-58.0	9.9	-48.1
4	4132.00	53.5	-13.0	-64.8	9.7	-55.1

NOTE: Power Value (dBum) = S.G Power Value (dBm) + Correction Factor (dB).



A D T

MODE	TX channel 4182	FREQUENCY RANGE	Above 1000 MHz
INPUT POWER	120Vac, 60 Hz	ENVIRONMENTAL CONDITIONS	22deg. C, 61%RH, 991hPa
TESTED BY	Mark Liao	TEST MODE	Y-Axis

ANTENNA POLARITY & TEST DISTANCE: HORIZONTAL AT 3 M

No.	Freq. (MHz)	Emission Level (dBuV)	Limit (dBm)	S.G Power Value (dBm)	Correction Factor (dB)	Power Value (dBm)
1	1672.80	52.1	-13.0	-62.7	7.7	-55.0
2	2509.20	52.9	-13.0	-60.1	8.4	-51.7
3	3345.60	53.5	-13.0	-58.0	9.9	-48.1
4	4182.00	50.5	-13.0	-64.8	9.7	-55.1

ANTENNA POLARITY & TEST DISTANCE: VERTICAL AT 3 M

No.	Freq. (MHz)	Emission Level (dBuV)	Limit (dBm)	S.G Power Value (dBm)	Correction Factor (dB)	Power Value (dBm)
1	1672.80	58.9	-13.0	-62.7	7.7	-55.0
2	2509.20	55.5	-13.0	-60.1	8.4	-51.7
3	3345.60	57.1	-13.0	-58.0	9.9	-48.1
4	4182.00	52.3	-13.0	-64.8	9.7	-55.1

NOTE: Power Value (dBum) = S.G Power Value (dBm) + Correction Factor (dB).



A D T

MODE	TX channel 4233	FREQUENCY RANGE	Above 1000 MHz
INPUT POWER	120Vac, 60 Hz	ENVIRONMENTAL CONDITIONS	22deg. C, 61%RH, 991hPa
TESTED BY	Mark Liao	TEST MODE	Y-Axis

ANTENNA POLARITY & TEST DISTANCE: HORIZONTAL AT 3 M

No.	Freq. (MHz)	Emission Level (dBuV)	Limit (dBm)	S.G Power Value (dBm)	Correction Factor (dB)	Power Value (dBm)
1	1693.20	56.7	-13.0	-62.9	7.9	-55.0
2	2539.80	55.3	-13.0	-60.2	8.5	-51.7
3	3386.40	54.4	-13.0	-58.0	9.9	-48.1
4	4233.00	52.1	-13.0	-64.8	9.7	-55.1

ANTENNA POLARITY & TEST DISTANCE: VERTICAL AT 3 M

No.	Freq. (MHz)	Emission Level (dBuV)	Limit (dBm)	S.G Power Value (dBm)	Correction Factor (dB)	Power Value (dBm)
1	1693.20	61.4	-13.0	-62.9	7.9	-55.0
2	2539.80	56.5	-13.0	-60.2	8.5	-51.7
3	3386.40	57.4	-13.0	-58.0	9.9	-48.1
4	4233.00	52.2	-13.0	-64.8	9.7	-55.1

NOTE: Power Value (dBum) = S.G Power Value (dBm) + Correction Factor (dB).



A D T

Z-AXIS

MODE	TX channel 4132	FREQUENCY RANGE	Above 1000 MHz
INPUT POWER	120Vac, 60 Hz	ENVIRONMENTAL CONDITIONS	22deg. C, 61%RH, 991hPa
TESTED BY	Mark Liao	TEST MODE	Z-Axis

ANTENNA POLARITY & TEST DISTANCE: HORIZONTAL AT 3 M						
No.	Freq. (MHz)	Emission Level (dBuV)	Limit (dBm)	S.G Power Value (dBm)	Correction Factor (dB)	Power Value (dBm)
1	1652.80	55.0	-13.0	-47.2	7.6	-39.6
2	2479.20	59.8	-13.0	-43.0	8.4	-34.6
3	3305.60	56.3	-13.0	-47.9	9.9	-38.0
4	4132.00	52.9	-13.0	-51.6	9.7	-41.9
ANTENNA POLARITY & TEST DISTANCE: VERTICAL AT 3 M						
No.	Freq. (MHz)	Emission Level (dBuV)	Limit (dBm)	S.G Power Value (dBm)	Correction Factor (dB)	Power Value (dBm)
1	1652.80	61.2	-13.0	-40.8	7.6	-33.2
2	2479.20	57.8	-13.0	-45.1	8.4	-36.7
3	3305.60	56.4	-13.0	-48.1	9.9	-38.2
4	4132.00	52.6	-13.0	-51.2	9.7	-41.5

NOTE: Power Value (dBum) = S.G Power Value (dBm) + Correction Factor (dB).



A D T

MODE	TX channel 4182	FREQUENCY RANGE	Above 1000 MHz
INPUT POWER	120Vac, 60 Hz	ENVIRONMENTAL CONDITIONS	22deg. C, 61%RH, 991hPa
TESTED BY	Mark Liao	TEST MODE	Z-Axis

ANTENNA POLARITY & TEST DISTANCE: HORIZONTAL AT 3 M

No.	Freq. (MHz)	Emission Level (dBuV)	Limit (dBm)	S.G Power Value (dBm)	Correction Factor (dB)	Power Value (dBm)
1	1672.80	55.6	-13.0	-46.8	7.7	-39.1
2	2509.20	51.8	-13.0	-51.4	8.4	-43.0
3	3345.60	5.3	-13.0	-99.4	9.9	-89.5
4	4182.00	51.9	-13.0	-52.2	9.7	-42.5

ANTENNA POLARITY & TEST DISTANCE: VERTICAL AT 3 M

No.	Freq. (MHz)	Emission Level (dBuV)	Limit (dBm)	S.G Power Value (dBm)	Correction Factor (dB)	Power Value (dBm)
1	1672.80	61.6	-13.0	-40.4	7.7	-32.7
2	2509.20	54.9	-13.0	-48.1	8.4	-39.7
3	3345.60	51.6	-13.0	-52.5	9.9	-42.6
4	4182.00	51.0	-13.0	-53.5	9.7	-43.8

NOTE: Power Value (dBum) = S.G Power Value (dBm) + Correction Factor (dB).



A D T

MODE	TX channel 4233	FREQUENCY RANGE	Above 1000 MHz
INPUT POWER	120Vac, 60 Hz	ENVIRONMENTAL CONDITIONS	22deg. C, 61%RH, 991hPa
TESTED BY	Mark Liao	TEST MODE	Z-Axis

ANTENNA POLARITY & TEST DISTANCE: HORIZONTAL AT 3 M						
No.	Freq. (MHz)	Emission Level (dBuV)	Limit (dBm)	S.G Power Value (dBm)	Correction Factor (dB)	Power Value (dBm)
1	1693.20	57.7	-13.0	-44.9	7.9	-37.0
2	2539.80	49.4	-13.0	-53.8	8.5	-45.3
3	3386.40	57.4	-13.0	-47.0	9.9	-37.1
4	4233.00	51.8	-13.0	-52.4	9.7	-42.7
ANTENNA POLARITY & TEST DISTANCE: VERTICAL AT 3 M						
No.	Freq. (MHz)	Emission Level (dBuV)	Limit (dBm)	S.G Power Value (dBm)	Correction Factor (dB)	Power Value (dBm)
1	1693.20	58.1	-13.0	-44.6	7.9	-36.7
2	2539.80	54.7	-13.0	-48.3	8.5	-39.8
3	3386.40	54.1	-13.0	-50.0	9.9	-40.1
4	4233.00	51.1	-13.0	-53.4	9.7	-43.7

NOTE: Power Value (dBum) = S.G Power Value (dBm) + Correction Factor (dB).



A D T

FOR HSDPA

X-AXIS

MODE	TX channel 4182	FREQUENCY RANGE	Above 1000 MHz
INPUT POWER	120Vac, 60 Hz	ENVIRONMENTAL CONDITIONS	22deg. C, 61%RH, 991hPa
TESTED BY	Mark Liao	TEST MODE	X-Axis

ANTENNA POLARITY & TEST DISTANCE: HORIZONTAL AT 3 M						
No.	Freq. (MHz)	Emission Level (dBuV)	Limit (dBm)	S.G Power Value (dBm)	Correction Factor (dB)	Power Value (dBm)
1	1672.80	58.3	-13.0	-43.8	7.7	-36.1
2	2509.20	55.1	-13.0	-48.0	8.4	-39.6
3	3345.60	53.3	-13.0	-51.4	9.9	-41.5
4	4182.00	50.1	-13.0	-54.2	9.7	-44.5
ANTENNA POLARITY & TEST DISTANCE: VERTICAL AT 3 M						
No.	Freq. (MHz)	Emission Level (dBuV)	Limit (dBm)	S.G Power Value (dBm)	Correction Factor (dB)	Power Value (dBm)
1	1672.80	51.9	-13.0	-50.3	7.7	-42.6
2	2509.20	49.7	-13.0	-53.7	8.4	-45.3
3	3345.60	50.2	-13.0	-54.3	9.9	-44.4
4	4182.00	49.9	-13.0	-54.7	9.7	-45.0

NOTE: Power Value (dBum) = S.G Power Value (dBm) + Correction Factor (dB).



A D T

Y-AXIS

MODE	TX channel 4182	FREQUENCY RANGE	Above 1000 MHz
INPUT POWER	120Vac, 60 Hz	ENVIRONMENTAL CONDITIONS	22deg. C, 61%RH, 991hPa
TESTED BY	Mark Liao	TEST MODE	Y-Axis

ANTENNA POLARITY & TEST DISTANCE: HORIZONTAL AT 3 M						
No.	Freq. (MHz)	Emission Level (dBuV)	Limit (dBm)	S.G Power Value (dBm)	Correction Factor (dB)	Power Value (dBm)
1	1672.80	51.9	-13.0	-50.0	7.7	-42.3
2	2509.20	52.7	-13.0	-50.2	8.4	-41.8
3	3345.60	53.5	-13.0	-50.6	9.9	-40.7
4	4182.00	50.1	-13.0	-54.2	9.7	-44.5
ANTENNA POLARITY & TEST DISTANCE: VERTICAL AT 3 M						
No.	Freq. (MHz)	Emission Level (dBuV)	Limit (dBm)	S.G Power Value (dBm)	Correction Factor (dB)	Power Value (dBm)
1	1672.80	58.3	-13.0	-43.8	7.7	-36.1
2	2509.20	55.1	-13.0	-48.0	8.4	-39.6
3	3345.60	56.7	-13.0	-47.2	9.9	-37.3
4	4182.00	52.0	-13.0	-52.3	9.7	-42.6

NOTE: Power Value (dBum) = S.G Power Value (dBm) + Correction Factor (dB).



A D T

Z-AXIS

MODE	TX channel 4182	FREQUENCY RANGE	Above 1000 MHz
INPUT POWER	120Vac, 60 Hz	ENVIRONMENTAL CONDITIONS	22deg. C, 61%RH, 991hPa
TESTED BY	Mark Liao	TEST MODE	Z-Axis

ANTENNA POLARITY & TEST DISTANCE: HORIZONTAL AT 3 M						
No.	Freq. (MHz)	Emission Level (dBuV)	Limit (dBm)	S.G Power Value (dBm)	Correction Factor (dB)	Power Value (dBm)
1	1672.80	55.1	-13.0	-46.8	7.7	-39.1
2	2509.20	51.4	-13.0	-51.4	8.4	-43.0
3	3345.60	55.0	-13.0	-49.2	9.9	-39.3
4	4182.00	51.7	-13.0	-52.8	9.7	-43.1
ANTENNA POLARITY & TEST DISTANCE: VERTICAL AT 3 M						
No.	Freq. (MHz)	Emission Level (dBuV)	Limit (dBm)	S.G Power Value (dBm)	Correction Factor (dB)	Power Value (dBm)
1	1672.80	61.1	-13.0	-40.8	7.7	-33.1
2	2509.20	54.5	-13.0	-48.8	8.4	-40.4
3	3345.60	51.4	-13.0	-52.7	9.9	-42.8
4	4182.00	50.8	-13.0	-53.8	9.7	-44.1

NOTE: Power Value (dBum) = S.G Power Value (dBm) + Correction Factor (dB).



A D T

4.4 CONDUCTED EMISSION MEASUREMENT

4.4.1 LIMITS OF CONDUCTED EMISSION MEASUREMENT

FREQUENCY OF EMISSION (MHz)	CONDUCTED LIMIT (dB μ V)	
	Quasi-peak	Average
0.15-0.5	66 to 56	56 to 46
0.5-5	56	46
5-30	60	50

- NOTE:**
1. The lower limit shall apply at the transition frequencies.
 2. The limit decreases in line with the logarithm of the frequency in the range of 0.15 to 0.50 MHz.
 3. All emanations from a class A/B digital device or system, including any network of conductors and apparatus connected thereto, shall not exceed the level of field strengths specified above.

4.4.2 TEST INSTRUMENTS

DESCRIPTION & MANUFACTURER	MODEL NO.	SERIAL NO.	DATE OF CALIBRATION	DUE DATE OF CALIBRATION
Test Receiver ROHDE & SCHWARZ	ESCS30	100291	Dec. 16, 2009	Dec. 15, 2010
RF signal cable Woken	5D-FB	Cable-HYC01-01	Nov. 12, 2009	Nov. 11, 2010
LISN ROHDE & SCHWARZ	ESH3-Z5	100312	Jun. 18, 2009	Jun. 17, 2010
LISN SCHWARZBECK	NNBL 8226-2	8226-142	Jun. 03, 2009	Jun. 02, 2010
Software ADT	ADT_Cond_ V7.3.7	NA	NA	NA

- NOTE:**
1. The calibration interval of the above test instruments is 12 months and the calibrations are traceable to NML/ROC and NIST/USA.
 2. The test was performed in HwaYa Shielded Room 1.
 3. The VCCI Site Registration No. is C-2040.



A D T

4.4.3 TEST PROCEDURES

- a. The EUT was placed 0.4 meters from the conducting wall of the shielded room with EUT being connected to the power mains through a line impedance stabilization network (LISN). Other support units were connected to the power mains through another LISN. The two LISNs provide 50 ohm/ 50uH of coupling impedance for the measuring instrument.
- b. Both lines of the power mains connected to the EUT were checked for maximum conducted interference.
- c. The frequency range from 150kHz to 30MHz was searched. Emission levels under (Limit - 20dB) was not recorded.

NOTE: All modes of operation were investigated and the worst-case emissions are reported.

4.4.4 DEVIATION FROM TEST STANDARD

No deviation.

4.4.5 TEST SETUP

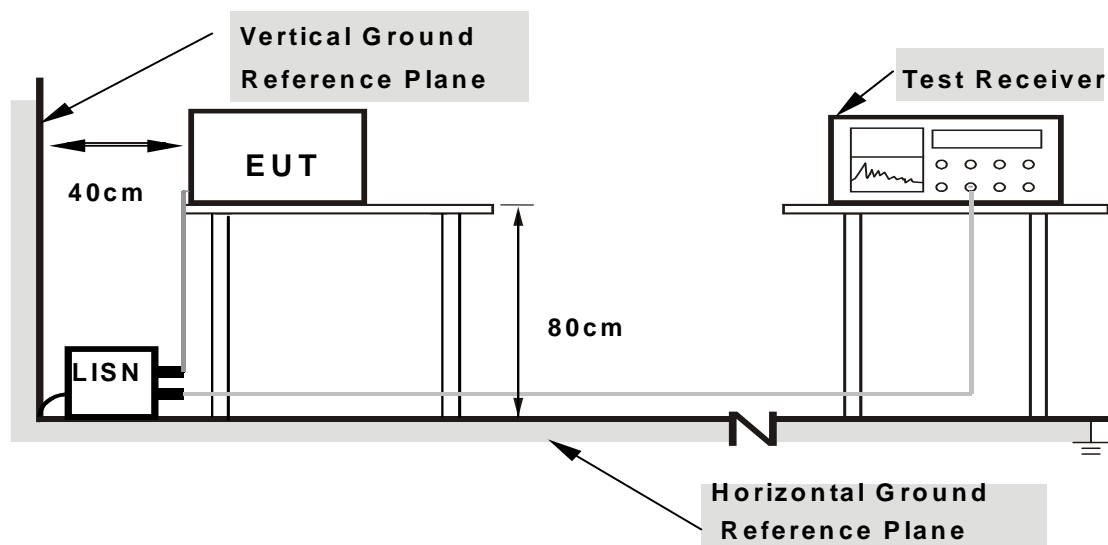

Note: 1.Support units were connected to second LISN.

2.Both of LISNs (AMN) are 80 cm from EUT and at least 80 from other units and other metal planes

For the actual test configuration, please refer to the attached file (Test Setup Photo).

4.4.6 EUT OPERATING CONDITIONS

Set the EUT under transmitting condition.

4.4.7 TEST RESULTS

CONDUCTED WORST CASE DATA: WCDMA

PHASE	Line 1	6dB BANDWIDTH	9kHz
--------------	--------	----------------------	------

No	Freq. [MHz]	Corr. Factor (dB)	Reading Value		Emission Level		Limit		Margin	
			[dB (uV)]		[dB (uV)]		[dB (uV)]		(dB)	
			Q.P.	AV.	Q.P.	AV.	Q.P.	AV.	Q.P.	AV.
1	0.170	0.10	36.65	-	36.75	-	64.98	54.98	-28.23	-
2	0.599	0.14	35.37	-	35.51	-	56.00	46.00	-20.49	-
3	0.783	0.15	35.79	-	35.94	-	56.00	46.00	-20.06	-
4	1.391	0.20	34.08	-	34.28	-	56.00	46.00	-21.72	-
5	2.914	0.29	36.71	-	37.00	-	56.00	46.00	-19.00	-
6	24.359	1.29	32.16	-	33.45	-	60.00	50.00	-26.55	-

- REMARKS:**
1. Q.P. and AV. are abbreviations of quasi-peak and average individually.
 2. "-": The Quasi-peak reading value also meets average limit and measurement with the average detector is unnecessary.
 3. The emission levels of other frequencies were very low against the limit.
 4. Margin value = Emission level - Limit value
 5. Correction factor = Insertion loss + Cable loss
 6. Emission Level = Correction Factor + Reading Value.

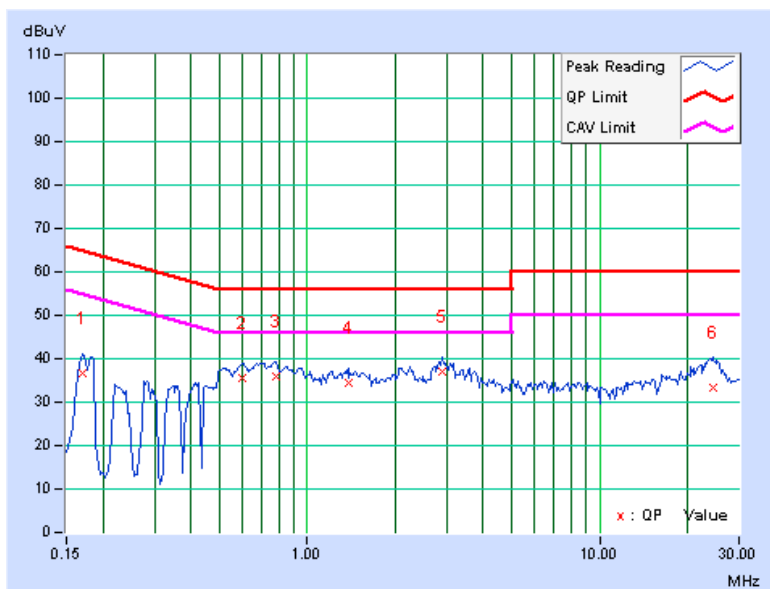



A D T

PHASE	Line 2	6dB BANDWIDTH	9kHz
-------	--------	---------------	------

No	Freq. [MHz]	Corr. Factor (dB)	Reading Value		Emission Level		Limit		Margin	
			[dB (uV)]		[dB (uV)]		[dB (uV)]		(dB)	
			Q.P.	AV.	Q.P.	AV.	Q.P.	AV.	Q.P.	AV.
1	0.173	0.12	38.26	-	38.38	-	64.79	54.79	-26.41	-
2	0.287	0.13	33.57	-	33.70	-	60.62	50.62	-26.92	-
3	0.408	0.14	28.97	-	29.11	-	57.69	47.69	-28.58	-
4	0.982	0.18	29.23	-	29.41	-	56.00	46.00	-26.59	-
5	3.094	0.29	34.97	-	35.26	-	56.00	46.00	-20.74	-
6	24.828	0.96	30.87	-	31.83	-	60.00	50.00	-28.17	-

- REMARKS:**
1. Q.P. and AV. are abbreviations of quasi-peak and average individually.
 2. "-": The Quasi-peak reading value also meets average limit and measurement with the average detector is unnecessary.
 3. The emission levels of other frequencies were very low against the limit.
 4. Margin value = Emission level - Limit value
 5. Correction factor = Insertion loss + Cable loss
 6. Emission Level = Correction Factor + Reading Value.

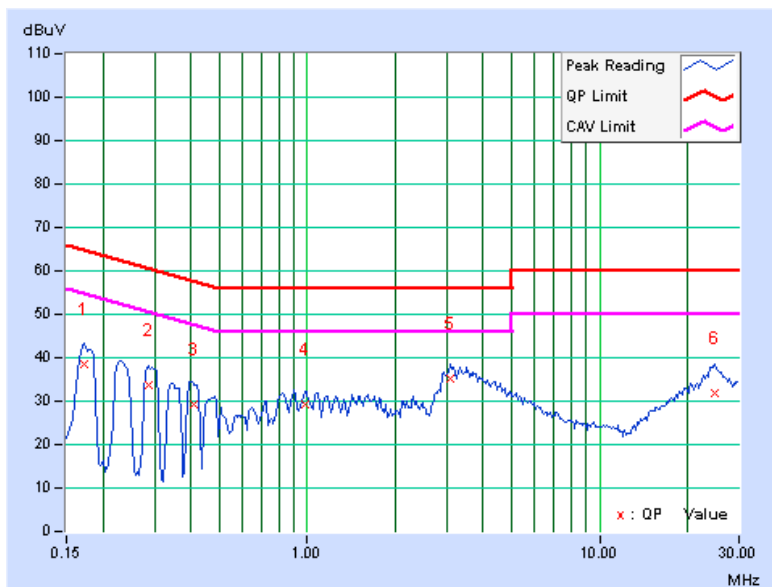



A D T

5 PHOTOGRAPHS OF THE TEST CONFIGURATION

Please refer to the attached file (Test Setup Photo).



6 INFORMATION ON THE TESTING LABORATORIES

We, Bureau Veritas Consumer Products Services (H.K.) Ltd., Taoyuan Branch, were founded in 1988 to provide our best service in EMC, Radio, Telecom and Safety consultation. Our laboratories are accredited and approved according to ISO/IEC 17025.

Copies of accreditation certificates of our laboratories obtained from approval agencies can be downloaded from our web site: www.adt.com.tw/index.5/phtml. If you have any comments, please feel free to contact us at the following:

Linko EMC/RF Lab:

Tel: 886-2-26052180

Fax: 886-2-26051924

Hsin Chu EMC/RF Lab:

Tel: 886-3-5935343

Fax: 886-3-5935342

Hwa Ya EMC/RF/Safety/Telecom Lab:

Tel: 886-3-3183232

Fax: 886-3-3185050

Web Site: www.adt.com.tw

The address and road map of all our labs can be found in our web site also.



A D T

7 APPENDIX A – MODIFICATIONS RECORDERS FOR ENGINEERING CHANGES TO THE EUT BY THE LAB

No any modifications are made to the EUT by the lab during the test.

---END---