

FCC Test Report

Report No.: RF170713C02-4

FCC ID: VQK-F02K

Test Model: F-02K

Received Date: Jul. 13, 2017

Test Date: Sep. 07, 2017 ~ Sep. 13, 2017

Issued Date: Sep. 22, 2017

Applicant: FUJITSU CONNECTED TECHNOLOGIES Ltd.

Address: 1-1, Kamikodanaka 4-chome, Nakahara-ku, Kawasaki 211-8588, Japan

Issued By: Bureau Veritas Consumer Products Services (H.K.) Ltd., Taoyuan Branch

Lab Address: No. 47-2, 14th Ling, Chia Pau Vil., Lin Kou Dist., New Taipei City, Taiwan (R.O.C)

Test Location (1): No. 19, Hwa Ya 2nd Rd, Wen Hwa Tsuen, Kwei Shan Hsiang, Taoyuan Hsien 333, Taiwan, R.O.C.

Test Location (2): No.215, Sec. 3, Beixin Rd., Xindian Dist., New Taipei City 231, Taiwan, R.O.C



This report is for your exclusive use. Any copying or replication of this report to or for any other person or entity, or use of our name or trademark, is permitted only with our prior written permission. This report sets forth our findings solely with respect to the test samples identified herein. The results set forth in this report are not indicative or representative of the quality or characteristics of the lot from which a test sample was taken or any similar or identical product unless specifically and expressly noted. Our report includes all of the tests requested by you and the results thereof based upon the information that you provided to us. You have 60 days from date of issuance of this report to notify us of any material error or omission caused by our negligence, provided, however, that such notice shall be in writing and shall specifically address the issue you wish to raise. A failure to raise such issue within the prescribed time shall constitute your unqualified acceptance of the completeness of this report, the tests conducted and the correctness of the report contents. Unless specific mention, the uncertainty of measurement has been explicitly taken into account to declare the compliance or non-compliance to the specification. The report must not be used by the client to claim product certification, approval, or endorsement by TAF or any government agencies.

Table of Contents

Release Control Record	4
1 Certificate of Conformity	5
2 Summary of Test Results	6
2.1 Measurement Uncertainty.....	6
2.2 Modification Record	6
3 General Information	7
3.1 General Description of EUT	7
3.2 Description of Test Modes.....	8
3.2.1 Test Mode Applicability and Tested Channel Detail.....	10
3.3 Duty Cycle of Test Signal	12
3.4 Description of Support Units	13
3.4.1 Configuration of System under Test	13
3.5 General Description of Applied Standards.....	13
4 Test Types and Results	14
4.1 Radiated Emission and Bandedge Measurement	14
4.1.1 Limits of Radiated Emission and Bandedge Measurement	14
4.1.2 Limits of Unwanted Emission Out of the Restricted Bands	15
4.1.3 Test Instruments	16
4.1.4 Test Procedures.....	17
4.1.5 Deviation from Test Standard	17
4.1.6 Test Set Up	18
4.1.7 EUT Operating Conditions.....	19
4.1.8 Test Results	20
4.2 Conducted Emission Measurement.....	52
4.2.1 Limits of Conducted Emission Measurement	52
4.2.2 Test Instruments	52
4.2.3 Test Procedures.....	53
4.2.4 Deviation from Test Standard	53
4.2.5 Test Setup.....	53
4.2.6 EUT Operating Conditions.....	53
4.2.7 Test Results	54
4.3 Transmit Power Measurement.....	56
4.3.1 Limits of Transmit Power Measurement	56
4.3.2 Test Setup.....	56
4.3.3 Test Instruments	57
4.3.4 Test Procedure	57
4.3.5 Deviation from Test Standard	57
4.3.6 EUT Operating Conditions.....	57
4.3.7 Test Result	58
4.4 Occupied Bandwidth Measurement.....	64
4.4.1 Test Setup.....	64
4.4.2 Test Instruments	64
4.4.3 Test Procedure	64
4.4.4 Test Results	65
4.5 Peak Power Spectral Density Measurement	68
4.5.1 Limits of Peak Power Spectral Density Measurement	68
4.5.2 Test Setup.....	68
4.5.3 Test Instruments	68
4.5.4 Test Procedures.....	68
4.5.5 Deviation from Test Standard	69
4.5.6 EUT Operating Conditions.....	69
4.5.7 Test Results	70
4.6 Frequency Stability	73

4.6.1	Limit of Frequency Stability Measurement	73
4.6.2	Test Setup	73
4.6.3	Test Instruments	73
4.6.4	Test Procedure	73
4.6.5	Deviation from Test Standard	73
4.6.6	EUT Operating Condition	73
4.6.7	Test Results	74
5	Pictures of Test Arrangements.....	75
	Appendix – Information on the Testing Laboratories	76

Release Control Record

Issue No.	Description	Date Issued
RF170713C02-4	Original Release	Sep. 22, 2017

1 Certificate of Conformity

Product: Tablet PC

Brand: FUJITSU

Test Model: F-02K

Sample Status: Identical Prototype

Applicant: FUJITSU CONNECTED TECHNOLOGIES Ltd.

Test Date: Sep. 07, 2017 ~ Sep. 13, 2017

Standards: 47 CFR FCC Part 15, Subpart E (Section 15.407)
ANSI C63.10:2013

The above equipment has been tested by **Bureau Veritas Consumer Products Services (H.K.) Ltd., Taoyuan Branch**, and found compliance with the requirement of the above standards. The test record, data evaluation & Equipment Under Test (EUT) configurations represented herein are true and accurate accounts of the measurements of the sample's EMC characteristics under the conditions specified in this report.

Prepared by : Evonne Liu , **Date:** Sep. 22, 2017
Evonne Liu / Specialist

Approved by : David Huang , **Date:** Sep. 22, 2017
David Huang / Project Engineer

2 Summary of Test Results

47 CFR FCC Part 15, Subpart E (Section 15.407)			
FCC Clause	Test Item	Result	Remarks
15.407(b)(6)	AC Power Conducted Emissions	Pass	Meet the requirement of limit. Minimum passing margin is -13.06 dB at 0.57969 MHz.
15.407(b) (1/2/3/4(i/ii)/6)	Radiated Emissions & Band Edge Measurement	Pass	Meet the requirement of limit. Minimum passing margin is -4.07 dB at 11000 MHz.
15.407(a)(1/2/3)	Max Average Transmit Power	Pass	Meet the requirement of limit.
---	Occupied Bandwidth Measurement	-	Reference only
15.407(a)(1/2/3)	Peak Power Spectral Density	Pass	Meet the requirement of limit.
15.407(e)	6 dB Bandwidth	Pass	Meet the requirement of limit. (U-NII-3 Band only)
15.407(g)	Frequency Stability	Pass	Meet the requirement of limit.
15.203	Antenna Requirement	Pass	No antenna connector is used.

*For U-NII-3 band compliance with rule part 15.407(b)(4)(i), the OOB test plots were recorded in Annex A.

2.1 Measurement Uncertainty

Where relevant, the following measurement uncertainty levels have been estimated for tests performed on the EUT as specified in CISPR 16-4-2:

Measurement	Frequency	Expanded Uncertainty (k=2) (±)
Conducted Emissions at mains ports	150 kHz ~ 30 MHz	2.44 dB
Radiated Emissions up to 1 GHz	30 MHz ~ 200 MHz	2.0153 dB
	200 MHz ~ 1000 MHz	2.0224 dB
Radiated Emissions above 1 GHz	1 GHz ~ 18 GHz	1.0121 dB
	18 GHz ~ 40 GHz	1.1508 dB

2.2 Modification Record

There were no modifications required for compliance.

3 General Information

3.1 General Description of EUT

Product	Tablet PC
Brand	FUJITSU
Test Model	F-02K
Status of EUT	Identical Prototype
Power Supply Rating	5.0 Vdc (adapter or host equipment) 3.8 Vdc (Li-ion battery)
Modulation Type	256QAM, 64QAM, 16QAM, QPSK, BPSK
Modulation Technology	OFDM
Transfer Rate	802.11a: 54.0/ 48.0/ 36.0/ 24.0/ 18.0/ 12.0/ 9.0/ 6.0 Mbps 802.11n: up to MCS7 802.11ac: up to V9
Operating Frequency	5180 ~ 5240 MHz, 5260 ~ 5320 MHz, 5500 ~ 5700 MHz,
Number of Channel	5180 ~ 5240 MHz: 4 for 802.11a, 802.11n (HT20) 2 for 802.11n (HT40) 1 for 802.11ac (VHT80) 5260 ~ 5320 MHz: 4 for 802.11a, 802.11n (HT20) 2 for 802.11n (HT40) 1 for 802.11ac (VHT80) 5500 ~ 5700 MHz: 11 for 802.11a, 802.11n (HT20) 5 for 802.11n (HT40) 2 for 802.11ac (VHT80)
Output Power	6.734 mW for 5180 ~ 5240 MHz 6.375 mW for 5260 ~ 5320 MHz 6.729 mW for 5500 ~ 5700 MHz
Antenna Type	$\lambda/4$ Monopole antenna with -0.1 dBi gain(Chain 0) / -3.5 dBi gain(Chain 1)
Antenna Connector	N/A
Accessory Device	Refer to Note as below
Data Cable Supplied	Refer to Note as below

Note:

- The EUT incorporates a MIMO function. Physically, the EUT provides two completed transmitters and two receivers.

Modulation Mode	Tx Function
802.11a	1TX
802.11n (HT20)	2TX
802.11n (HT40)	2TX
802.11ac (VHT80)	2TX

* The modulation and bandwidth are similar for 802.11n mode for HT20 / HT40 and 802.11ac mode for HT20 / HT40, therefore investigated worst case to representative mode in test report. (Final test mode refer section 3.2.1)

2. The EUT contains following accessory devices.

Product	Brand	Model	Description
Adapter	NTT docomo	AC Adapter 06	I/P: 100-240 Vac, 50/60 Hz, 0.8 A O/P: 5 Vdc, 3 A
Battery	FUJITSU CONNECTED TECHNOLOGIES Ltd	CA54310-0068	3.8 Vdc, 6000 mAh
Stylus pen	Wacom Co., Ltd.	ESP-101-35-5	--
Stand (no charging function)	FUJITSU CONNECTED TECHNOLOGIES Ltd.	JBC3348-010010	--

3. The above EUT information is declared by manufacturer and for more detailed features description, please refer to the manufacturer's specifications or user's manual.

3.2 Description of Test Modes

For 5180 ~ 5240 MHz

4 channels are provided for 802.11a, 802.11n (HT20):

Channel	Frequency (MHz)	Channel	Frequency (MHz)
36	5180	44	5220
40	5200	48	5240

2 channels are provided for 802.11n (HT40):

Channel	Frequency (MHz)	Channel	Frequency (MHz)
38	5190	46	5230

1 channel is provided for 802.11ac (VHT80):

Channel	Frequency (MHz)
42	5210

For 5260 ~ 5320 MHz

4 channels are provided for 802.11a, 802.11n (HT20):

Channel	Frequency (MHz)	Channel	Frequency (MHz)
52	5260	60	5300
56	5280	64	5320

2 channels are provided for 802.11n (HT40):

Channel	Frequency (MHz)	Channel	Frequency (MHz)
54	5270	62	5310

1 channel is provided for 802.11ac (VHT80):

Channel	Frequency (MHz)
58	5290

For 5500 ~ 5700 MHz

11 channels are provided for 802.11a, 802.11n (HT20):

Channel	Frequency (MHz)	Channel	Frequency (MHz)
100	5500	124	5620
104	5520	128	5640
108	5540	132	5660
112	5560	136	5680
116	5580	140	5700
120	5600		

5 channels are provided for 802.11n (HT40):

Channel	Frequency (MHz)	Channel	Frequency (MHz)
102	5510	126	5630
110	5550	134	5670
118	5590		

2 channels are provided for 802.11ac (VHT80):

Channel	Frequency (MHz)	Channel	Frequency (MHz)
106	5530	122	5610

3.2.1 Test Mode Applicability and Tested Channel Detail

EUT Configure Mode	Applicable To				Description
	RE \geq 1G	RE $<$ 1G	PLC	APCM	
-	√	√	√	√	-

Where **RE \geq 1G**: Radiated Emission above 1 GHz **RE $<$ 1G**: Radiated Emission below 1 GHz
PLC: Power Line Conducted Emission **APCM**: Antenna Port Conducted Measurement

Note:

1. The EUT had been pre-tested on the positioned of each 3 axis. The worst case was found when positioned on **X-plane**.
2. "-" means no effect.

Radiated Emission Test (Above 1 GHz):

- Pre-Scan has been conducted to determine the worst-case mode from all possible combinations between available modulations, data rates and antenna ports (if EUT with antenna diversity architecture).
- Following channel(s) was (were) selected for the final test as listed below.

EUT Configure Mode	Frequency Band (MHz)	Mode	Available Channel	Tested Channel	Modulation Technology	Modulation Type	Data Rate (Mbps)
-	5180-5240	802.11a	36 to 48	36, 44, 48	OFDM	BPSK	6.0
-		802.11n (HT20)	36 to 48	36, 44, 48	OFDM	BPSK	MCS0
-		802.11n (HT40)	38 to 46	38, 46	OFDM	BPSK	MCS0
-		802.11ac (VHT80)	42	42	OFDM	BPSK	MCS0
-	5260-5320	802.11a	52 to 64	52, 60, 64	OFDM	BPSK	6.0
-		802.11n (HT20)	52 to 64	52, 60, 64	OFDM	BPSK	MCS0
-		802.11n (HT40)	54 to 62	54, 62	OFDM	BPSK	MCS0
-		802.11ac (VHT80)	58	58	OFDM	BPSK	MCS0
-	5500-5700	802.11a	100 to 140	100, 116, 140	OFDM	BPSK	6.0
-		802.11n (HT20)	100 to 140	100, 116, 140	OFDM	BPSK	MCS0
-		802.11n (HT40)	102 to 134	102, 110, 134	OFDM	BPSK	MCS0
-		802.11ac (VHT80)	106 to 122	106, 122	OFDM	BPSK	MCS0

Radiated Emission Test (Below 1 GHz):

- Pre-Scan has been conducted to determine the worst-case mode from all possible combinations between available modulations, data rates and antenna ports (if EUT with antenna diversity architecture).
- Following channel(s) was (were) selected for the final test as listed below.

EUT Configure Mode	Frequency Band (MHz)	Mode	Available Channel	Tested Channel	Modulation Technology	Modulation Type	Data Rate (Mbps)
-	5180-5240	802.11ac (VHT80)	42	42	OFDM	BPSK	MCS0
-	5260-5320	802.11a	52 to 64	64	OFDM	BPSK	6.0
-	5500-5700	802.11a	100 to 140	100	OFDM	BPSK	6.0

Power Line Conducted Emission Test:

- Pre-Scan has been conducted to determine the worst-case mode from all possible combinations between available modulations, data rates and antenna ports (if EUT with antenna diversity architecture).
- Following channel(s) was (were) selected for the final test as listed below.

EUT Configure Mode	Frequency Band (MHz)	Mode	Available Channel	Tested Channel	Modulation Technology	Modulation Type	Data Rate (Mbps)
-	5500-5700	802.11a	100 to 140	100	OFDM	BPSK	6.0

Antenna Port Conducted Measurement:

- This item includes all test value of each mode, but only includes spectrum plot of worst value of each mode.
- Pre-Scan has been conducted to determine the worst-case mode from all possible combinations between available modulations, data rates and antenna ports (if EUT with antenna diversity architecture).
- Following channel(s) was (were) selected for the final test as listed below.

EUT Configure Mode	Frequency Band (MHz)	Mode	Available Channel	Tested Channel	Modulation Technology	Modulation Type	Data Rate (Mbps)
-	5180-5240	802.11a	36 to 48	36, 44, 48	OFDM	BPSK	6.0
-		802.11n (HT20)	36 to 48	36, 44, 48	OFDM	BPSK	MCS0
-		802.11n (HT40)	38 to 46	38, 46	OFDM	BPSK	MCS0
-		802.11ac (VHT80)	42	42	OFDM	BPSK	MCS0
-	5260-5320	802.11a	52 to 64	52, 60, 64	OFDM	BPSK	6.0
-		802.11n (HT20)	52 to 64	52, 60, 64	OFDM	BPSK	MCS0
-		802.11n (HT40)	54 to 62	54, 62	OFDM	BPSK	MCS0
-		802.11ac (VHT80)	58	58	OFDM	BPSK	MCS0
-	5500-5700	802.11a	100 to 140	100, 116, 140	OFDM	BPSK	6.0
-		802.11n (HT20)	100 to 140	100, 116, 140	OFDM	BPSK	MCS0
-		802.11n (HT40)	102 to 134	102, 110, 134	OFDM	BPSK	MCS0
-		802.11ac (VHT80)	106 to 122	106, 122	OFDM	BPSK	MCS0

Test Condition:

Applicable To	Environmental Conditions	Input Power	Tested by
RE \geq 1G	25 deg. C, 65 % RH	120 Vac, 60 Hz	Karl Lee
RE<1G	25 deg. C, 65 % RH	120 Vac, 60 Hz	Karl Lee
PLC	25 deg. C, 65 % RH	120 Vac, 60 Hz	Getaz Yang
APCM	25 deg. C, 65 % RH	3.8 Vdc	Anson Lin

3.3 Duty Cycle of Test Signal

MODULATION TYPE: BPSK

Duty cycle of test signal is < 98 %, duty factor is required.

802.11a: Duty cycle = $2.062/2.192 = 0.941$, Duty factor = $10 * \log(1/0.941) = 0.27$

802.11n (HT20): Duty cycle = $1.922/2.054 = 0.936$, Duty factor = $10 * \log(1/0.936) = 0.29$

802.11n (HT40): Duty cycle = $0.946/1.084 = 0.873$, Duty factor = $10 * \log(1/0.873) = 0.59$

802.11ac (VHT80): Duty cycle = $0.461/0.576 = 0.80$, Duty factor = $10 * \log(1/0.80) = 0.97$

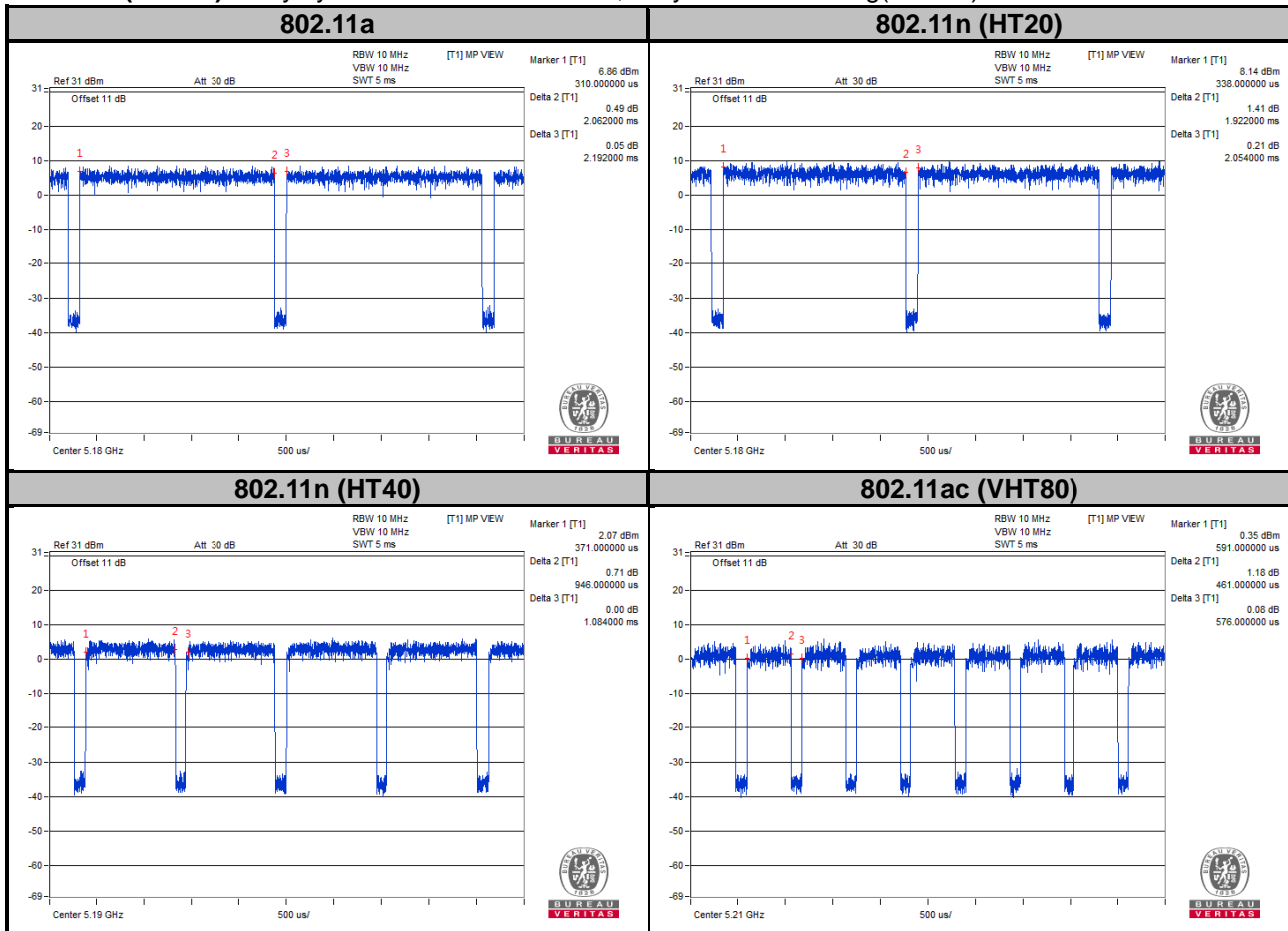

3.4 Description of Support Units

The EUT has been tested as an independent unit together with other necessary accessories or support units.

3.4.1 Configuration of System under Test

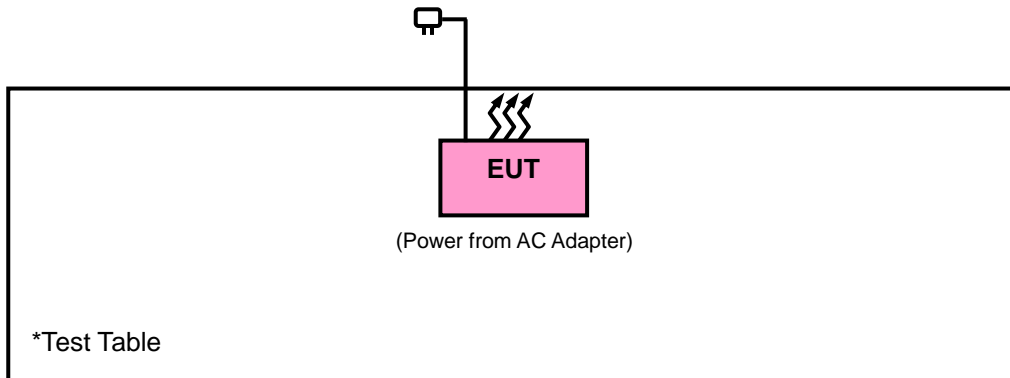

3.5 General Description of Applied Standards

The EUT is a RF Product. According to the specifications of the manufacturer, it must comply with the requirements of the following standards:

FCC Part 15, Subpart E (15.407)

789033 D02 General UNII Test Procedures New Rules v01r04

644545 D01 Guidance for IEEE 802 11ac v01r02

662911 D01 Multiple Transmitter Output v02r01

ANSI C63.10-2013

All test items have been performed and recorded as per the above standards.

4 Test Types and Results

4.1 Radiated Emission and Bandedge Measurement

4.1.1 Limits of Radiated Emission and Bandedge Measurement

Radiated emissions which fall in the restricted bands must comply with the radiated emission limits specified as below table. Other emissions shall be at least 20 dB below the highest level of the desired power:

Frequencies (MHz)	Field Strength (microvolts/meter)	Measurement Distance (meters)
0.009 ~ 0.490	2400/F (kHz)	300
0.490 ~ 1.705	24000/F (kHz)	30
1.705 ~ 30.0	30	30
30 ~ 88	100	3
88 ~ 216	150	3
216 ~ 960	200	3
Above 960	500	3

Note:

1. The lower limit shall apply at the transition frequencies.
2. Emission level (dBuV/m) = 20 log Emission level (uV/m).
3. For frequencies above 1000 MHz, the field strength limits are based on average detector, however, the peak field strength of any emission shall not exceed the maximum permitted average limits, specified above by more than 20 dB under any condition of modulation.

4.1.2 Limits of Unwanted Emission Out of the Restricted Bands

Applicable To		Limit	
789033 D02 General UNII Test Procedures New Rules v01r04		Field Strength at 3 m	
		PK: 74 (dBµV/m)	AV: 54 (dBµV/m)
Frequency Band	Applicable To	EIRP Limit	Equivalent Field Strength at 3 m
5150~5250 MHz	15.407(b)(1)	PK: -27 (dBm/MHz)	PK: 68.2 (dBµV/m)
5250~5350 MHz	15.407(b)(2)		
5470~5725 MHz	15.407(b)(3)		
5725~5850 MHz	15.407(b)(4)(i)	PK:-27 (dBm/MHz) ^{*1} PK:10 (dBm/MHz) ^{*2} PK:15.6 (dBm/MHz) ^{*3} PK:27 (dBm/MHz) ^{*4}	PK: 68.2 (dBµV/m) ^{*1} PK:105.2 (dBµV/m) ^{*2} PK: 110.8 (dBµV/m) ^{*3} PK:122.2 (dBµV/m) ^{*4}
	15.407(b)(4)(ii)	Emission limits in section 15.247(d)	
^{*1} beyond 75 MHz or more above of the band edge. ^{*2} below the band edge increasing linearly to 10 dBm/MHz at 25 MHz above. ^{*3} below the band edge increasing linearly to a level of 15.6 dBm/MHz at 5 MHz above. ^{*4} from 5 MHz above or below the band edge increasing linearly to a level of 27 dBm/MHz at the band edge.			

Note:

The following formula is used to convert the equipment isotropic radiated power (eirp) to field strength:

$$E = \frac{1000000\sqrt{30P}}{3} \mu\text{V/m, where } P \text{ is the eirp (Watts).}$$

4.1.3 Test Instruments

Description & Manufacturer	Model No.	Serial No.	Date of Calibration	Due Date of Calibration
Test Receiver Agilent Technologies	N9038A	MY52260177	Jul. 05, 2017	Jul. 04, 2018
Spectrum Analyzer ROHDE & SCHWARZ	FSU43	101261	Dec. 13, 2016	Dec. 12, 2017
BILOG Antenna SCHWARZBECK	VULB9168	9168-472	Dec. 16, 2016	Dec. 15, 2017
HORN Antenna ETS-Lindgren	3117	00143293	Dec. 29, 2016	Dec. 28, 2017
HORN Antenna SCHWARZBECK	BBHA 9170	9170-480	Dec. 14, 2016	Dec. 13, 2017
Fixed Attenuator Mini-Circuits	MDCS18N-10	MDCS18N-10-01	Apr. 17, 2017	Apr. 16, 2018
Bluetooth Tester	CBT	100980	Jun. 28, 2017	Jun. 27, 2019
Loop Antenna	HLA 6121	45745	May 19, 2017	May 18, 2018
Preamplifier Agilent	310N	187226	Jun. 23, 2017	Jun. 22, 2018
Preamplifier Agilent	83017A	MY39501357	Jun. 23, 2017	Jun. 22, 2018
Power Meter Anritsu	ML2495A	1232002	Sep. 08, 2016	Sep. 07, 2017
Power Sensor Anritsu	MA2411B	1207325	Sep. 08, 2016	Sep. 07, 2017
RF signal cable ETS-LINDGREN	5D-FB	Cable-CH1-01(R FC-SMS-100-SM S-120+RFC-SMS -100-SMS-400)	Jun. 23, 2017	Jun. 22, 2018
RF signal cable ETS-LINDGREN	8D-FB	Cable-CH1-02(R FC-SMS-100-SM S-24)	Jun. 23, 2017	Jun. 22, 2018
Software BV ADT	E3 8.130425b	NA	NA	NA
Antenna Tower MF	NA	NA	NA	NA
Turn Table MF	NA	NA	NA	NA
Antenna Tower & Turn Table Controller MF	MF-7802	NA	NA	NA

- Note: 1. The calibration interval of the above test instruments is 12 / 24 months and the calibrations are traceable to NML/ROC and NIST/USA.
2. The test was performed in HsinTien Chamber 1.
3. The horn antenna and preamplifier (model: 83017A) are used only for the measurement of emission frequency above 1 GHz if tested.
4. The FCC Designation Number is TW0011. The number will be varied with the Lab location and scope as attached.
5. The IC Site Registration No. is IC7450I-1.

4.1.4 Test Procedures

- a. The EUT was placed on the top of a rotating table 0.8 meters (for below 1 GHz) / 1.5 meters (for above 1 GHz) above the ground at 3 meter chamber room for test. The table was rotated 360 degrees to determine the position of the highest radiation.
- b. The EUT was set 3 meters away from the interference-receiving antenna, which was mounted on the top of a variable-height antenna tower.
- c. The height of antenna is varied from one meter to four meters above the ground to determine the maximum value of the field strength. Both horizontal and vertical polarizations of the antenna are set to make the measurement.
- d. For each suspected emission, the EUT was arranged to its worst case and then the antenna was tuned to heights from 1 meter to 4 meters and the rotatable table was turned from 0 degrees to 360 degrees to find the maximum reading.
- e. The test-receiver system was set to quasi-peak detect function and specified bandwidth with maximum hold mode when the test frequency is below 1 GHz.
- f. The test-receiver system was set to peak and average detected function and specified bandwidth with maximum hold mode when the test frequency is above 1 GHz. If the peak reading value also meets average limit, measurement with the average detector is unnecessary.

Note:

1. The resolution bandwidth and video bandwidth of test receiver/spectrum analyzer is 120 kHz & 360 kHz for Quasi-peak detection (QP) at frequency below 1 GHz.
2. The resolution bandwidth of test receiver/spectrum analyzer is 1 MHz and the video bandwidth is 3 MHz for Peak detection (PK) at frequency above 1 GHz.
3. The resolution bandwidth of test receiver/spectrum analyzer is 1 MHz and the video bandwidth is 1/T for Average (Duty cycle < 98 %) detection at frequency above 1 GHz.
4. The resolution bandwidth of test receiver/spectrum analyzer is 1 MHz and the video bandwidth is 10 Hz (Duty cycle \geq 98 %) for Average detection (AV) at frequency above 1 GHz.
5. All modes of operation were investigated and the worst-case emissions are reported.

4.1.5 Deviation from Test Standard

No deviation.

4.1.6 Test Set Up

<Radiated emission below 30MHz>

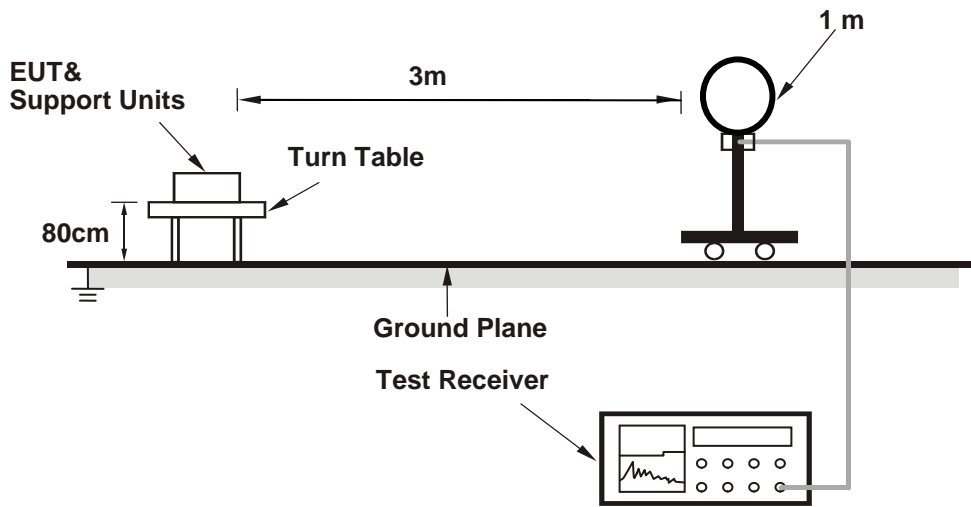

<Frequency Range below 1 GHz>

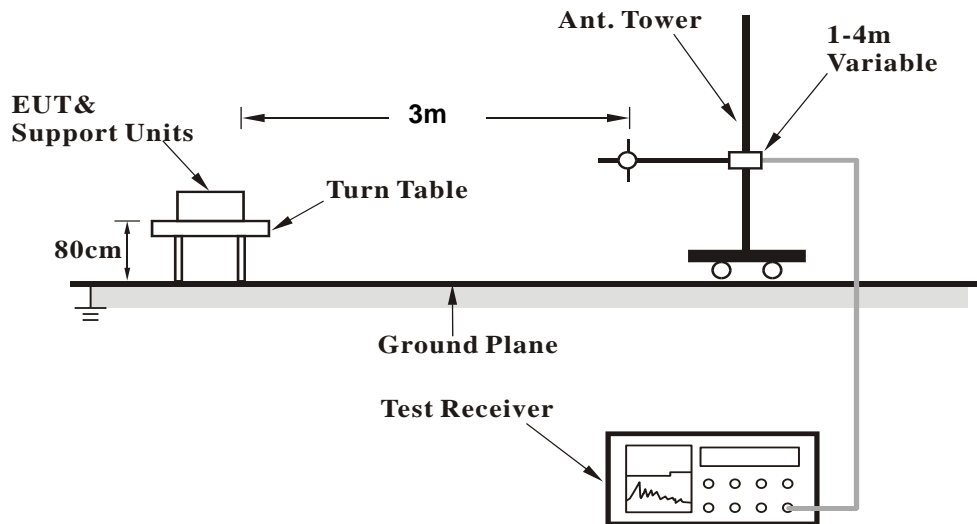

<Frequency Range above 1 GHz>

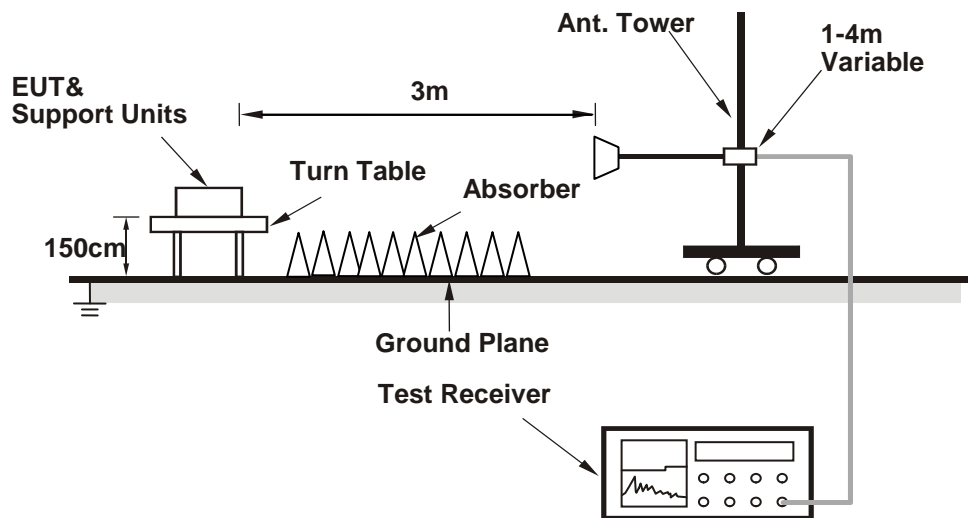

For the actual test configuration, please refer to the attached file (Test Setup Photo).

4.1.7 EUT Operating Conditions

- a. Placed the EUT on a testing table.
- b. Use the software to control the EUT under transmission condition continuously at specific channel frequency.

4.1.8 Test Results
Above 1 GHz Data :
802.11a

EUT Test Condition		Measurement Detail	
Channel	Channel 36	Frequency Range	1 GHz ~ 40 GHz
Input Power	120 Vac, 60 Hz	Detector Function	Peak (PK) Average (AV)
Environmental Conditions	25 deg. C, 65 % RH	Tested By	Karl Lee

Antenna Polarity & Test Distance: Horizontal at 3 m										
Frequency (MHz)	Emission Level (dBuV/m)	Read Level (dBuV)	Limit (dBuV/m)	Margin (dB)	Antenna Factor (dB/m)	Cable Loss (dB)	Preamp Factor (dB)	Antenna Height (cm)	Table Angle (Degree)	Remark
5123.9	43.15	34.93	54	-10.85	34.11	8.1	33.99	212	73	Average
5123.9	53.14	44.92	74	-20.86	34.11	8.1	33.99	212	73	Peak
5180	91.19	82.88			34.15	8.16	34	212	73	Average
5180	98	89.69			34.15	8.16	34	212	73	Peak
*10360	55.78	41.48	68.2	-12.42	37.12	12.3	35.12	196	27	Peak

Antenna Polarity & Test Distance: Vertical at 3 m										
Frequency (MHz)	Emission Level (dBuV/m)	Read Level (dBuV)	Limit (dBuV/m)	Margin (dB)	Antenna Factor (dB/m)	Cable Loss (dB)	Preamp Factor (dB)	Antenna Height (cm)	Table Angle (Degree)	Remark
5107.55	42.81	34.61	54	-11.19	34.09	8.1	33.99	278	310	Average
5107.55	53.07	44.87	74	-20.93	34.09	8.1	33.99	278	310	Peak
5180	82.68	74.37			34.15	8.16	34	278	310	Average
5180	89.62	81.31			34.15	8.16	34	278	310	Peak
*10360	55.7	41.4	68.2	-12.5	37.12	12.3	35.12	176	131	Peak

Remarks:

- Emission Level = Read Level + Antenna Factor + Cable Loss - Preamp Factor
 Margin value = Emission level – Limit value
- 5180 MHz: Fundamental Frequency
- *: Out of Restricted Band

EUT Test Condition		Measurement Detail	
Channel	Channel 44	Frequency Range	1 GHz ~ 40 GHz
Input Power	120 Vac, 60 Hz	Detector Function	Peak (PK) Average (AV)
Environmental Conditions	25 deg. C, 65 % RH	Tested By	Karl Lee

Antenna Polarity & Test Distance: Horizontal at 3 m										
Frequency (MHz)	Emission Level (dBuV/m)	Read Level (dBuV)	Limit (dBuV/m)	Margin (dB)	Antenna Factor (dB/m)	Cable Loss (dB)	Preamp Factor (dB)	Antenna Height (cm)	Table Angle (Degree)	Remark
5137.4	42.72	34.47	54	-11.28	34.11	8.13	33.99	212	73	Average
5137.4	53.36	45.11	74	-20.64	34.11	8.13	33.99	212	73	Peak
5220	91.58	83.19			34.17	8.22	34	212	73	Average
5220	98.56	90.17			34.17	8.22	34	212	73	Peak
5444.49	43.05	34.26	54	-10.95	34.35	8.48	34.04	212	73	Average
5444.49	53.87	45.08	74	-20.13	34.35	8.48	34.04	212	73	Peak

Antenna Polarity & Test Distance: Vertical at 3 m										
Frequency (MHz)	Emission Level (dBuV/m)	Read Level (dBuV)	Limit (dBuV/m)	Margin (dB)	Antenna Factor (dB/m)	Cable Loss (dB)	Preamp Factor (dB)	Antenna Height (cm)	Table Angle (Degree)	Remark
5102.3	42.72	34.56	54	-11.28	34.08	8.07	33.99	278	310	Average
5102.3	53.4	45.24	74	-20.6	34.08	8.07	33.99	278	310	Peak
5220	82.97	74.58			34.17	8.22	34	278	310	Average
5220	90.01	81.62			34.17	8.22	34	278	310	Peak
5351.87	43.14	34.51	54	-10.86	34.28	8.38	34.03	278	310	Average
5351.87	54.25	45.62	74	-19.75	34.28	8.38	34.03	278	310	Peak

Remarks:

- Emission Level = Read Level + Antenna Factor + Cable Loss - Preamp Factor
Margin value = Emission level – Limit value
- 5220 MHz: Fundamental Frequency
- *: Out of Restricted Band

EUT Test Condition		Measurement Detail	
Channel	Channel 48	Frequency Range	1 GHz ~ 40 GHz
Input Power	120 Vac, 60 Hz	Detector Function	Peak (PK) Average (AV)
Environmental Conditions	25 deg. C, 65 % RH	Tested By	Karl Lee

Antenna Polarity & Test Distance: Horizontal at 3 m										
Frequency (MHz)	Emission Level (dBuV/m)	Read Level (dBuV)	Limit (dBuV/m)	Margin (dB)	Antenna Factor (dB/m)	Cable Loss (dB)	Preamp Factor (dB)	Antenna Height (cm)	Table Angle (Degree)	Remark
5240	91.1	82.66			34.19	8.26	34.01	212	73	Average
5240	98.15	89.71			34.19	8.26	34.01	212	73	Peak
5424.69	43.15	34.38	54	-10.85	34.33	8.48	34.04	212	73	Average
5424.69	53.66	44.89	74	-20.34	34.33	8.48	34.04	212	73	Peak
*10480	56.25	41.74	68.2	-11.95	37.19	12.53	35.21	157	120	Peak

Antenna Polarity & Test Distance: Vertical at 3 m										
Frequency (MHz)	Emission Level (dBuV/m)	Read Level (dBuV)	Limit (dBuV/m)	Margin (dB)	Antenna Factor (dB/m)	Cable Loss (dB)	Preamp Factor (dB)	Antenna Height (cm)	Table Angle (Degree)	Remark
5240	82.71	74.27			34.19	8.26	34.01	278	310	Average
5240	89.99	81.55			34.19	8.26	34.01	278	310	Peak
5452.63	42.85	34.03	54	-11.15	34.36	8.51	34.05	278	310	Average
5452.63	53.31	44.49	74	-20.69	34.36	8.51	34.05	278	310	Peak
*10480	56.15	41.64	68.2	-12.05	37.19	12.53	35.21	127	166	Peak

Remarks:

- Emission Level = Read Level + Antenna Factor + Cable Loss - Preamp Factor
Margin value = Emission level – Limit value
- 5240 MHz: Fundamental Frequency
- *: Out of Restricted Band

EUT Test Condition		Measurement Detail	
Channel	Channel 52	Frequency Range	1 GHz ~ 40 GHz
Input Power	120 Vac, 60 Hz	Detector Function	Peak (PK) Average (AV)
Environmental Conditions	25 deg. C, 65 % RH	Tested By	Karl Lee

Antenna Polarity & Test Distance: Horizontal at 3 m										
Frequency (MHz)	Emission Level (dBuV/m)	Read Level (dBuV)	Limit (dBuV/m)	Margin (dB)	Antenna Factor (dB/m)	Cable Loss (dB)	Preamp Factor (dB)	Antenna Height (cm)	Table Angle (Degree)	Remark
5110.25	42.85	34.65	54	-11.15	34.09	8.1	33.99	210	62	Average
5110.25	54.6	46.4	74	-19.4	34.09	8.1	33.99	210	62	Peak
5260	92.57	84.11			34.21	8.26	34.01	210	62	Average
5260	99.88	91.42			34.21	8.26	34.01	210	62	Peak
*10520	57.38	42.79	68.2	-10.82	37.21	12.61	35.23	157	265	Peak

Antenna Polarity & Test Distance: Vertical at 3 m										
Frequency (MHz)	Emission Level (dBuV/m)	Read Level (dBuV)	Limit (dBuV/m)	Margin (dB)	Antenna Factor (dB/m)	Cable Loss (dB)	Preamp Factor (dB)	Antenna Height (cm)	Table Angle (Degree)	Remark
5139.2	42.82	34.57	54	-11.18	34.11	8.13	33.99	258	322	Average
5139.2	52.82	44.57	74	-21.18	34.11	8.13	33.99	258	322	Peak
5260	85.14	76.68			34.21	8.26	34.01	258	322	Average
5260	92.1	83.64			34.21	8.26	34.01	258	322	Peak
*10520	57.15	42.56	68.2	-11.05	37.21	12.61	35.23	129	320	Peak

Remarks:

- Emission Level = Read Level + Antenna Factor + Cable Loss - Preamp Factor
Margin value = Emission level – Limit value
- 5260 MHz: Fundamental Frequency
- *: Out of Restricted Band

EUT Test Condition		Measurement Detail	
Channel	Channel 60	Frequency Range	1 GHz ~ 40 GHz
Input Power	120 Vac, 60 Hz	Detector Function	Peak (PK) Average (AV)
Environmental Conditions	25 deg. C, 65 % RH	Tested By	Karl Lee

Antenna Polarity & Test Distance: Horizontal at 3 m										
Frequency (MHz)	Emission Level (dBuV/m)	Read Level (dBuV)	Limit (dBuV/m)	Margin (dB)	Antenna Factor (dB/m)	Cable Loss (dB)	Preamp Factor (dB)	Antenna Height (cm)	Table Angle (Degree)	Remark
5121.65	42.63	34.43	54	-11.37	34.09	8.1	33.99	210	62	Average
5121.65	53.22	45.02	74	-20.78	34.09	8.1	33.99	210	62	Peak
5300	92.5	83.96			34.24	8.32	34.02	210	62	Average
5300	99.29	90.75			34.24	8.32	34.02	210	62	Peak
5362.65	43.39	34.75	54	-10.61	34.29	8.38	34.03	210	62	Average
5362.65	54.49	45.85	74	-19.51	34.29	8.38	34.03	210	62	Peak
Antenna Polarity & Test Distance: Vertical at 3 m										
Frequency (MHz)	Emission Level (dBuV/m)	Read Level (dBuV)	Limit (dBuV/m)	Margin (dB)	Antenna Factor (dB/m)	Cable Loss (dB)	Preamp Factor (dB)	Antenna Height (cm)	Table Angle (Degree)	Remark
5053.85	42.71	34.65	54	-11.29	34.04	8	33.98	258	322	Average
5053.85	53.3	45.24	74	-20.7	34.04	8	33.98	258	322	Peak
5300	84.74	76.2			34.24	8.32	34.02	258	322	Average
5300	91.63	83.09			34.24	8.32	34.02	258	322	Peak
5430.52	42.92	34.13	54	-11.08	34.35	8.48	34.04	258	322	Average
5430.52	54.19	45.4	74	-19.81	34.35	8.48	34.04	258	322	Peak

Remarks:

- Emission Level = Read Level + Antenna Factor + Cable Loss - Preamp Factor
Margin value = Emission level – Limit value
- 5300 MHz: Fundamental Frequency
- *: Out of Restricted Band

EUT Test Condition		Measurement Detail	
Channel	Channel 64	Frequency Range	1 GHz ~ 40 GHz
Input Power	120 Vac, 60 Hz	Detector Function	Peak (PK) Average (AV)
Environmental Conditions	25 deg. C, 65 % RH	Tested By	Karl Lee

Antenna Polarity & Test Distance: Horizontal at 3 m										
Frequency (MHz)	Emission Level (dBuV/m)	Read Level (dBuV)	Limit (dBuV/m)	Margin (dB)	Antenna Factor (dB/m)	Cable Loss (dB)	Preamp Factor (dB)	Antenna Height (cm)	Table Angle (Degree)	Remark
5320	92.86	84.28			34.25	8.35	34.02	210	62	Average
5320	99.44	90.86			34.25	8.35	34.02	210	62	Peak
5389.16	43.31	34.63	54	-10.69	34.31	8.41	34.04	210	62	Average
5389.16	54.68	46	74	-19.32	34.31	8.41	34.04	210	62	Peak
10640	49.33	34.6	54	-4.67	37.31	12.71	35.29	196	235	Average
10640	58.26	43.53	74	-15.74	37.31	12.71	35.29	196	235	Peak

Antenna Polarity & Test Distance: Vertical at 3 m										
Frequency (MHz)	Emission Level (dBuV/m)	Read Level (dBuV)	Limit (dBuV/m)	Margin (dB)	Antenna Factor (dB/m)	Cable Loss (dB)	Preamp Factor (dB)	Antenna Height (cm)	Table Angle (Degree)	Remark
5320	85.07	76.49			34.25	8.35	34.02	258	322	Average
5320	91.72	83.14			34.25	8.35	34.02	258	322	Peak
5440.75	42.98	34.19	54	-11.02	34.35	8.48	34.04	258	322	Average
5440.75	53.52	44.73	74	-20.48	34.35	8.48	34.04	258	322	Peak
10640	48.25	33.52	54	-5.75	37.31	12.71	35.29	127	224	Average
10640	57.6	42.87	74	-16.4	37.31	12.71	35.29	127	224	Peak

Remarks:

- Emission Level = Read Level + Antenna Factor + Cable Loss - Preamp Factor
Margin value = Emission level – Limit value
- 5320 MHz: Fundamental Frequency
- *: Out of Restricted Band

EUT Test Condition		Measurement Detail	
Channel	Channel 100	Frequency Range	1 GHz ~ 40 GHz
Input Power	120 Vac, 60 Hz	Detector Function	Peak (PK) Average (AV)
Environmental Conditions	25 deg. C, 65 % RH	Tested By	Karl Lee

Antenna Polarity & Test Distance: Horizontal at 3 m										
Frequency (MHz)	Emission Level (dBuV/m)	Read Level (dBuV)	Limit (dBuV/m)	Margin (dB)	Antenna Factor (dB/m)	Cable Loss (dB)	Preamp Factor (dB)	Antenna Height (cm)	Table Angle (Degree)	Remark
5372.56	43.51	34.84	54	-10.49	34.29	8.41	34.03	221	56	Average
5372.56	53.4	44.73	74	-20.6	34.29	8.41	34.03	221	56	Peak
*5469.68	54.69	45.86	68.2	-13.51	34.37	8.51	34.05	221	56	Peak
5500	94.31	85.39			34.4	8.57	34.05	221	56	Average
5500	100.92	92			34.4	8.57	34.05	221	56	Peak
11000	48.17	33.09	54	-5.83	37.6	12.96	35.48	196	224	Average
11000	57.58	42.5	74	-16.42	37.6	12.96	35.48	196	224	Peak
Antenna Polarity & Test Distance: Vertical at 3 m										
Frequency (MHz)	Emission Level (dBuV/m)	Read Level (dBuV)	Limit (dBuV/m)	Margin (dB)	Antenna Factor (dB/m)	Cable Loss (dB)	Preamp Factor (dB)	Antenna Height (cm)	Table Angle (Degree)	Remark
5456.08	42.99	34.17	54	-11.01	34.36	8.51	34.05	245	345	Average
5456.08	53.97	45.15	74	-20.03	34.36	8.51	34.05	245	345	Peak
*5468.4	52.91	44.08	68.2	-15.29	34.37	8.51	34.05	245	345	Peak
5500	84.88	75.96			34.4	8.57	34.05	245	345	Average
5500	91.47	82.55			34.4	8.57	34.05	245	345	Peak
11000	49.93	34.85	54	-4.07	37.6	12.96	35.48	157	143	Average
11000	59.06	43.98	74	-14.94	37.6	12.96	35.48	157	143	Peak

Remarks:

- Emission Level = Read Level + Antenna Factor + Cable Loss - Preamp Factor
Margin value = Emission level – Limit value
- 5500 MHz: Fundamental Frequency
- *: Out of Restricted Band

EUT Test Condition		Measurement Detail	
Channel	Channel 116	Frequency Range	1 GHz ~ 40 GHz
Input Power	120 Vac, 60 Hz	Detector Function	Peak (PK) Average (AV)
Environmental Conditions	25 deg. C, 65 % RH	Tested By	Karl Lee

Antenna Polarity & Test Distance: Horizontal at 3 m										
Frequency (MHz)	Emission Level (dBuV/m)	Read Level (dBuV)	Limit (dBuV/m)	Margin (dB)	Antenna Factor (dB/m)	Cable Loss (dB)	Preamp Factor (dB)	Antenna Height (cm)	Table Angle (Degree)	Remark
5421.36	43.02	34.25	54	-10.98	34.33	8.48	34.04	221	56	Average
5421.36	53.6	44.83	74	-20.4	34.33	8.48	34.04	221	56	Peak
5469.52	52.15	43.32	74	-21.85	34.37	8.51	34.05	221	56	Peak
5580	94.37	85.38			34.47	8.6	34.08	221	56	Average
5580	101.71	92.72			34.47	8.6	34.08	221	56	Peak
5723.96	53.04	43.88	74	-20.96	34.62	8.65	34.11	221	56	Peak

Antenna Polarity & Test Distance: Vertical at 3 m										
Frequency (MHz)	Emission Level (dBuV/m)	Read Level (dBuV)	Limit (dBuV/m)	Margin (dB)	Antenna Factor (dB/m)	Cable Loss (dB)	Preamp Factor (dB)	Antenna Height (cm)	Table Angle (Degree)	Remark
5458.32	42.84	34.02	54	-11.16	34.36	8.51	34.05	245	345	Average
5458.32	53.61	44.79	74	-20.39	34.36	8.51	34.05	245	345	Peak
5470.64	53.36	44.53	74	-20.64	34.37	8.51	34.05	245	345	Peak
5580	84.96	75.97			34.47	8.6	34.08	245	345	Average
5580	91.97	82.98			34.47	8.6	34.08	245	345	Peak
5725.16	53.26	44.1	74	-20.74	34.62	8.65	34.11	245	345	Peak

Remarks:

- Emission Level = Read Level + Antenna Factor + Cable Loss - Preamp Factor
Margin value = Emission level – Limit value
- 5580 MHz: Fundamental Frequency
- *: Out of Restricted Band

EUT Test Condition		Measurement Detail	
Channel	Channel 140	Frequency Range	1 GHz ~ 40 GHz
Input Power	120 Vac, 60 Hz	Detector Function	Peak (PK) Average (AV)
Environmental Conditions	25 deg. C, 65 % RH	Tested By	Karl Lee

Antenna Polarity & Test Distance: Horizontal at 3 m										
Frequency (MHz)	Emission Level (dBuV/m)	Read Level (dBuV)	Limit (dBuV/m)	Margin (dB)	Antenna Factor (dB/m)	Cable Loss (dB)	Preamp Factor (dB)	Antenna Height (cm)	Table Angle (Degree)	Remark
5700	93.61	84.48			34.59	8.64	34.1	221	56	Average
5700	100.46	91.33			34.59	8.64	34.1	221	56	Peak
*5724.6	53.78	44.62	68.2	-14.42	34.62	8.65	34.11	221	56	Peak
11400	48.12	33.02	54	-5.88	37.84	12.67	35.41	196	107	Average
11400	57.38	42.28	74	-16.62	37.84	12.67	35.41	196	107	Peak

Antenna Polarity & Test Distance: Vertical at 3 m										
Frequency (MHz)	Emission Level (dBuV/m)	Read Level (dBuV)	Limit (dBuV/m)	Margin (dB)	Antenna Factor (dB/m)	Cable Loss (dB)	Preamp Factor (dB)	Antenna Height (cm)	Table Angle (Degree)	Remark
5700	83.93	74.8			34.59	8.64	34.1	253	320	Average
5700	91.11	81.98			34.59	8.64	34.1	253	320	Peak
*5725.4	52.46	43.3	68.2	-15.74	34.62	8.65	34.11	253	320	Peak
11400	48.1	33	54	-5.9	37.84	12.67	35.41	158	273	Average
11400	57.48	42.38	74	-16.52	37.84	12.67	35.41	158	273	Peak

Remarks:

- Emission Level = Read Level + Antenna Factor + Cable Loss - Preamp Factor
Margin value = Emission level – Limit value
- 5700 MHz: Fundamental Frequency
- *: Out of Restricted Band

802.11n (HT20)

EUT Test Condition		Measurement Detail	
Channel	Channel 36	Frequency Range	1 GHz ~ 40 GHz
Input Power	120 Vac, 60 Hz	Detector Function	Peak (PK) Average (AV)
Environmental Conditions	25 deg. C, 65 % RH	Tested By	Karl Lee

Antenna Polarity & Test Distance: Horizontal at 3 m

Frequency (MHz)	Emission Level (dBuV/m)	Read Level (dBuV)	Limit (dBuV/m)	Margin (dB)	Antenna Factor (dB/m)	Cable Loss (dB)	Preamp Factor (dB)	Antenna Height (cm)	Table Angle (Degree)	Remark
5144.15	43.2	34.95	54	-10.8	34.12	8.13	34	226	58	Average
5144.15	56.14	47.89	74	-17.86	34.12	8.13	34	226	58	Peak
5180	98.02	89.71			34.15	8.16	34	226	58	Average
5180	105.69	97.38			34.15	8.16	34	226	58	Peak
*10360	56.5	42.2	68.2	-11.7	37.12	12.3	35.12	122	63	Peak

Antenna Polarity & Test Distance: Vertical at 3 m

Frequency (MHz)	Emission Level (dBuV/m)	Read Level (dBuV)	Limit (dBuV/m)	Margin (dB)	Antenna Factor (dB/m)	Cable Loss (dB)	Preamp Factor (dB)	Antenna Height (cm)	Table Angle (Degree)	Remark
5004.95	42.67	34.66	54	-11.33	34.01	7.97	33.97	291	308	Average
5004.95	53.18	45.17	74	-20.82	34.01	7.97	33.97	291	308	Peak
5180	86.59	78.28			34.15	8.16	34	291	308	Average
5180	93.87	85.56			34.15	8.16	34	291	308	Peak
*10360	56.03	41.73	68.2	-12.17	37.12	12.3	35.12	174	213	Peak

Remarks:

- Emission Level = Read Level + Antenna Factor + Cable Loss - Preamp Factor
Margin value = Emission level – Limit value
- 5180 MHz: Fundamental Frequency
- *: Out of Restricted Band

EUT Test Condition		Measurement Detail	
Channel	Channel 44	Frequency Range	1 GHz ~ 40 GHz
Input Power	120 Vac, 60 Hz	Detector Function	Peak (PK) Average (AV)
Environmental Conditions	25 deg. C, 65 % RH	Tested By	Karl Lee

Antenna Polarity & Test Distance: Horizontal at 3 m										
Frequency (MHz)	Emission Level (dBuV/m)	Read Level (dBuV)	Limit (dBuV/m)	Margin (dB)	Antenna Factor (dB/m)	Cable Loss (dB)	Preamp Factor (dB)	Antenna Height (cm)	Table Angle (Degree)	Remark
5119.4	42.93	34.73	54	-11.07	34.09	8.1	33.99	226	58	Average
5119.4	53.42	45.22	74	-20.58	34.09	8.1	33.99	226	58	Peak
5220	98.16	89.77			34.17	8.22	34	226	58	Average
5220	105.52	97.13			34.17	8.22	34	226	58	Peak
5375.08	43.28	34.62	54	-10.72	34.29	8.41	34.04	226	58	Average
5375.08	54.21	45.55	74	-19.79	34.29	8.41	34.04	226	58	Peak

Antenna Polarity & Test Distance: Vertical at 3 m										
Frequency (MHz)	Emission Level (dBuV/m)	Read Level (dBuV)	Limit (dBuV/m)	Margin (dB)	Antenna Factor (dB/m)	Cable Loss (dB)	Preamp Factor (dB)	Antenna Height (cm)	Table Angle (Degree)	Remark
5045	42.68	34.62	54	-11.32	34.04	8	33.98	291	308	Average
5045	53.17	45.11	74	-20.83	34.04	8	33.98	291	308	Peak
5220	86.01	77.62			34.17	8.22	34	291	308	Average
5220	93.3	84.91			34.17	8.22	34	291	308	Peak
5365.07	43.01	34.37	54	-10.99	34.29	8.38	34.03	291	308	Average
5365.07	53.77	45.13	74	-20.23	34.29	8.38	34.03	291	308	Peak

Remarks:

- Emission Level = Read Level + Antenna Factor + Cable Loss - Preamp Factor
Margin value = Emission level – Limit value
- 5220 MHz: Fundamental Frequency
- *: Out of Restricted Band

EUT Test Condition		Measurement Detail	
Channel	Channel 48	Frequency Range	1 GHz ~ 40 GHz
Input Power	120 Vac, 60 Hz	Detector Function	Peak (PK) Average (AV)
Environmental Conditions	25 deg. C, 65 % RH	Tested By	Karl Lee

Antenna Polarity & Test Distance: Horizontal at 3 m										
Frequency (MHz)	Emission Level (dBuV/m)	Read Level (dBuV)	Limit (dBuV/m)	Margin (dB)	Antenna Factor (dB/m)	Cable Loss (dB)	Preamp Factor (dB)	Antenna Height (cm)	Table Angle (Degree)	Remark
5240	98.35	89.91			34.19	8.26	34.01	226	58	Average
5240	106.29	97.85			34.19	8.26	34.01	226	58	Peak
5454.83	43.29	34.47	54	-10.71	34.36	8.51	34.05	226	58	Average
5454.83	53.98	45.16	74	-20.02	34.36	8.51	34.05	226	58	Peak
*10480	57.14	42.63	68.2	-11.06	37.19	12.53	35.21	163	287	Peak

Antenna Polarity & Test Distance: Vertical at 3 m										
Frequency (MHz)	Emission Level (dBuV/m)	Read Level (dBuV)	Limit (dBuV/m)	Margin (dB)	Antenna Factor (dB/m)	Cable Loss (dB)	Preamp Factor (dB)	Antenna Height (cm)	Table Angle (Degree)	Remark
5240	85.36	76.92			34.19	8.26	34.01	291	308	Average
5240	93.37	84.93			34.19	8.26	34.01	291	308	Peak
5448.45	42.92	34.09	54	-11.08	34.36	8.51	34.04	291	308	Average
5448.45	53.9	45.07	74	-20.1	34.36	8.51	34.04	291	308	Peak
*10480	56.64	42.13	68.2	-11.56	37.19	12.53	35.21	136	229	Peak

Remarks:

- Emission Level = Read Level + Antenna Factor + Cable Loss - Preamp Factor
Margin value = Emission level – Limit value
- 5240 MHz: Fundamental Frequency
- *: Out of Restricted Band

EUT Test Condition		Measurement Detail	
Channel	Channel 52	Frequency Range	1 GHz ~ 40 GHz
Input Power	120 Vac, 60 Hz	Detector Function	Peak (PK) Average (AV)
Environmental Conditions	25 deg. C, 65 % RH	Tested By	Karl Lee

Antenna Polarity & Test Distance: Horizontal at 3 m										
Frequency (MHz)	Emission Level (dBuV/m)	Read Level (dBuV)	Limit (dBuV/m)	Margin (dB)	Antenna Factor (dB/m)	Cable Loss (dB)	Preamp Factor (dB)	Antenna Height (cm)	Table Angle (Degree)	Remark
5106.2	42.9	34.73	54	-11.1	34.09	8.07	33.99	220	58	Average
5106.2	54.1	45.93	74	-19.9	34.09	8.07	33.99	220	58	Peak
5260	98.66	90.2			34.21	8.26	34.01	220	58	Average
5260	105.51	97.05			34.21	8.26	34.01	220	58	Peak
*10520	56.94	42.35	68.2	-11.26	37.21	12.61	35.23	196	328	Peak

Antenna Polarity & Test Distance: Vertical at 3 m										
Frequency (MHz)	Emission Level (dBuV/m)	Read Level (dBuV)	Limit (dBuV/m)	Margin (dB)	Antenna Factor (dB/m)	Cable Loss (dB)	Preamp Factor (dB)	Antenna Height (cm)	Table Angle (Degree)	Remark
5107.4	42.72	34.52	54	-11.28	34.09	8.1	33.99	291	350	Average
5107.4	53.39	45.19	74	-20.61	34.09	8.1	33.99	291	350	Peak
5260	86.57	78.11			34.21	8.26	34.01	291	350	Average
5260	94.86	86.4			34.21	8.26	34.01	291	350	Peak
*10520	56.49	41.9	68.2	-11.71	37.21	12.61	35.23	124	115	Peak

Remarks:

- Emission Level = Read Level + Antenna Factor + Cable Loss - Preamp Factor
Margin value = Emission level – Limit value
- 5260 MHz: Fundamental Frequency
- *: Out of Restricted Band

EUT Test Condition		Measurement Detail	
Channel	Channel 60	Frequency Range	1 GHz ~ 40 GHz
Input Power	120 Vac, 60 Hz	Detector Function	Peak (PK) Average (AV)
Environmental Conditions	25 deg. C, 65 % RH	Tested By	Karl Lee

Antenna Polarity & Test Distance: Horizontal at 3 m										
Frequency (MHz)	Emission Level (dBuV/m)	Read Level (dBuV)	Limit (dBuV/m)	Margin (dB)	Antenna Factor (dB/m)	Cable Loss (dB)	Preamp Factor (dB)	Antenna Height (cm)	Table Angle (Degree)	Remark
5139.65	42.73	34.47	54	-11.27	34.12	8.13	33.99	220	58	Average
5139.65	54.06	45.8	74	-19.94	34.12	8.13	33.99	220	58	Peak
5300	98.64	90.1			34.24	8.32	34.02	220	58	Average
5300	106.16	97.62			34.24	8.32	34.02	220	58	Peak
5351.32	43.45	34.82	54	-10.55	34.28	8.38	34.03	220	58	Average
5351.32	57.03	48.4	74	-16.97	34.28	8.38	34.03	220	58	Peak
Antenna Polarity & Test Distance: Vertical at 3 m										
Frequency (MHz)	Emission Level (dBuV/m)	Read Level (dBuV)	Limit (dBuV/m)	Margin (dB)	Antenna Factor (dB/m)	Cable Loss (dB)	Preamp Factor (dB)	Antenna Height (cm)	Table Angle (Degree)	Remark
5125.1	42.87	34.65	54	-11.13	34.11	8.1	33.99	291	350	Average
5125.1	53.04	44.82	74	-20.96	34.11	8.1	33.99	291	350	Peak
5300	85.93	77.39			34.24	8.32	34.02	291	350	Average
5300	94.04	85.5			34.24	8.32	34.02	291	350	Peak
5428.65	42.95	34.16	54	-11.05	34.35	8.48	34.04	291	350	Average
5428.65	53.55	44.76	74	-20.45	34.35	8.48	34.04	291	350	Peak

Remarks:

- Emission Level = Read Level + Antenna Factor + Cable Loss - Preamp Factor
Margin value = Emission level – Limit value
- 5300 MHz: Fundamental Frequency
- *: Out of Restricted Band

EUT Test Condition		Measurement Detail	
Channel	Channel 64	Frequency Range	1 GHz ~ 40 GHz
Input Power	120 Vac, 60 Hz	Detector Function	Peak (PK) Average (AV)
Environmental Conditions	25 deg. C, 65 % RH	Tested By	Karl Lee

Antenna Polarity & Test Distance: Horizontal at 3 m										
Frequency (MHz)	Emission Level (dBuV/m)	Read Level (dBuV)	Limit (dBuV/m)	Margin (dB)	Antenna Factor (dB/m)	Cable Loss (dB)	Preamp Factor (dB)	Antenna Height (cm)	Table Angle (Degree)	Remark
5320	98.72	90.14			34.25	8.35	34.02	220	58	Average
5320	106.08	97.5			34.25	8.35	34.02	220	58	Peak
5351.43	43.71	35.08	54	-10.29	34.28	8.38	34.03	220	58	Average
5351.43	59.15	50.52	74	-14.85	34.28	8.38	34.03	220	58	Peak
10640	48.63	33.9	54	-5.37	37.31	12.71	35.29	187	254	Average
10640	58.32	43.59	74	-15.68	37.31	12.71	35.29	187	254	Peak

Antenna Polarity & Test Distance: Vertical at 3 m										
Frequency (MHz)	Emission Level (dBuV/m)	Read Level (dBuV)	Limit (dBuV/m)	Margin (dB)	Antenna Factor (dB/m)	Cable Loss (dB)	Preamp Factor (dB)	Antenna Height (cm)	Table Angle (Degree)	Remark
5320	86.92	78.34			34.25	8.35	34.02	291	310	Average
5320	94.32	85.74			34.25	8.35	34.02	291	310	Peak
5416.77	42.86	34.13	54	-11.14	34.33	8.44	34.04	291	310	Average
5416.77	54.21	45.48	74	-19.79	34.33	8.44	34.04	291	310	Peak
10640	48.25	33.52	54	-5.75	37.31	12.71	35.29	182	133	Average
10640	57.58	42.85	74	-16.42	37.31	12.71	35.29	182	133	Peak

Remarks:

- Emission Level = Read Level + Antenna Factor + Cable Loss - Preamp Factor
Margin value = Emission level – Limit value
- 5320 MHz: Fundamental Frequency
- *: Out of Restricted Band

EUT Test Condition		Measurement Detail	
Channel	Channel 100	Frequency Range	1 GHz ~ 40 GHz
Input Power	120 Vac, 60 Hz	Detector Function	Peak (PK) Average (AV)
Environmental Conditions	25 deg. C, 65 % RH	Tested By	Karl Lee

Antenna Polarity & Test Distance: Horizontal at 3 m										
Frequency (MHz)	Emission Level (dBuV/m)	Read Level (dBuV)	Limit (dBuV/m)	Margin (dB)	Antenna Factor (dB/m)	Cable Loss (dB)	Preamp Factor (dB)	Antenna Height (cm)	Table Angle (Degree)	Remark
5459.44	43.26	34.44	54	-10.74	34.36	8.51	34.05	212	65	Average
5459.44	54.06	45.24	74	-19.94	34.36	8.51	34.05	212	65	Peak
*5470.32	52.67	43.84	68.2	-15.53	34.37	8.51	34.05	212	65	Peak
5500	94.89	85.97			34.4	8.57	34.05	212	65	Average
5500	102.28	93.36			34.4	8.57	34.05	212	65	Peak
11000	48.67	33.59	54	-5.33	37.6	12.96	35.48	105	237	Average
11000	58.36	43.28	74	-15.64	37.6	12.96	35.48	105	237	Peak
Antenna Polarity & Test Distance: Vertical at 3 m										
Frequency (MHz)	Emission Level (dBuV/m)	Read Level (dBuV)	Limit (dBuV/m)	Margin (dB)	Antenna Factor (dB/m)	Cable Loss (dB)	Preamp Factor (dB)	Antenna Height (cm)	Table Angle (Degree)	Remark
5414.32	42.95	34.22	54	-11.05	34.33	8.44	34.04	289	360	Average
5414.32	54.09	45.36	74	-19.91	34.33	8.44	34.04	289	360	Peak
*5469.52	52.86	44.03	68.2	-15.34	34.37	8.51	34.05	289	360	Peak
5500	85.54	76.62			34.4	8.57	34.05	289	360	Average
5500	93.68	84.76			34.4	8.57	34.05	289	360	Peak
11000	48.1	33.02	54	-5.9	37.6	12.96	35.48	156	129	Average
11000	57.93	42.85	74	-16.07	37.6	12.96	35.48	156	129	Peak

Remarks:

- Emission Level = Read Level + Antenna Factor + Cable Loss - Preamp Factor
Margin value = Emission level – Limit value
- 5500 MHz: Fundamental Frequency
- *: Out of Restricted Band

EUT Test Condition		Measurement Detail	
Channel	Channel 116	Frequency Range	1 GHz ~ 40 GHz
Input Power	120 Vac, 60 Hz	Detector Function	Peak (PK) Average (AV)
Environmental Conditions	25 deg. C, 65 % RH	Tested By	Karl Lee

Antenna Polarity & Test Distance: Horizontal at 3 m										
Frequency (MHz)	Emission Level (dBuV/m)	Read Level (dBuV)	Limit (dBuV/m)	Margin (dB)	Antenna Factor (dB/m)	Cable Loss (dB)	Preamp Factor (dB)	Antenna Height (cm)	Table Angle (Degree)	Remark
5365.52	42.91	34.27	54	-11.09	34.29	8.38	34.03	212	65	Average
5365.52	53.37	44.73	74	-20.63	34.29	8.38	34.03	212	65	Peak
*5468.24	53.78	44.95	68.2	-14.42	34.37	8.51	34.05	212	65	Peak
5580	95.2	86.21			34.47	8.6	34.08	212	65	Average
5580	102.37	93.38			34.47	8.6	34.08	212	65	Peak
*5726.04	53.57	44.41	68.2	-14.63	34.62	8.65	34.11	212	65	Peak

Antenna Polarity & Test Distance: Vertical at 3 m										
Frequency (MHz)	Emission Level (dBuV/m)	Read Level (dBuV)	Limit (dBuV/m)	Margin (dB)	Antenna Factor (dB/m)	Cable Loss (dB)	Preamp Factor (dB)	Antenna Height (cm)	Table Angle (Degree)	Remark
5358.8	42.86	34.23	54	-11.14	34.28	8.38	34.03	289	360	Average
5358.8	53.18	44.55	74	-20.82	34.28	8.38	34.03	289	360	Peak
*5469.36	52.28	43.45	68.2	-15.92	34.37	8.51	34.05	289	360	Peak
5580	85.17	76.18			34.47	8.6	34.08	289	360	Average
5580	93.58	84.59			34.47	8.6	34.08	289	360	Peak
*5724.52	53.8	44.64	68.2	-14.4	34.62	8.65	34.11	289	360	Peak

Remarks:

- Emission Level = Read Level + Antenna Factor + Cable Loss - Preamp Factor
Margin value = Emission level – Limit value
- 5580 MHz: Fundamental Frequency
- *: Out of Restricted Band

EUT Test Condition		Measurement Detail	
Channel	Channel 140	Frequency Range	1 GHz ~ 40 GHz
Input Power	120 Vac, 60 Hz	Detector Function	Peak (PK) Average (AV)
Environmental Conditions	25 deg. C, 65 % RH	Tested By	Karl Lee

Antenna Polarity & Test Distance: Horizontal at 3 m										
Frequency (MHz)	Emission Level (dBuV/m)	Read Level (dBuV)	Limit (dBuV/m)	Margin (dB)	Antenna Factor (dB/m)	Cable Loss (dB)	Preamp Factor (dB)	Antenna Height (cm)	Table Angle (Degree)	Remark
5700	94.31	85.18			34.59	8.64	34.1	209	52	Average
5700	101.97	92.84			34.59	8.64	34.1	209	52	Peak
*5725.32	53.62	44.46	68.2	-14.58	34.62	8.65	34.11	209	52	Peak
11400	48.03	32.93	54	-5.97	37.84	12.67	35.41	158	226	Average
11400	57.28	42.18	74	-16.72	37.84	12.67	35.41	158	226	Peak

Antenna Polarity & Test Distance: Vertical at 3 m										
Frequency (MHz)	Emission Level (dBuV/m)	Read Level (dBuV)	Limit (dBuV/m)	Margin (dB)	Antenna Factor (dB/m)	Cable Loss (dB)	Preamp Factor (dB)	Antenna Height (cm)	Table Angle (Degree)	Remark
5700	85.65	76.52			34.59	8.64	34.1	289	360	Average
5700	93.3	84.17			34.59	8.64	34.1	289	360	Peak
*5724.04	53.25	44.09	68.2	-14.95	34.62	8.65	34.11	289	360	Peak
11400	49.27	34.17	54	-4.73	37.84	12.67	35.41	175	105	Average
11400	58.4	43.3	74	-15.6	37.84	12.67	35.41	175	105	Peak

Remarks:

- Emission Level = Read Level + Antenna Factor + Cable Loss - Preamp Factor
Margin value = Emission level – Limit value
- 5700 MHz: Fundamental Frequency
- *: Out of Restricted Band

802.11n (HT40)

EUT Test Condition		Measurement Detail	
Channel	Channel 38	Frequency Range	1 GHz ~ 40 GHz
Input Power	120 Vac, 60 Hz	Detector Function	Peak (PK) Average (AV)
Environmental Conditions	25 deg. C, 65 % RH	Tested By	Karl Lee

Antenna Polarity & Test Distance: Horizontal at 3 m

Frequency (MHz)	Emission Level (dBuV/m)	Read Level (dBuV)	Limit (dBuV/m)	Margin (dB)	Antenna Factor (dB/m)	Cable Loss (dB)	Preamp Factor (dB)	Antenna Height (cm)	Table Angle (Degree)	Remark
5128.25	43.62	35.4	54	-10.38	34.11	8.1	33.99	227	58	Average
5128.25	53.55	45.33	74	-20.45	34.11	8.1	33.99	227	58	Peak
5190	94.97	86.63			34.15	8.19	34	227	58	Average
5190	102.76	94.42			34.15	8.19	34	227	58	Peak
5400.82	43.52	34.8	54	-10.48	34.32	8.44	34.04	227	58	Average
5400.82	54.44	45.72	74	-19.56	34.32	8.44	34.04	227	58	Peak

Antenna Polarity & Test Distance: Vertical at 3 m

Frequency (MHz)	Emission Level (dBuV/m)	Read Level (dBuV)	Limit (dBuV/m)	Margin (dB)	Antenna Factor (dB/m)	Cable Loss (dB)	Preamp Factor (dB)	Antenna Height (cm)	Table Angle (Degree)	Remark
5130.2	43.1	34.88	54	-10.9	34.11	8.1	33.99	270	308	Average
5130.2	54.28	46.06	74	-19.72	34.11	8.1	33.99	270	308	Peak
5190	83.36	75.02			34.15	8.19	34	270	308	Average
5190	90.79	82.45			34.15	8.19	34	270	308	Peak
5394.99	43.33	34.61	54	-10.67	34.32	8.44	34.04	270	308	Average
5394.99	53.93	45.21	74	-20.07	34.32	8.44	34.04	270	308	Peak

Remarks:

- Emission Level = Read Level + Antenna Factor + Cable Loss - Preamp Factor
Margin value = Emission level – Limit value
- 5190 MHz: Fundamental Frequency
- *: Out of Restricted Band

EUT Test Condition		Measurement Detail	
Channel	Channel 46	Frequency Range	1 GHz ~ 40 GHz
Input Power	120 Vac, 60 Hz	Detector Function	Peak (PK) Average (AV)
Environmental Conditions	25 deg. C, 65 % RH	Tested By	Karl Lee

Antenna Polarity & Test Distance: Horizontal at 3 m										
Frequency (MHz)	Emission Level (dBuV/m)	Read Level (dBuV)	Limit (dBuV/m)	Margin (dB)	Antenna Factor (dB/m)	Cable Loss (dB)	Preamp Factor (dB)	Antenna Height (cm)	Table Angle (Degree)	Remark
5029.25	43.25	35.19	54	-10.75	34.03	8	33.97	227	58	Average
5029.25	53.29	45.23	74	-20.71	34.03	8	33.97	227	58	Peak
5230	95.08	86.68			34.19	8.22	34.01	227	58	Average
5230	102.41	94.01			34.19	8.22	34.01	227	58	Peak
5451.09	43.66	34.84	54	-10.34	34.36	8.51	34.05	227	58	Average
5451.09	54.08	45.26	74	-19.92	34.36	8.51	34.05	227	58	Peak

Antenna Polarity & Test Distance: Vertical at 3 m										
Frequency (MHz)	Emission Level (dBuV/m)	Read Level (dBuV)	Limit (dBuV/m)	Margin (dB)	Antenna Factor (dB/m)	Cable Loss (dB)	Preamp Factor (dB)	Antenna Height (cm)	Table Angle (Degree)	Remark
5044.25	43.13	35.07	54	-10.87	34.04	8	33.98	291	308	Average
5044.25	53.31	45.25	74	-20.69	34.04	8	33.98	291	308	Peak
5230	83.1	74.7			34.19	8.22	34.01	291	308	Average
5230	90.11	81.71			34.19	8.22	34.01	291	308	Peak
5405.77	43.42	34.7	54	-10.58	34.32	8.44	34.04	291	308	Average
5405.77	53.44	44.72	74	-20.56	34.32	8.44	34.04	291	308	Peak

Remarks:

- Emission Level = Read Level + Antenna Factor + Cable Loss - Preamp Factor
Margin value = Emission level – Limit value
- 5230 MHz: Fundamental Frequency
- *: Out of Restricted Band

EUT Test Condition		Measurement Detail	
Channel	Channel 54	Frequency Range	1 GHz ~ 40 GHz
Input Power	120 Vac, 60 Hz	Detector Function	Peak (PK) Average (AV)
Environmental Conditions	25 deg. C, 65 % RH	Tested By	Karl Lee

Antenna Polarity & Test Distance: Horizontal at 3 m										
Frequency (MHz)	Emission Level (dBuV/m)	Read Level (dBuV)	Limit (dBuV/m)	Margin (dB)	Antenna Factor (dB/m)	Cable Loss (dB)	Preamp Factor (dB)	Antenna Height (cm)	Table Angle (Degree)	Remark
5120.9	43.43	35.23	54	-10.57	34.09	8.1	33.99	220	58	Average
5120.9	54.43	46.23	74	-19.57	34.09	8.1	33.99	220	58	Peak
5270	94.84	86.35			34.21	8.29	34.01	220	58	Average
5270	102.62	94.13			34.21	8.29	34.01	220	58	Peak
5360.23	43.85	35.22	54	-10.15	34.28	8.38	34.03	220	58	Average
5360.23	53.36	44.73	74	-20.64	34.28	8.38	34.03	220	58	Peak

Antenna Polarity & Test Distance: Vertical at 3 m										
Frequency (MHz)	Emission Level (dBuV/m)	Read Level (dBuV)	Limit (dBuV/m)	Margin (dB)	Antenna Factor (dB/m)	Cable Loss (dB)	Preamp Factor (dB)	Antenna Height (cm)	Table Angle (Degree)	Remark
5149.25	43.33	35.08	54	-10.67	34.12	8.13	34	291	350	Average
5149.25	53.55	45.3	74	-20.45	34.12	8.13	34	291	350	Peak
5270	84.24	75.75			34.21	8.29	34.01	291	350	Average
5270	91.44	82.95			34.21	8.29	34.01	291	350	Peak
5451.09	43.46	34.64	54	-10.54	34.36	8.51	34.05	291	350	Average
5451.09	53.58	44.76	74	-20.42	34.36	8.51	34.05	291	350	Peak

Remarks:

- Emission Level = Read Level + Antenna Factor + Cable Loss - Preamp Factor
Margin value = Emission level – Limit value
- 5270 MHz: Fundamental Frequency
- *: Out of Restricted Band

EUT Test Condition		Measurement Detail	
Channel	Channel 62	Frequency Range	1 GHz ~ 40 GHz
Input Power	120 Vac, 60 Hz	Detector Function	Peak (PK) Average (AV)
Environmental Conditions	25 deg. C, 65 % RH	Tested By	Karl Lee

Antenna Polarity & Test Distance: Horizontal at 3 m										
Frequency (MHz)	Emission Level (dBuV/m)	Read Level (dBuV)	Limit (dBuV/m)	Margin (dB)	Antenna Factor (dB/m)	Cable Loss (dB)	Preamp Factor (dB)	Antenna Height (cm)	Table Angle (Degree)	Remark
5088.05	43.28	35.12	54	-10.72	34.07	8.07	33.98	220	58	Average
5088.05	53.5	45.34	74	-20.5	34.07	8.07	33.98	220	58	Peak
5310	95.51	86.96			34.25	8.32	34.02	220	58	Average
5310	102.58	94.03			34.25	8.32	34.02	220	58	Peak
5351.54	45.6	36.97	54	-8.4	34.28	8.38	34.03	220	58	Average
5351.54	59.74	51.11	74	-14.26	34.28	8.38	34.03	220	58	Peak

Antenna Polarity & Test Distance: Vertical at 3 m										
Frequency (MHz)	Emission Level (dBuV/m)	Read Level (dBuV)	Limit (dBuV/m)	Margin (dB)	Antenna Factor (dB/m)	Cable Loss (dB)	Preamp Factor (dB)	Antenna Height (cm)	Table Angle (Degree)	Remark
5130.95	42.74	34.52	54	-11.26	34.11	8.1	33.99	291	310	Average
5130.95	54.41	46.19	74	-19.59	34.11	8.1	33.99	291	310	Peak
5310	84.06	75.51			34.25	8.32	34.02	291	310	Average
5310	91.21	82.66			34.25	8.32	34.02	291	310	Peak
5453.95	42.87	34.05	54	-11.13	34.36	8.51	34.05	291	310	Average
5453.95	54.07	45.25	74	-19.93	34.36	8.51	34.05	291	310	Peak

Remarks:

- Emission Level = Read Level + Antenna Factor + Cable Loss - Preamp Factor
Margin value = Emission level – Limit value
- 5310 MHz: Fundamental Frequency
- *: Out of Restricted Band

EUT Test Condition		Measurement Detail	
Channel	Channel 102	Frequency Range	1 GHz ~ 40 GHz
Input Power	120 Vac, 60 Hz	Detector Function	Peak (PK) Average (AV)
Environmental Conditions	25 deg. C, 65 % RH	Tested By	Karl Lee

Antenna Polarity & Test Distance: Horizontal at 3 m										
Frequency (MHz)	Emission Level (dBuV/m)	Read Level (dBuV)	Limit (dBuV/m)	Margin (dB)	Antenna Factor (dB/m)	Cable Loss (dB)	Preamp Factor (dB)	Antenna Height (cm)	Table Angle (Degree)	Remark
5431.6	43.68	34.89	54	-10.32	34.35	8.48	34.04	212	65	Average
5431.6	54.07	45.28	74	-19.93	34.35	8.48	34.04	212	65	Peak
*5469.68	53.92	45.09	68.2	-14.28	34.37	8.51	34.05	212	65	Peak
5510	92.72	83.81			34.4	8.57	34.06	212	65	Average
5510	99.65	90.74			34.4	8.57	34.06	212	65	Peak
*5724.52	53.18	44.02	68.2	-15.02	34.62	8.65	34.11	212	65	Peak

Antenna Polarity & Test Distance: Vertical at 3 m										
Frequency (MHz)	Emission Level (dBuV/m)	Read Level (dBuV)	Limit (dBuV/m)	Margin (dB)	Antenna Factor (dB/m)	Cable Loss (dB)	Preamp Factor (dB)	Antenna Height (cm)	Table Angle (Degree)	Remark
5440.08	43.42	34.63	54	-10.58	34.35	8.48	34.04	289	360	Average
5440.08	53.5	44.71	74	-20.5	34.35	8.48	34.04	289	360	Peak
*5468.08	51.82	42.99	68.2	-16.38	34.37	8.51	34.05	289	360	Peak
5510	83.01	74.1			34.4	8.57	34.06	289	360	Average
5510	89.97	81.06			34.4	8.57	34.06	289	360	Peak
*5725.4	52.83	43.67	68.2	-15.37	34.62	8.65	34.11	289	360	Peak

Remarks:

- Emission Level = Read Level + Antenna Factor + Cable Loss - Preamp Factor
Margin value = Emission level – Limit value
- 5510 MHz: Fundamental Frequency
- *: Out of Restricted Band

EUT Test Condition		Measurement Detail	
Channel	Channel 110	Frequency Range	1 GHz ~ 40 GHz
Input Power	120 Vac, 60 Hz	Detector Function	Peak (PK) Average (AV)
Environmental Conditions	25 deg. C, 65 % RH	Tested By	Karl Lee

Antenna Polarity & Test Distance: Horizontal at 3 m										
Frequency (MHz)	Emission Level (dBuV/m)	Read Level (dBuV)	Limit (dBuV/m)	Margin (dB)	Antenna Factor (dB/m)	Cable Loss (dB)	Preamp Factor (dB)	Antenna Height (cm)	Table Angle (Degree)	Remark
5415.76	43.45	34.72	54	-10.55	34.33	8.44	34.04	212	65	Average
5415.76	53.2	44.47	74	-20.8	34.33	8.44	34.04	212	65	Peak
*5469.2	51.98	43.15	68.2	-16.22	34.37	8.51	34.05	212	65	Peak
5550	92.33	83.36			34.45	8.59	34.07	212	65	Average
5550	99.6	90.63			34.45	8.59	34.07	212	65	Peak
*5725.72	53.41	44.25	68.2	-14.79	34.62	8.65	34.11	212	65	Peak

Antenna Polarity & Test Distance: Vertical at 3 m										
Frequency (MHz)	Emission Level (dBuV/m)	Read Level (dBuV)	Limit (dBuV/m)	Margin (dB)	Antenna Factor (dB/m)	Cable Loss (dB)	Preamp Factor (dB)	Antenna Height (cm)	Table Angle (Degree)	Remark
5420.88	43.39	34.62	54	-10.61	34.33	8.48	34.04	289	360	Average
5420.88	53.27	44.5	74	-20.73	34.33	8.48	34.04	289	360	Peak
*5470.32	52.71	43.88	68.2	-15.49	34.37	8.51	34.05	289	360	Peak
5550	83.99	75.02			34.45	8.59	34.07	289	360	Average
5550	90.61	81.64			34.45	8.59	34.07	289	360	Peak
*5725.08	52.66	43.5	68.2	-15.54	34.62	8.65	34.11	289	360	Peak

Remarks:

- Emission Level = Read Level + Antenna Factor + Cable Loss - Preamp Factor
Margin value = Emission level – Limit value
- 5550 MHz: Fundamental Frequency
- *: Out of Restricted Band

EUT Test Condition		Measurement Detail	
Channel	Channel 134	Frequency Range	1 GHz ~ 40 GHz
Input Power	120 Vac, 60 Hz	Detector Function	Peak (PK) Average (AV)
Environmental Conditions	25 deg. C, 65 % RH	Tested By	Karl Lee

Antenna Polarity & Test Distance: Horizontal at 3 m										
Frequency (MHz)	Emission Level (dBuV/m)	Read Level (dBuV)	Limit (dBuV/m)	Margin (dB)	Antenna Factor (dB/m)	Cable Loss (dB)	Preamp Factor (dB)	Antenna Height (cm)	Table Angle (Degree)	Remark
5357.52	43.38	34.75	54	-10.62	34.28	8.38	34.03	209	52	Average
5357.52	53.65	45.02	74	-20.35	34.28	8.38	34.03	209	52	Peak
*5469.68	52.22	43.39	68.2	-15.98	34.37	8.51	34.05	209	52	Peak
5670	92.33	83.23			34.57	8.63	34.1	209	52	Average
5670	99.47	90.37			34.57	8.63	34.1	209	52	Peak
*5725.08	53.87	44.71	68.2	-14.33	34.62	8.65	34.11	209	52	Peak

Antenna Polarity & Test Distance: Vertical at 3 m										
Frequency (MHz)	Emission Level (dBuV/m)	Read Level (dBuV)	Limit (dBuV/m)	Margin (dB)	Antenna Factor (dB/m)	Cable Loss (dB)	Preamp Factor (dB)	Antenna Height (cm)	Table Angle (Degree)	Remark
5423.76	43.33	34.56	54	-10.67	34.33	8.48	34.04	289	360	Average
5423.76	53.73	44.96	74	-20.27	34.33	8.48	34.04	289	360	Peak
*5468.08	51.87	43.04	68.2	-16.33	34.37	8.51	34.05	289	360	Peak
5670	83.78	74.68			34.57	8.63	34.1	289	360	Average
5670	91.06	81.96			34.57	8.63	34.1	289	360	Peak
*5724.6	52.85	43.69	68.2	-15.35	34.62	8.65	34.11	289	360	Peak

Remarks:

- Emission Level = Read Level + Antenna Factor + Cable Loss - Preamp Factor
Margin value = Emission level – Limit value
- 5670 MHz: Fundamental Frequency
- *: Out of Restricted Band

802.11ac (VHT80)

EUT Test Condition		Measurement Detail	
Channel	Channel 42	Frequency Range	1 GHz ~ 40 GHz
Input Power	120 Vac, 60 Hz	Detector Function	Peak (PK) Average (AV)
Environmental Conditions	25 deg. C, 65 % RH	Tested By	Karl Lee

Antenna Polarity & Test Distance: Horizontal at 3 m

Frequency (MHz)	Emission Level (dBuV/m)	Read Level (dBuV)	Limit (dBuV/m)	Margin (dB)	Antenna Factor (dB/m)	Cable Loss (dB)	Preamp Factor (dB)	Antenna Height (cm)	Table Angle (Degree)	Remark
5139.8	44.45	36.19	54	-9.55	34.12	8.13	33.99	223	58	Average
5139.8	54.49	46.23	74	-19.51	34.12	8.13	33.99	223	58	Peak
5210	92.56	84.2			34.17	8.19	34	223	58	Average
5210	99.84	91.48			34.17	8.19	34	223	58	Peak
5452.63	44.01	1.14	54	-9.99	34.36	8.51	0	223	58	Average
5452.63	53.86	45.04	74	-20.14	34.36	8.51	34.05	223	58	Peak

Antenna Polarity & Test Distance: Vertical at 3 m

Frequency (MHz)	Emission Level (dBuV/m)	Read Level (dBuV)	Limit (dBuV/m)	Margin (dB)	Antenna Factor (dB/m)	Cable Loss (dB)	Preamp Factor (dB)	Antenna Height (cm)	Table Angle (Degree)	Remark
5054	43.08	35.02	54	-10.92	34.04	8	33.98	256	309	Average
5054	53.13	45.07	74	-20.87	34.04	8	33.98	256	309	Peak
5210	81.23	72.87			34.17	8.19	34	256	309	Average
5210	88.97	80.61			34.17	8.19	34	256	309	Peak
5363.42	43.31	34.67	54	-10.69	34.29	8.38	34.03	256	309	Average
5363.42	53.37	44.73	74	-20.63	34.29	8.38	34.03	256	309	Peak

Remarks:

- Emission Level = Read Level + Antenna Factor + Cable Loss - Preamp Factor
Margin value = Emission level – Limit value
- 5210 MHz: Fundamental Frequency
- *: Out of Restricted Band

EUT Test Condition		Measurement Detail	
Channel	Channel 58	Frequency Range	1 GHz ~ 40 GHz
Input Power	120 Vac, 60 Hz	Detector Function	Peak (PK) Average (AV)
Environmental Conditions	25 deg. C, 65 % RH	Tested By	Karl Lee

Antenna Polarity & Test Distance: Horizontal at 3 m										
Frequency (MHz)	Emission Level (dBuV/m)	Read Level (dBuV)	Limit (dBuV/m)	Margin (dB)	Antenna Factor (dB/m)	Cable Loss (dB)	Preamp Factor (dB)	Antenna Height (cm)	Table Angle (Degree)	Remark
5048.9	43.46	35.4	54	-10.54	34.04	8	33.98	220	58	Average
5048.9	53.09	45.03	74	-20.91	34.04	8	33.98	220	58	Peak
5290	91.74	83.21			34.23	8.32	34.02	220	58	Average
5290	99.17	90.64			34.23	8.32	34.02	220	58	Peak
5365.4	47.34	38.7	54	-6.66	34.29	8.38	34.03	220	58	Average
5365.4	55.31	46.67	74	-18.69	34.29	8.38	34.03	220	58	Peak

Antenna Polarity & Test Distance: Vertical at 3 m										
Frequency (MHz)	Emission Level (dBuV/m)	Read Level (dBuV)	Limit (dBuV/m)	Margin (dB)	Antenna Factor (dB/m)	Cable Loss (dB)	Preamp Factor (dB)	Antenna Height (cm)	Table Angle (Degree)	Remark
5103.05	43.04	34.88	54	-10.96	34.08	8.07	33.99	291	350	Average
5103.05	53.43	45.27	74	-20.57	34.08	8.07	33.99	291	350	Peak
5290	81.63	73.1			34.23	8.32	34.02	291	350	Average
5290	88.83	80.3			34.23	8.32	34.02	291	350	Peak
5382.78	43.37	34.69	54	-10.63	34.31	8.41	34.04	291	350	Average
5382.78	53.44	44.76	74	-20.56	34.31	8.41	34.04	291	350	Peak

Remarks:

- Emission Level = Read Level + Antenna Factor + Cable Loss - Preamp Factor
Margin value = Emission level – Limit value
- 5290 MHz: Fundamental Frequency
- *: Out of Restricted Band

EUT Test Condition		Measurement Detail	
Channel	Channel 106	Frequency Range	1 GHz ~ 40 GHz
Input Power	120 Vac, 60 Hz	Detector Function	Peak (PK) Average (AV)
Environmental Conditions	25 deg. C, 65 % RH	Tested By	Karl Lee

Antenna Polarity & Test Distance: Horizontal at 3 m										
Frequency (MHz)	Emission Level (dBuV/m)	Read Level (dBuV)	Limit (dBuV/m)	Margin (dB)	Antenna Factor (dB/m)	Cable Loss (dB)	Preamp Factor (dB)	Antenna Height (cm)	Table Angle (Degree)	Remark
5401.52	44.34	35.62	54	-9.66	34.32	8.44	34.04	212	65	Average
5401.52	54.61	45.89	74	-19.39	34.32	8.44	34.04	212	65	Peak
*5468.88	53.2	44.37	68.2	-15	34.37	8.51	34.05	212	65	Peak
5530	90.17	81.24			34.42	8.58	34.07	212	65	Average
5530	96.91	87.98			34.42	8.58	34.07	212	65	Peak
*5724.44	53.05	43.89	68.2	-15.15	34.62	8.65	34.11	212	65	Peak

Antenna Polarity & Test Distance: Vertical at 3 m										
Frequency (MHz)	Emission Level (dBuV/m)	Read Level (dBuV)	Limit (dBuV/m)	Margin (dB)	Antenna Factor (dB/m)	Cable Loss (dB)	Preamp Factor (dB)	Antenna Height (cm)	Table Angle (Degree)	Remark
5417.68	43.56	34.83	54	-10.44	34.33	8.44	34.04	289	360	Average
5417.68	53.34	44.61	74	-20.66	34.33	8.44	34.04	289	360	Peak
*5469.84	52.63	43.8	68.2	-15.57	34.37	8.51	34.05	289	360	Peak
5530	81.24	72.31			34.42	8.58	34.07	289	360	Average
5530	88.34	79.41			34.42	8.58	34.07	289	360	Peak
*5725	52.01	42.85	68.2	-16.19	34.62	8.65	34.11	289	360	Peak

Remarks:

- Emission Level = Read Level + Antenna Factor + Cable Loss - Preamp Factor
Margin value = Emission level – Limit value
- 5530 MHz: Fundamental Frequency
- *: Out of Restricted Band

EUT Test Condition		Measurement Detail	
Channel	Channel 122	Frequency Range	1 GHz ~ 40 GHz
Input Power	120 Vac, 60 Hz	Detector Function	Peak (PK) Average (AV)
Environmental Conditions	25 deg. C, 65 % RH	Tested By	Karl Lee

Antenna Polarity & Test Distance: Horizontal at 3 m										
Frequency (MHz)	Emission Level (dBuV/m)	Read Level (dBuV)	Limit (dBuV/m)	Margin (dB)	Antenna Factor (dB/m)	Cable Loss (dB)	Preamp Factor (dB)	Antenna Height (cm)	Table Angle (Degree)	Remark
5450.96	43.88	35.06	54	-10.12	34.36	8.51	34.05	212	65	Average
5450.96	53.45	44.63	74	-20.55	34.36	8.51	34.05	212	65	Peak
*5468.88	52.77	43.94	68.2	-15.43	34.37	8.51	34.05	212	65	Peak
5610	90.74	81.71			34.5	8.61	34.08	212	65	Average
5610	97.9	88.87			34.5	8.61	34.08	212	65	Peak
*5724.76	53.03	43.87	68.2	-15.17	34.62	8.65	34.11	212	65	Peak

Antenna Polarity & Test Distance: Vertical at 3 m										
Frequency (MHz)	Emission Level (dBuV/m)	Read Level (dBuV)	Limit (dBuV/m)	Margin (dB)	Antenna Factor (dB/m)	Cable Loss (dB)	Preamp Factor (dB)	Antenna Height (cm)	Table Angle (Degree)	Remark
5360.88	43.67	35.03	54	-10.33	34.29	8.38	34.03	289	360	Average
5360.88	53.44	44.8	74	-20.56	34.29	8.38	34.03	289	360	Peak
*5468.88	52.78	43.95	68.2	-15.42	34.37	8.51	34.05	289	360	Peak
5610	81.78	72.75			34.5	8.61	34.08	289	360	Average
5610	88.89	79.86			34.5	8.61	34.08	289	360	Peak
*5724.68	52.73	43.57	68.2	-15.47	34.62	8.65	34.11	289	360	Peak

Remarks:

- Emission Level = Read Level + Antenna Factor + Cable Loss - Preamp Factor
Margin value = Emission level – Limit value
- 5610 MHz: Fundamental Frequency
- *: Out of Restricted Band

9 kHz ~ 30 MHz DATA:

The amplitude of spurious emissions attenuated more than 20 dB below the permissible value is not required to be report.

30 MHz ~ 1 GHz WORST-CASE DATA:

802.11ac (VHT80)

EUT Test Condition		Measurement Detail	
Channel	Channel 42	Frequency Range	30 MHz ~ 1 GHz
Input Power	120 Vac, 60 Hz	Detector Function	Peak (PK) Quasi-peak (QP)
Environmental Conditions	25 deg. C, 65 % RH	Tested By	Karl Lee

Antenna Polarity & Test Distance: Horizontal at 3 m										
Frequency (MHz)	Emission Level (dBuV/m)	Read Level (dBuV)	Limit (dBuV/m)	Margin (dB)	Antenna Factor (dB/m)	Cable Loss (dB)	Preamp Factor (dB)	Antenna Height (cm)	Table Angle (Degree)	Remark
59.97	9.36	27.32	40	-30.64	13.37	0.9	32.23	152	133	Peak
127.2	6.48	28.03	43.5	-37.02	9.31	1.38	32.24	175	144	Peak
240.33	11.11	29.29	46	-34.89	12.1	1.85	32.13	169	324	Peak
455.4	15.38	29.38	46	-30.62	15.65	2.49	32.14	106	316	Peak
664.7	18.8	29.26	46	-27.2	18.68	2.99	32.13	157	114	Peak
782.3	20.6	29.26	46	-25.4	20.16	3.27	32.09	128	154	Peak
Antenna Polarity & Test Distance: Vertical at 3 m										
Frequency (MHz)	Emission Level (dBuV/m)	Read Level (dBuV)	Limit (dBuV/m)	Margin (dB)	Antenna Factor (dB/m)	Cable Loss (dB)	Preamp Factor (dB)	Antenna Height (cm)	Table Angle (Degree)	Remark
54.84	15.83	33.02	40	-24.17	14.14	0.9	32.23	146	277	Peak
123.42	8	29.07	43.5	-35.5	9.79	1.38	32.24	169	121	Peak
251.13	11.52	29.34	46	-34.48	12.34	1.94	32.1	136	320	Peak
379.1	12.79	28.11	46	-33.21	14.58	2.26	32.16	189	125	Peak
669.6	18.94	29.26	46	-27.06	18.76	3.05	32.13	167	133	Peak
891.5	21.58	28.23	46	-24.42	21.4	3.49	31.54	105	224	Peak

Remarks:

1. Emission Level = Read Level + Antenna Factor + Cable Loss - Preamp Factor

Margin value = Emission level – Limit value

802.11a

EUT Test Condition		Measurement Detail	
Channel	Channel 64	Frequency Range	30 MHz ~ 1 GHz
Input Power	120 Vac, 60 Hz	Detector Function	Peak (PK) Quasi-peak (QP)
Environmental Conditions	25 deg. C, 65 % RH	Tested By	Karl Lee

Antenna Polarity & Test Distance: Horizontal at 3 m

Frequency (MHz)	Emission Level (dBuV/m)	Read Level (dBuV)	Limit (dBuV/m)	Margin (dB)	Antenna Factor (dB/m)	Cable Loss (dB)	Preamp Factor (dB)	Antenna Height (cm)	Table Angle (Degree)	Remark
91.83	9.36	29.15	43.5	-34.14	10.92	1.11	31.82	129	125	Peak
175.26	9.56	30.75	43.5	-33.94	9.44	1.61	32.24	137	126	Peak
272.46	13.54	31.05	46	-32.46	12.66	1.94	32.11	184	224	Peak
426.7	14.11	28.59	46	-31.89	15.29	2.41	32.18	127	65	Peak
726.3	19.64	29.02	46	-26.36	19.58	3.16	32.12	148	254	Peak
857.2	22.07	29.26	46	-23.93	21.12	3.44	31.75	129	341	Peak

Antenna Polarity & Test Distance: Vertical at 3 m

Frequency (MHz)	Emission Level (dBuV/m)	Read Level (dBuV)	Limit (dBuV/m)	Margin (dB)	Antenna Factor (dB/m)	Cable Loss (dB)	Preamp Factor (dB)	Antenna Height (cm)	Table Angle (Degree)	Remark
32.7	16.69	36.46	40	-23.31	11.74	0.74	32.25	131	125	Peak
113.43	8.56	27.99	43.5	-34.94	11.54	1.28	32.25	185	169	Peak
220.35	9.07	28.3	46	-36.93	11.34	1.65	32.22	174	112	Peak
346.2	13.24	28.96	46	-32.76	14.16	2.19	32.07	187	164	Peak
700.4	18.67	28.41	46	-27.33	19.24	3.11	32.09	131	256	Peak
787.9	20.13	28.73	46	-25.87	20.21	3.27	32.08	198	265	Peak

Remarks:

- Emission Level = Read Level + Antenna Factor + Cable Loss - Preamp Factor
Margin value = Emission level – Limit value

802.11a

EUT Test Condition		Measurement Detail	
Channel	Channel 100	Frequency Range	30 MHz ~ 1 GHz
Input Power	120 Vac, 60 Hz	Detector Function	Peak (PK) Quasi-peak (QP)
Environmental Conditions	25 deg. C, 65 % RH	Tested By	Karl Lee

Antenna Polarity & Test Distance: Horizontal at 3 m

Frequency (MHz)	Emission Level (dBuV/m)	Read Level (dBuV)	Limit (dBuV/m)	Margin (dB)	Antenna Factor (dB/m)	Cable Loss (dB)	Preamp Factor (dB)	Antenna Height (cm)	Table Angle (Degree)	Remark
66.99	8.32	28.33	40	-31.68	11.31	0.9	32.22	151	127	Peak
134.49	5.32	27.49	43.5	-38.18	8.7	1.38	32.25	165	294	Peak
233.04	11.81	30.27	46	-34.19	11.86	1.85	32.17	132	106	Peak
448.4	14.82	28.94	46	-31.18	15.54	2.49	32.15	147	187	Peak
632.5	16.96	27.96	46	-29.04	18.23	2.93	32.16	162	334	Peak
786.5	19.4	28.01	46	-26.6	20.2	3.27	32.08	169	101	Peak

Antenna Polarity & Test Distance: Vertical at 3 m

Frequency (MHz)	Emission Level (dBuV/m)	Read Level (dBuV)	Limit (dBuV/m)	Margin (dB)	Antenna Factor (dB/m)	Cable Loss (dB)	Preamp Factor (dB)	Antenna Height (cm)	Table Angle (Degree)	Remark
63.48	12.03	31.01	40	-27.97	12.35	0.9	32.23	161	108	Peak
109.11	9.42	28.36	43.5	-34.08	12.03	1.28	32.25	159	132	Peak
200.91	9.54	29.09	43.5	-33.96	11.09	1.65	32.29	105	129	Peak
414.1	13.59	28.22	46	-32.41	15.16	2.41	32.2	123	178	Peak
680.8	18.26	28.38	46	-27.74	18.94	3.05	32.11	165	359	Peak
808.2	20.71	28.96	46	-25.29	20.45	3.32	32.02	112	82	Peak

Remarks:

- Emission Level = Read Level + Antenna Factor + Cable Loss - Preamp Factor
Margin value = Emission level – Limit value

4.2 Conducted Emission Measurement

4.2.1 Limits of Conducted Emission Measurement

Frequency (MHz)	Conducted Limit (dBuV)	
	Quasi-peak	Average
0.15 - 0.5	66 - 56	56 - 46
0.50 - 5.0	56	46
5.0 - 30.0	60	50

Note: 1. The lower limit shall apply at the transition frequencies.

2. The limit decreases in line with the logarithm of the frequency in the range of 0.15 to 0.50 MHz.

4.2.2 Test Instruments

Description & Manufacturer	Model No.	Serial No.	Date Of Calibration	Due Date Of Calibration
Test Receiver ROHDE & SCHWARZ	ESCS 30	100288	Aug.17, 2017	Aug. 16, 2018
RF signal cable (with 10dB PAD) Woken	5D-FB	Cable-cond2-01	Sep. 09, 2017	Sep. 08, 2018
LISN/AMN ROHDE & SCHWARZ (EUT)	ESH2-Z5	100100	Jan. 17, 2017	Jan. 16, 2018
LISN/AMN ROHDE & SCHWARZ (Peripheral)	ESH3-Z5	100312	Aug. 02, 2017	Aug. 01, 2018
Software ADT	BV ADT_Cond_ V7.3.7.3	NA	NA	NA

Note: 1. The calibration interval of the above test instruments is 12 months and the calibrations are traceable to NML/ROC and NIST/USA.

2. The test was performed in HwaYa Shielded Room 2.

3. The VCCI Site Registration No. is C-2047.

4.2.3 Test Procedures

- a. The EUT was placed 0.4 meters from the conducting wall of the shielded room with EUT being connected to the power mains through a line impedance stabilization network (LISN). Other support units were connected to the power mains through another LISN. The two LISNs provide 50 ohm/ 50uH of coupling impedance for the measuring instrument.
- b. Both lines of the power mains connected to the EUT were checked for maximum conducted interference.
- c. The frequency range from 150 kHz to 30 MHz was searched. Emission levels under (Limit -20 dB) was not recorded.

Note: All modes of operation were investigated and the worst-case emissions are reported.

4.2.4 Deviation from Test Standard

No deviation.

4.2.5 Test Setup

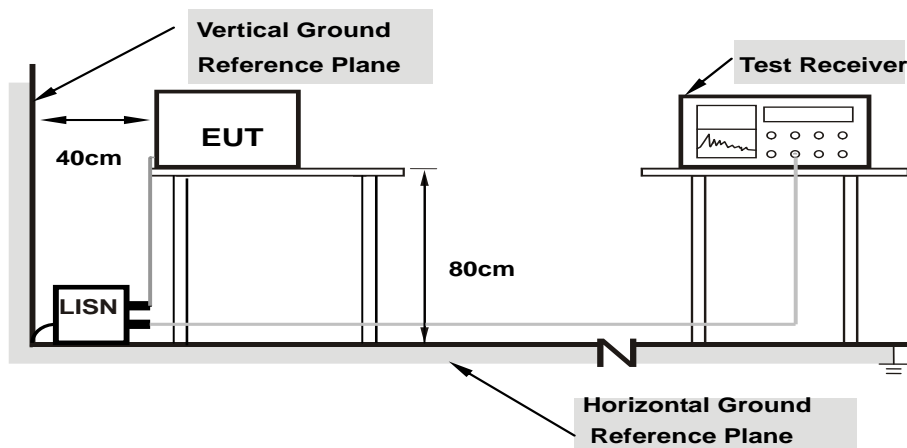

- Note:**
- 1.Support units were connected to second LISN.
 - 2.Both of LISNs (AMN) are 80 cm from EUT and at least 80 from other units and other metal planes

For the actual test configuration, please refer to the attached file (Test Setup Photo).

4.2.6 EUT Operating Conditions

- a. Placed the EUT on a testing table.
- b. Use the software to control the EUT under transmission condition continuously at specific channel frequency.

4.2.7 Test Results

Frequency Range	150kHz ~ 30MHz	Detector Function & Resolution Bandwidth	Quasi-Peak (QP) / Average (AV), 9kHz
Input Power	120Vac, 60Hz	Environmental Conditions	25°C, 65%RH
Tested by	Getaz Yang	Test Date	2017/9/13

Phase Of Power : Line (L)										
No	Frequency (MHz)	Correction Factor (dB)	Reading Value (dBuV)		Emission Level (dBuV)		Limit (dBuV)		Margin (dB)	
			Q.P.	AV.	Q.P.	AV.	Q.P.	AV.	Q.P.	AV.
1	0.21250	10.32	23.44	10.28	33.76	20.60	63.11	53.11	-29.35	-32.51
2	0.57969	10.33	29.84	22.61	40.17	32.94	56.00	46.00	-15.83	-13.06
3	1.33594	10.40	18.41	11.05	28.81	21.45	56.00	46.00	-27.19	-24.55
4	2.43750	10.39	21.21	13.91	31.60	24.30	56.00	46.00	-24.40	-21.70
5	3.35156	10.44	25.46	14.85	35.90	25.29	56.00	46.00	-20.10	-20.71
6	4.03125	10.47	24.01	10.67	34.48	21.14	56.00	46.00	-21.52	-24.86

Remarks:

1. Q.P. and AV. are abbreviations of quasi-peak and average individually.
2. The emission levels of other frequencies were very low against the limit.
3. Margin value = Emission level – Limit value
4. Correction factor = Insertion loss + Cable loss
5. Emission Level = Correction Factor + Reading Value

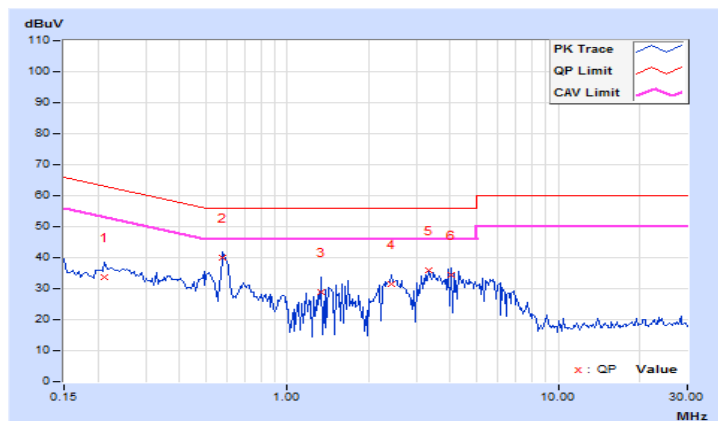

Frequency Range	150kHz ~ 30MHz	Detector Function & Resolution Bandwidth	Quasi-Peak (QP) / Average (AV), 9kHz
Input Power	120Vac, 60Hz	Environmental Conditions	25°C, 65%RH
Tested by	Getaz Yang	Test Date	2017/9/13

Phase Of Power : Neutral (N)										
No	Frequency (MHz)	Correction Factor (dB)	Reading Value (dBuV)		Emission Level (dBuV)		Limit (dBuV)		Margin (dB)	
			Q.P.	AV.	Q.P.	AV.	Q.P.	AV.	Q.P.	AV.
1	0.16562	10.26	20.91	4.33	31.17	14.59	65.18	55.18	-34.01	-40.59
2	0.21641	10.21	21.31	4.11	31.52	14.32	62.96	52.96	-31.44	-38.64
3	0.58359	10.33	23.60	10.86	33.93	21.19	56.00	46.00	-22.07	-24.81
4	3.29297	10.53	6.99	-0.72	17.52	9.81	56.00	46.00	-38.48	-36.19
5	5.35938	10.58	7.08	-3.40	17.66	7.18	60.00	50.00	-42.34	-42.82
6	14.19531	10.69	11.30	-7.97	21.99	2.72	60.00	50.00	-38.01	-47.28

Remarks:

1. Q.P. and AV. are abbreviations of quasi-peak and average individually.
2. The emission levels of other frequencies were very low against the limit.
3. Margin value = Emission level – Limit value
4. Correction factor = Insertion loss + Cable loss
5. Emission Level = Correction Factor + Reading Value

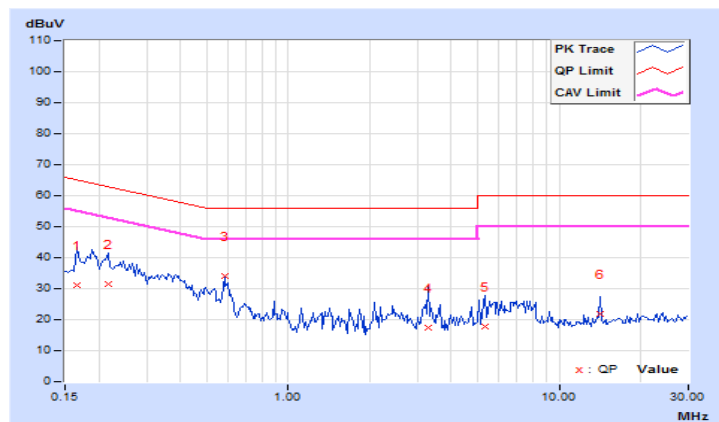

4.3 Transmit Power Measurement

4.3.1 Limits of Transmit Power Measurement

Operation Band	EUT Category	Limit
U-NII-1	Outdoor Access Point	1 Watt (30 dBm) (Max. e.i.r.p \leq 125 mW (21 dBm) at any elevation angle above 30 degrees as measured from the horizon)
	Fixed point-to-point Access Point	1 Watt (30 dBm)
	Indoor Access Point	1 Watt (30 dBm)
	√ Mobile and Portable client device	250 mW (24 dBm)
U-NII-2A	√	250 mW (24 dBm) or 11 dBm+10 log B*
U-NII-2C	√	250 mW (24 dBm) or 11 dBm+10 log B*
U-NII-3		1 Watt (30 dBm)

*B is the 26 dB emission bandwidth in megahertz

Per KDB 662911 Method of conducted output power measurement on IEEE 802.11 devices,

Array Gain = 0 dB (i.e., no array gain) for $N_{ANT} \leq 4$;

Array Gain = 0 dB (i.e., no array gain) for channel widths ≥ 40 MHz for any N_{ANT} ;

Array Gain = $5 \log(N_{ANT}/N_{SS})$ dB or 3 dB, whichever is less for 20 MHz channel widths with $N_{ANT} \geq 5$.

For power measurements on all other devices: Array Gain = $10 \log(N_{ANT}/N_{SS})$ dB.

4.3.2 Test Setup

<Power Output Measurement>

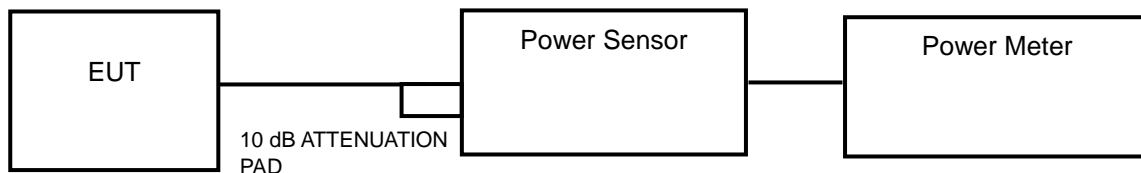

or

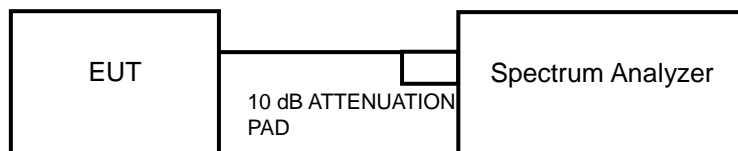

<26 dB Bandwidth>

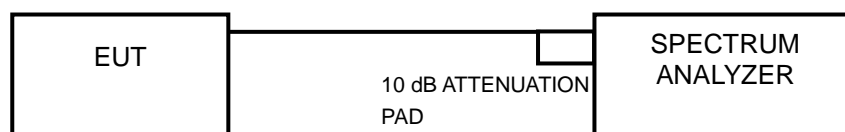

4.3.3 Test Instruments

Refer to section 4.1.2 to get information of above instrument.

4.3.4 Test Procedure

Average Power Measurement

<802.11a, 802.11n (HT20), 802.11n (HT40)>

Method PM is used to perform output power measurement, trigger and gating function of wide band power meter is enabled to measure max output power of TX on burst. Duty factor is not added to measured value.

<802.11ac (VHT80)>

Method SA-1 is used to perform output power measurement, trigger and gating function of spectrum analyzer is enabled to measure max output power of TX on burst. Duty factor is not added to measured value.

26 dB Bandwidth

- 1) Set RBW = approximately 1 % of the emission bandwidth.
- 2) Set the VBW > RBW.
- 3) Detector = Peak.
- 4) Trace mode = max hold.
- 5) Measure the maximum width of the emission that is 26 dB down from the peak of the emission. Compare this with the RBW setting of the analyzer. Readjust RBW and repeat measurement as needed until the RBW/EBW ratio is approximately 1 %.

4.3.5 Deviation from Test Standard

No deviation.

4.3.6 EUT Operating Conditions

The software provided by client to enable the EUT under transmission condition continuously at lowest, middle and highest channel frequencies individually.

4.3.7 Test Result

Power Output:

802.11a

Channel	Frequency (MHz)	Maximum Conducted Power (mW)	Maximum Conducted Power (dBm)	Power Limit (dBm)	Pass / Fail
36	5180	2.723	4.35	24	Pass
44	5220	2.518	4.01	24	Pass
48	5240	2.547	4.06	24	Pass
52	5260	2.576	4.11	24	Pass
60	5300	2.748	4.39	24	Pass
64	5320	2.606	4.16	24	Pass
100	5500	2.844	4.54	24	Pass
116	5580	2.951	4.70	24	Pass
140	5700	2.805	4.48	24	Pass

Note:

For U-NII-2A, U-NII-2C Band:

1. $11 \text{ dBm} + 10\log(22.41) = 24.5 \text{ dBm} > 24 \text{ dBm}$.
2. $11 \text{ dBm} + 10\log(22.20) = 24.46 \text{ dBm} > 24 \text{ dBm}$.
3. $11 \text{ dBm} + 10\log(22.79) = 24.57 \text{ dBm} > 24 \text{ dBm}$.
4. $11 \text{ dBm} + 10\log(22.76) = 24.57 \text{ dBm} > 24 \text{ dBm}$.
5. $11 \text{ dBm} + 10\log(22.53) = 24.52 \text{ dBm} > 24 \text{ dBm}$.
6. $11 \text{ dBm} + 10\log(22.29) = 24.48 \text{ dBm} > 24 \text{ dBm}$.

802.11n (HT20)

Channel	Frequency (MHz)	Maximum Conducted Power (dBm)		Total Power (mW)	Total Power (dBm)	Power Limit (dBm)	Pass / Fail
		Chain 0	Chain 1				
36	5180	5.47	3.80	5.923	7.73	24	Pass
44	5220	5.54	4.13	6.169	7.90	24	Pass
48	5240	4.47	3.85	5.226	7.18	24	Pass
52	5260	5.81	3.90	6.266	7.97	24	Pass
60	5300	5.21	3.97	5.814	7.64	24	Pass
64	5320	5.62	4.31	6.346	8.03	24	Pass
100	5500	4.46	4.80	5.813	7.64	24	Pass
116	5580	4.53	5.63	6.494	8.13	24	Pass
140	5700	4.71	5.19	6.262	7.97	24	Pass

Note:

For U-NII-2A, U-NII-2C Band:

Chain 0

1. $11 \text{ dBm} + 10\log (24.13) = 24.82 \text{ dBm} > 24 \text{ dBm}$.
2. $11 \text{ dBm} + 10\log (23.41) = 24.69 \text{ dBm} > 24 \text{ dBm}$.
3. $11 \text{ dBm} + 10\log (24.09) = 24.81 \text{ dBm} > 24 \text{ dBm}$.
4. $11 \text{ dBm} + 10\log (23.21) = 24.65 \text{ dBm} > 24 \text{ dBm}$.
5. $11 \text{ dBm} + 10\log (24.13) = 24.82 \text{ dBm} > 24 \text{ dBm}$.
6. $11 \text{ dBm} + 10\log (23.39) = 24.69 \text{ dBm} > 24 \text{ dBm}$.

Chain 1

1. $11 \text{ dBm} + 10\log (23.55) = 24.71 \text{ dBm} > 24 \text{ dBm}$.
2. $11 \text{ dBm} + 10\log (23.34) = 24.68 \text{ dBm} > 24 \text{ dBm}$.
3. $11 \text{ dBm} + 10\log (23.42) = 24.69 \text{ dBm} > 24 \text{ dBm}$.
4. $11 \text{ dBm} + 10\log (23.46) = 24.65 \text{ dBm} > 24 \text{ dBm}$.
5. $11 \text{ dBm} + 10\log (23.42) = 24.69 \text{ dBm} > 24 \text{ dBm}$.
6. $11 \text{ dBm} + 10\log (24.15) = 24.69 \text{ dBm} > 24 \text{ dBm}$.

802.11n (HT40)

Channel	Frequency (MHz)	Maximum Conducted Power (dBm)		Total Power (mW)	Total Power (dBm)	Power Limit (dBm)	Pass / Fail
		Chain 0	Chain 1				
38	5190	6.13	3.39	6.285	7.98	24	Pass
46	5230	5.88	3.93	6.345	8.02	24	Pass
54	5270	5.79	4.12	6.375	8.04	24	Pass
62	5310	5.43	4.47	6.29	7.99	24	Pass
102	5510	4.23	5.37	6.092	7.85	24	Pass
110	5550	4.18	5.45	6.126	7.87	24	Pass
134	5670	4.74	5.74	6.729	8.28	24	Pass

Note:

For U-NII-2A, U-NII-2C Band:

Chain 0

1. $11 \text{ dBm} + 10\log(41.82) = 27.21 \text{ dBm} > 24 \text{ dBm}$.
2. $11 \text{ dBm} + 10\log(42.01) = 27.23 \text{ dBm} > 24 \text{ dBm}$.
3. $11 \text{ dBm} + 10\log(41.85) = 27.21 \text{ dBm} > 24 \text{ dBm}$.
4. $11 \text{ dBm} + 10\log(42.05) = 27.23 \text{ dBm} > 24 \text{ dBm}$.
5. $11 \text{ dBm} + 10\log(42.05) = 27.23 \text{ dBm} > 24 \text{ dBm}$.

Chain 1

1. $11 \text{ dBm} + 10\log(42.15) = 27.24 \text{ dBm} > 24 \text{ dBm}$.
2. $11 \text{ dBm} + 10\log(42.07) = 27.23 \text{ dBm} > 24 \text{ dBm}$.
3. $11 \text{ dBm} + 10\log(42.08) = 27.24 \text{ dBm} > 24 \text{ dBm}$.
4. $11 \text{ dBm} + 10\log(42.16) = 27.24 \text{ dBm} > 24 \text{ dBm}$.
5. $11 \text{ dBm} + 10\log(41.85) = 27.21 \text{ dBm} > 24 \text{ dBm}$.

802.11ac (VHT80)

Channel	Frequency (MHz)	Maximum Conducted Power (dBm)		Total Power (mW)	Total Power (dBm)	Power Limit (dBm)	Pass / Fail
		Chain 0	Chain 1				
42	5210	6.06	4.31	6.734	8.28	24	Pass
58	5290	5.14	3.93	5.738	7.59	24	Pass
106	5530	4.09	5.37	6.007	7.79	24	Pass
122	5610	4.14	5.84	6.431	8.08	24	Pass

Note:

For U-NII-2A, U-NII-2C Band:

Chain 0

1. $11 \text{ dBm} + 10\log (84.11) = 30.24 \text{ dBm} > 24 \text{ dBm}.$
2. $11 \text{ dBm} + 10\log (83.93) = 30.23 \text{ dBm} > 24 \text{ dBm}.$
3. $11 \text{ dBm} + 10\log (83.69) = 30.22 \text{ dBm} > 24 \text{ dBm}.$

Chain 1

1. $11 \text{ dBm} + 10\log (83.16) = 30.19 \text{ dBm} > 24 \text{ dBm}.$
2. $11 \text{ dBm} + 10\log (83.03) = 30.19 \text{ dBm} > 24 \text{ dBm}.$
3. $11 \text{ dBm} + 10\log (82.88) = 30.18 \text{ dBm} > 24 \text{ dBm}.$

26 dB Bandwidth:
802.11a

Channel	Frequency (MHz)	26 dBc Bandwidth (MHz)
36	5180	22.87
44	5220	22.28
48	5240	22.87
52	5260	22.41
60	5300	22.20
64	5320	22.79
100	5500	22.76
116	5580	22.53
140	5700	22.29

802.11n (HT20)

Channel	Frequency (MHz)	26 dBc Bandwidth (MHz)	
		Chain 0	Chain 1
36	5180	24.08	23.56
44	5220	23.17	23.47
48	5240	23.66	23.53
52	5260	24.13	23.55
60	5300	23.41	23.34
64	5320	24.09	23.42
100	5500	23.21	23.46
116	5580	24.13	23.42
140	5700	23.39	24.15

802.11n (HT40)

Channel	Frequency (MHz)	26 dBc Bandwidth (MHz)	
		Chain 0	Chain 1
38	5190	42.08	42.15
46	5230	41.86	42.13
54	5270	41.82	42.15
62	5310	42.01	42.07
102	5510	41.85	42.08
110	5550	42.05	42.16
134	5670	42.05	41.85

802.11ac (VHT80)

Channel	Frequency (MHz)	26 dBc Bandwidth (MHz)	
		Chain 0	Chain 1
42	5210	83.43	82.79
58	5290	84.11	83.16
106	5530	83.93	83.03
122	5610	83.69	82.88

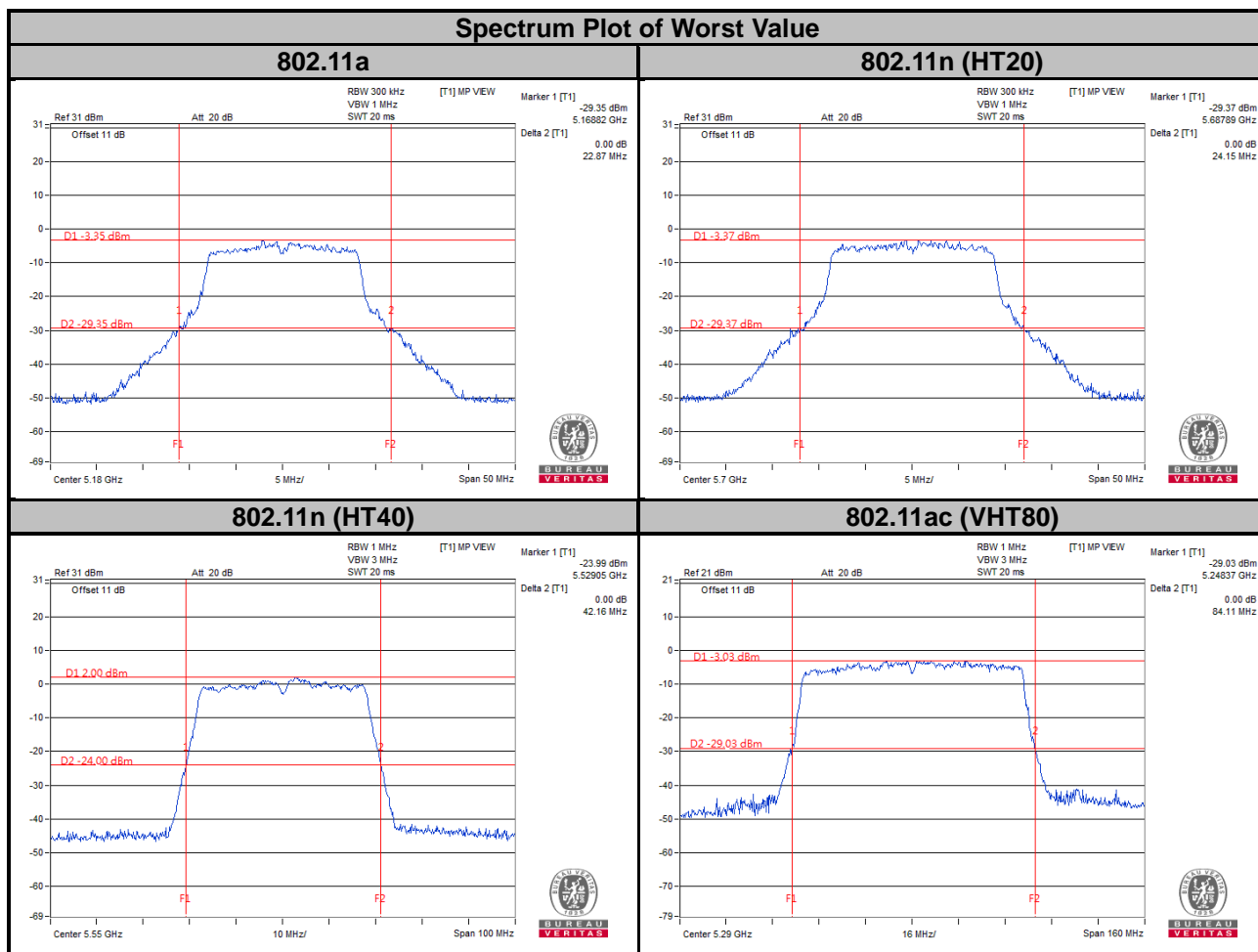

4.4 Occupied Bandwidth Measurement

4.4.1 Test Setup

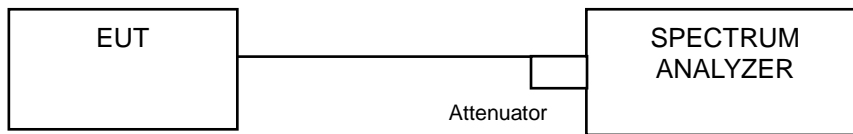

4.4.2 Test Instruments

Refer to section 4.1.2 to get information of above instrument.

4.4.3 Test Procedure

The transmitter output was connected to the spectrum analyzer through an attenuator. The bandwidth of the fundamental frequency was measured by spectrum analyzer with resolution bandwidth in the range of 1 % to 5 % of the anticipated emission bandwidth, and a video bandwidth at least 3x the resolution bandwidth and set the detector to SAMPLE. The width of a frequency band such that, below the lower and above the upper frequency limits, the mean powers emitted are each equal to a specified percentage 0.5 % of the total mean power of a given emission.

4.4.4 Test Results

802.11a

Channel	Channel Frequency (MHz)	Occupied Bandwidth (MHz)
36	5180	16.77
40	5200	16.73
48	5240	16.77
52	5260	16.77
60	5300	16.77
64	5320	16.77
100	5500	16.77
116	5580	16.73
140	5700	16.77

802.11n (HT20)

Channel	Channel Frequency (MHz)	Occupied Bandwidth (MHz)	
		Chain 0	Chain 1
36	5180	17.93	17.93
40	5200	17.88	17.88
48	5240	17.98	17.88
52	5260	17.98	17.88
60	5300	17.88	17.88
64	5320	17.98	17.88
100	5500	17.88	17.88
116	5580	17.98	17.83
140	5700	17.88	17.93

802.11n (HT40)

Channel	Channel Frequency (MHz)	Occupied Bandwidth (MHz)	
		Chain 0	Chain 1
38	5190	36.66	36.66
46	5230	36.66	36.66
54	5270	36.66	36.66
62	5310	36.66	36.66
102	5510	36.66	36.53
110	5550	36.66	36.53
134	5670	36.66	36.53

802.11ac (VHT80)

Channel	Channel Frequency (MHz)	Occupied Bandwidth (MHz)	
		Chain 0	Chain 1
42	5210	75.80	75.80
58	5290	75.96	75.96
106	5530	75.96	75.96
122	5610	75.80	75.80

Spectrum Plot of Worst Value

802.11a

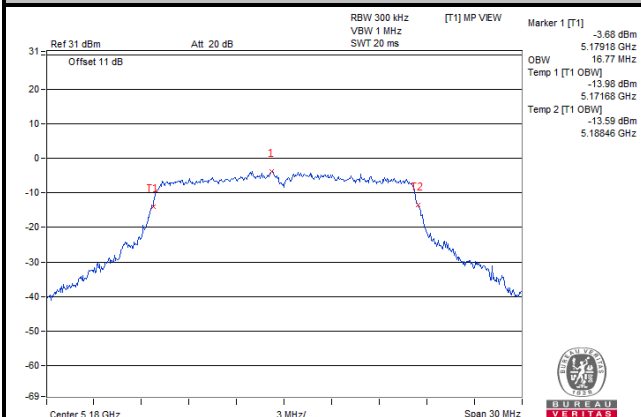

802.11n (HT20)

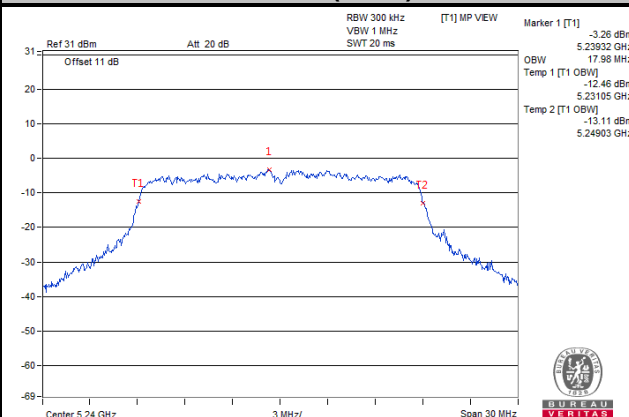

802.11n (HT40)

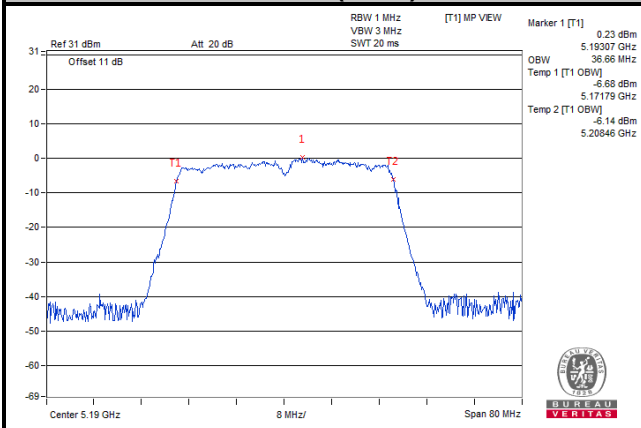

802.11ac (VHT80)

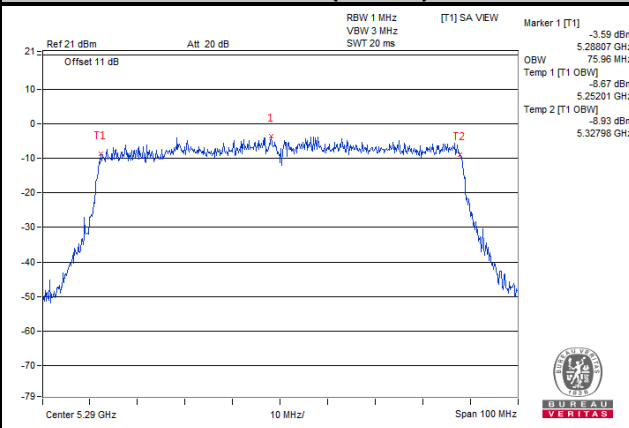

4.5 Peak Power Spectral Density Measurement

4.5.1 Limits of Peak Power Spectral Density Measurement

Operation Band	EUT Category		Limit
U-NII-1		Outdoor Access Point	17 dBm/MHz
		Fixed point-to-point Access Point	
		Indoor Access Point	
	√	Mobile and Portable client device	11 dBm/MHz
U-NII-2A		√	11 dBm/MHz
U-NII-2C		√	11 dBm/MHz
U-NII-3		-	30 dBm/500 kHz

4.5.2 Test Setup

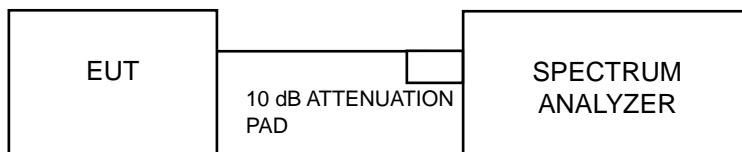

4.5.3 Test Instruments

Refer to section 4.1.3 to get information of above instrument.

4.5.4 Test Procedures

For U-NII-1, U-NII-2A, U-NII-2C band:

Using method SA-2

1. Set span to encompass the entire emission bandwidth (EBW) of the signal.
2. Set RBW = 1 MHz, Set VBW \geq 3 RBW, Detector = RMS
3. Sweep time = auto, trigger set to "free run".
4. Trace average at least 100 traces in power averaging mode.
5. Record the max value and add 10 log (1/duty cycle)

※For U-NII-3:

1. Set span to encompass the entire emission bandwidth (EBW) of the signal.
2. Set RBW = 500 kHz, Set VBW \geq 3 RBW, Detector = RMS
3. Use the peak marker function to determine the maximum power level in any 500 kHz band segment within the fundamental EBW.
4. Sweep time = auto, trigger set to "free run".
5. Trace average at least 100 traces in power averaging mode.
6. Record the max value and add 10 log (1/duty cycle)

4.5.5 Deviation from Test Standard

No deviation.

4.5.6 EUT Operating Conditions

The software provided by client to enable the EUT under transmission condition continuously at lowest, middle and highest channel frequencies individually.

4.5.7 Test Results

For U-NII-1, U-NII-2A, U-NII-2C Band

802.11a

Channel	Frequency (MHz)	PSD w/o Duty Factor (dBm/MHz)	Duty Factor (dB)	PSD with Duty Factor (dBm/MHz)	Maximum Limit (dBm/MHz)	Pass / Fail
36	5180	-7.17	0.27	-6.91	11	Pass
44	5220	-6.82	0.27	-6.56	11	Pass
48	5240	-6.94	0.27	-6.68	11	Pass
52	5260	-6.85	0.27	-6.59	11	Pass
60	5300	-6.53	0.27	-6.27	11	Pass
64	5320	-6.25	0.27	-5.99	11	Pass
100	5500	-4.96	0.27	-4.70	11	Pass
116	5580	-5.51	0.27	-5.25	11	Pass
140	5700	-7.07	0.27	-6.81	11	Pass

Note: Refer to section 3.3 for duty cycle spectrum plot.

802.11n (HT20)

Channel	Frequency (MHz)	PSD (dBm/MHz)		Duty Factor (dB)	Total PSD with Duty Factor (dBm/MHz)	Max. Limit (dBm/MHz)	Pass / Fail
		Chain 0	Chain 1				
36	5180	-6.49	-7.90	0.29	-3.84	11	Pass
44	5220	-6.72	-7.76	0.29	-3.91	11	Pass
48	5240	-7.05	-7.82	0.29	-4.12	11	Pass
52	5260	-6.73	-7.88	0.29	-3.97	11	Pass
60	5300	-6.15	-7.27	0.29	-3.38	11	Pass
64	5320	-6.49	-6.99	0.29	-3.44	11	Pass
100	5500	-4.97	-5.38	0.29	-1.87	11	Pass
116	5580	-6.54	-5.41	0.29	-2.64	11	Pass
140	5700	-6.67	-6.85	0.29	-3.46	11	Pass

Note:

- Method 1 of power density measurement of KDB 662911 is using for calculating total power density. Total power density is summing entire spectra across corresponding frequency bins on the various outputs by computer.
- Directional gain = $10\log[(10^{G1/20} + 10^{G2/20})^2 / N_{ANT}] = 1.38 \text{ dBi} < 6 \text{ dBi}$, so the limit no need to reduced.
- Refer to section 3.3 for duty cycle spectrum plot.

802.11n (HT40)

Channel	Frequency (MHz)	PSD (dBm/MHz)		Duty Factor (dB)	Total PSD with Duty Factor (dBm/MHz)	Max. Limit (dBm/MHz)	Pass / Fail
		Chain 0	Chain 1				
38	5190	-9.68	-11.18	0.59	-6.77	11	Pass
46	5230	-9.55	-10.71	0.59	-6.49	11	Pass
54	5270	-9.27	-10.91	0.59	-6.41	11	Pass
62	5310	-9.05	-10.29	0.59	-6.03	11	Pass
102	5510	-8.65	-8.47	0.59	-4.96	11	Pass
110	5550	-8.42	-8.18	0.59	-4.70	11	Pass
134	5670	-10.41	-9.45	0.59	-6.30	11	Pass

Note:

1. Method 1 of power density measurement of KDB 662911 is using for calculating total power density. Total power density is summing entire spectra across corresponding frequency bins on the various outputs by computer.
2. Directional gain = $10\log[(10^{G1/20} + 10^{G2/20})^2 / N_{ANT}] = 1.38 \text{ dBi} < 6 \text{ dBi}$, so the limit no need to reduced.
3. Refer to section 3.3 for duty cycle spectrum plot.

802.11ac (VHT80)

Channel	Frequency (MHz)	PSD (dBm/MHz)		Duty Factor (dB)	Total PSD with Duty Factor (dBm/MHz)	Max. Limit (dBm/MHz)	Pass / Fail
		Chain 0	Chain 1				
42	5210	-13.28	-14.79	0.97	-9.99	11	Pass
58	5290	-13.15	-14.36	0.97	-9.73	11	Pass
106	5530	-12.83	-12.27	0.97	-8.56	11	Pass
122	5610	-13.75	-13.25	0.97	-9.51	11	Pass

Note:

1. Method 1 of power density measurement of KDB 662911 is using for calculating total power density. Total power density is summing entire spectra across corresponding frequency bins on the various outputs by computer.
2. Directional gain = $10\log[(10^{G1/20} + 10^{G2/20})^2 / N_{ANT}] = 1.38 \text{ dBi} < 6 \text{ dBi}$, so the limit no need to reduced.
3. Refer to section 3.3 for duty cycle spectrum plot.

Spectrum Plot of Worst Value

802.11a

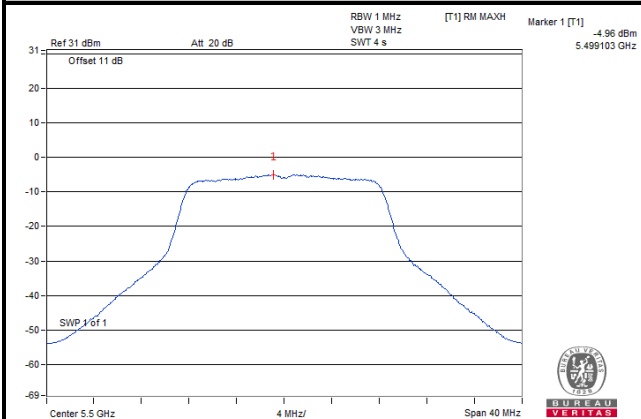

802.11n (HT20)

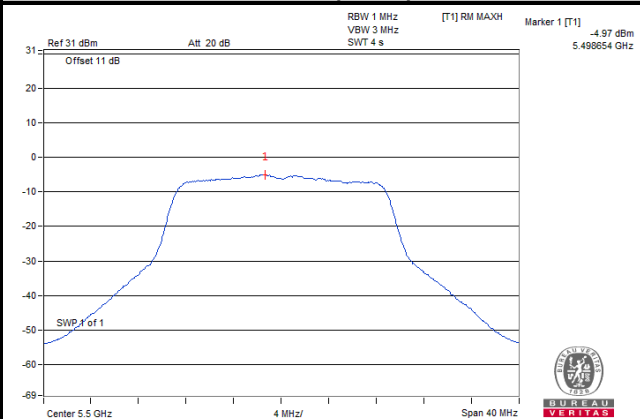

802.11n (HT40)

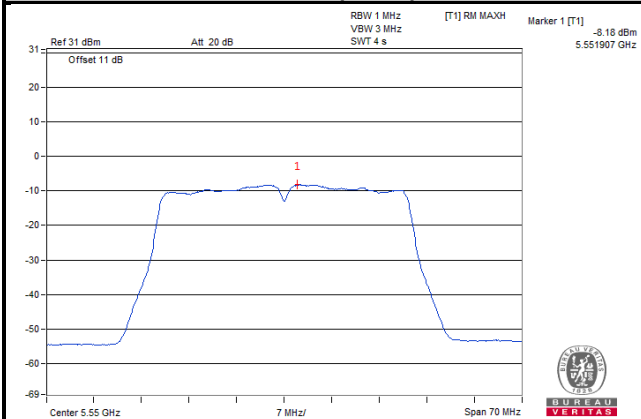

802.11ac (VHT80)

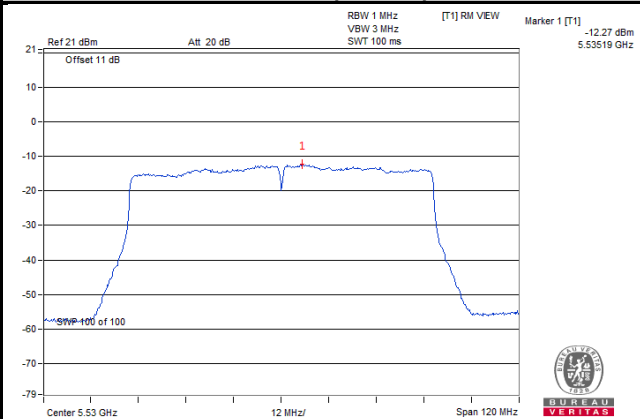

4.6 Frequency Stability

4.6.1 Limit of Frequency Stability Measurement

The frequency of the carrier signal shall be maintained within band of operation.

4.6.2 Test Setup

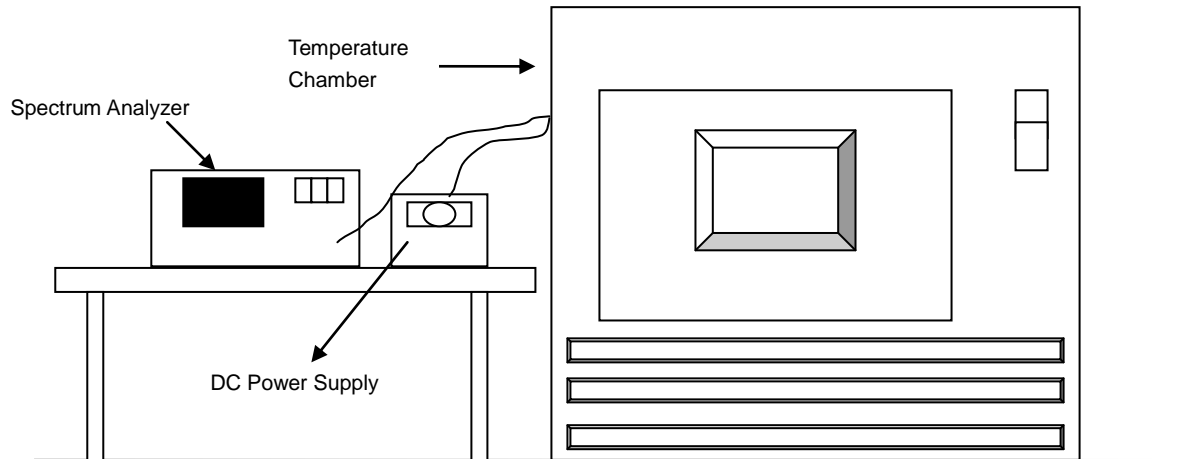

4.6.3 Test Instruments

Refer to section 4.1.3 to get information of above instrument.

4.6.4 Test Procedure

- To ensure emission at the band edge is maintained within the authorized band, those values shall be measured by radiation emissions at upper and lower frequency points, and finally compensated by frequency deviation as procedures below.
- The EUT was operated at the maximum output power, and connected to the spectrum analyzer, which is set to maximum hold function and peak detector. The peak value of the power envelope was measured and noted. The upper and lower frequency points were respectively measured relatively 10 dB lower than the measured peak value.
- The frequency deviation was calculated by adding the upper frequency point and the lower frequency point divided by two. Those detailed values of frequency deviation are provided in table below.

4.6.5 Deviation from Test Standard

No deviation.

4.6.6 EUT Operating Condition

Set the EUT transmit at un-modulation mode to test frequency stability.

4.6.7 Test Results

Frequency Stability Versus Temp.									
Operating Frequency: 5320 MHz									
Temp. (°C)	Power Supply (Vdc)	0 Minute		2 Minute		5 Minute		10 Minute	
		Measured Frequency (MHz)	Frequency Drift (ppm)	Measured Frequency (MHz)	Frequency Drift (ppm)	Measured Frequency (MHz)	Frequency Drift (ppm)	Measured Frequency (MHz)	Frequency Drift (ppm)
50	3.8	5180.0243	4.69000	5180.0253	4.88000	5180.0231	4.46000	5180.0258	4.98000
40	3.8	5179.9894	-2.05000	5179.988	-2.32000	5179.9887	-2.18000	5179.9912	-1.70000
30	3.8	5180.0205	3.96000	5180.0162	3.13000	5180.0192	3.71000	5180.0202	3.90000
20	3.8	5180.0258	4.98000	5180.0254	4.90000	5180.0266	5.14000	5180.025	4.83000
10	3.8	5180.016	3.09000	5180.019	3.67000	5180.0191	3.69000	5180.0164	3.17000
0	3.8	5179.9743	-4.96000	5179.9761	-4.61000	5179.9745	-4.92000	5179.9777	-4.31000
-10	3.8	5180.0234	4.52000	5180.0266	5.14000	5180.0248	4.79000	5180.0233	4.50000
-20	3.8	5179.9927	-1.41000	5179.99	-1.93000	5179.9915	-1.64000	5179.9889	-2.14000
-30	3.8	5179.9873	-2.45000	5179.9842	-3.05000	5179.9867	-2.57000	5179.9878	-2.36000

Frequency Stability Versus Temp.									
Operating Frequency: 5320 MHz									
Temp. (°C)	Power Supply (Vdc)	0 Minute		2 Minute		5 Minute		10 Minute	
		Measured Frequency (MHz)	Frequency Drift (ppm)	Measured Frequency (MHz)	Frequency Drift (ppm)	Measured Frequency (MHz)	Frequency Drift (ppm)	Measured Frequency (MHz)	Frequency Drift (ppm)
20	4.485	5180.0251	4.85000	5180.0263	5.08000	5180.0265	5.12000	5180.0243	4.69000
	3.8	5180.0258	4.98000	5180.0254	4.90000	5180.0266	5.14000	5180.025	4.83000
	3.315	5180.0254	4.90000	5180.0258	4.98000	5180.026	5.02000	5180.025	4.83000

5 Pictures of Test Arrangements

Please refer to the attached file (Test Setup Photo).

Appendix – Information on the Testing Laboratories

We, Bureau Veritas Consumer Products Services (H.K.) Ltd., Taoyuan Branch, were founded in 1988 to provide our best service in EMC, Radio, Telecom and Safety consultation. Our laboratories are FCC recognized accredited test firms and accredited according to ISO/IEC 17025.

If you have any comments, please feel free to contact us at the following:

Linko EMC/RF Lab

Tel: 886-2-26052180

Fax: 886-2-26051924

Hsin Chu EMC/RF/Telecom Lab

Tel: 886-3-6668565

Fax: 886-3-6668323

Hwa Ya EMC/RF/Safety

Tel: 886-3-3183232

Fax: 886-3-3270892

Email: service.adt@tw.bureauveritas.com

Web Site: www.bureauveritas-adt.com

The address and road map of all our labs can be found in our web site also.

--- END ---