

TEST REPORT

For

Mobile Phone

In conformity with

FCC Part15B (01 Oct, 2008)

Model: F-02B
FCC ID: VQK-F02B
Test Item: Mobile Phone
Report No: RY0908P12R3
Issue Date: 12 Aug, 2009

Prepared for

Fujitsu Limited.
4-1-1, Kamikodanaka, Nakahara, Kawasaki 211-8588, Japan

Prepared by

RF Technologies Ltd.
472, Nippa-cho, Kohoku-ku, Yokohama, 223-0057, Japan
Telephone: +81+(0)45- 534-0645
FAX: +81+(0)45- 534-0646

This report shall not be reproduced, except in full, without the written permission of RF Technologies Ltd. The test results in this report apply only to the sample(s) tested. RF Technologies Ltd. is managed to ISO17025 and has the necessary knowledge and test facilities for testing according to the referenced standards.

Table of Contents

1	General information	3
1.1	Product description	3
1.2	Test(s) performed/ Summary of test result	3
1.3	Test facility	4
1.4	Measurement uncertainty	4
1.5	Description of essential requirements and test results.....	5
1.5.1	Test requirements (FCC Part15B).....	5
1.5.2	Normal test conditions	5
1.6	Setup of equipment under test (EUT)	6
1.6.1	Test configuration of EUT	6
1.6.2	Operating condition:	6
1.6.3	Setup diagram of tested system:.....	6
1.7	Equipment modifications	7
1.8	Deviation from the standard.....	7
2	Test procedure and result.....	8
2.1	Radiated Emissions	8
2.2	AC power line conducted emissions	11
3	Test setup photographs.....	13
4	List of utilized test equipment/ calibration.....	14

History

Report No.	Issue Date	Revision Contents	Issued by
RY0908P12R3	12 Aug, 2009	Initial Issue	T.Kato

1 General information

1.1 Product description

Test item : Mobile phone
Manufacturer : Fujitsu Limited
Address : 4-1-1, Kamikodanaka, Nakahara, Kawasaki, 211-8588, Japan
Model : F-02B
FCC ID : VQK-F02B
Description : WCDMA850/GSM1900 Mobile Phone
Operating Frequency : 48MHz (Max)
Receipt date of EUT : 27 July, 2009
Nominal power voltages : 3.7VDC (Lithium-ion battery)
Serial numbers : 3567 7402 0004 495

1.2 Test(s) performed/ Summary of test result

Applicable Standard(s) : Part15 Subpart B (01 Oct,2008)
Test(s) started : 12 Aug, 2009
Test(s) completed : 12 Aug, 2009
Purpose of test(s) : Grant for Certification of FCC

Summary of test result : Complied

Note: The above judgment is only based on the measurement data and it does not include the measurement uncertainty. Accordingly, the statement below is applied to the test result. The EUT complies with the limit required in the standard in case that the margin is not less than the measurement uncertainty in the Laboratory. Compliance of the EUT is more probable than non-compliance is case that the margin is less than the measurement uncertainty in the Laboratory.

Test engineer : 
T. Kato (Engineer, EMC Testing Department)

Reviewer : 
K. Ohnishi (Manager, EMC Testing Department)

1.3 Test facility

The Federal Communications Commission has reviewed the technical characteristics of the test facilities at RF Technologies Ltd., located in 472, Nippa-cho, Kohoku-ku, Yokohama, 223-0057, Japan, and has found these test facilities to be in compliance with the requirements of 47 CFR Part 15, section 2.948, per 01 October, 2008.

The description of the test facilities has been filed under registration number 319924 at the Office of the Federal Communications Commission. The facility has been added to the list of laboratories performing these test services for the public on a fee basis.

The list of all public test facilities is available on the Internet at <http://www.fcc.gov>.

Registered by Voluntary Control Council for Interference by Information Technology Equipment (VCCI).

Each registered facility number is as follows;

Test site (Semi-anechoic chamber 3m) R-2393

Test site (Shielded room) C-2617

Registered by Industry Canada (IC). The registered facility number is as follows;

Test site No.1(Semi-anechoic chamber 3m) : 6974A-1

Accredited by **National Voluntary Laboratory Accreditation Program** (NVLAP) for the emission tests stated in the scope of the certificate under Certificate Number 200780-0

This report must not be used by the client to claim product certification, approval, or endorsement by NVLAP, NIST, or any agency of the Federal Government.



NVLAP LAB CODE 200780-0

1.4 Measurement uncertainty

The treatment of uncertainty is based on the general matters on the definition of uncertainty in “Guide to the expression of uncertainty in measurement (GUM)” published by ISO. The Lab’s uncertainty is determined by referring UKAS Publication LAB34: 2002 “The Expression of Uncertainty in EMC Testing” and CISPR16-4-2: 2003 “Uncertainty in EMC Measurements”.

The uncertainty of the measurement result in the level of confidence of approximately 95% (k=2) is as follows;

RF frequency : $\pm 1 \times 10^{-7}$

RF conducted level : ± 1.0 dB

AC Power line emission : ± 1.9 dB

Radiated emission (30MHz - 1000MHz) : ± 5.7 dB

Radiated emission (above 1000MHz) : ± 5.8 dB

Temperature : ± 1 degree

Humidity : ± 5 %

1.5 Description of essential requirements and test results

An overview of test requirements, as laid out in FCC Part15B are given below.

1.5.1 Test requirements (FCC Part15B)

Test Description	Section in this report	Applicable	Result
Radiated emission (15.109)	2.1	Yes	Passed
AC power line conducted emission (15.107)	2.2	Yes	Passed

1.5.2 Normal test conditions

Temperature(*) : +15 degC to +35 degC
Relative humidity(*) : 20 % to 75 %
Supply voltage : 3.7 VDC (Nominal)

1.6 Setup of equipment under test (EUT)

1.6.1 Test configuration of EUT

Equipment(s):

	Item	Manufacturer	Model No.	Serial No.	FCC ID/
A	Mobile phone (EUT)	Fujitsu Limited	F-02B	3567 7402 0004 495	VQK-F02B
B	Battery pack	Fujitsu Limited	F09	-	N/A
C	Notebook PC	TOSHIBA	PP410J0001G1	13513107	DoC
D	AC Adapter	TOSHIBA	PA3262U-1ACA	0212A0005779G	DoC
E	Mouse	TOSHIBA	G83C0001Y110	LZE30201086	DoC

Connected cable(s):

No.	Item	Identification (Manu.e.t.c)	Shielded YES / NO	Ferrite Core YES / NO	Connector Type Shielded YES / NO	Length (m)
1	USB cable	NTT DOCOMO, INC.	No	No	Yes	0.7
2	DC power cable	TOSHIBA	No	No	No	1.8
3	AC power cable	-	No	No	No	1.5
4	Mouse cable	-	No	No	No	0.8

1.6.2 Operating condition:

Mobile phone was connected to Notebook PC with USB cable.

With this condition, emission level was tested during USB data communication.

1.6.3 Setup diagram of tested system:

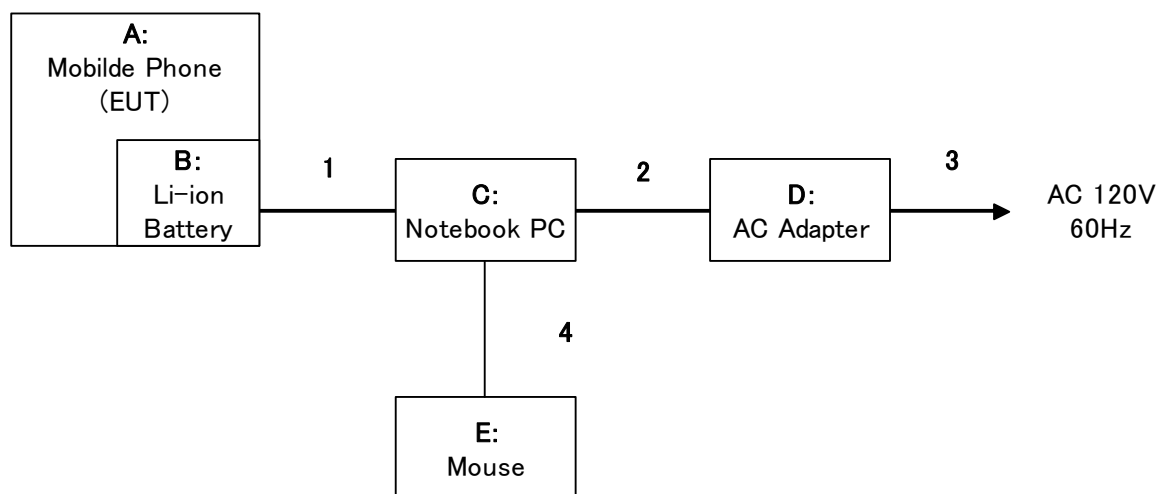

1.7 *Equipment modifications*

No modifications have been made to the equipment in order to achieve compliance with the applicable standards described in clause 1.2.

1.8 *Deviation from the standard*

No deviations from the standards described in clause 1.2.

2 Test procedure and result

2.1 Radiated Emissions

Reference Standard

Part15.109

Test Conditions

Date: 12 Aug, 2009
Ambient Temperature: 20 degC
Relative humidity: 62 %
Test Voltage: 3.7 V

Test Method

- Test data is transmitted from EUT to Notebook PC with USB cable.
- Radiated spurious emission is received by receive antenna.
- Turn table is rotated 360deg.
- Maximum level of each spurious is measured by Test receiver.
- RBW of spectrum analyzer is set to 100kHz for 30 - 1000MHz, or 1MHz for above 1000MHz.
- Level is measured with QP detect for 30 - 1000MHz, or AVE detector for above 1000MHz.

Test Setup

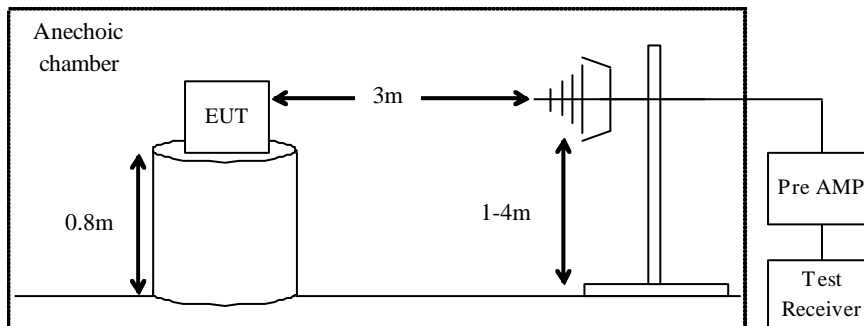

Limit

Frequency (MHz)	Distance (m)	Field strength (uV/m)	Field strength (dBuV/m)
30 - 88	3	100	40.0
88 - 216	3	150	43.5
216 - 960	3	200	46.0
above 960	3	500	53.9

Test Results

Frequency [MHz]	Antenna	Reading [dBuV]	Factor [dB/m]	Loss [dB]	Gain [dB]	Field strength [dBuV/m]	Limit [dBuV/m]	Result
60.000	Hori.	47.6	6.6	7.8	29.6	32.4	40.0	Passed
65.478	Hori.	47.6	6.4	7.8	29.6	32.2	40.0	Passed
67.056	Hori	43.2	6.4	7.9	29.6	27.9	40.0	Passed
72.000	Hori	48.4	6.4	7.9	29.6	33.1	40.0	Passed
76.399	Hori	40.0	6.8	8.0	29.6	25.2	40.0	Passed
204.000	Hori	44.8	9.5	9.5	29.5	34.4	43.5	Passed
216.000	Hori	50.9	9.6	9.6	29.5	41.3	43.5	Passed
455.193	Hori	38.3	13.7	13.7	29.7	39.1	46.0	Passed
480.000	Hori	39.3	14.4	14.4	29.7	41.3	46.0	Passed
715.301	Hori	33.3	13.3	13.3	29.5	36.4	46.0	Passed
910.388	Hori	33.6	14.2	14.2	28.9	39.5	46.0	Passed
39.704	Vert.	36.4	13.2	7.5	29.7	27.4	40.0	Passed
60.000	Vert.	45.2	6.6	7.8	29.6	30.0	40.0	Passed
77.661	Vert	37.0	6.8	8.0	29.6	22.2	40.0	Passed
195.082	Vert	43.4	9.2	9.4	29.5	32.5	43.5	Passed
390.165	Vert	33.5	15.6	12.0	29.7	31.4	46.0	Passed
455.194	Vert	39.4	16.8	13.7	29.7	40.2	46.0	Passed
480.000	Vert	36.6	17.3	14.4	29.7	38.6	46.0	Passed
520.221	Vert	33.1	17.9	14.5	29.7	35.8	46.0	Passed
910.387	Vert	36.0	20.6	14.2	28.9	41.9	46.0	Passed
927.000	Vert	25.6	20.8	14.2	28.7	31.9	46.0	Passed

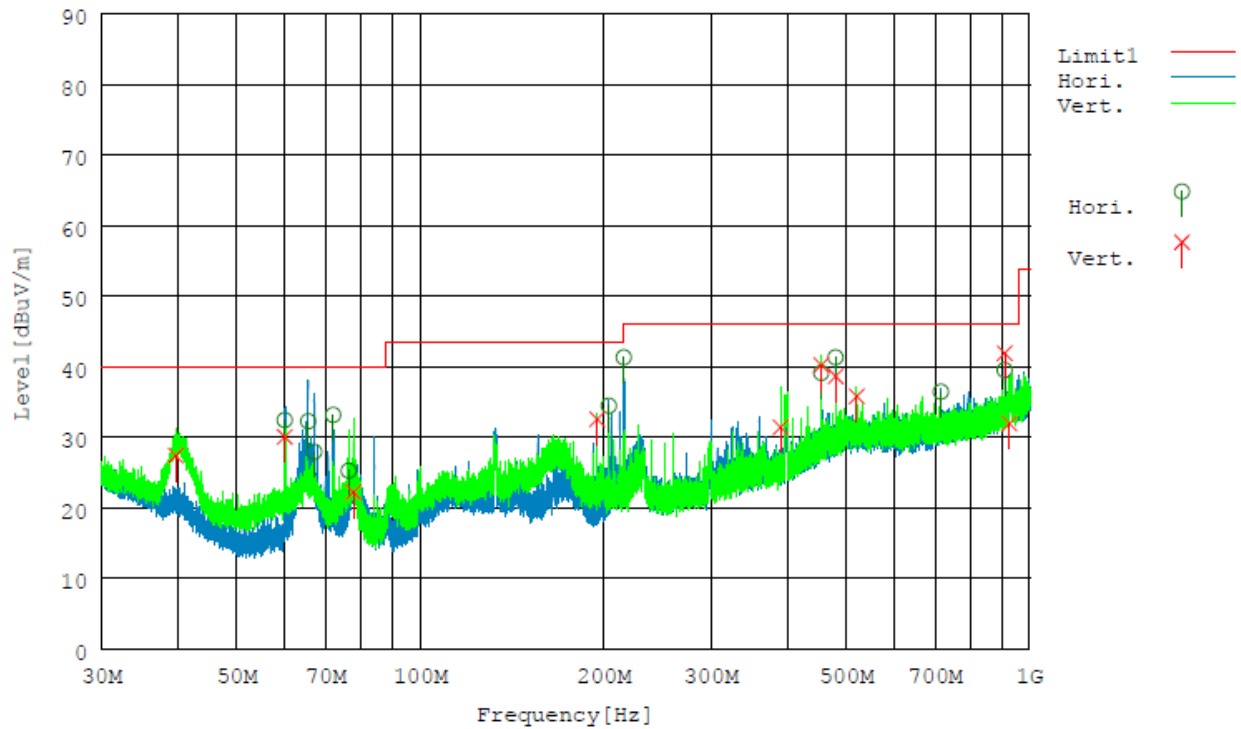

Test Equipment Used

Equipment name	RFT ID No.
RF cable	CL11
Receive Antenna	BA04
Pre AMP	PR03
Test Receiver	TR04

Final Result

The EUT met the requirements of the standard for this test.

2.2 AC power line conducted emissions

Reference Standard

FCC : Part15.107

Test Conditions

Date: 12 Aug, 2009
 Ambient Temperature: 20 degC
 Relative humidity: 62 %
 Test Voltage: 3.7 V

Test Method

- Test data is transmitted from EUT to Notebook PC with USB cable.
- AC power is supplied to AC charger through LISN.
- AC charger is connected to EUT.
- AC Power Line emission is measured by EMI receiver.
 - Both Va/Vb line are measured emission level.

Test Setup

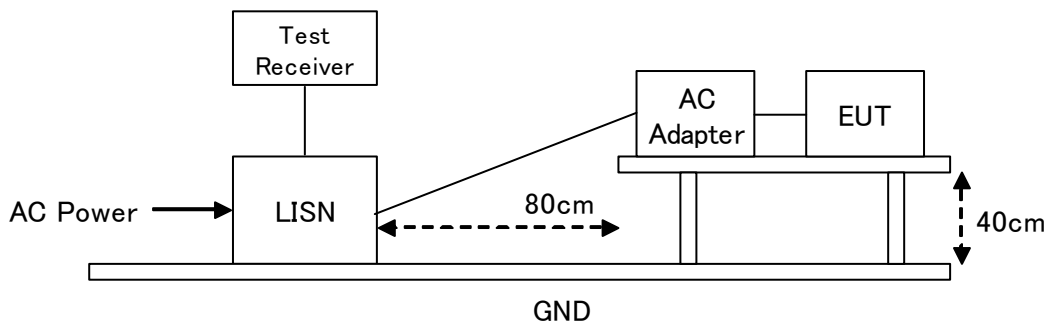

Limit

Frequency (MHz)	Limit QP (dBuV)	Limit AV (dBuV)
0.15 - 0.5	66 - 56	56 - 46
0.5 - 5	56	46
5 - 30	60	50

Test Results

Frequency [MHz]	Line [Va/Vb]	QP Reading [dBuV]	AVE Reading [dBuV]	Factor [dB]	QP Result [dBuV]	AVE Result [dBuV]	QP Limit [dBuV]	AVE Limit [dBuV]	Result
0.150	Va	51.4	41.5	0.3	51.7	41.8	66.0	56.0	Passed
0.307	Va	33.2	25.7	0.2	33.4	25.9	60.1	50.1	Passed
6.543	Va	36.8	31.5	0.7	37.5	32.2	60.0	50.0	Passed
0.150	Vb	52.1	42.4	0.3	52.4	42.7	66.0	56.0	Passed
0.306	Vb	37.3	26.8	0.2	37.5	27.0	60.1	50.1	Passed
6.621	Vb	36.2	31.0	0.7	36.9	31.7	60.0	50.0	Passed

Graphical Data

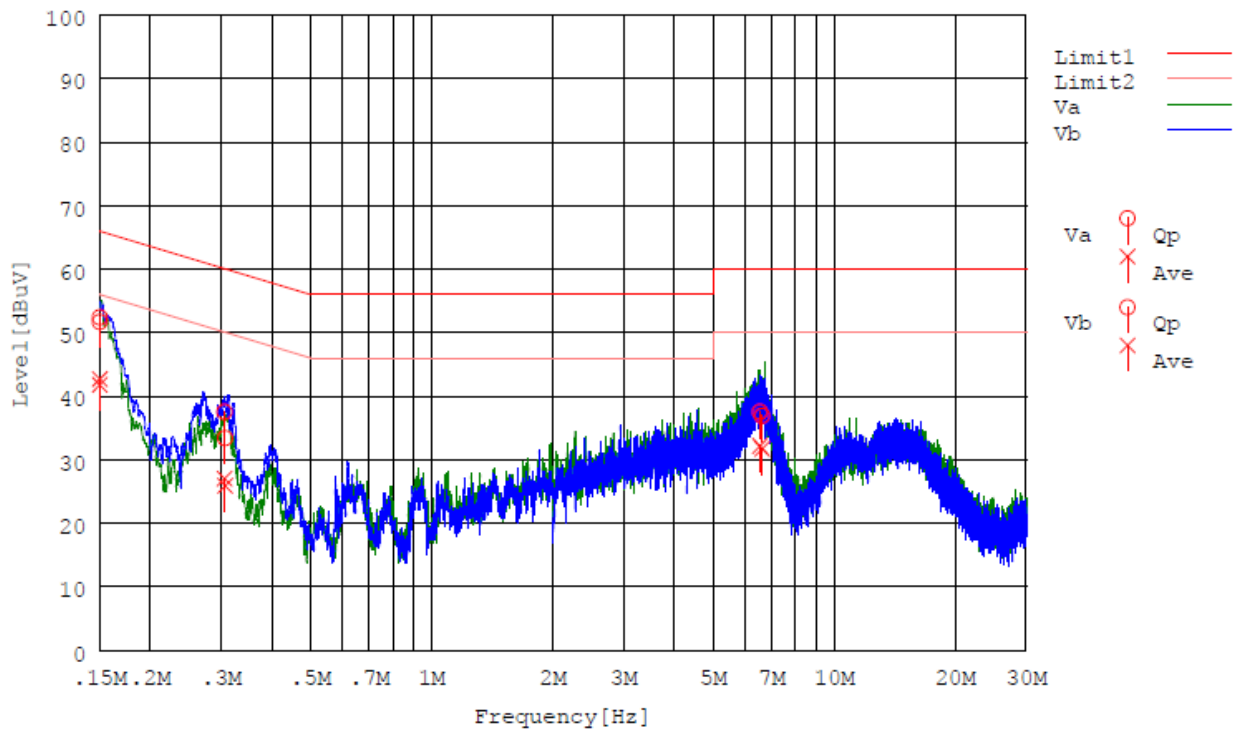

Equipment name	RFT ID No.
EMI Receiver	TR04
LISN	LN06
RF cable	CL11

Final Result

The EUT met the requirements of the standard for this test

4 List of utilized test equipment/ calibration

RFT ID No.	Kind of Equipment and Precision	Manufacturer	Model No.	Serial Number	Calibration Date	Calibrated until
AC01	Anechoic Chamber (1st test room)	JSE	203397C	-	2009/4/9	2010/4/30
BA04	Biological Antenna	SCHAFFNER	CA2855	2903	2009/1/6	2010/1/31
CL11	Antenna Cable for RE	RFT	-	-	2009/4/13	2010/4/30
LN06	LISN	Kyoritsu	KNW-407	8-1773-3	2009/5/26	2010/5/31
PR03	Pre. Amplifier	Anritsu	MH648A	M41984	2009/5/26	2010/5/31
TR04	Test Receiver (F/W : 3.82 SP1)	Rohde & Schwarz	ESCI	100447	2008/9/16	2009/9/30

The measuring equipment, which was utilized in performing the tests documented herein, has been calibrated in accordance with the manufacturer's recommendations for utilizing calibration equipment, which is traceable to recognized national standards.