

TEST REPORT

For

Mobile Phone

In conformity with

**FCC Part15B (Oct 01,2007)
IC ICES-003 Issue4**

Model: F-04A

Test Item: Mobile Phone

Report No: RY0810P21R2

Issue Date: Oct. 21, 2008

Prepared for

Fujitsu Limited.
1-1, Kamikodanaka 4-chome, Nakahara-ku, Kawasaki 211-8588,
Japan

Prepared by

RF Technologies Ltd.
472, Nippa-cho, Kohoku-ku, Yokohama, 223-0057, Japan
Telephone: +81+(0)45- 534-0645
FAX: +81+(0)45- 534-0646

This report shall not be reproduced, except in full, without the written permission of RF Technologies Ltd. The test results in this report apply only to the sample(s) tested. RF Technologies Ltd. is managed to ISO17025 and has the necessary knowledge and test facilities for testing according to the referenced standards.

Table of Contents

1	General information	3
1.1	Product description	3
1.2	Test(s) performed/ Summary of test result	3
1.3	Test facility	4
1.4	Measurement uncertainty	4
1.5	Description of essential requirements and test results.....	5
1.5.1	Test requirements (FCC Part15B/ICES-003)	5
1.5.2	Normal test conditions	5
1.6	Setup of equipment under test (EUT)	6
1.6.1	Test configuration of EUT	6
1.6.2	Operating condition:	6
1.6.3	Setup diagram of tested system:.....	6
1.7	Equipment modifications	7
1.8	Deviation from the standard.....	7
2	Test procedure and result.....	8
2.1	Radiated Emissions	8
2.2	AC power line conducted emissions	11
3	Test setup photographs.....	13
4	List of utilized test equipment/ calibration.....	14

1 General information

1.1 Product description

Test item : Mobile phone
Manufacturer : Fujitsu Limited
Address : 1-1, Kamikodanaka 4-chome, Nakahara-ku, Kawasaki
211-8588, Japan
Model : F-04A
FCC ID : VQK-F-04A
IC Certification No. : 337E-F04A
Description : WCDMA850 Mobile Phone
Receipt date of EUT : Oct.17, 2008
Nominal power voltages : 3.7VDC (Lithium-ion battery)
Serial numbers : 3537 0902 0001 193

1.2 Test(s) performed/ Summary of test result

Applicable Standard(s) : Part15 Subpart B(Oct 01,2007)
ICES-003 Issue4
Test(s) started : Oct.20, 2008
Test(s) completed : Oct.20, 2008
Purpose of test(s) : Grant for Certification of FCC/IC
Summary of test result : Complied

Note: The above judgment is only based on the measurement data and it does not include the measurement uncertainty. Accordingly, the statement below is applied to the test result. The EUT complies with the limit required in the standard in case that the margin is not less than the measurement uncertainty in the Laboratory. Compliance of the EUT is more probable than non-compliance is case that the margin is less than the measurement uncertainty in the Laboratory.

Test engineer

: 
T. Kato (EMC Testing Department)

Reviewer

: 
T. Ikegami (Manager, EMC Testing Department)

1.3 Test facility

The Federal Communications Commission has reviewed the technical characteristics of the test facilities at RF Technologies Ltd., located in 472, Nippa-cho, Kohoku-ku, Yokohama, 223-0057, Japan, and has found these test facilities to be in compliance with the requirements of 47 CFR Part 15, section 2.948, per October 01, 2007.

The description of the test facilities has been filed under registration number 879401 at the Office of the Federal Communications Commission. The facility has been added to the list of laboratories performing these test services for the public on a fee basis.

The list of all public test facilities is available on the Internet at <http://www.fcc.gov>.

Registered by Voluntary Control Council for Interference by Information Technology Equipment (VCCI).

Each registered facility number is as follows;

Test site (Semi-anechoic chamber 3m) R-2393

Test site (Shielded room) C-2617

Registered by Industry Canada (IC). The registered facility number is as follows;

Test site No.1(Semi-anechoic chamber 3m) : 6974A-1

1.4 Measurement uncertainty

The treatment of uncertainty is based on the general matters on the definition of uncertainty in “Guide to the expression of uncertainty in measurement (GUM)” published by ISO. The Lab’s uncertainty is determined by referring UKAS Publication LAB34: 2002 “The Expression of Uncertainty in EMC Testing” and CISPR16-4-2: 2003 “Uncertainty in EMC Measurements”. The uncertainty of the measurement result in the level of confidence of approximately 95% (k=2) is as follows;

RF frequency : $\pm 1 \times 10^{-7}$

RF conducted level : ± 1.0 dB

AC Power line emission : ± 1.9 dB

Radiated emission (30MHz - 1000MHz) : ± 5.7 dB

Radiated emission (above 1000MHz) : ± 5.8 dB

Temperature : ± 1 degree

Humidity : ± 5 %

1.5 Description of essential requirements and test results

An overview of test requirements, as laid out in FCC Part15B/ICES-003 are given below.

1.5.1 Test requirements (FCC Part15B/ICES-003)

Test Description	Section in this report	Applicable	Result
Radiated emission (15.109)	2.1	Yes	Passed
AC power line conducted emission (15.107)	2.2	Yes	Passed

1.5.2 Normal test conditions

Temperature(*) : +15 degC to +35 degC
Relative humidity(*) : 20 % to 75 %
Supply voltage : 3.7 VDC (Nominal)

1.6 Setup of equipment under test (EUT)

1.6.1 Test configuration of EUT

Equipment(s) under test:

	Item	Manufacturer	Model No.	Serial No.	FCC ID/
A	Mobile phone	Fujitsu Limited	F-04A	353709020001193	VQK-F-04A/ 337E-F04A
B	Battery pack	Fujitsu Limited	CA54310-0005	None	N/A
C	Notebook PC	TOSHIBA	PP410J0001G1	13513107	N/A
D	AC Adapter	TOSHIBA	PA3262U-1ACA	0212A0005779G	N/A
E	Mouse	TOSHIBA	G83C0001Y110	LZE30201086	N/A

Connected cable(s):

No.	Item	Identification (Manu.e.t.c)	Shielded YES / NO	Ferrite Core YES / NO	Connector Type Shielded YES / NO	Length (m)
1	USB cable	NTT DOCOMO, INC.	No	No	Yes	0.7
2	DC power cable	TOSHIBA	No	No	No	1.8
3	AC power cable	-	No	No	No	1.5
4	Mouse cable	-	No	No	No	0.8

1.6.2 Operating condition:

Mobile phone was connected to Notebook PC with USB cable.

With this condition, emission level was tested during USB data communication.

1.6.3 Setup diagram of tested system:

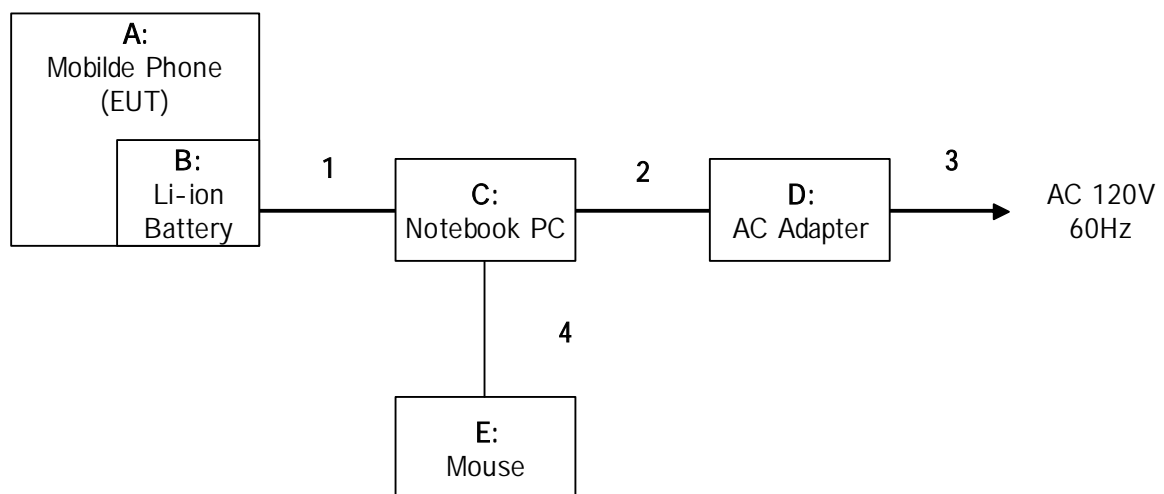

1.7 *Equipment modifications*

No modifications have been made to the equipment in order to achieve compliance with the applicable standards described in clause 1.2.

1.8 *Deviation from the standard*

No deviations from the standards described in clause 1.2.

2 Test procedure and result

2.1 Radiated Emissions

Reference Standard

Part15.109

Test Conditions

Date: 2008/10/20
Ambient Temperature: 20 degC
Relative humidity: 62 %
Test Voltage: 3.7 V

Test Method

- Test data is transmitted from EUT to Notebook PC with USB cable.
- Radiated spurious emission is received by receive antenna.
- Turn table is rotated 360deg.
- Maximum level of each spurious is measured by Test receiver.
- RBW of spectrum analyzer is set to 100kHz for 30 - 1000MHz.
- Level is measured with QP detect for 30 - 1000MHz.

Test Setup

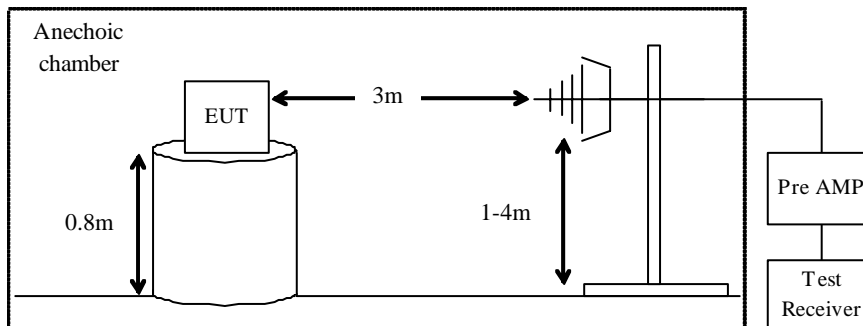

Limit

Frequency (MHz)	Distance (m)	Field strength (uV/m)	Field strength (dBuV/m)
30 - 88	3	100	40.0
88 - 216	3	150	43.5
216 - 960	3	200	46.0
above 960	3	500	54.0

Test Results

Frequency (MHz)	Antenna	Field strength (dBuV/m)	Limit (dBuV/m)	Result
30.751	Vert	30.0	40.0	Passed
60.000	Vert	25.9	40.0	Passed
165.729	Vert	26.9	43.5	Passed
400.213	Vert	38.4	46.0	Passed
455.194	Vert	43.9	46.0	Passed
520.222	Vert	45.3	46.0	Passed
60.000	Hori	32.6	40.0	Passed
66.000	Hori	27.7	40.0	Passed
133.023	Hori	31.2	43.5	Passed
395.996	Hori	31.1	46.0	Passed
715.305	Hori	37.4	46.0	Passed

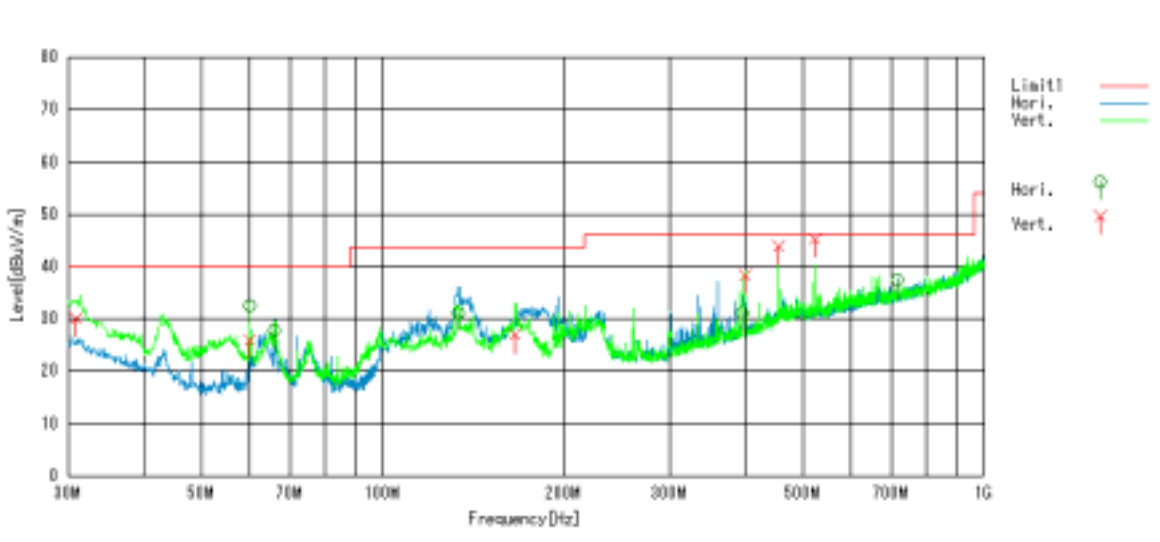

Test Equipment Used

Equipment name	RFT ID No.
RF cable	CL11
Receive Antenna	BA03
Pre AMP	PR03
Test Receiver	TR06

Final Result

The EUT met the requirements of the standard for this test.

2.2 AC power line conducted emissions

Reference Standard

FCC : Part15.107

Test Conditions

Date: 2008/10/20
 Ambient Temperature: 20 degC
 Relative humidity: 62 %
 Test Voltage: 3.7 V

Test Method

- Test data is transmitted from EUT to Notebook PC with USB cable.
- AC power is supplied to AC charger through LISN.
- AC charger is connected to EUT.
- AC Power Line emission is measured by EMI receiver.
 Both Live/Neutral is measured emission level.

Test Setup

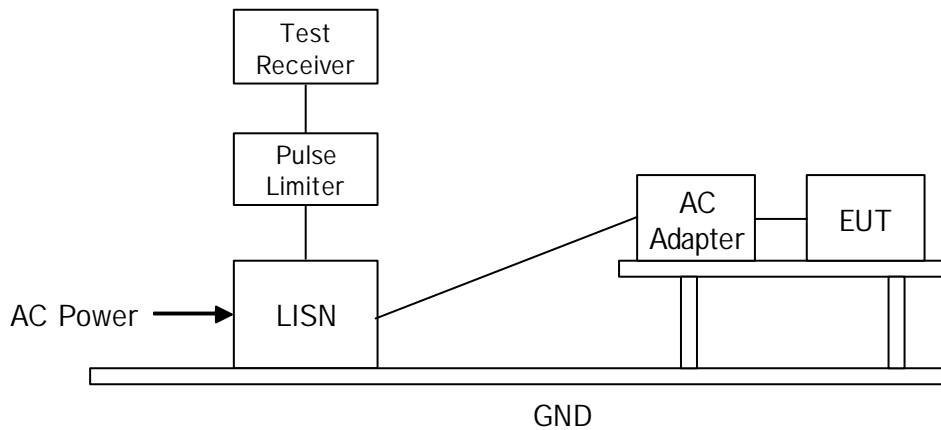

Limit

Frequency (MHz)	Limit QP (dBuV)	Limit AV (dBuV)
0.15 - 0.5	66 - 56	56 - 46
0.5 - 5	56	46
5 - 30	60	50

Test Results

Frequency (MHz)	Line (Live/Neutral)	QP Level (dBuV)	AVE Level (dBuV)	QP Limit (dBuV)	AVE Limit (dBuV)	Result
0.150	Live	53.0	41.4	66.0	56.0	Passed
0.223	Live	26.1	17.2	62.7	52.7	Passed
0.261	Live	41.7	29.8	61.4	51.4	Passed
6.605	Live	34.3	27.6	60.0	50.0	Passed
0.150	Neutral	53.1	39.9	66.0	56.0	Passed
0.271	Neutral	40.0	27.0	61.1	51.1	Passed
6.672	Neutral	33.4	27.6	60.0	50.0	Passed

Graphical Data

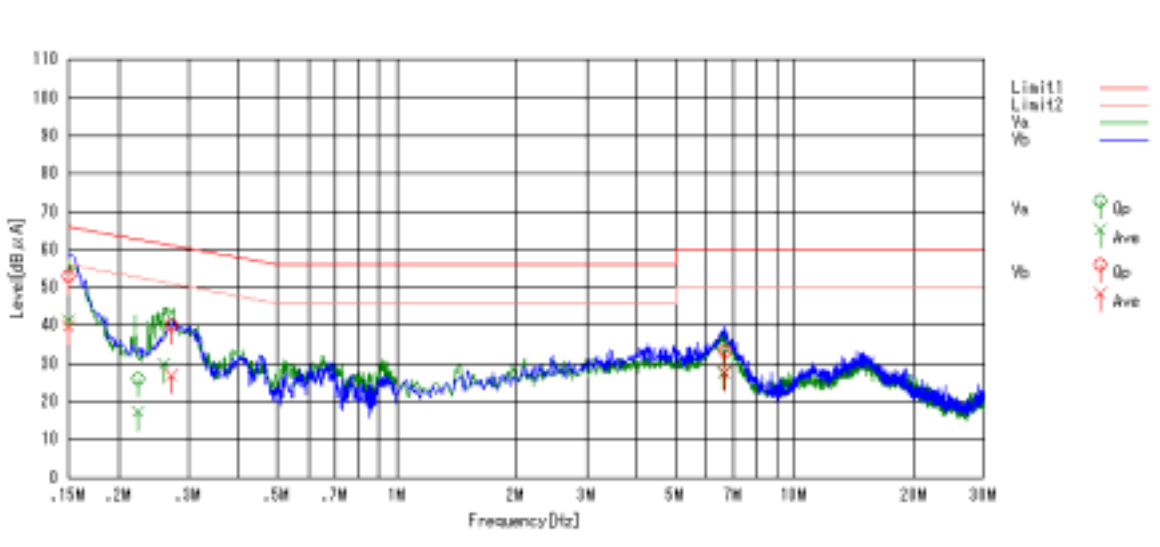

Test Equipment Used

Equipment name	RFT ID No.
EMI Receiver	TR06
LISN	LN06
RF cable	CL11

Final Result

The EUT met the requirements of the standard for this test

4 List of utilized test equipment/ calibration

RFT ID No.	Kind of Equipment and Precision	Manufacturer	Model No.	Serial Number	Calibration Date	Calibrated until
AC01	Anechoic Chamber (1st test room)	JSE	203397C	-	2008/7/4	2009/7/3
BA03	Biological Antenna	CHASE	CBL6111	1309	2008/5/7	2009/5/6
CL11	Antenna Cable	RFT	-	-	2008/6/11	2009/6/10
LN05	LISN	Kyoritsu	KNW-407	8-1773-2	2008/5/21	2009/5/20
LN06	LISN	Kyoritsu	KNW-407	8-1773-3	2008/5/12	2009/5/11
PR03	Pre. Amplifier	Anritsu	MH648A	M41984	2008/5/12	2009/5/11
PR04	Pre. Amplifier (1-26G)	RFT	LNP126	060208-01	2008/6/10	2009/6/9
TR04	Test Receiver (F/W : 3.82 SP1)	Rohde & Schwarz	ESCI	100447	2008/9/16	2009/9/15
TR06	Test Receiver (F/W : 3.93 SP2)	Rohde & Schwarz	ESU26	100002	2008/9/2	2009/9/1

The measuring equipment, which was utilized in performing the tests documented herein, has been calibrated in accordance with the manufacturer's recommendations for utilizing calibration equipment, which is traceable to recognized national standards.