

TEST REPORT

For

Mobile phone incorporated with Bluetooth

In conformity with

FCC CFR 47 Part15 (October 1, 2007) / RSS-210 Issue 7, RSS-Gen Issue 2

Model: F-01A

FCC ID/ IC Certification No.: VQK-F-01A / 337E-F01A

Test Item: Mobile phone incorporated with Bluetooth

Report No: RY0808Z12R1

Issue Date: 12 August 2008

Prepared for

Fujitsu Limited
1-1, Kamikodanaka 4-chome, Nakahara-ku, Kawasaki 211-8588,
Japan

Prepared by

RF Technologies Ltd.
472, Nippa-cho, Kohoku-ku, Yokohama, 223-0057, Japan
Telephone: +81+(0)45- 534-0645
FAX: +81+(0)45- 534-0646

This report shall not be reproduced, except in full, without the written permission of RF Technologies Ltd. The test results relate only to the item(s) tested. RF Technologies Ltd. is managed to ISO17025 and has the necessary knowledge and test facilities for testing according to the referenced standards.

Table of contents

1	General information.....	3
1.1	Product description	3
1.2	Test(s) performed/ Summary of test result	3
1.3	Test facility	4
1.4	Measurement uncertainty.....	4
1.5	Summary of test results.....	5
1.5.1	Table of test summary.....	5
1.6	Setup of equipment under test (EUT).....	5
1.6.1	Test configuration of EUT	5
1.6.2	Operating condition:	6
1.6.3	Setup diagram of tested system:.....	6
1.7	Equipment modifications	6
1.8	Deviation from the standard	6
2	Test procedure and test data	7
2.1	Occupied Bandwidth (20 dB / 99%).....	7
2.2	Hopping Carrier Frequency Separation	10
2.3	Number of Hopping Channel.....	12
2.4	Average Time of Occupancy	14
2.5	Peak Output Power	18
2.6	Conducted Spurious Emissions (Antenna Port).....	20
2.7	Transmitter Radiated spurious emissions	24
2.7.1	Below 30 MHz.....	26
2.7.2	Between 30 – 1000 MHz	27
2.7.3	Above 1000 MHz.....	29
2.8	Transmitter AC power line conducted emissions	33
2.9	Receiver Radiated spurious emissions	36
2.9.1	Between 30 – 1000 MHz	36
2.9.2	Above 1000 MHz.....	38
2.10	Receiver AC power line conducted emissions.....	39
3	Test setup photographs	42
3.1	Definition of the EUT axis.....	42
3.2	Antenna Port Measurements	43
3.3	Radiated spurious emissions.....	44
3.4	AC power line conducted emissions.....	47
4	List of utilized test equipment/ calibration	48

1 General information

1.1 Product description

Test item : Mobile phone incorporated with Bluetooth
Manufacturer : Fujitsu Limited
Address : 1-1, Kamikodanaka 4-chome, Nakahara-ku, Kawasaki 211-8588, Japan
Model : F-01A
FCC ID : VQK-F-01A
IC Certification No : 337E-F01A
Serial numbers : 359935010016362
Fundamental Operated Frequency : Tx/Rx Freq. (2402 - 2480 MHz)
Oscillator frequencies : 26 MHz
Type of Modulation : FHSS (GFSK, $\pi/4$ DQPSK, 8DPSK)
RF Output Power : -0.82dBm (measured at the antenna terminal)
Antenna Gain : -1.05 dBi ($\lambda/4$ Monopole antenna)
Receipt date of EUT : 28 July 2008
Nominal power source voltages : DC 3.7V (Battery)

1.2 Test(s) performed/ Summary of test result

Test specification(s) : FCC CFR 47. Part 15 (October 1, 2007) / RSS-210 Issue 7, RSS-Gen Issue 2
Test method(s) : ANSI C63.4: 2003
Test(s) started : 28 July 2008
Test(s) completed : 12 August 2008
Purpose of test(s) : Grant for Certification of FCC / IC
Summary of test result : Complied

Note: The above judgment is only based on the measurement data and it does not include the measurement uncertainty. Accordingly, the statement below is applied to the test result.

The EUT complies with the limit required in the standard in case that the margin is not less than the measurement uncertainty in the Laboratory.

Compliance of the EUT is more probable than non-compliance is case that the margin is less than the measurement uncertainty in the Laboratory.

Test engineer : K. Ohnishi
K. Ohnishi

Reviewer : T. Ikegami
T. Ikegami

1.3 Test facility

The Federal Communications Commission has reviewed the technical characteristics of the test facilities at RF Technologies Ltd., located in 472, Nippa-cho, Kohoku-ku, Yokohama, 223-0057, Japan, and has found these test facilities to be in compliance with the requirements of 47 CFR Part 15, section 2.948, per October 1, 2007. The description of the test facilities has been filed under registration number 879401 at the Office of the Federal Communications Commission. The facility has been added to the list of laboratories performing these test services for the public on a fee basis.

The list of all public test facilities is available on the Internet at <http://www.fcc.gov>.

Registered by Voluntary Control Council for Interference by Information Technology Equipment (VCCI)

Each registered facility number is as follows;

Test site (Semi-Anechoic chamber 3m) R-2393

Test site (Shielded room) C-2617

Registered by Industry Canada (IC): The registered facility number is as follows;

Test site No. 1 (Semi-Anechoic chamber 3m): 6974A

Accredited by **National Voluntary Laboratory Accreditation Program (NVLAP)** for the emission tests stated in the scope of the certificate under Certificate Number 200780-0

This report must not be used by the client to claim product certification, approval, or endorsement by NVLAP, NIST, or any agency of the Federal Government.



NVLAP LAB CODE 200780-0

1.4 Measurement uncertainty

The treatment of uncertainty is based on the general matters on the definition of uncertainty in “Guide to the expression of uncertainty in measurement (GUM)” published by ISO. The Lab’s uncertainty is determined by referring UKAS Publication LAB34: 2002 “The Expression of Uncertainty in EMC Testing” and CISPR16-4-2: 2003 “Uncertainty in EMC Measurements”.

The uncertainty of the measurement result in the level of confidence of approximately 95% (k=2) is as follows;

Conducted emission: ± 1.9 dB (10 kHz – 30 MHz)

Radiated emission (9 kHz - 30MHz): ± 2.8 dB

Radiated emission (30MHz - 1000MHz): ± 5.7 dB

Radiated emission (above 1000MHz): ± 5.8 dB

1.5 Summary of test results

1.5.1 Table of test summary

Requirement of;	Section in FCC15	Section in RSS210/ RSS-Gen	Result	Section in this report
1.5.1 Occupied Bandwidth (20 dB/99%)	15.247(a)(1)	A8.1(1)	-	2.1
1.5.2 Hopping Carrier Frequency Separation	15.247(a)(1)	A8.1(2)	Complied	2.2
1.5.3 Number of Hopping Channel	15.247(a)(1)(iii)	A8.1(4)	Complied	2.3
1.5.4 Average Time of Occupancy	15.247(a)(1)(iii)	A8.1(4)	Complied	2.4
1.5.5 Peak Output Power	15.247(a)(1)/(b)(1)	A8.4(2)	Complied	2.5
1.5.6 Conducted Spurious Emissions	15.247(d)	A8.5	Complied	2.6
1.5.7 Transmitter Radiated Spurious Emissions	15.205(b)/15.209	A8.5	Complied	2.7
1.5.8 Transmitter AC Power Line Conducted Emissions	15.207	RSS-Gen 7.2.2	Complied	2.8
1.5.9 Receiver Radiated Spurious Emissions	15.109	RSS-Gen 6	Complied	2.9
1.5.10 Receiver AC Power Line Conducted Emissions	15.107	RSS-Gen 7.2.2	Complied	2.10

1.6 Setup of equipment under test (EUT)

1.6.1 Test configuration of EUT

Equipment(s) under test:

	Item	Manufacturer	Model No.	Serial No.
A	Mobile phone incorporated with Bluetooth	Fujitsu Limited	F-01A	359935010016362
B	Li-ion Battery Pack	Fujitsu Limited	F10	AAF29105

Support Equipment(s):

	Item	Manufacturer	Model No.	Serial No.
C	AC Adapter	NEC Corporation	MAS-BH0008-A 002	QKA

Connected cable(s):

No.	Item	Identification (Manu.e.t.c)	Shielded YES / NO	Ferrite Core YES / NO	Connector Type Shielded YES / NO	Length (m)
1	DC power cable	NEC Corporation	No	No	No	0.6
2	AC power cable	NEC Corporation	No	No	No	1.3

1.6.2 Operating condition:

Operating mode:

The EUT was tested under the following test mode prepared by the applicant:

- (1-1) GMSK modulation, Continuous transmission with DH1/3/5 PACKET at hopping off (2402MHz)
- (1-2) GMSK modulation, Continuous transmission with DH1/3/5 PACKET at hopping off (2441MHz)
- (1-3) GMSK modulation, Continuous transmission with DH1/3/5 PACKET at hopping off (2480MHz)
- (1-4) $\pi/4$ DQPSK modulation, Continuous transmission with DH1/3/5 PACKET at hopping off (2402MHz)
- (1-5) $\pi/4$ DQPSK modulation, Continuous transmission with DH1/3/5 PACKET at hopping off (2441MHz)
- (1-6) $\pi/4$ DQPSK modulation, Continuous transmission with DH1/3/5 PACKET at hopping off (2480MHz)
- (1-7) 8DQPSK modulation, Continuous transmission with DH1/3/5 PACKET at hopping off (2402MHz)
- (1-8) 8DQPSK modulation, Continuous transmission with DH1/3/5 PACKET at hopping off (2441MHz)
- (1-9) 8DQPSK modulation, Continuous transmission with DH1/3/5 PACKET at hopping off (2480MHz)
- (1-10) Continuous transmission with DH1/3/5 PACKET at hopping on
- (2-1) Continuous receiving (2402MHz)
- (2-2) Continuous receiving (2441MHz)
- (2-3) Continuous receiving (2480MHz)

1.6.3 Setup diagram of tested system:

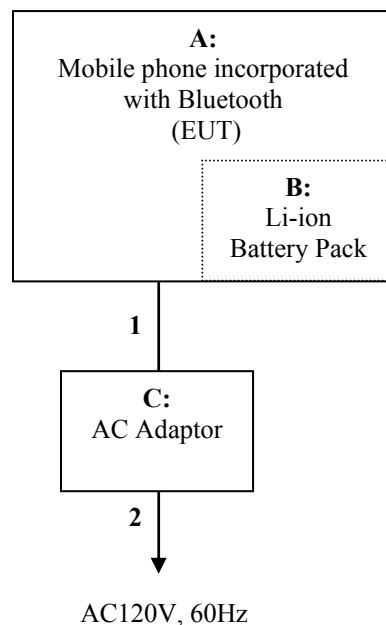

1.7 Equipment modifications

No modifications have been made to the equipment in order to achieve compliance with the applicable standards described in clause 1.2.

1.8 Deviation from the standard

No deviations from the standards described in clause 1.2.

2 Test procedure and test data

2.1 Occupied Bandwidth (20 dB / 99%)

Test setup

Test setup is the following drawing. The antenna port of EUT was connected to the spectrum analyzer.

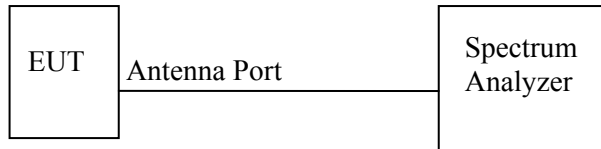

Test procedure

Measurement procedures were implemented according to the method of ANSI C63.4: 2003 clauses 13.1.7. The EUT antenna port connected to the spectrum analyzer. The RBW is set to 1% to 3% of the measured 20dB bandwidth. The VBW is set to 3 times of the RBW. The sweep time is coupled appropriate.

Limitation

There are no limitations. The measurement value is used to calculation of the limitation of the channel separation and the emission designator.

Test equipment used (refer to List of utilized test equipment)

TR06	CL23				
------	------	--	--	--	--

Test results

Operating Mode	Transmission Channel	Transmission Frequency	Bandwidth [MHz]	
			20dB	99%
GFSK (1Mbps)	Low (0ch)	2402	1.298	1.103
	Middle (39ch)	2441	1.306	1.114
	High (78ch)	2480	1.306	1.114
$\pi/4$ DQPSK (2Mbps)	Low (0ch)	2402	1.627	1.418
	Middle (39ch)	2441	1.643	1.426
	High (78ch)	2480	1.627	1.410
8DPSK (3Mbps)	Low (0ch)	2402	1.659	1.410
	Middle (39ch)	2441	1.643	1.426
	High (78ch)	2480	1.635	1.410

Test Data

Tested Date: July 30, 2008

Temperature: 26 °C
 Humidity: 60 %
 Atmos. Press: 1008 hPa

20dB Bandwidth

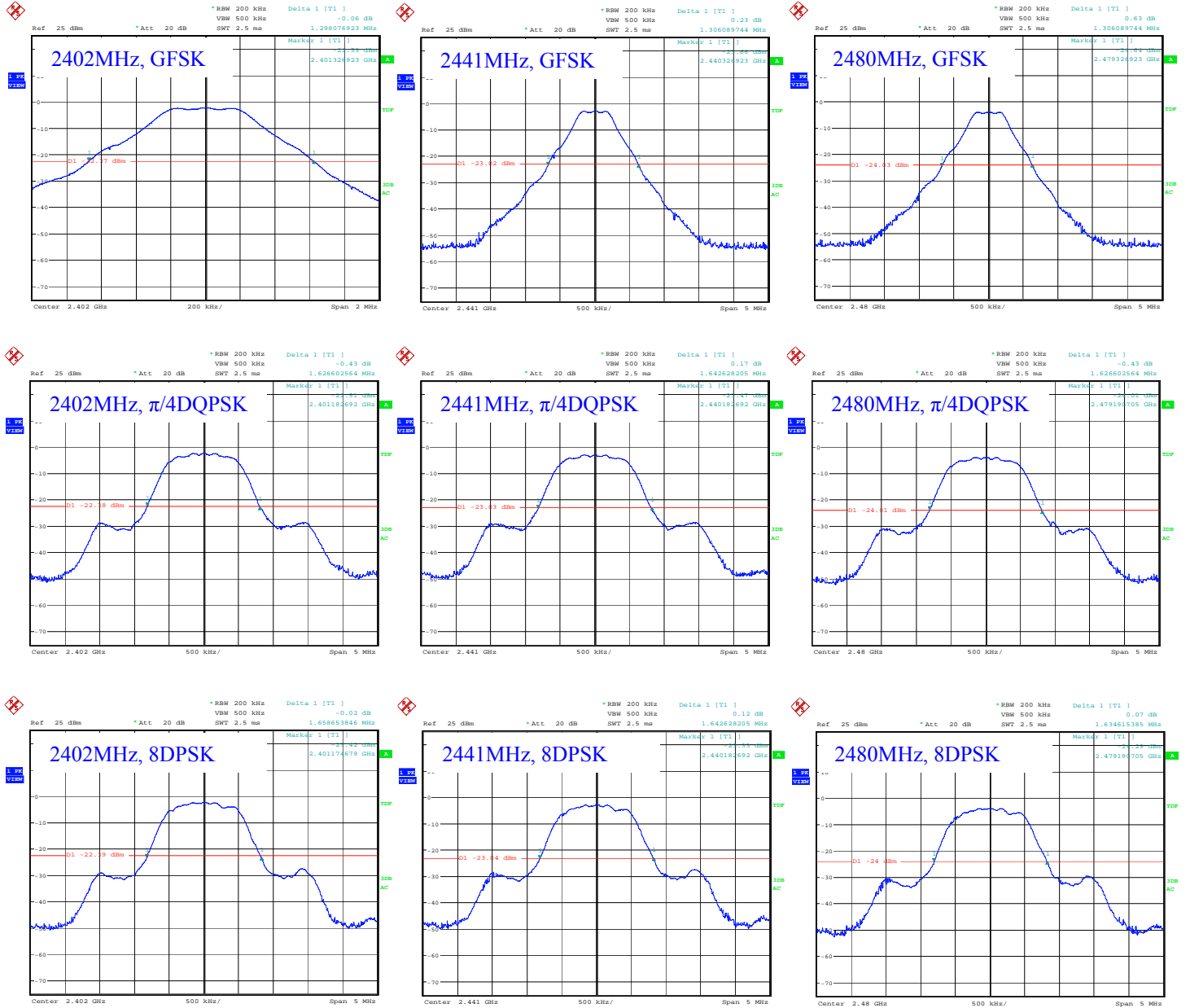

Date: 30.JUL.2008 17:09:06

Date: 30.JUL.2008 17:18:44

Date: 30.JUL.2008 17:26:36

99% Occupied Bandwidth

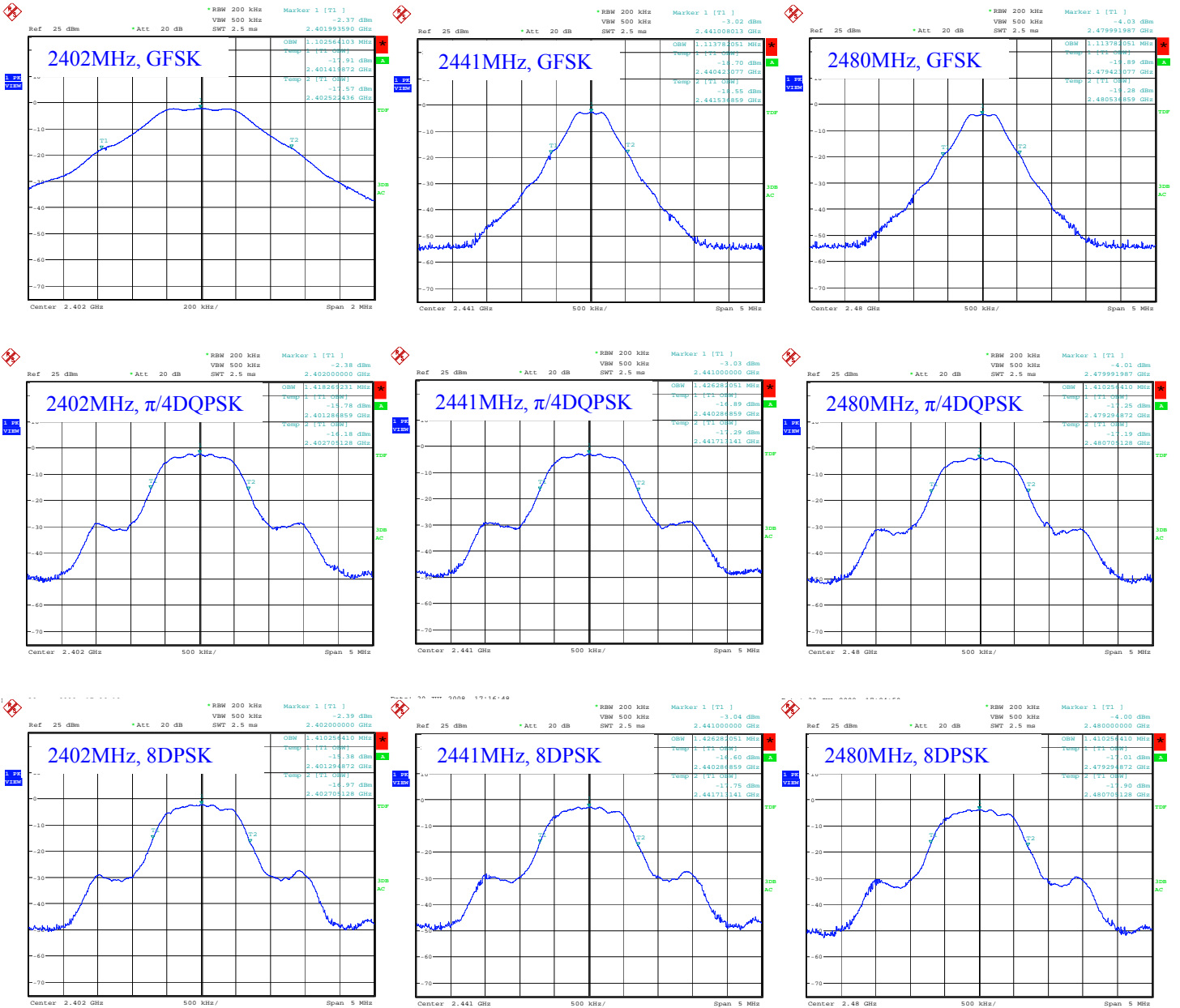

Date: 30.JUL.2008 17:09:54

Date: 30.JUL.2008 17:19:16

Date: 30.JUL.2008 17:27:05

2.2 Hopping Carrier Frequency Separation

Test setup

Test setup is the following drawing. The antenna port of EUT was connected to the spectrum analyzer.

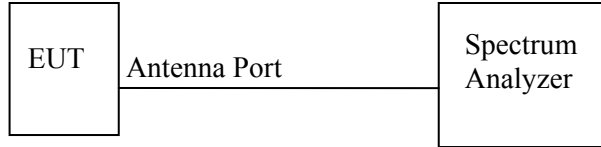

Test procedure

The EUT antenna port connected to the spectrum analyzer. The RBW is set to more than 1% of its span. The VBW is set to more than RBW. The sweep time is coupled appropriate.

Limitation

15.247(a)(1) frequency hopping systems operating in the 2400-2483.5 MHz band may have hopping channel carrier frequencies that are separated by 25 kHz or two-thirds of the 20 dB bandwidth of the hopping channel, whichever is greater, provided the systems operate with an output power no greater than 125 mW. Therefore limitation value is greater than 865.3 kHz.

Test equipment used (refer to List of utilized test equipment)

TR06	CL23				
------	------	--	--	--	--

Test results – comply with the limitation

Operating Mode	Measured Channel	Measured Frequency (MHz)	Frequency Separation (MHz)
GFSK	Middle (39ch)	2441	1.0
$\pi/4$ DQPSK	Middle (39ch)	2441	1.0
8DPSK	Middle (39ch)	2441	1.0

Test Data

Tested Date: July 30, 2008

Temperature: 26 °C
 Humidity: 60 %
 Atmos. Press: 1008 hPa

Operating mode: GFSK

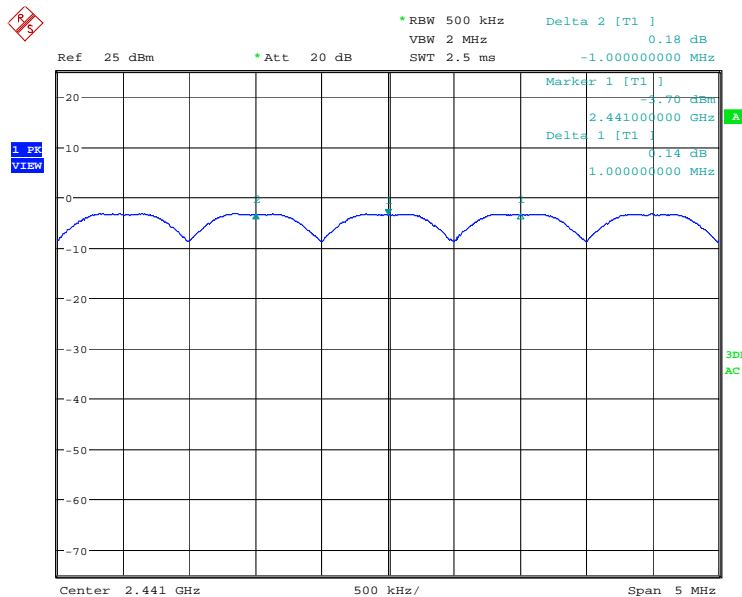

Operating mode: $\pi/4$ DQPSK

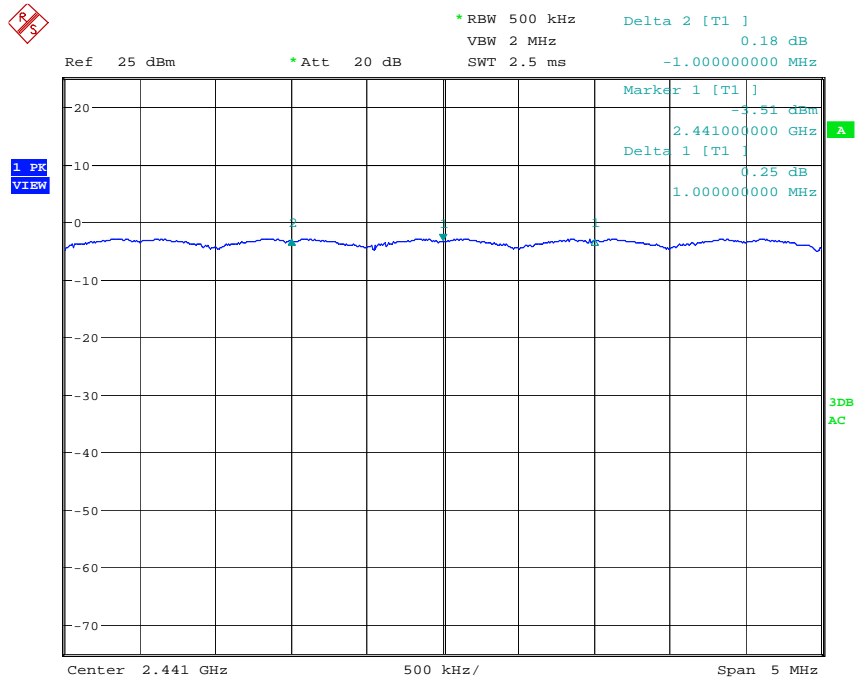

Operating mode: 8DPSK

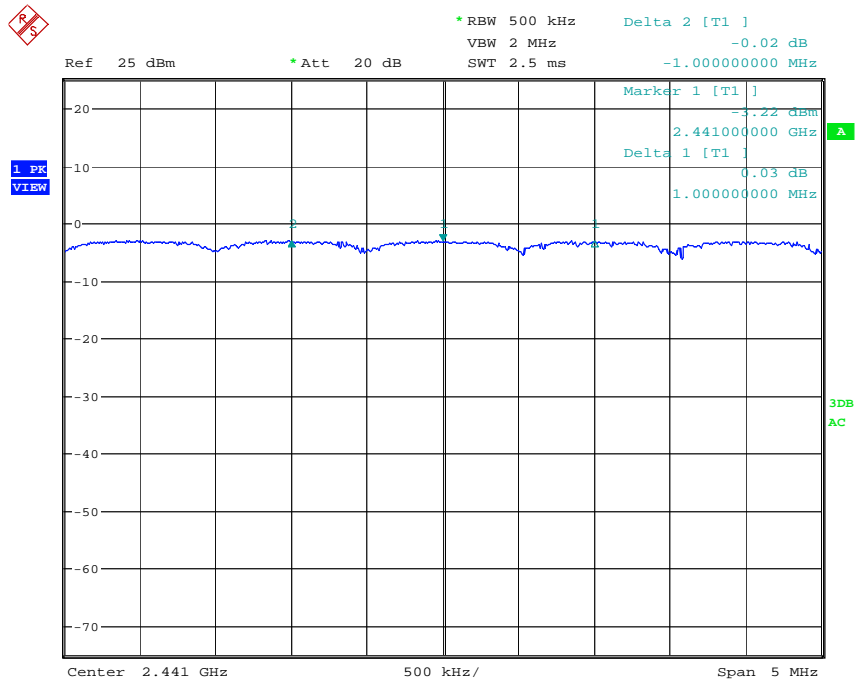

2.3 Number of Hopping Channel

Test setup

Test setup is the following drawing. The antenna port of EUT was connected to the spectrum analyzer.

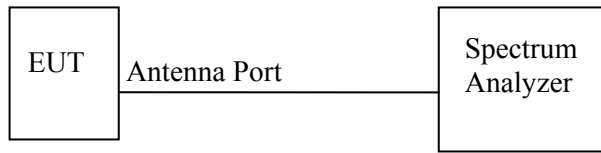

Test procedure

The EUT antenna port connected to the spectrum analyzer. The RBW is set to more than 1% of its span. The VBW is set to more than RBW. The sweep time is coupled appropriate. The span is set to cover the authorized band. The analyzer is set to MAX HOLD. The EUT is hopping operation.

Limitation

15.247(a) (1) (iii) (iii) Frequency hopping systems in the 2400-2483.5 MHz band shall use at least 15 channels.

Test equipment used (refer to List of utilized test equipment)

TR06	CL23				
------	------	--	--	--	--

Test results – Comply with the limitation

Hopping channel: 79 channels

Test Data

Tested Date: July 30, 2008

Temperature: 26 °C
 Humidity: 60 %
 Atmos. Press: 1008 hPa

Operating mode: GFSK

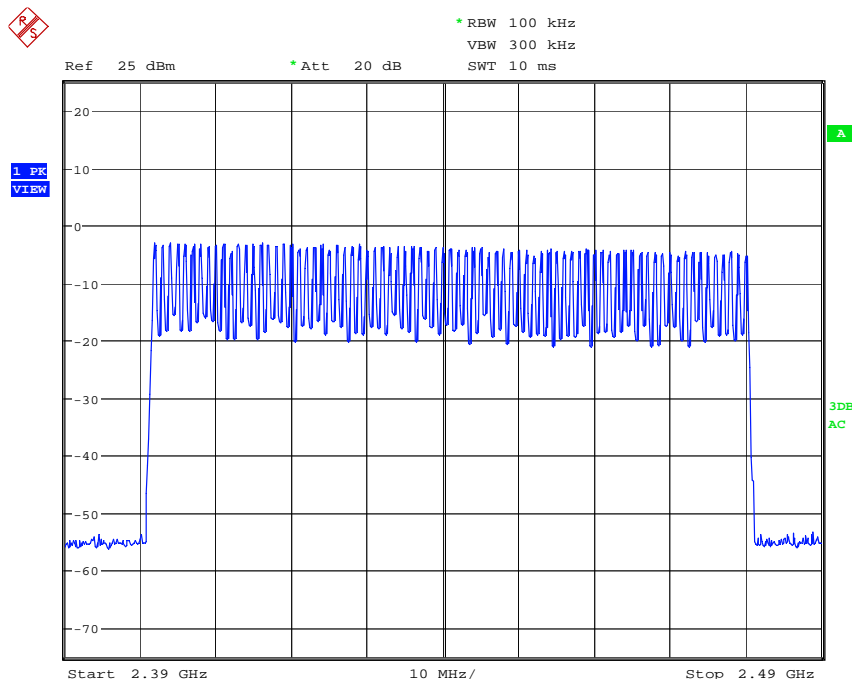

Operating mode: $\pi/4$ DQPSK

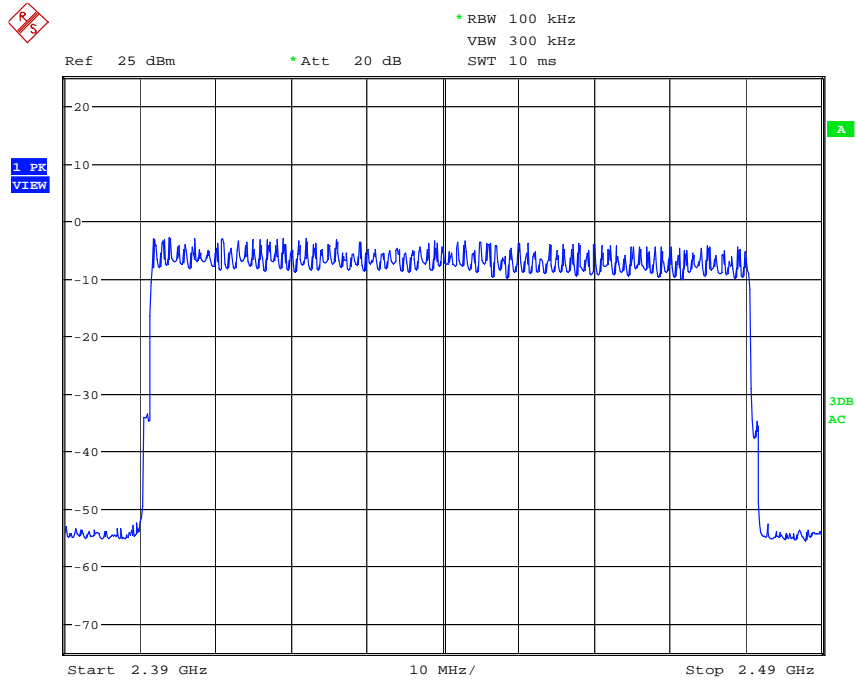

Operating mode: 8DPSK

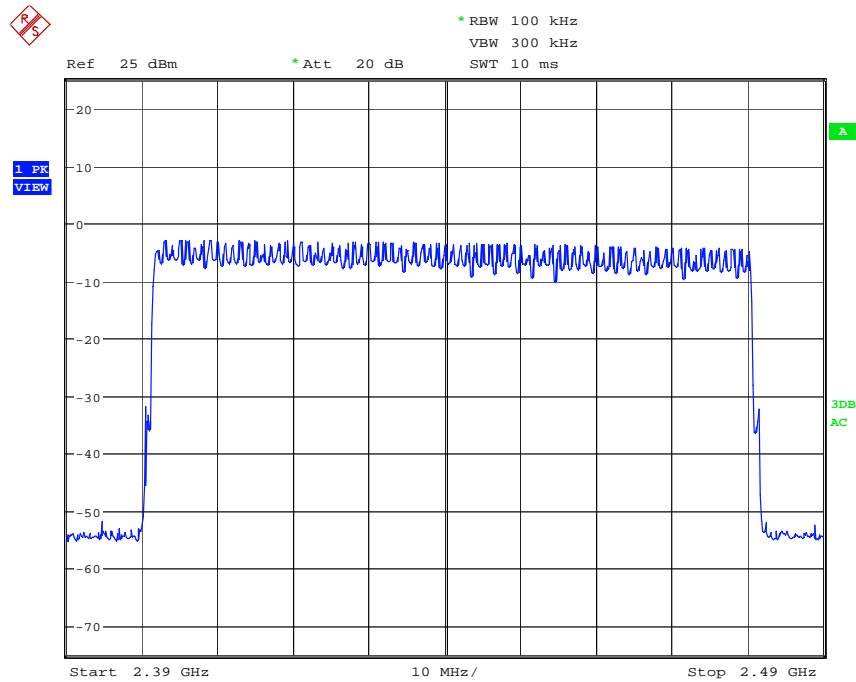

2.4 Average Time of Occupancy

Test setup

Test setup is the following drawing. The antenna port of EUT was connected to the spectrum analyzer.

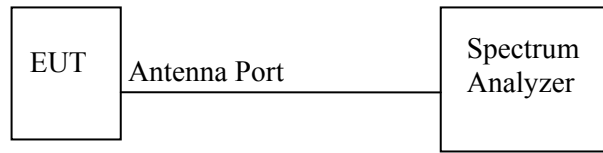

Test procedure

The EUT antenna port connected to the spectrum analyzer. The RBW is set to 1 MHz. The VBW is set to more than RBW. The sweep time is coupled appropriate. The span is set to 0 MHz and single sweep with video triggered. The EUT is hopping operation.

The average time of occupancy within the 31.6 seconds (79 channels * 0.4) is calculated as follows in accordance with Bluetooth formula;

In case of DH1: (average time of occupancy) = (pulse width) * (1600 / 2) / 79 * 31.6

In case of DH3: (average time of occupancy) = (pulse width) * (1600 / 4) / 79 * 31.6

In case of DH5: (average time of occupancy) = (pulse width) * (1600 / 6) / 79 * 31.6

Limitation

15.247(a)(1)(iii) The average time of occupancy on any channel shall not be greater than 0.4 seconds within a period of 0.4 seconds multiplied by the number of hopping channels employed.

Test equipment used (refer to List of utilized test equipment)

TR06	CL23				
------	------	--	--	--	--

Test results – comply with the limitation.

Operating Mode	Frequency [MHz]	Transmission Packet Type	Pulse width (msec)	Time of occupancy (msec)
GFSK	2402	DH1	0.386	123.520
		DH3	1.644	263.040
		DH5	2.878	306.987
	2441	DH1	0.386	123.520
		DH3	1.636	261.760
		DH5	2.894	308.693
	2480	DH1	0.383	122.560
		DH3	1.649	263.840
		DH5	2.899	309.227
$\pi/4$ DQPSK	2402	DH1	0.391	125.120
		DH3	1.641	262.560
		DH5	2.907	310.080
	2441	DH1	0.388	124.160
		DH3	1.646	263.360
		DH5	2.896	308.907
	2480	DH1	0.389	124.480
		DH3	1.639	262.240
		DH5	2.889	308.160
8DPSK	2402	DH1	0.391	125.120
		DH3	1.641	262.560
		DH5	2.899	309.227
	2441	DH1	0.391	125.120
		DH3	1.641	262.560
		DH5	2.891	308.373
	2480	DH1	0.393	125.760
		DH3	1.643	262.880
		DH5	2.893	308.587

Test Data

Tested Date: July 30, 2008

Temperature: 26 °C
 Humidity: 60 %
 Atmos. Press: 1008 hPa

Operating mode: GFSK

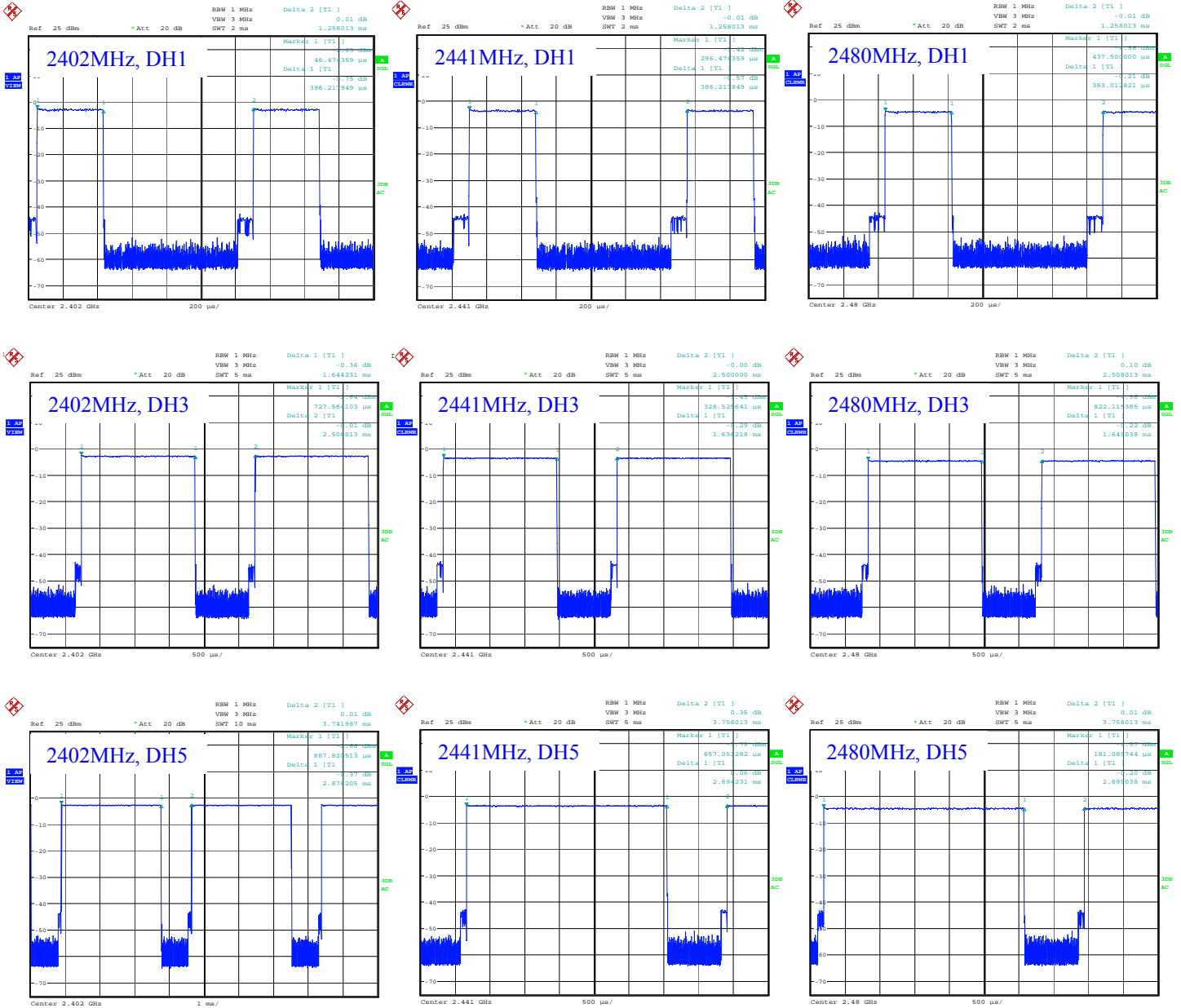

Operating mode: $\pi/4$ DQPSK

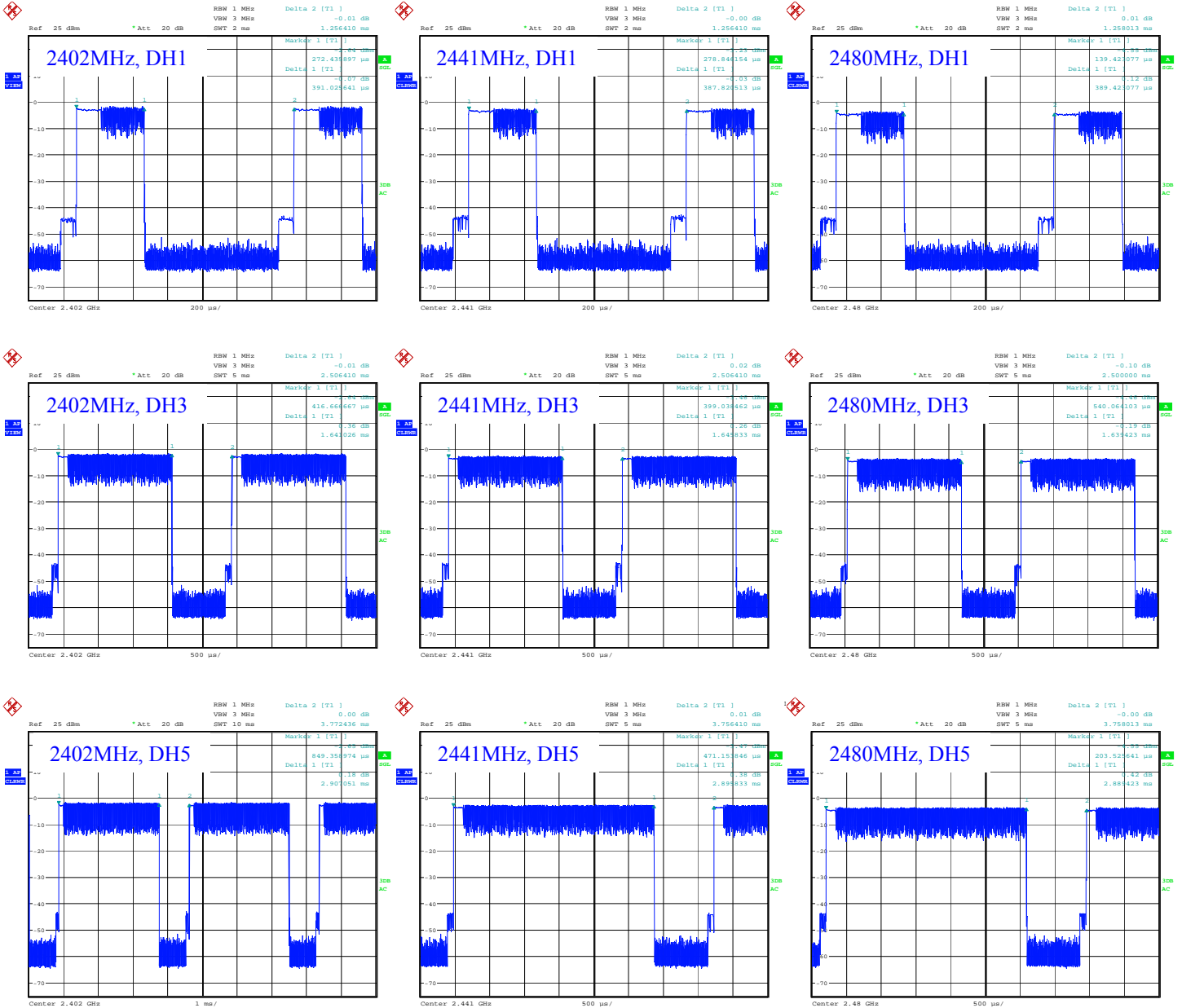

Operating mode: 8DPSK

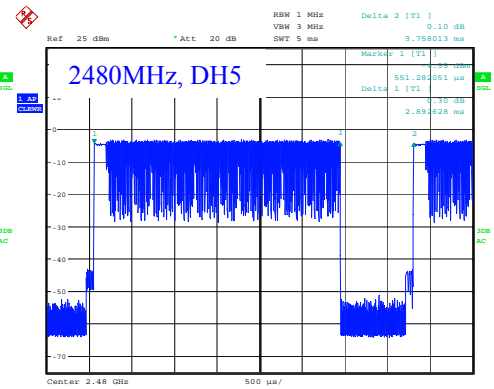
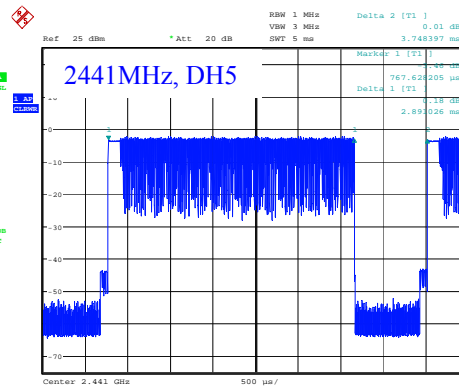
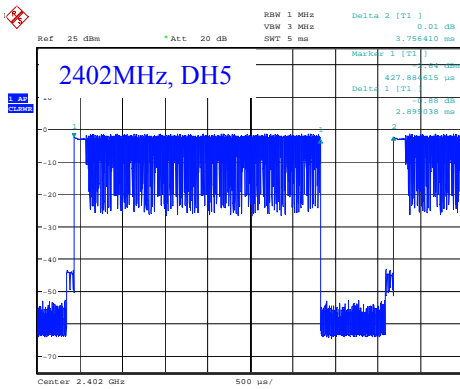
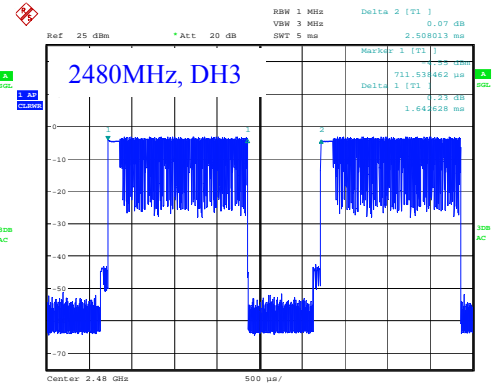
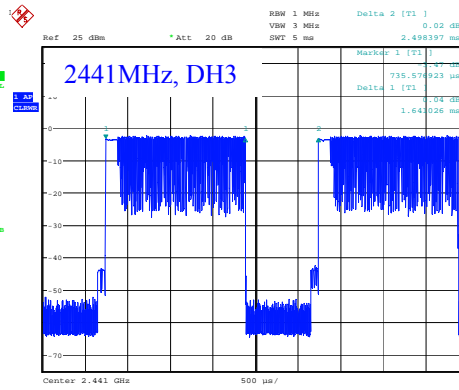
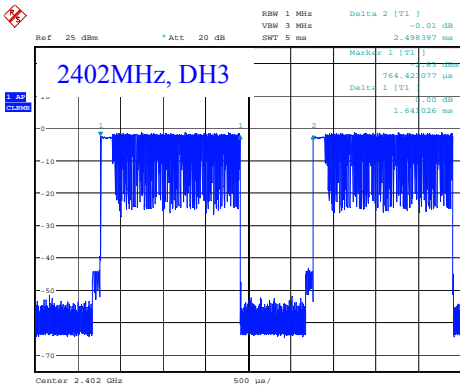
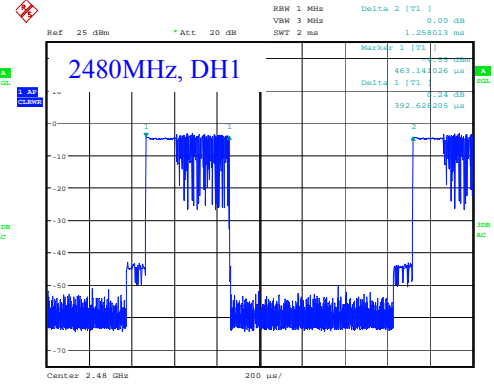
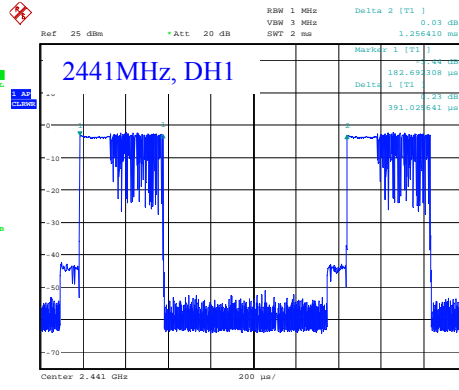
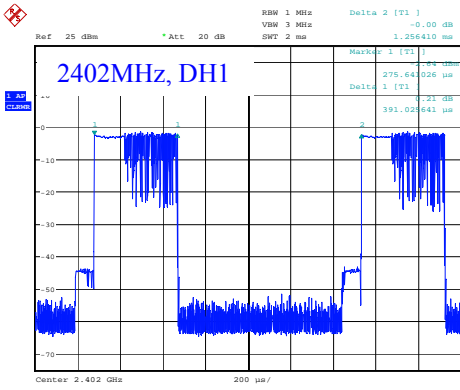

Date: 30.JUL.2008 14:48:51

Date: 30.JUL.2008 15:12:57

Date: 30.JUL.2008 15:29:20

2.5 Peak Output Power

Test setup

Test setup is the following drawing. The antenna port of EUT was connected to the spectrum analyzer.

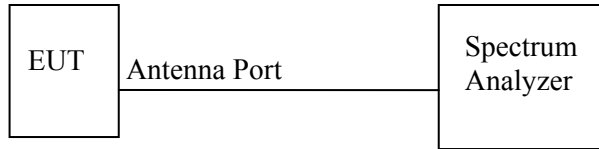

Test procedure

The EUT antenna port connected to the spectrum analyzer. The RBW is set to the greater than 20dB bandwidth. The VBW is set to three times of RBW. The sweep time is coupled appropriate. The span is set to cover the carrier output spectrum. The analyzer is set to MAX HOLD. The EUT is set measured transmission channel under hopping off mode.

The correction factor is set to the spectrum analyzer in order to correct of the connected cable loss.

Limitation

15.247(a) (1) Frequency hopping systems operating in the 2400-2483.5 MHz band may have hopping channel carrier frequencies that are separated by 25 kHz or two-thirds of the 20 dB bandwidth of the hopping channel, whichever is greater, provided the systems operate with an output power no greater than 125 mW(21dBm).

Test equipment used (refer to List of utilized test equipment)

TR06	CL23				
------	------	--	--	--	--

Test results – comply with the limitation.

Operating Mode	Transmission Channel (Frequency: MHz)	Cable loss (dB)	Output power (dBm)	Output power (mW)
GFSK	Low (2402)	0.98	-2.31	0.587
	Middle (2441)	0.78	-2.69	0.538
	High (2480)	0.93	-3.75	0.422
$\pi/4$ DQPSK	Low (2402)	0.98	-1.08	0.780
	Middle (2441)	0.78	-1.66	0.682
	High (2480)	0.93	-2.41	0.574
8DPSK	Low (2402)	0.98	-0.82	0.827
	Middle (2441)	0.78	-1.54	0.701
	High (2480)	0.93	-2.30	0.589

Test Data

Tested Date: July 30, 2008

Temperature: 26 °C
 Humidity: 60 %
 Atmos. Press: 1008 hPa

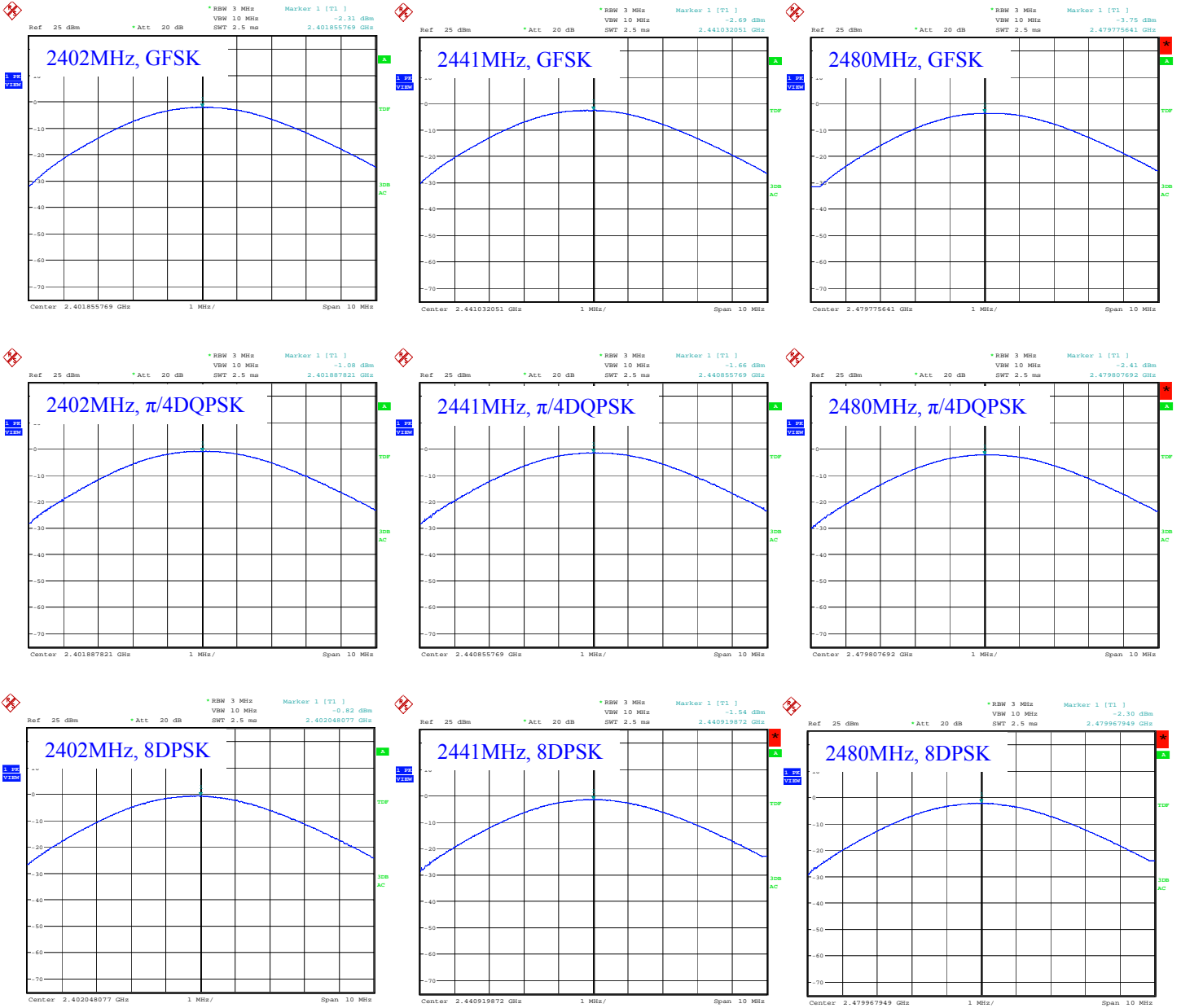

2.6 Conducted Spurious Emissions (Antenna Port)

Test setup

Test setup is the following drawing. The antenna port of EUT was connected to the spectrum analyzer.

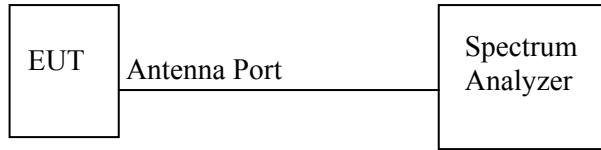

Test procedure

The EUT antenna port connected to the spectrum analyzer. The RBW is set to 100 kHz. The VBW is set to 300 kHz. The sweep time is set to the coupled. The spectrum is checked from 30 MHz to 26 GHz.

The EUT is set measured transmission channel under hopping off mode.

Limitation

15.247(d) In any 100 kHz bandwidth outside the frequency band in which the spread spectrum or digitally modulated intentional radiator is operating, the radio frequency power that is produced by the intentional radiator shall be at least 20 dB below that in the 100 kHz bandwidth within the band that contains the highest level of the desired power, based on either an RF conducted or a radiated measurement, provided the transmitter demonstrates compliance with the peak conducted power limits.

Test equipment used (refer to List of utilized test equipment)

TR06	CL23				
------	------	--	--	--	--

Test results – comply with the limitation.

There were no conducted spurious emissions with levels of more than 20 dB below the applicable limit.

Test Data

Tested Date: July 30, 2008

Temperature: 26 °C
 Humidity: 60 %
 Atmos. Press: 1008 hPa

Low (0ch) 2402MHz

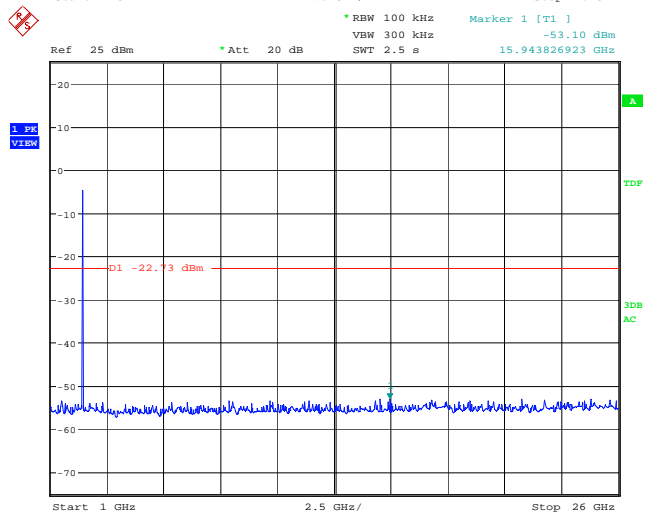
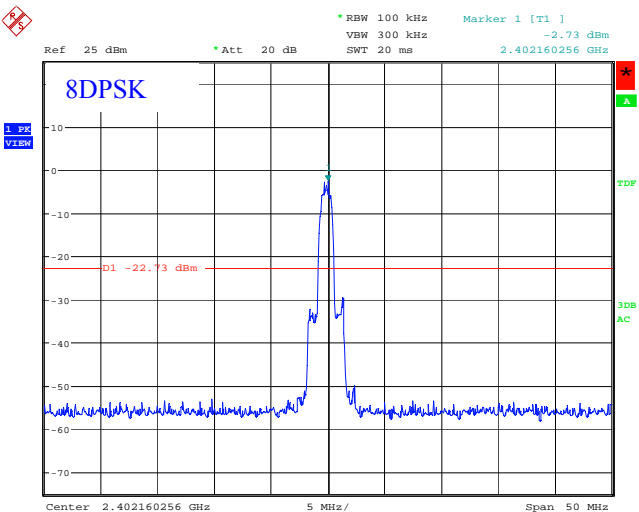
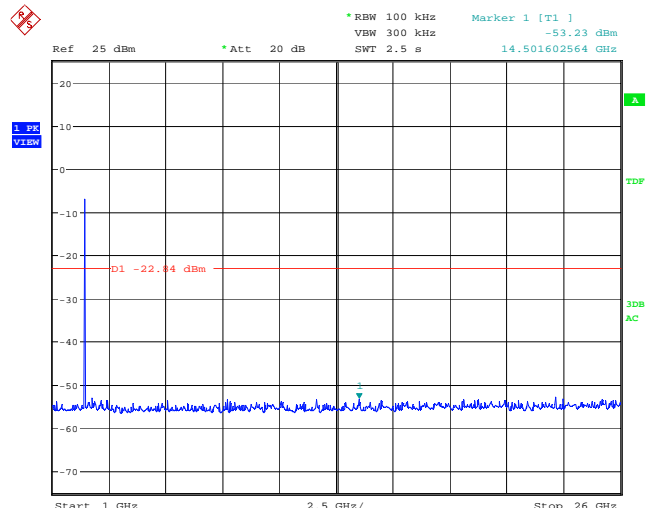
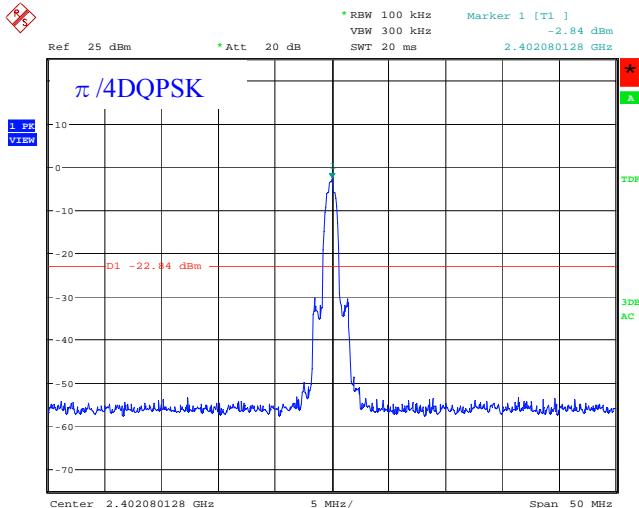
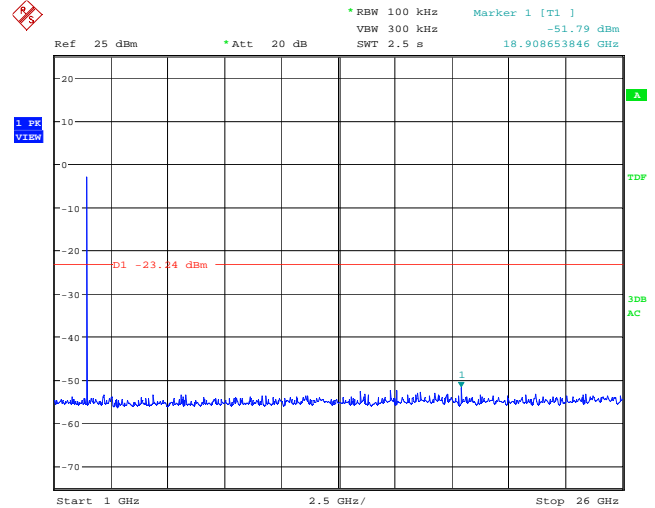
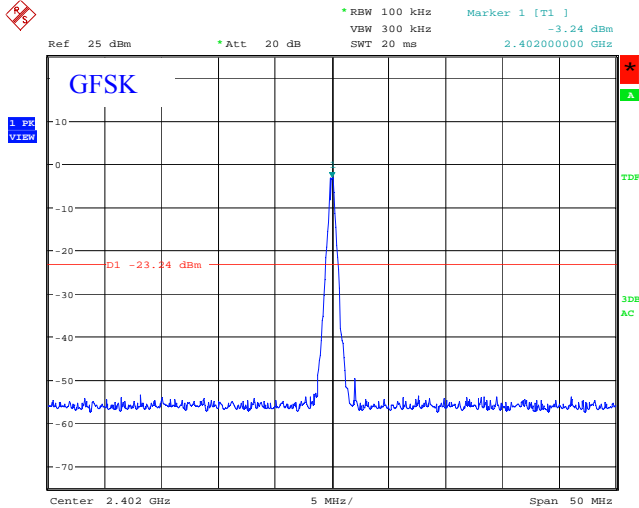

Middle (39ch) 2441MHz

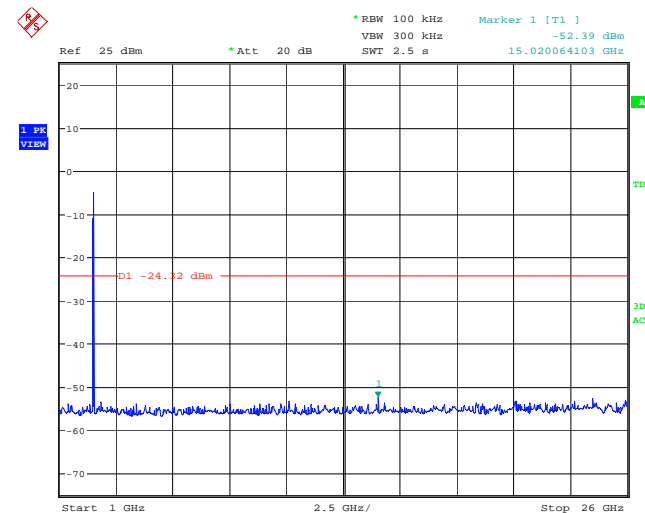
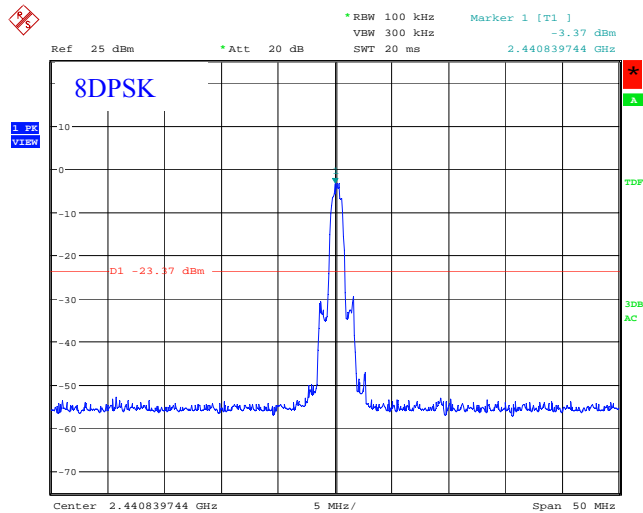
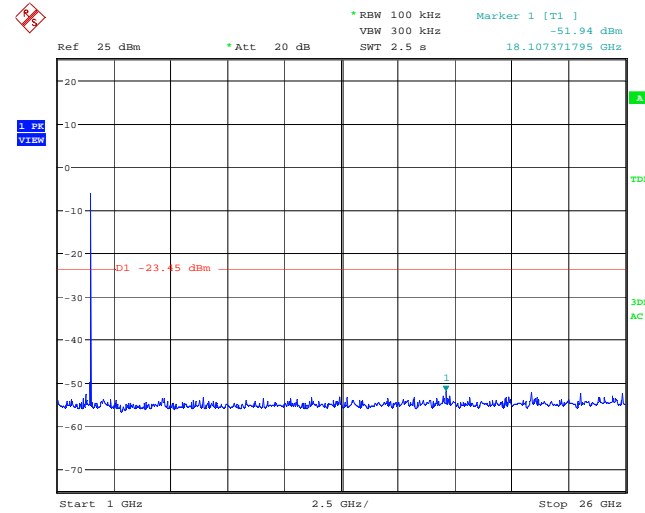
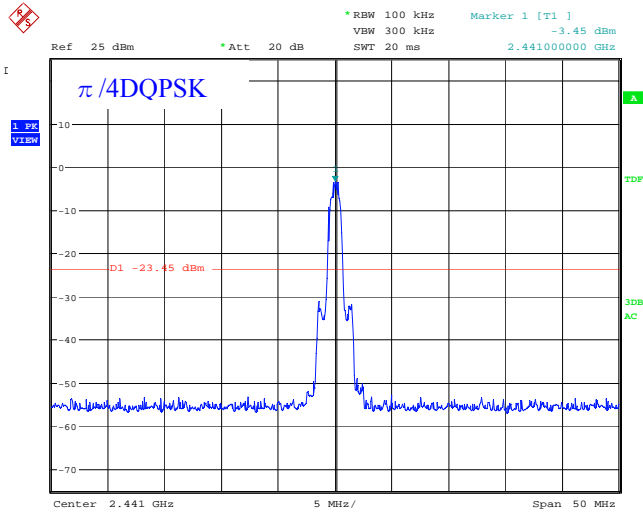
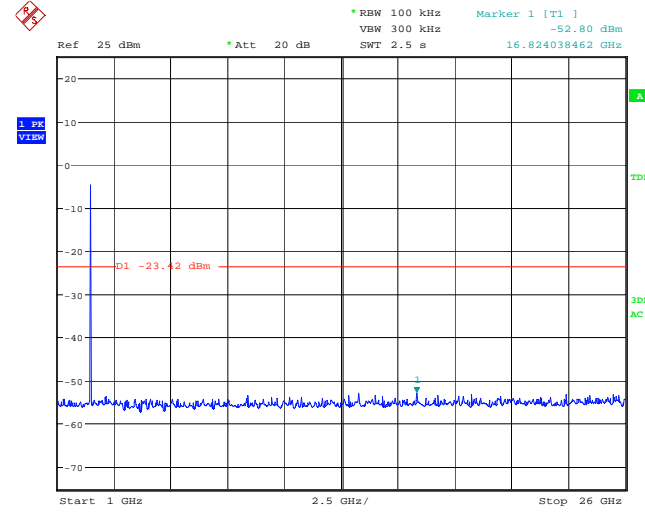
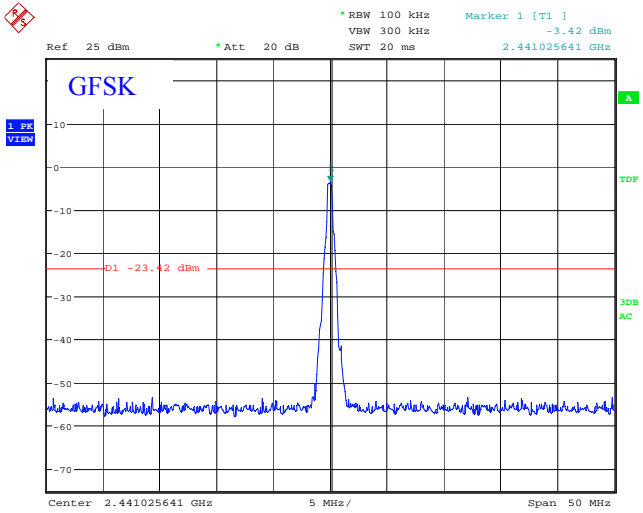

High (78ch) 2480MHz

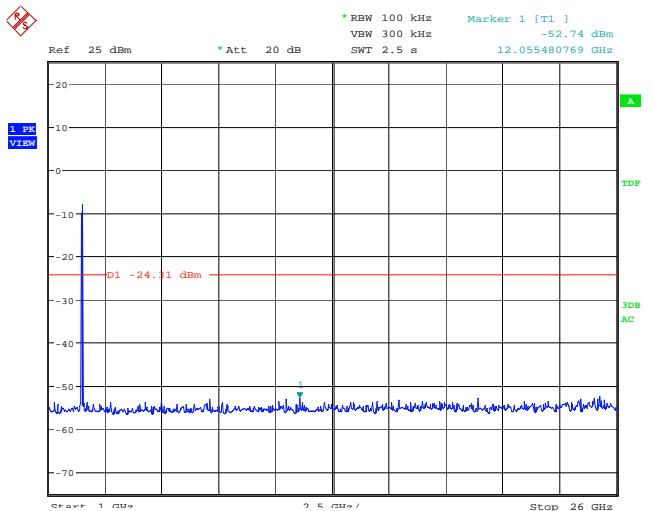
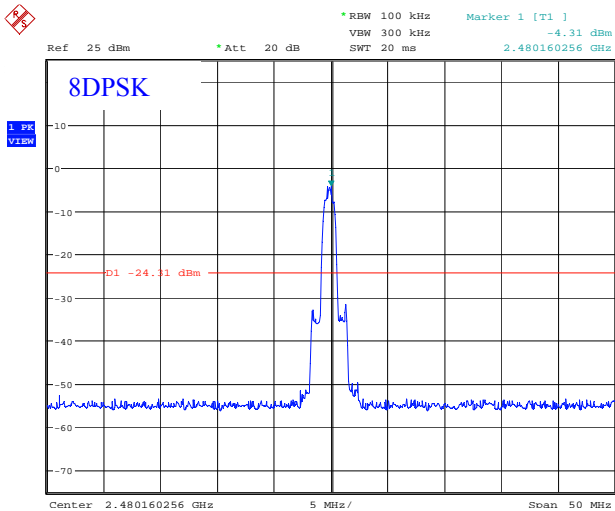
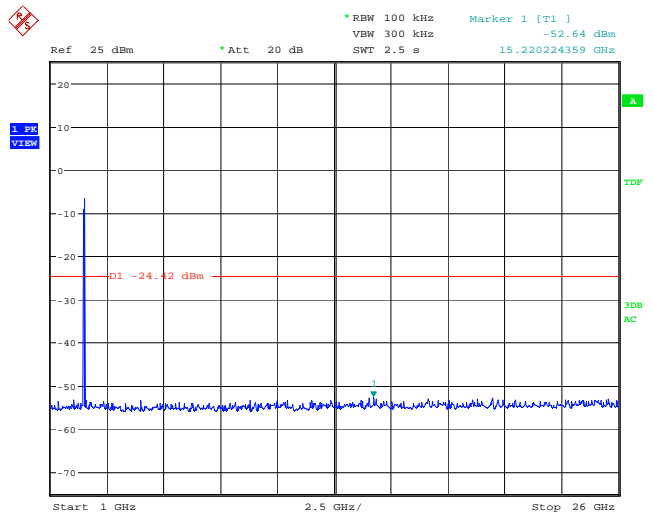
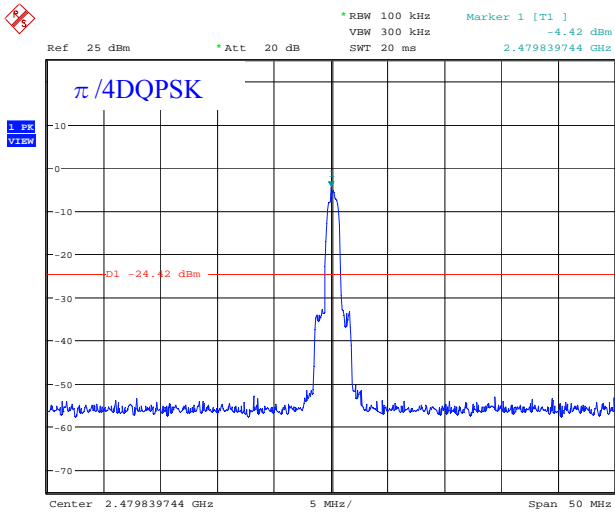
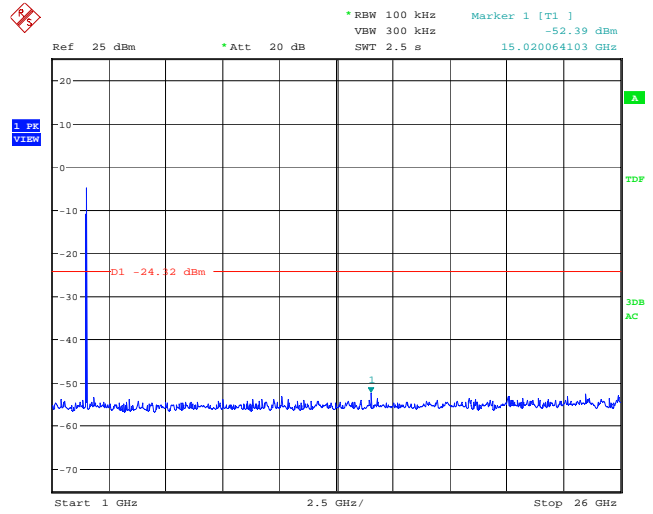
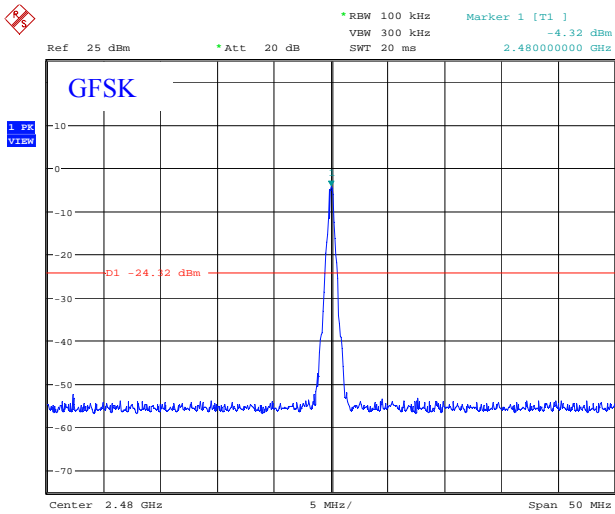

2.7 Transmitter Radiated spurious emissions

Test setup

Test setup was implemented according to the method of ANSI C63.4: 2003 clause 6 “General requirements for EUT equipment arrangements and operation”, clause 8.2 and Annex H.3 “Radiated emission measurements setup”.

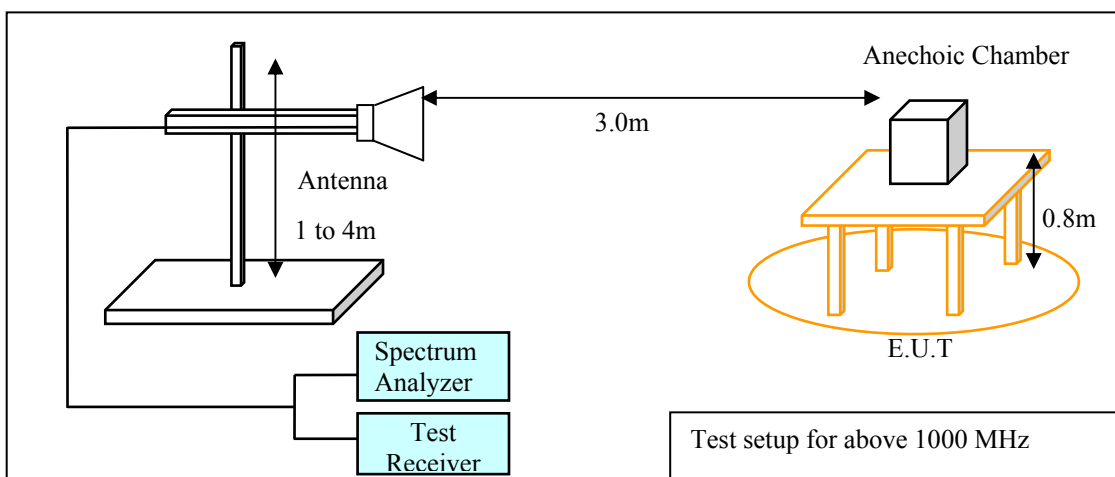
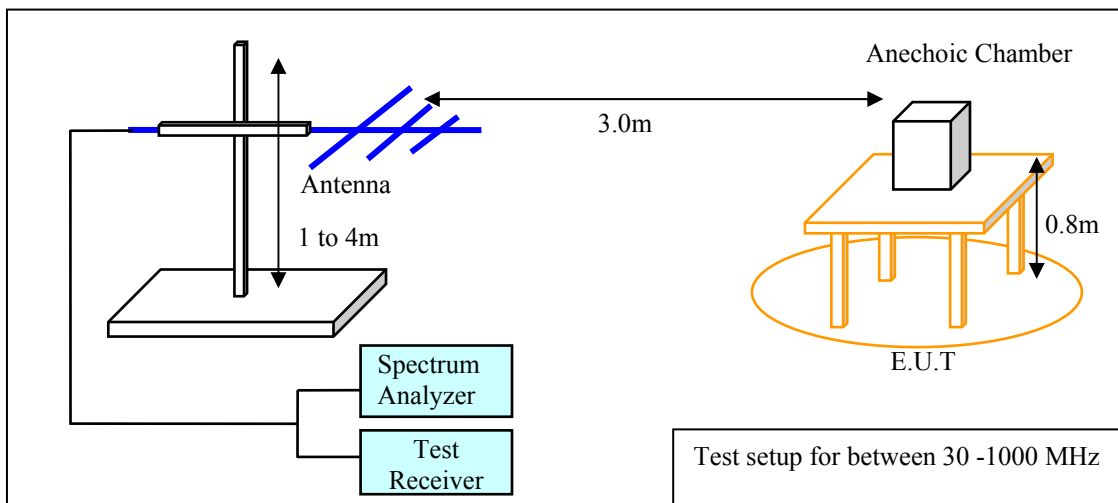
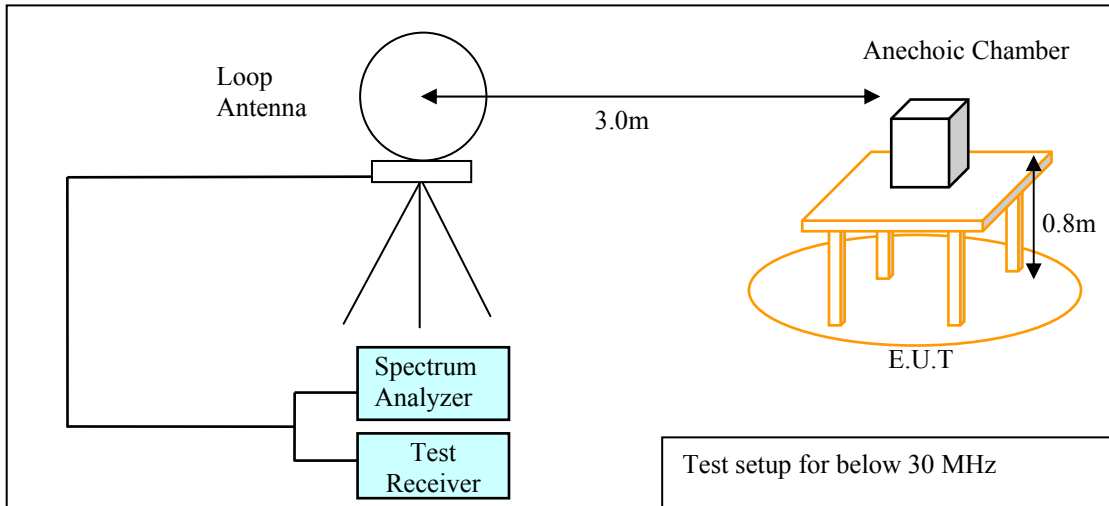

Test procedure

Measurement procedures were implemented according to the method of ANSI C63.4: 2003 clauses 8.2. The EUT is placed on a non-conducted table which is 0.8m height from a ground plane and the measurement antenna to EUT distance is 3 meters. The turn table is rotated for 360 degrees to determine the maximum emission level. In the frequency range of 9 kHz to 30 MHz, a calibrated loop antenna was positioned with its plane vertical at the distance 3m from the EUT with an extrapolation of corrected distance factor and rotated about its vertical axis for maximum response at each azimuth about the EUT. For certain applications, the loop antenna also needs to be positioned horizontally. The center of the loop shall be 1 m above the ground. In the frequency above 30 MHz, the antenna height scanned between 1m and 4m, and the antenna rotated to repeat the measurements for both the horizontal and vertical antenna polarizations. EUT is placed at three different orientations (X, Y and Z axis) in order to find the worst orientation. The spectrum analyzer and receiver is set to the followings;

- Below 30 MHz: RBW=10 kHz, VBW= 30 kHz
Final measurement is carried out with a receiver RBW of 9 kHz (QP)
- Between 30 - 1000 MHz: RBW=100 kHz, VBW= 300 kHz
Final measurement is carried out with a receiver RBW of 120 kHz (QP)
- Above 1000 MHz: Peak measurement- RBW=1 MHz, VBW= 1 MHz
Average measurement – RBW=1 MHz, VBW=10 Hz

Applicable rule and limitation

§15.205 restricted bands of operation

Except as shown in paragraph 15.205 (d) of this section, only spurious emissions are permitted in any of the frequency bands listed below:

MHz	MHz	MHz	GHz
0.090 - 0.110	16.42 - 16.423	399.9 - 410	4.5 - 5.15
0.490 - 0.510	16.69475 - 16.69525	608 - 614	5.35 - 5.46
2.1735 - 2.1905	16.80425 - 16.80475	960 - 1240	7.25 - 7.75
4.125 - 4.128	25.5 - 25.67	1300 - 1427	8.025 - 8.5
4.17725 - 4.17775	37.5 - 38.25	1435 - 1626.5	9.0 - 9.2
4.20725 - 4.20775	73 - 74.6	1645.5 - 1646.5	9.3 - 9.5
6.215 - 6.218	74.8 - 75.2	1660 - 1710	10.6 - 12.7
6.26775 - 6.26825	108 - 121.94	1718.8 - 1722.2	13.25 - 13.4
6.31175 - 6.31225	123 - 138	2200 - 2300	14.47 - 14.5
8.291 - 8.294	149.9 - 150.05	2310 - 2390	15.35 - 16.2
8.362 - 8.366	156.52475 - 156.52525	2483.5 - 2500	17.7 - 21.4
8.37625 - 8.38675	156.7 - 156.9	2690 - 2900	22.01 - 23.12
8.41425 - 8.41475	162.0125 - 167.17	3260 - 3267	23.6 - 24.0
12.29 - 12.293	167.72 - 173.2	3332 - 3339	31.2 - 31.8
12.51975 - 12.52025	240 - 285	3345.8 - 3358	36.43 - 36.5
12.57675 - 12.57725	322 - 335.4	3600 - 4400	(1)

15.205(b) except as provided in paragraphs (d) and (e), the field strength of emissions appearing within these frequency bands shall not exceed the limits shown in Section 15.209. At frequencies equal to or less than 1000 MHz, compliance with the limits in Section 15.209 shall be demonstrated using measurement instrumentation employing a CISPR quasi-peak detector. Above 1000 MHz, compliance with the emission limits in Section 15.209 shall be demonstrated based on the average value of the measured emissions. The provisions in Section 15.35 apply to these measurements.

15.209(a) Except as provided elsewhere in this Subpart, the emissions from an intentional radiator shall not exceed the field strength levels specified in the following table

Frequency (MHz)	Field Strength (uV/m)	Measurement Distance (m)
0.009 - 0.490	2400/F (kHz)	300
0.490 - 1.705	24000/F (kHz)	30
1.705 - 30.0	30	30
30 – 88	100	3
88 –216	150	3
216 – 960	200	3
Above 960	500	3

In the emission table above, the tighter limit applies at the band edges.

The level of any unwanted emissions from an intentional radiator operating under these general provisions shall not exceed the level of the fundamental emission.

The emission limits shown in the above table are based on measurements employing a CISPR quasi-peak detector except for the frequency bands 9-90 kHz, 110-490 kHz.

Radiated emission limits in the above bands are based on measurements employing an average detector.

Test results - Complied with requirement.

Test Data

2.7.1 Below 30 MHz

Test equipment used (refer to List of utilized test equipment)

LP01	CL11	TR04	
------	------	------	--

Tested Date: August 11, 2008

Temperature: 25 °C
 Humidity: 38 %
 Atmos. Press: 1014 hPa

Result

There is no spurious emission with levels of more than 20 dB below the applicable limit

2.7.2 Between 30 – 1000 MHz

Test equipment used (refer to List of utilized test equipment)

BA03	CL11	PR03	TR04
------	------	------	------

Tested Date: August 8, 2008

Temperature: 26 °C
 Humidity: 33 %
 Atmos. Press: 1009 h

Operating mode: Continuous Communication (GFSK, 2441MHz: Worst configuration)

EUT position: Y-plane (Maximum position)

Measurement distance: 3 m

No.	Frequency [MHz]	Reading [dBuV]	Factor [dB/m]	Loss [dB]	Gain [dB]	Result [dBuV/m]	Limit [dBuV/m]	Margin [dB]	Antenna Polarization
1	46.459	37.2	10.1	4.5	29.7	22.1	40.0	17.9	Vert.
2	333.677	37.4	14.3	8.0	29.8	29.9	46.0	16.1	Hori.

Calculation method

The Correction Factors and RESULT are calculated as followings.

$$\text{Correction Factor [dB]} = \text{FACTOR [dB/m]} + \text{LOSS [dB]} - \text{GAIN [dB]}$$

$$\text{RESULT [dBuV/m]} = \text{READING [dBuV]} + \text{Correction Factor [dB]}$$

Sample calculation at 333.677 MHz horizontal result as follow:

$$\text{Result [dBuV/m]} = \text{Reading} + \text{C.F} = 37.4 + 14.3 + 8.0 - 29.8 = 29.9$$

$$\text{Margin} = \text{Limit} - \text{Result} = 46.0 - 29.9 = 16.1 \text{ [dBuV/m]}$$

Graphical express of test result (30MHz-1000MHz)

Antenna polarization: **Horizontal**

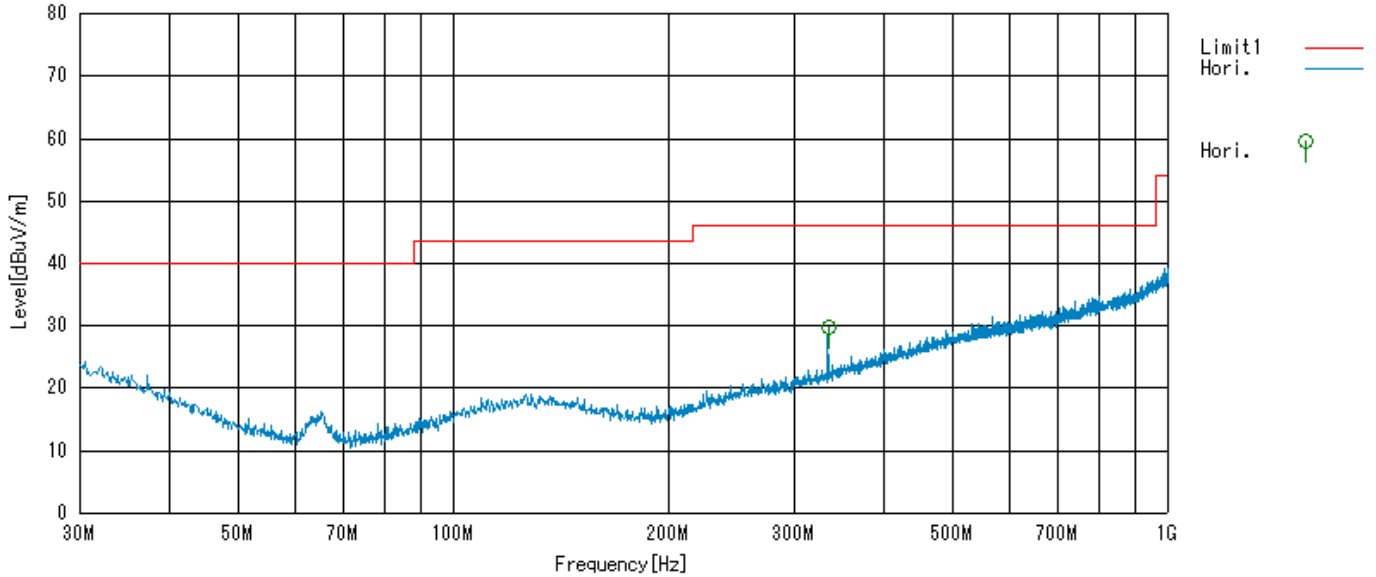

Antenna polarization: **Vertical**

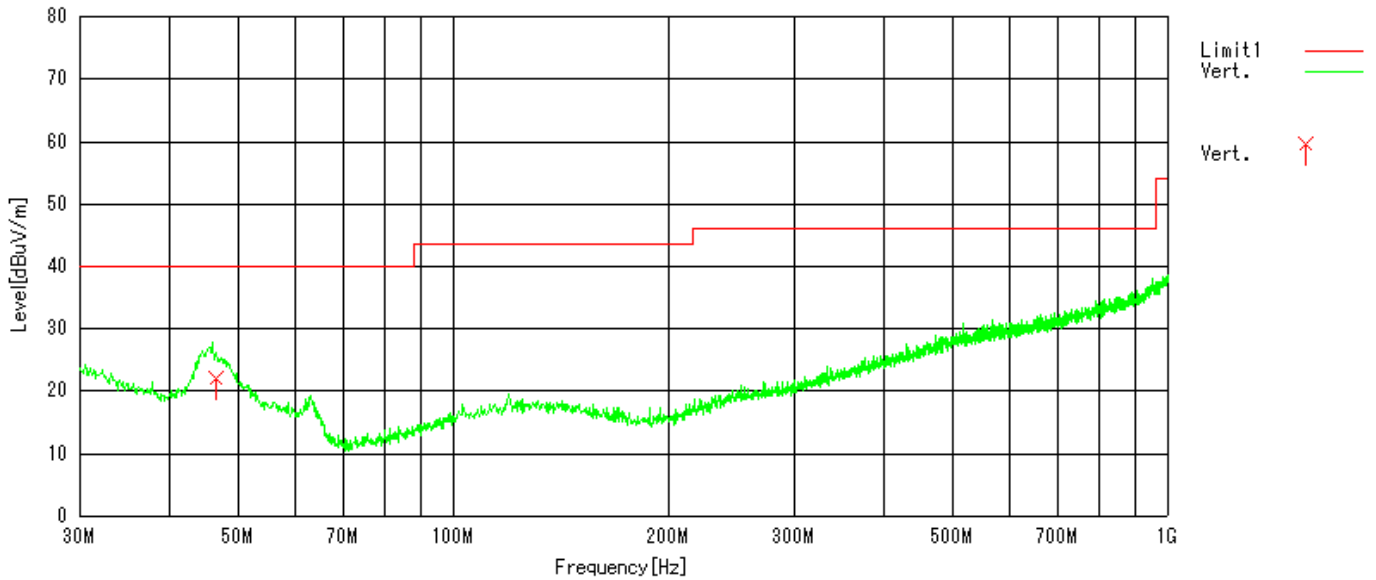

2.7.3 Above 1000 MHz

Test equipment used (refer to List of utilized test equipment)

PR10	SH01	TR06	CL23	CL24	BFR2	HPF1	DH02
------	------	------	------	------	------	------	------

Tested Date: August 10, 2008

Temperature: 26 °C
 Humidity: 38 %
 Atmos. Press: 1012 hPa

Restricted Band Edge (GFSK, Low channel, Horizontal (Worst))

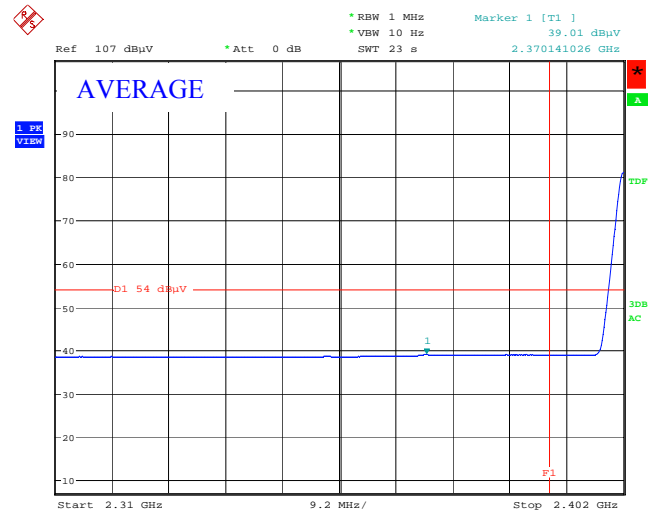
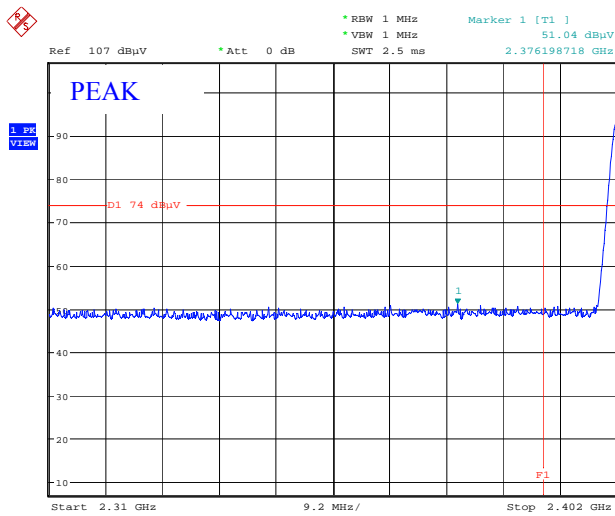

Restricted Band Edge (GFSK, High channel, Horizontal (Worst))

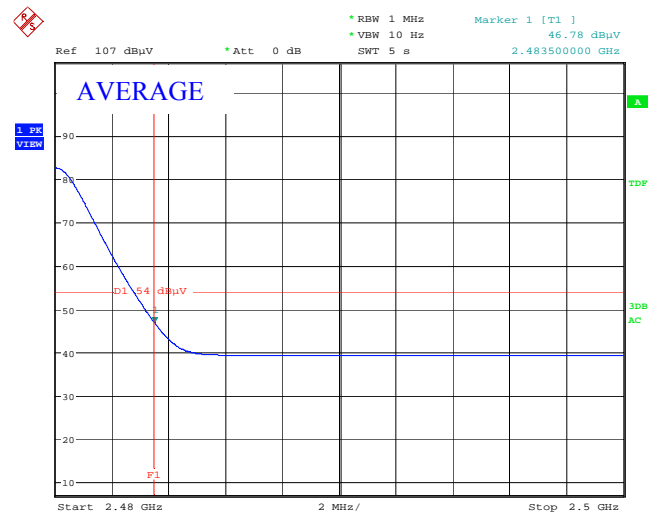
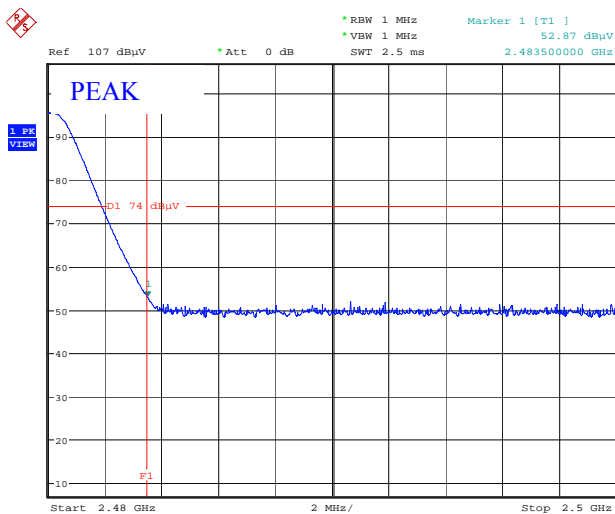

Restricted Band Edge ($\pi/4$ DQPSK, Low channel, Horizontal (Worst))

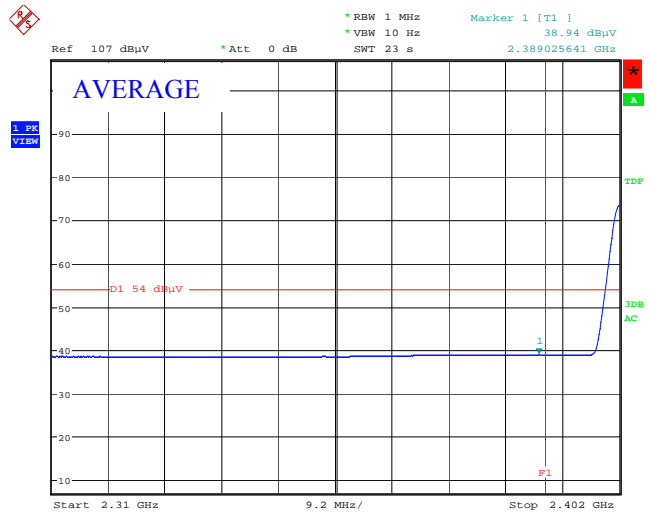
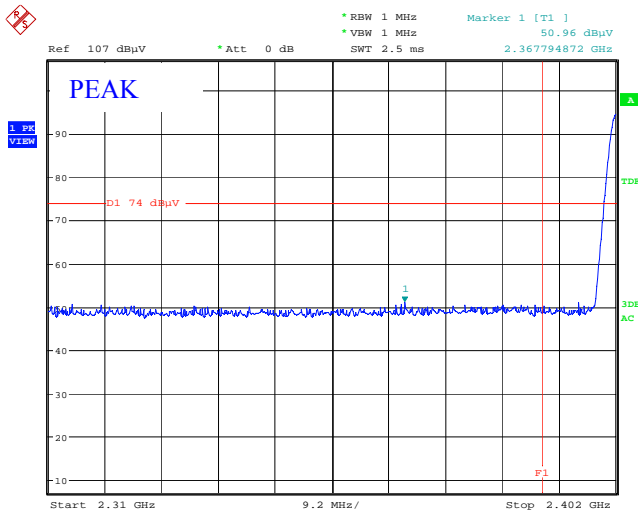

Restricted Band Edge ($\pi/4$ DQPSK, High channel, Horizontal (Worst))

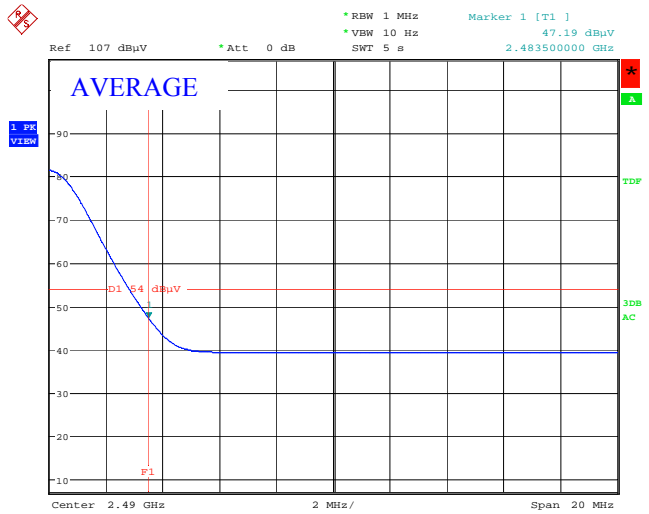
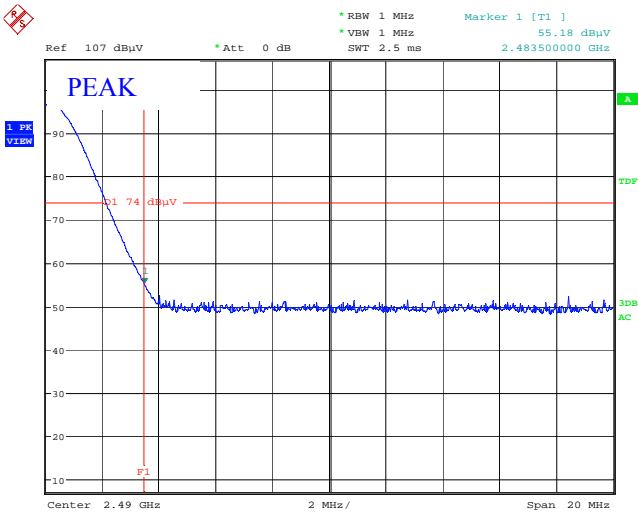

Restricted Band Edge (8DPSK, Low channel, Horizontal (Worst))

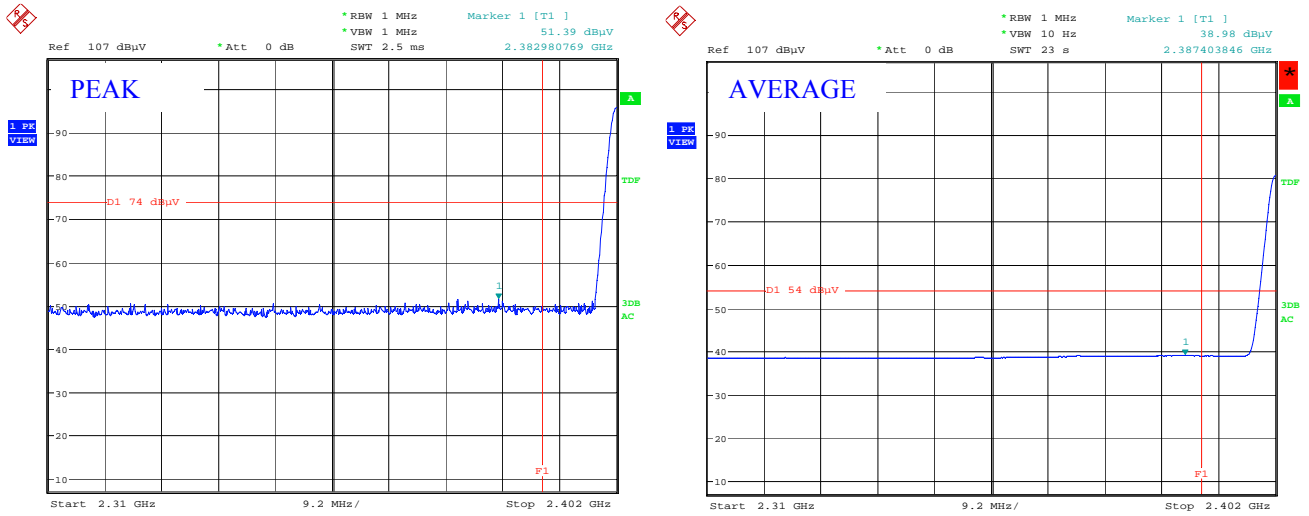

Date: 10.AUG.2008 14:18:18

Restricted Band Edge (8DPSK, High channel, Horizontal (Worst))

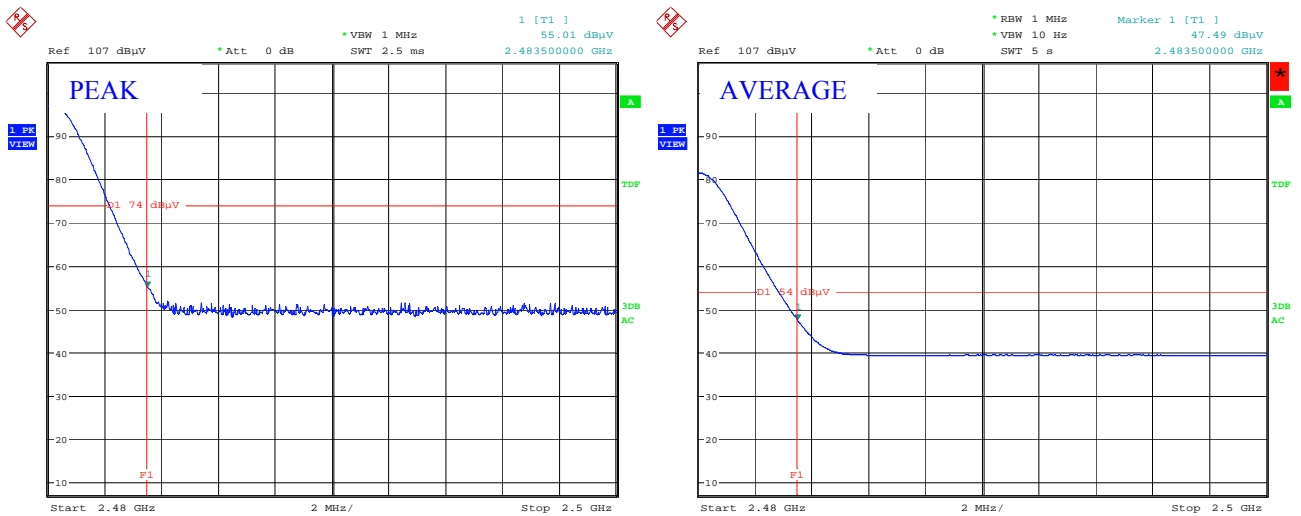

Harmonics and Spurious Emission above 1000 MHz

EUT position: Y-plane (Maximum position)
 Measurement distance: 3 m

There are no spurious emissions other than listed below;

Operating mode: Continuous Communication (GFSK)

TX CH (MHz)	Freq. (MHz)	Cable Loss (dB)	Antenna Factor (dB)	AMP Gain (dB)	Result (dBuV/m)				Limit (dBuV)		Margin (dB)	
					Ave.		Peak		Ave.	Peak	Ave.	Peak
					Hori.	Vert.	Hori.	Vert.				
0ch 2402	7206	4.8	36.3	25.5	-	-	54.13	55.08	-	73.6	-	18.52

There are no spurious emissions by M/H channel setting.

Operating mode: Continuous Communication ($\pi/4$ DQPSK)

TX CH (MHz)	Freq. (MHz)	Cable Loss (dB)	Antenna Factor (dB)	AMP Gain (dB)	Result (dBuV/m)				Limit (dBuV)		Margin (dB)	
					Ave.		Peak		Ave.	Peak	Ave.	Peak
					Hori.	Vert.	Hori.	Vert.				
0ch 2402	7206	4.8	36.3	25.5	-	-	-	57.38	-	73.6	-	16.22

There are no spurious emissions by M/H channel setting.

Operating mode: Continuous Communication (8DPSK)

TX CH (MHz)	Freq. (MHz)	Cable Loss (dB)	Antenna Factor (dB)	AMP Gain (dB)	Result (dBuV/m)				Limit (dBuV)		Margin (dB)	
					Ave.		Peak		Ave.	Peak	Ave.	Peak
					Hori.	Vert.	Hori.	Vert.				
0ch 2402	7206	4.8	36.3	25.5	-	-	-	58.07	-	73.6	-	15.53

There are no spurious emissions by M/H channel setting.

Note1: This frequency is not in the restriction band therefore this spurious emission shall be at least 20 dB below that in the 100 kHz bandwidth within the band that contains the highest level of the desired power (15.247 (d)).

The radiated carrier level of each frequency is follows (RBW = 100 kHz);

- < 93.6 dBuV/m at 2402 MHz
- < 93.5 dBuV/m at 2441 MHz
- < 94.7 dBuV/m at 2480 MHz

Calculation method

The RESULT is calculated as followings.

$$\text{RESULT [dBuV/m]} = \text{READING [dBuV]} + \text{Antenna Factor [dB/m]} + \text{Cable Loss [dB]} - \text{AMP Gain [dB]}$$

2.8 Transmitter AC power line conducted emissions

Test setup

Test setup was implemented according to the method of ANSI C63.4: 2003 clause 6 “General requirements for EUT equipment arrangements and operation” and Annex H.1 “AC power line conducted emission measurements setup”.

Test procedure

Measurement procedures were implemented according to the method of ANSI C63.4: 2003 clauses 7, clause 13.1.3 and Annex H.2 “AC power line conducted emission measurements”.

Exploratory measurements were used the spectrum analyzer to identify the frequency of the emission that has the highest amplitude relative to the limit by operating the EUT in a range of typical modes of operation, cable positions, and with a typical system equipment configuration and arrangement.

Final ac power line conducted emission measurements were performed based on the exploratory tests.

The EUT cable configuration and arrangement and mode of operation that produced the emission with the highest amplitude relative to the limit are selected for the final measurement.

When the measurement value is greater than average limitation the average detection measurements were performed.

Applicable rule and limitation

§15.207 (a) AC power line conducted limits

Frequency of Emission (MHz)	Conducted Limit (dBuV)	
	Quasi-peak	Average
0.15-0.5	66 to 56 *	56 to 46 *
0.5-5	56	46
5-30	60	50

* Decreases with the logarithm of the frequency.

The lower limit applies at the band edges.

Test equipment used (refer to List of utilized test equipment)

TR04	PL06	LN05	CL11
------	------	------	------

Test results - Complied with requirement.

Test Data

Tested Date: August 11, 2008

Temperature: 25 °C
Humidity: 38 %
Atmos. Press: 1014 hPa

Operating mode: Continuous Communication

No.	Frequency [MHz]	Reading		C.F. [dB]	Result		Limit		Margin		PHASE
		QP [dBuV]	AV [dBuV]		QP [dBuV]	AV [dBuV]	QP [dBuV]	AV [dBuV]	QP [dBuV]	AV [dBuV]	
1	0.188	42.7	30.1	0.3	43.0	30.4	64.1	54.1	21.1	23.7	L
2	0.190	41.6	29.9	0.3	41.9	30.2	64.0	54.0	22.1	23.8	N
3	1.450	34.3	28.0	0.3	34.6	28.3	56.0	46.0	21.4	17.7	N
4	1.536	35.4	29.0	0.3	35.7	29.3	56.0	46.0	20.3	16.7	L
5	1.558	34.4	28.0	0.3	34.7	28.3	56.0	46.0	21.3	17.7	N
6	1.738	30.7	24.4	0.3	31.0	24.7	56.0	46.0	25.0	21.3	L

The power line conducted emission voltage is calculated by adding the LISN factor and Cable loss attenuation from the measured reading. The calculation is as follows:

$$\text{Result} = \text{Reading} + \text{C. F}$$

where C.F = LISN Factor + Cable Loss [dB]

Sample calculation at 1.536 MHz AV result as follow:

$$\text{Result [dBuV]} = \text{Reading} + \text{C.F} = 29.0 + 0.3 = 29.3 \text{ [dBuV]}$$

$$\text{Margin} = \text{Limit} - \text{Result} = 46.0 - 29.3 = 16.7 \text{ [dBuV]}$$

Graphical express of test result (0.15 MHz-30MHz)

AC Power line conducted emission. (Phase N)

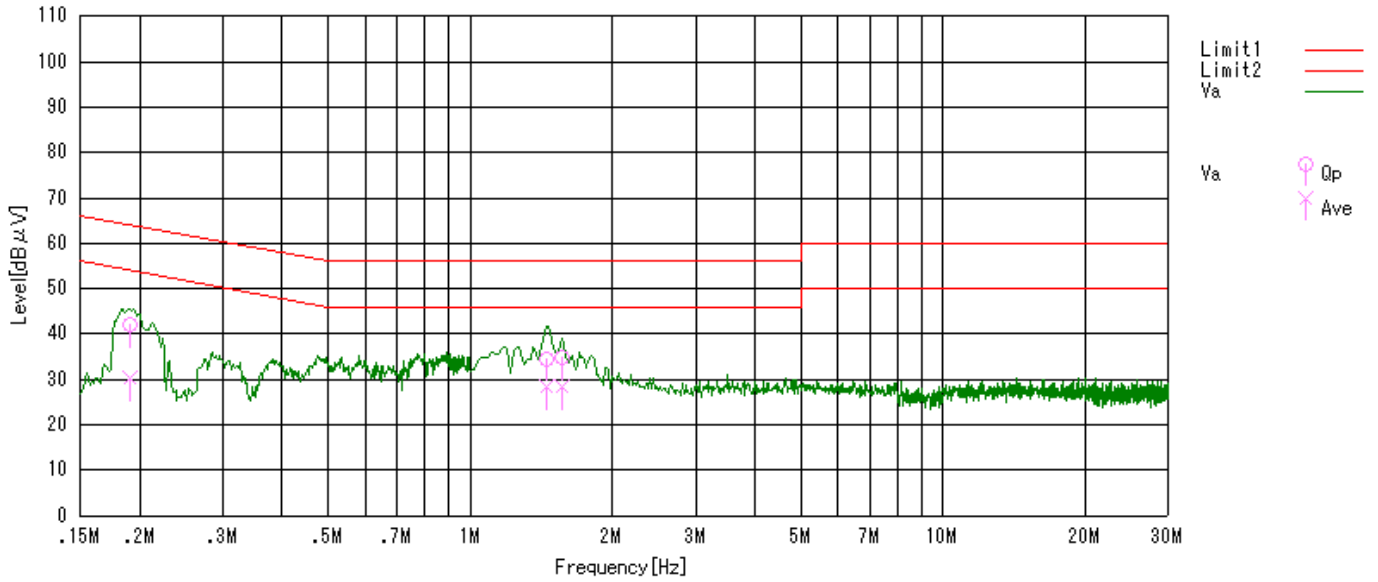

AC Power line conducted emission. (Phase L)

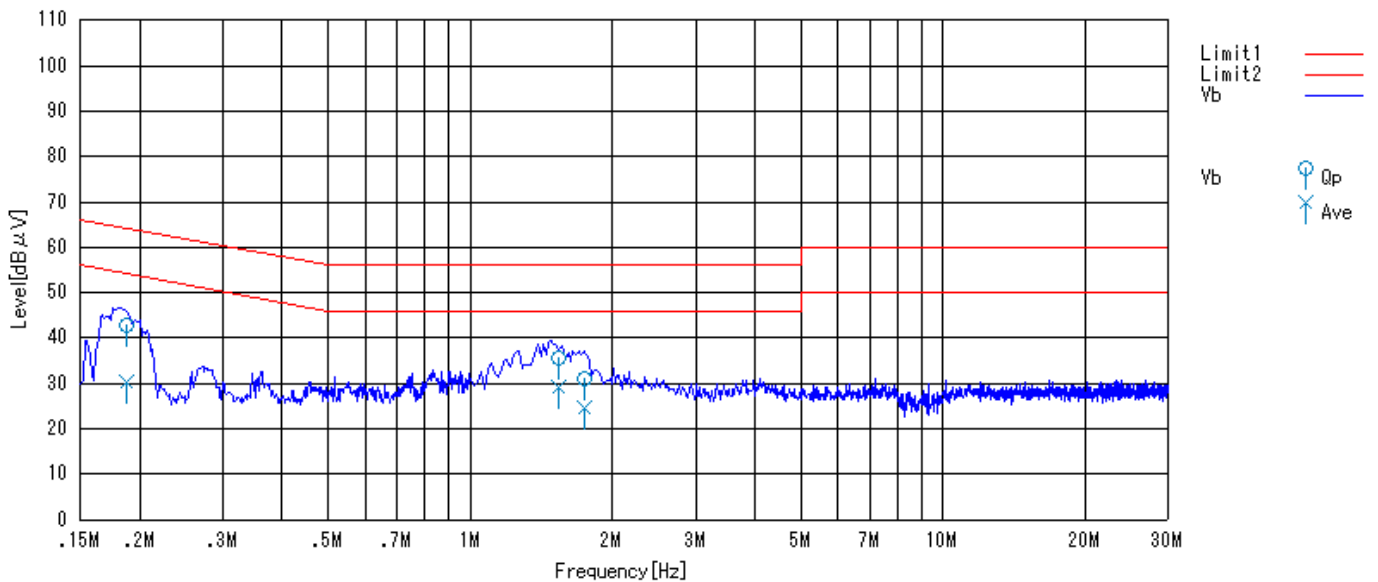

2.9 Receiver Radiated spurious emissions

Test setup - Same as clause 2.7

Test procedure - Same as clause 2.7

Applicable rule and limitation at 3m

§15.109 radiated emission limitation

Frequency (MHz)	Measurement Distance (m)	Field Strength (uV/m)	Field Strength (dBuV/m)
30 – 88	3	100	40.0
88 – 216	3	150	43.5
216 – 960	3	200	46.0
Above 960	3	500	54.0

In the emission table above, the tighter limit applies at the band edges.

The emission limits shown in the above table are based on measurements employing a CISPR quasi-peak detector.

Test results - Complied with requirement.

2.9.1 Between 30 – 1000 MHz

Test equipment used (refer to List of utilized test equipment)

BA03	CL11	PR03	TR04
------	------	------	------

Test Data

Tested Date: August 8, 2008

Temperature: 26 °C

Humidity: 33 %

Atmos. Press: 1009 hPa

Operating mode: Receiving (2441MHz: Worst configuration)

EUT position: Y-plane (Maximum position)

Measurement distance: 3 m

No.	Frequency [MHz]	Reading [dBuV]	Factor [dB/m]	Loss [dB]	Gain [dB]	Result [dBuV/m]	Limit [dBuV/m]	Margin [dB]	Antenna Polarization
1	46.379	37.9	10.1	4.5	29.7	22.8	40.0	17.2	Vert.
2	333.661	37.5	14.3	8.0	29.8	30.0	46.0	16.0	Hori.

Calculation method

The Correction Factors and RESULT are calculated as followings.

$$\text{Correction Factor [dB]} = \text{FACTOR [dB/m]} + \text{LOSS [dB]} - \text{GAIN [dB]}$$

$$\text{RESULT [dBuV/m]} = \text{READING [dBuV]} + \text{Correction Factor [dB]}$$

Sample calculation at 865.887 MHz horizontal result as follow:

$$\text{Result [dBuV/m]} = \text{Reading} + \text{C.F} = 37.5 + 14.3 + 8.0 - 29.8 = 30.0$$

$$\text{Margin} = \text{Limit} - \text{Result} = 46.0 - 30.0 = 16.0 \text{ [dBuV/m]}$$

Graphical express of test result (30MHz-1000MHz)

Antenna polarization: **Horizontal**

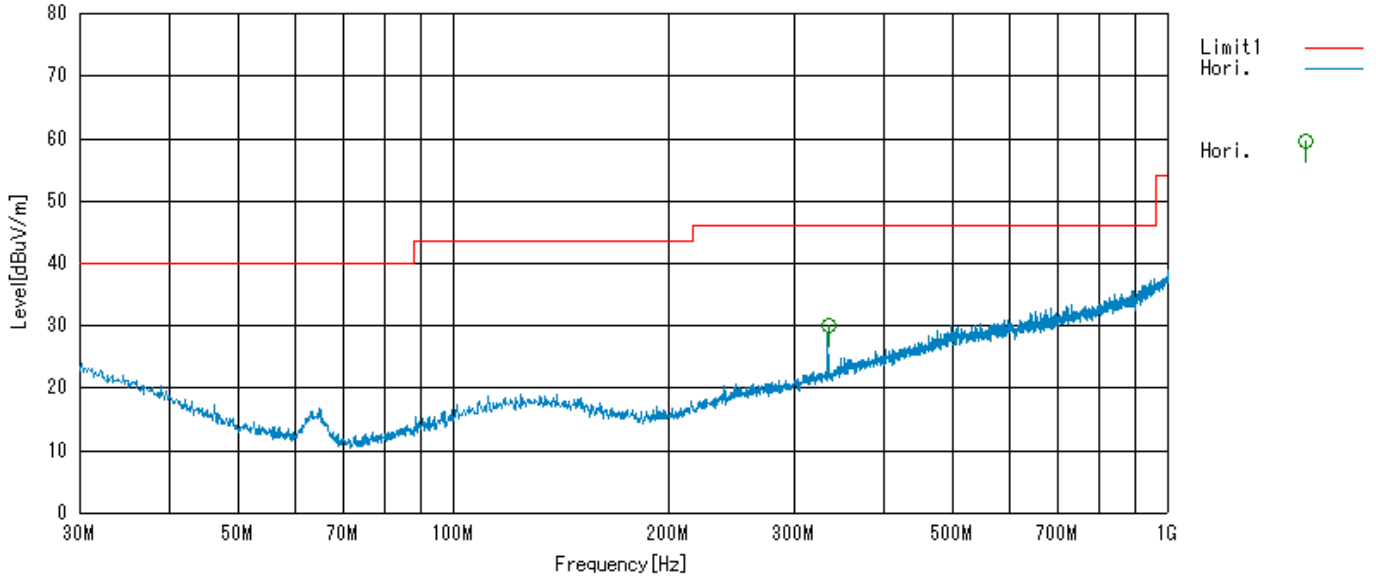

Antenna polarization: **Vertical**

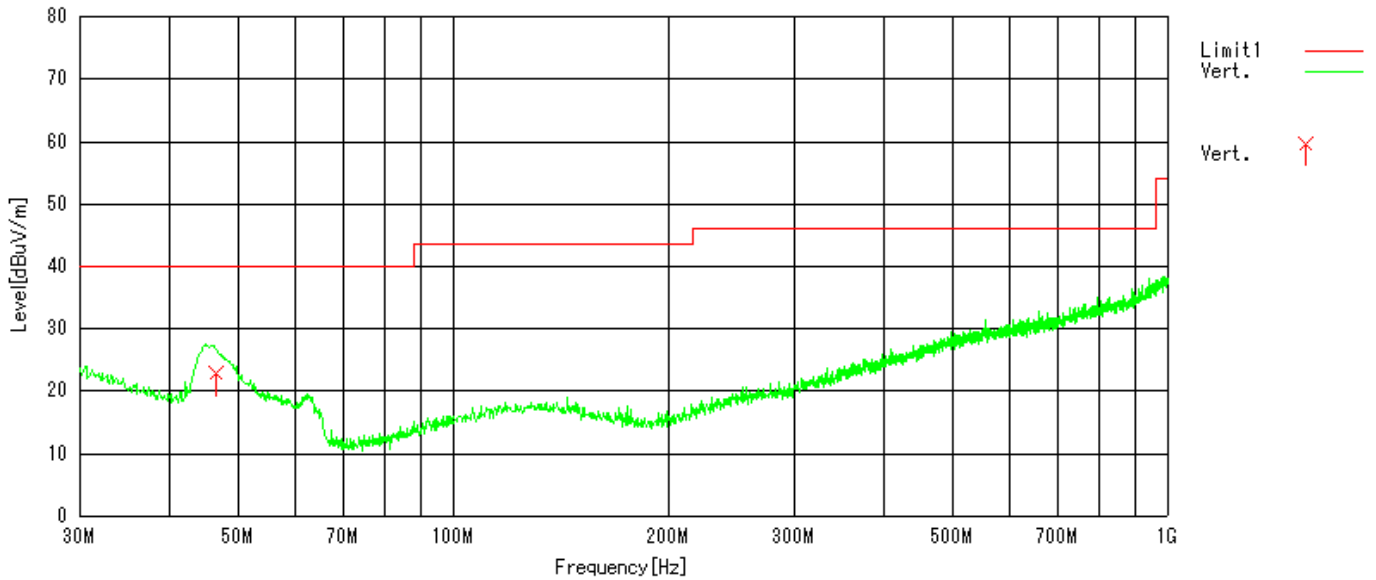

2.9.2 Above 1000 MHz

Test equipment used (refer to List of utilized test equipment)

PR10	TR06	CL23	CL24	DH02		
------	------	------	------	------	--	--

Tested Date: August 10, 2008

Temperature: 26 °C
 Humidity: 38 %
 Atmos. Press: 1012 hPa

Operating mode: Receiving (2441MHz: Worst configuration)

EUT position: X-plane (Maximum position)

Measurement distance: 3 m

There are no spurious emissions other than listed below;

No.	Frequency [MHz]	Reading [dBuV]	Factor [dB/m]	Loss [dB]	Gain [dB]	Result [dBuV/m]	Limit [dBuV/m]	Margin [dB]	Antenna Polarization
1	2404.011	37.6	28.6	2.3	27.2	41.3	54	12.7	Hori.
2	2404.011	29.7	28.6	2.3	27.2	33.4	54	20.6	Vert.

Calculation method

The RESULT is calculated as followings.

$$\text{RESULT [dBuV/m]} = \text{READING [dBuV]} + \text{Antenna Factor [dB/m]} + \text{Cable Loss [dB]} - \text{AMP Gain [dB]}$$

2.10 Receiver AC power line conducted emissions

Test setup - Same as clause 2.8

Test procedure - Same as clause 2.8

Applicable rule and limitation

§15.107 (a) AC power line conducted limits

Frequency of Emission (MHz)	Conducted Limit (dBuV)	
	Quasi-peak	Average
0.15-0.5	66 to 56 *	56 to 46 *
0.5-5	56	46
5-30	60	50

* Decreases with the logarithm of the frequency.
The lower limit applies at the band edges.

Test equipment used (refer to List of utilized test equipment)

TR04	PL06	LN05	CL11
------	------	------	------

Test results - Complied with requirement.

Test Data

Tested Date: August 11, 2008

Temperature: 25 °C
Humidity: 38 %
Atmos. Press: 1014 hPa

Operating mode: Receiving (2441MHz: Worst configuration)

No.	Frequency [MHz]	Reading		C.F. [dB]	Result		Limit		Margin		PHASE
		QP [dBuV]	AV [dBuV]		QP [dBuV]	AV [dBuV]	QP [dBuV]	AV [dBuV]	QP [dBuV]	AV [dBuV]	
1	0.186	41.7	28.4	0.3	42.0	28.7	64.2	54.2	22.2	25.5	L
2	0.191	42.4	31.8	0.3	42.7	32.1	64.0	54.0	21.3	21.9	N
3	1.414	33.6	26.1	0.3	33.9	26.4	56.0	46.0	22.1	19.6	N
4	1.414	33.1	26.6	0.3	33.4	26.9	56.0	46.0	22.6	19.1	L
5	1.522	35.0	28.7	0.3	35.3	29.0	56.0	46.0	20.7	17.0	L
6	1.702	30.7	23.2	0.3	31.0	23.5	56.0	46.0	25.0	22.5	N

The power line conducted emission voltage is calculated by adding the LISN factor and Cable loss attenuation from the measured reading. The calculation is as follows:

$$\text{Result} = \text{Reading} + \text{C. F}$$

where C.F = LISN Factor + Cable Loss [dB]

Sample calculation at 1.522MHz AV result as follow:

$$\text{Result [dBuV]} = \text{Reading} + \text{C.F} = 28.7 + 0.3 = 29.0 \text{ [dBuV]}$$

$$\text{Margin} = \text{Limit} - \text{Result} = 46.0 - 29.0 = 17.0 \text{ [dBuV]}$$

Graphical express of test result (0.15 MHz-30MHz)

AC Power line conducted emission. (Phase N)

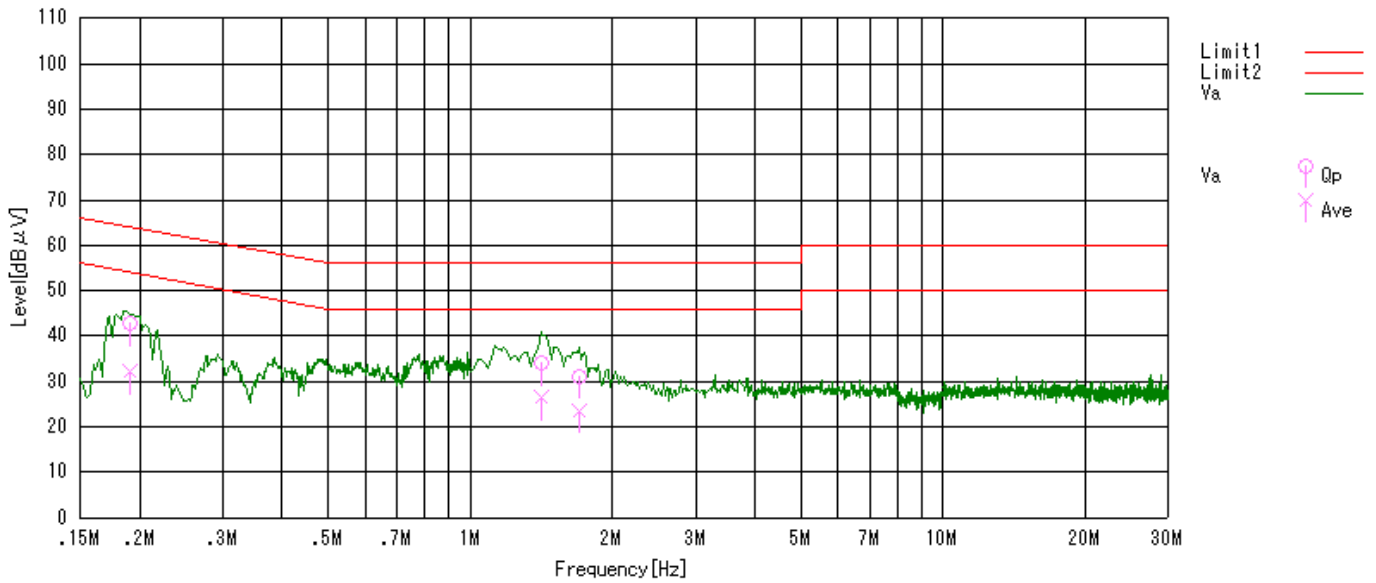

AC Power line conducted emission. (Phase L)

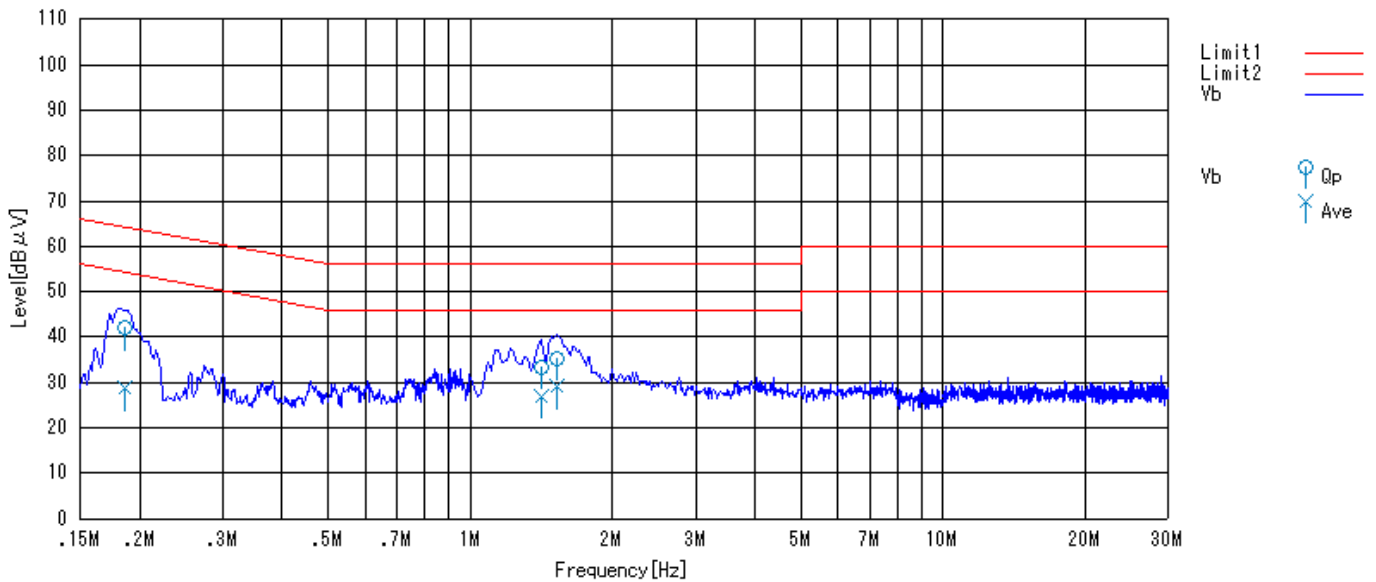

4 List of utilized test equipment/ calibration

RFT ID No.	Kind of Equipment and Precision	Manufacturer	Model No.	Serial Number	Calibration Date	Calibrated until
AC01	Anechoic Chamber (1st test room)	JSE	203397C	-	2008/07/04	2009/07/03
BA03	Biological Antenna	CHASE	CBL6111	1309	2008/05/07	2009/05/06
CL11	Antenna Cable	RFT	-	-	2008/06/11	2009/06/10
CL23	RF Cable 0.5m	SUCOFLEX	SF104PE	48773/4PE	2008/06/10	2009/06/09
CL24	RF Cable 5.0m	SUCOFLEX	SF104PE	48775/4PE	2008/06/10	2009/06/09
LN05	LISN	Kyoritsu	KNW-407	8-1773-2	2008/05/21	2009/05/20
PL06	Pulse Limiter	PMM	PL-01	0000J10109	2008/01/17	2009/01/15
PR03	Pre. Amplifier	Anritsu	MH648A	M41984	2008/05/12	2009/05/11
RP10	RF Power Amplifier	Microwave Solutions	MSD-3488601	104	2007/08/28	2008/08/26
BRF2	Band Reject Filter (Bluetooth)	MICRO TRONICS	BRM50701	024	2008/04/01	2009/03/31
HPF1	High Pass Filter (3500MHz)	TOKIMEC	TF323DCA	603	2008/06/09	2009/06/08
TR06	Test Receiver (F/W : 3.93 SP2)	Rohde & Schwarz	ESU26	100002	2007/08/15	2008/08/13
SH01	Standard Horn Antenna (18-26G)	A.H. Systems	SAS-572	208	2008/07/23	2011/07/22
TR04	Test Receiver (F/W : 3.82 SP1)	Rohde & Schwarz	ESCI	100447	2007/09/19	2008/09/17
DH02	DRG Horn Antenna	A.H. Systems	SAS-200/571	239	2007/04/20	2009/04/18

The measuring equipment, which was utilized in performing the tests documented herein, has been calibrated in accordance with the manufacturer's recommendations for utilizing calibration equipment, which is traceable to recognized national standards.