



RADIO TEST REPORT

Test Report No. : 11397594H-A

Applicant : Murata Manufacturing Co., Ltd.
Type of Equipment : UHF RFID Reader/Writer Device
Model No. : LXRFZZUAAA-032
FCC ID : VPYLXRF032
Test regulation : FCC Part 15 Subpart C: 2016
Test Result : Complied

1. This test report shall not be reproduced in full or partial, without the written approval of UL Japan, Inc.
2. The results in this report apply only to the sample tested.
3. This sample tested is in compliance with the above regulation.
4. The test results in this report are traceable to the national or international standards.
5. This test report must not be used by the customer to claim product certification, approval, or endorsement by NVLAP, NIST, or any agency of the Federal Government.
6. This test report covers Radio technical requirements. It does not cover administrative issues such as Manual or non-Radio test related Requirements. (if applicable)

Date of test: December 19, 2016 to January 6, 2017

Representative test engineer:

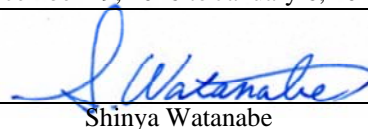
Shinya Watanabe

Engineer
Consumer Technology Division

Approved by:



Takahiro Hatakeda
Leader
Consumer Technology Division



NVLAP LAB CODE: 200572-0

This laboratory is accredited by the NVLAP LAB CODE 200572-0, U.S.A. The tests reported herein have been performed in accordance with its terms of accreditation.
*As for the range of Accreditation in NVLAP, you may refer to the WEB address,
http://japan.ul.com/resources/emc_accredited/

UL Japan, Inc.

Ise EMC Lab.

4383-326 Asama-cho, Ise-shi, Mie-ken 516-0021 JAPAN

Telephone : +81 596 24 8999

Facsimile : +81 596 24 8124

13-EM-F0429

CONTENTS	PAGE
SECTION 1: Customer information.....	4
SECTION 2: Equipment under test (E.U.T.).....	4
SECTION 3: Test specification, procedures & results.....	5
SECTION 4: Operation of E.U.T. during testing.....	8
SECTION 5: Conducted Emission.....	11
SECTION 6: Radiated Spurious Emission	12
SECTION 7: Antenna Terminal Conducted Tests.....	13
APPENDIX 1: Test data	14
Conducted Emission	14
20dB Bandwidth and Carrier Frequency Separation.....	20
Number of Hopping Frequency	22
Dwell time.....	23
Maximum Peak Output Power	25
Average Output Power	26
Radiated Spurious Emission	28
Conducted Spurious Emission	52
Conducted Emission Band Edge compliance	55
99% Occupied Bandwidth	56
APPENDIX 2: Test instruments	57
APPENDIX 3: Photographs of test setup	58
Conducted Emission	58
Radiated Spurious Emission	61
Worst Case Position	61

SECTION 1: Customer information

Company Name : Murata Manufacturing Co., Ltd.
Address : 10-1, Higashikotari 1-chome, Nagaokakyo-shi, Kyoto 617-8555 Japan
Telephone Number : +81-75-955-7329
Facsimile Number : +81-75-955-7332
Contact Person : Yoichi Saito

SECTION 2: Equipment under test (E.U.T.)

2.1 Identification of E.U.T.

Type of Equipment : UHF RFID Reader/Writer Device
Model No. : LXRFFZZUAAA-032
Serial No. : Refer to Section 4, Clause 4.2
Rating : DC 5.0 V
Receipt Date of Sample : December 16, 2016
Country of Mass-production : Japan
Condition of EUT : Production prototype
(Not for Sale: This sample is equivalent to mass-produced items.)
Modification of EUT : No Modification by the test lab

2.2 Product Description

Model: LXRFFZZUAAA-032 (referred to as the EUT in this report) is a UHF RFID Reader/Writer Device.

Radio Specification

Radio Type : Transceiver
Frequency of Operation : 902.75 MHz to 927.25 MHz
Modulation : FHSS
Power Supply (radio part input) : DC 3.3 V
Antenna type : Near field Loop Antenna [LXRFFZZUCCA-036]
Circular Polarized Antenna [LXRFFZZUCCA-034]
Cable Antenna (1m) [LXRFFZZUCCA-040]
Cable Antenna (2m) [LXRFFZZUCCA-038]
Antenna Gain : Near field Loop Antenna without cable: -18.0 dBi
Near field Loop Antenna with 0.216 m (8.5 inch) cable: -18.3 dBi
Circular Polarized Antenna without cable: -2.6 dBi
Circular Polarized Antenna with 0.216 m (8.5 inch) cable: -2.9 dBi
Cable Antenna (1m): -4.7 dBi
Cable Antenna (2m): -4.7 dBi
Clock frequency : 19.2 MHz

SECTION 3: Test specification, procedures & results

3.1 Test Specification

Test Specification : FCC Part 15 Subpart C
FCC Part 15 final revised on November 14, 2016 and effective December 14, 2016

Title : FCC 47CFR Part15 Radio Frequency Device Subpart C Intentional Radiators
Section 15.207 Conducted limits
Section 15.247 Operation within the bands 902-928MHz,
2400-2483.5MHz, and 5725-5850MHz

* The revision on November 14, 2016, does not affect the test specification applied to the EUT.

* Also the EUT complies with FCC Part 15 Subpart B.

3.2 Procedures and results

Item	Test Procedure	Specification	Worst Margin	Results	Remarks
Conducted Emission	FCC: ANSI C63.10-2013 6. Standard test methods IC: RSS-Gen 8.8	FCC: Section 15.207 IC: RSS-Gen 8.8	QP 13.1 dB, 0.19286 MHz, L (Loop Antenna without cable) AV 17.5 dB, 0.19680 MHz, N (Loop Antenna without cable)	Complied	-
Carrier Frequency Separation	FCC: FCC Public Notice DA 00-705 IC: -	FCC: Section15.247(a)(1) IC: RSS-247 5.1 (2)	See data.	Complied	Conducted
20dB Bandwidth	FCC: FCC Public Notice DA 00-705 IC: -	FCC: Section15.247(a)(1) IC: RSS-247 5.1 (1)		Complied	Conducted
Number of Hopping Frequency	FCC: FCC Public Notice DA 00-705 IC: -	FCC: Section15.247(a)(1)(i) IC: RSS-247 5.1 (3)		Complied	Conducted
Dwell time	FCC: FCC Public Notice DA 00-705 IC: -	FCC: Section15.247(a)(1)(i) IC: RSS-247 5.1 (3)		Complied	Conducted
Maximum Peak Output Power	FCC: FCC Public Notice DA 00-705 IC: RSS-Gen 6.12	FCC: Section15.247(b)(2) IC: RSS-247 5.4 (1)		Complied	Conducted
Spurious Emission & Band Edge Compliance	FCC: FCC Public Notice DA 00-705 IC: RSS-Gen 6.13	FCC: Section15.247(d) IC: RSS-247 5.5 RSS-Gen 8.9 RSS-Gen 8.10		2.9 dB 1854.500 MHz, AV, Horizontal (Patch Antenna without cable)	Complied

Note: UL Japan, Inc.'s EMI Work Procedures No. 13-EM-W0420 and 13-EM-W0422.

*1) Radiated test was selected over 30 MHz based on section 15.247(d).

* In case any questions arise about test procedure, ANSI C63.10: 2013 is also referred.

FCC Part 15.31 (e)

This EUT provides stable voltage (DC 3.3 V) constantly to RF Module regardless of input voltage. Therefore, this EUT complies with the requirement.

FCC Part 15.203 Antenna requirement

The EUT has a unique coupling/antenna connector (RP-SMA). Therefore the equipment complies with the requirement of 15.203.

UL Japan, Inc.

Ise EMC Lab.

4383-326 Asama-cho, Ise-shi, Mie-ken 516-0021 JAPAN

Telephone : +81 596 24 8999

Facsimile : +81 596 24 8124

3.3 Addition to standard

Item	Test Procedure	Specification	Worst margin	Results	Remarks
99% Occupied Bandwidth	IC: RSS-Gen 6.6	IC: -	N/A	-	Conducted

Other than above, no addition, exclusion nor deviation has been made from the standard.

3.4 Uncertainty

EMI

The following uncertainties have been calculated to provide a confidence level of 95 % using a coverage factor $k = 2$.
Ise EMC Lab.

Antenna terminal test Uncertainty (+/-)							
Power meter		Conducted emission and Power density			Conducted emission		Channel power
Below 1 GHz	Above 1 GHz	Below 1 GHz	1 GHz - 3 GHz	3 GHz - 18 GHz	18 GHz - 26.5 GHz	26.5 GHz - 40 GHz	
0.9 dB	1.0 dB	1.4 dB	1.5 dB	2.8 dB	2.8 dB	2.9 dB	2.6 dB

Frequency range	Conducted emission using AMN(LISN) (+/-)
0.009 – 0.15MHz	3.5 dB
0.15 – 30MHz	3.0 dB

Test distance	Radiated emission (+/-) 9 kHz - 30 MHz
3m	3.8 dB
10m	3.7 dB

Polarity	Radiated emission (Below 1GHz)			
	(3 m*) (+/-)		(10 m*) (+/-)	
	30 – 200 MHz	200 – 1000MHz	30 – 200 MHz	200 – 1000MHz
Horizontal	5.0 dB	5.3 dB	5.0 dB	5.0 dB
Vertical	4.7 dB	5.9 dB	5.0 dB	5.1 dB

Radiated emission (Above 1GHz)				
(3 m*) (+/-)		(1 m*) (+/-)		(10 m*) (+/-)
1 – 6GHz	6 – 18GHz	10 – 26.5 GHz	26.5 – 40GHz	1 -18 GHz
5.2 dB	5.4 dB	5.5 dB	5.5 dB	5.4 dB

*Measurement distance

Conducted Emission test

The data listed in this test report has enough margin, more than the site margin.

Radiated emission test

The data listed in this report meets the limits unless the uncertainty is taken into consideration.

3.5 Test Location

UL Japan, Inc. Ise EMC Lab. *NVLAP Lab. code: 200572-0
4383-326 Asama-cho, Ise-shi, Mie-ken 516-0021 JAPAN
Telephone: +81 596 24 8999, Facsimile: +81 596 24 8124

Test site	IC Registration Number	Width x Depth x Height (m)	Size of reference ground plane (m) / horizontal conducting plane	Other rooms	Maximum measurement distance
No.1 semi-anechoic chamber	2973C-1	19.2 x 11.2 x 7.7	7.0 x 6.0	No.1 Power source room	10 m
No.2 semi-anechoic chamber	2973C-2	7.5 x 5.8 x 5.2	4.0 x 4.0	-	3 m
No.3 semi-anechoic chamber	2973C-3	12.0 x 8.5 x 5.9	6.8 x 5.75	No.3 Preparation room	3 m
No.3 shielded room	-	4.0 x 6.0 x 2.7	N/A	-	-
No.4 semi-anechoic chamber	2973C-4	12.0 x 8.5 x 5.9	6.8 x 5.75	No.4 Preparation room	3 m
No.4 shielded room	-	4.0 x 6.0 x 2.7	N/A	-	-
No.5 semi-anechoic chamber	-	6.0 x 6.0 x 3.9	6.0 x 6.0	-	-
No.6 shielded room	-	4.0 x 4.5 x 2.7	4.0 x 4.5	-	-
No.6 measurement room	-	4.75 x 5.4 x 3.0	4.75 x 4.15	-	-
No.7 shielded room	-	4.7 x 7.5 x 2.7	4.7 x 7.5	-	-
No.8 measurement room	-	3.1 x 5.0 x 2.7	N/A	-	-
No.9 measurement room	-	8.8 x 4.6 x 2.8	2.4 x 2.4	-	-
No.11 measurement room	-	6.2 x 4.7 x 3.0	4.8 x 4.6	-	-

3.6 Test data, Test instruments, and Test set up

Refer to APPENDIX.

SECTION 4: Operation of E.U.T. during testing

4.1 Operating Mode(s)

Transmitting (Tx): Payload: PRBS9

Details of Operating Mode(s)

Test Item	Mode	Tested frequency
Conducted Emission, Spurious Emission (Conducted/Radiated), 20dB Bandwidth, Maximum Peak Output Power	Tx (Hopping Off)	902.75 MHz 914.75 MHz 927.25 MHz
Number of Hopping Frequency, Carrier Frequency Separation	Tx (Hopping On)	-
Dwell time	Tx (Hopping On)	902.75 MHz 914.75 MHz 927.25 MHz
Band Edge Compliance (Conducted)	Tx (Hopping On / Hopping Off)	-
99% Occupied Bandwidth	Tx (Hopping Off)	902.75 MHz 914.75 MHz 927.25 MHz
	Tx (Hopping On)	-

*EUT has the power settings by the software as follows;
Power settings: 25 dBm
Software: continuous emission test: cw_low_ch.exe, cw_mid_ch.exe, cw_high_ch.exe
hopping emission test: hopping.exe
communication operation test: ff_low_ch.exe, ff_mid_ch.exe, ff_high_ch.exe, hopping.exe

*This setting of software is the worst case.
Any conditions under the normal use do not exceed the condition of setting.
In addition, end users cannot change the settings of the output power of the product.
The carrier level and noise levels were confirmed with or without RF cable and the test was made at the worst case.

4.2 Configuration and peripherals

< Near Field Loop Antenna >

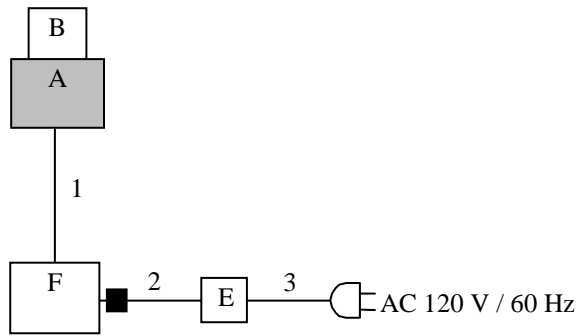

■ : Standard Ferrite Core

< Circular Polarized Antenna >

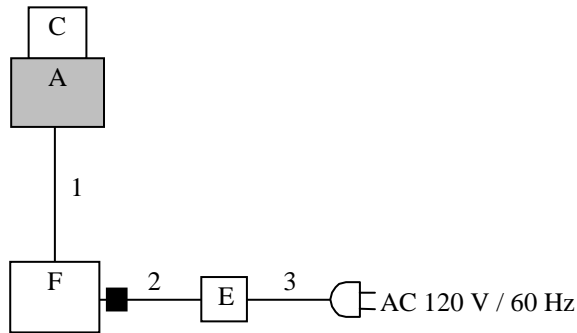

■ : Standard Ferrite Core

< Cable Antenna >

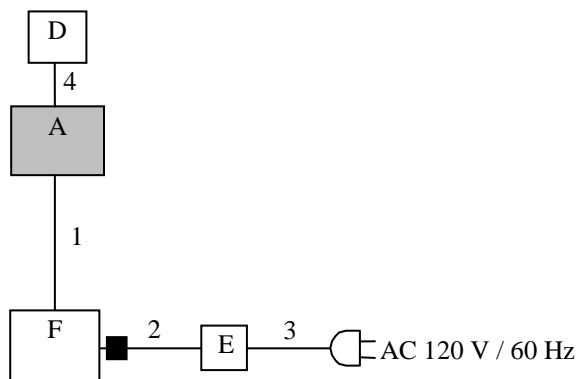

■ : Standard Ferrite Core

* Cabling and setup(s) were taken into consideration and test data was taken under worse case conditions.

Description of EUT and Support equipment

No.	Item	Model number	Serial number	Manufacturer	Remarks
A	UHF RFID Reader/Writer Device	LXRFZZUAAA-032	1650US	Murata Manufacturing Co., Ltd.	EUT
B	Near Field Loop Antenna	LXRFZZUCCA-036	-	-	*1)
C	Circular Polarized Antenna	LXRFZZUCCA-034	-	-	*1)
D	Cable Antenna (1m)	LXRFZZUCCA-040	-	-	*2)
E	AC Adapter	CF-AA6402AM1	6402AM111921184A	Panasonic	-
F	Note PC	CF-N9KWCPJS	OJKSA21577	Panasonic	-

*1) The test was performed with “without cable” which was the worst condition.

*2) Since Cable Antenna (1m) and Cable Antenna (2m) have the same antenna gain, test was performed with Cable Antenna (1m) that had the worst condition at conducting pre-test.

List of cables used

No.	Name	Length (m)	Shield		Remarks
			Cable	Connector	
1	USB Cable	2.0	Shielded	Shielded	-
2	DC Cable	1.0	Unshielded	Unshielded	-
3	AC Cable	1.0	Unshielded	Unshielded	-
4	Antenna Cable	1.0	Shielded	Shielded	-

UL Japan, Inc.

Ise EMC Lab.

4383-326 Asama-cho, Ise-shi, Mie-ken 516-0021 JAPAN

Telephone : +81 596 24 8999

Facsimile : +81 596 24 8124

SECTION 5: Conducted Emission

Test Procedure and conditions

EUT was placed on a urethane platform of nominal size, 1.0 m by 1.5 m, raised 0.8m above the conducting ground plane.

The rear of tabletop was located 40 cm to the vertical conducting plane. The rear of EUT, including peripherals aligned and flushed with rear of tabletop. All other surfaces of tabletop were at least 80 cm from any other grounded conducting surface. EUT was located 80 cm from a Line Impedance Stabilization Network (LISN) / Artificial mains Network (AMN) and excess AC cable was bundled in center.

For the tests on EUT with other peripherals (as a whole system)

I/O cables that were connected to the peripherals were bundled in center. They were folded back and forth forming a bundle 30 cm to 40 cm long and were hanged at a 40 cm height to the ground plane. All unused 50 ohm connectors of the LISN (AMN) were resistivity terminated in 50 ohm when not connected to the measuring equipment.

The AC Mains Terminal Continuous disturbance Voltage has been measured with the EUT in a Semi Anechoic Chamber.

The EUT was connected to a LISN (AMN).

An overview sweep with peak detection has been performed.

The test results and limit are rounded off to one decimal place, so some differences might be observed.

Detector	: QP and CISPR AV
Measurement range	: 0.15 MHz - 30 MHz
Test data	: APPENDIX
Test result	: Pass

SECTION 6: Radiated Spurious Emission

Test Procedure

[For below 1 GHz]

EUT was placed on a urethane platform of nominal size, 0.5 m by 1.0 m, raised 0.8 m above the conducting ground plane. The Radiated Electric Field Strength has been measured in a Semi Anechoic Chamber with a ground plane.

[For above 1 GHz]

EUT was placed on a urethane platform of nominal size, 0.5 m by 0.5 m, raised 1.5 m above the conducting ground plane.

The Radiated Electric Field Strength has been measured in a Semi Anechoic Chamber with absorbent materials lined on a ground plane.

The height of the measuring antenna varied between 1 and 4 m and EUT was rotated a full revolution in order to obtain the maximum value of the electric field strength.

The measurements were performed for both vertical and horizontal antenna polarization with the Test Receiver, or the Spectrum Analyzer.

The measurements were made with the following detector function of the test receiver and the Spectrum analyzer (in linear mode).

The test was made with the detector (RBW/VBW) in the following table.

When using Spectrum analyzer, the test was made with adjusting span to zero by using peak hold.

Test Antennas are used as below;

Frequency	30 MHz to 200 MHz	200 MHz to 1 GHz	Above 1 GHz
Antenna Type	Biconical	Logperiodic	Horn

In any 100 kHz bandwidth outside the restricted band in which the spread spectrum intentional radiator is operating, the radio frequency power that is produced by the intentional radiator confirmed 20 dB below that in the 100 kHz bandwidth within the band that contains the highest level of the desired power, based on a radiated measurement.

20 dBc was applied to the frequency over the limit of FCC 15.209 / Table 4 of RSS-Gen 8.9 (IC) and outside the restricted band of FCC15.205 / Table 6 of RSS-Gen 8.10 (IC).

Frequency	Below 1 GHz	Above 1 GHz		20 dBc
Instrument used	Test Receiver	Spectrum Analyzer		Spectrum Analyzer
Detector	QP	PK	AV	PK
IF Bandwidth	BW 120 kHz	RBW: 1 MHz VBW: 3 MHz	RBW: 1 MHz VBW: 10 Hz *1)	RBW: 100 kHz VBW: 300 kHz
Test Distance	3 m	3.75 m*2) (1 GHz - 10 GHz)		3.75 m*2) (1 GHz - 10 GHz)

*1) Although DA 00-705 accepts VBW = 10 Hz for AV measurements, it was confirmed that superfluous smoothing was not performed.

*2) Distance Factor: $20 \times \log(3.75 \text{ m}/3.0 \text{ m}) = 1.94 \text{ dB}$

- The carrier level and noise levels were confirmed at each position of X, Y and Z axes of EUT and with or without RF cable to see the position of maximum noise, and the test was made at the position that has the maximum noise.

The test results and limit are rounded off to one decimal place, so some differences might be observed.

Measurement range : 30 MHz - 10 GHz
Test data : APPENDIX
Test result : Pass

UL Japan, Inc.

Ise EMC Lab.

4383-326 Asama-cho, Ise-shi, Mie-ken 516-0021 JAPAN

Telephone : +81 596 24 8999

Facsimile : +81 596 24 8124

SECTION 7: Antenna Terminal Conducted Tests

Test Procedure

The tests were made with below setting connected to the antenna port.

Test	Span	RBW	VBW	Sweep time	Detector	Trace	Instrument used
20dB Bandwidth	500 kHz	10 kHz	30 kHz	Auto	Peak	Max Hold	Spectrum Analyzer
99% Occupied Bandwidth *1)	Enough width to display emission skirts	1 to 5 % of OBW	Three times of RBW	Auto	Peak	Max Hold	Spectrum Analyzer
Maximum Peak Output Power	-	-	-	Auto	Peak Average *2)	-	Power Meter (Sensor: 50MHz BW)
Carrier Frequency Separation	2 MHz	30 kHz	100 kHz	Auto	Peak	Max Hold	Spectrum Analyzer
Number of Hopping Frequency	30 MHz	300 kHz	1 MHz	Auto	Peak	Max Hold	Spectrum Analyzer
Dwell Time	Zero Span	100 kHz, 1 MHz	300 kHz, 3 MHz	As necessary capture the entire dwell time per hopping channel	Peak	Clear Write	Spectrum Analyzer
Conducted Spurious Emission *3)	9 kHz to 150 kHz	200 Hz	620 Hz	Auto	Peak	Max Hold	Spectrum Analyzer
	150 kHz to 30 MHz	9.1 kHz	27 kHz				
	30 MHz to 25 GHz	100 kHz	300 kHz				
Conducted Spurious Emission Band Edge compliance	10 MHz	100 kHz	300 kHz	Auto	Peak	Max Hold	Spectrum Analyzer

*1) Peak hold was applied as Worst-case measurement.

*2) Reference data

*3) In the frequency range below 30MHz, RBW was narrowed to separate the noise contents.

Then, wide-band noise near the limit was checked separately, however the noise was not detected as shown in the chart.

(9 kHz -150 kHz: RBW = 200 Hz, 150 kHz - 30 MHz: RBW = 9.1 kHz)

The test results and limit are rounded off to two decimals place, so some differences might be observed.

Test data : APPENDIX
Test result : Pass

APPENDIX 1: Test data

Conducted Emission
Near field Loop Antenna without cable

DATA OF CONDUCTED EMISSION TEST

UL Japan, Inc. Ise EMC Lab. No23 Semi Anechoic Chamber
Date : 2016/12/22

Report No. : 11397594H
Temp./Humi. : 20deg. C / 45% RH
Engineer : Ryota Yamanaka

Mode / Remarks : Tx_Lch_Loop Ant

LIMIT : FCC15.107(a) QP ClassB
FCC15.107(a) AV ClassB

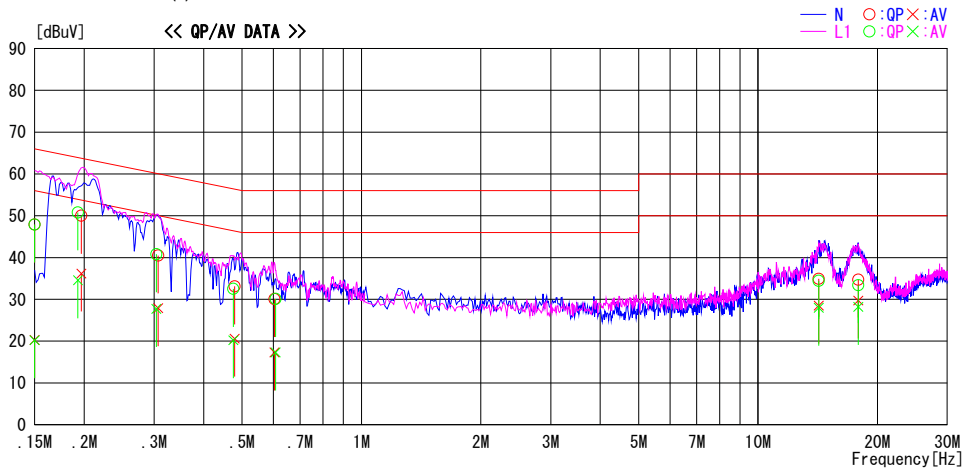

Frequency [MHz]	Reading Level		Corr. Factor [dB]	Results		Limit		Margin		Phase	Comment
	QP [dBuV]	AV [dBuV]		QP [dBuV]	AV [dBuV]	QP [dBuV]	AV [dBuV]	QP [dB]	AV [dB]		
0.15000	34.7	7.1	13.2	47.9	20.3	66.0	56.0	18.1	35.7	N	
0.15000	34.7	7.0	13.2	47.9	20.2	66.0	56.0	18.1	35.8	L	
0.19286	37.6	21.4	13.2	50.8	34.6	63.9	53.9	13.1	19.3	L	
0.19680	36.8	23.0	13.2	50.0	36.2	63.7	53.7	13.7	17.5	N	
0.30396	27.6	14.5	13.2	40.8	27.7	60.1	50.1	19.3	22.4	L	
0.30732	27.3	14.7	13.2	40.5	27.9	60.0	50.0	19.5	22.1	N	
0.47524	19.3	7.0	13.2	32.5	20.2	56.4	46.4	23.9	26.2	L	
0.47900	19.9	7.4	13.2	33.1	20.6	56.4	46.4	23.3	25.8	N	
0.60388	16.8	4.0	13.3	30.1	17.3	56.0	46.0	25.9	28.7	N	
0.60804	16.8	4.0	13.3	30.1	17.3	56.0	46.0	25.9	28.7	L	
14.22058	20.4	14.0	14.5	34.9	28.5	60.0	50.0	25.1	21.5	N	
14.22213	19.9	13.5	14.5	34.4	28.0	60.0	50.0	25.6	22.0	L	
17.89660	20.0	15.0	14.7	34.7	29.7	60.0	50.0	25.3	20.3	N	
17.89700	18.7	13.5	14.7	33.4	28.2	60.0	50.0	26.6	21.8	L	

Conducted Emission

Test place : Ise EMC Lab. No.2 Semi Anechoic Chamber
Report No. : 11397594H
Date : December 22, 2016
Temperature / Humidity : 20 deg. C / 45 % RH
Engineer : Ryota Yamanaka
Mode : Near field Loop Antenna without cable

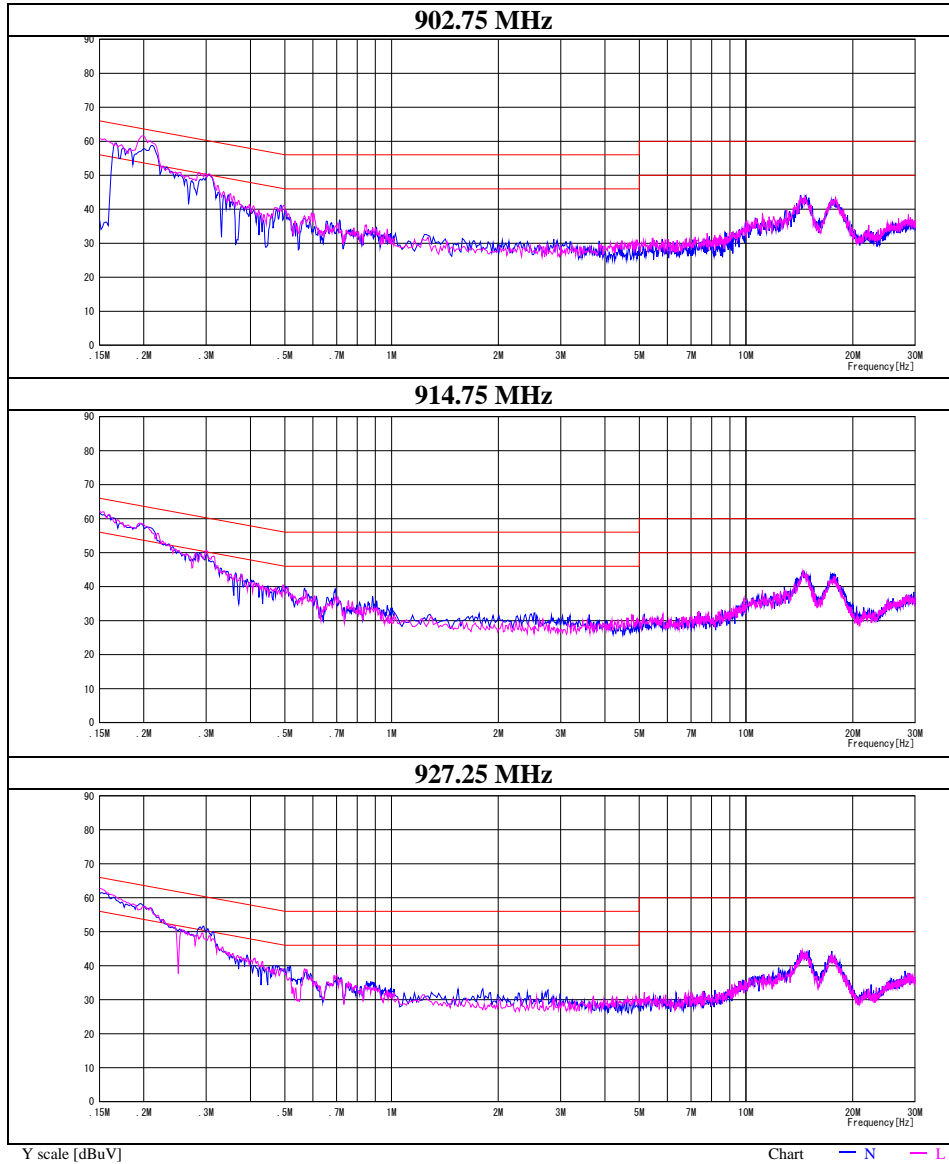

Conducted Emission
Circular Polarized Antenna without cable

DATA OF CONDUCTED EMISSION TEST

UL Japan, Inc. Ise EMC Lab. No.2 Semi Anechoic Chamber
Date : 2016/12/22

Report No. : 11397594H
Temp./Humi. : 20deg. C / 45% RH
Engineer : Ryota Yamanaka

Mode / Remarks : Tx_Lch_Patch Ant

LIMIT : FCC15.107(a) QP ClassB
FCC15.107(a) AV ClassB

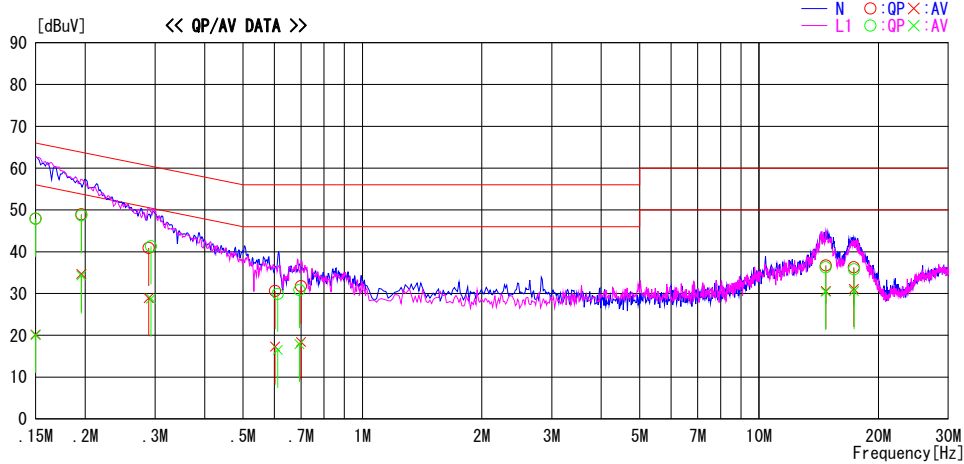

Frequency [MHz]	Reading Level		Corr. Factor	Results		Limit		Margin		Phase	Comment
	QP [dBuV]	AV [dBuV]		QP [dBuV]	AV [dBuV]	QP [dBuV]	AV [dBuV]	QP [dB]	AV [dB]		
0.15000	34.7	7.0	13.2	47.9	20.2	66.0	56.0	18.1	35.8	N	
0.15000	34.7	6.9	13.2	47.9	20.1	66.0	56.0	18.1	35.9	L	
0.19565	35.7	21.5	13.2	48.9	34.7	63.8	53.8	14.9	19.1	N	
0.19573	35.5	21.1	13.2	48.7	34.3	63.8	53.8	15.1	19.5	L	
0.28920	27.7	15.7	13.2	40.9	28.9	60.5	50.5	19.6	21.6	N	
0.29304	28.1	15.6	13.2	41.3	28.8	60.4	50.4	19.1	21.6	L	
0.60182	17.3	4.0	13.3	30.6	17.3	56.0	46.0	25.4	28.7	N	
0.61150	16.6	3.2	13.3	29.9	16.5	56.0	46.0	26.1	29.5	L	
0.69400	17.5	4.6	13.3	30.8	17.9	56.0	46.0	25.2	28.1	L	
0.70000	18.4	5.1	13.3	31.7	18.4	56.0	46.0	24.3	27.6	N	
14.71690	21.8	15.9	14.5	36.3	30.4	60.0	50.0	23.7	19.6	L	
14.73868	22.2	16.1	14.5	36.7	30.6	60.0	50.0	23.3	19.4	N	
17.33592	21.6	16.4	14.7	36.3	31.1	60.0	50.0	23.7	18.9	N	
17.35651	21.1	15.9	14.7	35.8	30.6	60.0	50.0	24.2	19.4	L	

Conducted Emission

Test place : Ise EMC Lab. No.2 Semi Anechoic Chamber
Report No. : 11397594H
Date : December 22, 2016
Temperature / Humidity : 20 deg. C / 45 % RH
Engineer : Ryota Yamanaka
Mode : Circular Polarized Antenna without cable

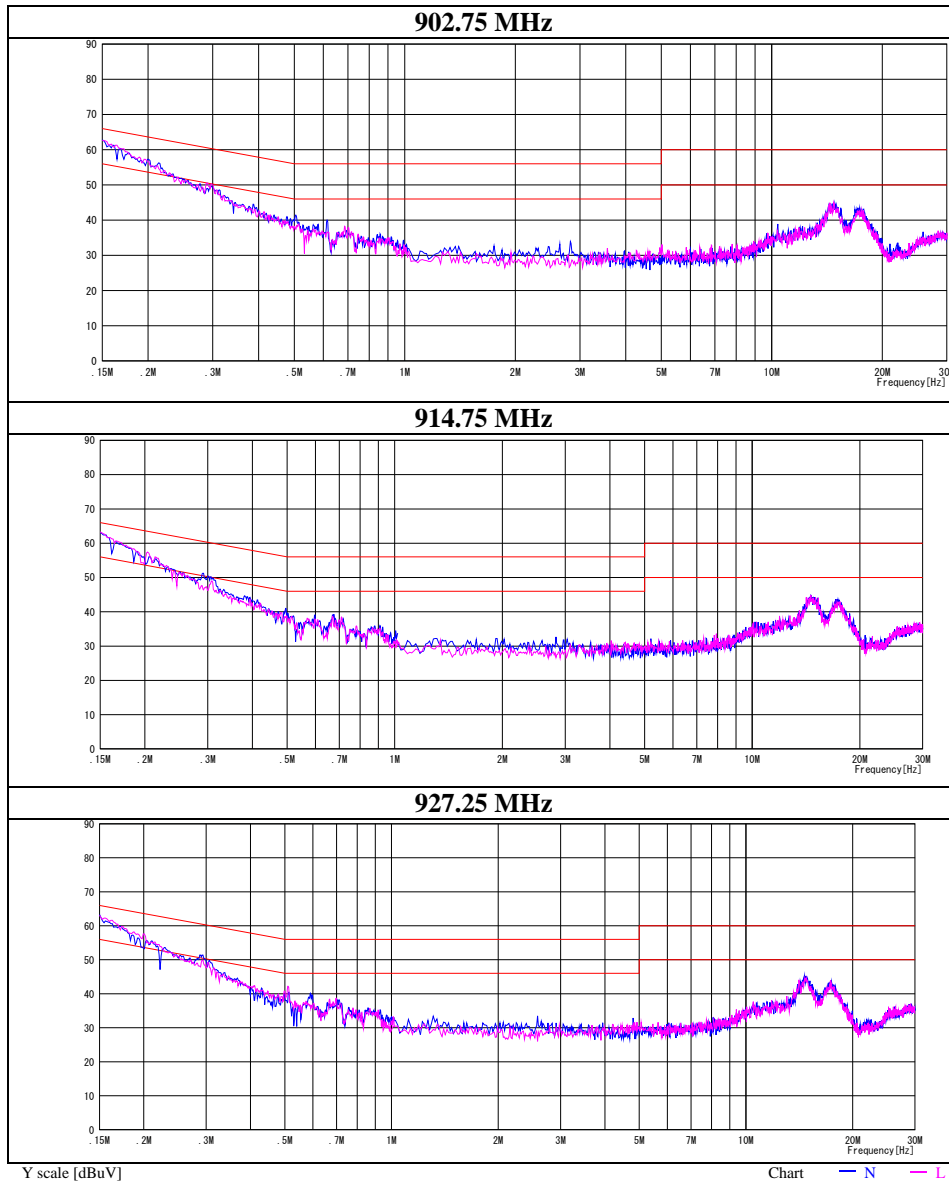

UL Japan, Inc.

Ise EMC Lab.

4383-326 Asama-cho, Ise-shi, Mie-ken 516-0021 JAPAN

Telephone : +81 596 24 8999

Facsimile : +81 596 24 8124

Conducted Emission Cable Antenna (1m)

DATA OF CONDUCTED EMISSION TEST

UL Japan, Inc. Ise EMC Lab. No.2 Semi Anechoic Chamber
Date : 2016/12/22

Report No. : 11397594H
Temp./Humi. : 20deg. C / 45% RH
Engineer : Ryota Yamanaka

Mode / Remarks : Tx_Lch_Cable 1m Ant

LIMIT : FCC15.107(a) QP ClassB
FCC15.107(a) AV ClassB

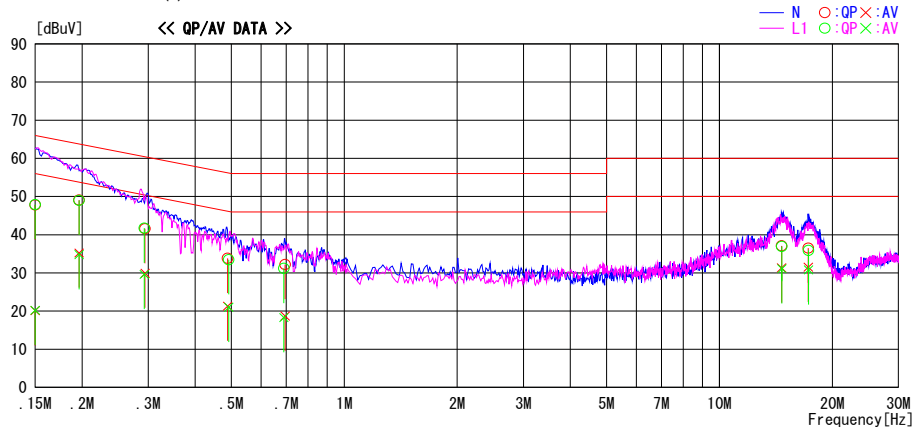

Frequency [MHz]	Reading Level		Corr. Factor [dB]	Results		Limit		Margin		Phase	Comment
	QP [dBuV]	AV [dBuV]		QP [dBuV]	AV [dBuV]	QP [dBuV]	AV [dBuV]	QP [dB]	AV [dB]		
0.15000	34.6	6.9	13.2	47.8	20.1	66.0	56.0	18.2	35.9	N	
0.15000	34.7	7.0	13.2	47.9	20.2	66.0	56.0	18.1	35.8	L	
0.19640	35.8	21.6	13.2	49.0	34.8	63.8	53.8	14.8	19.0	L	
0.19650	35.9	22.0	13.2	49.1	35.2	63.8	53.8	14.7	18.6	N	
0.29300	28.5	16.4	13.2	41.7	29.6	60.4	50.4	18.7	20.8	L	
0.29445	28.4	16.7	13.2	41.6	29.9	60.4	50.4	18.8	20.5	N	
0.48854	20.6	8.1	13.2	33.8	21.3	56.2	46.2	22.4	24.9	N	
0.49182	20.3	7.8	13.2	33.5	21.0	56.1	46.1	22.6	25.1	L	
0.69056	17.9	5.0	13.3	31.2	18.3	56.0	46.0	24.8	27.7	L	
0.69542	18.9	5.4	13.3	32.2	18.7	56.0	46.0	23.8	27.3	N	
14.64300	22.6	16.8	14.5	37.1	31.3	60.0	50.0	22.9	18.7	N	
14.66276	22.4	16.6	14.5	36.9	31.1	60.0	50.0	23.1	18.9	L	
17.24594	21.8	16.8	14.7	36.5	31.5	60.0	50.0	23.5	18.5	N	
17.26552	21.2	16.1	14.7	35.9	30.8	60.0	50.0	24.1	19.2	L	

CHART : WITH FACTOR. Peak hold data. CALCULATION : RESULT = READING + C.F (LISN + ATTEN + CABLE)
Except for the above table : adequate margin data below the limits.

Conducted Emission

Test place Ise EMC Lab. No.2 Semi Anechoic Chamber
Report No. 11397594H
Date December 22, 2016
Temperature / Humidity 20 deg. C / 45 % RH
Engineer Ryota Yamanaka
Mode Cable Antenna (1m)

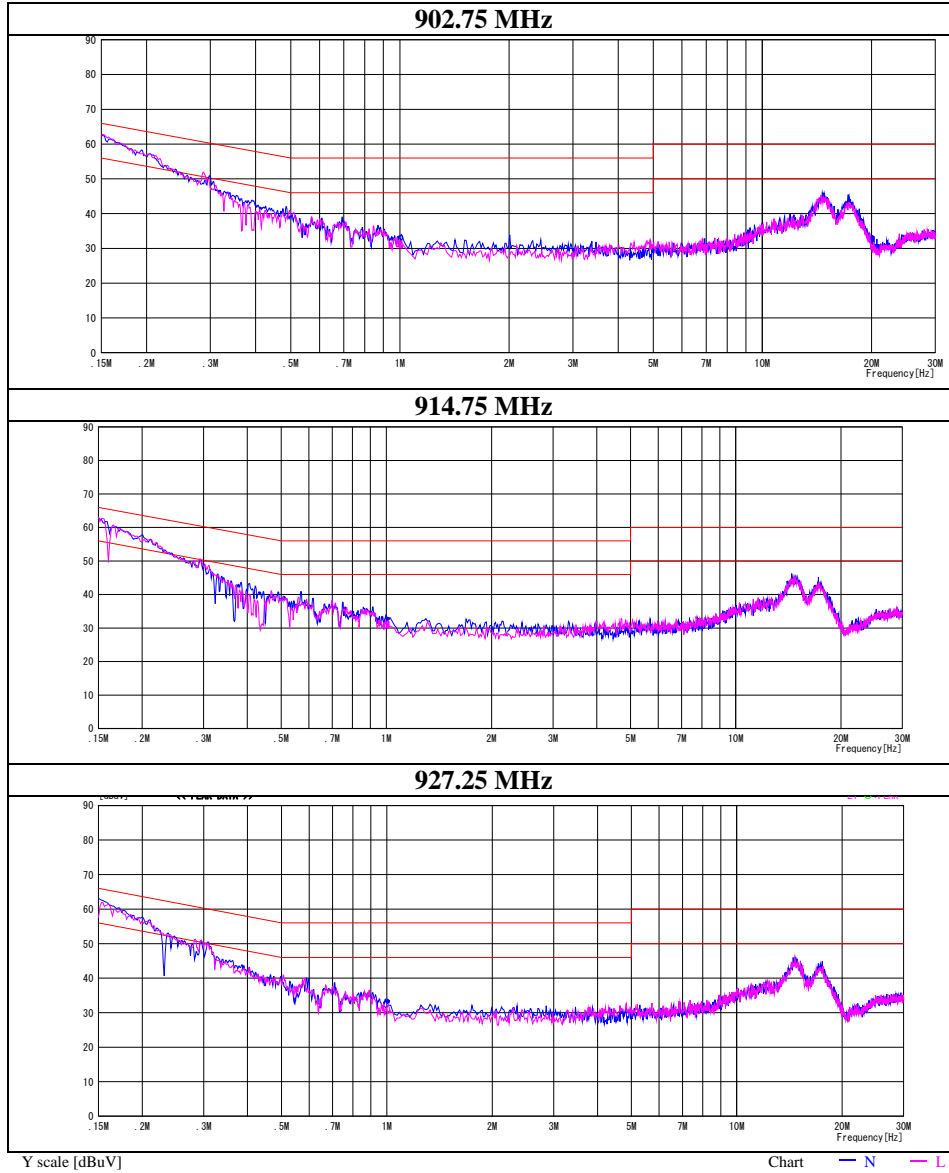

20dB Bandwidth and Carrier Frequency Separation

Test place Ise EMC Lab. No.2 Measurement Room
Report No. 11397594H
Date December 22, 2016
Temperature / Humidity 20 deg. C / 45 % RH
Engineer Ryota Yamanaka
Mode Tx, Hopping Off / On

[20 dB Bandwidth]

Freq. [MHz]	20dB Bandwidth [MHz]	Limit for 20dB Bandwidth [MHz]
902.75	0.145	0.500
914.75	0.191	0.500
927.25	0.144	0.500

[Carrier Frequency Separation]

Freq. [MHz]	Carrier Frequency Separation [MHz]	Limit for Carrier Frequency separation [MHz]
902.75	0.500	≥ 0.145
914.75	0.500	≥ 0.191
927.25	0.500	≥ 0.144

Limit: 20dB Bandwidth or 25kHz (whichever is greater).

20dB Bandwidth and Carrier Frequency Separation

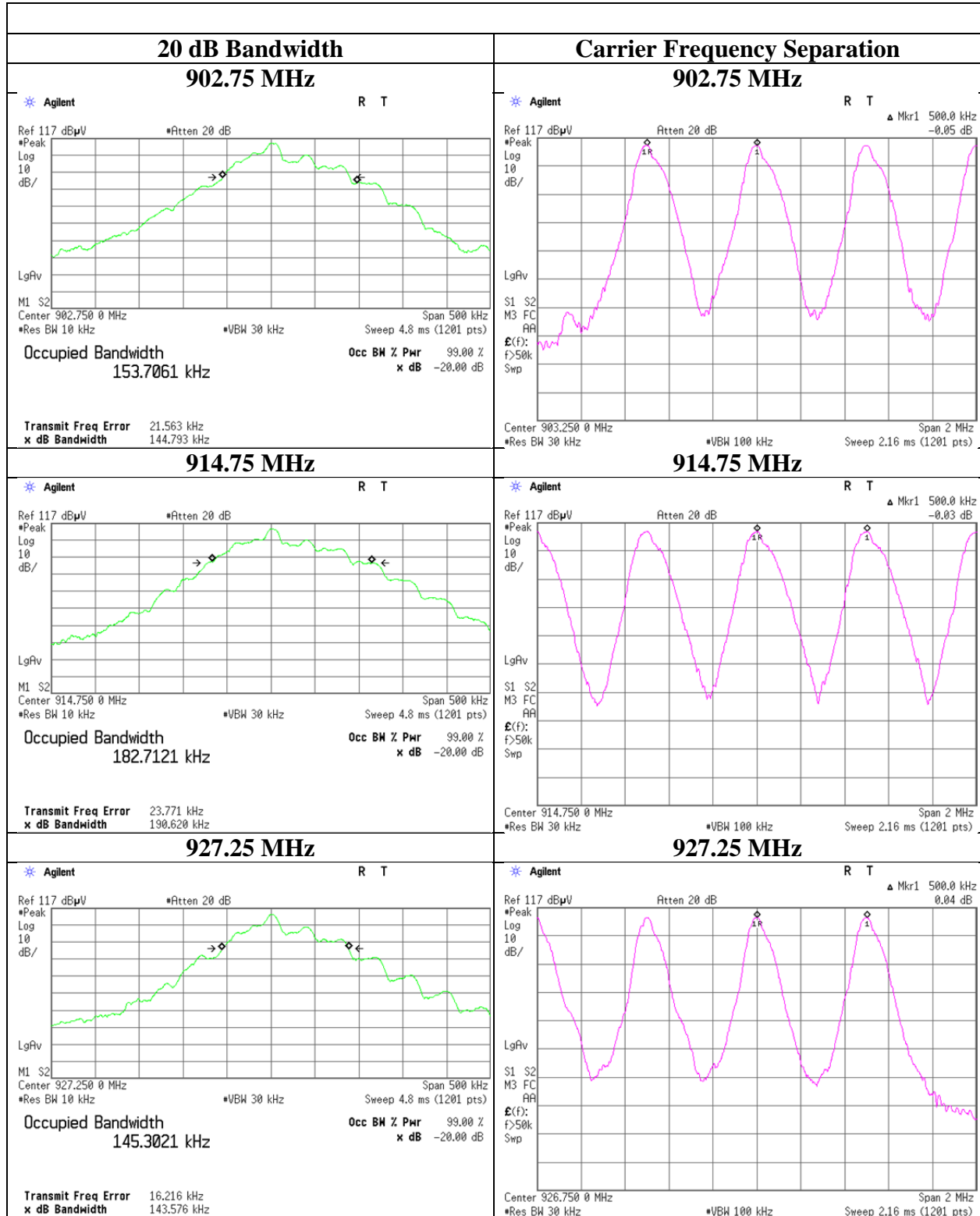

UL Japan, Inc.

Ise EMC Lab.

4383-326 Asama-cho, Ise-shi, Mie-ken 516-0021 JAPAN

Telephone : +81 596 24 8999

Facsimile : +81 596 24 8124

Number of Hopping Frequency

Test place	Ise EMC Lab. No.11 Measurement Room
Report No.	11397594H
Date	December 25, 2016
Temperature / Humidity	22 deg. C / 40 % RH
Engineer	Shuichi Ohyama
Mode	Tx, Hopping On

Number of channel [channels]	Limit [channels]
50	>= 50

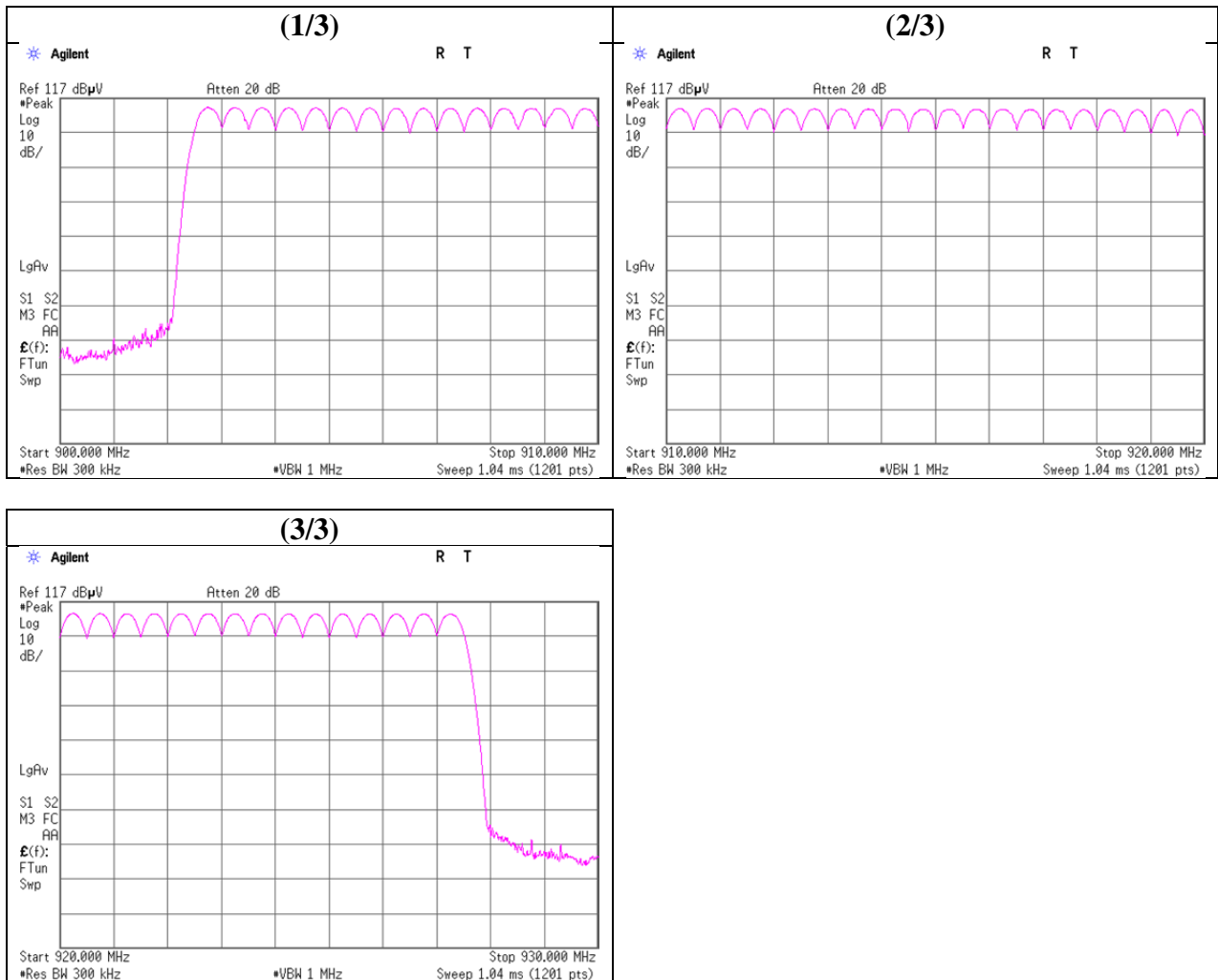

Dwell time

Test place Ise EMC Lab. No.11 Measurement Room
Report No. 11397594H
Date January 6, 2017
Temperature / Humidity 24 deg. C / 41 % RH
Engineer Shuichi Ohyama
Mode Tx, Hopping On

Frequency [MHz]	Number of transmission in 20 sec period	Length of transmission [msec]	Result [msec]	Limit [msec]
902.75	1.0	375.4	375.4	400
914.75	1.0	376.7	376.7	400
927.25	1.0	380.4	380.4	400

Sample Calculation

Result = Number of transmission x Length of transmission

Dwell time

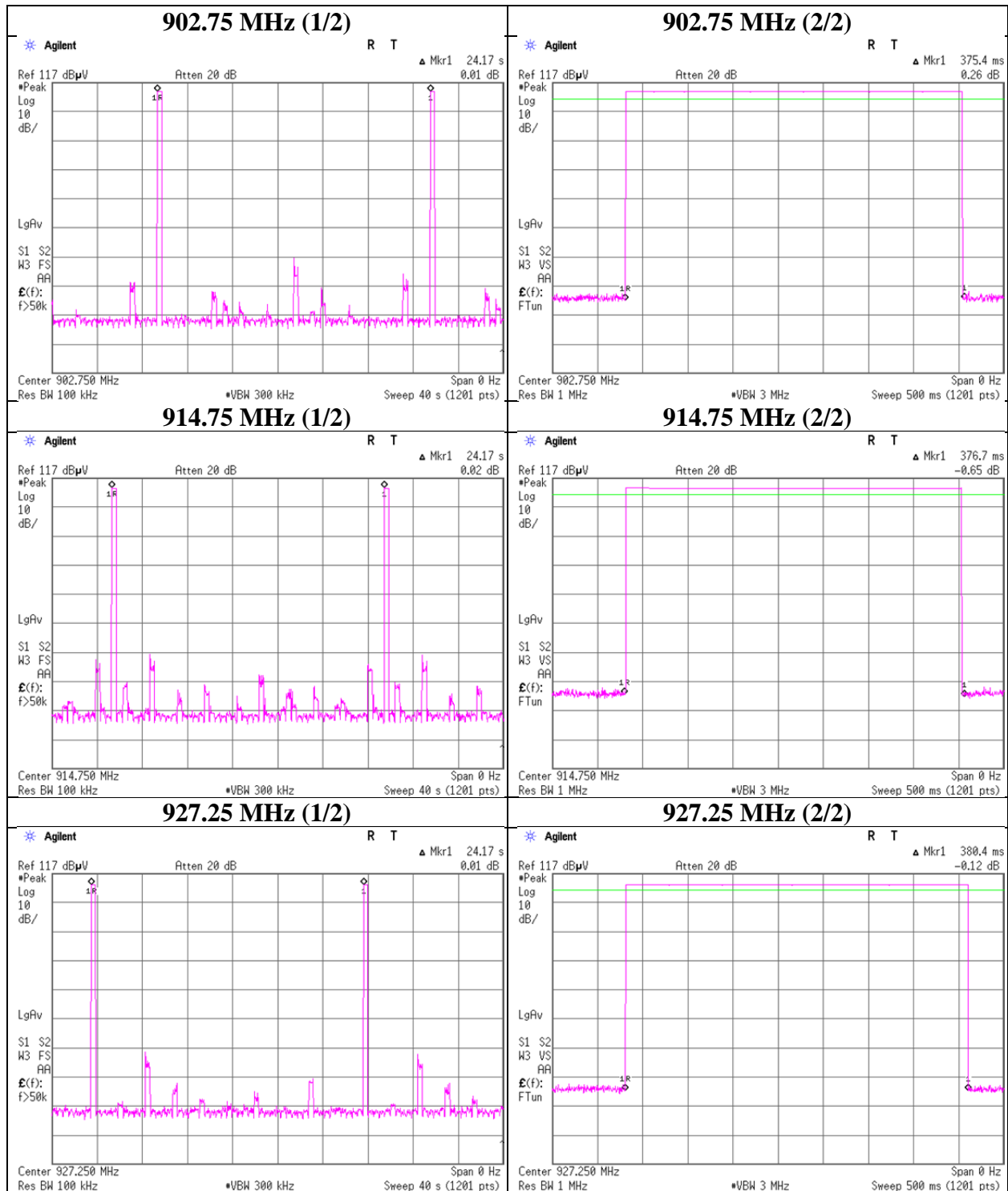

UL Japan, Inc.

Ise EMC Lab.

4383-326 Asama-cho, Ise-shi, Mie-ken 516-0021 JAPAN

Telephone : +81 596 24 8999

Facsimile : +81 596 24 8124

Maximum Peak Output Power

Test place : Ise EMC Lab. No.2 Measurement Room
Report No. : 11397594H
Date : December 22, 2016
Temperature / Humidity : 20 deg. C / 45 % RH
Engineer : Ryota Yamanaka
Mode : Tx, Hopping Off

Freq. [MHz]	Reading [dBm]	Cable Loss [dB]	Atten. Loss [dB]	Result		Limit		Margin [dB]
				[dBm]	[mW]	[dBm]	[mW]	
902.75	5.30	0.00	19.90	25.20	331.13	30.00	1000	4.80
914.75	4.81	0.00	19.89	24.70	295.12	30.00	1000	5.30
927.25	4.31	0.00	19.89	24.20	263.03	30.00	1000	5.80

Sample Calculation:

Result = Reading + Cable Loss + Attenuator Loss

*The equipment and cables were not used for factor 0 dB of the data sheets.

Average Output Power
(Reference data for RF Exposure / SAR testing)

Test place : Ise EMC Lab. No.2 Measurement Room
Report No. : 11397594H
Date : December 22, 2016
Temperature / Humidity : 20 deg. C / 45 % RH
Engineer : Ryota Yamanaka
Mode : Tx, Hopping Off

Freq. [MHz]	Reading [dBm]	Cable Loss [dB]	Atten. Loss [dB]	Result (Time average)		Duty factor [dB]	Result (Burst power average)	
				[dBm]	[mW]		[dBm]	[mW]
902.75	3.35	0.00	19.90	23.25	211.35	0.95	24.20	263.03
914.75	2.91	0.00	19.89	22.80	190.55	0.95	23.75	237.14
927.25	2.41	0.00	19.89	22.30	169.82	0.95	23.25	211.35

Sample Calculation:

Result (Time average) = Reading + Cable Loss + Attenuator Loss

Result (Burst power average) = Time average + Duty factor

*The equipment and cables were not used for factor 0 dB of the data sheets.

Burst Rate Confirmation

Test place	Ise EMC Lab. No.11 Measurement Room
Report No.	11397594H
Date	December 25, 2016
Temperature / Humidity	22 deg. C / 40 % RH
Engineer	Shuichi Ohyama
Mode	Tx, Hopping Off

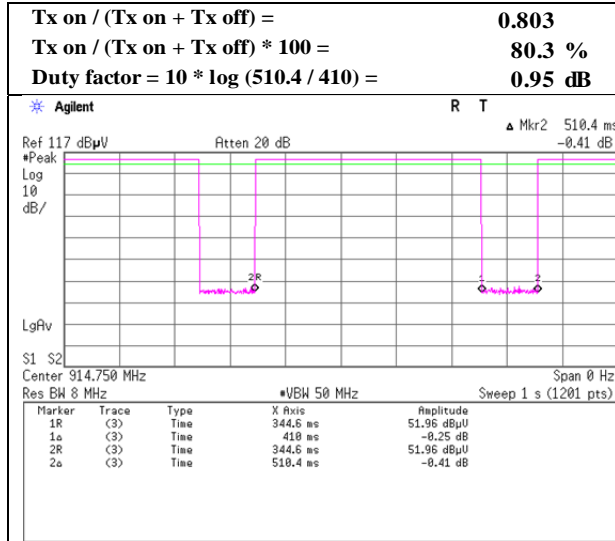

Radiated Spurious Emission
Near field Loop Antenna without cable

Test place Ise EMC Lab. No.2 Semi Anechoic Chamber
Report No. 11397594H
Date December 19, 2016 December 21, 2016
Temperature / Humidity 24 deg. C / 43 % RH 25deg. C / 31% RH
Engineer Hiroyuki Furutaka Hiroyuki Furutaka
Above 1 GHz Below 1 GHz
Mode Tx, Hopping Off, 902.75 MHz

Polarity	Frequency [MHz]	Detector	Reading [dBuV]	Ant.Fac. [dB/m]	Loss [dB]	Gain [dB]	Result [dBuV/m]	Limit [dBuV/m]	Margin [dB]	Remark
Hori	46.000	QP	23.0	12.1	16.8	28.1	23.8	40.0	16.2	
Hori	89.700	QP	25.7	8.2	17.2	28.0	23.1	43.5	20.4	
Hori	134.000	QP	22.7	13.9	17.6	27.8	26.4	43.5	17.1	
Hori	292.300	QP	21.3	13.3	18.6	27.2	26.0	46.0	20.0	
Hori	417.598	QP	22.3	16.0	19.4	27.8	29.9	46.0	16.1	
Hori	563.780	QP	22.4	18.4	19.9	28.0	32.7	46.0	13.3	
Hori	1805.500	PK	48.6	26.6	4.9	35.2	44.9	73.9	29.0	
Hori	2708.250	PK	46.5	28.0	5.1	34.5	45.1	73.9	28.8	
Hori	3611.000	PK	50.6	28.8	5.4	34.0	50.8	73.9	23.1	
Hori	4513.750	PK	44.7	30.6	5.8	34.0	47.1	73.9	26.8	
Hori	5416.500	PK	45.3	32.0	6.4	33.9	49.8	73.9	24.1	
Hori	6319.250	PK	43.9	33.9	6.9	34.1	50.6	73.9	23.3	Floor noise
Hori	7222.000	PK	44.6	36.1	7.1	34.1	53.7	73.9	20.2	Floor noise
Hori	8124.750	PK	43.3	36.9	7.2	34.3	53.1	73.9	20.8	Floor noise
Hori	9027.500	PK	44.2	37.5	7.5	34.6	54.6	73.9	19.3	Floor noise
Hori	1805.500	AV	36.8	26.6	4.9	35.2	33.1	53.9	20.8	
Hori	2708.250	AV	37.3	28.0	5.1	34.5	35.9	53.9	18.0	
Hori	3611.000	AV	45.4	28.8	5.4	34.0	45.6	53.9	8.3	
Hori	4513.750	AV	36.0	30.6	5.8	34.0	38.4	53.9	15.5	
Hori	5416.500	AV	36.3	32.0	6.4	33.9	40.8	53.9	13.1	
Hori	6319.250	AV	31.1	33.9	6.9	34.1	37.8	53.9	16.1	Floor noise
Hori	7222.000	AV	31.3	36.1	7.1	34.1	40.4	53.9	13.5	Floor noise
Hori	8124.750	AV	31.3	36.9	7.2	34.3	41.1	53.9	12.8	Floor noise
Hori	9027.500	AV	31.8	37.5	7.5	34.6	42.2	53.9	11.7	Floor noise
Vert	52.660	QP	28.4	9.9	16.9	28.1	27.1	40.0	12.9	
Vert	88.480	QP	27.4	8.0	17.2	28.0	24.6	43.5	18.9	
Vert	169.000	QP	24.6	15.7	17.8	27.6	30.5	43.5	13.0	
Vert	304.487	QP	22.0	13.6	18.7	27.2	27.1	46.0	18.9	
Vert	496.000	QP	22.4	17.4	19.6	28.1	31.3	46.0	14.7	
Vert	725.000	QP	22.0	20.0	20.5	27.5	35.0	46.0	11.0	
Vert	1805.500	PK	46.4	26.6	4.9	35.2	42.7	73.9	31.2	
Vert	2708.250	PK	46.4	28.0	5.1	34.5	45.0	73.9	28.9	
Vert	3611.000	PK	49.4	28.8	5.4	34.0	49.6	73.9	24.3	
Vert	4513.750	PK	44.8	30.6	5.8	34.0	47.2	73.9	26.7	
Vert	5416.500	PK	45.7	32.0	6.4	33.9	50.2	73.9	23.7	
Vert	6319.250	PK	44.1	33.9	6.9	34.1	50.8	73.9	23.1	Floor noise
Vert	7222.000	PK	43.6	36.1	7.1	34.1	52.7	73.9	21.2	Floor noise
Vert	8124.750	PK	43.6	36.9	7.2	34.3	53.4	73.9	20.5	Floor noise
Vert	9027.500	PK	43.8	37.5	7.5	34.6	54.2	73.9	19.7	Floor noise
Vert	1805.500	AV	37.1	26.6	4.9	35.2	33.4	53.9	20.5	
Vert	2708.250	AV	36.1	28.0	5.1	34.5	34.7	53.9	19.2	
Vert	3611.000	AV	43.8	28.8	5.4	34.0	44.0	53.9	9.9	
Vert	4513.750	AV	35.1	30.6	5.8	34.0	37.5	53.9	16.4	
Vert	5416.500	AV	37.1	32.0	6.4	33.9	41.6	53.9	12.3	
Vert	6319.250	AV	31.2	33.9	6.9	34.1	37.9	53.9	16.0	Floor noise
Vert	7222.000	AV	31.3	36.1	7.1	34.1	40.4	53.9	13.5	Floor noise
Vert	8124.750	AV	31.3	36.9	7.2	34.3	41.1	53.9	12.8	Floor noise
Vert	9027.500	AV	31.8	37.5	7.5	34.6	42.2	53.9	11.7	Floor noise

Result = Reading + Ant Factor + Loss (Cable+Attenuator+Filter+Distance factor(above 1 GHz)) - Gain(Amplifier)

*Other frequency noises omitted in this report were not seen or had enough margin (more than 20 dB).

Distance factor: 1 GHz - 10 GHz $20\log(3.75\text{ m} / 3.0\text{ m}) = 1.94\text{ dB}$

***These results have sufficient margin without taking account Dwell time factor.**

UL Japan, Inc.

Ise EMC Lab.

4383-326 Asama-cho, Ise-shi, Mie-ken 516-0021 JAPAN

Telephone : +81 596 24 8999

Facsimile : +81 596 24 8124

20dBc Data Sheet

Polarity	Frequency [MHz]	Detector	Reading [dBuV]	Ant Factor [dB/m]	Loss [dB]	Gain [dB]	Result [dBuV/m]	Limit [dBuV/m]	Margin [dB]	Remark
Hori	902.750	PK	78.0	21.9	11.2	0.0	111.1	-	-	Carrier
Hori	902.000	PK	25.7	21.9	11.2	0.0	58.8	91.1	32.3	
Vert	902.750	PK	77.9	21.9	11.2	0.0	111.0	-	-	Carrier
Vert	902.000	PK	27.8	21.9	11.2	0.0	60.9	91.0	30.1	

Result = Reading + Ant Factor + Loss (Cable+Attenuator+Filter+Distance factor(above 1 GHz)) - Gain(Amplifier)

Radiated Spurious Emission
(Reference Plot for band-edge)
Near field Loop Antenna without cable

Test place	Ise EMC Lab. No.2 Semi Anechoic Chamber
Report No.	11397594H
Date	December 21, 2016
Temperature / Humidity	25deg. C / 31% RH
Engineer	Hiroyuki Furutaka
	Below 1 GHz
Mode	Tx, Hopping Off, 902.75 MHz

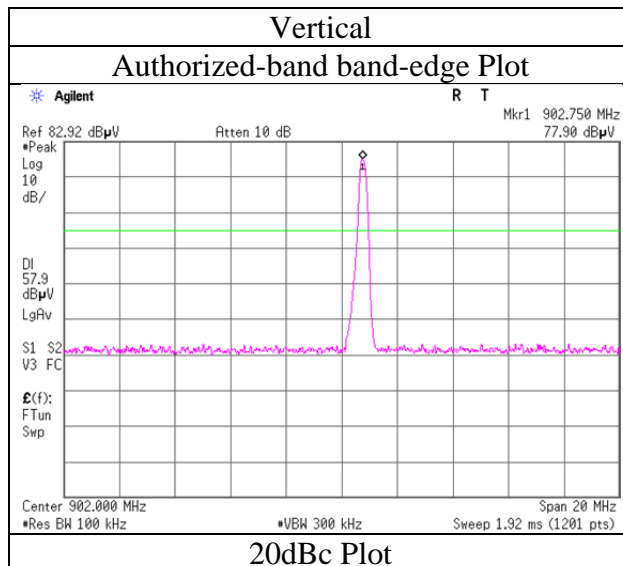
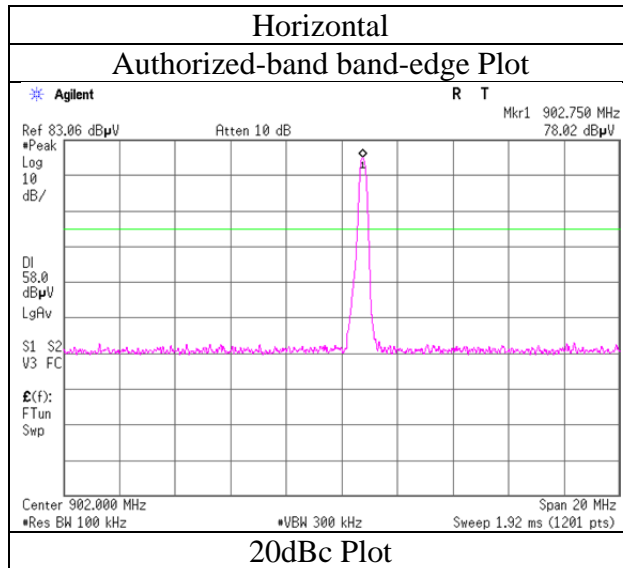

* Final result of restricted band edge was shown in tabular data.

Radiated Spurious Emission
Near field Loop Antenna without cable

Test place Ise EMC Lab. No.2 Semi Anechoic Chamber
Report No. 11397594H
Date December 19, 2016 December 21, 2016
Temperature / Humidity 24 deg. C / 43 % RH 25deg. C / 31% RH
Engineer Hiroyuki Furutaka Hiroyuki Furutaka
Above 1 GHz Below 1 GHz
Mode Tx, Hopping Off, 914.75 MHz

Polarity	Frequency [MHz]	Detector	Reading [dBuV]	Ant.Fac. [dB/m]	Loss [dB]	Gain [dB]	Result [dBuV/m]	Limit [dBuV/m]	Margin [dB]	Remark
Hori	46.200	QP	23.4	12.0	16.8	28.1	24.1	40.0	15.9	
Hori	89.680	QP	25.5	8.2	17.2	28.0	22.9	43.5	20.6	
Hori	134.210	QP	23.0	13.9	17.6	27.8	26.7	43.5	16.8	
Hori	291.000	QP	21.4	13.3	18.6	27.1	26.2	46.0	19.8	
Hori	418.000	QP	22.5	16.0	19.4	27.9	30.0	46.0	16.0	
Hori	567.000	QP	22.4	18.4	19.9	28.0	32.7	46.0	13.3	
Hori	1829.500	PK	47.9	26.7	4.9	35.2	44.3	73.9	29.6	
Hori	2744.250	PK	44.8	28.0	5.1	34.5	43.4	73.9	30.5	
Hori	3659.000	PK	48.7	28.9	5.5	33.9	49.2	73.9	24.7	
Hori	4573.750	PK	45.8	30.8	6.0	34.0	48.6	73.9	25.3	
Hori	5488.500	PK	45.5	32.0	6.4	33.9	50.0	73.9	23.9	
Hori	6403.250	PK	42.7	34.2	6.9	34.1	49.7	73.9	24.2	Floor noise
Hori	7318.000	PK	43.4	36.3	7.2	34.1	52.8	73.9	21.1	Floor noise
Hori	8232.750	PK	44.2	36.8	7.2	34.4	53.8	73.9	20.1	Floor noise
Hori	9147.500	PK	44.1	37.7	7.5	34.7	54.6	73.9	19.3	Floor noise
Hori	1829.500	AV	37.1	26.7	4.9	35.2	33.5	53.9	20.4	
Hori	2744.250	AV	33.6	28.0	5.1	34.5	32.2	53.9	21.7	
Hori	3659.000	AV	42.4	28.9	5.5	33.9	42.9	53.9	11.0	
Hori	4573.750	AV	38.0	30.8	6.0	34.0	40.8	53.9	13.1	
Hori	5488.500	AV	37.4	32.0	6.4	33.9	41.9	53.9	12.0	
Hori	6403.250	AV	30.5	34.2	6.9	34.1	37.5	53.9	16.4	Floor noise
Hori	7318.000	AV	31.0	36.3	7.2	34.1	40.4	53.9	13.5	Floor noise
Hori	8232.750	AV	30.9	36.8	7.2	34.4	40.5	53.9	13.4	Floor noise
Hori	9147.500	AV	31.4	37.7	7.5	34.7	41.9	53.9	12.0	Floor noise
Vert	52.780	QP	28.1	9.8	16.9	28.1	26.7	40.0	13.3	
Vert	88.560	QP	27.6	8.1	17.2	28.0	24.9	43.5	18.6	
Vert	169.000	QP	25.0	15.7	17.8	27.6	30.9	43.5	12.6	
Vert	304.500	QP	22.4	13.6	18.7	27.2	27.5	46.0	18.5	
Vert	498.760	QP	22.5	17.5	19.6	28.1	31.5	46.0	14.5	
Vert	724.340	QP	22.5	20.0	20.5	27.5	35.5	46.0	10.5	
Vert	1829.500	PK	49.1	26.7	4.9	35.2	45.5	73.9	28.4	
Vert	2744.250	PK	45.2	28.0	5.1	34.5	43.8	73.9	30.1	
Vert	3659.000	PK	48.4	28.9	5.5	33.9	48.9	73.9	25.0	
Vert	4573.750	PK	45.3	30.8	6.0	34.0	48.1	73.9	25.8	
Vert	5488.500	PK	45.8	32.0	6.4	33.9	50.3	73.9	23.6	
Vert	6403.250	PK	30.7	34.2	6.9	34.1	37.7	73.9	36.2	Floor noise
Vert	7318.000	PK	43.4	36.3	7.2	34.1	52.8	73.9	21.1	Floor noise
Vert	8232.750	PK	43.9	36.8	7.2	34.4	53.5	73.9	20.4	Floor noise
Vert	9147.500	PK	44.5	37.7	7.5	34.7	55.0	73.9	18.9	Floor noise
Vert	1829.500	AV	42.4	26.7	4.9	35.2	38.8	53.9	15.1	
Vert	2744.250	AV	33.7	28.0	5.1	34.5	32.3	53.9	21.6	
Vert	3659.000	AV	43.6	28.9	5.5	33.9	44.1	53.9	9.8	
Vert	4573.750	AV	36.1	30.8	6.0	34.0	38.9	53.9	15.0	
Vert	5488.500	AV	37.2	32.0	6.4	33.9	41.7	53.9	12.2	
Vert	6403.250	AV	34.0	34.2	6.9	34.1	41.0	53.9	12.9	Floor noise
Vert	7318.000	AV	30.9	36.3	7.2	34.1	40.3	53.9	13.6	Floor noise
Vert	8232.750	AV	30.8	36.8	7.2	34.4	40.4	53.9	13.5	Floor noise
Vert	9147.500	AV	31.4	37.7	7.5	34.7	41.9	53.9	12.0	Floor noise

Result = Reading + Ant Factor + Loss (Cable+Attenuator+Filter+Distance factor(above 1 GHz)) - Gain(Amplifier)

*Other frequency noises omitted in this report were not seen or had enough margin (more than 20 dB).

Distance factor: 1 GHz - 10 GHz $20\log(3.75\text{ m} / 3.0\text{ m}) = 1.94\text{ dB}$

***These results have sufficient margin without taking account Dwell time factor.**

UL Japan, Inc.

Ise EMC Lab.

4383-326 Asama-cho, Ise-shi, Mie-ken 516-0021 JAPAN

Telephone : +81 596 24 8999

Facsimile : +81 596 24 8124

Radiated Spurious Emission
Near field Loop Antenna without cable

Test place Ise EMC Lab. No.2 Semi Anechoic Chamber
Report No. 11397594H
Date December 19, 2016 December 21, 2016
Temperature / Humidity 24 deg. C / 43 % RH 25deg. C / 31% RH
Engineer Hiroyuki Furutaka Hiroyuki Furutaka
Above 1 GHz Below 1 GHz
Mode Tx, Hopping Off, 927.25 MHz

Polarity	Frequency [MHz]	Detector	Reading [dBuV]	Ant.Fac. [dB/m]	Loss [dB]	Gain [dB]	Result [dBuV/m]	Limit [dBuV/m]	Margin [dB]	Remark
Hori	45.000	QP	23.5	12.5	16.8	28.1	24.7	40.0	15.3	
Hori	89.231	QP	25.5	8.2	17.2	28.0	22.9	43.5	20.6	
Hori	134.200	QP	23.1	13.9	17.6	27.8	26.8	43.5	16.7	
Hori	290.345	QP	21.3	13.3	18.6	27.1	26.1	46.0	19.9	
Hori	417.653	QP	22.4	16.0	19.4	27.8	30.0	46.0	16.0	
Hori	566.324	QP	22.2	18.4	19.9	28.0	32.5	46.0	13.5	
Hori	1854.500	PK	47.9	26.7	4.9	35.2	44.3	73.9	29.6	
Hori	2781.750	PK	48.1	28.1	5.2	34.5	46.9	73.9	27.0	
Hori	3709.000	PK	51.4	29.1	5.5	33.9	52.1	73.9	21.8	
Hori	4636.250	PK	46.0	31.0	6.0	34.0	49.0	73.9	24.9	
Hori	5563.500	PK	45.1	32.1	6.4	33.9	49.7	73.9	24.2	
Hori	6490.750	PK	43.1	34.5	7.0	34.1	50.5	73.9	23.4	Floor noise
Hori	7418.000	PK	42.9	36.4	7.2	34.1	52.4	73.9	21.5	Floor noise
Hori	8345.250	PK	44.0	36.7	7.3	34.4	53.6	73.9	20.3	Floor noise
Hori	9272.500	PK	43.9	38.0	7.6	34.7	54.8	73.9	19.1	Floor noise
Hori	1854.500	AV	35.2	26.7	4.9	35.2	31.6	53.9	22.3	
Hori	2781.750	AV	33.1	28.1	5.2	34.5	31.9	53.9	22.0	
Hori	3709.000	AV	35.8	29.1	5.5	33.9	36.5	53.9	17.4	
Hori	4636.250	AV	31.2	31.0	6.0	34.0	34.2	53.9	19.7	
Hori	5563.500	AV	31.1	32.1	6.4	33.9	35.7	53.9	18.2	
Hori	6490.750	AV	30.6	34.5	7.0	34.1	38.0	53.9	15.9	Floor noise
Hori	7418.000	AV	30.5	36.4	7.2	34.1	40.0	53.9	13.9	Floor noise
Hori	8345.250	AV	31.0	36.7	7.3	34.4	40.6	53.9	13.3	Floor noise
Hori	9272.500	AV	31.6	38.0	7.6	34.7	42.5	53.9	11.4	Floor noise
Vert	52.800	QP	28.0	9.8	16.9	28.1	26.6	40.0	13.4	
Vert	88.650	QP	27.2	8.1	17.2	28.0	24.5	43.5	19.0	
Vert	169.012	QP	25.1	15.7	17.8	27.6	31.0	43.5	12.5	
Vert	304.213	QP	22.5	13.6	18.7	27.2	27.6	46.0	18.4	
Vert	498.760	QP	22.7	17.5	19.6	28.1	31.7	46.0	14.3	
Vert	724.340	QP	22.8	20.0	20.5	27.5	35.8	46.0	10.2	
Vert	1854.500	PK	48.9	26.7	4.9	35.2	45.3	73.9	28.6	
Vert	2781.750	PK	47.4	28.1	5.2	34.5	46.2	73.9	27.7	
Vert	3709.000	PK	51.3	29.1	5.5	33.9	52.0	73.9	21.9	
Vert	4636.250	PK	45.0	31.0	6.0	34.0	48.0	73.9	25.9	
Vert	5563.500	PK	46.1	32.1	6.4	33.9	50.7	73.9	23.2	
Vert	6490.750	PK	43.0	34.5	7.0	34.1	50.4	73.9	23.5	Floor noise
Vert	7418.000	PK	43.2	36.4	7.2	34.1	52.7	73.9	21.2	Floor noise
Vert	8345.250	PK	43.1	36.7	7.3	34.4	52.7	73.9	21.2	Floor noise
Vert	9272.500	PK	44.0	38.0	7.6	34.7	54.9	73.9	19.0	Floor noise
Vert	1854.500	AV	43.0	26.7	4.9	35.2	39.4	53.9	14.5	
Vert	2781.750	AV	38.8	28.1	5.2	34.5	37.6	53.9	16.3	
Vert	3709.000	AV	47.4	29.1	5.5	33.9	48.1	53.9	5.8	
Vert	4636.250	AV	35.7	31.0	6.0	34.0	38.7	53.9	15.2	
Vert	5563.500	AV	38.6	32.1	6.4	33.9	43.2	53.9	10.7	
Vert	6490.750	AV	30.5	34.5	7.0	34.1	37.9	53.9	16.0	Floor noise
Vert	7418.000	AV	30.5	36.4	7.2	34.1	40.0	53.9	13.9	Floor noise
Vert	8345.250	AV	30.9	36.7	7.3	34.4	40.5	53.9	13.4	Floor noise
Vert	9272.500	AV	31.7	38.0	7.6	34.7	42.6	53.9	11.3	Floor noise

Result = Reading + Ant Factor + Loss (Cable+Attenuator+Filter+Distance factor(above 1 GHz)) - Gain(Amplifier)

*Other frequency noises omitted in this report were not seen or had enough margin (more than 20 dB).

Distance factor: 1 GHz - 10 GHz $20\log(3.75\text{ m} / 3.0\text{ m}) = 1.94\text{ dB}$

*These results have sufficient margin without taking account Dwell time factor.

UL Japan, Inc.

Ise EMC Lab.

4383-326 Asama-cho, Ise-shi, Mie-ken 516-0021 JAPAN

Telephone : +81 596 24 8999

Facsimile : +81 596 24 8124

20dBc Data Sheet

Polarity	Frequency [MHz]	Detector	Reading [dBuV]	Ant Factor [dB/m]	Loss [dB]	Gain [dB]	Result [dBuV/m]	Limit [dBuV/m]	Margin [dB]	Remark
Hori	927.250	PK	78.8	22.0	11.3	0.0	112.1	-	-	Carrier
Hori	928.000	PK	25.3	22.0	11.3	0.0	58.6	92.1	33.5	
Vert	927.250	PK	78.5	22.0	11.3	0.0	111.8	-	-	Carrier
Vert	928.000	PK	25.2	22.0	11.3	0.0	58.5	91.8	33.3	

Result = Reading + Ant Factor + Loss (Cable+Attenuator+Filter+Distance factor(above 1 GHz)) - Gain(Amplifier)

Radiated Spurious Emission
(Reference Plot for band-edge)
Near field Loop Antenna without cable

Test place	Ise EMC Lab. No.2 Semi Anechoic Chamber
Report No.	11397594H
Date	December 21, 2016
Temperature / Humidity	25deg. C / 31% RH
Engineer	Hiroyuki Furutaka
	Below 1 GHz
Mode	Tx, Hopping Off, 927.25 MHz

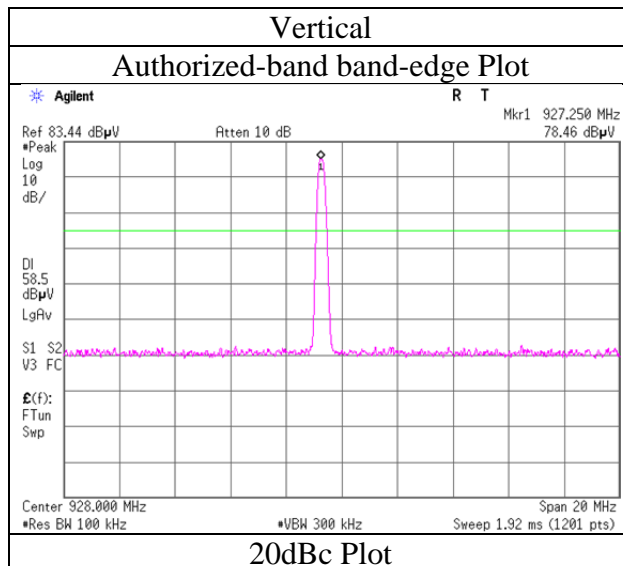
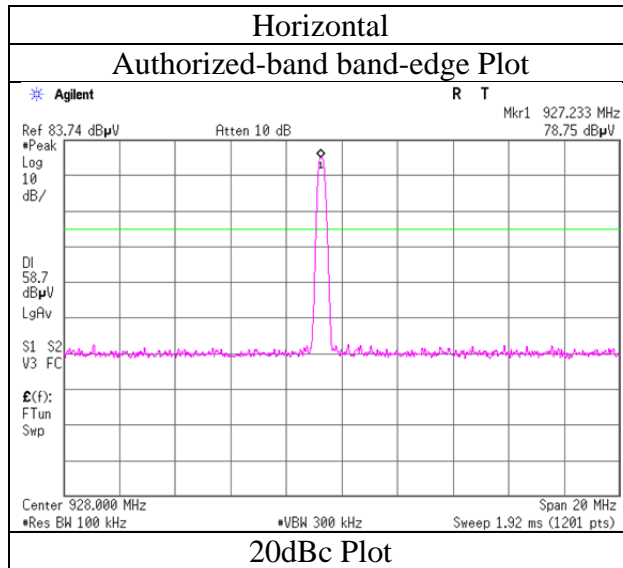

* Final result of restricted band edge was shown in tabular data.

Radiated Spurious Emission
Circular Polarized Antenna without cable

Test place Ise EMC Lab. No.2 Semi Anechoic Chamber
Report No. 11397594H
Date December 19, 2016 December 21, 2016
Temperature / Humidity 24 deg. C / 43 % RH 25deg. C / 31% RH
Engineer Hiroyuki Furutaka Hiroyuki Furutaka
Above 1 GHz Below 1 GHz
Mode Tx, Hopping Off, 902.75 MHz

Polarity	Frequency [MHz]	Detector	Reading [dBuV]	Ant.Fac. [dB/m]	Loss [dB]	Gain [dB]	Result [dBuV/m]	Limit [dBuV/m]	Margin [dB]	Remark
Hori	35.000	QP	24.0	15.9	16.7	28.2	28.4	40.0	11.6	
Hori	93.643	QP	24.8	9.0	17.3	28.0	23.1	43.5	20.4	
Hori	179.100	QP	22.4	16.1	17.9	27.5	28.9	43.5	14.6	
Hori	291.000	QP	21.5	13.3	18.6	27.1	26.3	46.0	19.7	
Hori	1805.500	PK	56.2	26.6	4.9	35.2	52.5	73.9	21.4	
Hori	2708.250	PK	46.2	28.0	5.1	34.5	44.8	73.9	29.1	
Hori	3611.000	PK	47.8	28.8	5.4	34.0	48.0	73.9	25.9	
Hori	4513.750	PK	50.5	30.6	5.8	34.0	52.9	73.9	21.0	
Hori	5416.500	PK	45.9	32.0	6.4	33.9	50.4	73.9	23.5	
Hori	6319.250	PK	44.5	33.9	6.9	34.1	51.2	73.9	22.7	Floor noise
Hori	7222.000	PK	44.2	36.1	7.1	34.1	53.3	73.9	20.6	Floor noise
Hori	8124.750	PK	43.1	36.9	7.2	34.3	52.9	73.9	21.0	Floor noise
Hori	9027.500	PK	44.0	37.5	7.5	34.6	54.4	73.9	19.5	Floor noise
Hori	1805.500	AV	47.1	26.6	4.9	35.2	43.4	53.9	10.5	
Hori	2708.250	AV	37.5	28.0	5.1	34.5	36.1	53.9	17.8	
Hori	3611.000	AV	41.5	28.8	5.4	34.0	41.7	53.9	12.2	
Hori	4513.750	AV	45.6	30.6	5.8	34.0	48.0	53.9	5.9	
Hori	5416.500	AV	38.7	32.0	6.4	33.9	43.2	53.9	10.7	
Hori	6319.250	AV	32.2	33.9	6.9	34.1	38.9	53.9	15.0	Floor noise
Hori	7222.000	AV	31.0	36.1	7.1	34.1	40.1	53.9	13.8	Floor noise
Hori	8124.750	AV	31.0	36.9	7.2	34.3	40.8	53.9	13.1	Floor noise
Hori	9027.500	AV	31.6	37.5	7.5	34.6	42.0	53.9	11.9	Floor noise
Vert	34.282	QP	25.2	16.1	16.7	28.2	29.8	40.0	10.2	
Vert	52.420	QP	31.7	9.9	16.9	28.1	30.4	40.0	9.6	
Vert	144.700	QP	26.7	14.5	17.7	27.8	31.1	43.5	12.4	
Vert	303.123	QP	22.1	13.5	18.7	27.2	27.1	46.0	18.9	
Vert	1805.500	PK	54.7	26.6	4.9	35.2	51.0	73.9	22.9	
Vert	2708.250	PK	44.4	28.0	5.1	34.5	43.0	73.9	30.9	
Vert	3611.000	PK	47.2	28.8	5.4	34.0	47.4	73.9	26.5	
Vert	4513.750	PK	50.0	30.6	5.8	34.0	52.4	73.9	21.5	
Vert	5416.500	PK	45.6	32.0	6.4	33.9	50.1	73.9	23.8	
Vert	6319.250	PK	44.5	33.9	6.9	34.1	51.2	73.9	22.7	Floor noise
Vert	7222.000	PK	43.7	36.1	7.1	34.1	52.8	73.9	21.1	Floor noise
Vert	8124.750	PK	43.7	36.9	7.2	34.3	53.5	73.9	20.4	Floor noise
Vert	9027.500	PK	43.7	37.5	7.5	34.6	54.1	73.9	19.8	Floor noise
Vert	1805.500	AV	44.0	26.6	4.9	35.2	40.3	53.9	13.6	
Vert	2708.250	AV	33.9	28.0	5.1	34.5	32.5	53.9	21.4	
Vert	3611.000	AV	39.7	28.8	5.4	34.0	39.9	53.9	14.0	
Vert	4513.750	AV	45.5	30.6	5.8	34.0	47.9	53.9	6.0	
Vert	5416.500	AV	37.1	32.0	6.4	33.9	41.6	53.9	12.3	
Vert	6319.250	AV	31.7	33.9	6.9	34.1	38.4	53.9	15.5	Floor noise
Vert	7222.000	AV	31.5	36.1	7.1	34.1	40.6	53.9	13.3	Floor noise
Vert	8124.750	AV	31.5	36.9	7.2	34.3	41.3	53.9	12.6	Floor noise
Vert	9027.500	AV	31.7	37.5	7.5	34.6	42.1	53.9	11.8	Floor noise

Result = Reading + Ant Factor + Loss (Cable+Attenuator+Filter+Distance factor(above 1 GHz)) - Gain(Amplifier)

*Other frequency noises omitted in this report were not seen or had enough margin (more than 20 dB).

Distance factor: 1 GHz - 10 GHz $20\log(3.75\text{ m} / 3.0\text{ m}) = 1.94\text{ dB}$

***These results have sufficient margin without taking account Dwell time factor.**

20dBc Data Sheet

Polarity	Frequency [MHz]	Detector	Reading [dBuV]	Ant Factor [dB/m]	Loss [dB]	Gain [dB]	Result [dBuV/m]	Limit [dBuV/m]	Margin [dB]	Remark
Hori	902.750	PK	88.6	21.9	11.2	0.0	121.7	-	-	Carrier
Hori	902.000	PK	28.2	21.9	11.2	0.0	61.3	101.7	40.4	
Hori	941.153	PK	41.9	22.1	21.2	26.6	58.6	101.7	43.1	
Vert	902.750	PK	87.8	21.9	11.2	0.0	120.9	-	-	Carrier
Vert	902.000	PK	27.1	21.9	11.2	0.0	60.2	100.9	40.7	
Vert	941.150	PK	39.5	22.1	21.2	26.6	56.2	100.9	44.7	

Result = Reading + Ant Factor + Loss (Cable+Attenuator+Filter+Distance factor(above 1 GHz)) - Gain(Amplifier)

Distance factor: 1 GHz - 10 GHz $20\log(3.75\text{ m} / 3.0\text{ m}) = 1.94\text{ dB}$

UL Japan, Inc.

Ise EMC Lab.

4383-326 Asama-cho, Ise-shi, Mie-ken 516-0021 JAPAN

Telephone : +81 596 24 8999

Facsimile : +81 596 24 8124

Radiated Spurious Emission
(Reference Plot for band-edge)
Circular Polarized Antenna without cable

Test place	Ise EMC Lab. No.2 Semi Anechoic Chamber
Report No.	11397594H
Date	December 21, 2016
Temperature / Humidity	25deg. C / 31% RH
Engineer	Hiroyuki Furutaka
	Below 1 GHz
Mode	Tx, Hopping Off, 902.75 MHz

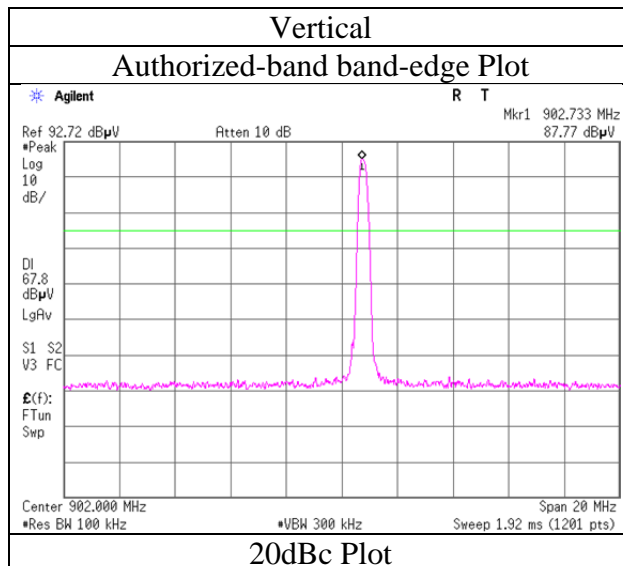
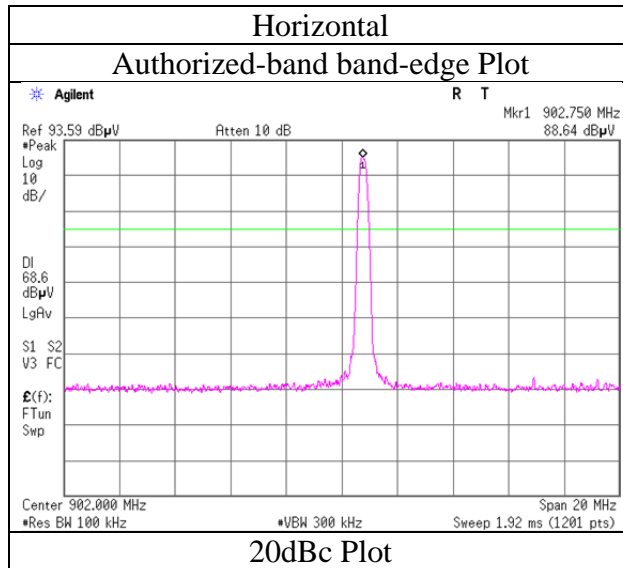

* Final result of restricted band edge was shown in tabular data.

Radiated Spurious Emission
Circular Polarized Antenna without cable

Test place Ise EMC Lab. No.2 Semi Anechoic Chamber
Report No. 11397594H
Date December 19, 2016 December 21, 2016
Temperature / Humidity 24 deg. C / 43 % RH 25deg. C / 31% RH
Engineer Hiroyuki Furutaka Hiroyuki Furutaka
Above 1 GHz Below 1 GHz
Mode Tx, Hopping Off, 914.75 MHz

Polarity	Frequency [MHz]	Detector	Reading [dBuV]	Ant.Fac. [dB/m]	Loss [dB]	Gain [dB]	Result [dBuV/m]	Limit [dBuV/m]	Margin [dB]	Remark
Hori	38.000	QP	23.2	14.8	16.7	28.2	26.5	40.0	13.5	
Hori	95.450	QP	24.3	9.3	17.3	28.0	22.9	43.5	20.6	
Hori	175.000	QP	22.2	15.9	17.9	27.6	28.4	43.5	15.1	
Hori	291.000	QP	21.5	13.3	18.6	27.1	26.3	46.0	19.7	
Hori	1829.500	PK	61.3	26.7	4.9	35.2	57.7	73.9	16.2	
Hori	2744.250	PK	50.6	28.0	5.1	34.5	49.2	73.9	24.7	
Hori	3659.000	PK	48.3	28.9	5.5	33.9	48.8	73.9	25.1	
Hori	4573.750	PK	48.4	30.8	6.0	34.0	51.2	73.9	22.7	
Hori	5488.500	PK	46.3	32.0	6.4	33.9	50.8	73.9	23.1	
Hori	6403.250	PK	44.6	34.2	6.9	34.1	51.6	73.9	22.3	Floor noise
Hori	7318.000	PK	44.0	36.3	7.2	34.1	53.4	73.9	20.5	Floor noise
Hori	8232.750	PK	43.0	36.8	7.2	34.4	52.6	73.9	21.3	Floor noise
Hori	9147.500	PK	43.9	37.7	7.5	34.7	54.4	73.9	19.5	Floor noise
Hori	1829.500	AV	50.7	26.7	4.9	35.2	47.1	53.9	6.8	
Hori	2744.250	AV	41.3	28.0	5.1	34.5	39.9	53.9	14.0	
Hori	3659.000	AV	42.3	28.9	5.5	33.9	42.8	53.9	11.1	
Hori	4573.750	AV	42.7	30.8	6.0	34.0	45.5	53.9	8.4	
Hori	5488.500	AV	38.2	32.0	6.4	33.9	42.7	53.9	11.2	
Hori	6403.250	AV	32.3	34.2	6.9	34.1	39.3	53.9	14.6	Floor noise
Hori	7318.000	AV	30.8	36.3	7.2	34.1	40.2	53.9	13.7	Floor noise
Hori	8232.750	AV	30.9	36.8	7.2	34.4	40.5	53.9	13.4	Floor noise
Hori	9147.500	AV	31.5	37.7	7.5	34.7	42.0	53.9	11.9	Floor noise
Vert	34.000	QP	25.0	16.2	16.7	28.2	29.7	40.0	10.3	
Vert	52.000	QP	31.9	10.1	16.9	28.1	30.8	40.0	9.2	
Vert	143.000	QP	26.8	14.4	17.7	27.8	31.1	43.5	12.4	
Vert	303.123	QP	22.1	13.5	18.7	27.2	27.1	46.0	18.9	
Vert	1829.500	PK	58.6	26.7	4.9	35.2	55.0	73.9	18.9	
Vert	2744.250	PK	49.1	28.0	5.1	34.5	47.7	73.9	26.2	
Vert	3659.000	PK	46.3	28.9	5.5	33.9	46.8	73.9	27.1	
Vert	4573.750	PK	48.3	30.8	6.0	34.0	51.1	73.9	22.8	
Vert	5488.500	PK	45.4	32.0	6.4	33.9	49.9	73.9	24.0	
Vert	6403.250	PK	44.4	34.2	6.9	34.1	51.4	73.9	22.5	Floor noise
Vert	7318.000	PK	43.5	36.3	7.2	34.1	52.9	73.9	21.0	Floor noise
Vert	8232.750	PK	43.7	36.8	7.2	34.4	53.3	73.9	20.6	Floor noise
Vert	9147.500	PK	43.6	37.7	7.5	34.7	54.1	73.9	19.8	Floor noise
Vert	1829.500	AV	50.4	26.7	4.9	35.2	46.8	53.9	7.1	
Vert	2744.250	AV	41.0	28.0	5.1	34.5	39.6	53.9	14.3	
Vert	3659.000	AV	38.2	28.9	5.5	33.9	38.7	53.9	15.2	
Vert	4573.750	AV	42.4	30.8	6.0	34.0	45.2	53.9	8.7	
Vert	5488.500	AV	38.7	32.0	6.4	33.9	43.2	53.9	10.7	
Vert	6403.250	AV	31.6	34.2	6.9	34.1	38.6	53.9	15.3	Floor noise
Vert	7318.000	AV	31.4	36.3	7.2	34.1	40.8	53.9	13.1	Floor noise
Vert	8232.750	AV	31.4	36.8	7.2	34.4	41.0	53.9	12.9	Floor noise
Vert	9147.500	AV	31.6	37.7	7.5	34.7	42.1	53.9	11.8	Floor noise

Result = Reading + Ant Factor + Loss (Cable+Attenuator+Filter+Distance factor(above 1 GHz)) - Gain(Amplifier)

*Other frequency noises omitted in this report were not seen or had enough margin (more than 20 dB).

Distance factor: 1 GHz - 10 GHz $20\log(3.75\text{ m} / 3.0\text{ m}) = 1.94\text{ dB}$

***These results have sufficient margin without taking account Dwell time factor.**

20dBc Data Sheet

Polarity	Frequency [MHz]	Detector	Reading [dBuV]	Ant Factor [dB/m]	Loss [dB]	Gain [dB]	Result [dBuV/m]	Limit [dBuV/m]	Margin [dB]	Remark
Hori	914.750	PK	90.2	21.9	11.3	0.0	123.4	-	-	Carrier
Hori	895.552	PK	33.0	21.8	21.1	26.8	49.1	103.4	54.3	
Hori	933.959	PK	37.3	22.0	21.2	26.6	53.9	103.4	49.5	
Vert	914.750	PK	90.3	21.9	11.3	0.0	123.5	-	-	Carrier
Vert	895.552	PK	32.4	21.8	21.1	26.8	48.5	103.5	55.0	
Vert	933.959	PK	35.8	22.0	21.2	26.6	52.4	103.5	51.1	

Result = Reading + Ant Factor + Loss (Cable+Attenuator+Filter+Distance factor(above 1 GHz)) - Gain(Amplifier)

Distance factor: 1 GHz - 10 GHz $20\log(3.75\text{ m} / 3.0\text{ m}) = 1.94\text{ dB}$

Radiated Spurious Emission
Circular Polarized Antenna without cable

Test place Ise EMC Lab. No.2 Semi Anechoic Chamber
Report No. 11397594H
Date December 19, 2016 December 21, 2016
Temperature / Humidity 24 deg. C / 43 % RH 25deg. C / 31% RH
Engineer Hiroyuki Furutaka Hiroyuki Furutaka
Above 1 GHz Below 1 GHz
Mode Tx, Hopping Off, 927.25 MHz

Polarity	Frequency [MHz]	Detector	Reading [dBuV]	Ant.Fac. [dB/m]	Loss [dB]	Gain [dB]	Result [dBuV/m]	Limit [dBuV/m]	Margin [dB]	Remark
Hori	37.890	QP	23.5	14.8	16.7	28.2	26.8	40.0	13.2	
Hori	95.780	QP	24.6	9.3	17.3	28.0	23.2	43.5	20.3	
Hori	175.000	QP	22.3	15.9	17.9	27.6	28.5	43.5	15.0	
Hori	293.451	QP	21.7	13.4	18.6	27.2	26.5	46.0	19.5	
Hori	1854.500	PK	63.1	26.7	4.9	35.2	59.5	73.9	14.4	
Hori	2781.750	PK	57.0	28.1	5.2	34.5	55.8	73.9	18.1	
Hori	3709.000	PK	52.3	29.1	5.5	33.9	53.0	73.9	20.9	
Hori	4636.250	PK	45.5	31.0	6.0	34.0	48.5	73.9	25.4	
Hori	5563.500	PK	45.8	32.1	6.4	33.9	50.4	73.9	23.5	
Hori	6490.750	PK	44.5	34.5	7.0	34.1	51.9	73.9	22.0	Floor noise
Hori	7418.000	PK	44.0	36.4	7.2	34.1	53.5	73.9	20.4	Floor noise
Hori	8345.250	PK	43.1	36.7	7.3	34.4	52.7	73.9	21.2	Floor noise
Hori	9272.500	PK	43.8	38.0	7.6	34.7	54.7	73.9	19.2	Floor noise
Hori	1854.500	AV	54.6	26.7	4.9	35.2	51.0	53.9	2.9	
Hori	2781.750	AV	47.7	28.1	5.2	34.5	46.5	53.9	7.4	
Hori	3709.000	AV	48.0	29.1	5.5	33.9	48.7	53.9	5.2	
Hori	4636.250	AV	37.3	31.0	6.0	34.0	40.3	53.9	13.6	
Hori	5563.500	AV	37.3	32.1	6.4	33.9	41.9	53.9	12.0	
Hori	6490.750	AV	32.1	34.5	7.0	34.1	39.5	53.9	14.4	Floor noise
Hori	7418.000	AV	30.8	36.4	7.2	34.1	40.3	53.9	13.6	Floor noise
Hori	8345.250	AV	31.0	36.7	7.3	34.4	40.6	53.9	13.3	Floor noise
Hori	9272.500	AV	31.4	38.0	7.6	34.7	42.3	53.9	11.6	Floor noise
Vert	46.780	QP	27.8	11.8	16.8	28.1	28.3	40.0	11.7	
Vert	52.120	QP	31.8	10.0	16.9	28.1	30.6	40.0	9.4	
Vert	147.000	QP	27.0	14.7	17.7	27.8	31.6	43.5	11.9	
Vert	301.000	QP	22.4	13.5	18.7	27.2	27.4	46.0	18.6	
Vert	1854.500	PK	60.8	26.7	4.9	35.2	57.2	73.9	16.7	
Vert	2781.750	PK	50.2	28.1	5.2	34.5	49.0	73.9	24.9	
Vert	3709.000	PK	49.0	29.1	5.5	33.9	49.7	73.9	24.2	
Vert	4636.250	PK	45.8	31.0	6.0	34.0	48.8	73.9	25.1	
Vert	5563.500	PK	46.8	32.1	6.4	33.9	51.4	73.9	22.5	
Vert	6490.750	PK	44.2	34.5	7.0	34.1	51.6	73.9	22.3	Floor noise
Vert	7418.000	PK	43.3	36.4	7.2	34.1	52.8	73.9	21.1	Floor noise
Vert	8345.250	PK	43.5	36.7	7.3	34.4	53.1	73.9	20.8	Floor noise
Vert	9272.500	PK	43.5	38.0	7.6	34.7	54.4	73.9	19.5	Floor noise
Vert	1854.500	AV	51.6	26.7	4.9	35.2	48.0	53.9	5.9	
Vert	2781.750	AV	41.4	28.1	5.2	34.5	40.2	53.9	13.7	
Vert	3709.000	AV	43.3	29.1	5.5	33.9	44.0	53.9	9.9	
Vert	4636.250	AV	38.4	31.0	6.0	34.0	41.4	53.9	12.5	
Vert	5563.500	AV	39.1	32.1	6.4	33.9	43.7	53.9	10.2	
Vert	6490.750	AV	31.5	34.5	7.0	34.1	38.9	53.9	15.0	Floor noise
Vert	7418.000	AV	31.2	36.4	7.2	34.1	40.7	53.9	13.2	Floor noise
Vert	8345.250	AV	31.2	36.7	7.3	34.4	40.8	53.9	13.1	Floor noise
Vert	9272.500	AV	31.5	38.0	7.6	34.7	42.4	53.9	11.5	Floor noise

Result = Reading + Ant Factor + Loss (Cable+Attenuator+Filter+Distance factor(above 1 GHz)) - Gain(Amplifier)

*Other frequency noises omitted in this report were not seen or had enough margin (more than 20 dB).

Distance factor: 1 GHz - 10 GHz $20\log(3.75\text{ m} / 3.0\text{ m}) = 1.94\text{ dB}$

***These results have sufficient margin without taking account Dwell time factor.**

20dBc Data Sheet

Polarity	Frequency [MHz]	Detector	Reading [dBuV]	Ant Factor [dB/m]	Loss [dB]	Gain [dB]	Result [dBuV/m]	Limit [dBuV/m]	Margin [dB]	Remark
Hori	927.250	PK	92.2	22.0	11.3	0.0	125.5	-	-	Carrier
Hori	928.000	PK	31.8	22.0	11.3	0.0	65.1	105.5	40.4	
Vert	927.250	PK	91.8	22.0	11.3	0.0	125.1	-	-	Carrier
Vert	928.000	PK	31.2	22.0	11.3	0.0	64.5	105.1	40.6	

Result = Reading + Ant Factor + Loss (Cable+Attenuator+Filter+Distance factor(above 1 GHz)) - Gain(Amplifier)

Distance factor: 1 GHz - 10 GHz $20\log(3.75\text{ m} / 3.0\text{ m}) = 1.94\text{ dB}$

Radiated Spurious Emission
(Reference Plot for band-edge)
Circular Polarized Antenna without cable

Test place	Ise EMC Lab. No.2 Semi Anechoic Chamber
Report No.	11397594H
Date	December 21, 2016
Temperature / Humidity	25deg. C / 31% RH
Engineer	Hiroyuki Furutaka
	Below 1 GHz
Mode	Tx, Hopping Off, 927.25 MHz

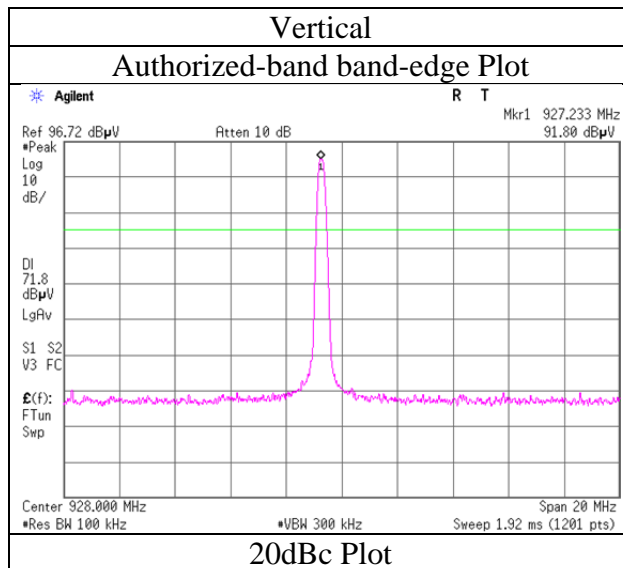
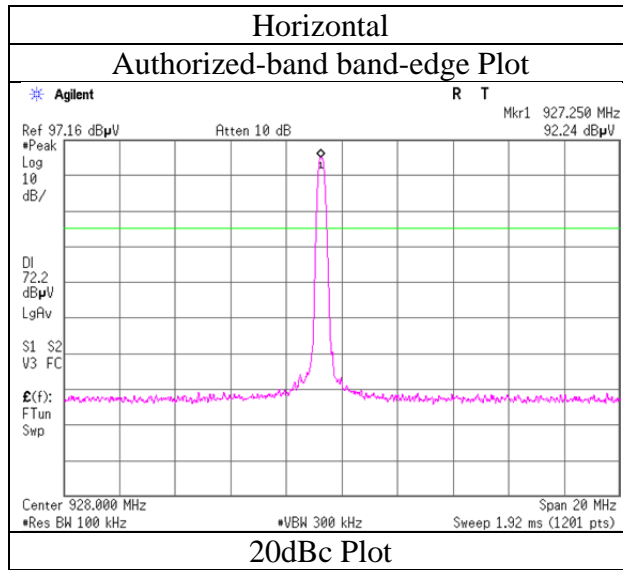

* Final result of restricted band edge was shown in tabular data.

Radiated Spurious Emission
Cable Antenna (1m)

Test place Ise EMC Lab. No.2 Semi Anechoic Chamber
Report No. 11397594H
Date December 20, 2016 December 21, 2016
Temperature / Humidity 23 deg. C / 31 % RH 24 deg. C / 32 % RH
Engineer Shinya Watanabe Shinya Watanabe
Above 1 GHz Below 1 GHz
Mode Tx, Hopping Off, 902.75 MHz

Polarity	Frequency [MHz]	Detector	Reading [dBuV]	Ant.Fac. [dB/m]	Loss [dB]	Gain [dB]	Result [dBuV/m]	Limit [dBuV/m]	Margin [dB]	Remark
Hori	1805.500	PK	49.1	26.6	4.9	35.2	45.4	73.9	28.5	
Hori	2708.250	PK	45.9	28.0	5.1	34.5	44.5	73.9	29.4	Floor noise
Hori	3611.000	PK	47.3	28.8	5.4	34.0	47.5	73.9	26.4	
Hori	4513.750	PK	49.3	30.6	5.8	34.0	51.7	73.9	22.2	
Hori	5416.500	PK	45.2	32.0	6.4	33.9	49.7	73.9	24.2	
Hori	6319.250	PK	44.3	33.9	6.9	34.1	51.0	73.9	22.9	Floor noise
Hori	7222.000	PK	44.7	36.1	7.1	34.1	53.8	73.9	20.1	Floor noise
Hori	8124.750	PK	43.9	36.9	7.2	34.3	53.7	73.9	20.2	Floor noise
Hori	9027.500	PK	44.5	37.5	7.5	34.6	54.9	73.9	19.0	Floor noise
Hori	1805.500	AV	39.0	26.6	4.9	35.2	35.3	53.9	18.6	
Hori	2708.250	AV	32.5	28.0	5.1	34.5	31.1	53.9	22.8	Floor noise
Hori	3611.000	AV	36.9	28.8	5.4	34.0	37.1	53.9	16.8	
Hori	4513.750	AV	42.9	30.6	5.8	34.0	45.3	53.9	8.6	
Hori	5416.500	AV	33.7	32.0	6.4	33.9	38.2	53.9	15.7	
Hori	6319.250	AV	31.4	33.9	6.9	34.1	38.1	53.9	15.8	Floor noise
Hori	7222.000	AV	31.8	36.1	7.1	34.1	40.9	53.9	13.0	Floor noise
Hori	8124.750	AV	31.7	36.9	7.2	34.3	41.5	53.9	12.4	Floor noise
Hori	9027.500	AV	32.0	37.5	7.5	34.6	42.4	53.9	11.5	Floor noise
Vert	1805.500	PK	48.8	26.6	4.9	35.2	45.1	73.9	28.8	
Vert	2708.250	PK	46.4	28.0	5.1	34.5	45.0	73.9	28.9	Floor noise
Vert	3611.000	PK	45.5	28.8	5.4	34.0	45.7	73.9	28.2	
Vert	4513.750	PK	47.1	30.6	5.8	34.0	49.5	73.9	24.4	
Vert	5416.500	PK	45.5	32.0	6.4	33.9	50.0	73.9	23.9	
Vert	6319.250	PK	44.2	33.9	6.9	34.1	50.9	73.9	23.0	Floor noise
Vert	7222.000	PK	44.4	36.1	7.1	34.1	53.5	73.9	20.4	Floor noise
Vert	8124.750	PK	44.4	36.9	7.2	34.3	54.2	73.9	19.7	Floor noise
Vert	9027.500	PK	43.3	37.5	7.5	34.6	53.7	73.9	20.2	Floor noise
Vert	1805.500	AV	37.6	26.6	4.9	35.2	33.9	53.9	20.0	
Vert	2708.250	AV	32.7	28.0	5.1	34.5	31.3	53.9	22.6	Floor noise
Vert	3611.000	AV	36.1	28.8	5.4	34.0	36.3	53.9	17.6	
Vert	4513.750	AV	37.0	30.6	5.8	34.0	39.4	53.9	14.5	
Vert	5416.500	AV	37.1	32.0	6.4	33.9	41.6	53.9	12.3	
Vert	6319.250	AV	31.5	33.9	6.9	34.1	38.2	53.9	15.7	Floor noise
Vert	7222.000	AV	31.7	36.1	7.1	34.1	40.8	53.9	13.1	Floor noise
Vert	8124.750	AV	31.7	36.9	7.2	34.3	41.5	53.9	12.4	Floor noise
Vert	9027.500	AV	32.2	37.5	7.5	34.6	42.6	53.9	11.3	Floor noise

Result = Reading + Ant Factor + Loss (Cable+Attenuator+Filter+Distance factor(above 1 GHz)) - Gain(Amplifier)

*Other frequency noises omitted in this report were not seen or had enough margin (more than 20 dB).

Distance factor: 1 GHz - 10 GHz $20\log(3.75\text{ m} / 3.0\text{ m}) = 1.94\text{ dB}$

***These results have sufficient margin without taking account Dwell time factor.**

20dBc Data Sheet

Polarity	Frequency [MHz]	Detector	Reading [dBuV]	Ant Factor [dB/m]	Loss [dB]	Gain [dB]	Result [dBuV/m]	Limit [dBuV/m]	Margin [dB]	Remark
Hori	902.750	PK	92.6	21.9	11.2	0.0	125.7	-	-	Carrier
Hori	671.999	PK	24.0	19.5	10.4	0.0	53.9	105.7	51.8	
Hori	902.000	PK	32.8	21.9	11.2	0.0	65.9	105.7	39.8	
Hori	941.155	PK	27.3	22.1	11.3	0.0	60.7	105.7	45.0	
Vert	902.750	PK	88.4	21.9	11.2	0.0	121.5	-	-	Carrier
Vert	671.999	PK	22.1	19.5	10.4	0.0	52.0	101.5	49.5	
Vert	902.000	PK	30.2	21.9	11.2	0.0	63.3	101.5	38.2	
Vert	941.155	PK	22.6	22.1	11.3	0.0	56.0	101.5	45.5	

Result = Reading + Ant Factor + Loss (Cable+Attenuator+Filter+Distance factor(above 1 GHz)) - Gain(Amplifier)

UL Japan, Inc.

Ise EMC Lab.

4383-326 Asama-cho, Ise-shi, Mie-ken 516-0021 JAPAN

Telephone : +81 596 24 8999

Facsimile : +81 596 24 8124

Radiated Spurious Emission
(Reference Plot for band-edge)
Cable Antenna (1m)

Test place	Ise EMC Lab. No.2 Semi Anechoic Chamber
Report No.	11397594H
Date	December 21, 2016
Temperature / Humidity	24 deg. C / 32 % RH
Engineer	Shinya Watanabe
	Below 1 GHz
Mode	Tx, Hopping Off, 902.75 MHz

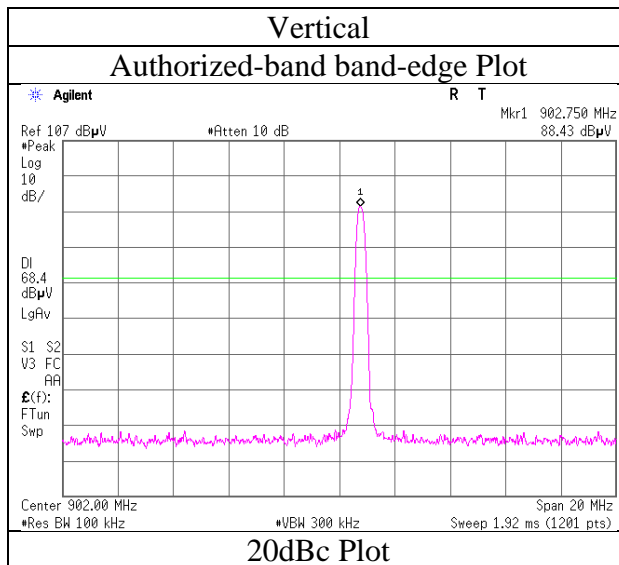
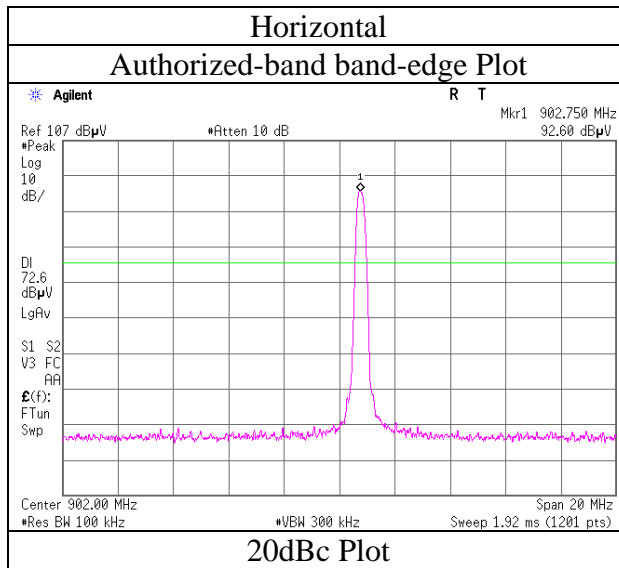

* Final result of restricted band edge was shown in tabular data.

Radiated Spurious Emission
Cable Antenna (1m)

Test place Ise EMC Lab. No.2 Semi Anechoic Chamber
Report No. 11397594H
Date December 20, 2016 December 21, 2016
Temperature / Humidity 23 deg. C / 31 % RH 24 deg. C / 32 % RH
Engineer Shinya Watanabe Shinya Watanabe
Above 1 GHz Below 1 GHz
Mode Tx, Hopping Off, 914.75 MHz

Polarity	Frequency [MHz]	Detector	Reading [dBuV]	Ant.Fac. [dB/m]	Loss [dB]	Gain [dB]	Result [dBuV/m]	Limit [dBuV/m]	Margin [dB]	Remark
Hori	1829.500	PK	48.2	26.7	4.9	35.2	44.6	73.9	29.3	
Hori	2744.250	PK	47.8	28.0	5.1	34.5	46.4	73.9	27.5	
Hori	3659.000	PK	47.8	28.9	5.5	33.9	48.3	73.9	25.6	
Hori	4573.750	PK	47.4	30.8	6.0	34.0	50.2	73.9	23.7	
Hori	5488.500	PK	44.5	32.0	6.4	33.9	49.0	73.9	24.9	
Hori	6403.250	PK	43.7	34.2	6.9	34.1	50.7	73.9	23.2	Floor noise
Hori	7318.000	PK	43.4	36.3	7.2	34.1	52.8	73.9	21.1	Floor noise
Hori	8232.750	PK	43.3	36.8	7.2	34.4	52.9	73.9	21.0	Floor noise
Hori	9147.500	PK	43.8	37.7	7.5	34.7	54.3	73.9	19.6	Floor noise
Hori	1829.500	AV	35.5	26.7	4.9	35.2	31.9	53.9	22.0	
Hori	2744.250	AV	35.3	28.0	5.1	34.5	33.9	53.9	20.0	
Hori	3659.000	AV	37.7	28.9	5.5	33.9	38.2	53.9	15.7	
Hori	4573.750	AV	38.5	30.8	6.0	34.0	41.3	53.9	12.6	
Hori	5488.500	AV	34.6	32.0	6.4	33.9	39.1	53.9	14.8	
Hori	6403.250	AV	31.1	34.2	6.9	34.1	38.1	53.9	15.8	Floor noise
Hori	7318.000	AV	31.5	36.3	7.2	34.1	40.9	53.9	13.0	Floor noise
Hori	8232.750	AV	31.5	36.8	7.2	34.4	41.1	53.9	12.8	Floor noise
Hori	9147.500	AV	31.8	37.7	7.5	34.7	42.3	53.9	11.6	Floor noise
Vert	1829.500	PK	48.5	26.7	4.9	35.2	44.9	73.9	29.0	
Vert	2744.250	PK	47.2	28.0	5.1	34.5	45.8	73.9	28.1	
Vert	3659.000	PK	47.5	28.9	5.5	33.9	48.0	73.9	25.9	
Vert	4573.750	PK	46.5	30.8	6.0	34.0	49.3	73.9	24.6	
Vert	5488.500	PK	46.6	32.0	6.4	33.9	51.1	73.9	22.8	
Vert	6403.250	PK	44.0	34.2	6.9	34.1	51.0	73.9	22.9	Floor noise
Vert	7318.000	PK	43.5	36.3	7.2	34.1	52.9	73.9	21.0	Floor noise
Vert	8232.750	PK	44.3	36.8	7.2	34.4	53.9	73.9	20.0	Floor noise
Vert	9147.500	PK	44.8	37.7	7.5	34.7	55.3	73.9	18.6	Floor noise
Vert	1829.500	AV	37.2	26.7	4.9	35.2	33.6	53.9	20.3	
Vert	2744.250	AV	34.4	28.0	5.1	34.5	33.0	53.9	20.9	
Vert	3659.000	AV	39.8	28.9	5.5	33.9	40.3	53.9	13.6	
Vert	4573.750	AV	35.1	30.8	6.0	34.0	37.9	53.9	16.0	
Vert	5488.500	AV	36.2	32.0	6.4	33.9	40.7	53.9	13.2	
Vert	6403.250	AV	31.1	34.2	6.9	34.1	38.1	53.9	15.8	Floor noise
Vert	7318.000	AV	31.5	36.3	7.2	34.1	40.9	53.9	13.0	Floor noise
Vert	8232.750	AV	31.5	36.8	7.2	34.4	41.1	53.9	12.8	Floor noise
Vert	9147.500	AV	31.9	37.7	7.5	34.7	42.4	53.9	11.5	Floor noise

Result = Reading + Ant Factor + Loss (Cable+Attenuator+Filter+Distance factor(above 1 GHz)) - Gain(Amplifier)

*Other frequency noises omitted in this report were not seen or had enough margin (more than 20 dB).

Distance factor: 1 GHz - 10 GHz $20\log(3.75\text{ m} / 3.0\text{ m}) = 1.94\text{ dB}$

***These results have sufficient margin without taking account Dwell time factor.**

20dBc Data Sheet

Polarity	Frequency [MHz]	Detector	Reading [dBuV]	Ant Factor [dB/m]	Loss [dB]	Gain [dB]	Result [dBuV/m]	Limit [dBuV/m]	Margin [dB]	Remark
Hori	914.750	PK	91.2	21.9	11.3	0.0	124.4	-	-	Carrier
Hori	895.550	PK	21.6	21.8	11.2	0.0	54.6	104.4	49.8	
Hori	933.945	PK	23.7	22.0	11.3	0.0	57.0	104.4	47.4	
Vert	914.750	PK	87.9	21.9	11.3	0.0	121.1	-	-	Carrier
Vert	895.550	PK	21.5	21.8	11.2	0.0	54.5	101.1	46.6	
Vert	933.945	PK	22.2	22.0	11.3	0.0	55.5	101.1	45.6	

Result = Reading + Ant Factor + Loss (Cable+Attenuator+Filter+Distance factor(above 1 GHz)) - Gain(Amplifier)

UL Japan, Inc.

Ise EMC Lab.

4383-326 Asama-cho, Ise-shi, Mie-ken 516-0021 JAPAN

Telephone : +81 596 24 8999

Facsimile : +81 596 24 8124

Radiated Spurious Emission
Cable Antenna (1m)

Test place Ise EMC Lab. No.2 Semi Anechoic Chamber
Report No. 11397594H
Date December 20, 2016 December 21, 2016
Temperature / Humidity 23 deg. C / 31 % RH 24 deg. C / 32 % RH
Engineer Shinya Watanabe Shinya Watanabe
Above 1 GHz Below 1 GHz
Mode Tx, Hopping Off, 927.25 MHz

Polarity	Frequency [MHz]	Detector	Reading [dBuV]	Ant.Fac. [dB/m]	Loss [dB]	Gain [dB]	Result [dBuV/m]	Limit [dBuV/m]	Margin [dB]	Remark
Hori	1854.500	PK	51.0	26.7	4.9	35.2	47.4	73.9	26.5	
Hori	2781.750	PK	46.0	28.1	5.2	34.5	44.8	73.9	29.1	
Hori	3709.000	PK	49.9	29.1	5.5	33.9	50.6	73.9	23.3	
Hori	4636.250	PK	46.0	31.0	6.0	34.0	49.0	73.9	24.9	Floor noise
Hori	5563.500	PK	44.4	32.1	6.4	33.9	49.0	73.9	24.9	Floor noise
Hori	6490.750	PK	43.6	34.5	7.0	34.1	51.0	73.9	22.9	Floor noise
Hori	7418.000	PK	43.7	36.4	7.2	34.1	53.2	73.9	20.7	Floor noise
Hori	8345.250	PK	43.4	36.7	7.3	34.4	53.0	73.9	20.9	Floor noise
Hori	9272.500	PK	45.1	38.0	7.6	34.7	56.0	73.9	17.9	Floor noise
Hori	1854.500	AV	45.6	26.7	4.9	35.2	42.0	53.9	11.9	
Hori	2781.750	AV	34.4	28.1	5.2	34.5	33.2	53.9	20.7	
Hori	3709.000	AV	43.4	29.1	5.5	33.9	44.1	53.9	9.8	
Hori	4636.250	AV	31.2	31.0	6.0	34.0	34.2	53.9	19.7	Floor noise
Hori	5563.500	AV	30.8	32.1	6.4	33.9	35.4	53.9	18.5	Floor noise
Hori	6490.750	AV	30.9	34.5	7.0	34.1	38.3	53.9	15.6	Floor noise
Hori	7418.000	AV	31.4	36.4	7.2	34.1	40.9	53.9	13.0	Floor noise
Hori	8345.250	AV	31.9	36.7	7.3	34.4	41.5	53.9	12.4	Floor noise
Hori	9272.500	AV	32.4	38.0	7.6	34.7	43.3	53.9	10.6	Floor noise
Vert	1854.500	PK	49.8	26.7	4.9	35.2	46.2	73.9	27.7	
Vert	2781.750	PK	47.5	28.1	5.2	34.5	46.3	73.9	27.6	
Vert	3709.000	PK	49.2	29.1	5.5	33.9	49.9	73.9	24.0	
Vert	4636.250	PK	45.5	31.0	6.0	34.0	48.5	73.9	25.4	Floor noise
Vert	5563.500	PK	47.0	32.1	6.4	33.9	51.6	73.9	22.3	
Vert	6490.750	PK	43.2	34.5	7.0	34.1	50.6	73.9	23.3	Floor noise
Vert	7418.000	PK	44.1	36.4	7.2	34.1	53.6	73.9	20.3	Floor noise
Vert	8345.250	PK	44.3	36.7	7.3	34.4	53.9	73.9	20.0	Floor noise
Vert	9272.500	PK	46.2	38.0	7.6	34.7	57.1	73.9	16.8	Floor noise
Vert	1854.500	AV	43.9	26.7	4.9	35.2	40.3	53.9	13.6	
Vert	2781.750	AV	37.2	28.1	5.2	34.5	36.0	53.9	17.9	
Vert	3709.000	AV	41.9	29.1	5.5	33.9	42.6	53.9	11.3	
Vert	4636.250	AV	31.6	31.0	6.0	34.0	34.6	53.9	19.3	Floor noise
Vert	5563.500	AV	35.3	32.1	6.4	33.9	39.9	53.9	14.0	
Vert	6490.750	AV	30.6	34.5	7.0	34.1	38.0	53.9	15.9	Floor noise
Vert	7418.000	AV	31.4	36.4	7.2	34.1	40.9	53.9	13.0	Floor noise
Vert	8345.250	AV	31.9	36.7	7.3	34.4	41.5	53.9	12.4	Floor noise
Vert	9272.500	AV	32.4	38.0	7.6	34.7	43.3	53.9	10.6	Floor noise

Result = Reading + Ant Factor + Loss (Cable+Attenuator+Filter+Distance factor(above 1 GHz)) - Gain(Amplifier)

*Other frequency noises omitted in this report were not seen or had enough margin (more than 20 dB).

Distance factor: 1 GHz - 10 GHz $20\log(3.75\text{ m} / 3.0\text{ m}) = 1.94\text{ dB}$

***These results have sufficient margin without taking account Dwell time factor.**

20dBc Data Sheet

Polarity	Frequency [MHz]	Detector	Reading [dBuV]	Ant Factor [dB/m]	Loss [dB]	Gain [dB]	Result [dBuV/m]	Limit [dBuV/m]	Margin [dB]	Remark
Hori	927.250	PK	91.5	22.0	11.3	0.0	124.8	-	-	Carrier
Hori	888.854	PK	21.9	21.7	11.2	0.0	54.8	104.8	50.0	
Hori	928.000	PK	30.3	22.0	11.3	0.0	63.6	104.8	41.2	
Vert	927.250	PK	84.7	22.0	11.3	0.0	118.0	-	-	Carrier
Vert	888.854	PK	21.7	21.7	11.2	0.0	54.6	98.0	43.4	
Vert	928.000	PK	27.3	22.0	11.3	0.0	60.6	98.0	37.4	

Result = Reading + Ant Factor + Loss (Cable+Attenuator+Filter+Distance factor(above 1 GHz)) - Gain(Amplifier)

UL Japan, Inc.

Ise EMC Lab.

4383-326 Asama-cho, Ise-shi, Mie-ken 516-0021 JAPAN

Telephone : +81 596 24 8999

Facsimile : +81 596 24 8124

Radiated Spurious Emission
(Reference Plot for band-edge)
Cable Antenna (1m)

Test place	Ise EMC Lab. No.2 Semi Anechoic Chamber
Report No.	11397594H
Date	December 21, 2016
Temperature / Humidity	24 deg. C / 32 % RH
Engineer	Shinya Watanabe
	Below 1 GHz
Mode	Tx, Hopping Off, 927.25 MHz

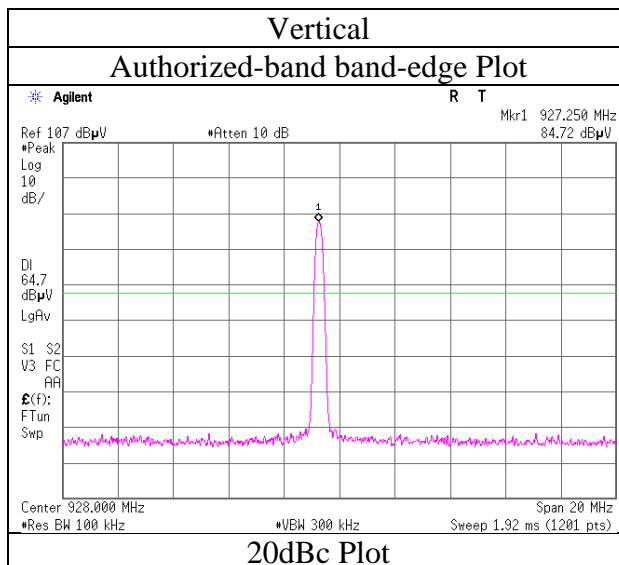
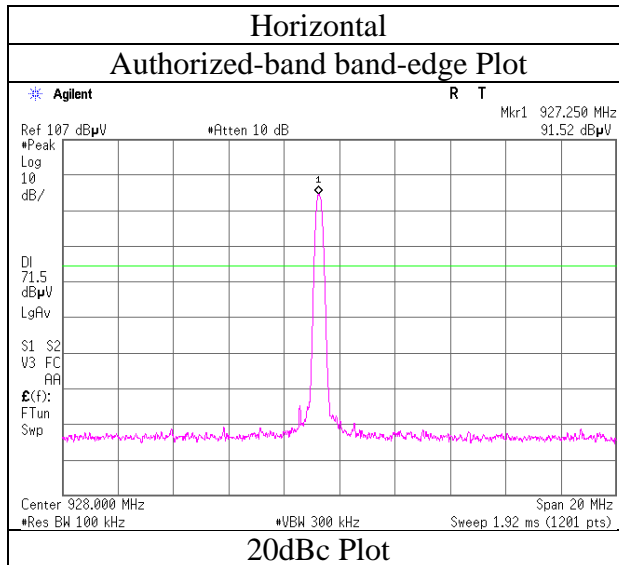

* Final result of restricted band edge was shown in tabular data.

Radiated Spurious Emission
(Plot data, Worst case)
Near field Loop Antenna without cable

Test place	Ise EMC Lab. No.2 Semi Anechoic Chamber	
Report No.	11397594H	
Date	December 19, 2016	December 21, 2016
Temperature / Humidity	24 deg. C / 43 % RH	25deg. C / 31% RH
Engineer	Hiroyuki Furutaka	
	Above 1 GHz	Below 1 GHz
Mode	Tx, Hopping Off, 902.75 MHz	

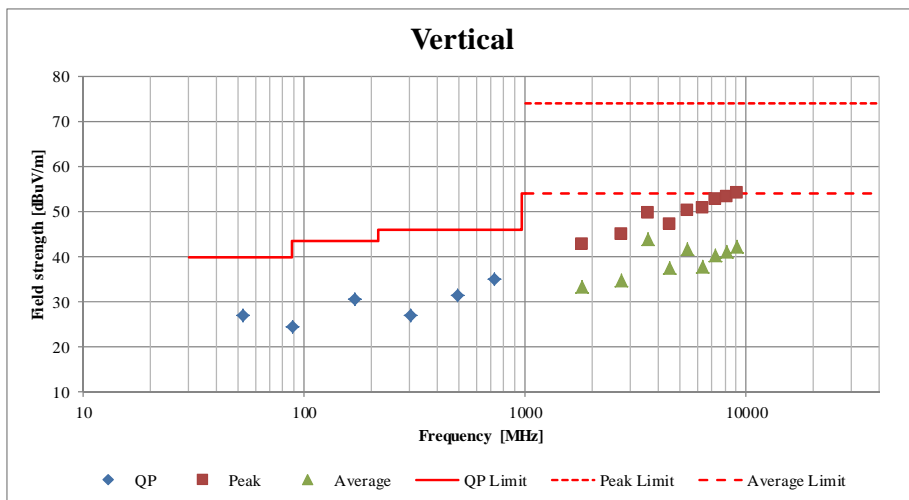
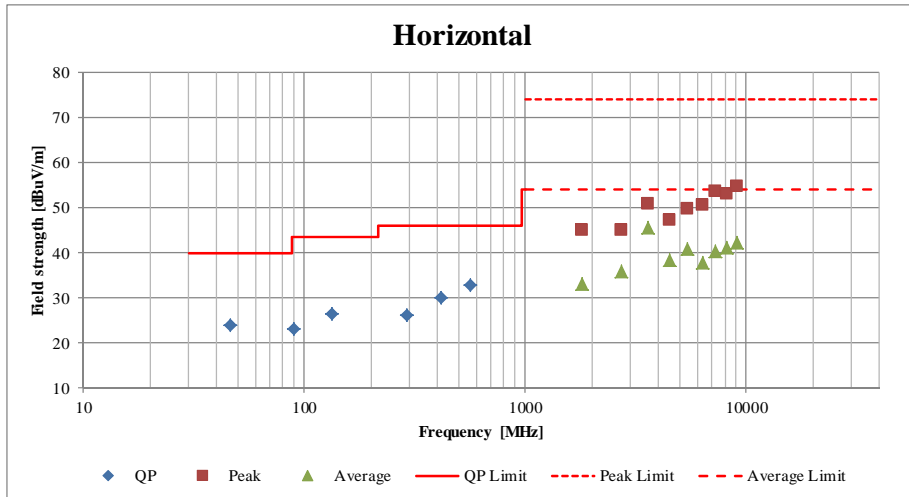

*These plots data contains sufficient number to show the trend of characteristic features for EUT.

Radiated Spurious Emission
(Plot data, Worst case)
Circular Polarized Antenna without cable

Test place	Ise EMC Lab. No.2 Semi Anechoic Chamber	
Report No.	11397594H	
Date	December 19, 2016	December 21, 2016
Temperature / Humidity	24 deg. C / 43 % RH	25deg. C / 31% RH
Engineer	Hiroyuki Furutaka	
	Above 1 GHz	Below 1 GHz
Mode	Tx, Hopping Off, 902.75 MHz	

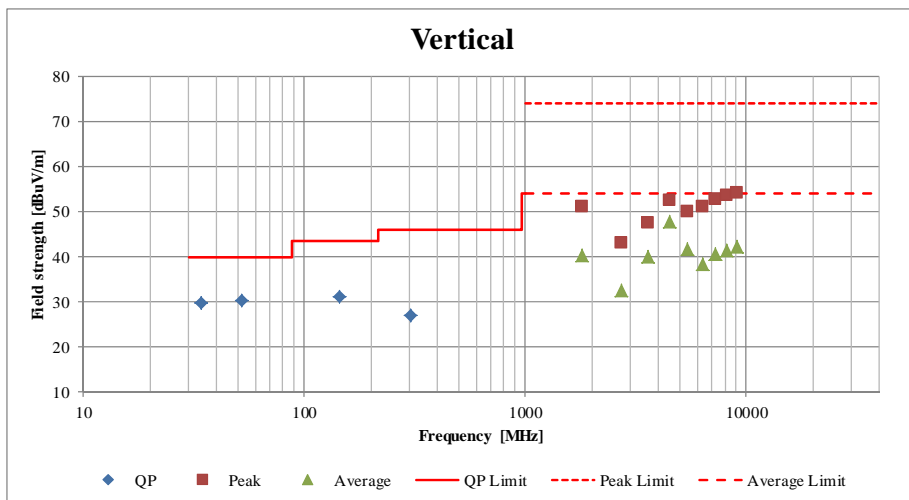
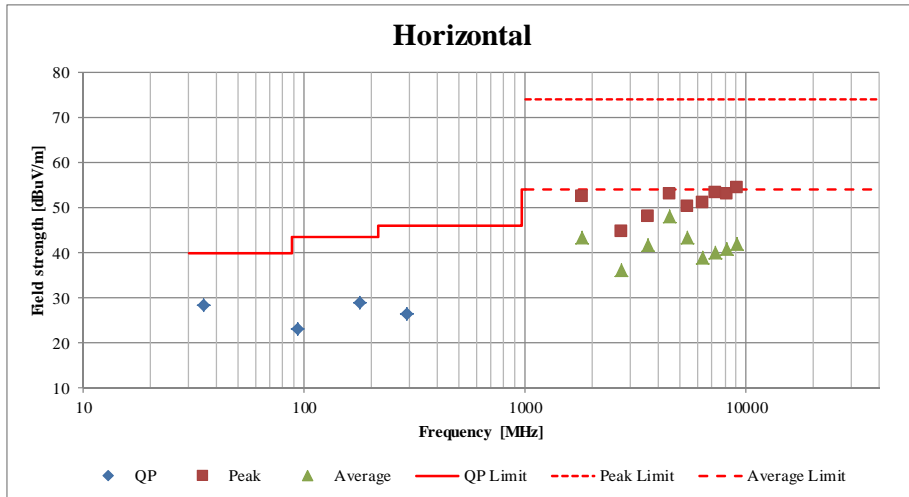

*These plots data contains sufficient number to show the trend of characteristic features for EUT.

Radiated Spurious Emission
(Plot data, Worst case)
Cable Antenna (1m)

Test place	Ise EMC Lab. No.2 Semi Anechoic Chamber	
Report No.	11397594H	
Date	December 20, 2016	December 21, 2016
Temperature / Humidity	23 deg. C / 31 % RH	24 deg. C / 32 % RH
Engineer	Shinya Watanabe	Shinya Watanabe
	Above 1 GHz	Below 1 GHz
Mode	Tx, Hopping Off, 902.75 MHz	

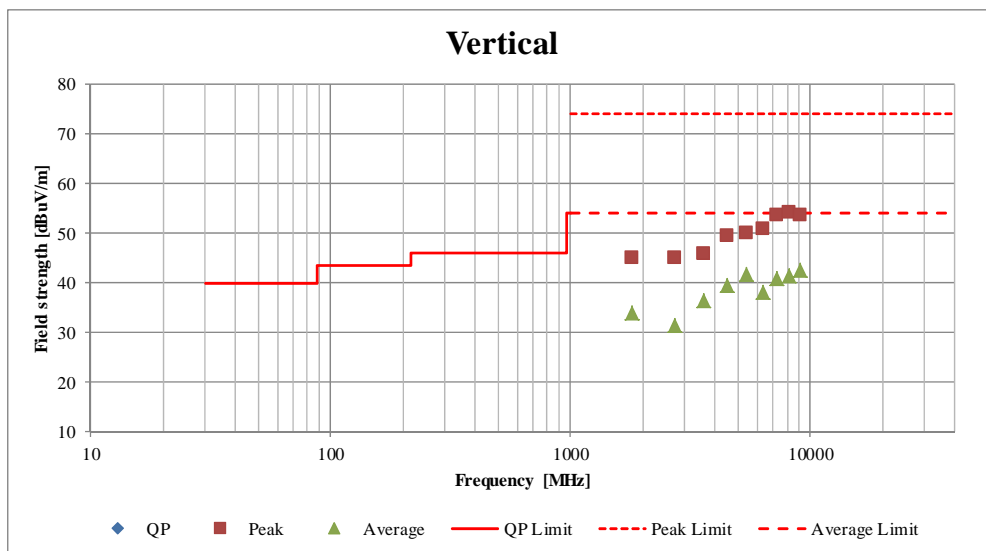
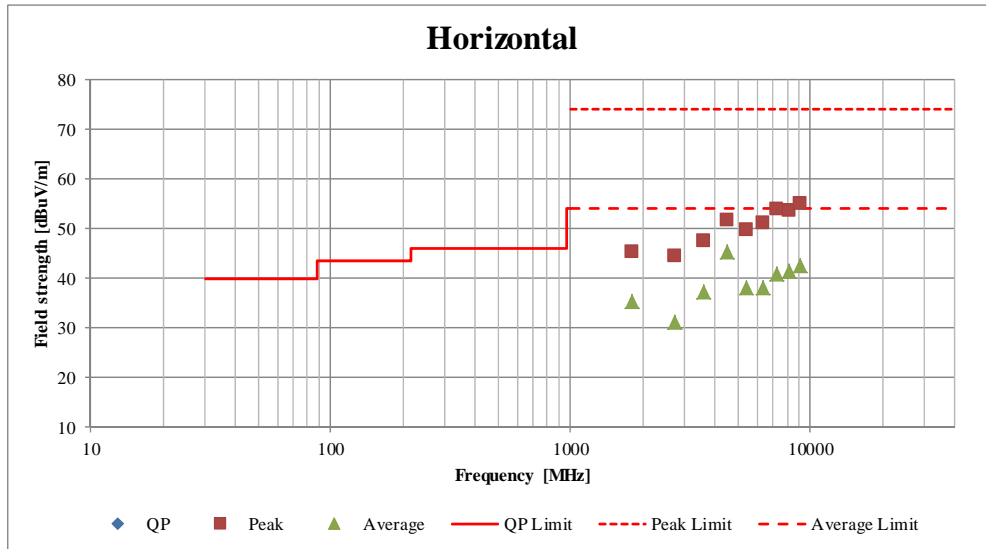

*These plots data contains sufficient number to show the trend of characteristic features for EUT.

UL Japan, Inc.

Ise EMC Lab.

4383-326 Asama-cho, Ise-shi, Mie-ken 516-0021 JAPAN

Telephone : +81 596 24 8999

Facsimile : +81 596 24 8124

Conducted Spurious Emission

Test place	Ise EMC Lab. No.2 Measurement Room
Report No.	11397594H
Date	December 22, 2016
Temperature / Humidity	20 deg. C / 45 % RH
Engineer	Ryota Yamanaka
Mode	Tx, Hopping Off, 902.75 MHz

902.75 MHz

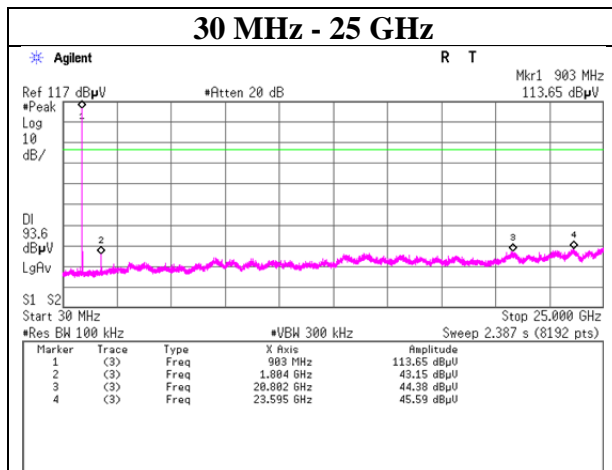
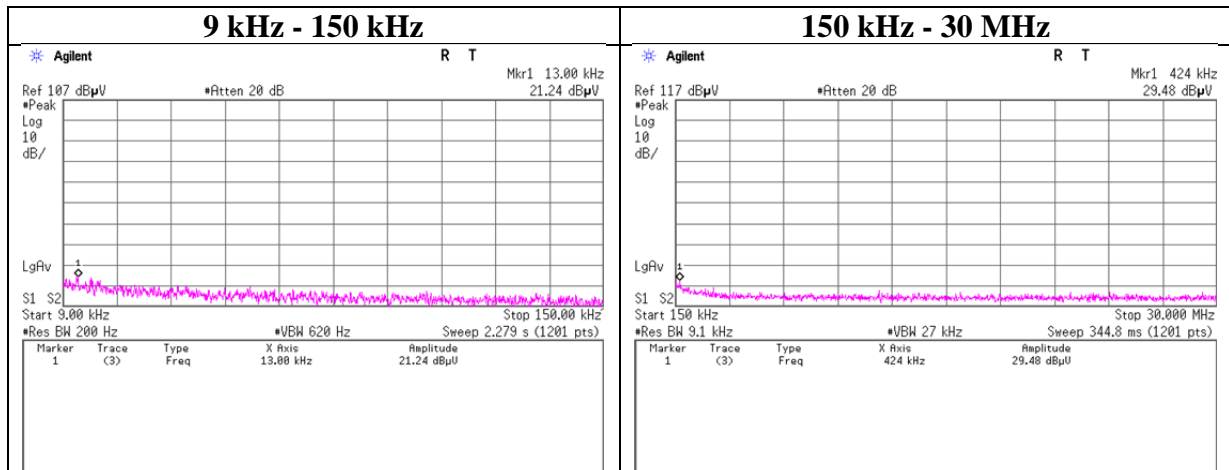

Conducted Spurious Emission

Test place	Ise EMC Lab. No.2 Measurement Room
Report No.	11397594H
Date	December 22, 2016
Temperature / Humidity	20 deg. C / 45 % RH
Engineer	Ryota Yamanaka
Mode	Tx, Hopping Off, 914.75 MHz

914.75 MHz

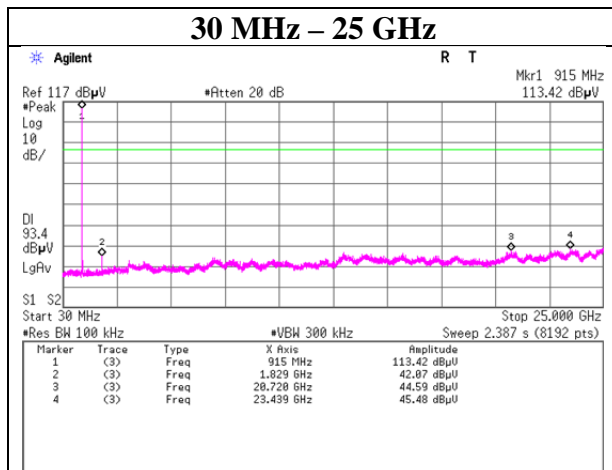
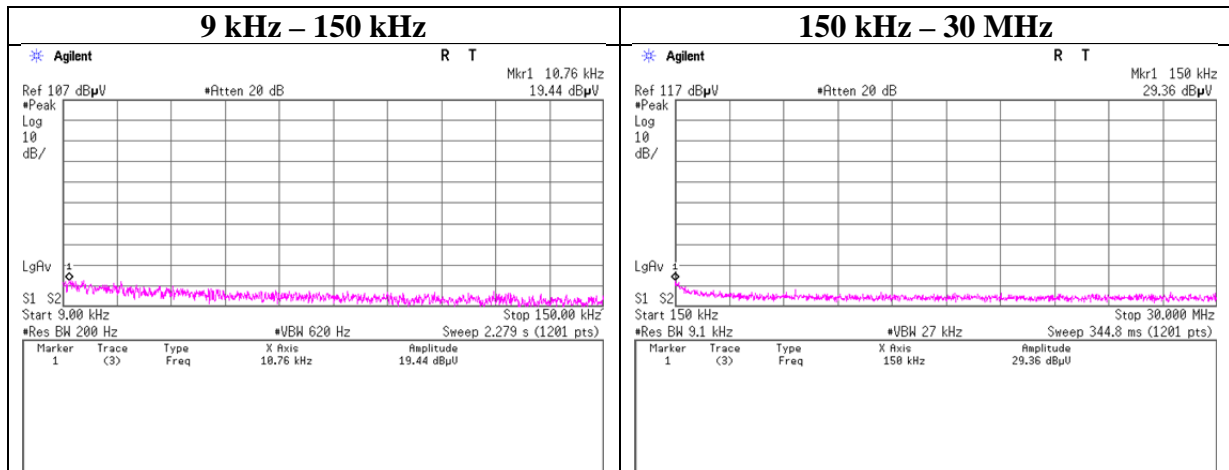

Conducted Spurious Emission

Test place	Ise EMC Lab. No.2 Measurement Room
Report No.	11397594H
Date	December 22, 2016
Temperature / Humidity	20 deg. C / 45 % RH
Engineer	Ryota Yamanaka
Mode	Tx, Hopping Off, 927.25 MHz

927.25 MHz

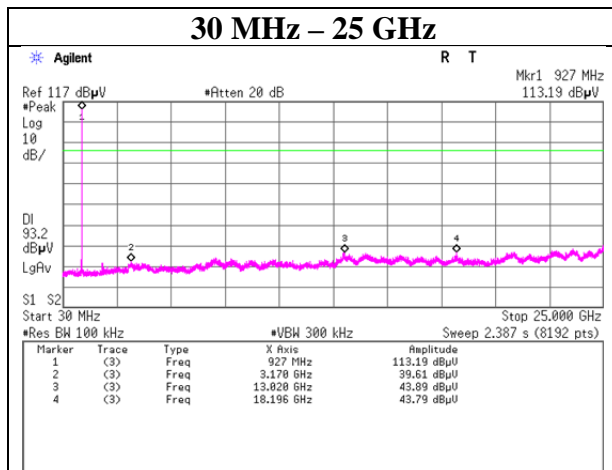
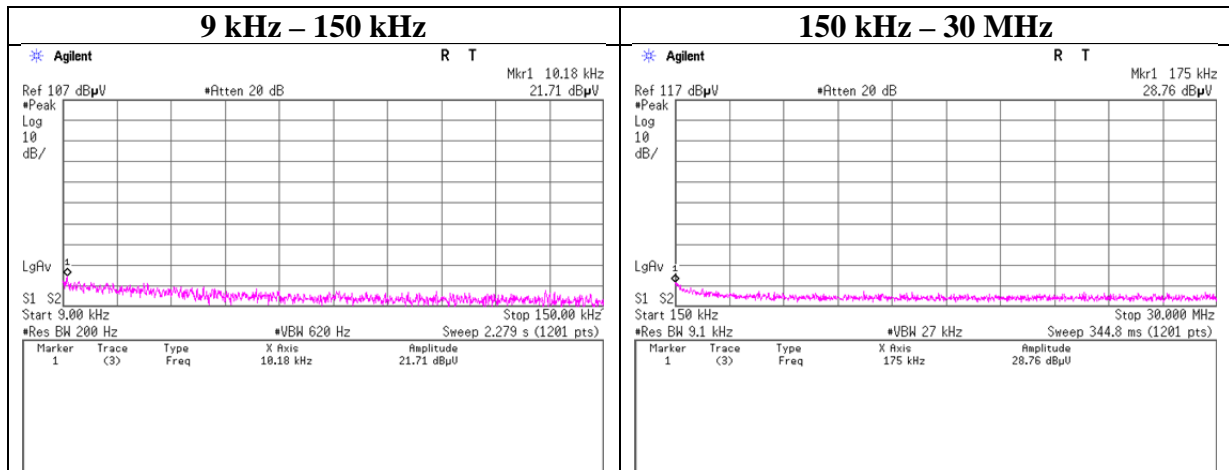

Conducted Emission Band Edge compliance

Test place	Ise EMC Lab. No.2 Measurement Room
Report No.	11397594H
Date	December 22, 2016
Temperature / Humidity	20 deg. C / 45 % RH
Engineer	Ryota Yamanaka
Mode	Tx Hopping Off / On

Hopping On

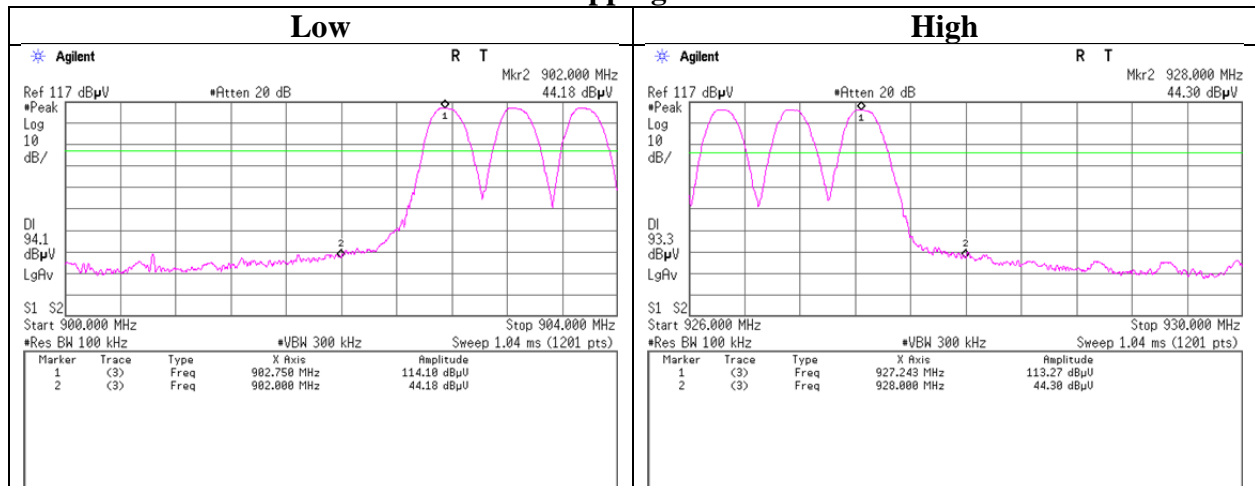

Hopping Off

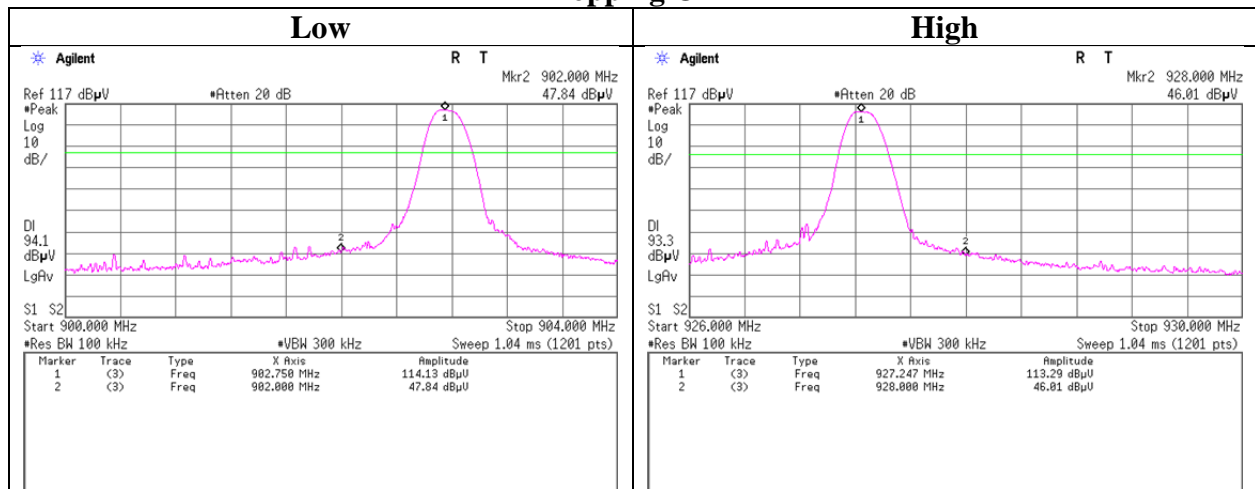

UL Japan, Inc.

Ise EMC Lab.

4383-326 Asama-cho, Ise-shi, Mie-ken 516-0021 JAPAN

Telephone : +81 596 24 8999

Facsimile : +81 596 24 8124

99%Occupied Bandwidth

Test place	Ise EMC Lab. No.2 Measurement Room
Report No.	11397594H
Date	December 22, 2016
Temperature / Humidity	20 deg. C / 45 % RH
Engineer	Ryota Yamanaka
Mode	Tx Hopping Off / On

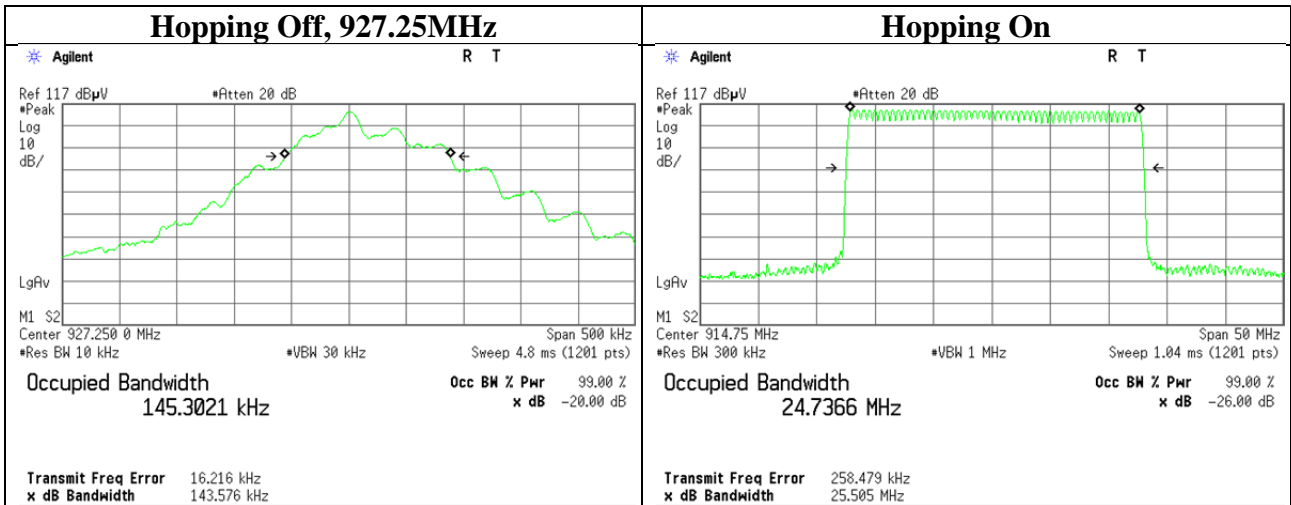
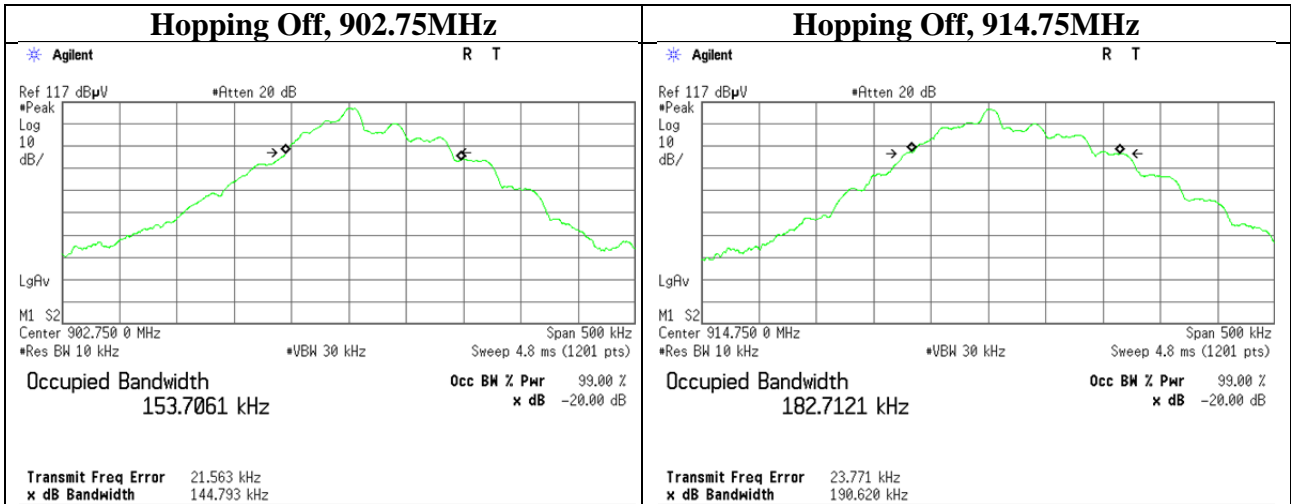

UL Japan, Inc.

Ise EMC Lab.

4383-326 Asama-cho, Ise-shi, Mie-ken 516-0021 JAPAN

Telephone : +81 596 24 8999

Facsimile : +81 596 24 8124

APPENDIX 2: Test instruments

Test equipment

Control No.	Instrument	Manufacturer	Model No	Serial No	Test Item	Calibration Date * Interval(month)
MAEC-02	Semi Anechoic Chamber(NSA)	TDK	Semi Anechoic Chamber 3m	DA-06902	RE/CE	2016/08/02 * 12
MOS-22	Thermo-Hygrometer	Custom	CTH-201	0003	RE/CE	2016/12/13 * 12
MJM-14	Measure	KOMELON	KMC-36	-	RE/CE	-
COTS-MEMI	EMI measurement program	TSJ	TEPTO-DV	-	RE/CE	-
MSA-04	Spectrum Analyzer	Agilent	E4448A	US44300523	RE/CE	2016/11/10 * 12
MHA-06	Horn Antenna 1-18GHz	Schwarzbeck	BBHA9120D	254	RE	2016/02/29 * 12
MCC-216	Microwave Cable	Junkosha	MWX221	1604S253(1 m) / 1608S087(5 m)	RE	2016/08/29 * 12
MPA-10	Pre Amplifier	Agilent	8449B	3008A02142	RE	2016/01/19 * 12
MMM-01	Digital Tester	Fluke	FLUKE 26-3	78030611	RE/CE	2016/08/23 * 12
MHF-27	High Pass Filter(1.1-10GHz)	TOKYO KEIKI	TF219CD1	1001	RE	2016/01/19 * 12
MBA-08	Biconical Antenna	Schwarzbeck	VHA9103B	08031	RE	2016/09/29 * 12
MLA-21	Logperiodic Antenna(200-1000MHz)	Schwarzbeck	VUSLP9111B	911B-190	RE	2016/01/30 * 12
MAT-07	Attenuator(6dB)	Weinschel Corp	2	BK7970	RE	2016/11/28 * 12
MCC-12	Coaxial Cable	Fujikura/Agilent	-	-	RE	2016/02/08 * 12
MPA-09	Pre Amplifier	Agilent	8447D	2944A10845	RE	2016/09/13 * 12
MTR-03	Test Receiver	Rohde & Schwarz	ESCI	100300	RE/CE	2016/10/21 * 12
MAT-10	Attenuator(10dB)	Weinschel Corp	2	BL1173	RE	2016/11/28 * 12
MLS-23	LISN(AMN)	Schwarzbeck	NSLK8127	8127-729	CE(EUT)	2016/07/07 * 12
MCC-13	Coaxial Cable	Fujikura	3D-2W(12m)/ 5D-2W(5m)/ 5D-2W(0.8m)/ 5D-2W(1m)	-	CE	2016/02/08 * 12
MAT-65	Attenuator(13dB)	JFW Industries, Inc.	50FP-013H2 N	-	CE	2016/12/21 * 12
MOS-19	Thermo-Hygrometer	Custom	CTH-201	0001	AT	2016/12/13 * 12
MRENT-130	Spectrum Analyzer	Agilent	E4440A	MY46187750	AT	2016/06/03 * 12
MAT-17	Attenuator(20dB)_ DC-1GHz_N	Weinschel Corp	MODEL 1	BG0143	AT	2016/12/24 * 12

The expiration date of the calibration is the end of the expired month.

All equipment is calibrated with valid calibrations. Each measurement data is traceable to the national or international standards.

As for some calibrations performed after the tested dates, those test equipment have been controlled by means of an unbroken chains of calibrations.

Test Item:
CE: Conducted Emission test
RE: Radiated Emission test
AT: Antenna Terminal Conducted test

UL Japan, Inc.

Ise EMC Lab.

4383-326 Asama-cho, Ise-shi, Mie-ken 516-0021 JAPAN

Telephone : +81 596 24 8999

Facsimile : +81 596 24 8124