



RADIO TEST REPORT

Test Report No. : 10124906H-A-R1

Applicant : Murata Manufacturing Company, Ltd.
Type of Equipment : Communication Module
Model No. : TypeYD
FCC ID : VPYLBYD
Test regulation : FCC Part 15 Subpart C: 2013
Test Result : Complied

1. This test report shall not be reproduced in full or partial, without the written approval of UL Japan, Inc.
2. The results in this report apply only to the sample tested.
3. This sample tested is in compliance with the above regulation.
4. The test results in this report are traceable to the national or international standards.
5. This test report must not be used by the customer to claim product certification, approval, or endorsement by NVLAP, NIST, or any agency of the Federal Government.
6. This report is a revised version of 10124906H-A. 10124906H-A is replaced with this report.

Date of test: December 25 to January 17, 2014

Representative test engineer:

T. Shimada

Takumi Shimada
Engineer of WiSE Japan,
UL Verification Service

Approved by:

T. Hatakeda

Takahiro Hatakeda
Leader of WiSE Japan,
UL Verification Service



NVLAP LAB CODE: 200572-0

This laboratory is accredited by the NVLAP LAB CODE 200572-0, U.S.A. The tests reported herein have been performed in accordance with its terms of accreditation.
*As for the range of Accreditation in NVLAP, you may refer to the WEB address,
<http://www.ul.com/japan/jpn/pages/services/emc/about/mark1/index.jsp#nvlap>

UL Japan, Inc.

Head Office EMC Lab.

4383-326 Asama-cho, Ise-shi, Mie-ken 516-0021 JAPAN

Telephone : +81 596 24 8999

Facsimile : +81 596 24 8124

13-EM-F0429

CONTENTS	PAGE
SECTION 1: Customer information.....	4
SECTION 2: Equipment under test (E.U.T.).....	4
SECTION 3: Test specification, procedures & results.....	5
SECTION 4: Operation of E.U.T. during testing.....	8
SECTION 5: Conducted Emission.....	10
SECTION 6: Radiated Spurious Emission	11
SECTION 7: Antenna Terminal Conducted Tests.....	12
APPENDIX 1: Data of EMI test.....	13
Conducted Emission	13
6dB Bandwidth	14
Maximum Peak Output Power	17
Radiated Spurious Emission	21
Conducted Spurious Emission	30
Power Density	31
99% Occupied Bandwidth	34
APPENDIX 2: Test instruments	36
APPENDIX 3: Photographs of test setup.....	37
Conducted Emission	37
Radiated Spurious Emission	38
Worst Case Position	39

UL Japan, Inc.

Head Office EMC Lab.

4383-326 Asama-cho, Ise-shi, Mie-ken 516-0021 JAPAN

Telephone : +81 596 24 8999

Facsimile : +81 596 24 8124

SECTION 1: Customer information

Company Name : Murata Manufacturing Company, Ltd.
Address : 10-1, Higashikotari 1-chome, Nagaokakyo-shi, Kyoto 617-8555 Japan
Telephone Number : +81-75-955-6375
Facsimile Number : +81-75-955-6634
Contact Person : Takaharu Kawakatsu

SECTION 2: Equipment under test (E.U.T.)

2.1 Identification of E.U.T.

Type of Equipment : Communication Module
Model No. : TypeYD
Serial No. : Refer to Section 4, Clause 4.2
Rating : DC3.3V
Receipt Date of Sample : December 11, 2013
Country of Mass-production : China/Japan
Condition of EUT : Engineering prototype
(Not for Sale: This sample is equivalent to mass-produced items.)
Modification of EUT : No Modification by the test lab

2.2 Product Description

Specification of WLAN (IEEE802.11b/g/n)

Type of radio	Wireless LAN (IEEE802.11b/g)	Wireless LAN (IEEE802.11n) 2.4G Band SISO (20M Band)
Equipment Type	Transceiver	
Frequency of Operation	2412MHz - 2462MHz	
Bandwidth & Channel spacing	Bandwidth : 20MHz Ch spacing : 5MHz	
Type of Modulation	11b: DSSS 11g: OFDM	OFDM
Antenna Type / Antenna Gain	Pattern antenna (Monopole antenna): -1.6dBi (Peak)	
Power Supply (inner)	DC 3.3V	
Operating temperature range	-20 to +70 deg. C.	

UL Japan, Inc.

Head Office EMC Lab.

4383-326 Asama-cho, Ise-shi, Mie-ken 516-0021 JAPAN

Telephone : +81 596 24 8999

Facsimile : +81 596 24 8124

SECTION 3: Test specification, procedures & results

3.1 Test Specification

Test Specification : FCC Part 15 Subpart C: 2013, final revised on September 30, 2013 and effective October 30, 2013

Title : FCC 47CFR Part15 Radio Frequency Device Subpart C Intentional Radiators
Section 15.207 Conducted limits
Section 15.247 Operation within the bands 902-928MHz,
2400-2483.5MHz, and 5725-5850MHz

3.2 Procedures and results

Item	Test Procedure	Specification	Worst margin	Results	Remarks
Conducted Emission	FCC: ANSI C63.4:2003 7. AC powerline Conducted Emission measurements ----- IC: RSS-Gen 7.2.4	FCC: Section 15.207 ----- IC: RSS-Gen 7.2.4	QP 10.6dB 4.83943MHz, N 4.84157MHz, L AV 11.0dB 4.83943MHz, N	Complied	-
6dB Bandwidth	FCC: "Guidance for Performing Compliance Measurements on Digital Transmission Systems (DTS) Operating Under §15.247(issued on April 9, 2013)" ----- IC: RSS-Gen 4.6.2	FCC: Section 15.247(a)(2) ----- IC: RSS-210 A8.2(a)	See data.	Complied	Conducted
Maximum Peak Output Power	FCC: "Guidance for Performing Compliance Measurements on Digital Transmission Systems (DTS) Operating Under §15.247(issued on April 9, 2013)" ----- IC: RSS-Gen 4.8	FCC: Section 15.247(b)(3) ----- IC: RSS-210 A8.4(4)		Complied	Conducted
Power Density	FCC: "Guidance for Performing Compliance Measurements on Digital Transmission Systems (DTS) Operating Under §15.247(issued on April 9, 2013)" ----- IC: -	FCC: Section 15.247 (e) ----- IC: RSS-210 A8.2(b)		Complied	Conducted
Spurious Emission Restricted Band Edges	FCC: "Guidance for Performing Compliance Measurements on Digital Transmission Systems (DTS) Operating Under §15.247(issued on April 9, 2013)" ----- IC: RSS-Gen 4.9	FCC: Section15.247(d) ----- IC: RSS-210 A8.5 RSS-Gen 7.2.3	0.5dB 456.016MHz, QP, Vert.	Complied	Conducted/ Radiated

Note: UL Japan, Inc.'s EMI Work Procedures No. 13-EM-W0420 and 13-EM-W0422.

* In case any questions arise about test procedure, ANSI C63.4: 2003 is also referred.

FCC 15.31 (e)

The stable voltage (DC3.3V) is constantly supplied to the EUT by the end product. Therefore, this EUT complies with the requirement.

FCC Part 15.203/212 Antenna requirement

It is impossible for end users to replace the antenna, because it is soldered on the circuit board. Therefore, the equipment complies with the antenna requirement of Section 15.203/212.

UL Japan, Inc.

Head Office EMC Lab.

4383-326 Asama-cho, Ise-shi, Mie-ken 516-0021 JAPAN

Telephone : +81 596 24 8999

Facsimile : +81 596 24 8124

3.3 Addition to standard

Item	Test Procedure	Specification	Worst margin	Results	Remarks
99% Occupied Bandwidth	IC: RSS-Gen 4.6.1	IC: RSS-Gen 4.6.1	N/A	-	Conducted

Other than above, no addition, exclusion nor deviation has been made from the standard.

3.4 Uncertainty

EMI

The following uncertainties have been calculated to provide a confidence level of 95% using a coverage factor k=2.

Test room (semi-anechoic chamber)	Conducted emission (+dB)
	150kHz-30MHz
No.1	3.5dB
No.2	3.5dB
No.3	3.6dB
No.4	3.5dB

Test room (semi-anechoic chamber)	Radiated emission						
	(3m*)(+dB)				(1m*)(+dB)		(0.5m*)(+dB)
	9kHz -30MHz	30MHz -300MHz	300MHz -1GHz	1GHz -10GHz	10GHz -18GHz	18GHz -26.5GHz	26.5GHz -40GHz
No.1	4.0dB	5.1dB	5.0dB	5.1dB	6.0dB	4.9dB	4.3dB
No.2	3.9dB	5.2dB	5.0dB	4.9dB	5.9dB	4.7dB	4.2dB
No.3	4.3dB	5.1dB	5.2dB	5.2dB	6.0dB	4.8dB	4.2dB
No.4	4.6dB	5.2dB	5.0dB	5.2dB	6.0dB	5.7dB	4.2dB

*3m/1m/0.5m = Measurement distance

Power meter (+dB)	
Below 1GHz	Above 1GHz
0.7dB	1.5dB

Antenna terminal conducted emission and Power density (+dB)			Antenna terminal conducted emission (+dB)		Channel power (±dB)
Below 1GHz	1GHz-3GHz	3GHz-18GHz	18GHz-26.5GHz	26.5GHz-40GHz	
1.5dB	1.7dB	2.8dB	2.8dB	2.9dB	2.6dB

Conducted Emission test

The data listed in this test report has enough margin, more than the site margin.

Radiated emission test (3m)

The data listed in this report meets the limits unless the uncertainty is taken into consideration.

UL Japan, Inc.

Head Office EMC Lab.

4383-326 Asama-cho, Ise-shi, Mie-ken 516-0021 JAPAN

Telephone : +81 596 24 8999

Facsimile : +81 596 24 8124

3.5 Test Location

UL Japan, Inc. Head Office EMC Lab. *NVLAP Lab. code: 200572-0
4383-326 Asama-cho, Ise-shi, Mie-ken 516-0021 JAPAN
Telephone : +81 596 24 8999 Facsimile : +81 596 24 8124

	FCC Registration Number	IC Registration Number	Width x Depth x Height (m)	Size of reference ground plane (m) / horizontal conducting plane	Other rooms
No.1 semi-anechoic chamber	313583	2973C-1	19.2 x 11.2 x 7.7m	7.0 x 6.0m	No.1 Power source room
No.2 semi-anechoic chamber	655103	2973C-2	7.5 x 5.8 x 5.2m	4.0 x 4.0m	-
No.3 semi-anechoic chamber	148738	2973C-3	12.0 x 8.5 x 5.9m	6.8 x 5.75m	No.3 Preparation room
No.3 shielded room	-	-	4.0 x 6.0 x 2.7m	N/A	-
No.4 semi-anechoic chamber	134570	2973C-4	12.0 x 8.5 x 5.9m	6.8 x 5.75m	No.4 Preparation room
No.4 shielded room	-	-	4.0 x 6.0 x 2.7m	N/A	-
No.5 semi-anechoic chamber	-	-	6.0 x 6.0 x 3.9m	6.0 x 6.0m	-
No.6 shielded room	-	-	4.0 x 4.5 x 2.7m	4.0 x 4.5 m	-
No.6 measurement room	-	-	4.75 x 5.4 x 3.0m	4.75 x 4.15 m	-
No.7 shielded room	-	-	4.7 x 7.5 x 2.7m	4.7 x 7.5m	-
No.8 measurement room	-	-	3.1 x 5.0 x 2.7m	N/A	-
No.9 measurement room	-	-	8.0 x 4.6 x 2.8m	2.4 x 2.4m	-
No.11 measurement room	-	-	6.2 x 4.7 x 3.0m	2.4 x 3.4m	-

* Size of vertical conducting plane (for Conducted Emission test) : 2.0 x 2.0m for No.1, No.2, No.3, and No.4 semi-anechoic chambers and No.3 and No.4 shielded rooms.

3.6 Data of EMI, Test instruments, and Test set up

Refer to APPENDIX.

UL Japan, Inc.

Head Office EMC Lab.

4383-326 Asama-cho, Ise-shi, Mie-ken 516-0021 JAPAN

Telephone : +81 596 24 8999

Facsimile : +81 596 24 8124

SECTION 4: Operation of E.U.T. during testing

4.1 Operating Mode(s)

Test operating mode was determined as follows according to “Section 1 of 6 802.11 a/b/g/n testing- Managing Complex Regulatory Approvals - ” of TCB Council Workshop October 2009.

Mode	Remarks*
IEEE 802.11b (11b)	5.5Mbps, PN9
IEEE 802.11g (11g)	36Mbps, PN9
IEEE 802.11n SISO 20MHz BW (11n-20)	MCS 0, PN9
*The worst condition was determined based on the test result of Maximum Peak Output Power (Mid Channel)	
*Power of the EUT was set by the software as follows; Power settings: 11b: 17dBm 11g: 13dBm 11n: 12dBm Software : mfgtest *This setting of software is the worst case. Any conditions under the normal use do not exceed the condition of setting. In addition, end users cannot change the settings of the output power of the product.	

*Details of Operating mode(s)

Test Item	Operating Mode	Tested frequency
Conducted Emission Spurious Emission (Conducted) Spurious Emission (Radiated below 1GHz)	11g Tx *1)	2412MHz
Spurious Emission (Radiated above 1GHz)	11b Tx 11g Tx *2)	2412MHz 2437MHz 2462MHz
Spurious Emission (Band Edge)	11b Tx 11g Tx 11n-20 Tx	2412MHz 2462MHz
6dB Bandwidth Maximum Peak Output Power Power Density 99% Occupied Bandwidth	11b Tx 11g Tx 11n-20 Tx	2412MHz 2437MHz 2462MHz
*1) The mode was tested as a representative, because it had the highest power at antenna terminal test. *2) Since 11g and 11n-20 have the same modulation method and no differences in transmitting specification, test was performed on the representative mode that had the higher peak output power.		

UL Japan, Inc.

Head Office EMC Lab.

4383-326 Asama-cho, Ise-shi, Mie-ken 516-0021 JAPAN

Telephone : +81 596 24 8999

Facsimile : +81 596 24 8124

4.2 Configuration and peripherals

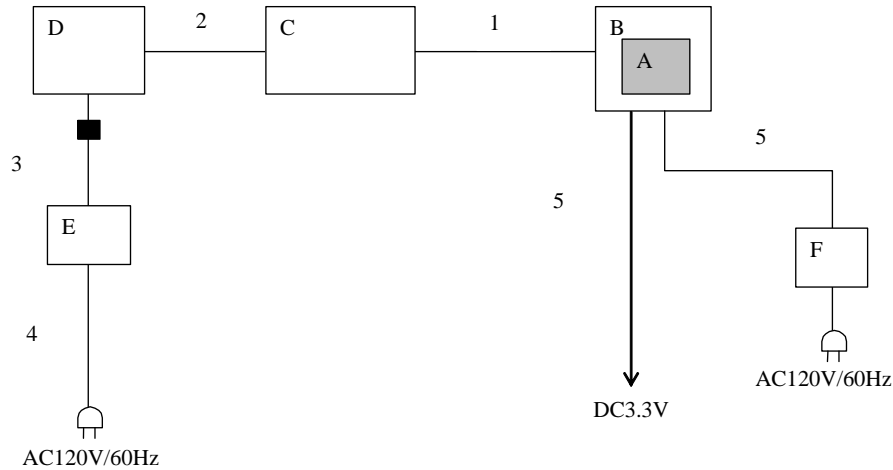

■: Standard Ferrite Core

* Cabling and setup(s) were taken into consideration and test data was taken under worse case conditions.

Description of EUT and Support equipment

No.	Item	Model number	Serial number	Manufacturer	Remarks
A	Communication Module	TypeYD	001 for AT* 002 for CE/RE*	MURATA	EUT
B	Jig board	-	-	-	-
C	Jig board	-	-	-	-
D	Laptop PC	T60	L3PM301	Lenovo	For CE*
	Laptop PC	FMV-C8230	R7305017	Fujitsu	For RE/AT*
E	AC Adaptor	92P1160	11S92P1160Z1ZBG H6B6DMX	Lenovo	For CE*
	AC Adaptor	FMV-AC319	05904888A	Fujitsu	For RE/AT*
F	DC Power Supply	PW18-1.3AT	08016530	KENWOOD TMI	For CE*

List of cables used

No.	Name	Length (m)	Shield		Remarks
			Cable	Connector	
1	Signal Cable	0.1	Unshielded	Unshielded	-
2	USB Cable	1.5	Shielded	Shielded	-
3	DC Cable	1.9 for CE* 1.8 for RE/AT*	Unshielded	Unshielded	-
4	AC Cable	1.0 for CE* 1.9 for RE/AT*	Unshielded	Unshielded	-
5	DC Cable	2.8	Unshielded	Unshielded	-
6	AC Cable	2.2	Unshielded	Unshielded	-

*CE: Conducted Emission, RE: Radiated Emission, AT: Antenna Terminal Conducted Test

UL Japan, Inc.

Head Office EMC Lab.

4383-326 Asama-cho, Ise-shi, Mie-ken 516-0021 JAPAN

Telephone : +81 596 24 8999

Facsimile : +81 596 24 8124

SECTION 5: Conducted Emission

Test Procedure and conditions

EUT was placed on a urethane platform of nominal size, 1.0m by 1.5m, raised 0.8m above the conducting ground plane.

The rear of tabletop was located 40cm to the vertical conducting plane. The rear of EUT, including peripherals aligned and flushed with rear of tabletop. All other surfaces of tabletop were at least 80cm from any other grounded conducting surface. EUT was located 80cm from a Line Impedance Stabilization Network (LISN)/ Artificial mains Network (AMN) and excess AC cable was bundled in center.

For the tests on EUT with other peripherals (as a whole system)

I/O cables that were connected to the peripherals were bundled in center. They were folded back and forth forming a bundle 30cm to 40cm long and were hanged at a 40cm height to the ground plane. All unused 50ohm connectors of the LISN(AMN) were resistivity terminated in 50ohm when not connected to the measuring equipment.

The AC Mains Terminal Continuous disturbance Voltage has been measured with the EUT in a Semi Anechoic Chamber.

The EUT was connected to a LISN (AMN).

An overview sweep with peak detection has been performed.

The test results and limit are rounded off to one decimal place, so some differences might be observed.

Detector	: QP and CISPR AV
Measurement range	: 0.15-30MHz
Test data	: APPENDIX
Test result	: Pass

UL Japan, Inc.

Head Office EMC Lab.

4383-326 Asama-cho, Ise-shi, Mie-ken 516-0021 JAPAN

Telephone : +81 596 24 8999

Facsimile : +81 596 24 8124

SECTION 6: Radiated Spurious Emission

Test Procedure

It was measured based on "11.0 Emissions in non-restricted frequency bands" of "Guidance for Performing Compliance Measurements on Digital Transmission Systems (DTS) Operating Under §15.247 (Issued on April 9, 2013)".

EUT was placed on a urethane platform of nominal size, 0.5m by 1.0m, raised 0.8m above the conducting ground plane.

The Radiated Electric Field Strength has been measured in a Semi Anechoic Chamber with a ground plane.

The height of the measuring antenna varied between 1 and 4m and EUT was rotated a full revolution in order to obtain the maximum value of the electric field strength.

The measurements were performed for both vertical and horizontal antenna polarization with the Test Receiver, or the Spectrum Analyzer.

The measurements were made with the following detector function of the test receiver and the Spectrum analyzer (in linear mode).

The test was made with the detector (RBW/VBW) in the following table.

When using Spectrum analyzer, the test was made with adjusting span to zero by using peak hold.

Test Antennas are used as below;

Frequency	30MHz to 300MHz	300MHz to 1GHz	Above 1GHz
Antenna Type	Biconical	Logperiodic	Horn

In any 100kHz bandwidth outside the restricted band in which the spread spectrum intentional radiator is operating, the radio frequency power that is produced by the intentional radiator confirmed 20dB below that in the 100kHz bandwidth within the band that contains the highest level of the desired power, based on a radiated measurement.

20dBc was applied to the frequency over the limit of FCC 15.209 / Table 5 of RSS-Gen 7.2.5(IC) and outside the restricted band of FCC15.205 / Table 3 of RSS-Gen 7.2.2 (IC).

Frequency	Below 1GHz	Above 1GHz		20dBc
Instrument used	Test Receiver	Spectrum Analyzer		Spectrum Analyzer
Detector	QP	PK	AV *1)	PK
IF Bandwidth	BW 120kHz(T/R)	RBW: 1MHz VBW: 3MHz	Average Power Method: <u>WLAN: 12.2.5.1/12.2.5.2</u> RBW: 1MHz VBW: 3MHz Detector: Power Averaging (RMS) Trace: Free Run	RBW: 100kHz VBW: 300kHz (S/A)
Test Distance	3m	3m (below 10GHz), 1m *2) (above 10GHz)		3m (below 10GHz), 1m *2) (above 10GHz)

*1) Average Power Measurement was performed based on 6.0 & 12.2.5 of "Guidance for Performing Compliance Measurements on Digital Transmission Systems (DTS) Operating Under §15.247 (Issued on April 9, 2013)"

*2) Distance Factor: $20 \times \log(3.0\text{m}/1.0\text{m}) = 9.5\text{dB}$

- The carrier level and noise levels were confirmed at each position of X, Y and Z axes of EUT to see the position of maximum noise, and the test was made at the position that has the maximum noise.

The test results and limit are rounded off to one decimal place, so some differences might be observed.

Measurement range : 30M-26.5GHz
Test data : APPENDIX
Test result : Pass

UL Japan, Inc.

Head Office EMC Lab.

4383-326 Asama-cho, Ise-shi, Mie-ken 516-0021 JAPAN

Telephone : +81 596 24 8999

Facsimile : +81 596 24 8124

SECTION 7: Antenna Terminal Conducted Tests

Test Procedure

The tests were made with below setting connected to the antenna port.

Test	Span	RBW	VBW	Sweep time	Detector	Trace	Instrument used
6dB Bandwidth	20MHz	100kHz	300kHz	Auto	Peak	Max Hold	Spectrum Analyzer
99% Occupied Bandwidth	Enough width to display 20dB Bandwidth	1 to 3% of Span	Three times of RBW	Auto	Peak	Max Hold*1)	Spectrum Analyzer
Maximum Peak Output Power	-	-	-	Auto	Peak/ Average *2)	-	Power Meter (Sensor: 50MHz BW)
Peak Power Density	1.5 times the 6dB Bandwidth	3kHz	10kHz	1.339sec 2.488sec	Peak	Max Hold	Spectrum Analyzer *3)
Conducted Spurious Emission *4)	9kHz to 150kHz	200Hz	620Hz	Auto	Peak	Max Hold	Spectrum Analyzer
	150kHz to 30MHz	9.1kHz	27kHz				

*1) The measurement was performed with Max Hold since the duty cycle was not 100%.
*2) Reference data
*3) Section 10.2 Method PKPSD (peak PSD) of "Guidance for Performing Compliance Measurements on Digital Transmission Systems (DTS) Operating Under §15.247 (Issued on April 9, 2013)".
*4) In the frequency range below 30MHz, RBW was narrowed to separate the noise contents. Then, wide-band noise near the limit was checked separately, however the noise was not detected as shown in the chart.(9kHz-150kHz:RBW=200Hz, 150kHz-30MHz:RBW=9.1kHz)

The test results and limit are rounded off to two decimals place, so some differences might be observed.

Test data : APPENDIX
Test result : Pass

APPENDIX 1: Data of EMI test

Conducted Emission

DATA OF CONDUCTED EMISSION TEST

UL Japan, Inc. Head Office EMC Lab. No.2 Semi Anechoic Chamber
Date : 2014/01/17

Report No. : 10124906H
Power : AC 120V / 60Hz
Temp./Humi. : 22deg. C / 33% RH
Engineer : Kazuya Yoshioka

Mode / Remarks : Tx 11g 2412MHz 36Mbps

Limit1 : FCC15.207 QP
Limit2 : FCC15.207 AV

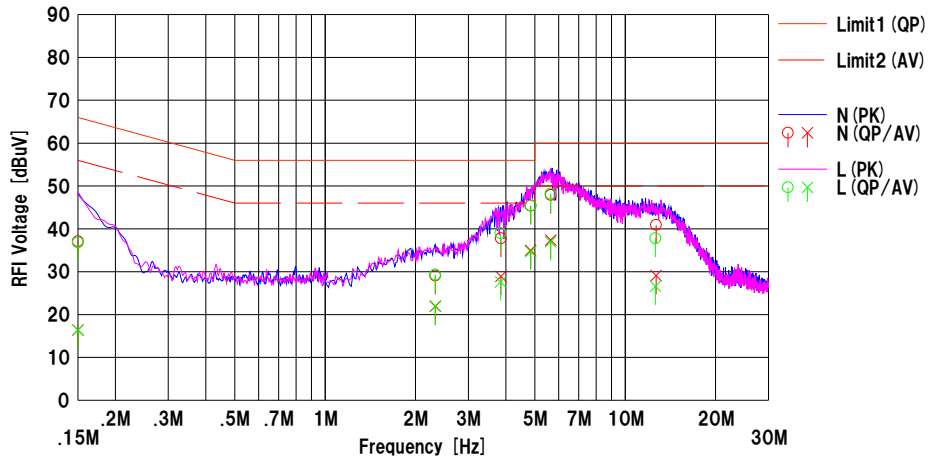

No.	Freq. [MHz]	Reading		C.Fac [dB]	Results		Limit		Margin		Phase	Comment
		<QP> [dBuV]	<AV> [dBuV]		<QP> [dBuV]	<AV> [dBuV]	<QP> [dBuV]	<AV> [dBuV]	<QP> [dB]	<AV> [dB]		
1	0.15000	23.9	3.2	13.2	37.1	15.4	56.0	56.0	28.9	39.6	N	
2	2.32869	15.6	8.4	13.5	29.1	21.9	56.0	46.0	26.9	24.1	N	
3	3.85160	24.0	15.1	13.8	37.8	28.9	56.0	46.0	18.2	17.1	N	
4	4.83943	31.5	21.1	13.9	45.4	35.0	56.0	46.0	10.6	11.0	N	
5	5.64335	33.9	23.4	14.0	47.9	37.4	60.0	50.0	12.1	12.6	N	
6	12.67043	26.3	14.5	14.6	40.9	29.1	60.0	50.0	19.1	20.9	N	
7	0.15000	23.6	3.2	13.2	36.8	16.4	66.0	56.0	29.2	39.6	L	
8	2.32945	15.8	8.5	13.5	29.3	22.0	56.0	46.0	26.7	24.0	L	
9	3.84402	25.2	13.8	13.8	39.0	27.6	56.0	46.0	17.0	18.4	L	
10	4.84157	31.5	20.8	13.9	45.4	34.7	56.0	46.0	10.6	11.3	L	
11	5.63745	34.2	23.0	14.0	48.2	37.0	60.0	50.0	11.8	13.0	L	
12	12.61023	23.2	12.0	14.6	37.8	26.6	60.0	50.0	22.2	23.4	L	

CHART:WITH FACTOR.Peak hold data. CALCULATION:RESULT=READING+C.F (LISN LOSS+ATT LOSS +CABLE LOSS)
Except for the above table : adequate margin data below the limits.

UL Japan, Inc.

Head Office EMC Lab.

4383-326 Asama-cho, Ise-shi, Mie-ken 516-0021 JAPAN

Telephone : +81 596 24 8999

Facsimile : +81 596 24 8124

6dB Bandwidth

Test place Head Office EMC Lab. No.6 Measurement Room
Report No. 10124906H
Date 12/25/2013
Temperature/ Humidity 20 deg.C./ 31%
Engineer Keisuke Kawamura
Mode Tx

11b

Frequency [MHz]	6dB Bandwidth [MHz]	Limit [kHz]
2412	7.910	>500
2437	8.460	>500
2462	8.005	>500

11g

Frequency [MHz]	6dB Bandwidth [MHz]	Limit [kHz]
2412	15.702	>500
2437	15.432	>500
2462	15.717	>500

11n-20

Frequency [MHz]	6dB Bandwidth [MHz]	Limit [kHz]
2412	15.983	>500
2437	15.127	>500
2462	15.098	>500

UL Japan, Inc.

Head Office EMC Lab.

4383-326 Asama-cho, Ise-shi, Mie-ken 516-0021 JAPAN

Telephone : +81 596 24 8999

Facsimile : +81 596 24 8124

6dB Bandwidth

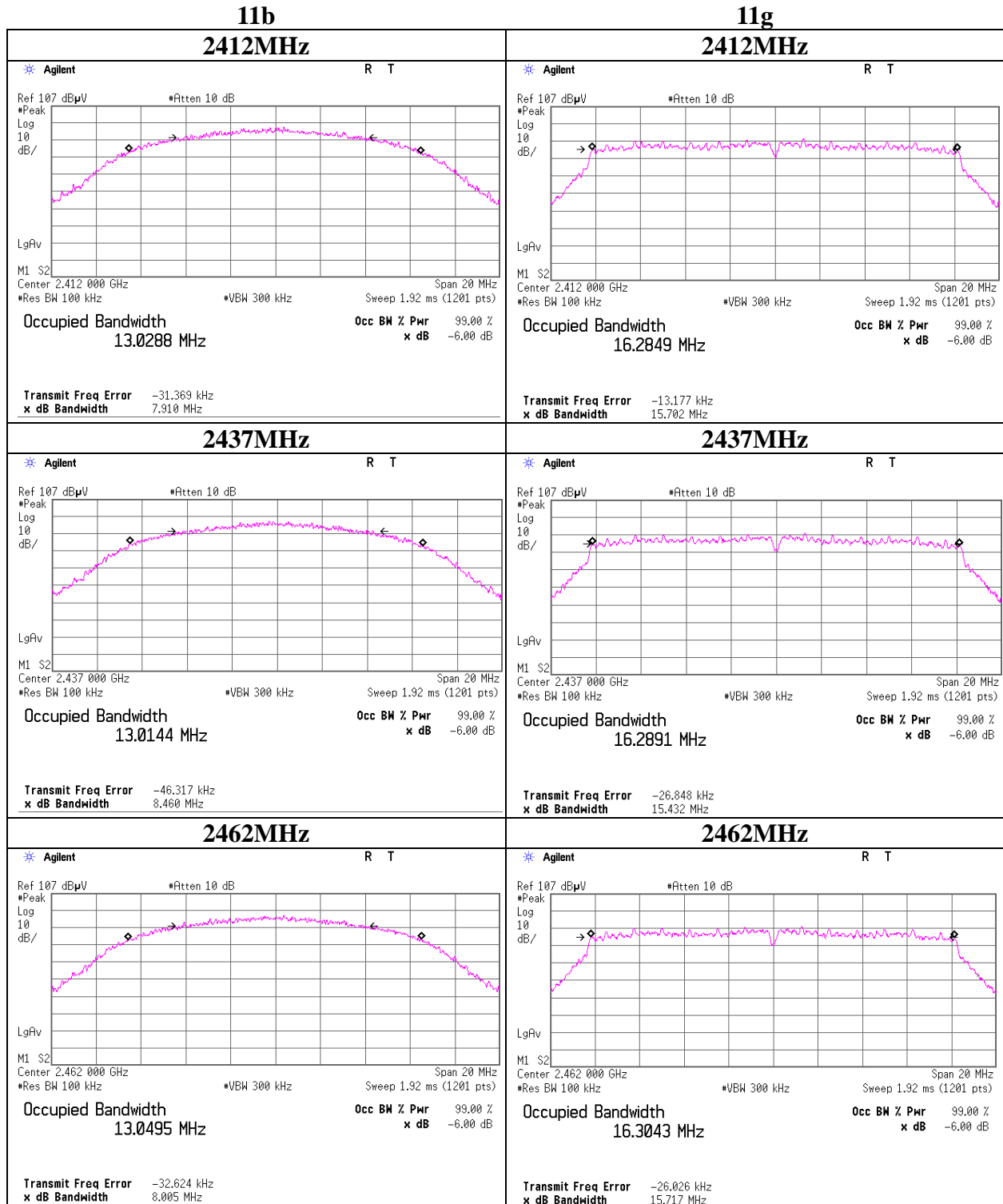

6dB Bandwidth

11n-20

2412MHz

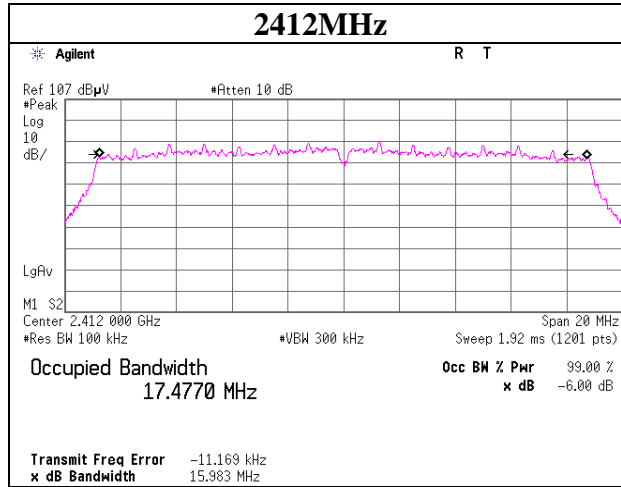

2437MHz

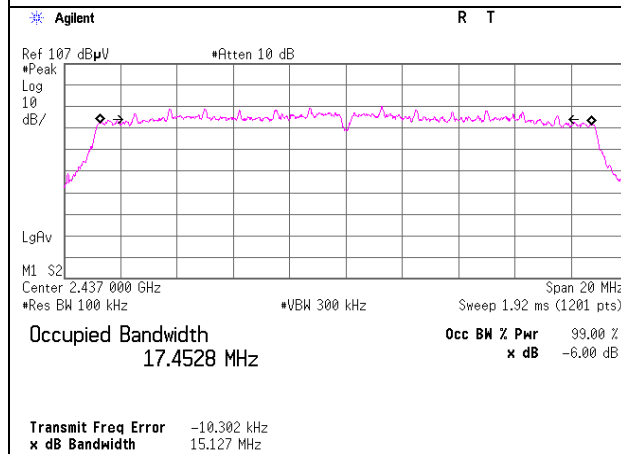

2462MHz

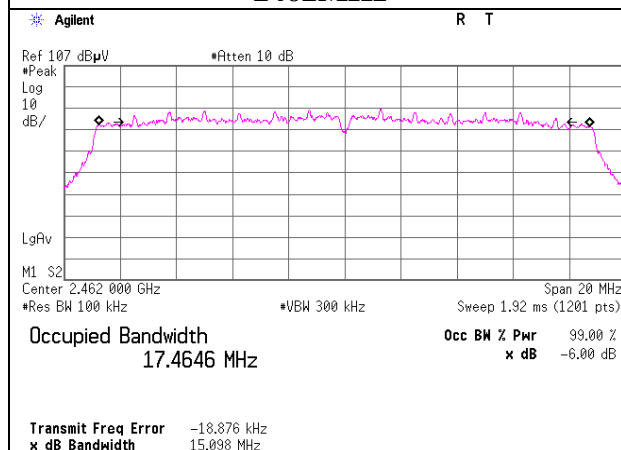

UL Japan, Inc.

Head Office EMC Lab.

4383-326 Asama-cho, Ise-shi, Mie-ken 516-0021 JAPAN

Telephone : +81 596 24 8999

Facsimile : +81 596 24 8124

Maximum Peak Output Power

Test place : Head Office EMC Lab. No.6 Measurement Room
 Report No. : 10124906H
 Date : 12/25/2013
 Temperature/ Humidity : 20 deg.C./ 31%
 Engineer : Keisuke Kawamura
 Mode : 11b Tx

Freq. [MHz]	Reading [dBm]	Cable Loss [dB]	Atten. [dB]	Result		Limit		Margin [dB]
				[dBm]	[mW]	[dBm]	[mW]	
2412	7.78	1.77	10.01	19.56	90.36	30.00	1000	10.44
2437	7.58	1.77	10.01	19.36	86.30	30.00	1000	10.64
2462	7.66	1.78	10.01	19.45	88.10	30.00	1000	10.55

Sample Calculation:

Result = Reading + Cable Loss (including the cable(s) customer supplied) + Attenuator

2437MHz

Rate [Mbps]	Reading [dBm]	Remark
1	7.51	
2	7.56	
5.5	7.58	*
11	7.53	

*: Worst Rate

All comparizon were carried out on same frequency and measurement factors.

UL Japan, Inc.

Head Office EMC Lab.

4383-326 Asama-cho, Ise-shi, Mie-ken 516-0021 JAPAN

Telephone : +81 596 24 8999

Facsimile : +81 596 24 8124

Maximum Peak Output Power

Test place : Head Office EMC Lab. No.6 Measurement Room
 Report No. : 10124906H
 Date : 12/25/2013
 Temperature/ Humidity : 20 deg.C./ 31%
 Engineer : Keisuke Kawamura
 Mode : 11g Tx

Freq. [MHz]	Reading [dBm]	Cable Loss [dB]	Atten. [dB]	Result		Limit		Margin [dB]
				[dBm]	[mW]	[dBm]	[mW]	
2412	11.95	1.77	10.01	23.73	236.05	30.00	1000	6.27
2437	11.74	1.77	10.01	23.52	224.91	30.00	1000	6.48
2462	11.41	1.78	10.01	23.20	208.93	30.00	1000	6.80

Sample Calculation:

Result = Reading + Cable Loss (including the cable(s) customer supplied) + Attenuator

2437MHz

Rate [Mbps]	Reading [dBm]	Remark
6	11.41	
9	11.35	
12	11.13	
18	11.20	
24	11.10	
36	11.74	*
48	11.36	
54	11.02	

*: Worst Rate

All comparison were carried out on same frequency and measurement factors.

UL Japan, Inc.

Head Office EMC Lab.

4383-326 Asama-cho, Ise-shi, Mie-ken 516-0021 JAPAN

Telephone : +81 596 24 8999

Facsimile : +81 596 24 8124

Maximum Peak Output Power

Test place : Head Office EMC Lab. No.6 Measurement Room
 Report No. : 10124906H
 Date : 12/25/2013
 Temperature/ Humidity : 20 deg.C./ 31%
 Engineer : Keisuke Kawamura
 Mode : 11n-20 Tx

Freq. [MHz]	Reading [dBm]	Cable Loss [dB]	Atten. [dB]	Result		Limit		Margin [dB]
				[dBm]	[mW]	[dBm]	[mW]	
2412	11.28	1.77	10.01	23.06	202.30	30.00	1000	6.94
2437	11.21	1.77	10.01	22.99	199.07	30.00	1000	7.01
2462	10.54	1.78	10.01	22.33	171.00	30.00	1000	7.67

Sample Calculation:

Result = Reading + Cable Loss (including the cable(s) customer supplied) + Attenuator

2437MHz

Rate [MCS]	Reading [dBm]	Remark
0	10.64	
1	11.21	*
2	10.44	
3	10.74	
4	10.51	
5	10.36	
6	10.61	
7	10.61	

*: Worst Rate

All comparison were carried out on same frequency and measurement factors.

UL Japan, Inc.

Head Office EMC Lab.

4383-326 Asama-cho, Ise-shi, Mie-ken 516-0021 JAPAN

Telephone : +81 596 24 8999

Facsimile : +81 596 24 8124

Average Output Power

Test place : Head Office EMC Lab. No.6 Measurement Room
Report No. : 10124906H
Date : 12/25/2013
Temperature/ Humidity : 20 deg.C./ 31%
Engineer : Keisuke Kawamura
Mode : 11b/g/n-20 Tx

[AV]

11b

5.5Mbps

Freq. [MHz]	Reading [dBm]	Cable Loss [dB]	Atten. [dB]	Result		Limit		Margin [dB]
				[dBm]	[mW]	[dBm]	[mW]	
2412	5.24	1.77	10.01	17.02	50.35	30.00	1000	12.98
2437	4.98	1.77	10.01	16.76	47.42	30.00	1000	13.24
2462	5.02	1.78	10.01	16.81	47.97	30.00	1000	13.19

11g

36Mbps

Freq. [MHz]	Reading [dBm]	Cable Loss [dB]	Atten. [dB]	Result		Limit		Margin [dB]
				[dBm]	[mW]	[dBm]	[mW]	
2412	1.15	1.77	10.01	12.93	19.63	30.00	1000	17.07
2437	1.04	1.77	10.01	12.82	19.14	30.00	1000	17.18
2462	0.89	1.78	10.01	12.68	18.54	30.00	1000	17.32

11n-20

MCS1

Freq. [MHz]	Reading [dBm]	Cable Loss [dB]	Atten. [dB]	Result		Limit		Margin [dB]
				[dBm]	[mW]	[dBm]	[mW]	
2412	0.16	1.77	10.01	11.94	15.63	30.00	1000	18.06
2437	0.03	1.77	10.01	11.81	15.17	30.00	1000	18.19
2462	0.01	1.78	10.01	11.80	15.14	30.00	1000	18.20

Sample Calculation:

Result = Reading + Cable Loss (including the cable(s) customer supplied) + Attenuator

UL Japan, Inc.

Head Office EMC Lab.

4383-326 Asama-cho, Ise-shi, Mie-ken 516-0021 JAPAN

Telephone : +81 596 24 8999

Facsimile : +81 596 24 8124

Radiated Spurious Emission

Test place	Head Office EMC Lab. No.2 Semi Anechoic Chamber
Report No.	10124906H
Date	01/16/2014
Temperature/ Humidity	23 deg.C./ 35%RH
Engineer	Takumi Shimada
Mode	11b Tx 2437MHz

Polarity	Frequency [MHz]	Detector	Reading [dBuV]	Ant.Fac. [dB/m]	Loss [dB]	Gain [dB]	Result [dBuV/m]	Limit [dBuV/m]	Margin [dB]	Remark
Hori	4874.000	PK	44.6	30.8	5.4	34.9	45.9	73.9	28.0	
Hori	7311.000	PK	42.1	35.7	6.6	34.9	49.5	73.9	24.4	
Hori	9748.000	PK	43.8	38.4	7.3	35.4	54.1	73.9	19.8	
Hori	4874.000	AV	34.6	30.8	5.4	34.9	35.9	53.9	18.0	
Hori	7311.000	AV	34.0	35.7	6.6	34.9	41.4	53.9	12.5	
Hori	9748.000	AV	34.9	38.4	7.3	35.4	45.2	53.9	8.7	
Vert	4874.000	PK	46.5	30.8	5.4	34.9	47.8	73.9	26.1	
Vert	7311.000	PK	42.9	35.7	6.6	34.9	50.3	73.9	23.6	
Vert	9748.000	PK	43.8	38.4	7.3	35.4	54.1	73.9	19.8	
Vert	4874.000	AV	35.9	30.8	5.4	34.9	37.2	53.9	16.7	
Vert	7311.000	AV	33.8	35.7	6.6	34.9	41.2	53.9	12.7	
Vert	9748.000	AV	35.0	38.4	7.3	35.4	45.3	53.9	8.6	

Result = Reading + Ant Factor + Loss (Cable+Attenuator+Filter-Distance factor(above 10GHz)) - Gain(Amplifier)

*Other frequency noises omitted in this report were not seen or had enough margin (more than 20dB).

Distance factor: 10GHz-26.5GHz 20log(3.0m/1.0m)= 9.5dB
 26.5GHz-40GHz 20log(3.0m/0.5m)=15.6dB

Radiated Spurious Emission

Test place : Head Office EMC Lab. No.2 Semi Anechoic Chamber
Report No. : 10124906H
Date : 01/16/2014
Temperature/ Humidity : 23 deg.C./ 35%RH
Engineer : Takumi Shimada
Mode : 11g Tx 2437MHz

Polarity	Frequency [MHz]	Detector	Reading [dBuV]	Ant.Fac. [dB/m]	Loss [dB]	Gain [dB]	Duty Factor [dB]	Result [dBuV/m]	Limit [dBuV/m]	Margin [dB]	Remark
Hori	4874.000	PK	43.3	30.8	5.4	34.9	-	44.6	73.9	29.3	
Hori	7311.000	PK	43.0	35.7	6.6	34.9	-	50.4	73.9	23.5	
Hori	9748.000	PK	44.7	38.4	7.3	35.4	-	55.0	73.9	18.9	
Hori	4874.000	AV	33.7	30.8	5.4	34.9	0.3	35.3	53.9	18.6	
Hori	7311.000	AV	33.8	35.7	6.6	34.9	0.3	41.5	53.9	12.4	
Hori	9748.000	AV	35.0	38.4	7.3	35.4	0.3	45.6	53.9	8.3	
Vert	4874.000	PK	42.6	30.8	5.4	34.9	-	43.9	73.9	30.0	
Vert	7311.000	PK	43.1	35.7	6.6	34.9	-	50.5	73.9	23.4	
Vert	9748.000	PK	44.8	38.4	7.3	35.4	-	55.1	73.9	18.8	
Vert	4874.000	AV	33.6	30.8	5.4	34.9	0.3	35.2	53.9	18.7	
Vert	7311.000	AV	33.8	35.7	6.6	34.9	0.3	41.5	53.9	12.4	
Vert	9748.000	AV	35.1	38.4	7.3	35.4	0.3	45.7	53.9	8.2	

Result = Reading + Ant Factor + Loss (Cable+Attenuator+Filter-Distance factor(above 10GHz)) - Gain(Amplifier)+Duty Factor

*Other frequency noises omitted in this report were not seen or had enough margin (more than 20dB).

Distance factor: 10GHz-26.5GHz 20log(3.0m/1.0m)= 9.5dB
 26.5GHz-40GHz 20log(3.0m/0.5m)=15.6dB

UL Japan, Inc.

Head Office EMC Lab.

4383-326 Asama-cho, Ise-shi, Mie-ken 516-0021 JAPAN

Telephone : +81 596 24 8999

Facsimile : +81 596 24 8124

Radiated Spurious Emission

Test place Head Office EMC Lab. No.2 Semi Anechoic Chamber
Report No. 10124906H
Date 01/16/2014
Temperature/ Humidity 23 deg.C./ 35%RH
Engineer Takumi Shimada
Mode 11n-20 Tx 2462MHz

Polarity	Frequency [MHz]	Detector	Reading [dBuV]	Ant.Fac. [dB/m]	Loss [dB]	Gain [dB]	Duty Factor [dB]	Result [dBuV/m]	Limit [dBuV/m]	Margin [dB]	Remark
Hori	2483.500	PK	64.6	26.7	3.1	35.7	-	58.7	73.9	15.2	
Hori	2483.500	AV	51.1	26.7	3.1	35.7	0.1	45.3	53.9	8.6	*1)
Vert	2483.500	PK	65.3	26.7	3.1	35.7	-	59.4	73.9	14.5	
Vert	2483.500	AV	50.2	26.7	3.1	35.7	0.1	44.4	53.9	9.5	*1)

Result = Reading + Ant Factor + Loss (Cable+Attenuator+Filter-Distance factor(above 10GHz)) - Gain(Amplifier)+Duty Factor

*Other frequency noises omitted in this report were not seen or had enough margin (more than 20dB).

*)1 Not out of band emission (Leakage Power)

UL Japan, Inc.

Head Office EMC Lab.

4383-326 Asama-cho, Ise-shi, Mie-ken 516-0021 JAPAN

Telephone : +81 596 24 8999

Facsimile : +81 596 24 8124

Burst rate confirmation

Test place	Head Office EMC Lab. No.6 Measurement Room
Report No.	10124906H
Date	12/25/2013
Temperature/ Humidity	20 deg.C./ 31%
Engineer	Keisuke Kawamura
Mode	11b/g/n-20 Tx

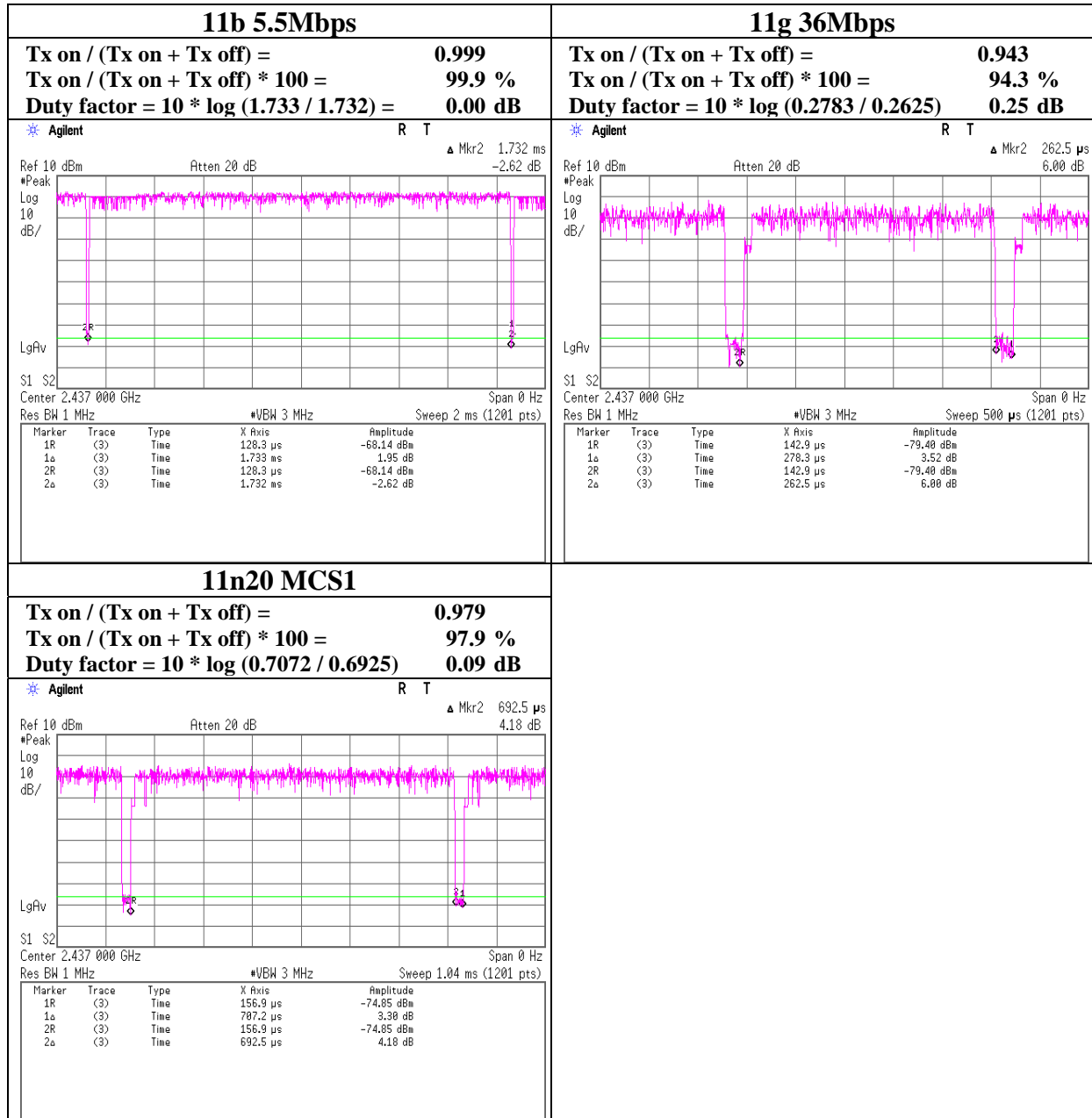

Conducted Spurious Emission

Test place	Head Office EMC Lab. No.6 Measurement Room
Report No.	10124906H
Date	12/25/2013
Temperature/ Humidity	20 deg.C./ 31%
Engineer	Keisuke Kawamura
Mode	11g Tx 2412MHz

11g Tx 2412MHz

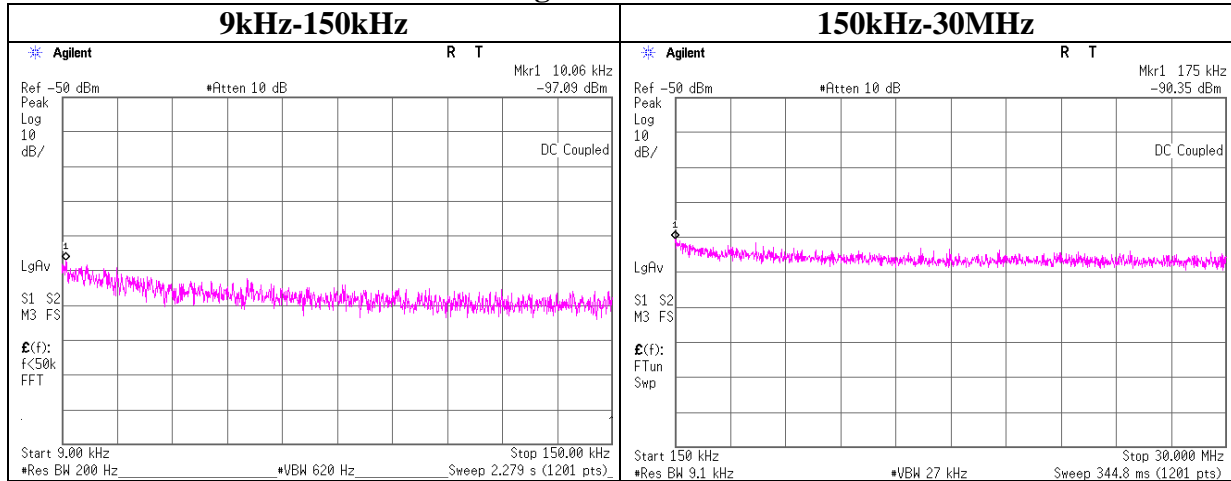

Frequency [kHz]	Reading [dBm]	Cable Loss [dB]	Attenuator [dB]	Antenna Gain [dBi]	EIRP [dBm]	Distance [m]	Ground bounce [dB]	E (field strength) [dBuV/m]	Limit [dBuV/m]
10.06	-97.1	0.01	20.0	-1.6	-78.7	300.0	6.0	-17.4	47.6
175	-90.4	0.01	20.0	-1.6	-71.9	300.0	6.0	-10.7	22.7

$E = \text{EIRP} - 20\log(D) + \text{Ground bounce} + 104.8 [\text{dBuV/m}]$

$\text{EIRP} = \text{Reading} + \text{Cable Loss} + \text{Attenuator} + \text{Antenna Gain}$

UL Japan, Inc.

Head Office EMC Lab.

4383-326 Asama-cho, Ise-shi, Mie-ken 516-0021 JAPAN

Telephone : +81 596 24 8999

Facsimile : +81 596 24 8124

Power Density

Test place Head Office EMC Lab. No.6 Measurement Room
Report No. 10124906H
Date 12/25/2013
Temperature/ Humidity 20 deg.C./ 31%
Engineer Keisuke Kawamura
Mode 11b/g/n-20 Tx

11b

Freq. [MHz]	Reading [dBm]	Cable Loss [dB]	Atten. [dB]	Result [dBm]	Limit [dBm]	Margin [dB]
2412.00	-27.58	1.77	19.96	-5.85	8.00	13.85
2437.00	-27.76	1.77	19.96	-6.03	8.00	14.03
2462.00	-28.29	1.78	19.96	-6.55	8.00	14.55

11g

Freq. [MHz]	Reading [dBm]	Cable Loss [dB]	Atten. [dB]	Result [dBm]	Limit [dBm]	Margin [dB]
2412.00	-33.27	1.77	19.96	-11.54	8.00	19.54
2437.00	-33.58	1.77	19.96	-11.85	8.00	19.85
2462.00	-32.03	1.78	19.96	-10.29	8.00	18.29

11n-20

Freq. [MHz]	Reading [dBm]	Cable Loss [dB]	Atten. [dB]	Result [dBm]	Limit [dBm]	Margin [dB]
2412.00	-35.20	1.77	19.96	-13.47	8.00	21.47
2437.00	-34.13	1.77	19.96	-12.40	8.00	20.40
2462.00	-34.76	1.78	19.96	-13.02	8.00	21.02

Sample Calculation:

Result = Reading + Cable Loss (including the cable(s) customer supplied) + Attenuator

UL Japan, Inc.

Head Office EMC Lab.

4383-326 Asama-cho, Ise-shi, Mie-ken 516-0021 JAPAN

Telephone : +81 596 24 8999

Facsimile : +81 596 24 8124

Power Density

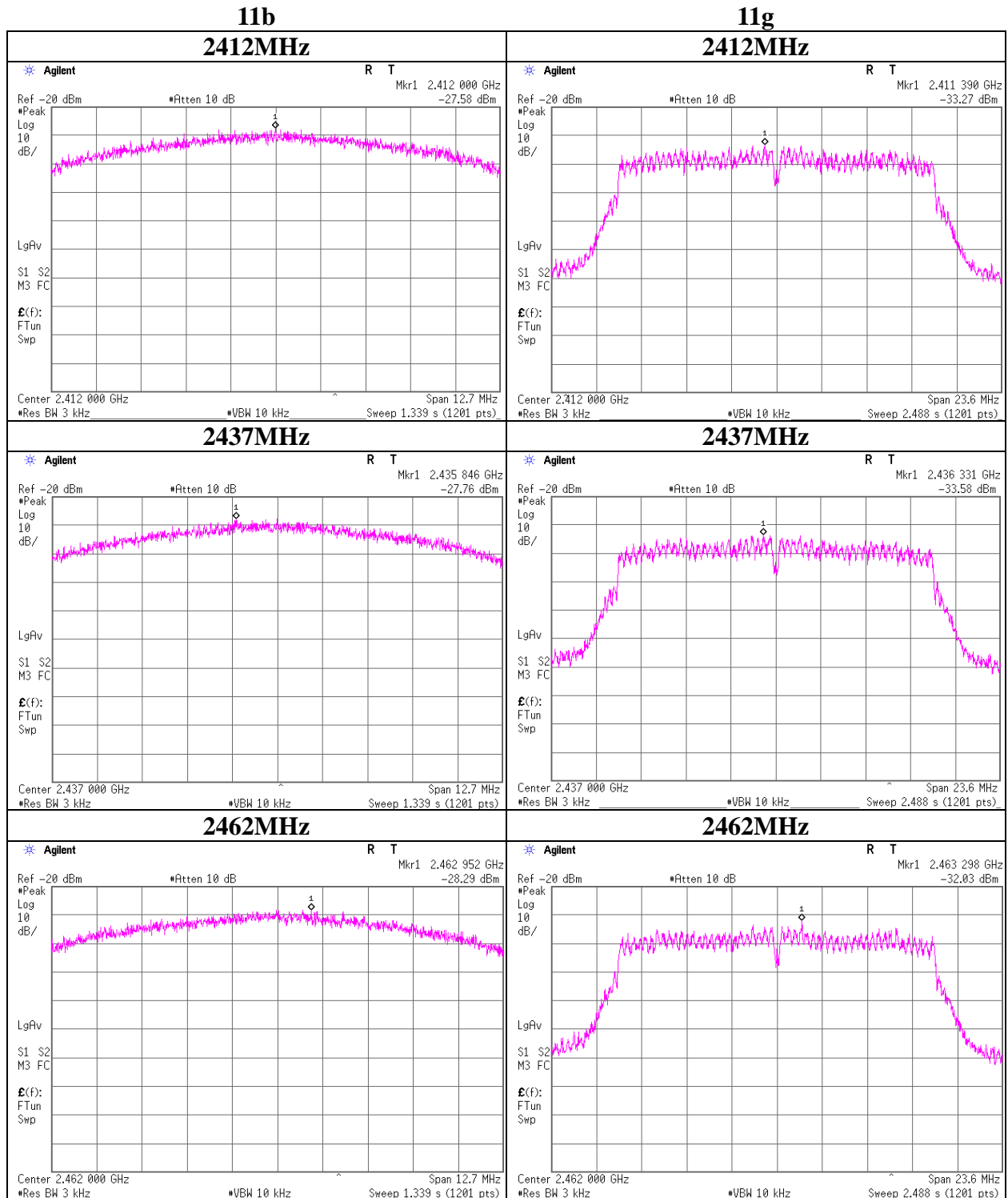

Power Density

11n-20

2412MHz

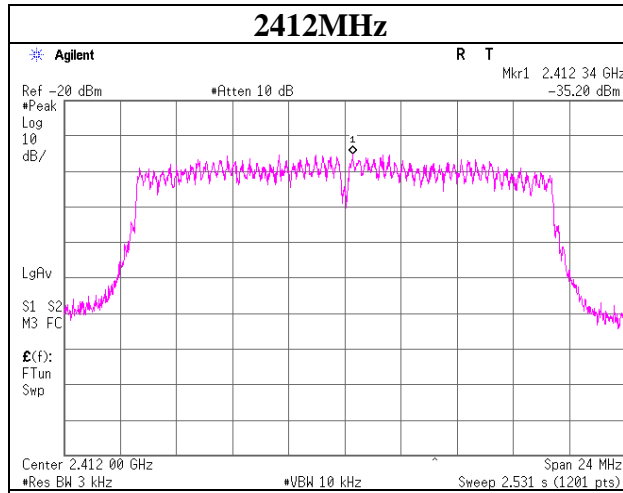

2437MHz

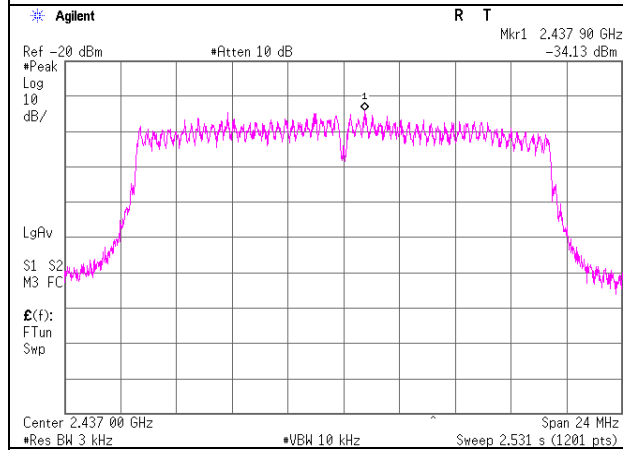

2462MHz

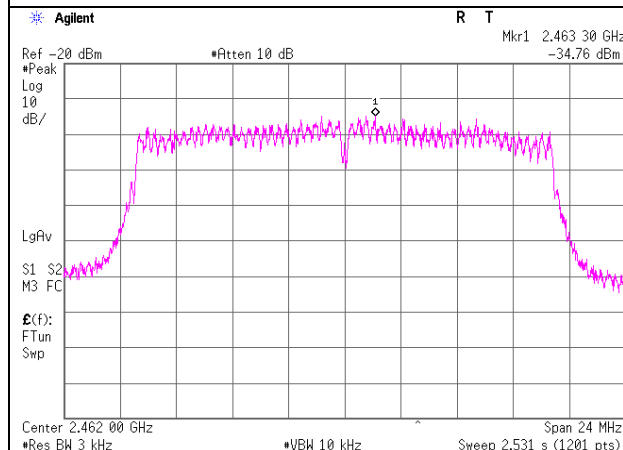

UL Japan, Inc.

Head Office EMC Lab.

4383-326 Asama-cho, Ise-shi, Mie-ken 516-0021 JAPAN

Telephone : +81 596 24 8999

Facsimile : +81 596 24 8124

99% Occupied Bandwidth

Test place	Head Office EMC Lab. No.6 Measurement Room
Report No.	10124906H
Date	12/25/2013
Temperature/ Humidity	20 deg.C./ 31%
Engineer	Keisuke Kawamura
Mode	11g Tx 2412MHz

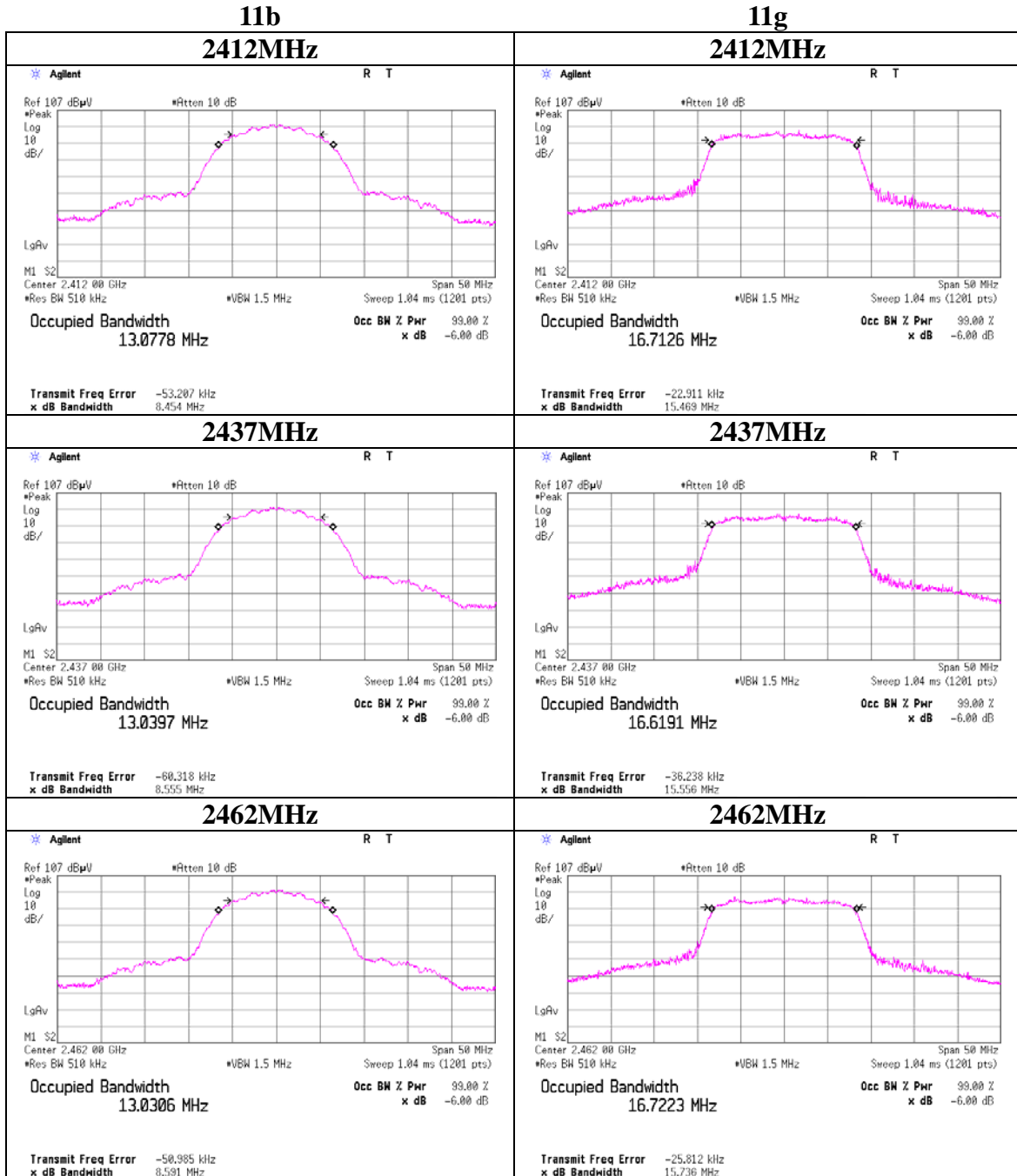

99% Occupied Bandwidth

Test place	Head Office EMC Lab. No.6 Measurement Room
Report No.	10124906H
Date	12/25/2013
Temperature/ Humidity	20 deg.C./ 31%
Engineer	Keisuke Kawamura
Mode	11g Tx 2412MHz

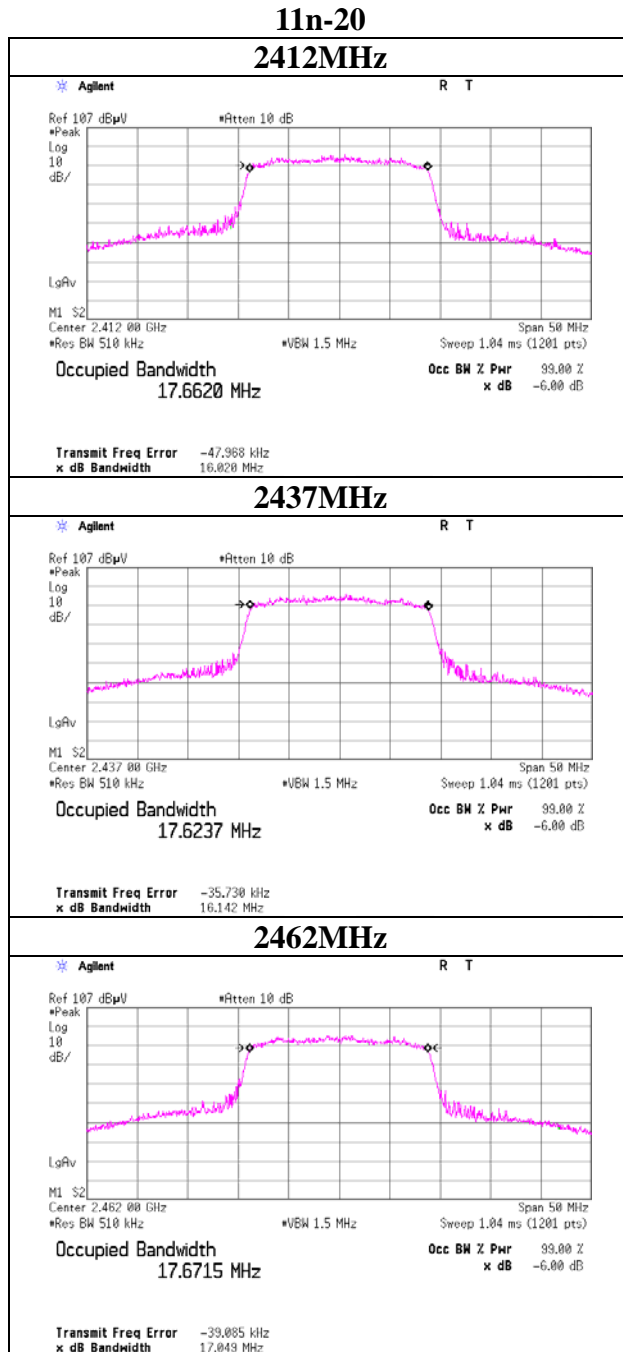

APPENDIX 2: Test instruments

EMI test equipment

Control No.	Instrument	Manufacturer	Model No	Serial No	Test Item	Calibration Date * Interval(month)
MOS-14	Thermo-Hygrometer	Custom	CTH-201	-	AT	2013/02/26 * 12
MRENT-114	Spectrum Analyzer	Agilent	E4440A	MY46187105	AT	2013/11/11 * 12
MCC-137	Microwave cable	HUBER+SUHNER	SUCOFLEX 102	37954/2	AT	2013/10/18 * 12
MAT-22	Attenuator(10dB) 1-18GHz	Orient Microwave	BX10-0476-00	-	AT	2013/03/21 * 12
MAT-21	Attenuator(20dB)(above 1GHz)	HIROSE ELECTRIC CO.,LTD.	AT-120	901247	AT	2014/01/15 * 12
MPM-13	Power Meter	Anritsu	ML2495A	0824014	AT	2013/11/15 * 12
MPSE-18	Power sensor	Anritsu	MA2411B	0738174	AT	2013/11/15 * 12
MAEC-02	Semi Anechoic Chamber(NSA)	TDK	Semi Anechoic Chamber 3m	DA-06902	RE/CE	2013/06/30 * 12
MOS-22	Thermo-Hygrometer	Custom	CTH-201	0003	RE/CE	2013/02/26 * 12
MJM-14	Measure	KOMELON	KMC-36	-	RE/CE	-
COTS-MEMI	EMI measurement program	TSJ	TEPTO-DV	-	RE/CE	-
MRENT-95	Spectrum Analyzer	Agilent	E4440A	MY46185823	RE/CE	2013/06/14 * 12
MHA-06	Horn Antenna 1-18GHz	Schwarzbeck	BBHA9120D	254	RE	2013/02/15 * 12
MPA-10	Pre Amplifier	Agilent	8449B	3008A02142	RE	2013/01/10 * 12
MHA-02	Horn Antenna 18-26.5GHz	EMCO	3160-09	1265	RE	2013/02/15 * 12
MHF-26	High Pass Filter 3.5-18.0GHz	UL Japan	HPF SELECTOR	002	RE	2013/09/01 * 12
MTR-03	Test Receiver	Rohde & Schwarz	ESCI	100300	CE	2013/06/11 * 12
MLS-06	LISN(AMN)	Schwarzbeck	NSLK8127	8127363	CE(EUT)	2013/01/07 * 12
MLS-07	LISN(AMN)	Schwarzbeck	NSLK8127	8127364	CE(AE)	2013/01/07 * 12
MTA-31	Terminator	TME	CT-01	-	CE	2013/01/21 * 12
MCC-13	Coaxial Cable	Fujikura	3D-2W(12m)/5D-2W(5m)/5D-2W(0.8m)/5D-2W(1m)	-	CE	2013/02/06 * 12
MAT-65	Attenuator(13dB)	JFW Industries, Inc.	50FP-013H2 N	-	CE	2013/01/09 * 12

The expiration date of the calibration is the end of the expired month.

All equipment is calibrated with valid calibrations. Each measurement data is traceable to the national or international standards.

As for some calibrations performed after the tested dates, those test equipment have been controlled by means of an unbroken chains of calibrations.

**Test Item: CE: Conducted Emission
RE: Radiated Emission
AT: Antenna Terminal Conducted test**

UL Japan, Inc.

Head Office EMC Lab.

4383-326 Asama-cho, Ise-shi, Mie-ken 516-0021 JAPAN

Telephone : +81 596 24 8999

Facsimile : +81 596 24 8124