



RADIO TEST REPORT

Test Report No. : 10044596H-A

Applicant : Murata Manufacturing Co., Ltd.
Type of Equipment : Communication Module
Model No. : Type XN
FCC ID : VPYLBXN604
Test regulation : FCC Part 15 Subpart C: 2013
*Radiated Spurious Emission only
Class II Permissive Change
Test Result : Complied

1. This test report shall not be reproduced in full or partial, without the written approval of UL Japan, Inc.
2. The results in this report apply only to the sample tested.
3. This sample tested is in compliance with the above regulation.
4. The test results in this report are traceable to the national or international standards.
5. This test report must not be used by the customer to claim product certification, approval, or endorsement by NVLAP, NIST, or any agency of the Federal Government.

Date of test: August 1, 2013

Representative test engineer: 
Satofumi Matsuyama
Engineer of WiSE Japan,
UL Verification Service

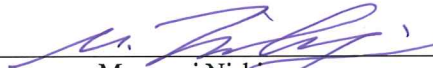
Approved by: 
Masanori Nishiyama
Manager of WiSE Japan,
UL Verification Service



NVLAP LAB CODE: 200572-0

This laboratory is accredited by the NVLAP LAB CODE 200572-0, U.S.A. The tests reported herein have been performed in accordance with its terms of accreditation.
*As for the range of Accreditation in NVLAP, you may refer to the WEB address,
<http://www.ul.com/japan/jpn/pages/services/emc/about/mark1/index.jsp#nvlap>

UL Japan, Inc.

Head Office EMC Lab.

4383-326 Asama-cho, Ise-shi, Mie-ken 516-0021 JAPAN

Telephone : +81 596 24 8999

Facsimile : +81 596 24 8124

13-EM-F0429

CONTENTS	PAGE
SECTION 1: Customer information.....	4
SECTION 2: Equipment under test (E.U.T.).....	4
SECTION 3: Test specification, procedures & results.....	5
SECTION 4: Operation of E.U.T. during testing.....	7
SECTION 5: Radiated Spurious Emission	9
APPENDIX 1: Data of EMI test.....	10
Radiated Spurious Emission	10
APPENDIX 2: Test instruments	17
APPENDIX 3: Photographs of test setup	18
Radiated Spurious Emission	18
Worst Case Position (Horizontal: X-axis/ Vertical:Y-axis).....	19
Antenna Pattern Length	20

SECTION 1: Customer information

Company Name : Murata Manufacturing Co., Ltd.
Address : 10-1, Higashikotari 1-chome, Nagaokakyo-shi, Kyoto 617-8555 Japan
Telephone Number : +81-75-955-6735
Facsimile Number : +81-75-955-6634
Contact Person : TAKAHARU KAWAKATSU

SECTION 2: Equipment under test (E.U.T.)

2.1 Identification of E.U.T.

Type of Equipment : Communication Module
Model No. : Type XN
Serial No. : Refer to Section 4, Clause 4.2
Rating : DC 3.8V
Receipt Date of Sample : July 31, 2013
Country of Mass-production : China/Japan
Condition of EUT : Engineering prototype
(Not for Sale: This sample is equivalent to mass-produced items.)
Modification of EUT : No Modification by the test lab

2.2 Product Description

General Specification

The EUT is Communication Module which is installed in Compact Digital camera.

Specification of WLAN (IEEE802.11b/g/n)

Type of radio	Wireless LAN (IEEE802.11b/g)	Wireless LAN (IEEE802.11n) 2.4G Band SISO (20M Band)
Equipment Type	Transceiver	
Frequency of Operation	2412MHz - 2462MHz	
Bandwidth & Channel spacing	Bandwidth : 20MHz Ch spacing : 5MHz	
Type of Modulation	11b: DSSS 11g: OFDM	OFDM
Antenna Type / Antenna Gain	FPC Antenna: +2.1 dBi *	
Power Supply (inner)	DC 3.8V	
Operating temperature range	-20 to +55 deg. C.	

*Radiated Emission (carrier frequency) was checked with both 3mm and 50mm of antenna pattern length, as the length has from 3mm to 50mm ranges.

Radiated Emission test in this report was performed only with FPC Antenna with 3mm length that had the worst data.

UL Japan, Inc.

Head Office EMC Lab.

4383-326 Asama-cho, Ise-shi, Mie-ken 516-0021 JAPAN

Telephone : +81 596 24 8999

Facsimile : +81 596 24 8124

SECTION 3: Test specification, procedures & results

3.1 Test Specification

Test Specification : FCC Part 15 Subpart C: 2013, final revised on June 11, 2013 and effective July 11, 2013

Title : FCC 47CFR Part15 Radio Frequency Device Subpart C Intentional Radiators
Section 15.207 Conducted limits
Section 15.247 Operation within the bands 902-928MHz,
2400-2483.5MHz, and 5725-5850MHz

3.2 Procedures and results

Item	Test Procedure	Specification	Worst margin	Results	Remarks
Spurious Emission Restricted Band Edges	FCC: "Guidance for Performing Compliance Measurements on Digital Transmission Systems (DTS) Operating Under §15.247(issued on April 9, 2013)"	FCC: Section15.247(d)	0.9dB 4824.000MHz, AV, Hori.	Complied	Radiated
	IC: RSS-Gen 4.9	IC: RSS-210 A8.5 RSS-Gen 7.2.3			

Note: UL Japan, Inc.'s EMI Work Procedures No. 13-EM-W0420 and 13-EM-W0422.

* In case any questions arise about test procedure, ANSI C63.4: 2003 is also referred.

FCC 15.31 (e)

The EUT has the power supply regulator. However one of the input voltages to RF part doesn't go through the regulator. The stable voltage will be supplied by the end product, which will be required to have a power supply regulator.

Therefore the EUT complies with the requirement.

FCC Part 15.203/212 Antenna requirement

It is impossible for end users to replace the antenna, because it is soldered on the circuit board. Therefore, the equipment complies with the antenna requirement of Section 15.203/212.

3.3 Addition to standard

No addition, exclusion nor deviation has been made from the standard.

3.4 Uncertainty

EMI

The following uncertainties have been calculated to provide a confidence level of 95% using a coverage factor k=2.

Test room (semi-anechoic chamber)	Radiated emission						
	(3m*)(+dB)				(1m*)(+dB)		(0.5m*)(+dB)
	9kHz -30MHz	30MHz -300MHz	300MHz -1GHz	1GHz -10GHz	10GHz -18GHz	18GHz -26.5GHz	26.5GHz -40GHz
No.1	4.3dB	5.0dB	5.1dB	4.9dB	5.8dB	4.4dB	4.3dB
No.2	4.3dB	5.2dB	5.1dB	5.0dB	5.7dB	4.3dB	4.2dB
No.3	4.6dB	5.0dB	5.1dB	5.0dB	5.7dB	4.5dB	4.2dB
No.4	4.8dB	5.2dB	5.0dB	5.0dB	5.7dB	5.2dB	4.2dB

*3m/1m/0.5m = Measurement distance

Radiated emission test(3m)

The data listed in this report meets the limits unless the uncertainty is taken into consideration.

UL Japan, Inc.

Head Office EMC Lab.

4383-326 Asama-cho, Ise-shi, Mie-ken 516-0021 JAPAN

Telephone : +81 596 24 8999

Facsimile : +81 596 24 8124

3.5 Test Location

UL Japan, Inc. Head Office EMC Lab. *NVLAP Lab. code: 200572-0
4383-326 Asama-cho, Ise-shi, Mie-ken 516-0021 JAPAN
Telephone : +81 596 24 8999 Facsimile : +81 596 24 8124

	FCC Registration Number	IC Registration Number	Width x Depth x Height (m)	Size of reference ground plane (m) / horizontal conducting plane	Other rooms
No.1 semi-anechoic chamber	313583	2973C-1	19.2 x 11.2 x 7.7m	7.0 x 6.0m	No.1 Power source room
No.2 semi-anechoic chamber	655103	2973C-2	7.5 x 5.8 x 5.2m	4.0 x 4.0m	-
No.3 semi-anechoic chamber	148738	2973C-3	12.0 x 8.5 x 5.9m	6.8 x 5.75m	No.3 Preparation room
No.3 shielded room	-	-	4.0 x 6.0 x 2.7m	N/A	-
No.4 semi-anechoic chamber	134570	2973C-4	12.0 x 8.5 x 5.9m	6.8 x 5.75m	No.4 Preparation room
No.4 shielded room	-	-	4.0 x 6.0 x 2.7m	N/A	-
No.5 semi-anechoic chamber	-	-	6.0 x 6.0 x 3.9m	6.0 x 6.0m	-
No.6 shielded room	-	-	4.0 x 4.5 x 2.7m	4.75 x 5.4 m	-
No.6 measurement room	-	-	4.75 x 5.4 x 3.0m	4.75 x 4.15 m	-
No.7 shielded room	-	-	4.7 x 7.5 x 2.7m	4.7 x 7.5m	-
No.8 measurement room	-	-	3.1 x 5.0 x 2.7m	N/A	-
No.9 measurement room	-	-	8.8 x 4.6 x 2.8m	2.4 x 2.4m	-
No.11 measurement room	-	-	3.1 x 3.4 x 3.0m	2.4 x 3.4m	-

* Size of vertical conducting plane (for Conducted Emission test) : 2.0 x 2.0m for No.1, No.2, No.3, and No.4 semi-anechoic chambers and No.3 and No.4 shielded rooms.

3.6 Data of EMI, Test instruments, and Test set up

Refer to APPENDIX.

UL Japan, Inc.

Head Office EMC Lab.

4383-326 Asama-cho, Ise-shi, Mie-ken 516-0021 JAPAN

Telephone : +81 596 24 8999

Facsimile : +81 596 24 8124

SECTION 4: Operation of E.U.T. during testing

4.1 Operating Mode(s)

Test operating mode was determined as follows according to “Section 1 of 6 802.11 a/b/g/n testing- Managing Complex Regulatory Approvals - ” of TCB Council Workshop October 2009.

Mode	Remarks*
IEEE 802.11b (11b)	2Mbps, PN9
IEEE 802.11n SISO 20MHz BW (11n-20)	MCS 0, PN9
*The worst condition was determined based on the test result of Maximum Peak Output Power (Mid Channel)	
*Power of the EUT was set by the software as follows; Power settings: 5dBm Software: wifitest, Version: 0.5 *This setting of software is the worst case. Any conditions under the normal use do not exceed the condition of setting. In addition, end users cannot change the settings of the output power of the product.	

*Details of Operating mode(s)

Test Item	Operating Mode	Tested frequency
Spurious Emission (Radiated)	11b Tx 11n-20 Tx *1)	2412MHz 2437MHz 2462MHz
*1) Since 11g and 11n-20 have the same modulation method and no differences in transmitting specification, test was performed on the representative mode that had the higher peak output power.		

UL Japan, Inc.

Head Office EMC Lab.

4383-326 Asama-cho, Ise-shi, Mie-ken 516-0021 JAPAN

Telephone : +81 596 24 8999

Facsimile : +81 596 24 8124

4.2 Configuration and peripherals

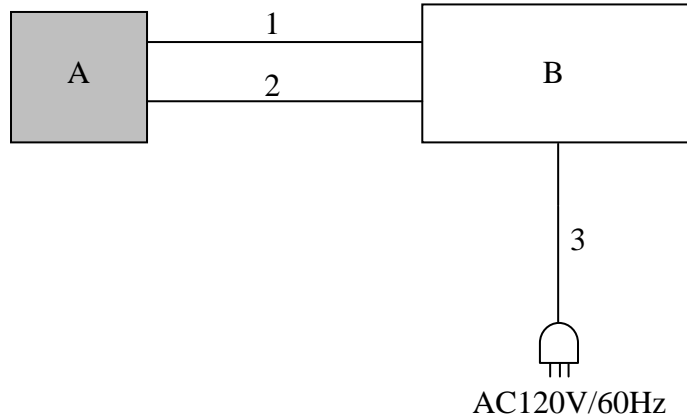

* Cabling and setup(s) were taken into consideration and test data was taken under worse case conditions.

Description of EUT and Support equipment

No.	Item	Model number	Serial number	Manufacturer	Remarks
A	Communication Module	Type XN	1	Murata Manufacturing Co., Ltd.	EUT
B	DC Power supply	PW18-1.3AT	08016530	JVC KENWOOD	-

List of cables used

No.	Name	Length (m)	Shield		Remarks
			Cable	Connector	
1	DC Cable	1.2	Unshielded	Unshielded	-
2	DC Cable	1.2	Unshielded	Unshielded	-
3	AC Cable	2.2	Unshielded	Unshielded	-

UL Japan, Inc.

Head Office EMC Lab.

4383-326 Asama-cho, Ise-shi, Mie-ken 516-0021 JAPAN

Telephone : +81 596 24 8999

Facsimile : +81 596 24 8124

SECTION 5: Radiated Spurious Emission

Test Procedure

It was measured based on "11.0 Emissions in non-restricted frequency bands" of "Guidance for Performing Compliance Measurements on Digital Transmission Systems (DTS) Operating Under §15.247 (Issued on April 9, 2013)".

EUT was placed on a urethane platform of nominal size, 0.5m by 1.0m, raised 0.8m above the conducting ground plane.

The Radiated Electric Field Strength has been measured in a Semi Anechoic Chamber with a ground plane.

The height of the measuring antenna varied between 1 and 4m and EUT was rotated a full revolution in order to obtain the maximum value of the electric field strength.

The measurements were performed for both vertical and horizontal antenna polarization with the Test Receiver, or the Spectrum Analyzer.

The measurements were made with the following detector function of the test receiver and the Spectrum analyzer (in linear mode).

The test was made with the detector (RBW/VBW) in the following table.

When using Spectrum analyzer, the test was made with adjusting span to zero by using peak hold.

Test Antennas are used as below;

Frequency	Below 30MHz	30MHz to 300MHz	300MHz to 1GHz	Above 1GHz
Antenna Type	Loop	Biconical	Logperiodic	Horn

In any 100kHz bandwidth outside the restricted band in which the spread spectrum intentional radiator is operating, the radio frequency power that is produced by the intentional radiator confirmed 20dB below that in the 100kHz bandwidth within the band that contains the highest level of the desired power, based on a radiated measurement.

20dBc was applied to the frequency over the limit of FCC 15.209 / Table 5 of RSS-Gen 7.2.5(IC) and outside the restricted band of FCC15.205 / Table 3 of RSS-Gen 7.2.2 (IC).

Frequency	Below 1GHz	Above 1GHz		20dBc
Instrument used	Test Receiver	Spectrum Analyzer		Spectrum Analyzer
Detector	QP	PK	AV *1)	PK
IF Bandwidth	BW 120kHz(T/R)	RBW: 1MHz VBW: 3MHz	Average Power Method: <u>WLAN: 12.2.5.1</u> RBW: 1MHz VBW: 3MHz Detector: Power Averaging (RMS) Trace: Free Run	RBW: 100kHz VBW: 300kHz (S/A)
Test Distance	3m	3m (below 10GHz), 1m *2) (above 10GHz)		3m (below 10GHz), 1m *2) (above 10GHz)

*1) Average Power Measurement was performed based on 6.0 & 12.2.4.1 of "Guidance for Performing Compliance Measurements on Digital Transmission Systems (DTS) Operating Under §15.247 (Issued on April 9, 2013)"

*2) Distance Factor: $20 \times \log(3.0\text{m}/1.0\text{m}) = 9.5\text{dB}$

- The carrier level and noise levels were confirmed at each position of X, Y and Z axes of EUT to see the position of maximum noise, and the test was made at the position that has the maximum noise.

The test results and limit are rounded off to one decimal place, so some differences might be observed.

Measurement range : 30M-26.5GHz
Test data : APPENDIX
Test result : Pass

UL Japan, Inc.

Head Office EMC Lab.

4383-326 Asama-cho, Ise-shi, Mie-ken 516-0021 JAPAN

Telephone : +81 596 24 8999

Facsimile : +81 596 24 8124

APPENDIX 1: Data of EMI test

Radiated Spurious Emission

Test place Head Office EMC Lab. No.4 Semi Anechoic Chamber
Report No. 10044596H
Date 08/01/2013 08/01/2013
Temperature/ Humidity 25 deg. C / 60% RH 25 deg. C / 60% RH
Engineer Satofumi Matsuyama Keisuke Kawamura
(1-10GHz) (Above 10GHz)
Mode 11b Tx 2412MHz

Polarity	Frequency [MHz]	Detector	Reading [dBuV]	Ant.Fac. [dB/m]	Loss [dB]	Gain [dB]	Duty Factor [dB]	Result [dBuV/m]	Limit [dBuV/m]	Margin [dB]	Remark
Hori	2390.000	PK	48.3	27.5	2.6	32.4	-	46.0	73.9	27.9	
Hori	4824.000	PK	51.1	31.4	4.4	31.6	-	55.3	73.9	18.6	
Hori	2390.000	AV	40.9	27.5	2.6	32.4	-	38.6	53.9	15.3	
Hori	4824.000	AV	48.8	31.4	4.4	31.6	-	53.0	53.9	0.9	
Vert	2390.000	PK	49.2	27.5	2.6	32.4	-	46.9	73.9	27.0	
Vert	4824.000	PK	50.4	31.4	4.4	31.6	-	54.6	73.9	19.3	
Vert	2390.000	AV	41.4	27.5	2.6	32.4	-	39.1	53.9	14.8	
Vert	4824.000	AV	47.1	31.4	4.4	31.6	-	51.3	53.9	2.6	

Result = Reading + Ant Factor + Loss (Cable+Attenuator+Filter-Distance factor(above 10GHz)) - Gain(Amplifier)

*Other frequency noises omitted in this report were not seen or had enough margin (more than 20dB).

*The 10th harmonic was not seen so the result was its base noise level.

Distance factor: 10GHz-26.5GHz 20log(3.0m/1.0m)= 9.5dB
26.5GHz-40GHz 20log(3.0m/0.5m)=15.6dB

20dBc Data Sheet

Polarity	Frequency [MHz]	Detector	Reading [dBuV]	Ant Factor [dB/m]	Loss [dB]	Gain [dB]	Result [dBuV/m]	Limit [dBuV/m]	Margin [dB]	Remark
Hori	2412.000	PK	97.6	27.5	2.6	32.4	95.3	-	-	Carrier
Hori	2400.000	PK	42.1	27.5	2.6	32.4	39.8	75.3	35.5	
Hori	6431.963	PK	48.8	34.8	5.1	32.1	56.6	75.3	18.7	
Vert	2412.000	PK	99.0	27.5	2.6	32.4	96.7	-	-	Carrier
Vert	2400.000	PK	45.7	27.5	2.6	32.4	43.4	76.7	33.3	
Vert	6431.958	PK	45.7	34.8	5.1	32.1	53.5	76.7	23.2	

Result = Reading + Ant Factor + Loss (Cable+Attenuator+Filter-Distance factor(above 10GHz)) - Gain(Amplifier)

UL Japan, Inc.

Head Office EMC Lab.

4383-326 Asama-cho, Ise-shi, Mie-ken 516-0021 JAPAN

Telephone : +81 596 24 8999

Facsimile : +81 596 24 8124

Radiated Spurious Emission

Test place Head Office EMC Lab. No.4 Semi Anechoic Chamber
Report No. 10044596H
Date 08/01/2013 08/01/2013
Temperature/ Humidity 25 deg. C / 60% RH 25 deg. C / 60% RH
Engineer Satofumi Matsuyama Keisuke Kawamura
(1-10GHz) (Above 10GHz)
Mode 11b Tx 2437MHz

Polarity	Frequency [MHz]	Detector	Reading [dBuV]	Ant.Fac. [dB/m]	Loss [dB]	Gain [dB]	Duty Factor [dB]	Result [dBuV/m]	Limit [dBuV/m]	Margin [dB]	Remark
Hori	4874.000	PK	51.0	31.5	4.4	31.6	-	55.3	73.9	18.6	
Hori	4874.000	AV	48.4	31.5	4.4	31.6	-	52.7	53.9	1.2	
Vert	4874.000	PK	49.2	31.5	4.4	31.6	-	53.5	73.9	20.4	
Vert	4874.000	AV	45.9	31.5	4.4	31.6	-	50.2	53.9	3.7	

Result = Reading + Ant Factor + Loss (Cable+Attenuator+Filter-Distance factor(above 10GHz)) - Gain(Amplifier)

*Other frequency noises omitted in this report were not seen or had enough margin (more than 20dB).

*The 10th harmonic was not seen so the result was its base noise level.

Distance factor: 10GHz-26.5GHz 20log(3.0m/1.0m)= 9.5dB
26.5GHz-40GHz 20log(3.0m/0.5m)=15.6dB

20dBc Data Sheet

Polarity	Frequency [MHz]	Detector	Reading [dBuV]	Ant Factor [dB/m]	Loss [dB]	Gain [dB]	Result [dBuV/m]	Limit [dBuV/m]	Margin [dB]	Remark
Hori	2437.000	PK	95.9	27.5	2.6	32.4	93.6	-	-	Carrier
Hori	6498.619	PK	48.0	35.1	5.1	32.2	56.0	73.6	17.6	
Vert	2437.000	PK	97.9	27.5	2.6	32.4	95.6	-	-	Carrier
Vert	6498.630	PK	45.3	35.1	5.1	32.2	53.3	75.6	22.3	

Result = Reading + Ant Factor + Loss (Cable+Attenuator+Filter-Distance factor(above 10GHz)) - Gain(Amplifier)

UL Japan, Inc.

Head Office EMC Lab.

4383-326 Asama-cho, Ise-shi, Mie-ken 516-0021 JAPAN

Telephone : +81 596 24 8999

Facsimile : +81 596 24 8124

Radiated Spurious Emission

Test place : Head Office EMC Lab. No.4 Semi Anechoic Chamber
Report No. : 10044596H
Date : 08/01/21013
Temperature/ Humidity : 25 deg. C / 60% RH
Engineer : Keisuke Kawamura
Mode : 11b Tx 2462MHz

Polarity	Frequency [MHz]	Detector	Reading [dBuV]	Ant.Fac. [dB/m]	Loss [dB]	Gain [dB]	Duty Factor [dB]	Result [dBuV/m]	Limit [dBuV/m]	Margin [dB]	Remark
Hori	2483.500	PK	48.6	27.5	2.7	32.4	-	46.4	73.9	27.5	
Hori	4924.000	PK	50.9	31.7	4.5	31.6	-	55.5	73.9	18.4	
Hori	2483.500	AV	36.6	27.5	2.7	32.4	-	34.4	53.9	19.5	
Hori	4924.000	AV	47.2	31.7	4.5	31.6	-	51.8	53.9	2.1	
Vert	2483.500	PK	51.4	27.5	2.7	32.4	-	49.2	73.9	24.7	
Vert	4924.000	PK	50.5	31.7	4.5	31.6	-	55.1	73.9	18.8	
Vert	2483.500	AV	41.1	27.5	2.7	32.4	-	38.9	53.9	15.0	
Vert	4924.000	AV	46.3	31.7	4.5	31.6	-	50.9	53.9	3.0	

Result = Reading + Ant Factor + Loss (Cable+Attenuator+Filter-Distance factor(above 10GHz)) - Gain(Amplifier)

*Other frequency noises omitted in this report were not seen or had enough margin (more than 20dB).

*The 10th harmonic was not seen so the result was its base noise level.

Distance factor: 10GHz-26.5GHz 20log(3.0m/1.0m)= 9.5dB
26.5GHz-40GHz 20log(3.0m/0.5m)=15.6dB

20dBc Data Sheet

Polarity	Frequency [MHz]	Detector	Reading [dBuV]	Ant Factor [dB/m]	Loss [dB]	Gain [dB]	Result [dBuV/m]	Limit [dBuV/m]	Margin [dB]	Remark
Hori	2462.000	PK	98.3	27.5	2.6	32.4	96.0	-	-	Carrier
Hori	6565.302	PK	48.0	35.2	5.2	32.2	56.2	76.0	19.8	
Vert	2462.000	PK	98.6	27.5	2.6	32.4	96.3	-	-	Carrier
Vert	6565.302	PK	44.2	35.2	5.2	32.2	52.4	76.3	23.9	

Result = Reading + Ant Factor + Loss (Cable+Attenuator+Filter-Distance factor(above 10GHz)) - Gain(Amplifier)

UL Japan, Inc.

Head Office EMC Lab.

4383-326 Asama-cho, Ise-shi, Mie-ken 516-0021 JAPAN

Telephone : +81 596 24 8999

Facsimile : +81 596 24 8124

Radiated Spurious Emission

Test place Head Office EMC Lab. No.4 Semi Anechoic Chamber
Report No. 10044596H
Date 08/01/21013
Temperature/ Humidity 25 deg. C / 60% RH
Engineer Keisuke Kawamura
Mode 11n-20 Tx 2437MHz

Polarity	Frequency [MHz]	Detector	Reading [dBuV]	Ant.Fac. [dB/m]	Loss [dB]	Gain [dB]	Duty Factor [dB]	Result [dBuV/m]	Limit [dBuV/m]	Margin [dB]	Remark
Hori	4874.000	PK	50.6	31.5	4.4	31.6	-	54.9	73.9	19.1	
Hori	7311.000	PK	41.7	35.8	5.3	32.7	-	50.1	73.9	23.8	
Hori	4874.000	AV	46.9	31.5	4.4	31.6	-	51.2	53.9	2.7	
Hori	7311.000	AV	32.3	35.8	5.3	32.7	-	40.7	53.9	13.2	
Vert	4874.000	PK	48.8	31.5	4.4	31.6	-	53.1	73.9	20.8	
Vert	7311.000	PK	42.1	35.8	5.3	32.7	-	50.5	73.9	23.4	
Vert	4874.000	AV	44.8	31.5	4.4	31.6	-	49.1	53.9	4.8	
Vert	7311.000	AV	32.5	35.8	5.3	32.7	-	40.9	53.9	13.0	

Result = Reading + Ant Factor + Loss (Cable+Attenuator+Filter-Distance factor(above 10GHz)) - Gain(Amplifier)

*Other frequency noises omitted in this report were not seen or had enough margin (more than 20dB).

*The 10th harmonic was not seen so the result was its base noise level.

Distance factor: 10GHz-26.5GHz 20log(3.0m/1.0m)= 9.5dB
26.5GHz-40GHz 20log(3.0m/0.5m)=15.6dB

20dBc Data Sheet

Polarity	Frequency [MHz]	Detector	Reading [dBuV]	Ant Factor [dB/m]	Loss [dB]	Gain [dB]	Result [dBuV/m]	Limit [dBuV/m]	Margin [dB]	Remark
Hori	2437.000	PK	95.5	27.5	2.6	32.4	93.2	-	-	Carrier
Hori	6498.634	PK	47.7	35.1	5.1	32.2	55.7	73.2	17.5	
Vert	2437.000	PK	96.1	27.5	2.6	32.4	93.8	-	-	Carrier
Vert	6498.634	PK	44.8	35.1	5.1	32.2	52.8	73.8	21.0	

Result = Reading + Ant Factor + Loss (Cable+Attenuator+Filter-Distance factor(above 10GHz)) - Gain(Amplifier)

UL Japan, Inc.

Head Office EMC Lab.

4383-326 Asama-cho, Ise-shi, Mie-ken 516-0021 JAPAN

Telephone : +81 596 24 8999

Facsimile : +81 596 24 8124

Burst rate confirmation

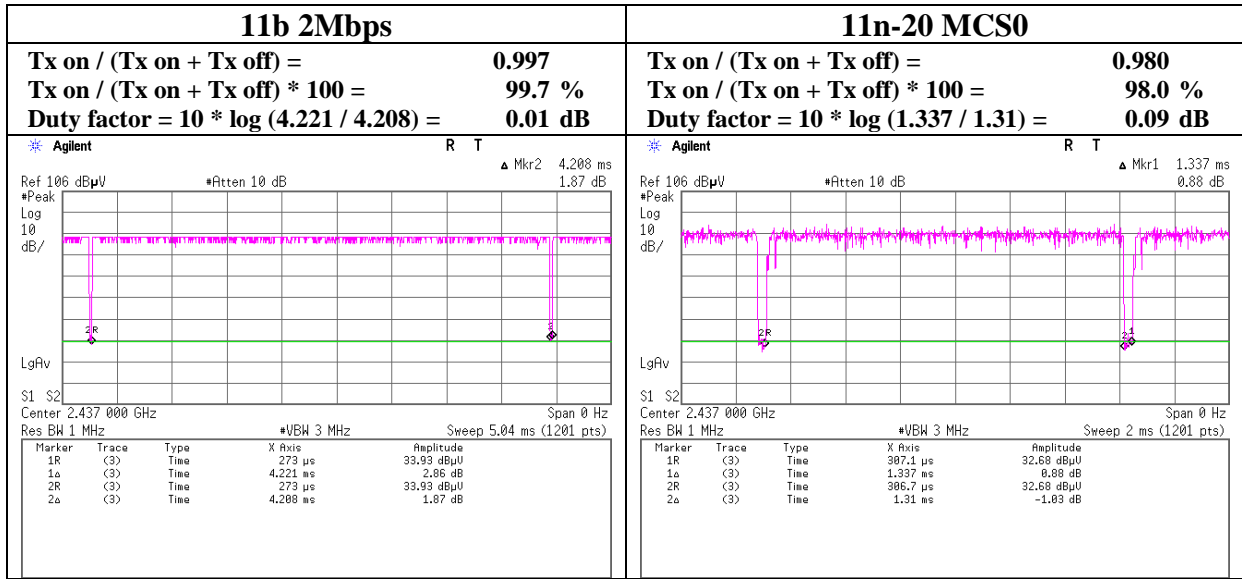

UL Japan, Inc.

Head Office EMC Lab.

4383-326 Asama-cho, Ise-shi, Mie-ken 516-0021 JAPAN

Telephone : +81 596 24 8999

Facsimile : +81 596 24 8124

APPENDIX 2: Test instruments

EMI test equipment

Control No.	Instrument	Manufacturer	Model No	Serial No	Test Item	Calibration Date * Interval(month)
MAEC-04	Semi Anechoic Chamber(NSA)	TDK	Semi Anechoic Chamber 3m	DA-10005	RE	2013/02/28 * 12
MOS-15	Thermo-Hygrometer	Custom	CTH-180	-	RE	2013/02/26 * 12
MJM-09	Measure	KDS	E19-55	-	RE	-
COTS-MEMI	EMI measurement program	TSJ	TEPTO-DV	-	RE	-
MSA-10	Spectrum Analyzer	Agilent	E4448A	MY46180655	RE	2013/02/22 * 12
MHA-21	Horn Antenna 1-18GHz	Schwarzbeck	BBHA9120D	9120D-557	RE	2012/08/17 * 12
MCC-141	Microwave Cable	Junkosha	MWX221	1305S002R(1m) / 1204S062(5m)	RE	2013/05/28 * 12
MPA-12	MicroWave System Amplifier	Agilent	83017A	MY39500780	RE	2013/03/19 * 12
MHF-06	High Pass Filter 3.5-24GHz	TOKIMEC	TF323DCA	601	RE	2013/05/30 * 12
MTR-07	Test Receiver	Rohde & Schwarz	ESCI	100635	RE	2013/04/10 * 12
MBA-05	Biconical Antenna	Schwarzbeck	BBA9106	1302	RE	2012/11/18 * 12
MLA-08	Logperiodic Antenna	Schwarzbeck	UKLP9140-A	N/A	RE	2012/11/18 * 12
MCC-50	Coaxial Cable	UL Japan	-	-	RE	2013/06/18 * 12
MAT-68	Attenuator	Anritsu	MP721B	6200961025	RE	2012/11/21 * 12
MPA-14	Pre Amplifier	SONOMA INSTRUMENT	310	260833	RE	2013/03/12 * 12
MHA-17	Horn Antenna 15-40GHz	Schwarzbeck	BBHA9170	BBHA9170307	RE	2013/06/30 * 12

The expiration date of the calibration is the end of the expired month.

All equipment is calibrated with valid calibrations. Each measurement data is traceable to the national or international standards.

As for some calibrations performed after the tested dates, those test equipment have been controlled by means of an unbroken chains of calibrations.

Test Item: RE: Radiated Emission test

UL Japan, Inc.

Head Office EMC Lab.

4383-326 Asama-cho, Ise-shi, Mie-ken 516-0021 JAPAN

Telephone : +81 596 24 8999

Facsimile : +81 596 24 8124