



RADIO TEST REPORT

Test Report No. : 10003724H-A-R1

Applicant : Murata Manufacturing Co., Ltd.
Type of Equipment : Communication Module
Model No. : WS
FCC ID : VPYLBWS
Test regulation : FCC Part 15 Subpart C: 2012
Test Result : Complied

1. This test report shall not be reproduced in full or partial, without the written approval of UL Japan, Inc.
2. The results in this report apply only to the sample tested.
3. This sample tested is in compliance with the above regulation.
4. The test results in this report are traceable to the national or international standards.
5. This test report must not be used by the customer to claim product certification, approval, or endorsement by NVLAP, NIST, or any agency of the Federal Government.
6. This report is a revised version of 10003724H-A. 10003724H-A is replaced with this report.

Date of test: February 6 to 12, 2013

Representative test engineer:

T. Nakagawa

Tomohisa Nakagawa
Engineer of WiSE Japan,
UL Verification Service

Approved by:

M. Nishiyama

Masanori Nishiyama
Manager of WiSE Japan,
UL Verification Service



NVLAP LAB CODE: 200572-0

This laboratory is accredited by the NVLAP LAB CODE 200572-0, U.S.A. The tests reported herein have been performed in accordance with its terms of accreditation.
*As for the range of Accreditation in NVLAP, you may refer to the WEB address,
<http://www.ul.com/japan/jpn/pages/services/emc/about/mark1/index.jsp#nvlap>

UL Japan, Inc.

Head Office EMC Lab.

4383-326 Asama-cho, Ise-shi, Mie-ken 516-0021 JAPAN

Telephone : +81 596 24 8116

Facsimile : +81 596 24 8124

13-EM-F0429

CONTENTS	PAGE
SECTION 1: Customer information.....	4
SECTION 2: Equipment under test (E.U.T.).....	4
SECTION 3: Test specification, procedures & results.....	5
SECTION 4: Operation of E.U.T. during testing.....	8
SECTION 5: Conducted Emission.....	10
SECTION 6: Radiated Spurious Emission	11
SECTION 7: Antenna Terminal Conducted Tests.....	12
APPENDIX 1: Data of EMI test.....	13
Conducted Emission	13
6dB Bandwidth	15
Maximum Peak Output Power	16
Radiated Spurious Emission	17
Conducted Spurious Emission	21
Power Density	24
99% Occupied Bandwidth	26
APPENDIX 2: Test instruments	27
APPENDIX 3: Photographs of test setup	29
Conducted Emission	29
Radiated Spurious Emission	30
Worst Case Position (Horizontal: Y-axis/ Vertical:Z-axis)	31

UL Japan, Inc.

Head Office EMC Lab.

4383-326 Asama-cho, Ise-shi, Mie-ken 516-0021 JAPAN

Telephone : +81 596 24 8116

Facsimile : +81 596 24 8124

SECTION 1: Customer information

Company Name : Murata Manufacturing Co., Ltd.
Address : 10-1, Higashikotari 1-chome, Nagaokakyo-shi, Kyoto 617-8555 Japan
Telephone Number : +81-75-955-6708
Facsimile Number : +81-75-955-7098
Contact Person : Yuichi Itoh

SECTION 2: Equipment under test (E.U.T.)

2.1 Identification of E.U.T.

Type of Equipment : Communication Module
Model No. : WS
Serial No. : Refer to Clause 4.2
Rating : DC2.0V – DC3.6V (Nominal: DC3.0V)
Receipt Date of Sample : February 6, 2013
Country of Mass-production : Japan, China
Condition of EUT : Production prototype
(Not for Sale: This sample is equivalent to mass-produced items.)
Modification of EUT : No Modification by the test lab

2.2 Product Description

General Specification

Clock frequency(ies) in the system : 32MHz

Radio Specification

[Bluetooth LE(Ver. 4.0)]

Radio Type : Transceiver
Frequency of Operation : 2402-2480MHz
Modulation : GFSK
Power Supply (inner) : DC1.75V
Antenna type : Monopole Antenna
Antenna Gain : 1.8dBi

Variant model: WA

The EUT has a variant model: WA.

Difference between WS and WA are as follows:

- WS: Antenna and module are separated.
- WA: Antenna is on the PCB of the module.

They have the same circuit and performance, so the test in this report was performed only with WS as representative.

UL Japan, Inc.

Head Office EMC Lab.

4383-326 Asama-cho, Ise-shi, Mie-ken 516-0021 JAPAN

Telephone : +81 596 24 8116

Facsimile : +81 596 24 8124

SECTION 3: Test specification, procedures & results

3.1 Test Specification

Test Specification : Test specification: FCC Part 15 Subpart C: 2012, final revised on December 27, 2012 and effective January 28, 2013

Title : FCC 47CFR Part15 Radio Frequency Device Subpart C Intentional Radiators
Section 15.207 Conducted limits
Section 15.247 Operation within the bands 902-928MHz,
2400-2483.5MHz, and 5725-5850MHz

3.2 Procedures and results

Item	Test Procedure	Specification	Worst margin	Results	Remarks
Conducted Emission	FCC: ANSI C63.4:2003 7. AC powerline Conducted Emission measurements ----- IC: RSS-Gen 7.2.4	FCC: Section 15.207 ----- IC: RSS-Gen 7.2.4	QP 30.6dB, 0.15000MHz, L AV 41.8dB, 0.15000MHz/0.25295MHz, L	Complied	-
6dB Bandwidth	FCC: "Guidance for Performing Compliance Measurements on Digital Transmission Systems (DTS) Operating Under §15.247(issued on October 4, 2012)" ----- IC: RSS-Gen 4.6.2	FCC: Section 15.247(a)(2) ----- IC: RSS-210 A8.2(a)	See data	Complied	Conducted
Maximum Peak Output Power	FCC: "Guidance for Performing Compliance Measurements on Digital Transmission Systems (DTS) Operating Under §15.247(issued on October 4, 2012)" ----- IC: RSS-Gen 4.8	FCC: Section 15.247(b)(3) ----- IC: RSS-210 A8.4(4)		Complied	Conducted
Power Density	FCC: "Guidance for Performing Compliance Measurements on Digital Transmission Systems (DTS) Operating Under §15.247(issued on October 4, 2012)" ----- IC: -	FCC: Section 15.247 (e) ----- IC: RSS-210 A8.2(b)		Complied	Conducted
Spurious Emission Restricted Band Edges	FCC: "Guidance for Performing Compliance Measurements on Digital Transmission Systems (DTS) Operating Under §15.247(issued on October 4, 2012)" ----- IC: RSS-Gen 4.9	FCC: Section15.247(d) ----- IC: RSS-210 A8.5 RSS-Gen 7.2.3		2.6dB 2483.500MHz, AV, Vertical	Complied

Note: UL Japan, Inc.'s EMI Work Procedures No. 13-EM-W0420 and 13-EM-W0422.

* In case any questions arise about test procedure, ANSI C63.4: 2003 is also referred.

FCC 15.31 (e)

The RF Module has its own regulator.

The stable voltage (DC1.75V) is constantly provided to the RF Module through the regulator regardless of input voltage. Therefore, this EUT complies with the requirement.

FCC Part 15.203 Antenna requirement

It is impossible for end users to replace the antenna, because it is soldered on the circuit board. Therefore, the equipment complies with the antenna requirement of Section 15.203/212.

UL Japan, Inc.

Head Office EMC Lab.

4383-326 Asama-cho, Ise-shi, Mie-ken 516-0021 JAPAN

Telephone : +81 596 24 8116

Facsimile : +81 596 24 8124

3.3 Addition to standard

Item	Test Procedure	Specification	Worst margin	Results	Remarks
99% Occupied Bandwidth	IC: RSS-Gen 4.6.1	IC: RSS-Gen 4.6.1	N/A	-	Conducted

Other than above, no addition, exclusion nor deviation has been made from the standard.

3.4 Uncertainty

EMI

The following uncertainties have been calculated to provide a confidence level of 95% using a coverage factor k=2.

Test room (semi-anechoic chamber)	Conducted emission (+dB)
	150kHz-30MHz
No.1	3.5dB
No.2	3.6dB
No.3	3.6dB
No.4	3.6dB

Test room (semi-anechoic chamber)	Radiated emission						
	(3m*)(+dB)				(1m*)(+dB)		(0.5m*)(+dB)
	9kHz -30MHz	30MHz -300MHz	300MHz -1GHz	1GHz -10GHz	10GHz -18GHz	18GHz -26.5GHz	26.5GHz -40GHz
No.1	4.3dB	5.0dB	5.1dB	4.9dB	5.8dB	4.4dB	4.3dB
No.2	4.3dB	5.2dB	5.1dB	5.0dB	5.7dB	4.3dB	4.2dB
No.3	4.6dB	5.0dB	5.1dB	5.0dB	5.7dB	4.5dB	4.2dB
No.4	4.8dB	5.2dB	5.0dB	5.0dB	5.7dB	5.2dB	4.2dB

*3m/1m/0.5m = Measurement distance

Power meter (+dB)	
Below 1GHz	Above 1GHz
1.0dB	1.0dB

Antenna terminal conducted emission and Power density (+dB)			Antenna terminal conducted emission (+dB)		Channel power (+dB)
Below 1GHz	1GHz-3GHz	3GHz-18GHz	18GHz-26.5GHz	26.5GHz-40GHz	
1.0dB	1.1dB	2.7dB	3.2dB	3.3dB	1.5dB

Conducted Emission test

The data listed in this test report has enough margin, more than the site margin.

Radiated emission test(3m)

The data listed in this report meets the limits unless the uncertainty is taken into consideration.

UL Japan, Inc.

Head Office EMC Lab.

4383-326 Asama-cho, Ise-shi, Mie-ken 516-0021 JAPAN

Telephone : +81 596 24 8116

Facsimile : +81 596 24 8124

3.5 Test Location

UL Japan, Inc. Head Office EMC Lab. *NVLAP Lab. code: 200572-0
4383-326 Asama-cho, Ise-shi, Mie-ken 516-0021 JAPAN
Telephone : +81 596 24 8116 Facsimile : +81 596 24 8124

	FCC Registration Number	IC Registration Number	Width x Depth x Height (m)	Size of reference ground plane (m) / horizontal conducting plane	Other rooms
No.1 semi-anechoic chamber	313583	2973C-1	19.2 x 11.2 x 7.7m	7.0 x 6.0m	No.1 Power source room
No.2 semi-anechoic chamber	655103	2973C-2	7.5 x 5.8 x 5.2m	4.0 x 4.0m	-
No.3 semi-anechoic chamber	148738	2973C-3	12.0 x 8.5 x 5.9m	6.8 x 5.75m	No.3 Preparation room
No.3 shielded room	-	-	4.0 x 6.0 x 2.7m	N/A	-
No.4 semi-anechoic chamber	134570	2973C-4	12.0 x 8.5 x 5.9m	6.8 x 5.75m	No.4 Preparation room
No.4 shielded room	-	-	4.0 x 6.0 x 2.7m	N/A	-
No.5 semi-anechoic chamber	-	-	6.0 x 6.0 x 3.9m	6.0 x 6.0m	-
No.6 shielded room	-	-	4.0 x 4.5 x 2.7m	4.75 x 5.4 m	-
No.6 measurement room	-	-	4.75 x 5.4 x 3.0m	4.75 x 4.15 m	-
No.7 shielded room	-	-	4.7 x 7.5 x 2.7m	4.7 x 7.5m	-
No.8 measurement room	-	-	3.1 x 5.0 x 2.7m	N/A	-
No.9 measurement room	-	-	8.0 x 4.5 x 2.8m	2.0 x 2.0m	-
No.10 measurement room	-	-	2.6 x 2.8 x 2.5m	2.4 x 2.4m	-
No.11 measurement room	-	-	3.1 x 3.4 x 3.0m	2.4 x 3.4m	-

* Size of vertical conducting plane (for Conducted Emission test) : 2.0 x 2.0m for No.1, No.2, No.3, and No.4 semi-anechoic chambers and No.3 and No.4 shielded rooms.

3.6 Data of EMI, Test instruments, and Test set up

Refer to APPENDIX.

UL Japan, Inc.

Head Office EMC Lab.

4383-326 Asama-cho, Ise-shi, Mie-ken 516-0021 JAPAN

Telephone : +81 596 24 8116

Facsimile : +81 596 24 8124

SECTION 4: Operation of E.U.T. during testing

4.1 Operating Mode(s)

Bluetooth (BT): Transmitting (Tx), Payload: PRBS9

Mode	Remarks*
Bluetooth(BT) LE(Low Energy)	Maximum Packet Size, PN9
*EUT has the power settings by the software as follows; Power settings: Same as production model Software: ControllerHostEmulator, Version 1.0.0.0 Any conditions under the normal use do not exceed the condition of setting. In addition, end users cannot change the settings of the output power of the product.	

*Details of Operating mode(s)

Test Item	Operating Mode	Tested frequency
Conducted Emission	BT LE	2402MHz
6dB Bandwidth		2442MHz
Maximum Peak Output Power		2480MHz
Spurious Emission (Radiated/Conducted)		
Power Density		
99% Occupied Bandwidth		

UL Japan, Inc.

Head Office EMC Lab.

4383-326 Asama-cho, Ise-shi, Mie-ken 516-0021 JAPAN

Telephone : +81 596 24 8116

Facsimile : +81 596 24 8124

4.2 Configuration and peripherals

[AT]

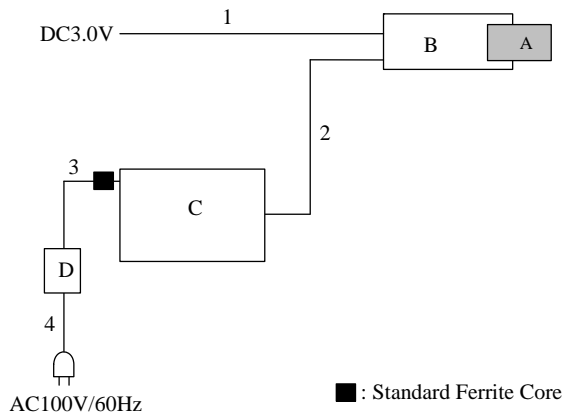

[RE/CE]

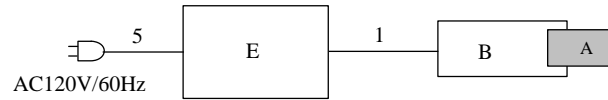

* Cabling and setup(s) were taken into consideration and test data was taken under worse case conditions.

Description of EUT and Support equipment

No.	Item	Model number	Serial number	Manufacturer	Remark
A	Communication Module	WS	LP C2 *1) A3 *2)	Murata Manufacturing Co., Ltd.	EUT
B	USB Adapter	LBCA2ZZVZE-TEMP-KIT-USBADP	-	Murata Manufacturing Co., Ltd.	-
C	Laptop PC	T60	L3-KY149 07104	Lenovo	-
D	AC Adapter	42T4418	11S42T4418Z1ZG WG29L6Y4	Lenovo	-
E	DC power supply	27014100	13441100	kikusui	-

*1) Used for Antenna Terminal Conducted Tests

*2) Used for Conducted Emission and Radiated Spurious Emission

List of cables used

No.	Name	Length (m)	Shield		Remark
			Cable	Connector	
1	DC Cable	1.4	Unshielded	Unshielded	-
2	USB Cable	1.0	Shielded	Shielded	-
3	DC Cable	1.8	Unshielded	Unshielded	-
4	AC Cable	0.9	Unshielded	Unshielded	-
5	AC Cable	1.8	Unshielded	Unshielded	-

UL Japan, Inc.

Head Office EMC Lab.

4383-326 Asama-cho, Ise-shi, Mie-ken 516-0021 JAPAN

Telephone : +81 596 24 8116

Facsimile : +81 596 24 8124

SECTION 5: Conducted Emission

Test Procedure and conditions

EUT was placed on a urethane platform of nominal size, 1.0m by 1.5m, raised 0.8m above the conducting ground plane. The rear of tabletop was located 40cm to the vertical conducting plane. The rear of EUT, including peripherals aligned and flushed with rear of tabletop. All other surfaces of tabletop were at least 80cm from any other grounded conducting surface. EUT was located 80cm from a Line Impedance Stabilization Network (LISN)/ Artificial mains Network (AMN) and excess AC cable was bundled in center.

For the tests on EUT with other peripherals (as a whole system)

I/O cables that were connected to the peripherals were bundled in center. They were folded back and forth forming a bundle 30cm to 40cm long and were hanged at a 40cm height to the ground plane. All unused 50ohm connectors of the LISN(AMN) were resistivity terminated in 50ohm when not connected to the measuring equipment.

The AC Mains Terminal Continuous disturbance Voltage has been measured with the EUT in a Semi Anechoic Chamber.

The EUT was connected to a LISN (AMN).

An overview sweep with peak detection has been performed.

The test results and limit are rounded off to one decimal place, so some differences might be observed.

Detector	: QP and AV
Measurement range	: 0.15-30MHz
Test data	: APPENDIX
Test result	: Pass

UL Japan, Inc.

Head Office EMC Lab.

4383-326 Asama-cho, Ise-shi, Mie-ken 516-0021 JAPAN

Telephone : +81 596 24 8116

Facsimile : +81 596 24 8124

SECTION 6: Radiated Spurious Emission

Test Procedure

EUT was placed on a urethane platform of nominal size, 1.0m by 1.5m, raised 0.8m above the conducting ground plane. The Radiated Electric Field Strength has been measured in a Semi Anechoic Chamber with a ground plane.

The height of the measuring antenna varied between 1 and 4m and EUT was rotated a full revolution in order to obtain the maximum value of the electric field strength.

The measurements were performed for both vertical and horizontal antenna polarization with the Test Receiver, or the Spectrum Analyzer.

The measurements were made with the following detector function of the test receiver and the Spectrum analyzer (in linear mode).

The test was made with the detector (RBW/VBW) in the following table.

When using Spectrum analyzer, the test was made with adjusting span to zero by using peak hold.

Test Antennas are used as below;

Frequency	30MHz to 300MHz	300MHz to 1GHz	Above 1GHz
Antenna Type	Biconical	Logperiodic	Horn

In any 100kHz bandwidth outside the restricted band in which the spread spectrum intentional radiator is operating, the radio frequency power that is produced by the intentional radiator confirmed 20dB below that in the 100kHz bandwidth within the band that contains the highest level of the desired power, based on a radiated measurement.

20dBc was applied to the frequency over the limit of FCC 15.209 / Table 5 of RSS-Gen 7.2.5(IC) and outside the restricted band of FCC15.205 / Table 3 of RSS-Gen 7.2.2 (IC).

Frequency	Below 1GHz	Above 1GHz		20dBc
Instrument used	Test Receiver	Spectrum Analyzer		Spectrum Analyzer
Detector	QP	PK	AV *2)	PK
IF Bandwidth	BW 120kHz(T/R)	RBW: 1MHz VBW: 3MHz	RBW: 1MHz VBW: 3MHz Trace: Free Run Detector: Power Averaging (RMS)	RBW: 100kHz VBW: 300kHz (S/A)
Test Distance	3m	3m (below 10GHz), 1m *1) (above 10GHz)		3m (below 10GHz), 1m *1) (above 10GHz)

*1) Distance Factor: $20 \times \log(3.0\text{m}/1.0\text{m}) = 9.5\text{dB}$

*2) Average Power Measurement was performed based on 8.2.1 & 10.2.3.3 of "Guidance for Performing Compliance Measurements on Digital Transmission Systems (DTS) Operating Under §15.247 (Issued on October 4, 2012)"

- The carrier level and noise levels were confirmed at each position of X, Y and Z axes of EUT to see the position of maximum noise, and the test was made at the position that has the maximum noise.

The test results and limit are rounded off to one decimal place, so some differences might be observed.

Measurement range : 30M-26.5GHz
Test data : APPENDIX
Test result : Pass

UL Japan, Inc.

Head Office EMC Lab.

4383-326 Asama-cho, Ise-shi, Mie-ken 516-0021 JAPAN

Telephone : +81 596 24 8116

Facsimile : +81 596 24 8124

SECTION 7: Antenna Terminal Conducted Tests

Test Procedure

The tests were made with below setting connected to the antenna port.

Test	Span	RBW	VBW	Sweep time	Detector	Trace	Instrument used
6dB Bandwidth	3MHz	30kHz	100kHz	Auto	Peak	Max Hold	Spectrum Analyzer
99% Occupied Bandwidth	Enough width to display 20dB Bandwidth	1 to 3% of Span	Three times of RBW	Auto	Sample	Clear Write	Spectrum Analyzer
Maximum Peak Output Power	-	-	-	Auto	Peak/Average *1)	-	Power Meter (Option 3) (Sensor: 50MHz BW)
Peak Power Density	1.5 times the 6dB bandwidth	3kHz	10kHz	Auto	Peak	Max Hold	Spectrum Analyzer *2)
Conducted Spurious Emission	9kHz to 150kHz	200Hz	620Hz	Auto	Peak	Max Hold	Spectrum Analyzer
	150kHz to 30MHz	9.1kHz	27kHz				

*1) Testing using an average detector was performed in order to confirm that the output power of the EUT met the exclusion limits stated in FCC Part 2 Section 2.1093 and FCC radio frequency (RF) Exposure Guidelines in Supplement C to OET 65 and the EUT was exempt from RF exposure SAR evaluation.
*2) PSD Option 1 of "Guidance for Performing Compliance Measurements on Digital Transmission Systems (DTS) Operating Under §15.247 (Issued on October 4, 2012)".

The test results and limit are rounded off to two decimals place, so some differences might be observed.

Test data : APPENDIX
Test result : Pass

UL Japan, Inc.

Head Office EMC Lab.

4383-326 Asama-cho, Ise-shi, Mie-ken 516-0021 JAPAN

Telephone : +81 596 24 8116

Facsimile : +81 596 24 8124

APPENDIX 1: Data of EMI test

Conducted Emission

DATA OF CONDUCTED EMISSION TEST

UL Japan, Inc. Head Office EMC Lab. No.4 Semi Anechoic Chamber
 Date : 2013/02/12

Report No. : 10003724H
 Temp./Humi. : 24deg. C / 35% RH
 Engineer : Tomohisa Nakagawa

Mode / Remarks : BT LE 2402MHz
 LIMIT : FCC15.207 QP
 FCC15.207 AV

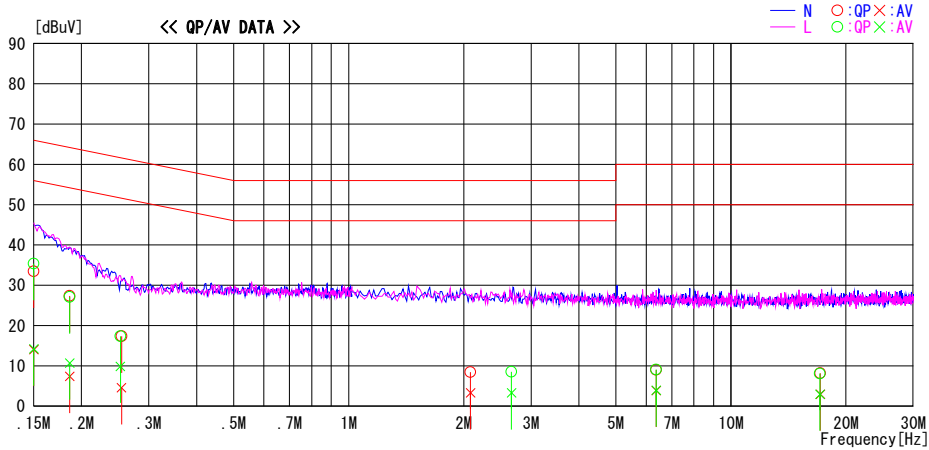

Frequency [MHz]	Reading Level		Corr. Factor [dB]	Results		Limit		Margin		Phase	Comment
	QP [dBuV]	AV [dBuV]		QP [dBuV]	AV [dBuV]	QP [dBuV]	AV [dBuV]	QP [dB]	AV [dB]		
0.15000	20.2	0.8	13.3	33.5	14.1	66.0	56.0	32.5	41.9	N	
0.18625	14.1	-5.9	13.3	27.4	7.4	64.2	54.2	36.8	46.8	N	
0.25440	4.1	-8.7	13.3	17.4	4.6	61.6	51.6	44.2	47.0	N	
2.08352	-5.1	-10.3	13.6	8.5	3.3	56.0	46.0	47.5	42.7	N	
6.37666	-5.1	-10.2	14.1	9.0	3.9	60.0	50.0	51.0	46.1	N	
17.13460	-6.6	-11.8	14.8	8.2	3.0	60.0	50.0	51.8	47.0	N	
0.15000	22.1	0.9	13.3	35.4	14.2	66.0	56.0	30.6	41.8	L	
0.18625	13.8	-2.6	13.3	27.1	10.7	64.2	54.2	37.1	43.5	L	
0.25295	4.1	-3.4	13.3	17.4	9.9	61.7	51.7	44.3	41.8	L	
2.66693	-5.0	-10.3	13.6	8.6	3.3	56.0	46.0	47.4	42.7	L	
6.37666	-5.0	-10.1	14.1	9.1	4.0	60.0	50.0	50.9	46.0	L	
17.10118	-6.7	-11.8	14.8	8.1	3.0	60.0	50.0	51.9	47.0	L	

CHART: WITH FACTOR, Peak hold data. CALCULATION: RESULT=READING+C.F.(LISN LOSS + ATTEN LOSS + CABLE LOSS)
 Except for the above table : adequate margin data below the limits.

Conducted Emission

Test place Head Office EMC Lab. No. 4 Semi Anechoic Chamber
Report No. 10003724H
Date 02/08/2013
Temperature/ Humidity 23 deg. C / 48% RH
Engineer Tomohisa Nakagawa
Mode Tx, LE

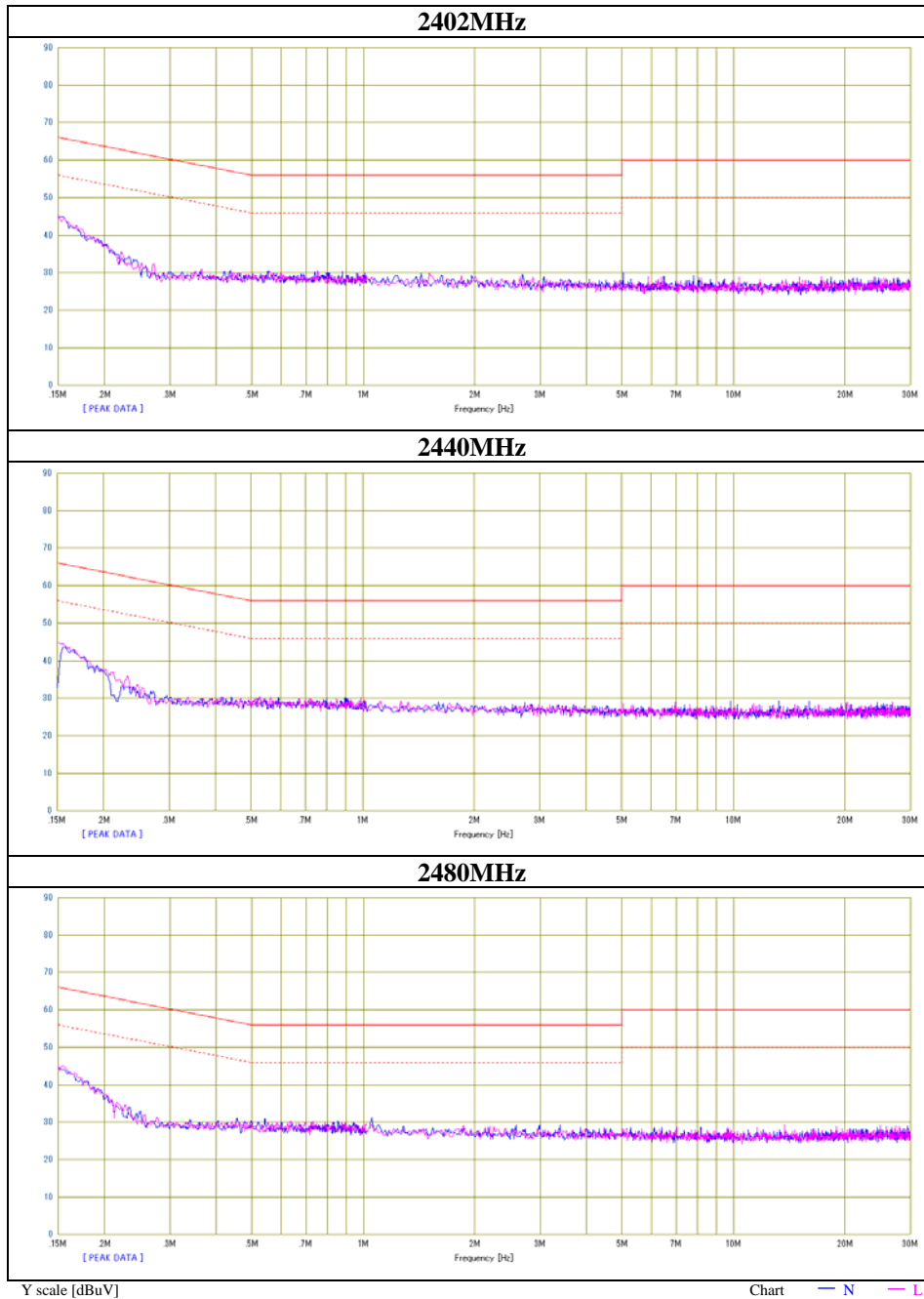

6dB Bandwidth

Test place	Head Office EMC Lab. No.7 Shielded Room
Report No.	10003724H
Date	02/06/2013
Temperature/ Humidity	24 deg. C / 35% RH
Engineer	Katsunori Okai
Mode	Tx, LE

Frequency [MHz]	6dB Bandwidth [MHz]	Limit [kHz]	
2402	0.699	>500	
2440	0.649	>500	
2480	0.639	>500	

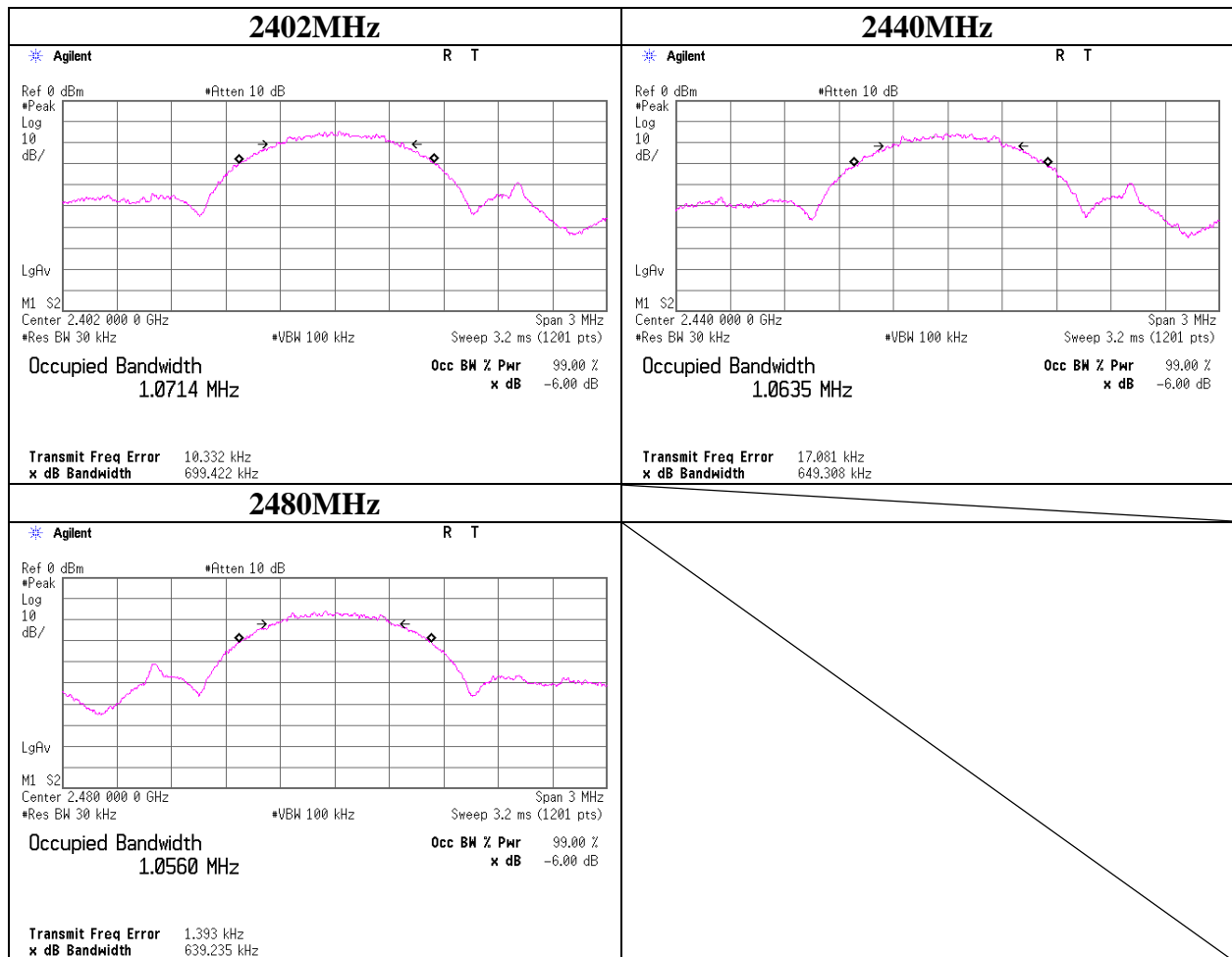

Maximum Peak Output Power

Test place Head Office EMC Lab. No.7 Shielded Room
Report No. 10003724H
Date 02/06/2013
Temperature/ Humidity 24 deg. C / 35% RH
Engineer Katsunori Okai
Mode Tx, LE

Freq. [MHz]	Reading [dBm]	Cable Loss [dB]	Atten. [dB]	Result		Limit		Margin [dB]
				[dBm]	[mW]	[dBm]	[mW]	
2402	-10.66	0.58	10.03	-0.05	0.99	30.00	1000	30.05
2440	-11.38	0.58	10.03	-0.77	0.84	30.00	1000	30.77
2480	-11.90	0.58	10.03	-1.29	0.74	30.00	1000	31.29

Sample Calculation:

Result = Reading + Cable Loss (including the cable(s) customer supplied) + Attenuator

Maximum Average Output Power (Reference data for RF EXposure)

Test place Head Office EMC Lab. No.7 Shielded Room
Report No. 10003724H
Date 02/06/2013
Temperature/ Humidity 24 deg. C / 35% RH
Engineer Katsunori Okai
Mode Tx, LE

[AV]

Freq. [MHz]	Reading [dBm]	Cable Loss [dB]	Atten. [dB]	Result		Limit		Margin [dB]
				[dBm]	[mW]	[dBm]	[mW]	
2402	-13.52	0.58	10.03	-2.91	0.51	30.00	1000	32.91
2440	-14.29	0.58	10.03	-3.68	0.43	30.00	1000	33.68
2480	-15.11	0.58	10.03	-4.50	0.35	30.00	1000	34.50

Sample Calculation:

Result = Reading + Cable Loss (including the cable(s) customer supplied) + Attenuator

UL Japan, Inc.

Head Office EMC Lab.

4383-326 Asama-cho, Ise-shi, Mie-ken 516-0021 JAPAN

Telephone : +81 596 24 8116

Facsimile : +81 596 24 8124

Radiated Spurious Emission

Test place Head Office EMC Lab. No.2 and No. 4 Semi Anechoic Chamber
Report No. 10003724H
Date 02/08/2013 02/12/2013
Temperature/ Humidity 23 deg. C / 48% RH 23 deg. C / 42% RH
Engineer Tomohisa Nakagawa Tomohisa Nakagawa
Above 1GHz Below 1GHz
Mode Tx, LE 2402MHz

Polarity	Frequency [MHz]	Detector	Reading [dBuV]	Ant.Fac. [dB/m]	Loss [dB]	Gain [dB]	Result [dBuV/m]	Limit [dBuV/m]	Margin [dB]	Remark
Hori	50.000	QP	22.7	11.3	7.4	32.1	9.3	40.0	30.7	
Hori	100.000	QP	22.5	10.6	8.1	32.1	9.1	43.5	34.4	
Hori	200.000	QP	22.0	17.0	9.0	31.9	16.1	43.5	27.4	
Hori	400.000	QP	21.7	17.8	10.5	32.0	18.0	46.0	28.0	
Hori	500.000	QP	22.0	19.1	11.1	31.9	20.3	46.0	25.7	
Hori	600.000	QP	22.2	19.9	11.6	32.1	21.6	46.0	24.4	
Hori	2390.000	PK	52.6	27.4	2.4	35.7	46.7	73.9	27.2	
Hori	4804.000	PK	46.7	31.2	4.2	34.9	47.2	73.9	26.7	
Hori	7206.000	PK	49.2	35.9	4.9	34.9	55.1	73.9	18.8	
Hori	9608.000	PK	44.7	38.8	5.7	35.4	53.8	73.9	20.1	
Hori	2390.000	AV	45.0	27.4	2.4	35.7	39.1	53.9	14.8	
Hori	4804.000	AV	40.3	31.2	4.2	34.9	40.8	53.9	13.1	
Hori	7206.000	AV	42.4	35.9	4.9	34.9	48.3	53.9	5.6	
Hori	9608.000	AV	34.6	38.8	5.7	35.4	43.7	53.9	10.2	
Vert	50.000	QP	22.7	11.3	7.4	32.1	9.3	40.0	30.7	
Vert	100.000	QP	22.5	10.6	8.1	32.1	9.1	43.5	34.4	
Vert	200.000	QP	22.0	17.0	9.0	31.9	16.1	43.5	27.4	
Vert	400.000	QP	21.7	17.8	10.5	32.0	18.0	46.0	28.0	
Vert	500.000	QP	22.0	19.1	11.1	31.9	20.3	46.0	25.7	
Vert	600.000	QP	22.2	19.9	11.6	32.1	21.6	46.0	24.4	
Vert	2390.000	PK	53.1	27.4	2.4	35.7	47.2	73.9	26.7	
Vert	4804.000	PK	45.6	31.2	4.2	34.9	46.1	73.9	27.8	
Vert	7206.000	PK	47.6	35.9	4.9	34.9	53.5	73.9	20.4	
Vert	9608.000	PK	43.9	38.8	5.7	35.4	53.0	73.9	20.9	
Vert	2390.000	AV	46.1	27.4	2.4	35.7	40.2	53.9	13.7	
Vert	4804.000	AV	37.1	31.2	4.2	34.9	37.6	53.9	16.3	
Vert	7206.000	AV	40.1	35.9	4.9	34.9	46.0	53.9	7.9	
Vert	9608.000	AV	35.4	38.8	5.7	35.4	44.5	53.9	9.4	

20dBc Data Sheet

Polarity	Frequency [MHz]	Detector	Reading [dBuV]	Ant Factor [dB/m]	Loss [dB]	Gain [dB]	Result [dBuV/m]	Limit [dBuV/m]	Margin [dB]	Remark
Hori	2402.000	PK	102.8	27.5	2.4	35.7	97.0	-	-	Carrier
Hori	2400.000	PK	67.3	27.5	2.4	35.7	61.5	77.0	15.5	
Vert	2402.000	PK	102.5	27.5	2.4	35.7	96.7	-	-	Carrier
Vert	2400.000	PK	67.7	27.5	2.4	35.7	61.9	76.7	14.8	

Result = Reading + Ant Factor + Loss (Cable+Attenuator+Filter-Distance factor(above 10GHz)) - Gain(Amplifier)

*Other frequency noises omitted in this report were not seen or had enough margin (more than 20dB).

UL Japan, Inc.

Head Office EMC Lab.

4383-326 Asama-cho, Ise-shi, Mie-ken 516-0021 JAPAN

Telephone : +81 596 24 8116

Facsimile : +81 596 24 8124

Radiated Spurious Emission

Test place Head Office EMC Lab. No.2 and No. 4 Semi Anechoic Chamber
Report No. 10003724H
Date 02/08/2013 02/12/2013
Temperature/ Humidity 23 deg. C / 48% RH 23 deg. C / 42% RH
Engineer Tomohisa Nakagawa Tomohisa Nakagawa
Above 1GHz Below 1GHz
Mode Tx, LE 2440MHz

Polarity	Frequency [MHz]	Detector	Reading [dBuV]	Ant.Fac. [dB/m]	Loss [dB]	Gain [dB]	Result [dBuV/m]	Limit [dBuV/m]	Margin [dB]	Remark
Hori	50.000	QP	22.8	11.3	7.4	32.1	9.4	40.0	30.6	
Hori	100.000	QP	22.5	10.6	8.1	32.1	9.1	43.5	34.4	
Hori	200.000	QP	22.1	17.0	9.0	31.9	16.2	43.5	27.3	
Hori	400.000	QP	21.7	17.8	10.5	32.0	18.0	46.0	28.0	
Hori	500.000	QP	22.0	19.1	11.1	31.9	20.3	46.0	25.7	
Hori	600.000	QP	22.3	19.9	11.6	32.1	21.7	46.0	24.3	
Hori	4880.000	PK	46.3	31.4	4.2	34.9	47.0	73.9	26.9	
Hori	7320.000	PK	44.4	36.0	4.9	34.9	50.4	73.9	23.5	
Hori	9760.000	PK	41.9	38.9	5.7	35.4	51.1	73.9	22.8	
Hori	4880.000	AV	41.3	31.4	4.2	34.9	42.0	53.9	11.9	
Hori	7320.000	AV	36.3	36.0	4.9	34.9	42.3	53.9	11.6	
Hori	9760.000	AV	35.1	38.9	5.7	35.4	44.3	53.9	9.6	
Vert	50.000	QP	22.7	11.3	7.4	32.1	9.3	40.0	30.7	
Vert	100.000	QP	22.5	10.6	8.1	32.1	9.1	43.5	34.4	
Vert	200.000	QP	22.1	17.0	9.0	31.9	16.2	43.5	27.3	
Vert	400.000	QP	21.7	17.8	10.5	32.0	18.0	46.0	28.0	
Vert	500.000	QP	22.0	19.1	11.1	31.9	20.3	46.0	25.7	
Vert	600.000	QP	22.3	19.9	11.6	32.1	21.7	46.0	24.3	
Vert	4880.000	PK	43.1	31.4	4.2	34.9	43.8	73.9	30.1	
Vert	7320.000	PK	44.8	36.0	4.9	34.9	50.8	73.9	23.1	
Vert	9760.000	PK	42.8	38.9	5.7	35.4	52.0	73.9	21.9	
Vert	4880.000	AV	37.6	31.4	4.2	34.9	38.3	53.9	15.6	
Vert	7320.000	AV	36.8	36.0	4.9	34.9	42.8	53.9	11.1	
Vert	9760.000	AV	35.0	38.9	5.7	35.4	44.2	53.9	9.7	

Result = Reading + Ant Factor + Loss (Cable+Attenuator+Filter-Distance factor(above 10GHz)) - Gain(Amplifier)

*Other frequency noises omitted in this report were not seen or had enough margin (more than 20dB).

*The 10th harmonic was not seen so the result was its base noise level.

Distance factor: 10GHz-26.5GHz 20log(3.0m/1.0m)= 9.5dB
26.5GHz-40GHz 20log(3.0m/0.5m)=15.6dB

UL Japan, Inc.

Head Office EMC Lab.

4383-326 Asama-cho, Ise-shi, Mie-ken 516-0021 JAPAN

Telephone : +81 596 24 8116

Facsimile : +81 596 24 8124

Radiated Spurious Emission

Test place Head Office EMC Lab. No.2 and No. 4 Semi Anechoic Chamber
Report No. 10003724H
Date 02/08/2013 02/12/2013
Temperature/ Humidity 23 deg. C / 48% RH 23 deg. C / 42% RH
Engineer Tomohisa Nakagawa Tomohisa Nakagawa
Above 1GHz Below 1GHz
Mode Tx, LE 2480MHz

Polarity	Frequency [MHz]	Detector	Reading [dBuV]	Ant.Fac. [dB/m]	Loss [dB]	Gain [dB]	Result [dBuV/m]	Limit [dBuV/m]	Margin [dB]	Remark
Hori	50.000	QP	22.9	11.3	7.4	32.1	9.5	40.0	30.5	
Hori	100.000	QP	22.5	10.6	8.1	32.1	9.1	43.5	34.4	
Hori	200.000	QP	22.1	17.0	9.0	31.9	16.2	43.5	27.3	
Hori	400.000	QP	21.7	17.8	10.5	32.0	18.0	46.0	28.0	
Hori	500.000	QP	21.9	19.1	11.1	31.9	20.2	46.0	25.8	
Hori	600.000	QP	22.1	19.9	11.6	32.1	21.5	46.0	24.5	
Hori	2483.500	PK	56.8	27.5	2.4	35.7	51.0	73.9	22.9	
Hori	4960.000	PK	47.1	31.6	4.2	34.9	48.0	73.9	25.9	
Hori	7440.000	PK	44.7	36.2	5.0	34.9	51.0	73.9	22.9	
Hori	9920.000	PK	44.8	39.1	5.8	35.4	54.3	73.9	19.6	
Hori	2483.500	AV	56.9	27.5	2.4	35.7	51.1	53.9	2.8	
Hori	4960.000	AV	39.3	31.6	4.2	34.9	40.2	53.9	13.7	
Hori	7440.000	AV	34.2	36.2	5.0	34.9	40.5	53.9	13.4	
Hori	9920.000	AV	34.2	39.1	5.8	35.4	43.7	53.9	10.2	
Vert	50.000	QP	22.7	11.3	7.4	32.1	9.3	40.0	30.7	
Vert	100.000	QP	22.5	10.6	8.1	32.1	9.1	43.5	34.4	
Vert	200.000	QP	22.1	17.0	9.0	31.9	16.2	43.5	27.3	
Vert	400.000	QP	21.7	17.8	10.5	32.0	18.0	46.0	28.0	
Vert	500.000	QP	22.0	19.1	11.1	31.9	20.3	46.0	25.7	
Vert	600.000	QP	22.3	19.9	11.6	32.1	21.7	46.0	24.3	
Vert	2483.500	PK	61.1	27.5	2.4	35.7	55.3	73.9	18.6	
Vert	4960.000	PK	46.1	31.6	4.2	34.9	47.0	73.9	26.9	
Vert	7440.000	PK	44.4	36.2	5.0	34.9	50.7	73.9	23.2	
Vert	9920.000	PK	44.2	39.1	5.8	35.4	53.7	73.9	20.2	
Vert	2483.500	AV	57.1	27.5	2.4	35.7	51.3	53.9	2.6	
Vert	4960.000	AV	37.3	31.6	4.2	34.9	38.2	53.9	15.7	
Vert	7440.000	AV	34.3	36.2	5.0	34.9	40.6	53.9	13.3	
Vert	9920.000	AV	34.4	39.1	5.8	35.4	43.9	53.9	10.0	

Result = Reading + Ant Factor + Loss (Cable+Attenuator+Filter-Distance factor(above 10GHz)) - Gain(Amplifier)

*Other frequency noises omitted in this report were not seen or had enough margin (more than 20dB).

*The 10th harmonic was not seen so the result was its base noise level.

Distance factor: 10GHz-26.5GHz 20log(3.0m/1.0m)= 9.5dB
26.5GHz-40GHz 20log(3.0m/0.5m)=15.6dB

UL Japan, Inc.

Head Office EMC Lab.

4383-326 Asama-cho, Ise-shi, Mie-ken 516-0021 JAPAN

Telephone : +81 596 24 8116

Facsimile : +81 596 24 8124

Duty rate confirmation

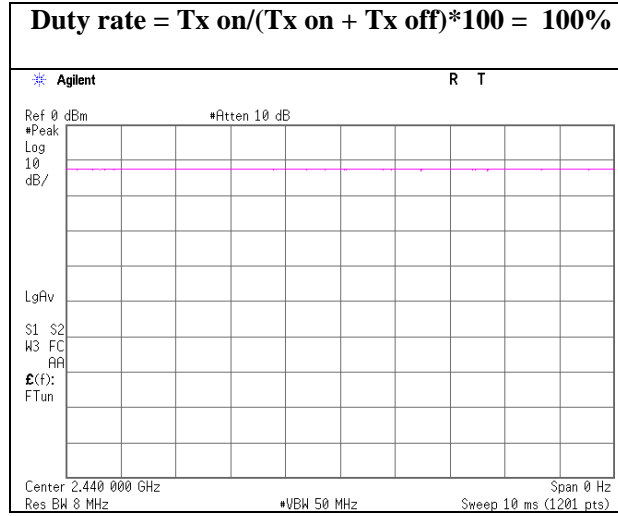

UL Japan, Inc.

Head Office EMC Lab.

4383-326 Asama-cho, Ise-shi, Mie-ken 516-0021 JAPAN

Telephone : +81 596 24 8116

Facsimile : +81 596 24 8124

Conducted Spurious Emission

Tx 2402MHz

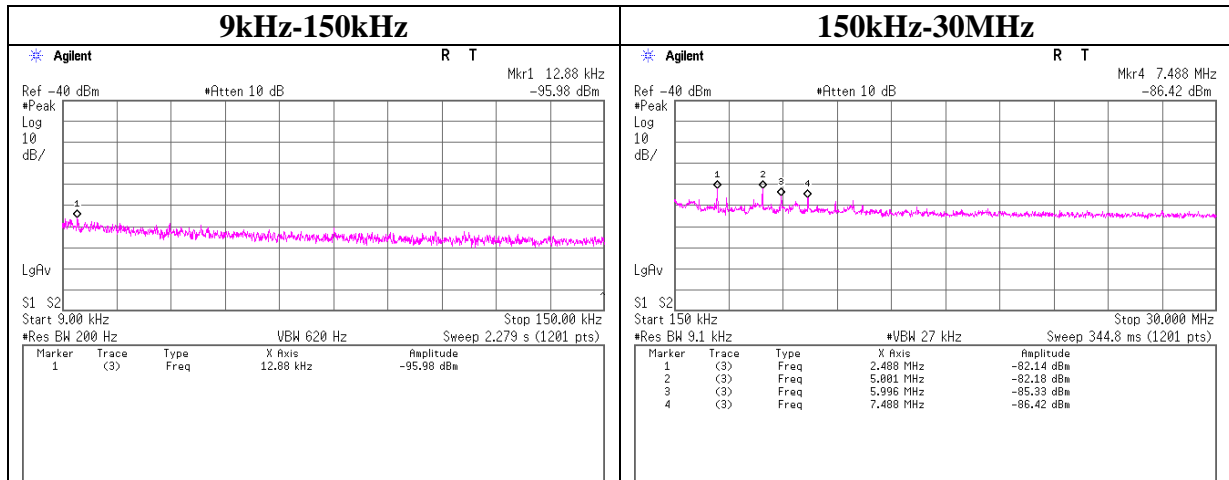

Frequency [kHz]	Reading [dBm]	Cable Loss [dB]	Attenuator [dB]	Antenna Gain [dBi]	EIRP [dBm]	Distance [m]	Ground bounce [dB]	E (field strength) [dBuV/m]	Limit [dBuV/m]
12.88	-96.0	0.6	9.9	2.0	-83.5	300.0	6.0	-22.3	45.4
2488	-82.1	0.6	9.8	2.0	-69.7	30.0	6.0	11.6	29.5
5001	-82.2	0.6	9.8	2.0	-69.7	30.0	6.0	11.6	29.5
5996	-85.3	0.6	9.8	2.0	-72.9	30.0	6.0	8.4	29.5
7488	-86.4	0.7	9.8	2.0	-73.9	30.0	6.0	7.3	29.5

$E = \text{EIRP} - 20\log(D) + \text{Ground bounce} + 104.8 [\text{dBuV/m}]$

$\text{EIRP} = \text{Reading} + \text{Cable Loss} + \text{Attenuator} + \text{Antenna Gain}$

UL Japan, Inc.

Head Office EMC Lab.

4383-326 Asama-cho, Ise-shi, Mie-ken 516-0021 JAPAN

Telephone : +81 596 24 8116

Facsimile : +81 596 24 8124

Conducted Spurious Emission

Tx 2440MHz

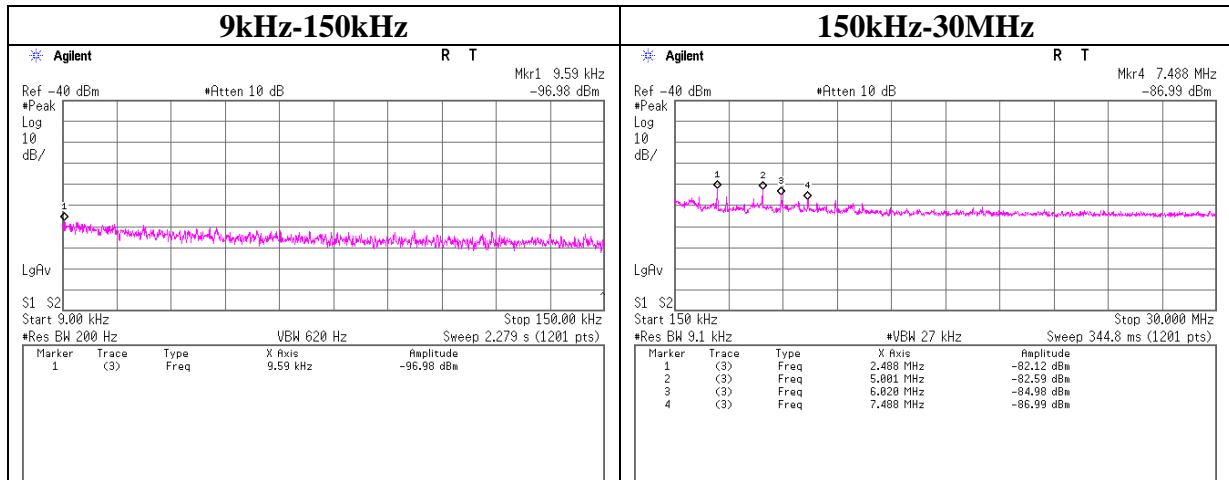

Frequency [kHz]	Reading [dBm]	Cable Loss [dB]	Attenuator [dB]	Antenna Gain [dBi]	EIRP [dBm]	Distance [m]	Ground bounce [dB]	E (field strength) [dBuV/m]	Limit [dBuV/m]
9.59	-97.0	0.6	9.9	2.0	-84.5	300.0	6.0	-23.3	48.0
2488	-82.1	0.6	9.8	2.0	-69.7	30.0	6.0	11.6	29.5
5001	-82.6	0.6	9.8	2.0	-70.1	30.0	6.0	11.1	29.5
6020	-85.0	0.6	9.8	2.0	-72.5	30.0	6.0	8.8	29.5
7488	-87.0	0.7	9.8	2.0	-74.5	30.0	6.0	6.8	29.5

$E = \text{EIRP} - 20\log(D) + \text{Ground bounce} + 104.8 [\text{dBuV/m}]$
 $\text{EIRP} = \text{Reading} + \text{Cable Loss} + \text{Attenuator} + \text{Antenna Gain}$

UL Japan, Inc.

Head Office EMC Lab.

4383-326 Asama-cho, Ise-shi, Mie-ken 516-0021 JAPAN

Telephone : +81 596 24 8116

Facsimile : +81 596 24 8124

Conducted Spurious Emission

Tx 2480MHz

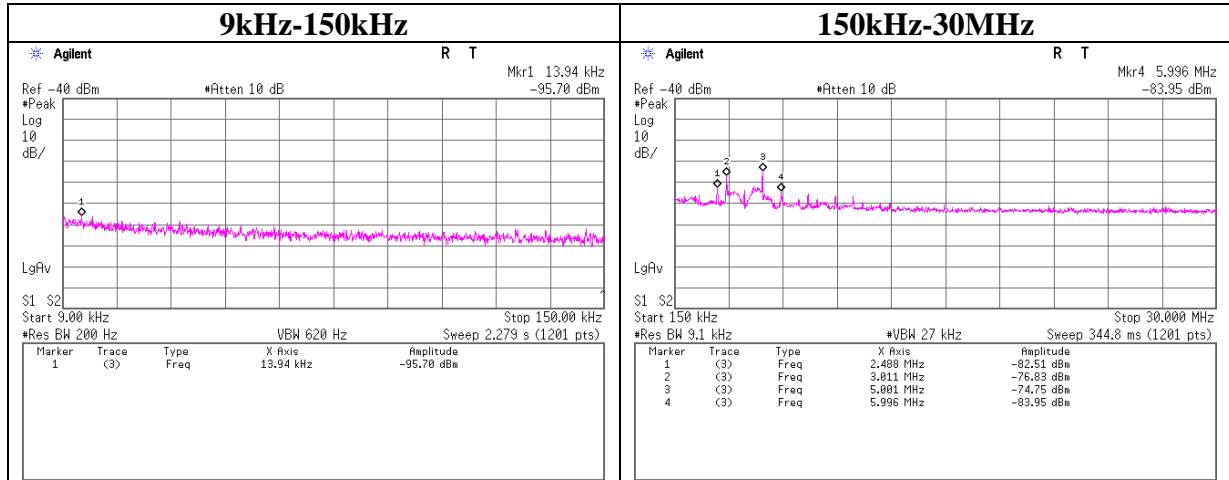

Frequency [kHz]	Reading [dBm]	Cable Loss [dB]	Attenuator [dB]	Antenna Gain [dBi]	EIRP [dBm]	Distance [m]	Ground bounce [dB]	E (field strength) [dBuV/m]	Limit [dBuV/m]
13.94	-95.7	0.6	9.9	2.0	-83.3	300.0	6.0	-22.0	44.7
2488	-82.5	0.6	9.8	2.0	-70.1	30.0	6.0	11.2	29.5
3011	-76.8	0.6	9.8	2.0	-64.4	30.0	6.0	16.9	29.5
5001	-74.8	0.6	9.8	2.0	-62.3	30.0	6.0	19.0	29.5
5996	-84.0	0.6	9.8	2.0	-71.5	30.0	6.0	9.8	29.5

E=EIRP-20log(D)+Ground bounce +104.8[dBuV/m]
 EIRP=Reading+Cable Loss+Attenuator+Antenna Gain

Power Density

Test place Head Office EMC Lab. No.7 Shielded Room
Report No. 10003724H
Date 02/06/2013
Temperature/ Humidity 24 deg. C / 35% RH
Engineer Katsunori Okai
Mode Tx, LE

Freq. [MHz]	Reading [dBm]	Cable Loss [dB]	Atten. [dB]	Result [dBm]	Limit [dBm]	Margin [dB]
2402	-24.25	1.41	10.03	-12.81	8.00	20.81
2440	-24.85	1.41	10.03	-13.41	8.00	21.41
2480	-25.47	1.42	10.03	-14.02	8.00	22.02

Sample Calculation:

Result = Reading + Cable Loss (including the cable(s) customer supplied) + Attenuator

UL Japan, Inc.

Head Office EMC Lab.

4383-326 Asama-cho, Ise-shi, Mie-ken 516-0021 JAPAN

Telephone : +81 596 24 8116

Facsimile : +81 596 24 8124

Power Density

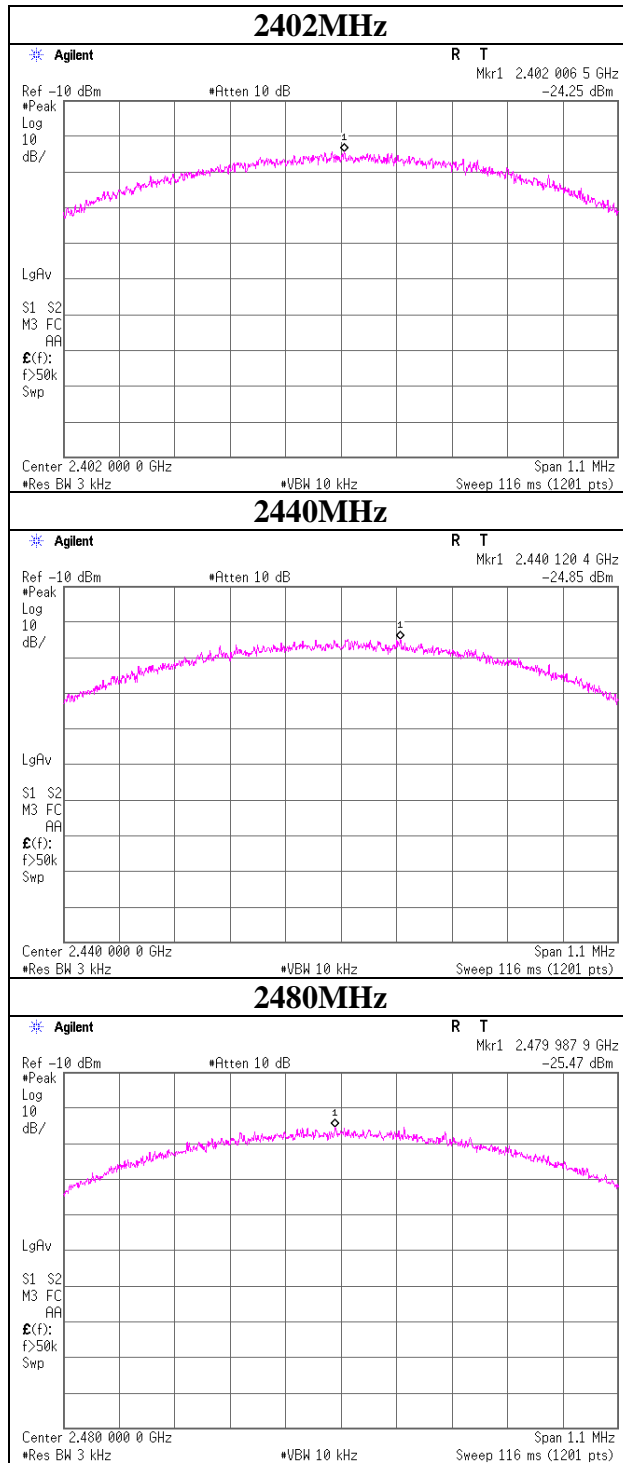

99% Occupied Bandwidth

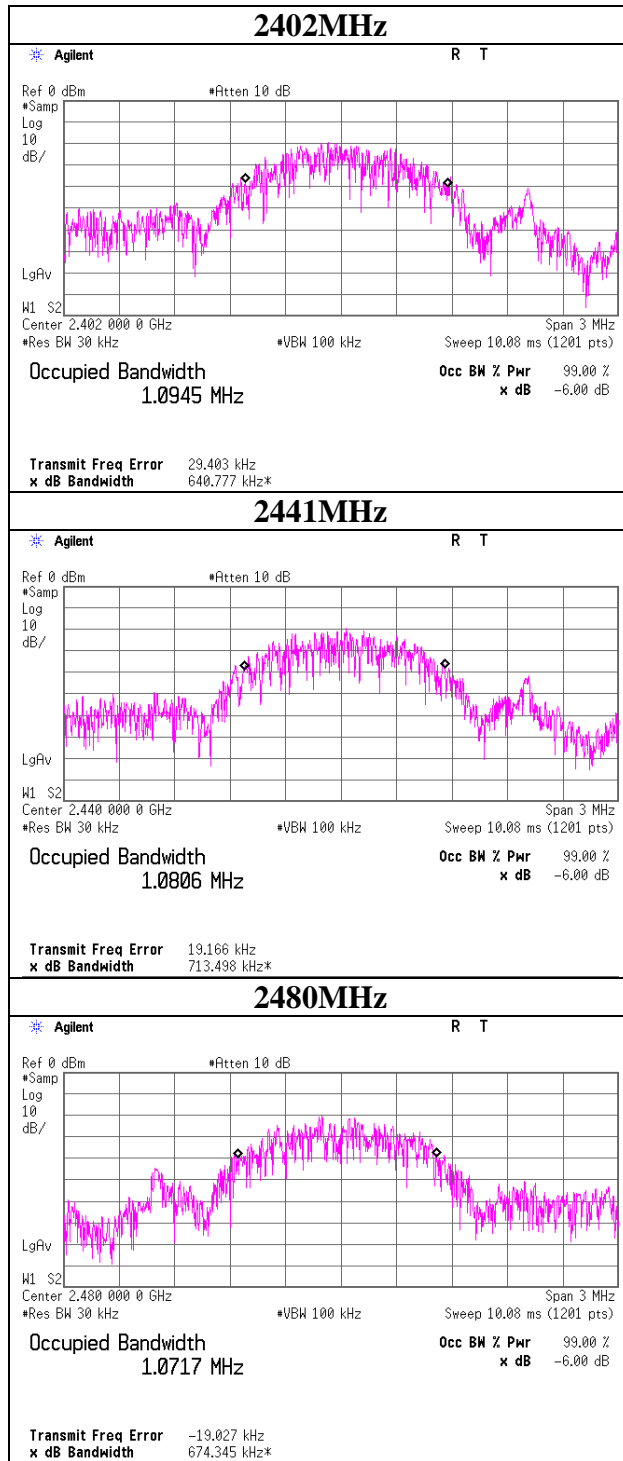

APPENDIX 2: Test instruments

EMI test equipment

Control No.	Instrument	Manufacturer	Model No	Serial No	Test Item	Calibration Date * Interval(month)
MOS-04	Digital Humidity Indicator	N.T	NT-1800	MOS04	AT	2012/02/06 * 12
MSA-04	Spectrum Analyzer	Agilent	E4448A	US44300523	AT/RE	2012/04/06 * 12
MPM-09	Power Meter	Anritsu	ML2495A	6K00003348	AT	2012/10/08 * 12
MPSE-12	Power sensor	Anritsu	MA2411B	011598	AT	2012/10/08 * 12
MCC-144	Microwave Cable	Junkosha	MWX221	1207S407	AT	2012/08/03 * 12
MAT-25	Attenuator(10dB) (above1GHz)	Agilent	8493C	71642	AT	2012/06/27 * 12
MCC-64	Coaxial Cable	UL Japan	-	-	AT	2012/03/22 * 12
MAT-10	Attenuator(10dB)	Weinschel Corp	2	BL1173	AT	2012/11/06 * 12
MAEC-02	Semi Anechoic Chamber(NSA)	TDK	Semi Anechoic Chamber 3m	DA-06902	RE	2012/06/29 * 12
MOS-22	Thermo-Hygrometer	Custom	CTH-201	0003	RE	2012/02/06 * 12
MJM-14	Measure	KOMELON	KMC-36	-	RE	-
COTS-MEMI	EMI measurement program	TSJ	TEPTO-DV	-	RE	-
MHA-06	Horn Antenna 1-18GHz	Schwarzbeck	BBHA9120D	254	RE	2012/02/22 * 12
MPA-10	Pre Amplifier	Agilent	8449B	3008A02142	RE	2013/01/10 * 12
MHA-17	Horn Antenna 15-40GHz	Schwarzbeck	BBHA9170	BBHA9170307	RE	2012/06/27 * 12
MCC-132	Microwave Cable	HUBER+SUHNER	SUCOFLEX104	336161/4(1m) / 340639(5m)	RE	2012/09/05 * 12
MHF-06	High Pass Filter 3.5-24GHz	TOKIMEC	TF323DCA	601	RE	2012/05/30 * 12
MAEC-04	Semi Anechoic Chamber(NSA)	TDK	Semi Anechoic Chamber 3m	DA-10005	RE/CE	2012/02/29 * 12
MOS-15	Thermo-Hygrometer	Custom	CTH-180	-	RE/CE	2012/02/06 * 12
MJM-07	Measure	PROMART	SEN1955	-	RE/CE	-
MSA-10	Spectrum Analyzer	Agilent	E4448A	MY46180655	RE/CE	2012/02/03 * 12
MTR-07	Test Receiver	Rohde & Schwarz	ESCI	100635	RE	2012/04/05 * 12
MBA-05	Biconical Antenna	Schwarzbeck	BBA9106	1302	RE	2012/11/18 * 12
MLA-08	Logperiodic Antenna	Schwarzbeck	UKLP9140-A	N/A	RE	2012/11/18 * 12
MCC-50	Coaxial Cable	UL Japan	-	-	RE	2012/06/01 * 12
MAT-68	Attenuator	Anritsu	MP721B	6200961025	RE	2012/11/21 * 12
MPA-14	Pre Amplifier	SONOMA INSTRUMENT	310	260833	RE	2012/03/05 * 12
MLS-06	LISN(AMN)	Schwarzbeck	NSLK8127	8127363	CE	2013/01/07 * 12
MTA-31	Terminator	TME	CT-01	-	CE	2013/01/21 * 12
MAT-67	Attenuator	JFW Industries, Inc.	50FP-013H2 N	-	CE	2013/01/09 * 12
MCC-113	Coaxial cable	Fujikura/Suhner/TSJ	5D-2W(10m)/ SFM141(5m)/ 421-010(1m)/ sucoform141- PE(1m)/RFM- E121(Switcher)	-/04178	CE	2012/07/12 * 12

UL Japan, Inc.

Head Office EMC Lab.

4383-326 Asama-cho, Ise-shi, Mie-ken 516-0021 JAPAN

Telephone : +81 596 24 8116

Facsimile : +81 596 24 8124

The expiration date of the calibration is the end of the expired month.
All equipment is calibrated with valid calibrations. Each measurement data is traceable to the national or international standards.

As for some calibrations performed after the tested dates, those test equipment have been controlled by means of an unbroken chains of calibrations.

Test Item: CE: Conducted Emission
RE: Radiated Emission
AT: Antenna Terminal Conducted test