



# RADIO TEST REPORT

Test Report No. : 10180434H-A-R1

**Applicant** : Murata Manufacturing Company, Ltd.  
**Type of Equipment** : Communication Module  
**Model No.** : LBWA1ZZSNE-460  
**FCC ID** : VPYLBSN460  
**Test regulation** : FCC Part 15 Subpart C: 2013  
**Test Result** : Complied

1. This test report shall not be reproduced in full or partial, without the written approval of UL Japan, Inc.
2. The results in this report apply only to the sample tested.
3. This sample tested is in compliance with the above regulation.
4. The test results in this report are traceable to the national or international standards.
5. This test report must not be used by the customer to claim product certification, approval, or endorsement by NVLAP, NIST, or any agency of the Federal Government.
6. This report is a revised version of 10180434H-A. 10180434H-A is replaced with this report.

**Date of test:** January 11 to 22, 2014

**Representative test engineer:**

*H. Kukita*

Hiroshi Kukita  
Engineer of WiSE Japan,  
UL Verification Service

**Approved by:**

*M. Nishiyama*

Masanori Nishiyama  
Manager of WiSE Japan,  
UL Verification Service



NVLAP LAB CODE: 200572-0

This laboratory is accredited by the NVLAP LAB CODE 200572-0, U.S.A. The tests reported herein have been performed in accordance with its terms of accreditation.  
\*As for the range of Accreditation in NVLAP, you may refer to the WEB address,  
<http://www.ul.com/japan/jpn/pages/services/emc/about/mar1/index.jsp#nvlap>

**UL Japan, Inc.**

**Head Office EMC Lab.**

4383-326 Asama-cho, Ise-shi, Mie-ken 516-0021 JAPAN

Telephone : +81 596 24 8999

Facsimile : +81 596 24 8124

13-EM-F0429

## REVISION HISTORY

**Original Test Report No.: 10180434H-A**

Revision	Test report No.	Date	Page revised	Contents
- (Original)	10180434H-A	February 6, 2014	-	-
1	10180434H-A-R1	February 12, 2014	8	Correction of power setting information

<b>CONTENTS</b>	<b>PAGE</b>
<b>SECTION 1: Customer information.....</b>	<b>4</b>
<b>SECTION 2: Equipment under test (E.U.T.).....</b>	<b>4</b>
<b>SECTION 3: Test specification, procedures &amp; results.....</b>	<b>5</b>
<b>SECTION 4: Operation of E.U.T. during testing.....</b>	<b>8</b>
<b>SECTION 5: Conducted Emission.....</b>	<b>11</b>
<b>SECTION 6: Radiated Spurious Emission .....</b>	<b>12</b>
<b>SECTION 7: Antenna Terminal Conducted Tests.....</b>	<b>13</b>
<b>APPENDIX 1: Data of EMI test.....</b>	<b>14</b>
Conducted Emission .....	14
6dB Bandwidth .....	16
Maximum Peak Output Power .....	18
Average Output Power .....	19
Radiated Spurious Emission .....	20
Conducted Spurious Emission .....	24
Power Density .....	25
99% Occupied Bandwidth .....	27
<b>APPENDIX 2: Test instruments .....</b>	<b>28</b>
<b>APPENDIX 3: Photographs of test setup.....</b>	<b>30</b>
Conducted Emission .....	30
Radiated Spurious Emission .....	31
Worst Case Position (Horizontal: Y-axis/ Vertical:Z-axis) .....	32

---

**UL Japan, Inc.**

**Head Office EMC Lab.**

4383-326 Asama-cho, Ise-shi, Mie-ken 516-0021 JAPAN

Telephone : +81 596 24 8999

Facsimile : +81 596 24 8124

## **SECTION 1: Customer information**

Company Name : Murata Manufacturing Company, Ltd.  
Address : 10-1, Higashikotari 1-chome, Nagaokakyo-shi, Kyoto 617-8555 Japan  
Telephone Number : +81-75-955-6375  
Facsimile Number : +81- 75-955-6634  
Contact Person : Takaharu Kawakatsu

## **SECTION 2: Equipment under test (E.U.T.)**

### **2.1 Identification of E.U.T.**

Type of Equipment : Communication Module  
Model No. : LBWA1ZZSNE-460  
Serial No. : Refer to Section 4, Clause 4.2  
Rating : DC3.3V  
Receipt Date of Sample : January 8, 2014  
Country of Mass-production : Japan  
Condition of EUT : Production prototype  
(Not for Sale: This sample is equivalent to mass-produced items.)  
Modification of EUT : No Modification by the test lab

### **2.2 Product Description**

#### **Radio Specification**

Radio Type : Transceiver  
Frequency of Operation : 2412-2462MHz  
Modulation : DSSS  
Power Supply (radio part input) : DC1.8V/3.3V  
Antenna type : Chip Antenna  
Antenna Gain : 0.45dBi

---

**UL Japan, Inc.**

**Head Office EMC Lab.**

4383-326 Asama-cho, Ise-shi, Mie-ken 516-0021 JAPAN

Telephone : +81 596 24 8999

Facsimile : +81 596 24 8124

## **SECTION 3: Test specification, procedures & results**

### **3.1 Test Specification**

Test Specification : FCC Part 15 Subpart C: 2013, final revised on September 30, 2013 and effective October 30, 2013

Title : FCC 47CFR Part15 Radio Frequency Device Subpart C Intentional Radiators  
Section 15.207 Conducted limits  
Section 15.247 Operation within the bands 902-928MHz,  
2400-2483.5MHz, and 5725-5850MHz

### **3.2 Procedures and results**

Item	Test Procedure	Specification	Worst margin	Results	Remarks
Conducted Emission	FCC: ANSI C63.4:2003 7. AC powerline Conducted Emission measurements IC: RSS-Gen 7.2.4	FCC: Section 15.207 IC: RSS-Gen 7.2.4	QP 5.1dB, 5.86945MHz, L AV 5.5dB, 5.86945MHz, L	Complied	-
6dB Bandwidth	FCC: "Guidance for Performing Compliance Measurements on Digital Transmission Systems (DTS) Operating Under §15.247(issued on April 9, 2013)" IC: RSS-Gen 4.6.2	FCC: Section 15.247(a)(2) IC: RSS-210 A8.2(a)	See data.	Complied	Conducted
Maximum Peak Output Power	FCC: "Guidance for Performing Compliance Measurements on Digital Transmission Systems (DTS) Operating Under §15.247(issued on April 9, 2013)" IC: RSS-Gen 4.8	FCC: Section 15.247(b)(3) IC: RSS-210 A8.4(4)		Complied	Conducted
Power Density	FCC: "Guidance for Performing Compliance Measurements on Digital Transmission Systems (DTS) Operating Under §15.247(issued on April 9, 2013)" IC: -	FCC: Section 15.247 (e) IC: RSS-210 A8.2(b)		Complied	Conducted
Spurious Emission Restricted Band Edges	FCC: "Guidance for Performing Compliance Measurements on Digital Transmission Systems (DTS) Operating Under §15.247(issued on April 9, 2013)" IC: RSS-Gen 4.9	FCC: Section15.247(d) IC: RSS-210 A8.5 RSS-Gen 7.2.3		9.3dB 48.000MHz, QP, Vert.	Complied

Note: UL Japan, Inc.'s EMI Work Procedures No. 13-EM-W0420 and 13-EM-W0422.

\*In case any questions arise about test procedure, ANSI C63.4: 2003 is also referred.

**UL Japan, Inc.**

**Head Office EMC Lab.**

4383-326 Asama-cho, Ise-shi, Mie-ken 516-0021 JAPAN

Telephone : +81 596 24 8999

Facsimile : +81 596 24 8124

**FCC 15.31 (e)**

The EUT has the power supply regulator. However one of the input voltages to RF part doesn't go through the regulator. The stable voltage will be supplied by the end product, which will be required to have a power supply regulator. Therefore, the EUT complies with the requirement.

**FCC Part 15.203 Antenna requirement**

It is impossible for end users to replace the antenna, because it is soldered on the circuit board. Therefore, the equipment complies with the antenna requirement of Section 15.203.

**3.3 Addition to standard**

Item	Test Procedure	Specification	Worst margin	Results	Remarks
99% Occupied Bandwidth	IC: RSS-Gen 4.6.1	IC: RSS-Gen 4.6.1	N/A	-	Conducted

Other than above, no addition, exclusion nor deviation has been made from the standard.

**3.4 Uncertainty**

**EMI**

The following uncertainties have been calculated to provide a confidence level of 95% using a coverage factor k=2.

Test room (semi-anechoic chamber)	Conducted emission (+dB)
	150kHz-30MHz
No.1	3.5dB
No.2	3.5dB
No.3	3.6dB
No.4	3.5dB

Test room (semi-anechoic chamber)	Radiated emission						
	(3m*)(+dB)				(1m*)(+dB)		(0.5m*)(+dB)
	9kHz -30MHz	30MHz -300MHz	300MHz -1GHz	1GHz -10GHz	10GHz -18GHz	18GHz -26.5GHz	26.5GHz -40GHz
No.1	4.0dB	5.1dB	5.0dB	5.1dB	6.0dB	4.9dB	4.3dB
No.2	3.9dB	5.2dB	5.0dB	4.9dB	5.9dB	4.7dB	4.2dB
No.3	4.3dB	5.1dB	5.2dB	5.2dB	6.0dB	4.8dB	4.2dB
No.4	4.6dB	5.2dB	5.0dB	5.2dB	6.0dB	5.7dB	4.2dB

\*3m/1m/0.5m = Measurement distance

Power meter (+dB)	
Below 1GHz	Above 1GHz
0.7dB	1.5dB

Antenna terminal conducted emission and Power density (+dB)			Antenna terminal conducted emission (+dB)		Channel power (+dB)
Below 1GHz	1GHz-3GHz	3GHz-18GHz	18GHz-26.5GHz	26.5GHz-40GHz	
1.5dB	1.7dB	2.8dB	2.8dB	2.9dB	2.6dB

Conducted Emission test

The data listed in this test report has enough margin, more than the site margin.

Radiated emission test(3m)

The data listed in this test report has enough margin, more than the site margin.

**UL Japan, Inc.**

**Head Office EMC Lab.**

4383-326 Asama-cho, Ise-shi, Mie-ken 516-0021 JAPAN

Telephone : +81 596 24 8999

Facsimile : +81 596 24 8124

### 3.5 Test Location

UL Japan, Inc. Head Office EMC Lab. \*NVLAP Lab. code: 200572-0  
 4383-326 Asama-cho, Ise-shi, Mie-ken 516-0021 JAPAN  
 Telephone : +81 596 24 8999 Facsimile : +81 596 24 8124

	FCC Registration Number	IC Registration Number	Width x Depth x Height (m)	Size of reference ground plane (m) / horizontal conducting plane	Other rooms
No.1 semi-anechoic chamber	313583	2973C-1	19.2 x 11.2 x 7.7m	7.0 x 6.0m	No.1 Power source room
No.2 semi-anechoic chamber	655103	2973C-2	7.5 x 5.8 x 5.2m	4.0 x 4.0m	-
No.3 semi-anechoic chamber	148738	2973C-3	12.0 x 8.5 x 5.9m	6.8 x 5.75m	No.3 Preparation room
No.3 shielded room	-	-	4.0 x 6.0 x 2.7m	N/A	-
No.4 semi-anechoic chamber	134570	2973C-4	12.0 x 8.5 x 5.9m	6.8 x 5.75m	No.4 Preparation room
No.4 shielded room	-	-	4.0 x 6.0 x 2.7m	N/A	-
No.5 semi-anechoic chamber	-	-	6.0 x 6.0 x 3.9m	6.0 x 6.0m	-
No.6 shielded room	-	-	4.0 x 4.5 x 2.7m	4.0 x 4.5 m	-
No.6 measurement room	-	-	4.75 x 5.4 x 3.0m	4.75 x 4.15 m	-
No.7 shielded room	-	-	4.7 x 7.5 x 2.7m	4.7 x 7.5m	-
No.8 measurement room	-	-	3.1 x 5.0 x 2.7m	N/A	-
No.9 measurement room	-	-	8.0 x 4.6 x 2.8m	2.4 x 2.4m	-
No.11 measurement room	-	-	6.2 x 4.7 x 3.0m	2.4 x 3.4m	-

\* Size of vertical conducting plane (for Conducted Emission test) : 2.0 x 2.0m for No.1, No.2, No.3, and No.4 semi-anechoic chambers and No.3 and No.4 shielded rooms.

### 3.6 Data of EMI, Test instruments, and Test set up

Refer to APPENDIX.

## UL Japan, Inc.

### Head Office EMC Lab.

4383-326 Asama-cho, Ise-shi, Mie-ken 516-0021 JAPAN

Telephone : +81 596 24 8999

Facsimile : +81 596 24 8124

## **SECTION 4: Operation of E.U.T. during testing**

### **4.1 Operating Mode(s)**

<b>Mode</b>	<b>Remarks*</b>
IEEE 802.11b (11b)	11Mbps, PN9
*The worst condition was determined based on the test result of Maximum Peak Output Power (Mid Channel)	
*Power of the EUT was set by the software as follows; Power settings: AT+EXTPA=1 AT+WP=10 Software : GainSpan FW : GEPS 2.3.5(WPS) *This setting of software is the worst case. Any conditions under the normal use do not exceed the condition of setting. In addition, end users cannot change the settings of the output power of the product.	

\*Details of Operating mode(s)

<b>Test Item</b>	<b>Operating Mode</b>	<b>Tested frequency</b>
Conducted Emission	11b	2412MHz
6dB Bandwidth		2437MHz
Maximum Peak Output Power		2462MHz
Spurious Emission (Radiated)		
Power Density		
99% Occupied Bandwidth		
Spurious Emission (Conducted)	11b Tx *1)	2416MHz *1)
*1) The mode was tested as a representative, because it had the highest power at antenna terminal test.		

**UL Japan, Inc.**

**Head Office EMC Lab.**

4383-326 Asama-cho, Ise-shi, Mie-ken 516-0021 JAPAN

Telephone : +81 596 24 8999

Facsimile : +81 596 24 8124



## 4.2 Configuration and peripherals

[Conducted Emission]

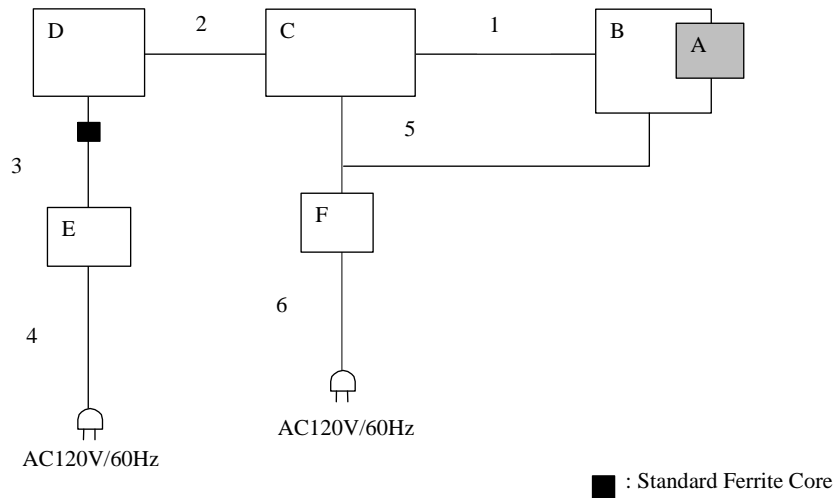

\* Cabling and setup(s) were taken into consideration and test data was taken under worse case conditions.

### Description of EUT and Support equipment

No.	Item	Model number	Serial number	Manufacturer	Remarks
A	Communication Module	LBWA1ZZSNE-460	001	MURATA	EUT
B	Jig board	-	-	MURATA	-
C	Jig board	-	-	MURATA	-
D	Laptop PC	T30	97-1DZ8M	IBM	-
E	AC Adaptor	02K6750	11S02K6750Z1Z2UP3561HY	IBM	-
F	Power Supply	PMG35-2A	13090501	KIKUSUI	-

### List of cables used

No.	Name	Length (m)	Shield		Remarks
			Cable	Connector	
1	Signal Cable	0.3	Unshielded	Unshielded	-
2	UART-USB Cable	1.8	Shielded	Shielded	-
3	DC Cable	1.8	Unshielded	Unshielded	-
4	AC Cable	1.0	Unshielded	Unshielded	-
5	DC Cable	0.6	Unshielded	Unshielded	-
6	AC Cable	0.8	Unshielded	Unshielded	-

**UL Japan, Inc.**

**Head Office EMC Lab.**

4383-326 Asama-cho, Ise-shi, Mie-ken 516-0021 JAPAN

Telephone : +81 596 24 8999

Facsimile : +81 596 24 8124

[Antenna Terminal Conducted / Radiated Emission]

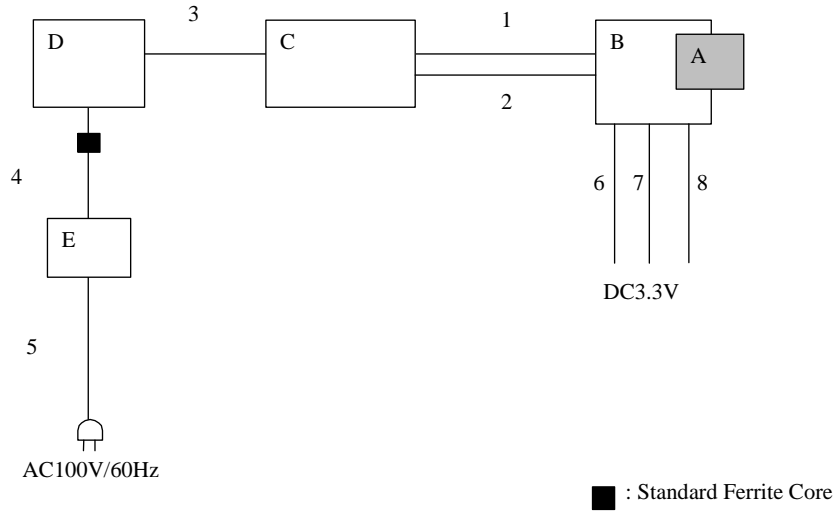

\* Cabling and setup(s) were taken into consideration and test data was taken under worse case conditions.

**Description of EUT and Support equipment**

No.	Item	Model number	Serial number	Manufacturer	Remarks
A	Communication Module	LBWA1ZZSNE-460	001	MURATA	EUT
B	Jig board	-	-	MURATA	-
C	Jig board	-	-	MURATA	-
D	Laptop PC	7661-CB9	L3-R2055	Lenovo	-
E	AC Adaptor	92P1156	11S92P1156Z1ZDX N85M5PY	Lenovo	-

\* RE: Radiated Emission, AT: Antenna Terminal Conducted Test

**List of cables used**

No.	Name	Length (m)	Shield		Remarks
			Cable	Connector	
1	Signal Cable	0.3	Unshielded	Unshielded	-
2	Signal Cable	0.3	Unshielded	Unshielded	-
3	USB Cable	1.8	Shielded	Shielded	-
4	DC Cable	1.8	Unshielded	Unshielded	-
5	AC Cable	1.0	Unshielded	Unshielded	-
6	DC Cable	2.0	Unshielded	Unshielded	-
7	DC Cable	2.0	Unshielded	Unshielded	-
8	DC Cable	2.0	Unshielded	Unshielded	-

**UL Japan, Inc.**

**Head Office EMC Lab.**

4383-326 Asama-cho, Ise-shi, Mie-ken 516-0021 JAPAN

Telephone : +81 596 24 8999

Facsimile : +81 596 24 8124

## **SECTION 5: Conducted Emission**

### **Test Procedure and conditions**

EUT was placed on a urethane platform of nominal size, 1.0m by 1.5m, raised 0.8m above the conducting ground plane.

The rear of tabletop was located 40cm to the vertical conducting plane. The rear of EUT, including peripherals aligned and flushed with rear of tabletop. All other surfaces of tabletop were at least 80cm from any other grounded conducting surface. EUT was located 80cm from a Line Impedance Stabilization Network (LISN)/ Artificial mains Network (AMN) and excess AC cable was bundled in center.

For the tests on EUT with other peripherals (as a whole system)

I/O cables that were connected to the peripherals were bundled in center. They were folded back and forth forming a bundle 30cm to 40cm long and were hanged at a 40cm height to the ground plane. All unused 50ohm connectors of the LISN(AMN) were resistivity terminated in 50ohm when not connected to the measuring equipment.

The AC Mains Terminal Continuous disturbance Voltage has been measured with the EUT in a Semi Anechoic Chamber.

The EUT was connected to a LISN (AMN).

An overview sweep with peak detection has been performed.

The test results and limit are rounded off to one decimal place, so some differences might be observed.

<b>Detector</b>	<b>: QP and CISPR AV</b>
<b>Measurement range</b>	<b>: 0.15-30MHz</b>
<b>Test data</b>	<b>: APPENDIX</b>
<b>Test result</b>	<b>: Pass</b>

---

**UL Japan, Inc.**

**Head Office EMC Lab.**

4383-326 Asama-cho, Ise-shi, Mie-ken 516-0021 JAPAN

Telephone : +81 596 24 8999

Facsimile : +81 596 24 8124

## **SECTION 6: Radiated Spurious Emission**

### **Test Procedure**

It was measured based on "11.0 Emissions in non-restricted frequency bands" of "Guidance for Performing Compliance Measurements on Digital Transmission Systems (DTS) Operating Under §15.247 (Issued on April 9, 2013)".

EUT was placed on a urethane platform of nominal size, 1.0m by 1.5m, raised 0.8m above the conducting ground plane.

The Radiated Electric Field Strength has been measured in a Semi Anechoic Chamber with a ground plane.

The height of the measuring antenna varied between 1 and 4m and EUT was rotated a full revolution in order to obtain the maximum value of the electric field strength.

The measurements were performed for both vertical and horizontal antenna polarization with the Test Receiver, or the Spectrum Analyzer.

The measurements were made with the following detector function of the test receiver and the Spectrum analyzer (in linear mode).

The test was made with the detector (RBW/VBW) in the following table.

When using Spectrum analyzer, the test was made with adjusting span to zero by using peak hold.

### **Test Antennas are used as below;**

Frequency	Below 30MHz	30MHz to 300MHz	300MHz to 1GHz	Above 1GHz
Antenna Type	Loop	Biconical	Logperiodic	Horn

In any 100kHz bandwidth outside the restricted band in which the spread spectrum intentional radiator is operating, the radio frequency power that is produced by the intentional radiator confirmed 20dB below that in the 100kHz bandwidth within the band that contains the highest level of the desired power, based on a radiated measurement.

### **20dBc was applied to the frequency over the limit of FCC 15.209 / Table 5 of RSS-Gen 7.2.5(IC) and outside the restricted band of FCC15.205 / Table 3 of RSS-Gen 7.2.2 (IC).**

Frequency	Below 1GHz	Above 1GHz		20dBc
Instrument used	Test Receiver	Spectrum Analyzer		Spectrum Analyzer
Detector	QP	PK	AV *1)	PK
IF Bandwidth	BW 120kHz(T/R)	RBW: 1MHz VBW: 3MHz	Average Power Method: <u>WLAN: 12.2.5.1</u> RBW: 1MHz VBW: 3MHz Detector: Power Averaging (RMS) Trace: Free Run	RBW: 100kHz VBW: 300kHz (S/A)
Test Distance	3m	3m (below 10GHz), 1m *2) (above 10GHz)		3m (below 10GHz), 1m *2) (above 10GHz)

\*1) Average Power Measurement was performed based on 6.0 & 12.2.5 of "Guidance for Performing Compliance Measurements on Digital Transmission Systems (DTS) Operating Under §15.247 (Issued on April 9, 2013)"

\*2) Distance Factor:  $20 \times \log(3.0\text{m}/1.0\text{m}) = 9.5\text{dB}$

- The carrier level and noise levels were confirmed at each position of X, Y and Z axes of EUT to see the position of maximum noise, and the test was made at the position that has the maximum noise.

The test results and limit are rounded off to one decimal place, so some differences might be observed.

**Measurement range** : 30M-26.5GHz  
**Test data** : APPENDIX  
**Test result** : Pass

**UL Japan, Inc.**

**Head Office EMC Lab.**

4383-326 Asama-cho, Ise-shi, Mie-ken 516-0021 JAPAN

Telephone : +81 596 24 8999

Facsimile : +81 596 24 8124

## **SECTION 7: Antenna Terminal Conducted Tests**

### **Test Procedure**

The tests were made with below setting connected to the antenna port.

<b>Test</b>	<b>Span</b>	<b>RBW</b>	<b>VBW</b>	<b>Sweep time</b>	<b>Detector</b>	<b>Trace</b>	<b>Instrument used</b>
6dB Bandwidth	20MHz	100kHz	300kHz	Auto	Peak	Max Hold	Spectrum Analyzer
99% Occupied Bandwidth	Enough width to display 20dB Bandwidth	1 to 3% of Span	Three times of RBW	Auto	Sample	Clear write	Spectrum Analyzer
Maximum Peak Output Power	-	-	-	Auto	Peak/ Average *1)	-	Power Meter (Sensor: 50MHz BW)
Peak Power Density	1.5 times the 6dB Bandwidth	3kHz	10kHz	Auto	Peak	Max Hold	Spectrum Analyzer *2)
Conducted Spurious Emission *3)	9kHz to 150kHz	200Hz	620Hz	Auto	Peak	Max Hold	Spectrum Analyzer
	150kHz to 30MHz	9.1kHz	27kHz				
*1) Reference data *2) Section 10.2 Method PKPSD (peak PSD) of "Guidance for Performing Compliance Measurements on Digital Transmission Systems (DTS) Operating Under §15.247 (Issued on April 9, 2013)". *3) In the frequency range below 30MHz, RBW was narrowed to separate the noise contents. Then, wide-band noise near the limit was checked separately, however the noise was not detected as shown in the chart.(9kHz-150kHz:RBW=200Hz, 150kHz-30MHz:RBW=9.1kHz)							

The test results and limit are rounded off to two decimals place, so some differences might be observed.

**Test data** : APPENDIX  
**Test result** : Pass

**UL Japan, Inc.**

**Head Office EMC Lab.**

4383-326 Asama-cho, Ise-shi, Mie-ken 516-0021 JAPAN

Telephone : +81 596 24 8999

Facsimile : +81 596 24 8124

**APPENDIX 1: Data of EMI test**

**Conducted Emission**

**DATA OF CONDUCTED EMISSION TEST**

UL Japan, Inc. Head Office EMC Lab. No.4 Semi Anechoic Chamber  
 Date : 2014/01/22

Report No. : 100180434H  
 Temp./Humi. : 22deg. C / 30% RH  
 Engineer : Masatoshi Nishiguchi

Mode / Remarks : WLAN 11b Tx 2462MHz 11Mbps

LIMIT : FCC15.207 QP  
 FCC15.207 AV

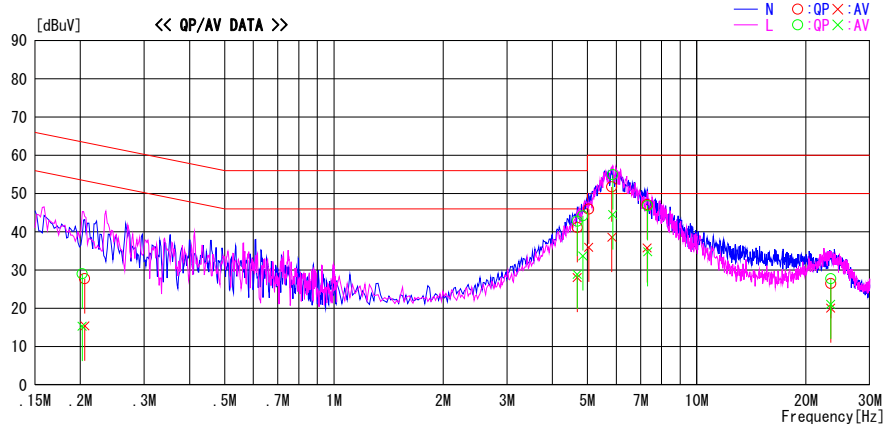

Frequency [MHz]	Reading Level		Corr. Factor	Results		Limit		Margin		Phase	Comment
	QP [dBuV]	AV [dBuV]		QP [dBuV]	AV [dBuV]	QP [dBuV]	AV [dBuV]	QP [dB]	AV [dB]		
0.20579	14.4	2.1	13.3	27.7	15.4	63.4	53.4	35.7	38.0	N	
4.68798	27.2	14.2	13.9	41.1	28.1	56.0	46.0	14.9	17.9	N	
5.04020	32.0	22.1	13.9	45.9	36.0	60.0	50.0	14.1	14.0	N	
5.83310	37.8	24.7	13.9	51.7	38.6	60.0	50.0	8.3	11.4	N	
7.30540	33.0	21.7	14.1	47.1	35.8	60.0	50.0	12.9	14.2	N	
23.41037	11.4	5.0	15.1	26.5	20.1	60.0	50.0	33.5	29.9	N	
0.20230	15.7	2.0	13.3	29.0	15.3	63.5	53.5	34.5	38.2	L	
4.68798	28.8	15.0	13.9	42.7	28.9	56.0	46.0	13.3	17.1	L	
4.85157	30.3	19.8	13.9	44.2	33.7	56.0	46.0	11.8	12.3	L	
5.86945	41.0	30.6	13.9	54.9	44.5	60.0	50.0	5.1	5.5	L	
7.32358	32.7	20.7	14.1	46.8	34.8	60.0	50.0	13.2	15.2	L	
23.41037	12.6	6.0	15.1	27.7	21.1	60.0	50.0	32.3	28.9	L	

CHART: WITH FACTOR, Peak hold data. CALCULATION: RESULT[dBuV]=READING[dBuV]+C. F [dB] (LISN+CABLE+ATTEN.)  
 Except for the above table : adequate margin data below the limits.

## Conducted Emission

Test place : Head Office EMC Lab. No.4 Semi Anechoic Chamber  
Report No. : 10180434H  
Date : 01/22/2014  
Temperature/ Humidity : 22 deg.C./ 30%  
Engineer : Masatoshi Nishiguchi  
Mode : 11b Tx

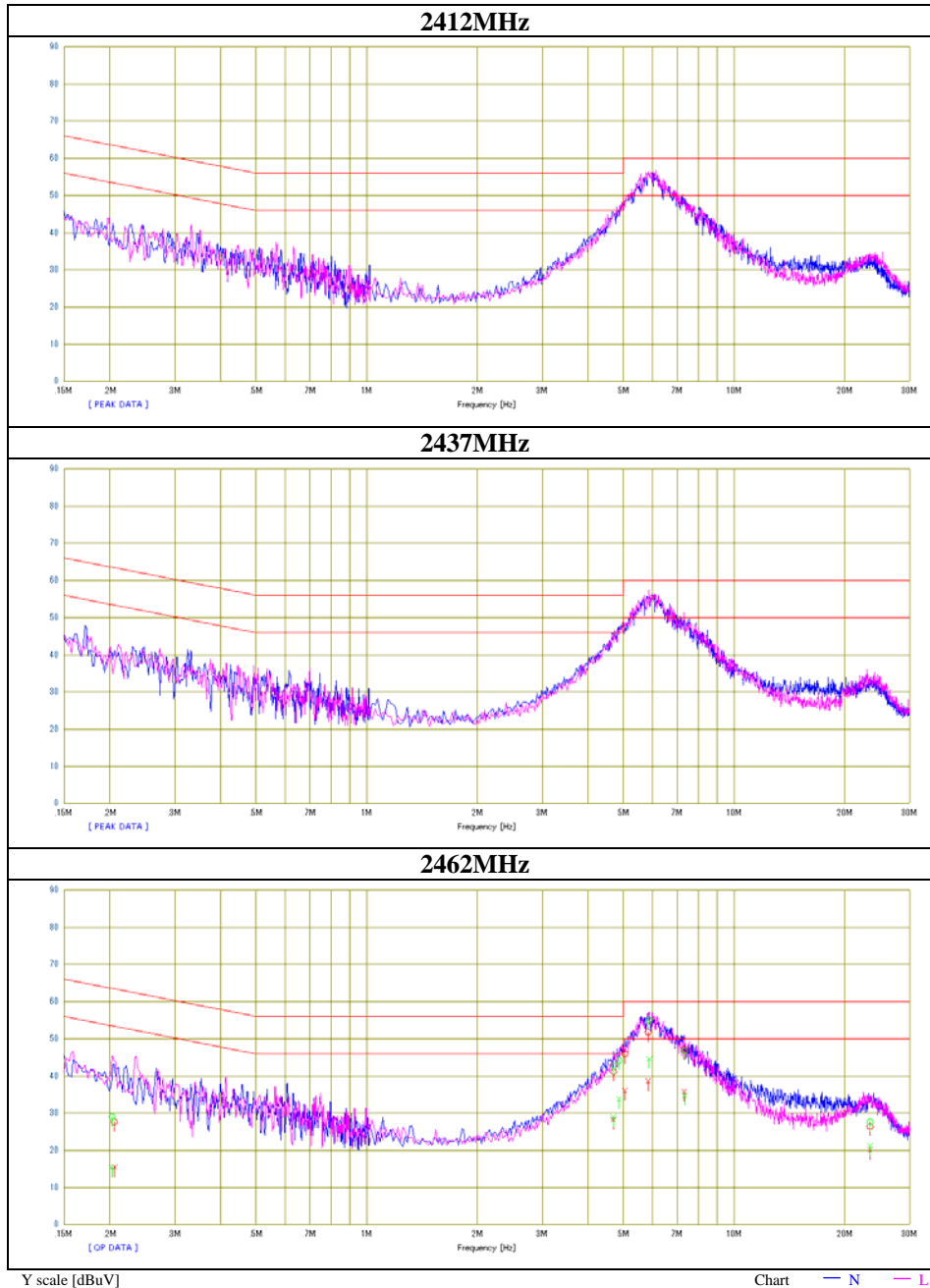

**UL Japan, Inc.**

**Head Office EMC Lab.**

4383-326 Asama-cho, Ise-shi, Mie-ken 516-0021 JAPAN

Telephone : +81 596 24 8999

Facsimile : +81 596 24 8124

### 6dB Bandwidth

Test place Head Office EMC Lab. No.11 Measurement Room  
Report No. 10180434H  
Date 01/22/2014  
Temperature/ Humidity 23 deg.C./ 58%  
Engineer Shinya Watanabe  
Mode Tx 11b

11b

Frequency [MHz]	6dB Bandwidth [MHz]	Limit [kHz]
2412	8.892	>500
2437	8.887	>500
2462	8.890	>500

---

**UL Japan, Inc.**

**Head Office EMC Lab.**

4383-326 Asama-cho, Ise-shi, Mie-ken 516-0021 JAPAN

Telephone : +81 596 24 8999

Facsimile : +81 596 24 8124



## 6dB Bandwidth

**11b**

**2412MHz**

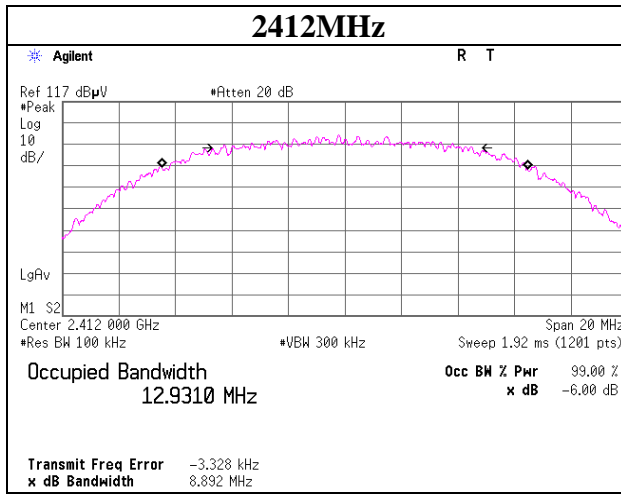

**2437MHz**

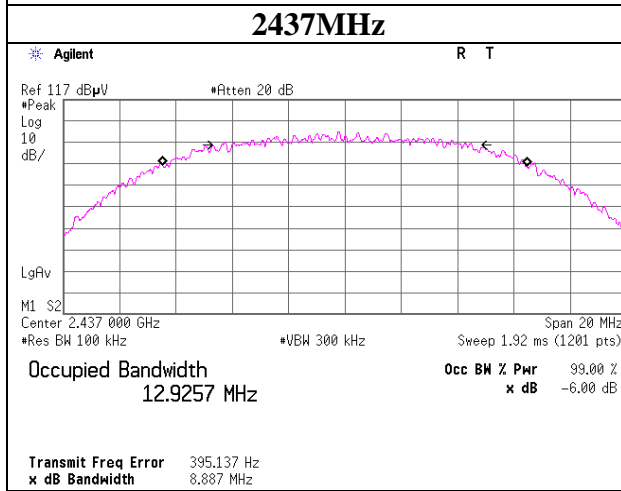

**2462MHz**

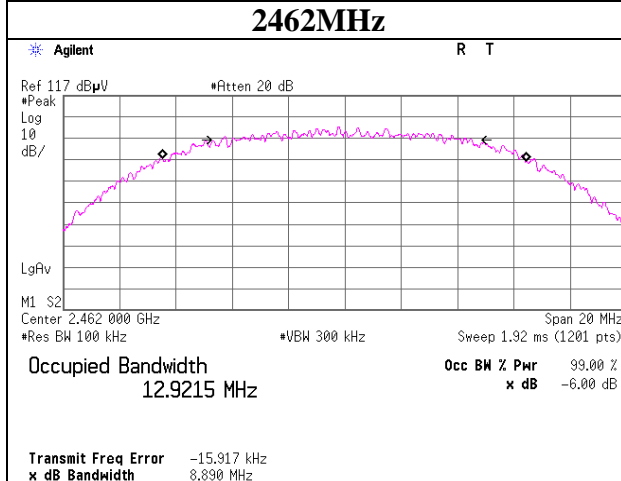

**UL Japan, Inc.**

**Head Office EMC Lab.**

4383-326 Asama-cho, Ise-shi, Mie-ken 516-0021 JAPAN

Telephone : +81 596 24 8999

Facsimile : +81 596 24 8124

### Maximum Peak Output Power

Test place : Head Office EMC Lab. No.11 Semi Anechoic Chamber  
 Report No. : 10180434H  
 Date : 01/11/2014  
 Temperature/ Humidity : 22 deg.C./ 41%  
 Engineer : Hiroshi Kukita  
 Mode : 11b Tx

11b 11Mbps

Freq. [MHz]	Reading [dBm]	Cable Loss [dB]	Atten. [dB]	Result		Limit		Margin [dB]
				[dBm]	[mW]	[dBm]	[mW]	
2412	5.56	0.75	10.07	16.38	43.45	30.00	1000	13.62
2437	6.33	0.75	10.07	17.15	51.88	30.00	1000	12.85
2462	6.72	0.75	10.07	17.54	56.75	30.00	1000	12.46

Sample Calculation:

Result = Reading + Cable Loss (including the cable(s) customer supplied) + Attenuator

2437MHz

Rate [Mbps]	Reading [dBm]	Remark
1	6.06	
2	6.22	
5.5	5.72	
11	6.33	*

\*: Worst Rate

All comparizon were carried out on same frequency and measurement factors.

---

**UL Japan, Inc.**

**Head Office EMC Lab.**

4383-326 Asama-cho, Ise-shi, Mie-ken 516-0021 JAPAN

Telephone : +81 596 24 8999

Facsimile : +81 596 24 8124

### Average Output Power

Test place                      Head Office EMC Lab. No.11 Semi Anechoic Chamber  
Report No.                      10180434H  
Date                              01/11/2014  
Temperature/ Humidity        22 deg.C./ 41%  
Engineer                        Hiroshi Kukita  
Mode                              11b Tx

[AV]

11b      11Mbps

Freq. [MHz]	Reading [dBm]	Cable Loss [dB]	Atten. [dB]	Result		Limit		Margin [dB]
				[dBm]	[mW]	[dBm]	[mW]	
2412	2.73	0.75	10.07	13.55	22.65	30.00	1000	16.45
2437	3.40	0.75	10.07	14.22	26.42	30.00	1000	15.78
2462	3.91	0.75	10.07	14.73	29.72	30.00	1000	15.27

---

**UL Japan, Inc.**

**Head Office EMC Lab.**

4383-326 Asama-cho, Ise-shi, Mie-ken 516-0021 JAPAN

Telephone : +81 596 24 8999

Facsimile : +81 596 24 8124

## Radiated Spurious Emission

Test place	Head Office EMC Lab. No.3 Semi Anechoic Chamber
Report No.	10180434H
Date	01/11/2014
Temperature/ Humidity	22 deg.C./ 41%
Engineer	Hiroshi Kukita
Mode	11b Tx 2412MHz

Polarity	Frequency [MHz]	Detector	Reading [dBuV]	Ant.Fac. [dB/m]	Loss [dB]	Gain [dB]	Result [dBuV/m]	Limit [dBuV/m]	Margin [dB]	Remark
Hori	2390.000	PK	46.0	28.2	3.1	32.4	44.9	73.9	29.0	
Hori	4824.000	PK	NS	-	-	-	-	73.9	-	
Hori	7236.000	PK	NS	-	-	-	-	73.9	-	
Hori	9648.000	PK	NS	-	-	-	-	73.9	-	
Hori	2390.000	AV	37.4	28.2	3.1	32.4	36.3	53.9	17.6	
Hori	4824.000	AV	NS	-	-	-	-	53.9	-	
Hori	7236.000	AV	NS	-	-	-	-	53.9	-	
Hori	9648.000	AV	NS	-	-	-	-	53.9	-	
Vert	2390.000	PK	46.0	28.2	3.1	32.4	44.9	73.9	29.0	
Vert	4824.000	PK	NS	-	-	-	-	73.9	-	
Vert	7236.000	PK	NS	-	-	-	-	73.9	-	
Vert	9648.000	PK	NS	-	-	-	-	73.9	-	
Vert	2390.000	AV	35.5	28.2	3.1	32.4	34.4	53.9	19.5	
Vert	4824.000	AV	NS	-	-	-	-	53.9	-	
Vert	7236.000	AV	NS	-	-	-	-	53.9	-	
Vert	9648.000	AV	NS	-	-	-	-	53.9	-	

Result = Reading + Ant Factor + Loss (Cable+Attenuator+Filter-Distance factor(above 10GHz)) - Gain(Ant)

\*Other frequency noises omitted in this report were not seen or had enough margin (more than 20dB).

\*NS: Not supurious emission detected

\*The 10th harmonic was not seen so the result was its base noise level.

Distance factor: 10GHz-26.5GHz 20log(3.0m/1.0m)= 9.5dB

### 20dBc Data Sheet

Polarity	Frequency [MHz]	Detector	Reading [dBuV]	Ant Factor [dB/m]	Loss [dB]	Gain [dB]	Result [dBuV/m]	Limit [dBuV/m]	Margin [dB]	Remark
Hori	2412.000	PK	103.0	28.2	3.1	32.4	101.9	-	-	Carrier
Hori	2400.000	PK	49.2	28.2	3.1	32.4	48.1	81.9	33.8	
Vert	2412.000	PK	102.4	28.2	3.1	32.4	101.3	-	-	Carrier
Vert	2400.000	PK	47.0	28.2	3.1	32.4	45.9	81.3	35.4	

Result = Reading + Ant Factor + Loss (Cable+Attenuator+Filter-Distance factor(above 10GHz)) - Gain(Ampriifier)

**UL Japan, Inc.**

**Head Office EMC Lab.**

4383-326 Asama-cho, Ise-shi, Mie-ken 516-0021 JAPAN

Telephone : +81 596 24 8999

Facsimile : +81 596 24 8124

### Radiated Spurious Emission

Test place	Head Office EMC Lab. No.3 Semi Anechoic Chamber
Report No.	10180434H
Date	01/11/2014
Temperature/ Humidity	22 deg.C./ 41%
Engineer	Hiroshi Kukita
Mode	11b Tx 2437MHz

Polarity	Frequency [MHz]	Detector	Reading [dBuV]	Ant.Fac. [dB/m]	Loss [dB]	Gain [dB]	Duty Factor [dB]	Result [dBuV/m]	Limit [dBuV/m]	Margin [dB]	Remark
Hori	4874.000	PK	NS	-	-	-	-	-	-	73.9	-
Hori	7311.000	PK	NS	-	-	-	-	-	-	73.9	-
Hori	9748.000	PK	NS	-	-	-	-	-	-	73.9	-
Hori	4874.000	AV	NS	-	-	-	-	-	-	53.9	-
Hori	7311.000	AV	NS	-	-	-	-	-	-	53.9	-
Hori	9748.000	AV	NS	-	-	-	-	-	-	53.9	-
Vert	4874.000	PK	NS	-	-	-	-	-	-	73.9	-
Vert	7311.000	PK	NS	-	-	-	-	-	-	73.9	-
Vert	9748.000	PK	NS	-	-	-	-	-	-	73.9	-
Vert	4874.000	AV	NS	-	-	-	-	-	-	53.9	-
Vert	7311.000	AV	NS	-	-	-	-	-	-	53.9	-
Vert	9748.000	AV	NS	-	-	-	-	-	-	53.9	-

Result = Reading + Ant Factor + Loss (Cable+Attenuator+Filter-Distance factor(above 10GHz)) - Gain(Amplifier)

\*Other frequency noises omitted in this report were not seen or had enough margin (more than 20dB).

\*NS: Not supurious emission detected

Distance factor:      10GHz-26.5GHz    20log(3.0m/1.0m)= 9.5dB

**UL Japan, Inc.**

**Head Office EMC Lab.**

4383-326 Asama-cho, Ise-shi, Mie-ken 516-0021 JAPAN

Telephone : +81 596 24 8999

Facsimile : +81 596 24 8124

## Radiated Spurious Emission

Test place Head Office EMC Lab. No.3 Semi Anechoic Chamber  
Report No. 10180434H  
Date 01/11/2014  
Temperature/ Humidity 22 deg.C./ 41%  
Engineer Hiroshi Kukita  
Mode 11b Tx 2462MHz

Polarity	Frequency [MHz]	Detector	Reading [dBuV]	Ant.Fac. [dB/m]	Loss [dB]	Gain [dB]	Result [dBuV/m]	Limit [dBuV/m]	Margin [dB]	Remark
Hori	120.120	QP	32.5	13.0	8.3	32.1	21.7	43.5	21.8	
Hori	144.000	QP	30.6	14.7	8.5	32.1	21.7	43.5	21.8	
Hori	168.011	QP	32.1	15.7	8.8	32.1	24.5	43.5	19.0	
Hori	192.014	QP	38.4	16.4	9.0	32.1	31.7	43.5	11.8	
Hori	216.020	QP	42.2	16.8	9.2	32.1	36.1	46.0	9.9	
Hori	333.040	QP	38.5	15.4	10.1	32.0	32.0	46.0	14.0	
Hori	2483.500	PK	44.5	28.4	3.1	32.3	43.7	73.9	30.2	
Hori	4924.000	PK	NS	-	-	-	-	73.9	-	
Hori	7386.000	PK	NS	-	-	-	-	73.9	-	
Hori	9848.000	PK	NS	-	-	-	-	73.9	-	
Hori	2483.500	AV	37.5	28.4	3.1	32.3	36.7	53.9	17.2	
Hori	4924.000	AV	NS	-	-	-	-	53.9	-	
Hori	7386.000	AV	NS	-	-	-	-	53.9	-	
Hori	9848.000	AV	NS	-	-	-	-	53.9	-	
Vert	48.000	QP	43.9	11.6	7.3	32.1	30.7	40.0	9.3	
Vert	51.650	QP	41.9	10.4	7.4	32.1	27.6	40.0	12.4	
Vert	72.000	QP	47.5	6.5	7.7	32.2	29.5	40.0	10.5	
Vert	120.001	QP	43.4	13.0	8.3	32.1	32.6	43.5	10.9	
Vert	168.000	QP	35.8	15.7	8.8	32.1	28.2	43.5	15.3	
Vert	192.000	QP	38.6	16.4	9.0	32.1	31.9	43.5	11.6	
Vert	2483.500	PK	46.0	28.4	3.1	32.3	45.2	73.9	28.7	
Vert	4924.000	PK	NS	-	-	-	-	73.9	-	
Vert	7386.000	PK	NS	-	-	-	-	73.9	-	
Vert	9848.000	PK	NS	-	-	-	-	73.9	-	
Vert	2483.500	AV	37.3	28.4	3.1	32.3	36.5	53.9	17.4	
Vert	4924.000	AV	NS	-	-	-	-	53.9	-	
Vert	7386.000	AV	NS	-	-	-	-	53.9	-	
Vert	9848.000	AV	NS	-	-	-	-	53.9	-	

Result = Reading + Ant Factor + Loss (Cable+Attenuator+Filter-Distance factor(above 10GHz)) - Gain(Ant

\*Other frequency noises omitted in this report were not seen or had enough margin (more than 20dB).

\*NS: Not spurious emission detected

\*The 10th harmonic was not seen so the result was its base noise level.

Distance factor: 10GHz-26.5GHz 20log(3.0m/1.0m)= 9.5dB

**UL Japan, Inc.**

**Head Office EMC Lab.**

4383-326 Asama-cho, Ise-shi, Mie-ken 516-0021 JAPAN

Telephone : +81 596 24 8999

Facsimile : +81 596 24 8124

### Burst rate confirmation

Test place	Head Office EMC Lab. No.11 Measurement Room
Report No.	10180434H
Date	01/22/2014
Temperature/ Humidity	23 deg.C./ 58%
Engineer	Shinya Watanabe
Mode	11b Tx

#### 11b 11Mbps

<b>Tx on / (Tx on + Tx off) =</b>	<b>1.000</b>
<b>Tx on / (Tx on + Tx off) * 100 =</b>	<b>100.0 %</b>
<b>Duty factor = 10 * log (1 / 1) =</b>	<b>0.00 dB</b>

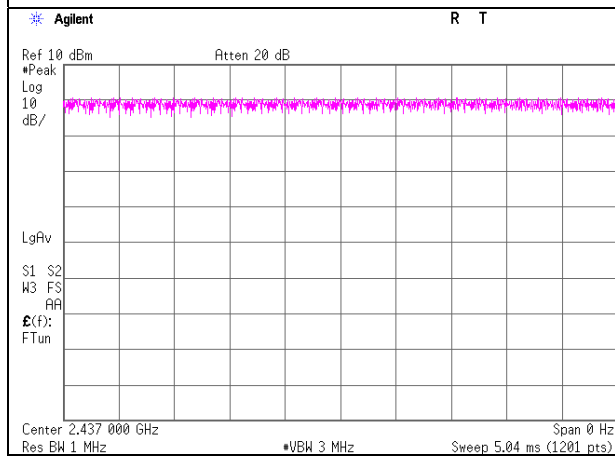

**UL Japan, Inc.**

**Head Office EMC Lab.**

4383-326 Asama-cho, Ise-shi, Mie-ken 516-0021 JAPAN

Telephone : +81 596 24 8999

Facsimile : +81 596 24 8124

### Conducted Spurious Emission

Test place	Head Office EMC Lab. No.11 Measurement Room
Report No.	10180434H
Date	01/22/2014
Temperature/ Humidity	23 deg.C/ 58%
Engineer	Shinya Watanabe
Mode	11b Tx

#### 11b Tx 2462MHz

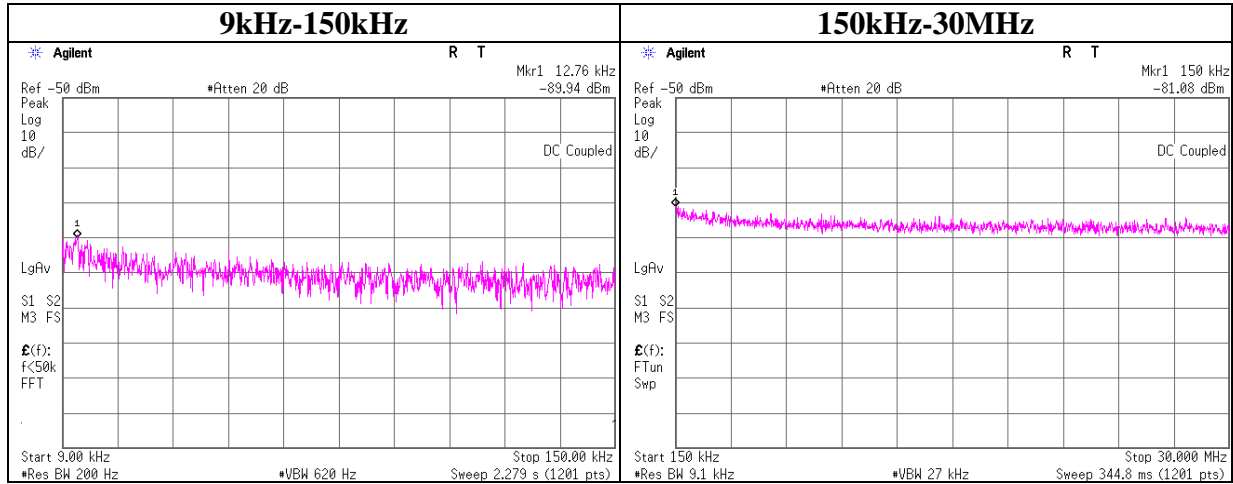

Frequency [kHz]	Reading [dBm]	Cable Loss [dB]	Attenuator [dB]	Antenna Gain [dBi]	EIRP [dBm]	Distance [m]	Ground bounce [dB]	E (field strength) [dBuV/m]	Limit [dBuV/m]
12.76	-89.9	0.75	10.1	2.1	-77.0	300.0	6.0	-15.8	45.5
150	-81.0	0.75	10.1	2.1	-68.1	300.0	6.0	-6.8	24.1

$E = \text{EIRP} - 20\log(D) + \text{Ground bounce} + 104.8 [\text{dBuV/m}]$

$\text{EIRP} = \text{Reading} + \text{Cable Loss} + \text{Attenuator} + \text{Antenna Gain}$

**UL Japan, Inc.**

**Head Office EMC Lab.**

4383-326 Asama-cho, Ise-shi, Mie-ken 516-0021 JAPAN

Telephone : +81 596 24 8999

Facsimile : +81 596 24 8124



### Power Density

Test place Head Office EMC Lab. No.11 Measurement Room  
Report No. 10180434H  
Date 01/22/2014  
Temperature/ Humidity 23 deg.C./ 58%  
Engineer Shinya Watanabe  
Mode 11b Tx

11b 11Mbps

Freq. [MHz]	Reading [dBm]	Cable Loss [dB]	Atten. [dB]	Result [dBm]	Limit [dBm]	Margin [dB]
2412.00	-20.25	0.75	10.07	-9.43	8.00	17.43
2437.00	-19.63	0.75	10.07	-8.81	8.00	16.81
2462.00	-19.17	0.75	10.07	-8.35	8.00	16.35

Sample Calculation:

Result = Reading + Cable Loss (including the cable(s) customer supplied) + Attenuator

---

**UL Japan, Inc.**

**Head Office EMC Lab.**

4383-326 Asama-cho, Ise-shi, Mie-ken 516-0021 JAPAN

Telephone : +81 596 24 8999

Facsimile : +81 596 24 8124

**Power Density**

**11b**

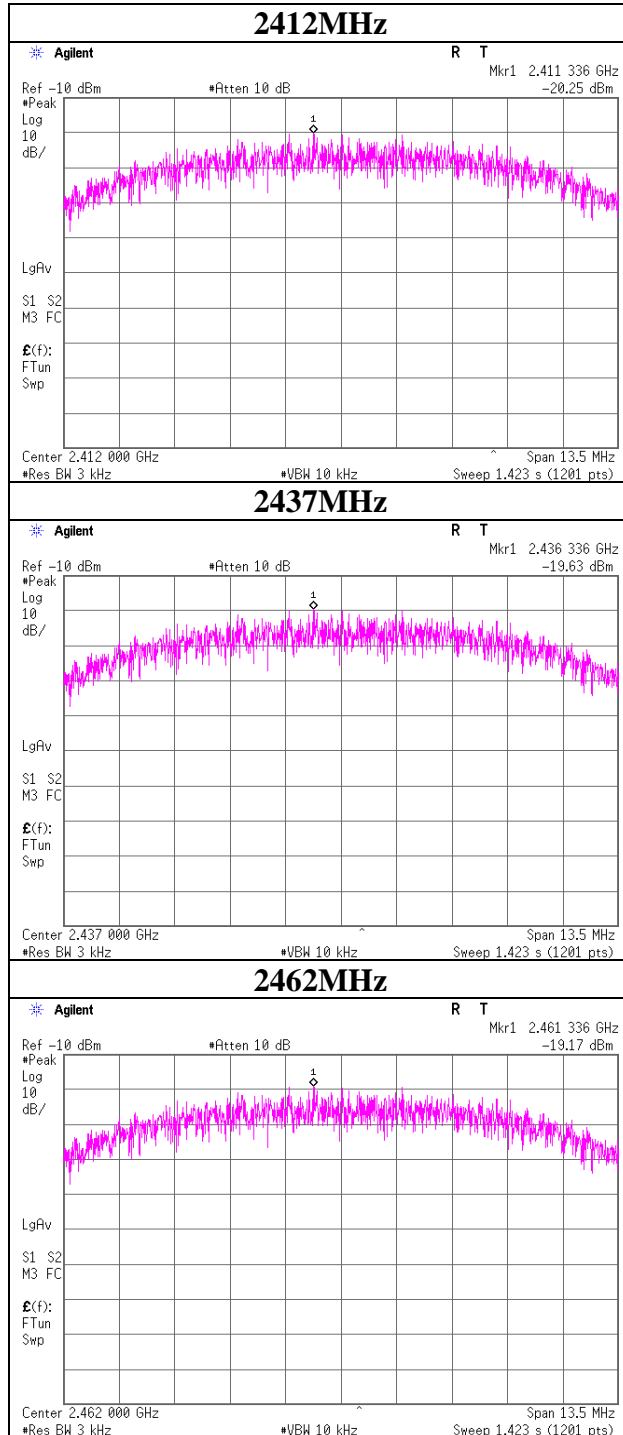

## 99%Occupied Bandwidth

Test place	Head Office EMC Lab. No.11 Measurement Room
Report No.	10180434H
Date	01/22/2014
Temperature/ Humidity	23 deg.C./ 58%
Engineer	Shinya Watanabe
Mode	11b Tx

### 11b

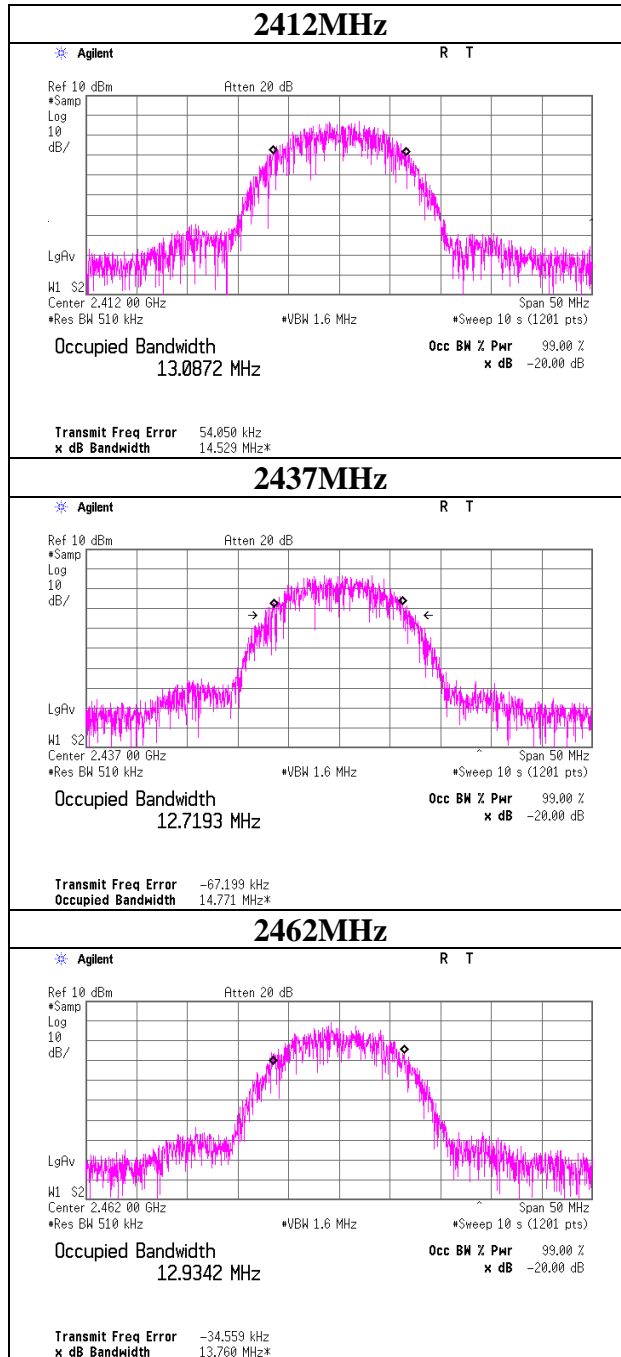

## APPENDIX 2: Test instruments

### EMI test equipment

Control No.	Instrument	Manufacturer	Model No	Serial No	Test Item	Calibration Date * Interval(month)
MAEC-03	Semi Anechoic Chamber(NSA)	TDK	Semi Anechoic Chamber 3m	DA-10005	RE	2013/02/28 * 12
MOS-13	Thermo-Hygrometer	Custom	CTH-180	-	RE	2013/02/26 * 12
MJM-16	Measure	KOMELON	KMC-36	-	RE	-
COTS-MEMI	EMI measurement program	TSJ	TEPTO-DV	-	RE/CE	-
MSA-05	Spectrum Analyzer	Advantest	R3273	160400285	RE	2013/11/08 * 12
MTR-08	Test Receiver	Rohde & Schwarz	ESCI	100767	RE	2013/08/20 * 12
MBA-03	Biconical Antenna	Schwarzbeck	BBA9106	1915	RE	2013/10/13 * 12
MLA-03	Logperiodic Antenna	Schwarzbeck	USLP9143	174	RE	2013/10/13 * 12
MCC-51	Coaxial cable	UL Japan	-	-	RE	2013/07/23 * 12
MAT-70	Attenuator(6dB)	Agilent	8491A-006	MY52460153	RE	2013/04/05 * 12
MPA-13	Pre Amplifier	SONOMA INSTRUMENT	310	260834	RE	2013/03/12 * 12
MHA-20	Horn Antenna 1-18GHz	Schwarzbeck	BBHA9120D	258	RE	2013/05/17 * 12
MCC-133	Microwave Cable	HUBER+SUHNER	SUCOFLEX104	336164/4(1m) / 340640(5m)	RE	2013/09/27 * 12
MPA-11	MicroWave System Amplifier	Agilent	83017A	MY39500779	RE	2013/03/12 * 12
MHA-16	Horn Antenna 15-40GHz	Schwarzbeck	BBHA9170	BBHA9170306	RE	2013/05/17 * 12
MHF-25	High Pass Filter 3.5-18.0GHz	UL Japan	HPF SELECTOR	001	RE	2013/09/01 * 12
MPM-08	Power Meter	Anritsu	ML2495A	6K00003338	AT	2013/10/15 * 12
MPSE-11	Power sensor	Anritsu	MA2411B	011737	AT	2013/10/15 * 12
MAT-20	Attenuator(10dB)(above 1GHz)	HIROSE ELECTRIC CO.,LTD.	AT-110	-	AT	2013/01/09 * 12
MBM-12	Barometer	Sunoh	SBR121	873	AT	2012/02/20 * 36
MOS-19	Thermo-Hygrometer	Custom	CTH-201	0001	AT	2013/12/17 * 12
MRENT-95	Spectrum Analyzer	Agilent	E4440A	MY46185823	AT	2013/06/14 * 12
MAEC-04	Semi Anechoic Chamber(NSA)	TDK	Semi Anechoic Chamber 3m	DA-10005	CE	2013/02/28 * 12
MOS-15	Thermo-Hygrometer	Custom	CTH-180	-	CE	2013/02/26 * 12
MJM-09	Measure	KDS	E19-55	-	CE	-
MTR-01	Test Receiver	Rohde & Schwarz	ESI40	100084	CE	2013/11/12 * 12
MLS-06	LISN(AMN)	Schwarzbeck	NSLK8127	8127363	CE(EUT)	2013/01/07 * 12
MLS-07	LISN(AMN)	Schwarzbeck	NSLK8127	8127364	CE(AE)	2013/01/07 * 12
MTA-28	Terminator	TME	CT-01	-	CE	2013/11/26 * 12
MAT-67	Attenuator	JFW Industries, Inc.	50FP-013H2 N	-	CE	2013/01/09 * 12
MCC-113	Coaxial cable	Fujikura/Suhner/TSJ	5D-2W(10m)/SFM141(5m)/421-010(1m)/suciform141-PE(1m)/RFM-E121(Switcher)	-/04178	CE	2013/07/23 * 12

**The expiration date of the calibration is the end of the expired month.**

**All equipment is calibrated with valid calibrations. Each measurement data is traceable to the national or international standards.**

**UL Japan, Inc.**

**Head Office EMC Lab.**

4383-326 Asama-cho, Ise-shi, Mie-ken 516-0021 JAPAN

Telephone : +81 596 24 8999

Facsimile : +81 596 24 8124

As for some calibrations performed after the tested dates, those test equipment have been controlled by means of an unbroken chains of calibrations.

Test Item: CE: Conducted Emission  
RE: Radiated Emission  
AT: Antenna Terminal Conducted test