

REUSED DATA TEST REPORT

FCC 47 CFR PART 15 SUBPART C

Test Standard	FCC Part 15.247
Product name	Communication module
Brand Name	muRata
Model No.	LBEE6XX1UR
Test Result	Pass
Statements of Conformity	Determination of compliance is based on the results of the compliance measurement, not taking into account measurement instrumentation uncertainty.

The test Result was tested by Compliance Certification Services Inc. The test data, data evaluation, test procedures, and equipment configurations shown in this report were given in ANSI C63.10: 2013 and compliance standards.

The test results of this report relate only to the tested sample (EUT) identified in this report.

The test Report of full or partial shall not copy. Without written approval of Compliance Certification Services Inc. (Wugu Laboratory).

Approved by:



Shawn Wu
Supervisor

Unless otherwise stated the results shown in this test report refer only to the sample(s) tested and such sample(s) are retained for 90 days only.
除非另有說明，此報告結果僅對測試之樣品負責，同時此樣品僅保留90天。本報告未經本公司書面許可，不可部份複製。

This document is issued by the Company subject to its General Conditions of Service printed overleaf, available on request or accessible at <http://www.sgs.com.tw/Terms-and-Conditions> and, for electronic format documents, subject to Terms and Conditions for Electronic Documents at <http://www.sgs.com.tw/Terms-and-Conditions>. Attention is drawn to the limitation of liability, indemnification and jurisdiction issues defined therein. Any holder of this document is advised that information contained hereon reflects the Company's findings at the time of its intervention only and within the limits of client's instruction, if any. The Company's sole responsibility is to its Client and this document does not exonerate parties to a transaction from exercising all their rights and obligations under the transaction documents. This document cannot be reproduced, except in full, without prior written approval of the Company. Any unauthorized alteration, forgery or falsification of the content or appearance of this document is unlawful and offenders may be prosecuted to the fullest extent of the law.

Revision History

Rev.	Issue Date	Revisions	Effect Page	Revised By
00	May 16, 2024	Initial Issue	ALL	Allison Chen
01	May 28, 2024	See the following Note Rev.(01)	P.4	Allison Chen

Note:**Rev.(01)**

1. Modify applicant's and manufacturer's name and address.

Table of contents

1.	GENERAL INFORMATION.....	4
1.1	EUT INFORMATION.....	4
1.2	EUT CHANNEL INFORMATION.....	5
1.3	ANTENNA INFORMATION.....	6
1.4	MEASUREMENT UNCERTAINTY.....	7
1.5	FACILITIES AND TEST LOCATION.....	8
1.6	INSTRUMENT CALIBRATION.....	9
1.7	SUPPORT AND EUT ACCESSORIES EQUIPMENT.....	10
1.8	TEST SETUP DIAGRAM.....	10
1.9	TEST METHODOLOGY AND APPLIED STANDARDS.....	10
2.	TEST SUMMARY.....	11
3.	DESCRIPTION OF TEST MODES.....	12
3.1	THE WORST MODE OF OPERATING CONDITION.....	12
3.2	THE WORST MODE OF MEASUREMENT.....	14
4.	TEST RESULT.....	15
4.1	RADIATION BANDEDGE AND SPURIOUS EMISSION.....	15
4.2	TEST DATA RE-USE SUMMARY.....	44
	APPENDIX 1 - PHOTOGRAPHS OF EUT	

1. GENERAL INFORMATION

1.1 EUT INFORMATION

Applicant	Murata Manufacturing Co., Ltd. 10-1, Higashikotari 1-chome, Nagaokakyo-shi, Kyoto 617-8555 Japan
Manufacturer	Murata Manufacturing Co., Ltd. 1-10-1, Higashikotari, Nagaokakyo-shi, Kyoto 617-8555 Japan
Equipment	Communication module
Model Name	LBEE6XX1UR
Model Discrepancy	N/A
Brand Name	muRata
Received Date	March 12, 2024
Date of Test	April 8~26, 2024
Power Supply	Powered from power supply: DC 3.3V
HW Version	1.0
SW Version	1.1.1.2

Remark:

1. For more details, please refer to the User's manual of the EUT.
2. Disclaimer: Antenna information is provided by the applicant, test results of this report are applicable to the sample EUT received.

1.2 EUT CHANNEL INFORMATION

Bluetooth:

Frequency Range	2402MHz-2480MHz
Modulation Type	1. GFSK for BDR-1Mbps 2. $\pi/4$ -DQPSK for EDR-2Mbps 3. 8DPSK for EDR-3Mbps
Number of channel	79 Channels

WIFI 5GHz

Frequency Range	UNII-1	
	IEEE 802.11a	5180 ~ 5240 MHz
	IEEE 802.11n HT20	5180 ~ 5240 MHz
	IEEE 802.11ac VHT20	5180 ~ 5240 MHz
	IEEE 802.11n HT40	5190 ~ 5230 MHz
	IEEE 802.11ac VHT40	5190 ~ 5230 MHz
	IEEE 802.11ac VHT80	5210 MHz
	UNII-2a	
	IEEE 802.11a	5260 ~ 5320 MHz
	IEEE 802.11n HT20	5260 ~ 5320 MHz
	IEEE 802.11ac VHT20	5260 ~ 5320 MHz
	IEEE 802.11n HT40	5270 ~ 5310 MHz
	IEEE 802.11ac VHT40	5270 ~ 5310 MHz
	IEEE 802.11ac VHT80	5290 MHz
	UNII-2c	
	IEEE 802.11a	5500 ~ 5720 MHz
	IEEE 802.11n HT20	5500 ~ 5720 MHz
	IEEE 802.11ac VHT20	5500 ~ 5720 MHz
	IEEE 802.11n HT40	5510 ~ 5710 MHz
	IEEE 802.11ac VHT40	5510 ~ 5710 MHz
	IEEE 802.11ac VHT80	5530 ~ 5690 MHz
UNII-3		
IEEE 802.11a	5745 ~ 5825 MHz	
IEEE 802.11n HT20	5745 ~ 5825 MHz	
IEEE 802.11ac VHT20	5745 ~ 5825 MHz	
IEEE 802.11n HT40	5755 ~ 5795 MHz	
IEEE 802.11ac VHT40	5755 ~ 5795 MHz	
IEEE 802.11ac VHT80	5775 MHz	
Modulation Type	1. IEEE 802.11a mode: OFDM 2. IEEE 802.11n HT20 mode: OFDM 3. IEEE 802.11n HT40 mode: OFDM 4. IEEE 802.11ac VHT20 mode: OFDM 5. IEEE 802.11ac VHT40 mode: OFDM 6. IEEE 802.11ac VHT80 mode: OFDM	

Remark:

1. Refer as ANSI C63.10: 2013 clause 5.6.1 Table 4 for test channels

Refer as ANSI C63.10: 2013 clause 5.6.1 Table 4 for test channels

Number of frequencies to be tested		
Frequency range in which device operates	Number of frequencies	Location in frequency range of operation
<input type="checkbox"/> 1 MHz or less	1	Middle
<input type="checkbox"/> 1 MHz to 10 MHz	2	1 near top and 1 near bottom
<input checked="" type="checkbox"/> More than 10 MHz	3	1 near top, 1 near middle, and 1 near bottom

1.3 ANTENNA INFORMATION

Bluetooth:

Antenna Type	<input type="checkbox"/> PIFA <input checked="" type="checkbox"/> PCB <input type="checkbox"/> Dipole <input type="checkbox"/> Coils <input type="checkbox"/> Other: Chip
Antenna Gain	Gain: 1 dBi
Brand / Model	Forvia / BT_IFA
Antenna Connector	N/A

WIFI 5GHz:

Antenna Type	<input type="checkbox"/> PIFA <input type="checkbox"/> PCB <input type="checkbox"/> Dipole <input type="checkbox"/> Coils <input checked="" type="checkbox"/> Other: Chip
Antenna Gain	Gain: 1.7 dBi
Brand / Model	INPAQ TECHNOLOGY / VGAP-CLB-AS-A1
Antenna Connector	N/A

Notes:

1. The antenna(s) of the EUT are permanently attached and there are no provisions for connection to an external antenna. So the EUT complies with the requirements of §15.203.

1.4 MEASUREMENT UNCERTAINTY

PARAMETER	UNCERTAINTY
AC Powerline Conducted Emission	± 2.213 dB
Channel Bandwidth	± 2.7 %
RF output power (Power Meter + Power sensor)	± 0.243 dB
Power Spectral density	± 2.739 dB
Conducted Bandedge	± 2.739 dB
Conducted Spurious Emission	± 2.742 dB
Radiated Emission_9kHz-30MHz	± 3.761 dB
Radiated Emission_30MHz-200MHz	± 3.473 dB
Radiated Emission_200MHz-1GHz	± 3.946 dB
Radiated Emission_1GHz-6GHz	± 4.797 dB
Radiated Emission_6GHz-18GHz	± 4.803 dB
Radiated Emission_18GHz-26GHz	± 3.459 dB
Radiated Emission_26GHz-40GHz	± 3.297 dB

Remark:

- 1.This uncertainty represents an expanded uncertainty expressed at approximately the 95% confidence level using a coverage factor of k=2
2. ISO/IEC 17025 requires that an estimate of the measurement uncertainties associated with the emissions test results be included in the report.

1.5 FACILITIES AND TEST LOCATION

All measurement facilities used to collect the measurement data are located at

AC Powerline Conducted Emission and Conducted:

No.11, Wugong 6th Rd., Wugu Dist., New Taipei City, Taiwan.

Radiated emission 9kHz to 40GHz:

No.11, Wugong 6th Rd., Wugu Dist., New Taipei City, Taiwan.

CAB identifier: TW1309

Test site	Test Engineer	Remark
AC Conduction Room	N/A	Not applicable.
Radiation	Ray Li	-
RF Conducted	N/A	Not applicable.

Remark: The lab has been recognized as the FCC accredited lab. under the KDB 974614 D01 and is listed in the FCC public Access Link (PAL) database, FCC Registration No. :444940, the FCC Designation No.:TW1309

1.6 INSTRUMENT CALIBRATION

966A_Radiated					
Name of Equipment	Manufacturer	Model	Serial Number	Calibration Date	Calibration Due
Signal Analyzer	KEYSIGHT	N9010A	MY54200716	2023-10-13	2024-10-12
Thermo-Hygro Meter	WISEWIND	1206	D07	2023-12-08	2024-12-07
Horn Antenna	ETC	MCTD 1209	DRH13M02003	2023-12-28	2024-12-27
Preamplifier	HP	8449B	3008A00965	2023-12-22	2024-12-21
Cable	EMCI	EMC101G	221213+221011 +221012	2023-10-17	2024-10-16
Attenuator	Mini-Circuits	BW-S9W5	BWS9W5-09- 966A-01	2024-02-07	2025-02-06
Horn Antenna	SCHWARZBECK	BBHA9170	1047	2023-12-13	2024-12-12
High Pass Filters	Titan Microwave	T04H30001800 070S01	22011402-4	2023-06-17	2024-06-16
Pre-Amplifier	EMCI	EMC184045SE	980860	2023-12-12	2024-12-11
Turn Table	CCS	CC-T-1F	N/A	N.C.R	N.C.R
Controller	CCS	CC-C-1F	N/A	N.C.R	N.C.R
Antenna Tower	CCS	CC-A-1F	N/A	N.C.R	N.C.R
Site Validation	CCS	966A	N/A	2023-07-10	2024-07-09
Software	e3 V9-210616c				

Remark:

1. Each piece of equipment is scheduled for calibration once a year.
2. N.C.R. = No Calibration Required.

1.7 SUPPORT AND EUT ACCESSORIES EQUIPMENT

Support Unit List						Remark
Name of Equipment	Manufacturer	Model	Serial Number	Calibration Date	Calibration Due	
NB(D)	Lenovo	ThinkPad X260	N/A	N/A	N/A	1
Adapter	Lenovo	ADLX45DLC3A	N/A	N/A	N/A	2
Power Supply	GW	GPC-3030D	8070184	2023-10-02	2024-10-01	3
Power Cable	N/A	N/A	N/A	N/A	N/A	A
Power Cable For Control Board	N/A	N/A	N/A	N/A	N/A	B
Sub Board	N/A	N/A	N/A	N/A	N/A	C
Flat Cable	N/A	N/A	N/A	N/A	N/A	D
Armadillo(w Motherboard)	N/A	N/A	N/A	N/A	N/A	E
RS252C Cable	iBUFFALO	NA	A80122	N/A	N/A	F
USB-Serial Cable	N/A	N/A	N/A	N/A	N/A	G
USB Cable	ELECOM	N/A	B0119I051Z N99	N/A	N/A	H

1.8 TEST SETUP DIAGRAM

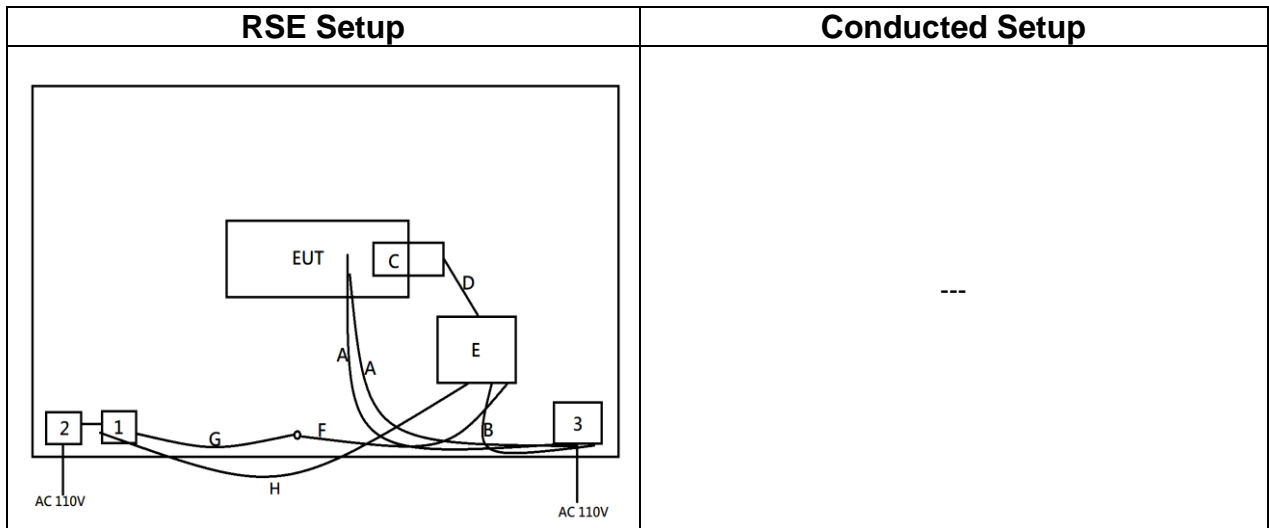

1.9 TEST METHODOLOGY AND APPLIED STANDARDS

The test methodology, setups and results comply with all requirements in accordance with ANSI C63.10:2013, FCC Part 2, FCC Part 15.247 and KDB 558074 D01.

2. TEST SUMMARY

FCC Standard Section	Report Section	Test Item	Result
15.203	1.3	Antenna Requirement	Pass
15.247(d) 15.205 15.209	4.1	Radiation Spurious Emission	Pass

3. DESCRIPTION OF TEST MODES

3.1 THE WORST MODE OF OPERATING CONDITION

Bluetooth

Operation mode	GFSK for BDR-1Mbps (DH5) $\pi/4$ -DQPSK for 2Mbps (2DH5) 8DPSK for EDR-3Mbps (3DH5)
Test Channel Frequencies	<p>GFSK for BDR-1Mbps: 1.Lowest Channel: 2402MHz 2.Middle Channel: 2441MHz 3.Highest Channel: 2480MHz</p> <p>$\pi/4$-DQPSK for 2Mbps: 1.Lowest Channel: 2402MHz 2.Middle Channel: 2441MHz 3.Highest Channel: 2480MHz</p> <p>8DPSK for EDR-3Mbps: 1.Lowest Channel: 2402MHz 2.Middle Channel: 2441MHz 3.Highest Channel: 2480MHz</p>

Remark:

1. EUT pre-scanned data rate of output power for each mode, the worst data rate were recorded in this report.

WIFI 5GHz

Operation mode	1. IEEE 802.11a mode: 6Mbps 2. IEEE 802.11n HT20 mode: MCS0 3. IEEE 802.11n HT40 mode: MCS0 4. IEEE 802.11ac VHT20 mode: MCS0 5. IEEE 802.11ac VHT40 mode: MCS0 6. IEEE 802.11ac VHT80 mode: MCS0																																																							
Operating Frequency Range	<table border="1"> <thead> <tr> <th></th> <th>Mode</th> <th>Frequency Range (MHz)</th> </tr> </thead> <tbody> <tr> <td rowspan="6">U-NII-1</td> <td>IEEE 802.11a</td> <td>5180, 5220, 5240</td> </tr> <tr> <td>IEEE 802.11n HT20</td> <td>5180, 5220, 5240</td> </tr> <tr> <td>IEEE 802.11n HT40</td> <td>5190, 5230</td> </tr> <tr> <td>IEEE 802.11ac VHT20</td> <td>5180, 5220, 5240</td> </tr> <tr> <td>IEEE 802.11ac VHT40</td> <td>5190, 5230</td> </tr> <tr> <td>IEEE 802.11ac VHT80</td> <td>5210</td> </tr> <tr> <td rowspan="6">U-NII-2a</td> <td>IEEE 802.11a</td> <td>5260, 5300, 5320</td> </tr> <tr> <td>IEEE 802.11n HT20</td> <td>5260, 5300, 5320</td> </tr> <tr> <td>IEEE 802.11n HT40</td> <td>5270, 5310</td> </tr> <tr> <td>IEEE 802.11ac VHT20</td> <td>5260, 5300, 5320</td> </tr> <tr> <td>IEEE 802.11ac VHT40</td> <td>5270, 5310</td> </tr> <tr> <td>IEEE 802.11ac VHT80</td> <td>5290</td> </tr> <tr> <td rowspan="6">U-NII-2c</td> <td>IEEE 802.11a</td> <td>5500, 5580, 5700, 5720</td> </tr> <tr> <td>IEEE 802.11n HT20</td> <td>5500, 5580, 5700, 5720</td> </tr> <tr> <td>IEEE 802.11n HT40</td> <td>5510, 5550, 5670, 5710</td> </tr> <tr> <td>IEEE 802.11ac VHT20</td> <td>5500, 5580, 5700, 5720</td> </tr> <tr> <td>IEEE 802.11ac VHT40</td> <td>5510, 5550, 5670, 5710</td> </tr> <tr> <td>IEEE 802.11ac VHT80</td> <td>5530, 5610, 5690</td> </tr> <tr> <td rowspan="6">U-NII-3</td> <td>IEEE 802.11a</td> <td>5745, 5785, 5825</td> </tr> <tr> <td>IEEE 802.11n HT20</td> <td>5745, 5785, 5825</td> </tr> <tr> <td>IEEE 802.11n HT40</td> <td>5755, 5795</td> </tr> <tr> <td>IEEE 802.11ac VHT20</td> <td>5745, 5785, 5825</td> </tr> <tr> <td>IEEE 802.11ac VHT40</td> <td>5755, 5795</td> </tr> <tr> <td>IEEE 802.11ac VHT80</td> <td>5775</td> </tr> </tbody> </table>		Mode	Frequency Range (MHz)	U-NII-1	IEEE 802.11a	5180, 5220, 5240	IEEE 802.11n HT20	5180, 5220, 5240	IEEE 802.11n HT40	5190, 5230	IEEE 802.11ac VHT20	5180, 5220, 5240	IEEE 802.11ac VHT40	5190, 5230	IEEE 802.11ac VHT80	5210	U-NII-2a	IEEE 802.11a	5260, 5300, 5320	IEEE 802.11n HT20	5260, 5300, 5320	IEEE 802.11n HT40	5270, 5310	IEEE 802.11ac VHT20	5260, 5300, 5320	IEEE 802.11ac VHT40	5270, 5310	IEEE 802.11ac VHT80	5290	U-NII-2c	IEEE 802.11a	5500, 5580, 5700, 5720	IEEE 802.11n HT20	5500, 5580, 5700, 5720	IEEE 802.11n HT40	5510, 5550, 5670, 5710	IEEE 802.11ac VHT20	5500, 5580, 5700, 5720	IEEE 802.11ac VHT40	5510, 5550, 5670, 5710	IEEE 802.11ac VHT80	5530, 5610, 5690	U-NII-3	IEEE 802.11a	5745, 5785, 5825	IEEE 802.11n HT20	5745, 5785, 5825	IEEE 802.11n HT40	5755, 5795	IEEE 802.11ac VHT20	5745, 5785, 5825	IEEE 802.11ac VHT40	5755, 5795	IEEE 802.11ac VHT80	5775
	Mode	Frequency Range (MHz)																																																						
U-NII-1	IEEE 802.11a	5180, 5220, 5240																																																						
	IEEE 802.11n HT20	5180, 5220, 5240																																																						
	IEEE 802.11n HT40	5190, 5230																																																						
	IEEE 802.11ac VHT20	5180, 5220, 5240																																																						
	IEEE 802.11ac VHT40	5190, 5230																																																						
	IEEE 802.11ac VHT80	5210																																																						
U-NII-2a	IEEE 802.11a	5260, 5300, 5320																																																						
	IEEE 802.11n HT20	5260, 5300, 5320																																																						
	IEEE 802.11n HT40	5270, 5310																																																						
	IEEE 802.11ac VHT20	5260, 5300, 5320																																																						
	IEEE 802.11ac VHT40	5270, 5310																																																						
	IEEE 802.11ac VHT80	5290																																																						
U-NII-2c	IEEE 802.11a	5500, 5580, 5700, 5720																																																						
	IEEE 802.11n HT20	5500, 5580, 5700, 5720																																																						
	IEEE 802.11n HT40	5510, 5550, 5670, 5710																																																						
	IEEE 802.11ac VHT20	5500, 5580, 5700, 5720																																																						
	IEEE 802.11ac VHT40	5510, 5550, 5670, 5710																																																						
	IEEE 802.11ac VHT80	5530, 5610, 5690																																																						
U-NII-3	IEEE 802.11a	5745, 5785, 5825																																																						
	IEEE 802.11n HT20	5745, 5785, 5825																																																						
	IEEE 802.11n HT40	5755, 5795																																																						
	IEEE 802.11ac VHT20	5745, 5785, 5825																																																						
	IEEE 802.11ac VHT40	5755, 5795																																																						
	IEEE 802.11ac VHT80	5775																																																						

Remark:

1. EUT pre-scanned data rate of output power for each mode, the worst data rate were recorded in this report.
2. For Canada the EUT Frequency Range 5600~5650MHz will be disabled.

3.2 THE WORST MODE OF MEASUREMENT

Radiated Emission Measurement Above 1G	
Test Condition	Radiated Emission Above 1G
Power supply Mode	Mode 1: EUT power by Power supply
Worst Mode	<input checked="" type="checkbox"/> Mode 1 <input type="checkbox"/> Mode 2 <input type="checkbox"/> Mode 3 <input type="checkbox"/> Mode 4
Worst Position	<input type="checkbox"/> Placed in fixed position. <input checked="" type="checkbox"/> Placed in fixed position at X-Plane (E2-Plane) <input type="checkbox"/> Placed in fixed position at Y-Plane (E1-Plane) <input type="checkbox"/> Placed in fixed position at Z-Plane (H-Plane)

Remark:

1. The worst mode was record in this test report.
2. EUT pre-scanned in three axis ,X,Y, Z and two polarity, for radiated measurement. The worst case(X-Plane) were recorded in this report

4. TEST RESULT

4.1 RADIATION BANDEDGE AND SPURIOUS EMISSION

4.1.1 Test Limit

FCC according to §15.247(d), §15.209 and §15.205,

In any 100 kHz bandwidth outside the authorized frequency band, all harmonic and spurious must be least 20 dB below the highest emission level with the authorized frequency band. Radiation emission which fall in the restricted bands must also follow the FCC section 15.209 as below limit in table.

Below 30 MHz

Frequency	Field Strength (microvolts/m)	Magnetic H-Field (microamperes/m)	Measurement Distance (metres)
9-490 kHz	2,400/F (F in kHz)	2,400/F (F in kHz)	300
490-1,705 kHz	24,000/F (F in kHz)	24,000/F (F in kHz)	30
1.705-30 MHz	30	N/A	30

Above 30 MHz

Frequency	Field Strength (microvolts/m)	Measurement Distance (metres)
30-88	100	3
88-216	150	3
216-960	200	3
Above 960	500	3

Remark:

Although these tests were performed other than open area test site, adequate comparison measurements were confirmed against 30 m open are test site. Therefore sufficient tests were made to demonstrate that the alternative site produces results that correlate with the ones of tests made in an open field based on KDB 414788.

UNII-1 :

For transmitters operating in the band 5150-5250 MHz, all emissions outside the band 5150-5350 MHz shall not exceed -27 dBm/MHz e.i.r.p. However, any unwanted emissions that fall into the band 5250-5350 MHz must be 26 dBc, when measured using a resolution bandwidth between 1 and 5% of the occupied bandwidth, above 5.25 GHz. Otherwise, the transmission is considered as intentional and the devices shall implement dynamic frequency selection (DFS) and transmitter power control (TPC) as per the requirements for the band 5250-5350 MHz

UNII-2a and 2c :

For devices with operating frequencies in the band 5250-5350 MHz but having a channel bandwidth that overlaps the band 5150-5250 MHz, the devices' unwanted emission shall not exceed -27 dBm/MHz e.i.r.p. outside the band 5150-5350 MHz and its power shall comply with the spectral power density for operation within the band 5150-5250 MHz. The device shall be labelled "for indoor use only." Emissions outside the band 5470-5725 MHz shall not exceed -27 dBm/MHz e.i.r.p.

UNII-3:

For the band 5725-5850 MHz, emissions at frequencies from the band edges to 10 MHz above or below the band edges shall not exceed -17 dBm/MHz e.i.r.p.

For emissions at frequencies more than 10 MHz above or below the band edges, the emissions power shall not exceed -27 dBm/MHz

4.1.2 Test Procedure

Test method Refer as ANSI C63.10:2013.

1. The EUT is placed on a turntable, Above 1 GHz is 1.5m and below 1 GHz is 0.8m above ground plane. The EUT Configured un accordance with ANSI C63.10: 2013, and the EUT set in a continuous mode.

2. The turntable shall be rotated for 360 degrees to determine the position of maximum emission level. And EUT is set 3m away from the receiving antenna, which is scanned from 1m to 4m above the ground plane to find out the highest emissions. Measurement are made polarized in both the vertical and the horizontal positions with antenna.

3. Span shall wide enough to full capture the emission measured. The SA from 9kHz to 26.5GHz set to the low, Mid and High channels with the EUT transmit.

Note: No emission found between lowest internal used/generated frequency to 30MHz (9KHz~30MHz)

Remark:

Although these tests were performed other than open area test site, adequate comparison measurements were confirmed against 30 m open are test site. Therefore sufficient tests were made to demonstrate that the alternative site produces results that correlate with the ones of tests made in an open field based on KDB 414788.

4. The SA setting following :

(1) Below 1G : RBW = 100kHz, VBW \geq 3 RBW, Sweep = Auto, Detector = Peak, Trace = Max hold.

(2) Above 1G :

(2.1) For Peak measurement : RBW = 1MHz, VBW \geq 3 RBW, Sweep = Auto, Detector = Peak, Trace = Max hold.

(2.2) For Average measurement : RBW = 1MHz, VBW

·If Duty Cycle \geq 98%, VBW=10Hz.

·If Duty Cycle < 98%, VBW=1/T.

5. Data result :

Actual FS=Spectrum Reading Level + Factor

Margin=Actual FS- Limit

4.1.3 Test Setup

9kHz ~ 30MHz

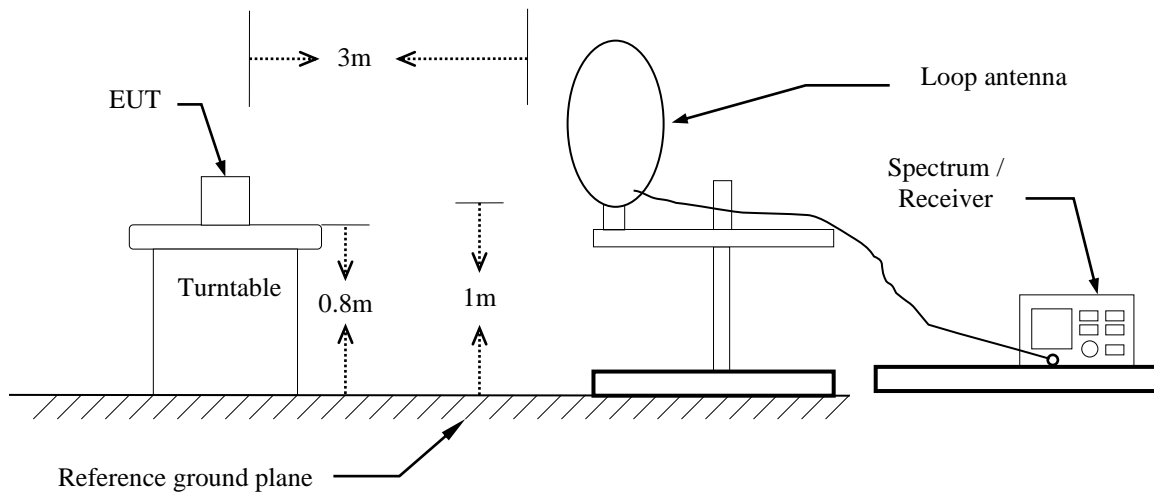

30MHz ~ 1GHz

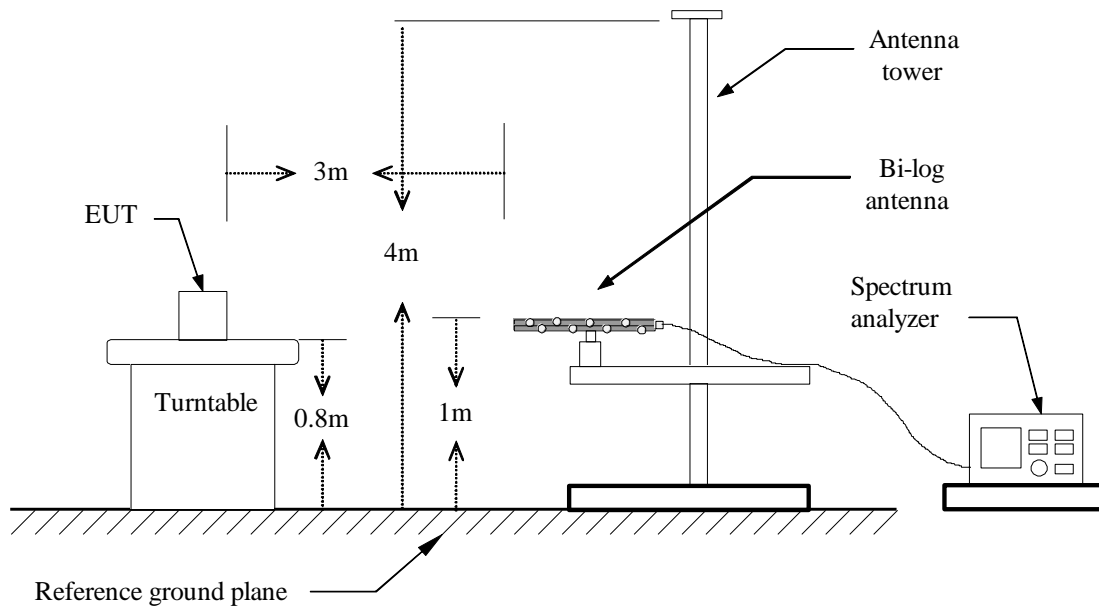

Above 1 GHz

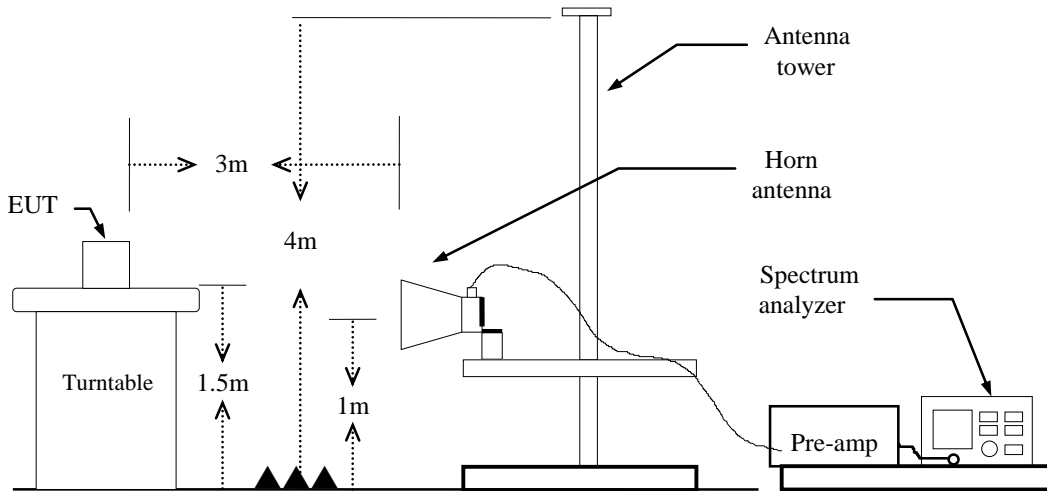

4.1.4 Test Result

Band Edge Test Data (Bluetooth)

Project No	:TM-2403000180P	Test Date	:2024-04-24
Operation Band	:BT BR	Temp./Humi.	:24.4/61
Frequency	:2480 MHz	Antenna Pol.	:Vertical
Operation Mode	:Bandedge	Engineer	:Tony.Chao
EUT Pol	:E1	Test Chamber	: 966A
Setting	:		

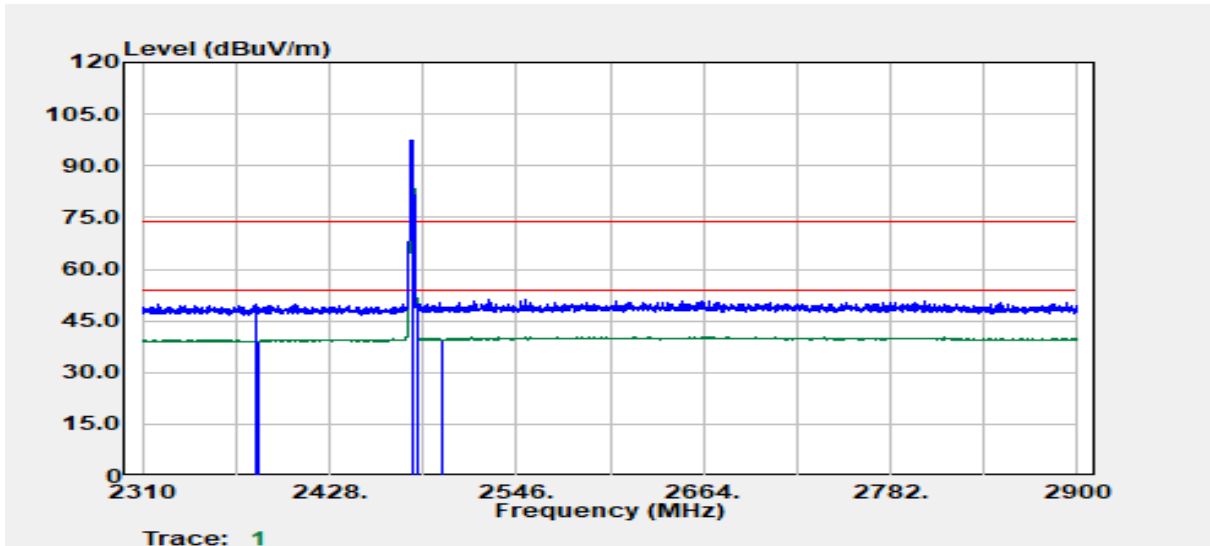

Freq. MHz	Detector Mode PK/QP/AV	Spectrum Read Level dB μ V	Factor dB	Actual FS dB μ V/m	Limit dB μ V/m	Margin dB
2381.91	Peak	43.65	6.11	49.76	74.00	-24.24
2382.91	Average	32.84	6.13	38.97	54.00	-15.03
2480.00	Peak	90.71	6.67	97.38	--	--
2480.00	Average	90.56	6.67	97.23	--	--
2483.53	Peak	41.47	6.71	48.18	74.00	-25.82
2498.51	Average	32.57	6.83	39.40	54.00	-14.60

Report No.: TMWK2403000680KR

Rev.: 01

Project No :TM-2403000180P
 Operation Band :BT BR
 Frequency :2480 MHz
 Operation Mode :Bandedge
 EUT Pol :E1
 Setting :

Test Date :2024-04-24
 Temp./Humi. :24.4/61
 Antenna Pol. :HORIZONTAL
 Engineer :Tony.Chao
 Test Chamber : 966A

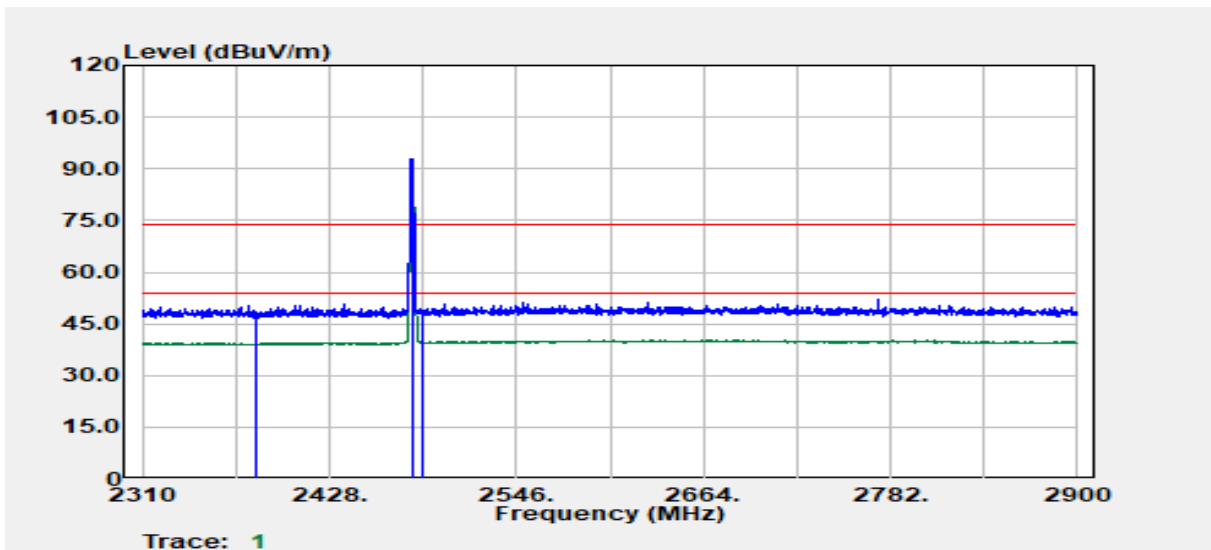

Freq. MHz	Detector Mode PK/QP/AV	Spectrum Read Level dB μ V	Factor dB	Actual FS dB μ V/m	Limit dB μ V/m	Margin dB
2381.41	Average	32.78	6.10	38.88	54.00	-15.12
2381.91	Peak	41.70	6.11	47.81	74.00	-26.19
2480.00	Peak	86.16	6.67	92.83	--	--
2480.00	Average	86.01	6.67	92.67	--	--
2487.03	Peak	41.23	6.76	47.99	74.00	-26.01
2487.52	Average	32.59	6.77	39.36	54.00	-14.64

Report No.: TMWK2403000680KR

Rev.: 01

Project No	:TM-2403000180P	Test Date	:2024-04-24
Operation Band	:BT EDR	Temp./Humi.	:24.4/61
Frequency	:2480 MHz	Antenna Pol.	:VERTICAL
Operation Mode	:Bandedge	Engineer	:Tony.Chao
EUT Pol	:E1	Test Chamber	: 966A
Setting	:		

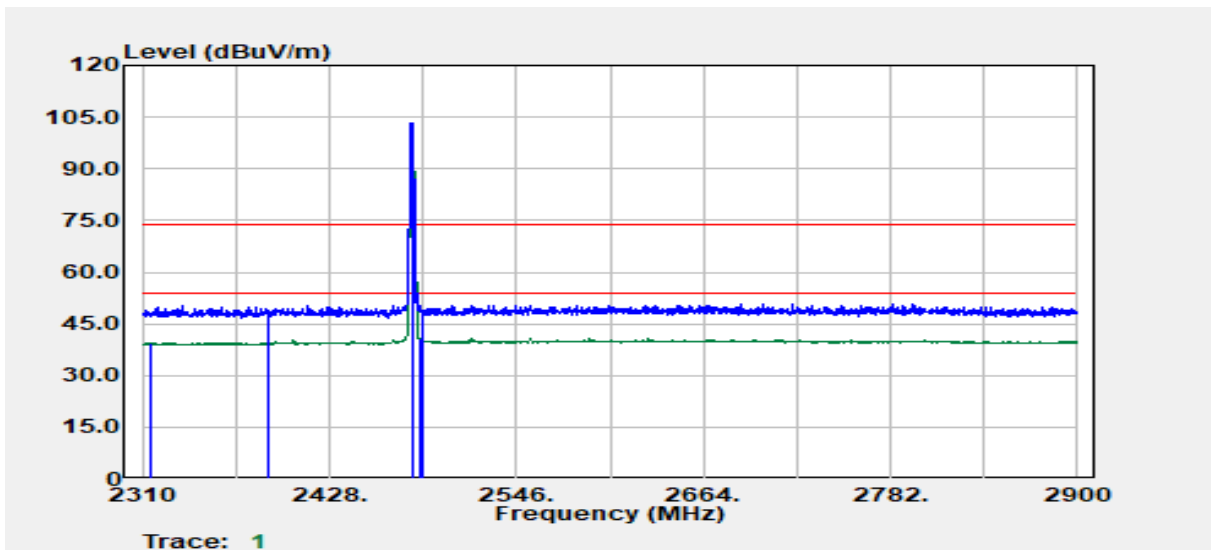

Freq. MHz	Detector Mode PK/QP/AV	Spectrum Read Level dB μ V	Factor dB	Actual FS dB μ V/m	Limit dB μ V/m	Margin dB
2314.99	Average	33.27	6.14	39.41	54.00	-14.59
2389.90	Peak	42.15	6.28	48.43	74.00	-25.57
2480.00	Peak	96.46	6.67	103.13	--	--
2480.00	Average	96.33	6.67	102.99	--	--
2484.53	Average	33.92	6.73	40.65	54.00	-13.35
2486.78	Peak	41.64	6.76	48.40	74.00	-25.60

Report No.: TMWK2403000680KR

Rev.: 01

Project No :TM-2403000180P
 Operation Band :BT EDR
 Frequency :2480 MHz
 Operation Mode :Bandedge
 EUT Pol :E1
 Setting :

Test Date :2024-04-24
 Temp./Humi. :24.4/61
 Antenna Pol. :HORIZONTAL
 Engineer :Tony.Chao
 Test Chamber : 966A

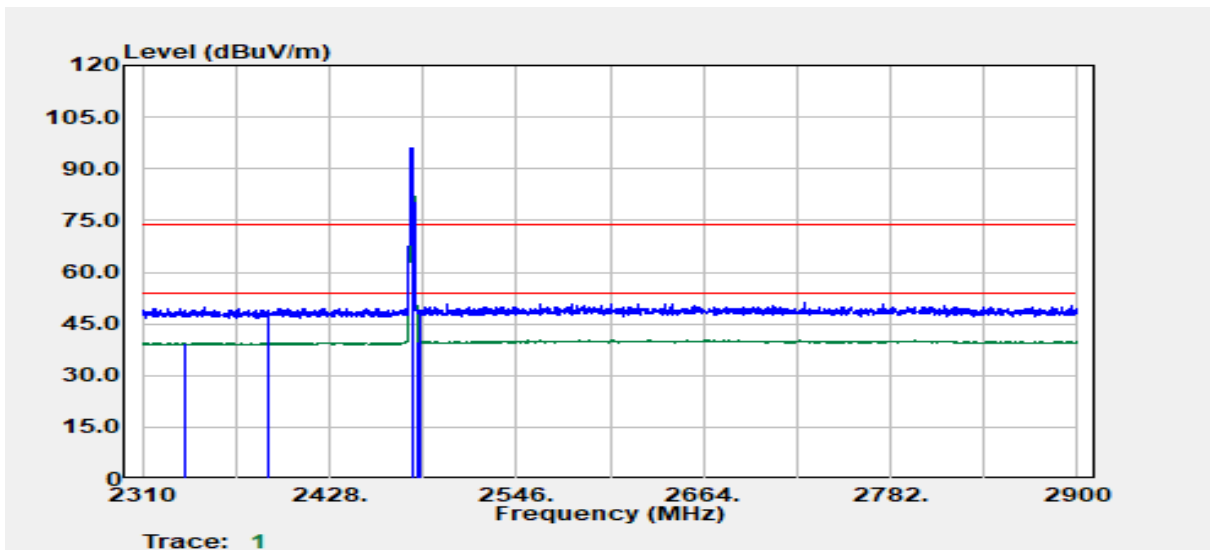

Freq. MHz	Detector Mode PK/QP/AV	Spectrum Read Level d μ V	Factor dB	Actual FS d μ V/m	Limit d μ V/m	Margin dB
2336.22	Average	33.26	6.14	39.40	54.00	-14.60
2389.40	Peak	42.01	6.27	48.28	74.00	-25.72
2480.00	Peak	89.34	6.67	96.00	--	--
2480.00	Average	89.18	6.67	95.85	--	--
2484.03	Average	33.17	6.72	39.89	54.00	-14.11
2485.03	Peak	41.53	6.73	48.26	74.00	-25.74

TX Test Data (Bluetooth)

Project No	:TM-2403000180P	Test Date	:2024-04-08
Operation Band	:BT BR	Temp./Humi.	:24.4/60
Frequency	:2480 MHz	Antenna Pol.	:Vertical
Operation Mode	:TX	Engineer	:Ray.Li
EUT Pol	:E2	Test Chamber	: 966A
Setting	:		

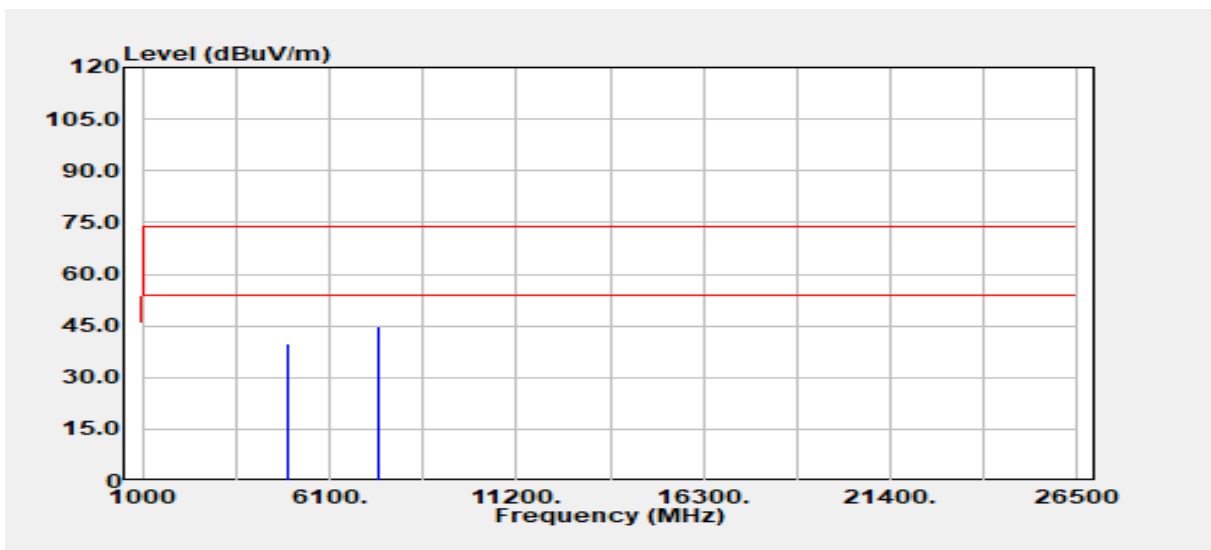

Freq. MHz	Detector Mode PK/QP/AV	Spectrum Read Level dBuV	Factor dB	Actual FS dBuV/m	Limit dBuV/m	Margin dB
4960.00	Peak	36.62	3.21	39.83	74.00	-34.17
4960.00	Average	27.57	3.21	30.78	54.00	-23.22
7440.00	Peak	35.86	8.92	44.78	74.00	-29.22
7440.00	Average	26.28	8.92	35.20	54.00	-18.80

Report No.: TMWK2403000680KR

Rev.: 01

Project No	:TM-2403000180P	Test Date	:2024-04-08
Operation Band	:BT BR	Temp./Humi.	:24.4/60
Frequency	:2480 MHz	Antenna Pol.	:Horizontal
Operation Mode	:TX	Engineer	:Ray.Li
EUT Pol	:E2	Test Chamber	: 966A
Setting	:		

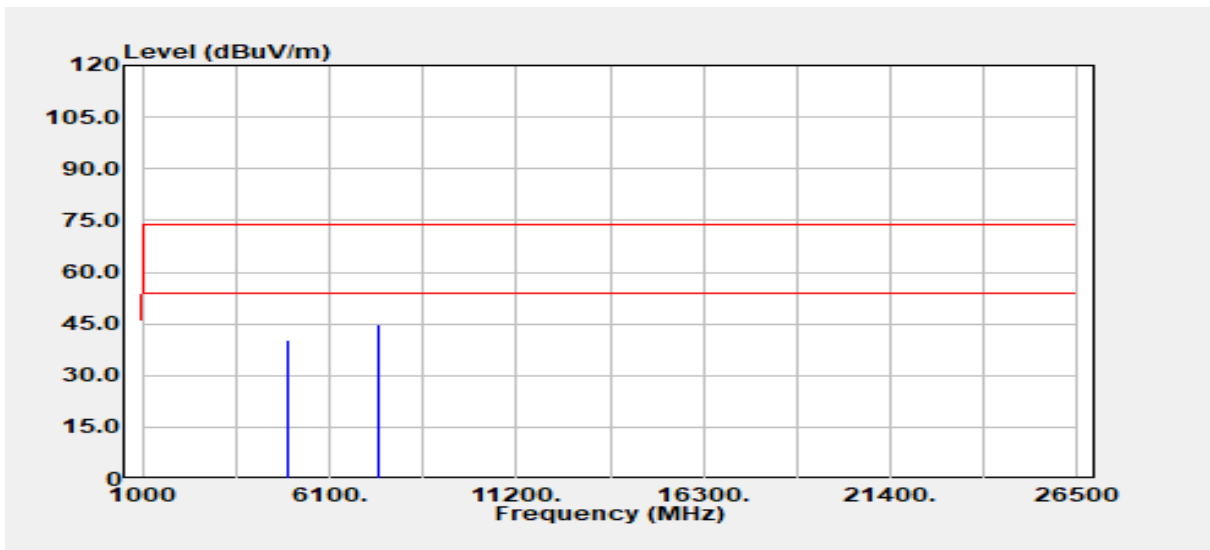

Freq. MHz	Detector Mode PK/QP/AV	Spectrum Read Level dB μ V	Factor dB	Actual FS dB μ V/m	Limit dB μ V/m	Margin dB
4960.00	Peak	37.19	3.21	40.41	74.00	-33.59
4960.00	Average	28.10	3.21	31.32	54.00	-22.68
7440.00	Peak	35.85	8.92	44.77	74.00	-29.23
7440.00	Average	26.77	8.92	35.69	54.00	-18.31

Report No.: TMWK2403000680KR

Rev.: 01

Project No	:TM-2403000180P	Test Date	:2024-04-08
Operation Band	:BT EDR	Temp./Humi.	:24.4/60
Frequency	:2480 MHz	Antenna Pol.	:Vertical
Operation Mode	:TX	Engineer	:Ray.Li
EUT Pol	:E2	Test Chamber	: 966A
Setting	:		

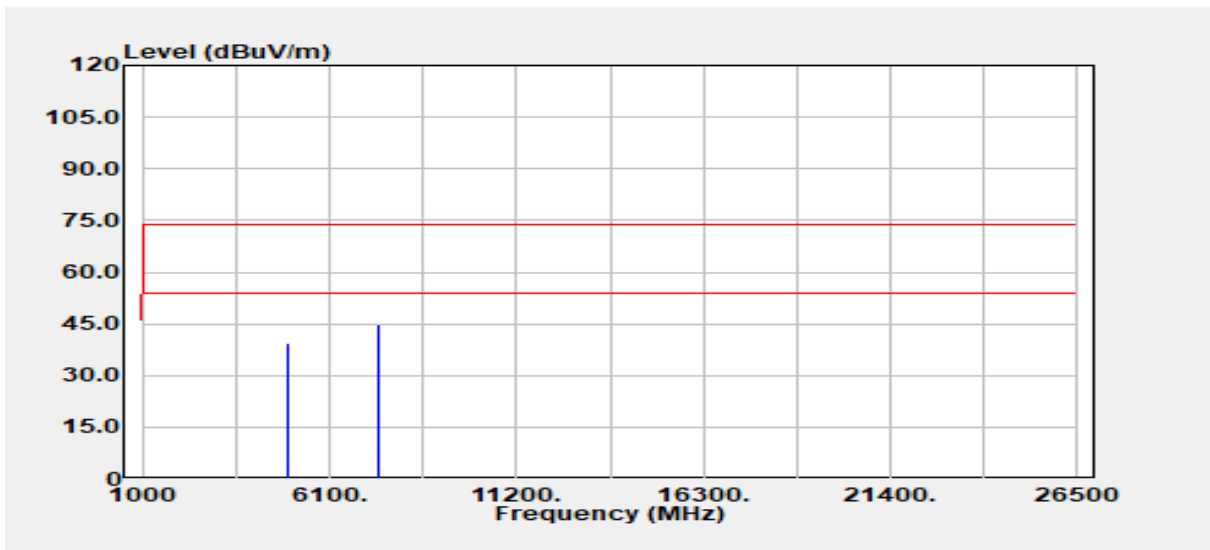

Freq. MHz	Detector Mode PK/QP/AV	Spectrum Read Level dB μ V	Factor dB	Actual FS dB μ V/m	Limit dB μ V/m	Margin dB
4960.00	Peak	36.26	3.21	39.47	74.00	-34.53
4960.00	Average	27.67	3.21	30.88	54.00	-23.12
7440.00	Peak	35.68	8.92	44.60	74.00	-29.40
7440.00	Average	26.44	8.92	35.36	54.00	-18.64

Report No.: TMWK2403000680KR

Rev.: 01

Project No	:TM-2403000180P	Test Date	:2024-04-08
Operation Band	:BT EDR	Temp./Humi.	:24.4/60
Frequency	:2480 MHz	Antenna Pol.	:Horizontal
Operation Mode	:TX	Engineer	:Ray.Li
EUT Pol	:E2	Test Chamber	: 966A
Setting	:		

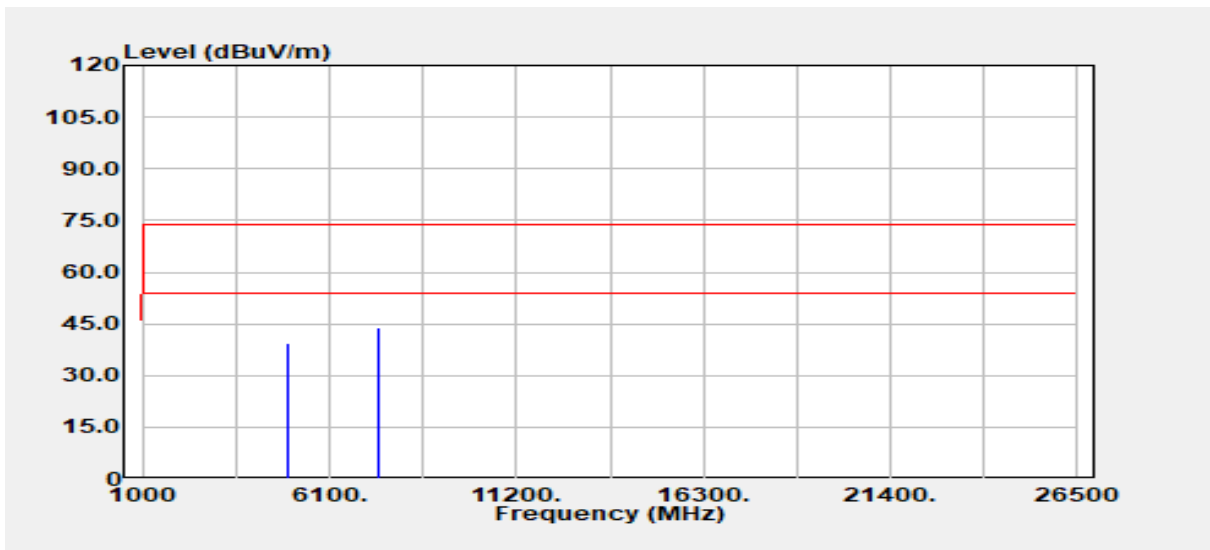

Freq. MHz	Detector Mode PK/QP/AV	Spectrum Read Level dB μ V	Factor dB	Actual FS dB μ V/m	Limit dB μ V/m	Margin dB
4960.00	Peak	36.02	3.21	39.23	74.00	-34.77
4960.00	Average	27.61	3.21	30.82	54.00	-23.18
7440.00	Peak	35.20	8.92	44.12	74.00	-29.88
7440.00	Average	26.67	8.92	35.59	54.00	-18.41

Band Edge Test Data (WIFI 5GHz)

Project No	:TM-2403000180P	Test Date	:2024-04-25
Operation Band	:802.11ac80/Band1	Temp./Humi.	:24.4/60
Frequency	:5210 MHz	Antenna Pol.	:VERTICAL
Operation Mode	:Bandedge	Engineer	:Tony.Chao
EUT Pol	:E2	Test Chamber	: 966A
Setting	:		

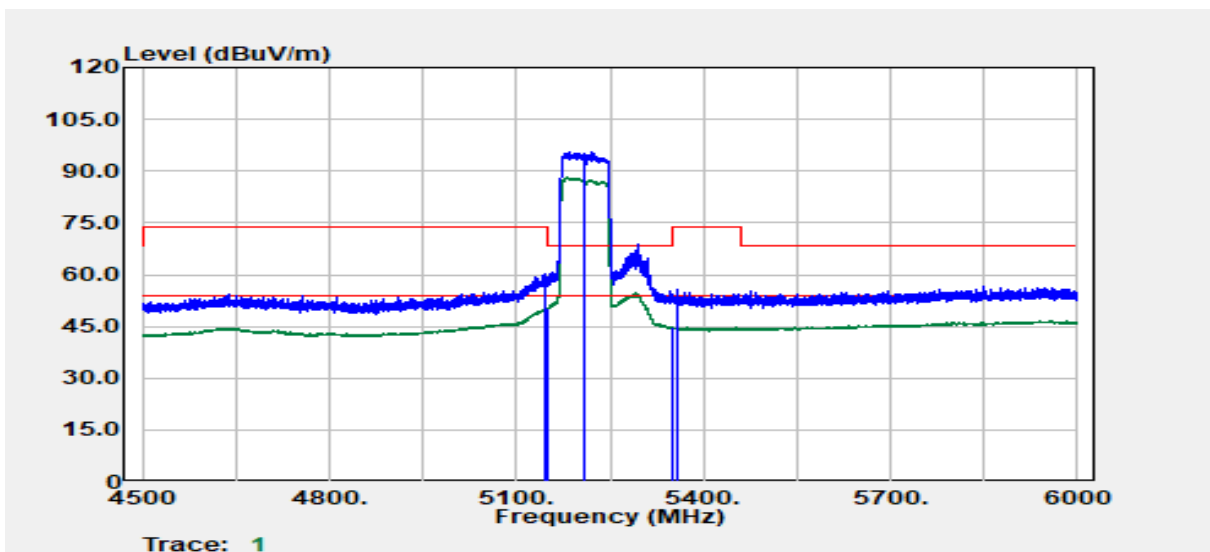

Freq. MHz	Detector Mode PK/QP/AV	Spectrum Read Level dBuV	Factor dB	Actual FS dBuV/m	Limit dBuV/m	Margin dB
5147.43	Peak	47.12	12.92	60.04	74.00	-13.96
5148.43	Average	37.45	12.92	50.37	54.00	-3.63
5210.00	Peak	82.58	13.06	95.63	--	--
5210.00	Average	75.06	13.06	88.12	--	--
5351.82	Average	31.66	13.10	44.75	54.00	-9.25
5357.07	Peak	42.51	13.11	55.61	74.00	-18.39

Report No.: TMWK2403000680KR

Rev.: 01

Project No :TM-2403000180P
 Operation Band :802.11ac80/Band1
 Frequency :5210 MHz
 Operation Mode :Bandedge
 EUT Pol :E2
 Setting :

Test Date :2024-04-25
 Temp./Humi. :24.4/60
 Antenna Pol. :HORIZONTAL
 Engineer :Tony.Chao
 Test Chamber : 966A

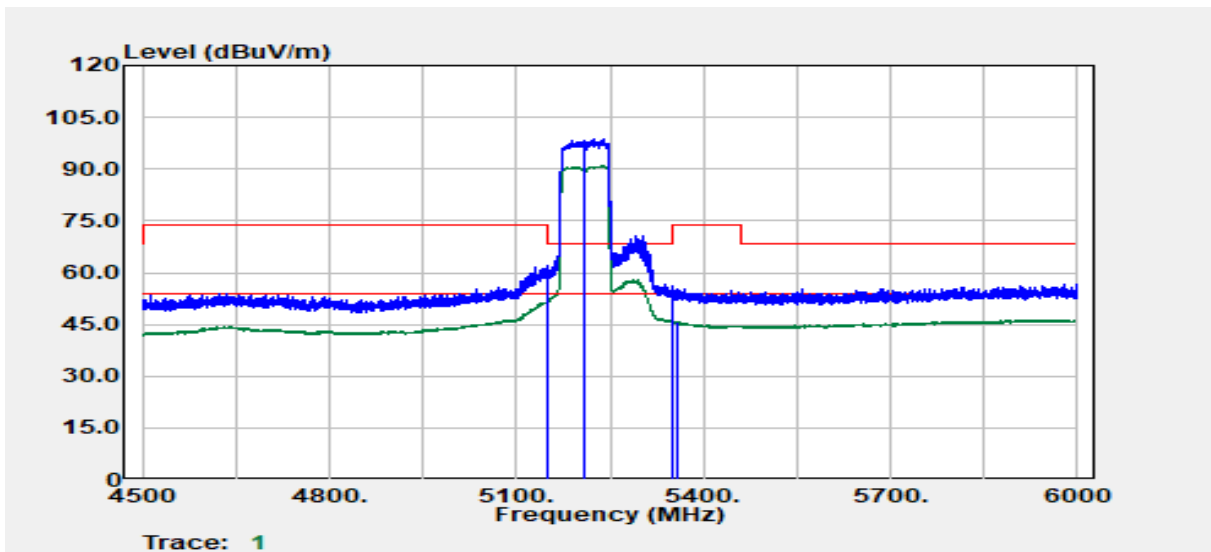

Freq. MHz	Detector Mode PK/QP/AV	Spectrum Read Level dB μ V	Factor dB	Actual FS dB μ V/m	Limit dB μ V/m	Margin dB
5148.93	Average	39.51	12.92	52.43	54.00	-1.57
5149.68	Peak	48.97	12.92	61.89	74.00	-12.11
5210.00	Peak	85.79	13.06	98.84	--	--
5210.00	Average	77.91	13.06	90.97	--	--
5351.82	Peak	43.02	13.10	56.12	74.00	-17.88
5356.82	Average	32.82	13.11	45.92	54.00	-8.08

Report No.: TMWK2403000680KR

Rev.: 01

Project No	:TM-2403000180P	Test Date	:2024-04-25
Operation Band	:802.11ac80/Band2	Temp./Humi.	:24.4/60
Frequency	:5290 MHz	Antenna Pol.	:VERTICAL
Operation Mode	:Bandedge	Engineer	:Tony.Chao
EUT Pol	:E2	Test Chamber	: 966A
Setting	:		

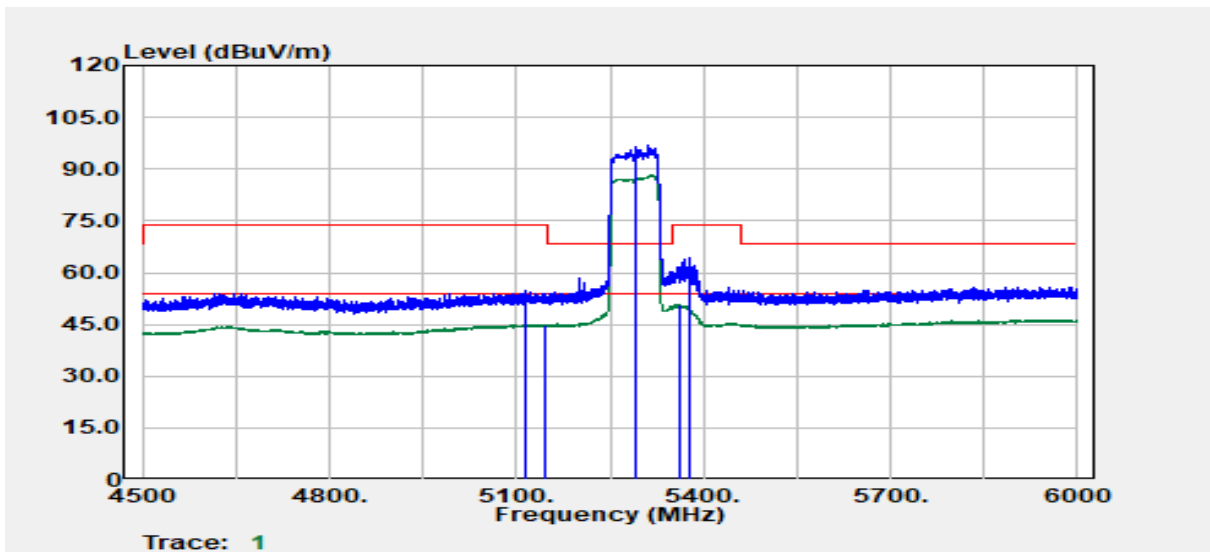

Freq. MHz	Detector Mode PK/QP/AV	Spectrum Read Level dBμV	Factor dB	Actual FS dBμV/m	Limit dBμV/m	Margin dB
5112.69	Peak	41.73	12.95	54.68	74.00	-19.32
5145.43	Average	31.97	12.92	44.90	54.00	-9.10
5290.00	Peak	83.46	13.30	96.76	--	--
5290.00	Average	74.97	13.30	88.28	--	--
5362.57	Average	37.63	13.12	50.75	54.00	-3.25
5377.56	Peak	50.97	13.14	64.11	74.00	-9.89

Report No.: TMWK2403000680KR

Rev.: 01

Project No	:TM-2403000180P	Test Date	:2024-04-25
Operation Band	:802.11ac80/Band2	Temp./Humi.	:24.4/60
Frequency	:5290 MHz	Antenna Pol.	:HORIZONTAL
Operation Mode	:Bandedge	Engineer	:Tony.Chao
EUT Pol	:E2	Test Chamber	: 966A
Setting	:		

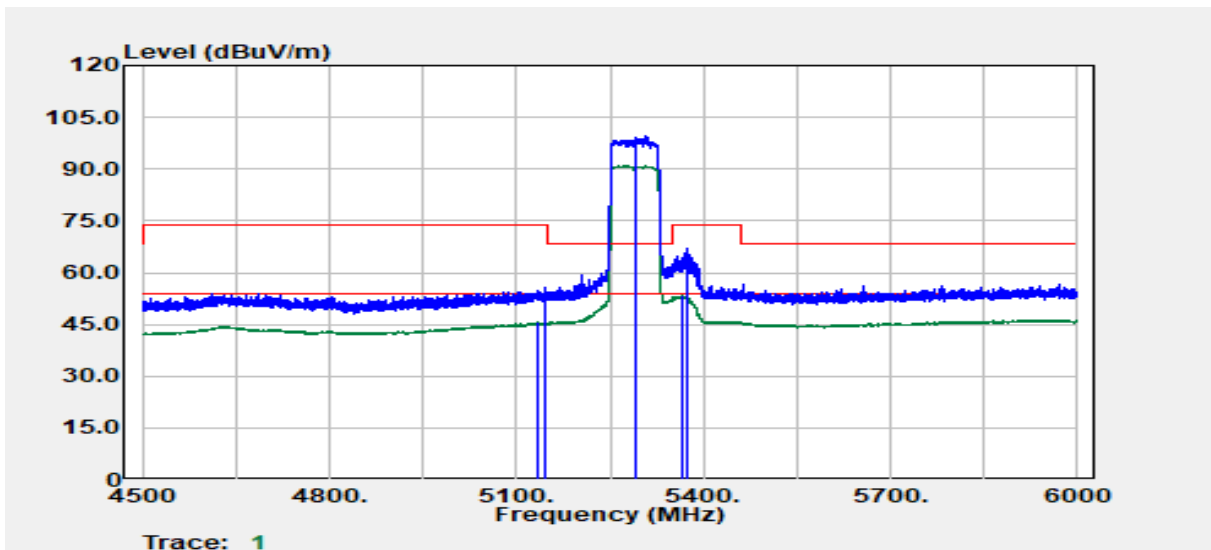

Freq. MHz	Detector Mode PK/QP/AV	Spectrum Read Level dB μ V	Factor dB	Actual FS dB μ V/m	Limit dB μ V/m	Margin dB
5134.43	Average	32.58	12.93	45.51	54.00	-8.49
5146.68	Peak	42.98	12.92	55.90	74.00	-18.10
5290.00	Peak	86.14	13.30	99.44	--	--
5290.00	Average	77.72	13.30	91.02	--	--
5367.82	Average	40.13	13.13	53.26	54.00	-0.74
5371.81	Peak	53.91	13.13	67.04	74.00	-6.96

Report No.: TMWK2403000680KR

Rev.: 01

Project No	:TM-2403000180P	Test Date	:2024-04-25
Operation Band	:802.11n40/Band3	Temp./Humi.	:24.4/60
Frequency	:5510 MHz	Antenna Pol.	:VERTICAL
Operation Mode	:Bandedge	Engineer	:Tony.Chao
EUT Pol	:E2	Test Chamber	: 966A
Setting	:		

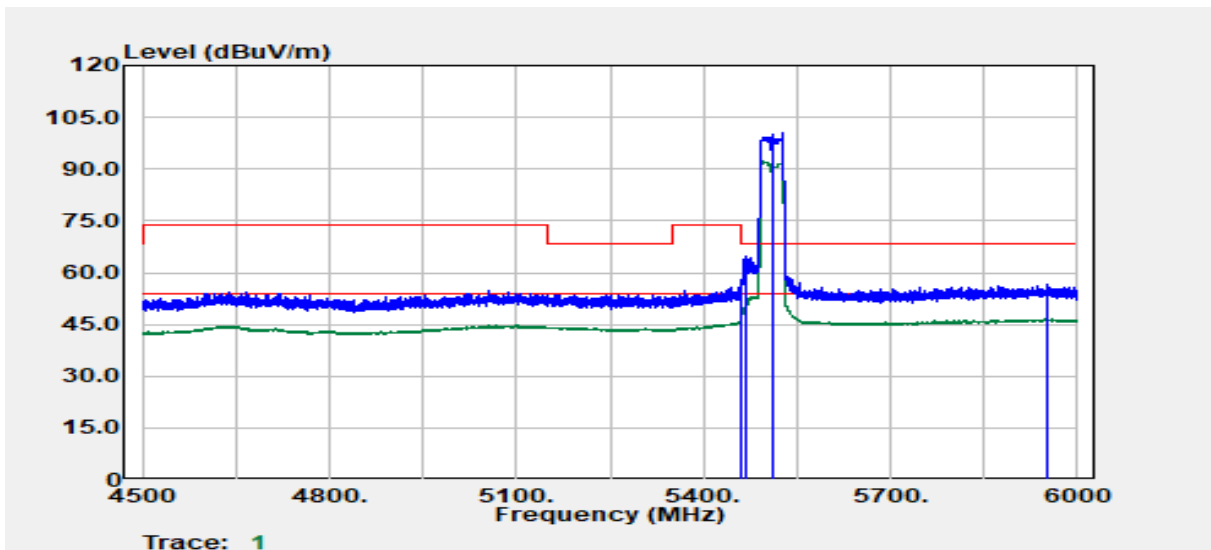

Freq. MHz	Detector Mode PK/QP/AV	Spectrum Read Level dBμV	Factor dB	Actual FS dBμV/m	Limit dBμV/m	Margin dB
5460.00	Peak	43.30	13.50	56.80	68.20	-11.40
5460.00	Average	33.46	13.50	46.95	54.00	-7.05
5466.77	Peak	51.15	13.48	64.63	68.20	-3.57
5510.00	Peak	87.01	13.43	100.44	--	--
5510.00	Average	78.75	13.43	92.17	--	--
5951.02	Peak	41.04	15.36	56.41	68.20	-11.79

Report No.: TMWK2403000680KR

Rev.: 01

Project No :TM-2403000180P
 Operation Band :802.11n40/Band3
 Frequency :5510 MHz
 Operation Mode :Bandedge
 EUT Pol :E2
 Setting :

Test Date :2024-04-25
 Temp./Humi. :24.4/60
 Antenna Pol. :HORIZONTAL
 Engineer :Tony.Chao
 Test Chamber : 966A

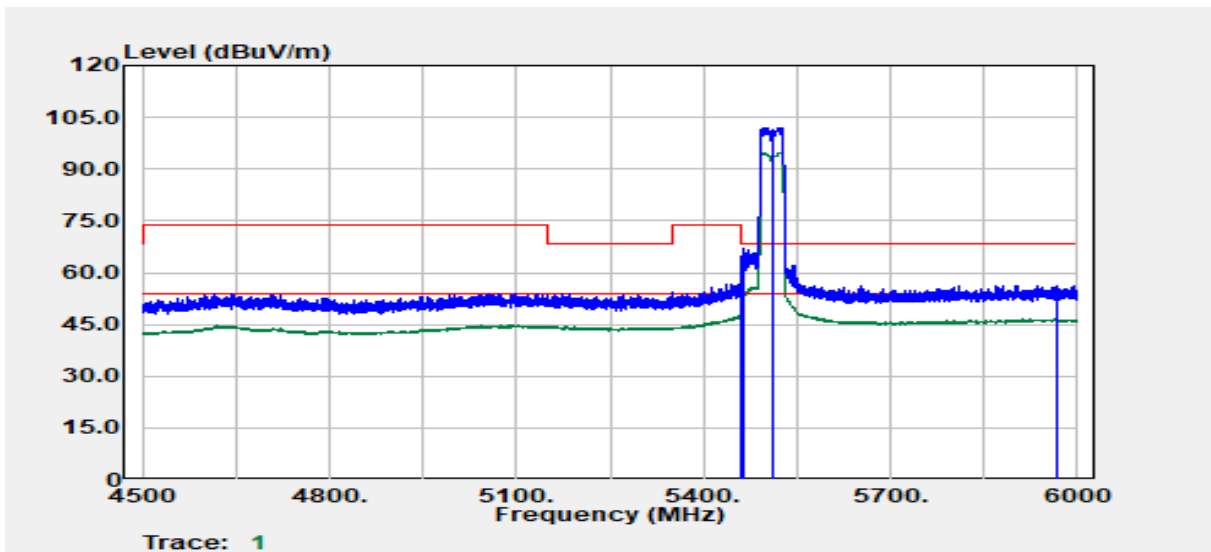

Freq. MHz	Detector Mode PK/QP/AV	Spectrum Read Level dBμV	Factor dB	Actual FS dBμV/m	Limit dBμV/m	Margin dB
5459.77	Peak	47.61	13.50	61.11	74.00	-12.89
5459.77	Average	35.97	13.50	49.47	54.00	-4.53
5465.02	Peak	53.74	13.48	67.22	68.20	-0.98
5510.00	Peak	88.62	13.43	102.05	--	--
5510.00	Average	81.39	13.43	94.82	--	--
5969.02	Peak	40.97	15.33	56.30	68.20	-11.90

Report No.: TMWK2403000680KR

Rev.: 01

Project No	:TM-2403000180P	Test Date	:2024-04-25
Operation Band	:802.11n40/Band4	Temp./Humi.	:24.3/61
Frequency	:5755 MHz	Antenna Pol.	:VERTICAL
Operation Mode	:Bandedge	Engineer	:Ray.Li
EUT Pol	:E2	Test Chamber	: 966A
Setting	:		

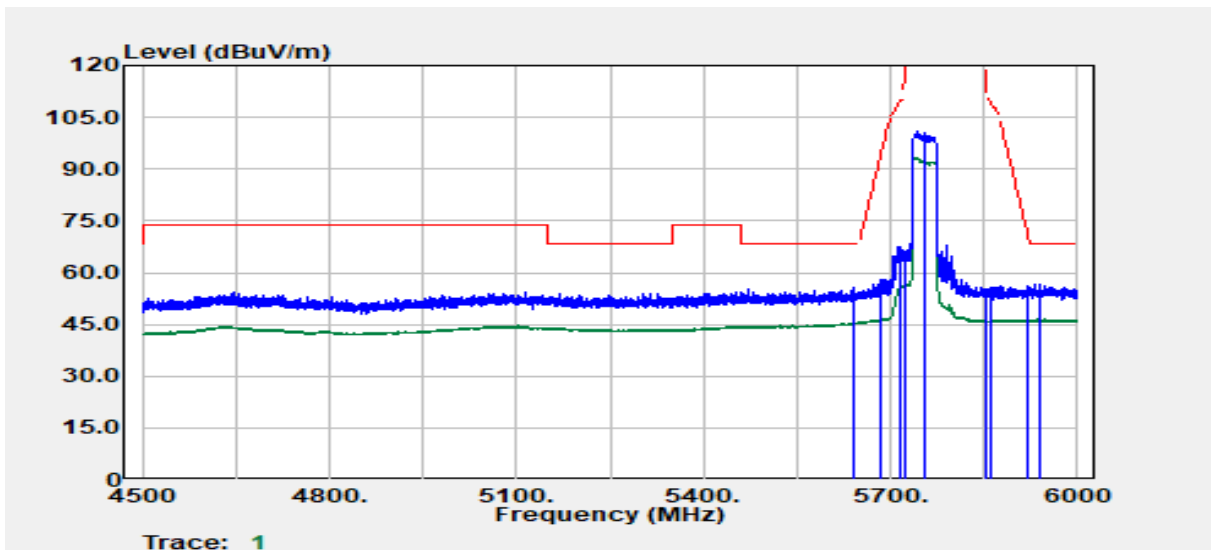

Freq. MHz	Detector Mode PK/QP/AV	Spectrum Read Level dB μ V	Factor dB	Actual FS dB μ V/m	Limit dB μ V/m	Margin dB
5641.19	Peak	41.35	14.18	55.53	68.20	-12.67
5683.95	Peak	43.51	14.61	58.12	93.36	-35.23
5716.20	Peak	52.77	14.89	67.67	109.74	-42.07
5723.20	Peak	51.33	14.94	66.28	118.11	-51.83
5755.00	Peak	85.81	15.15	100.96	--	--
5755.00	Average	78.08	15.15	93.23	--	--
5853.23	Peak	40.02	15.12	55.14	114.84	-59.70
5860.23	Peak	40.73	15.12	55.85	109.33	-53.48
5921.49	Peak	40.88	15.23	56.10	70.79	-14.69
5938.24	Peak	41.30	15.31	56.61	68.20	-11.59

Report No.: TMWK2403000680KR

Rev.: 01

Project No :TM-2403000180P
 Operation Band :802.11n40/Band4
 Frequency :5755 MHz
 Operation Mode :Bandedge
 EUT Pol :E2
 Setting :

Test Date :2024-04-25
 Temp./Humi. :24.3/61
 Antenna Pol. :HORIZONTAL
 Engineer :Ray.Li
 Test Chamber : 966A

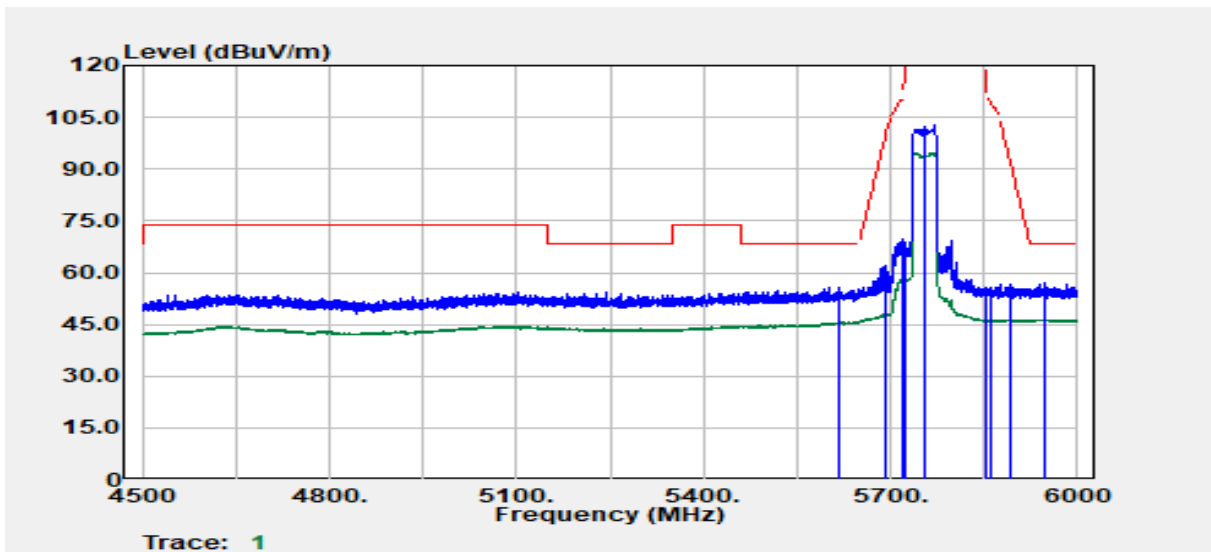

Freq. MHz	Detector Mode PK/QP/AV	Spectrum Read Level dB μ V	Factor dB	Actual FS dB μ V/m	Limit dB μ V/m	Margin dB
5616.44	Peak	41.84	13.94	55.78	68.20	-12.42
5691.70	Peak	47.36	14.69	62.06	99.08	-37.02
5718.20	Peak	54.97	14.91	69.87	110.30	-40.42
5723.95	Peak	53.74	14.95	68.69	119.82	-51.13
5755.00	Peak	87.74	15.15	102.89	--	--
5755.00	Average	79.55	15.15	94.70	--	--
5852.98	Peak	40.41	15.12	55.54	115.41	-59.88
5860.48	Peak	40.56	15.12	55.68	109.26	-53.58
5891.73	Peak	41.45	15.12	56.57	92.78	-36.21
5948.74	Peak	41.72	15.36	57.08	68.20	-11.12

TX Test Data (WIFI 5GHz)

Project No	:TM-2403000180P	Test Date	:2024-04-26
Operation Band	:802.11ac80/Band1	Temp./Humi.	:24.4/60
Frequency	:5210 MHz	Antenna Pol.	:VERTICAL
Operation Mode	:TX	Engineer	:Tony.Chao
EUT Pol	:E2	Test Chamber	: 966A
Setting	:		

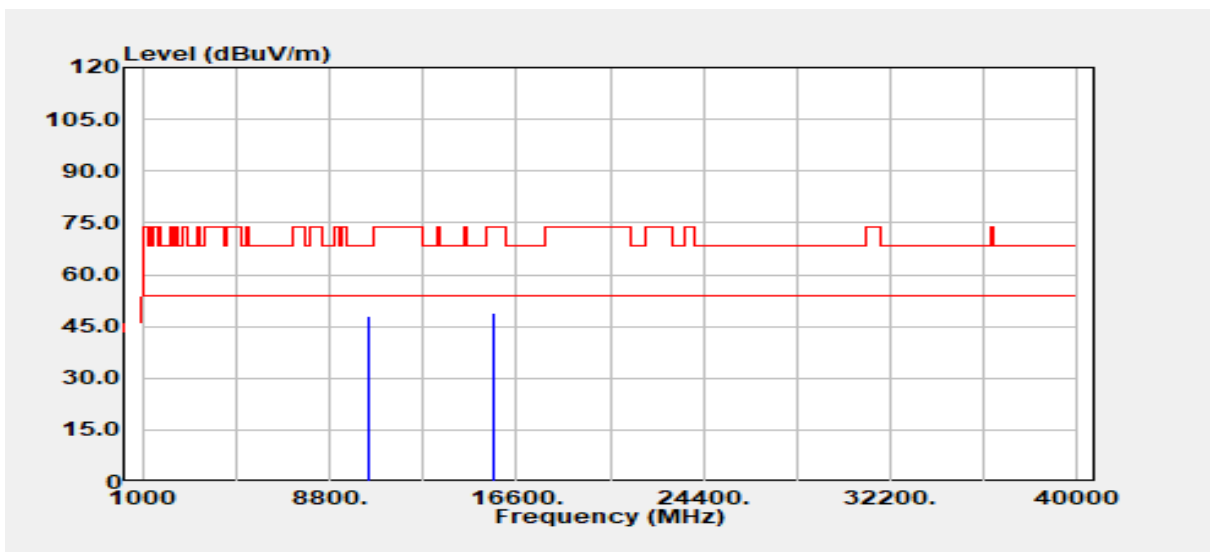

Freq. MHz	Detector Mode PK/QP/AV	Spectrum Read Level dBuV	Factor dB	Actual FS dBuV/m	Limit dBuV/m	Margin dB
10420.00	Peak	35.27	12.91	48.19	68.20	-20.01
15630.00	Peak	33.66	15.41	49.07	74.00	-24.93
15630.00	Average	24.14	15.41	39.55	54.00	-14.45

Report No.: TMWK2403000680KR

Rev.: 01

Project No :TM-2403000180P
 Operation Band :802.11ac80/Band1
 Frequency :5210 MHz
 Operation Mode :TX
 EUT Pol :E2
 Setting :

Test Date :2024-04-26
 Temp./Humi. :24.4/60
 Antenna Pol. :HORIZONTAL
 Engineer :Tony.Chao
 Test Chamber : 966A

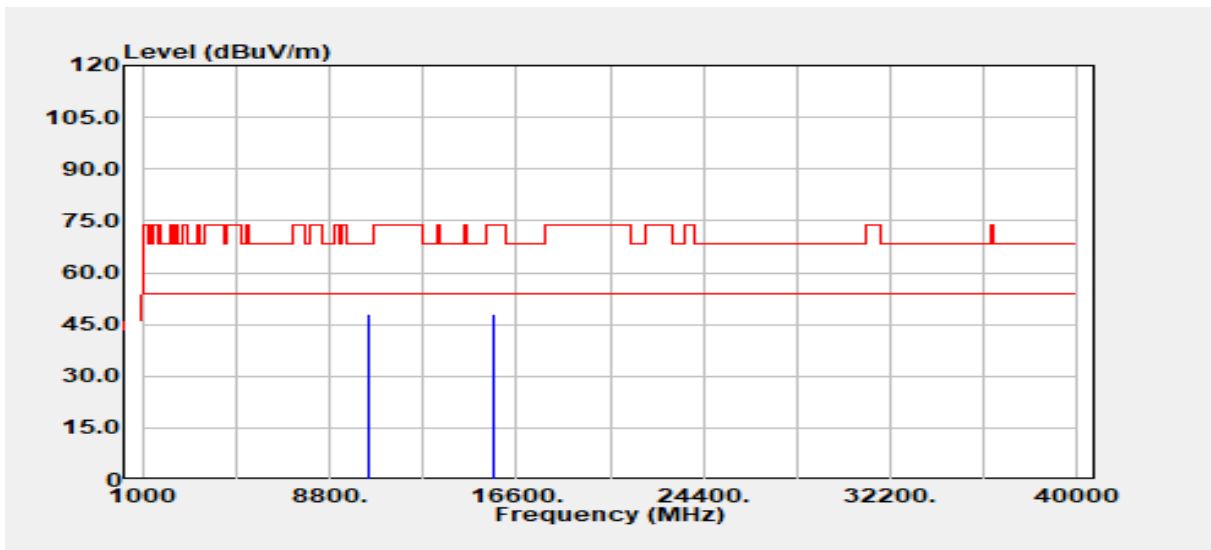

Freq. MHz	Detector Mode PK/QP/AV	Spectrum Read Level dB μ V	Factor dB	Actual FS dB μ V/m	Limit dB μ V/m	Margin dB
10420.00	Peak	35.27	12.91	48.18	68.20	-20.02
15630.00	Peak	32.74	15.41	48.15	74.00	-25.85
15630.00	Average	24.35	15.41	39.76	54.00	-14.24

Report No.: TMWK2403000680KR

Rev.: 01

Project No	:TM-2403000180P	Test Date	:2024-04-26
Operation Band	:802.11ac80/Band2	Temp./Humi.	:24.4/60
Frequency	:5290 MHz	Antenna Pol.	:VERTICAL
Operation Mode	:TX	Engineer	:Tony.Chao
EUT Pol	:E2	Test Chamber	: 966A
Setting	:		

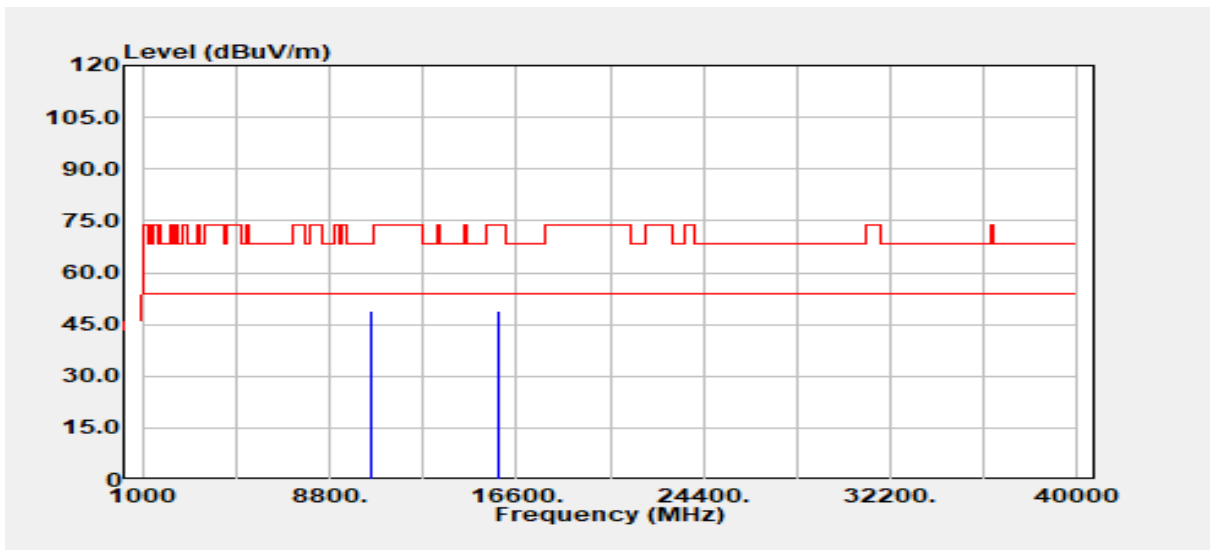

Freq. MHz	Detector Mode PK/QP/AV	Spectrum Read Level dB μ V	Factor dB	Actual FS dB μ V/m	Limit dB μ V/m	Margin dB
10580.00	Peak	35.78	12.96	48.74	68.20	-19.46
15870.00	Peak	32.91	16.00	48.91	74.00	-25.09
15870.00	Average	24.79	16.00	40.80	54.00	-13.20

Report No.: TMWK2403000680KR

Rev.: 01

Project No :TM-2403000180P
 Operation Band :802.11ac80/Band2
 Frequency :5290 MHz
 Operation Mode :TX
 EUT Pol :E2
 Setting :

Test Date :2024-04-26
 Temp./Humi. :24.4/60
 Antenna Pol. :HORIZONTAL
 Engineer :Tony.Chao
 Test Chamber : 966A

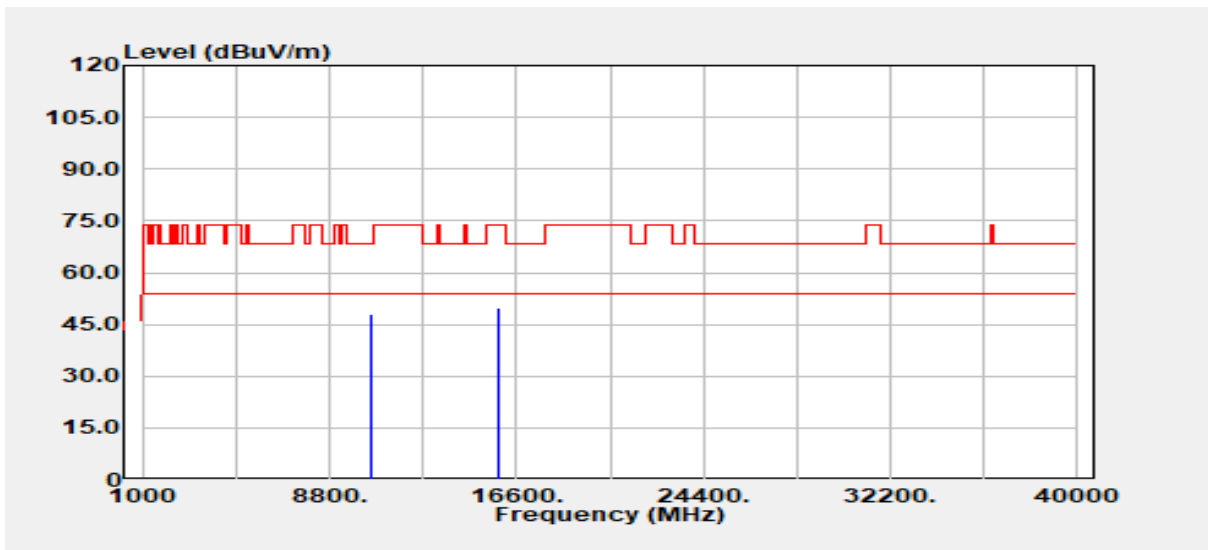

Freq. MHz	Detector Mode PK/QP/AV	Spectrum Read Level dB μ V	Factor dB	Actual FS dB μ V/m	Limit dB μ V/m	Margin dB
10580.00	Peak	34.90	12.96	47.86	68.20	-20.34
15870.00	Peak	33.89	16.00	49.89	74.00	-24.11
15870.00	Average	24.97	16.00	40.98	54.00	-13.02

Report No.: TMWK2403000680KR

Rev.: 01

Project No :TM-2403000180P
 Operation Band :802.11n40/Band3
 Frequency :5510 MHz
 Operation Mode :TX
 EUT Pol :E2
 Setting :

Test Date :2024-04-26
 Temp./Humi. :24.4/60
 Antenna Pol. :VERTICAL
 Engineer :Tony.Chao
 Test Chamber : 966A

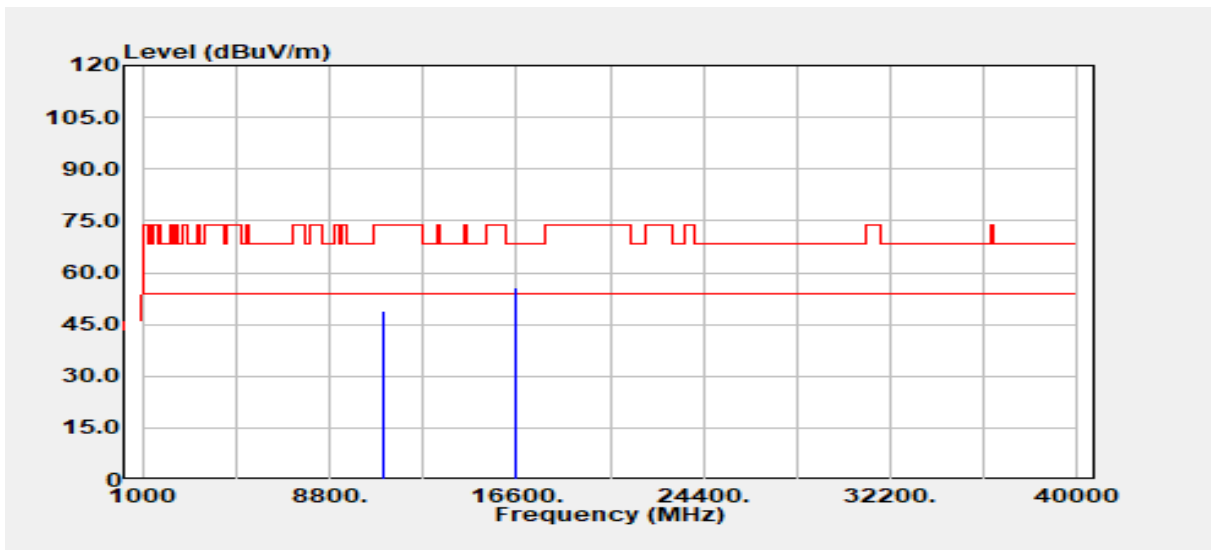

Freq. MHz	Detector Mode PK/QP/AV	Spectrum Read Level dB μ V	Factor dB	Actual FS dB μ V/m	Limit dB μ V/m	Margin dB
11020.00	Peak	35.08	13.75	48.83	74.00	-25.17
11020.00	Average	23.49	13.75	37.23	54.00	-16.77
16530.00	Peak	34.74	20.98	55.71	68.20	-12.49

Report No.: TMWK2403000680KR

Rev.: 01

Project No :TM-2403000180P
 Operation Band :802.11n40/Band3
 Frequency :5510 MHz
 Operation Mode :TX
 EUT Pol :E2
 Setting :

Test Date :2024-04-26
 Temp./Humi. :24.4/60
 Antenna Pol. :HORIZONTAL
 Engineer :Tony.Chao
 Test Chamber : 966A

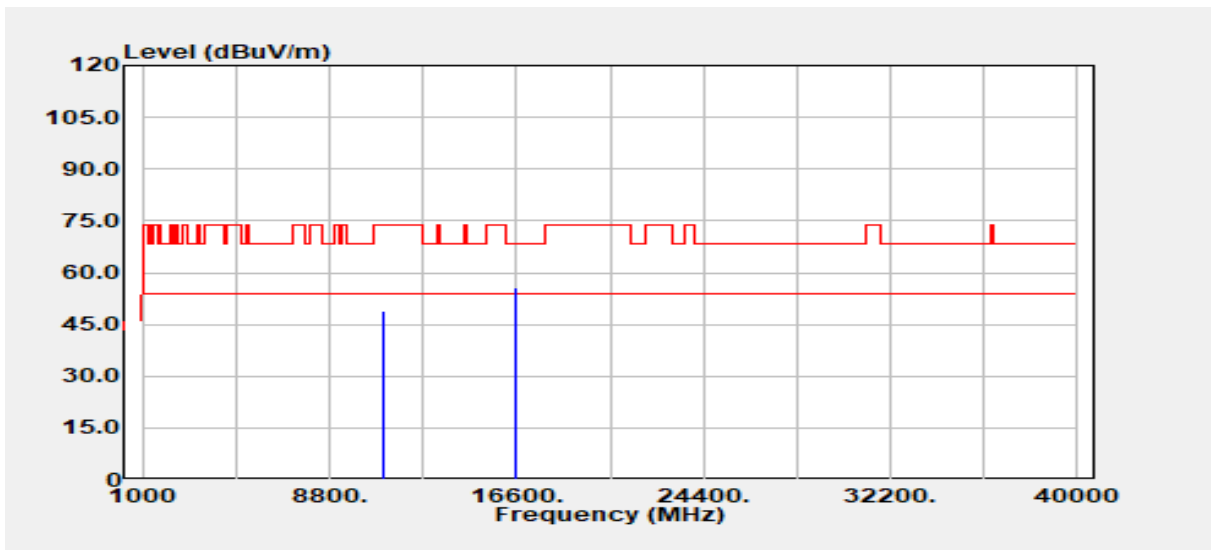

Freq. MHz	Detector Mode PK/QP/AV	Spectrum Read Level dB μ V	Factor dB	Actual FS dB μ V/m	Limit dB μ V/m	Margin dB
11020.00	Peak	35.23	13.75	48.98	74.00	-25.02
11020.00	Average	24.45	13.75	38.20	54.00	-15.80
16530.00	Peak	34.92	20.98	55.90	68.20	-12.30

Report No.: TMWK2403000680KR

Rev.: 01

Project No	:TM-2403000180P	Test Date	:2024-04-26
Operation Band	:802.11n40/Band4	Temp./Humi.	:24.4/60
Frequency	:5755 MHz	Antenna Pol.	:VERTICAL
Operation Mode	:TX	Engineer	:Tony.Chao
EUT Pol	:E2	Test Chamber	: 966A
Setting	:		

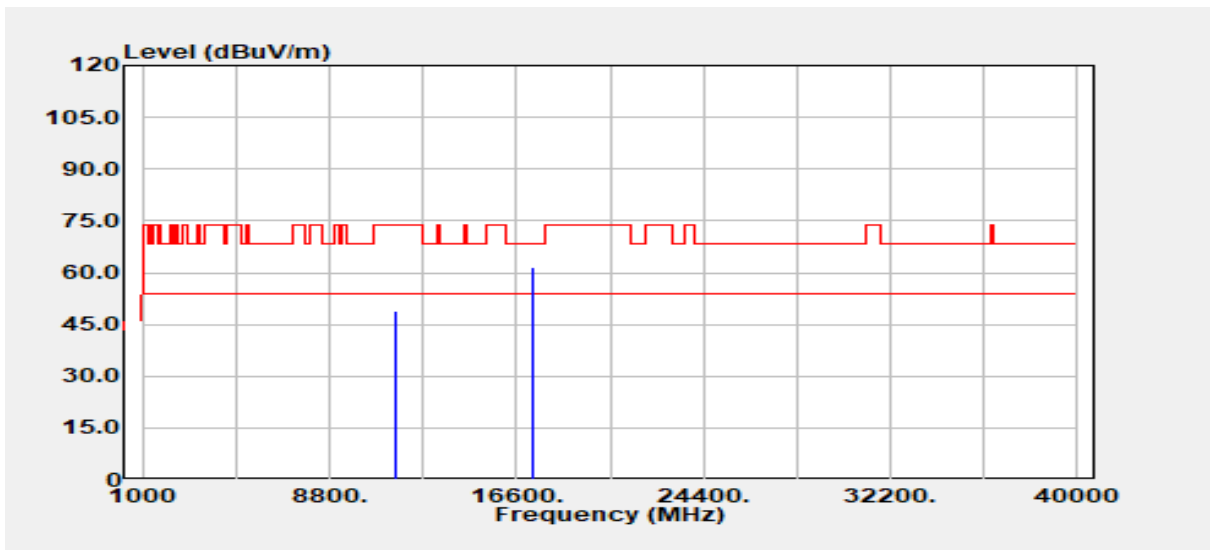

Freq. MHz	Detector Mode PK/QP/AV	Spectrum Read Level dB μ V	Factor dB	Actual FS dB μ V/m	Limit dB μ V/m	Margin dB
11510.00	Peak	34.98	13.77	48.75	74.00	-25.25
11510.00	Average	24.15	13.77	37.92	54.00	-16.08
17265.00	Peak	33.82	27.89	61.71	68.20	-6.49

Report No.: TMWK2403000680KR

Rev.: 01

Project No :TM-2403000180P
 Operation Band :802.11n40/Band4
 Frequency :5755 MHz
 Operation Mode :TX
 EUT Pol :E2
 Setting :

Test Date :2024-04-26
 Temp./Humi. :24.4/60
 Antenna Pol. :HORIZONTAL
 Engineer :Tony.Chao
 Test Chamber : 966A

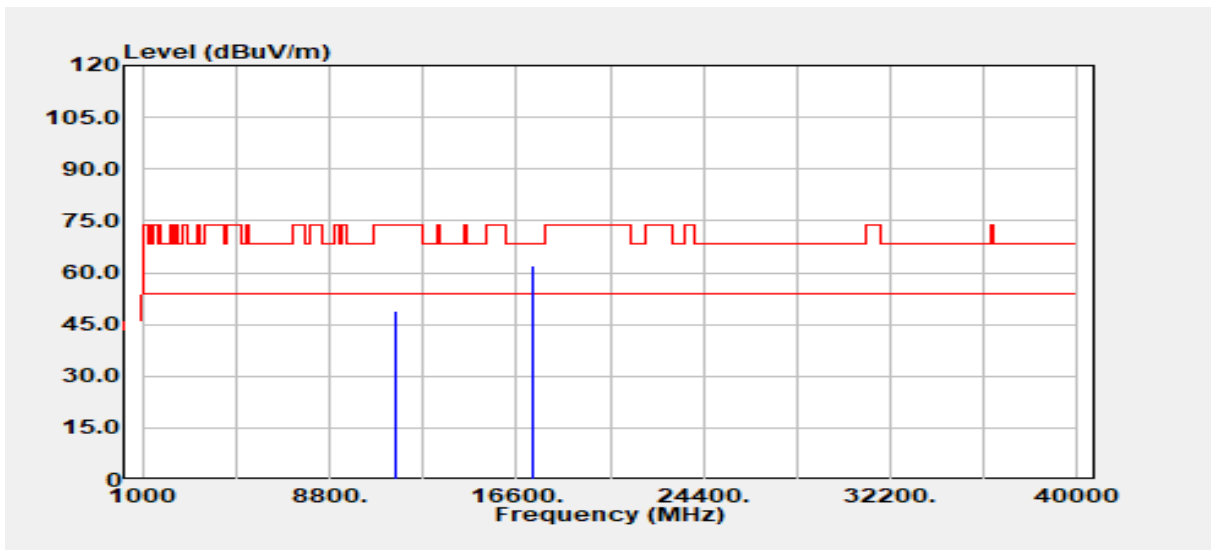

Freq. MHz	Detector Mode PK/QP/AV	Spectrum Read Level dB μ V	Factor dB	Actual FS dB μ V/m	Limit dB μ V/m	Margin dB
11510.00	Peak	35.13	13.77	48.90	74.00	-25.10
11510.00	Average	24.20	13.77	37.97	54.00	-16.03
17265.00	Peak	33.96	27.89	61.85	68.20	-6.35

4.2 TEST DATA RE-USE SUMMARY

Introduction Section:

The application re-uses data collected on a similar device. The subject device of this application (Model: LBEE6XX1UR, FCC ID: VPYLBEE6XX1UR2) is electrically identical to the reference device (Model: LBEE6XX1UR, FCC ID: VPYLBEE6XX1UR) for the portions of the circuitry corresponding to the data being re-used, as treated by KDB Publication 484596 D01.

Differences Brief Description:

The WLAN and Bluetooth hardware of this device are identical to the implementation in

FCC ID: VPYLBEE6XX1UR

The Product Equality Declaration document includes detailed information about the changes between the devices. The data from that application has been verified through appropriate spot checks to demonstrate compliance for this device as shown in the summary table below.

Spot Check Verification Result Summary

Equipment Class	Reference ID	Folder Test	Report Title/Section
DSS-BT	FCC ID: VPYLBEE6XX1UR	TMWK2308002698KR	All Section (Except for Radiation Spurious Emission)
NII-WIFI 5GHz	FCC ID: VPYLBEE6XX1UR	TMWK2308002691KR, TMWK2308002692KR	

Summary of the spot check for Unlicensed bands

In order to confirm hardware similarity of the subject device with the reference device, we used same setting power to radiated emission measurement were performed on the subject device for the Band edge and Harmonic, the test result were similar with FCC ID: VPYLBEE6XX1UR.

DSS-BT: BT BR
Bandedge

Mode	Update FCC ID: VPYLBEE6XX1UR2					Original FCC ID: VPYLBEE6XX1UR					Gap (dB)
	Measured Frequency (MHz)	Power set	Polarity	Level (dBuV/m)	Remark	Measured Frequency (MHz)	Power set	Polarity	Level (dBuV/m)	Remark	
E1	2483.529	Default	V	48.18	Peak	2489.076	Default	V	46.8	Peak	-1.38
E1	2498.51	Default	V	39.4	Avg	2483.573	Default	V	37.82	Avg	-1.58

Harmonic

Mode	Update FCC ID: VPYLBEE6XX1UR2					Original FCC ID: VPYLBEE6XX1UR					Gap (dB)
	Measured Frequency (MHz)	Power set	Polarity	Level (dBuV/m)	Remark	Measured Frequency (MHz)	Power set	Polarity	Level (dBuV/m)	Remark	
E1	4960	Default	V	39.83	Peak	4960	Default	V	39.07	Peak	-0.76
E1	4960	Default	V	30.78	Avg	4960	Default	V	30.36	Avg	-0.42

DSS-BT: BT EDR
Bandedge

Mode	Update FCC ID: VPYLBEE6XX1UR2					Original FCC ID: VPYLBEE6XX1UR					Gap (dB)
	Measured Frequency (MHz)	Power set	Polarity	Level (dBuV/m)	Remark	Measured Frequency (MHz)	Power set	Polarity	Level (dBuV/m)	Remark	
E1	2486.775	Default	V	48.4	Peak	2490.068	Default	V	46.39	Peak	-2.01
E1	2484.528	Default	V	40.65	Avg	2483.5	Default	V	39.18	Avg	-1.47

Harmonic

Mode	Update FCC ID: VPYLBEE6XX1UR2					Original FCC ID: VPYLBEE6XX1UR					Gap (dB)
	Measured Frequency (MHz)	Power set	Polarity	Level (dBuV/m)	Remark	Measured Frequency (MHz)	Power set	Polarity	Level (dBuV/m)	Remark	
E1	4960	Default	V	39.47	Peak	4960	Default	V	39.93	Peak	0.46
E1	4960	Default	V	30.88	Avg	4960	Default	V	29.8	Avg	-1.08

NII: WIFI 5GHz Band I: ac80_5210 MHz
Bandedge

Mode	Update FCC ID: VPYLBEE6XX1UR2					Original FCC ID: VPYLBEE6XX1UR					Gap (dB)
	Measured Frequency (MHz)	Power set	Polarity	Level (dBuV/m)	Remark	Measured Frequency (MHz)	Power set	Polarity	Level (dBuV/m)	Remark	
E2	5149.68	58	H	61.89	Peak	5147.4	58	H	63.34	Peak	1.45
E2	5148.93	58	H	52.43	Avg	5147.7	58	H	53.42	Avg	0.99

Harmonic

Mode	Update FCC ID: VPYLBEE6XX1UR2					Original FCC ID: VPYLBEE6XX1UR					Gap (dB)
	Measured Frequency (MHz)	Power set	Polarity	Level (dBuV/m)	Remark	Measured Frequency (MHz)	Power set	Polarity	Level (dBuV/m)	Remark	
E2	15630	58	H	48.15	Peak	15630	58	H	46.55	Peak	-1.6
E2	15630	58	H	39.76	Avg	15630	58	H	37.6	Avg	-2.16

NII: WIFI 5GHz Band II: ac80_5290 MHz
Bandedge

Mode	Update FCC ID: VPYLBEE6XX1UR2					Original FCC ID: VPYLBEE6XX1UR					Gap (dB)
	Measured Frequency (MHz)	Power set	Polarity	Level (dBuV/m)	Remark	Measured Frequency (MHz)	Power set	Polarity	Level (dBuV/m)	Remark	
E2	5371.81	55	H	67.04	Peak	5380.2	55	H	66.43	Peak	-0.61
E2	5367.82	55	H	53.26	Avg	5367.9	55	H	53.81	Avg	0.55

Harmonic

Mode	Update FCC ID: VPYLBEE6XX1UR2					Original FCC ID: VPYLBEE6XX1UR					Gap (dB)
	Measured Frequency (MHz)	Power set	Polarity	Level (dBuV/m)	Remark	Measured Frequency (MHz)	Power set	Polarity	Level (dBuV/m)	Remark	
E2	15870	55	H	49.89	Peak	15870	55	H	47.82	Peak	-2.07
E2	15870	55	H	40.98	Avg	15870	55	H	38.98	Avg	-2

NII: WIFI 5GHz Band III: n40_5510 MHz
Bandedge

Mode	Update FCC ID: VPYLBEE6XX1UR2					Original FCC ID: VPYLBEE6XX1UR					Gap (dB)
	Measured Frequency (MHz)	Power set	Polarity	Level (dBuV/m)	Remark	Measured Frequency (MHz)	Power set	Polarity	Level (dBuV/m)	Remark	
E2	5465.02	48	H	67.22	Peak	5465.1	53	V	67.43	Peak	0.21

Harmonic

Mode	Update FCC ID: VPYLBEE6XX1UR2					Original FCC ID: VPYLBEE6XX1UR					Gap (dB)
	Measured Frequency (MHz)	Power set	Polarity	Level (dBuV/m)	Remark	Measured Frequency (MHz)	Power set	Polarity	Level (dBuV/m)	Remark	
E2	11020	48	H	48.98	Peak	11020	53	V	46.46	Peak	-2.52
E2	11020	48	H	38.2	Avg	11020	53	V	37.4	Avg	-0.8

NII: WIFI 5GHz Band IV: n40_5755 MHz
Bandedge

Mode	Update FCC ID: VPYLBEE6XX1UR2					Original FCC ID: VPYLBEE6XX1UR					Gap (dB)
	Measured Frequency (MHz)	Power set	Polarity	Level (dBuV/m)	Remark	Measured Frequency (MHz)	Power set	Polarity	Level (dBuV/m)	Remark	
E2	5948.74	57	H	57.08	Peak	5965.8	50	H	56.16	Peak	-0.92

Harmonic

Mode	Update FCC ID: VPYLBEE6XX1UR2					Original FCC ID: VPYLBEE6XX1UR					Gap (dB)
	Measured Frequency (MHz)	Power set	Polarity	Level (dBuV/m)	Remark	Measured Frequency (MHz)	Power set	Polarity	Level (dBuV/m)	Remark	
E2	11510	57	H	48.9	Peak	11510	50	H	46.65	Peak	-2.25
E2	11510	57	H	37.97	Avg	11510	50	H	37.18	Avg	-0.79

- End of Test Report -