



MEASUREMENT REPORT

FCC PART 15.247 & IC RSS-247 Bluetooth

FCC ID: VPYLBEE5ZZ1PJ
IC: 772C-LBEE5ZZ1PJ
APPLICANT: Murata Manufacturing Co., Ltd.

Application Type: CLASS II PERMISSIVE CHANGE
Product: W-LAN + Bluetooth Module
Model No.: 1PJ
FCC Classification: FCC Part 15 Spread Spectrum Transmitter(DSS)
FCC Rule Part(s): Part 15 Subpart C (Section 15.247)
IC Rule(s): RSS-247 Issue 2, RSS-GEN Issue 5
Test Procedure(s): ANSI C63.10-2013, KDB 558074 D01v05r02
Test Date: May 05 ~ June 24, 2019

Reviewed By:

Kevin Guo

(Kevin Guo)

Approved By:

Robin Wu

(Robin Wu)



The test results relate only to the samples tested.

This equipment has been shown to be capable of compliance with the applicable technical standards as indicated in the measurement report and was tested in accordance with the measurement procedures specified in ANSI C63.10-2013. Test results reported herein relate only to the item(s) tested.

The test report shall not be reproduced except in full without the written approval of MRT Technology (Suzhou) Co., Ltd.

Revision History

Report No.	Version	Description	Issue Date	Note
1904WSU022-U1	Rev. 01	Initial report	06-24-2019	Valid

Note: This report is prepared for FCC Class II permissive change supplement to MRT original "1808WSU011-U1" report adding a PIFA antenna and adding related data.

CONTENTS

Description	Page
1. INTRODUCTION	6
1.1. Scope	6
1.2. MRT Test Location	6
2. PRODUCT INFORMATION	7
2.1. Equipment Description.....	7
2.2. Product Specification Subjective to this Standard	7
2.3. Operation Frequency / Channel List	8
2.4. Pseudorandom Frequency Hopping Sequence.....	9
2.5. Device Capabilities	9
2.6. Test Configuration	9
2.7. Test Software	10
2.8. EMI Suppression Device(s)/Modifications.....	10
2.9. Labeling Requirements.....	10
3. DESCRIPTION of TEST	11
3.1. Evaluation Procedure	11
3.2. AC Line Conducted Emissions	11
3.3. Radiated Emissions	12
4. ANTENNA REQUIREMENTS	13
5. TEST EQUIPMENT CALIBRATION DATE	14
6. MEASUREMENT UNCERTAINTY	16
7. TEST RESULT	17
7.1. Summary	17
7.2. Output Power Measurement.....	18
7.2.1. Test Limit	18
7.2.2. Test Procedure Used	18
7.2.3. Test Setting.....	18
7.2.4. Test Setup.....	18
7.2.5. Test Result.....	19
7.3. Radiated Spurious Emission Measurement	23
7.3.1. Test Limit	23
7.3.2. Test Procedure Used	23
7.3.3. Test Setting.....	23
7.3.4. Test Setup.....	25

7.3.5.	Test Result.....	26
7.4.	Radiated Restricted Band Edge Measurement.....	37
7.4.1.	Test Limit.....	37
7.4.2.	Test Procedure Used.....	40
7.4.3.	Test Setting.....	40
7.4.4.	Test Setup.....	41
7.4.5.	Test Result.....	42
8.	CONCLUSION.....	66
	Appendix A – Test Setup Photograph.....	67
	Appendix B – EUT Photograph.....	68

§2.1033 General Information

Applicant:	Murata Manufacturing Co., Ltd.
Applicant Address:	10-1, Higashikotari 1-chome, Nagaokakyo-shi, Kyoto 617-8555, Japan
Manufacturer:	Murata Manufacturing Co., Ltd.
Manufacturer Address:	10-1, Higashikotari 1-chome, Nagaokakyo-shi, Kyoto 617-8555, Japan
Test Site:	MRT Technology (Suzhou) Co., Ltd
Test Site Address:	D8 Building, Youxin Industrial Park, No.2 Tian'edang Rd., Wuzhong Economic Development Zone, Suzhou, China
Test Device Serial No.:	N/A <input type="checkbox"/> Production <input checked="" type="checkbox"/> Pre-Production <input type="checkbox"/> Engineering

Test Facility / Accreditations

Measurements were performed at MRT Laboratory located in Tian'edang Rd., Suzhou, China.

- MRT facility is a FCC registered (MRT Reg. No. 893164) test facility with the site description report on file and has met all the requirements specified in ANSI C63.4-2014.
- MRT facility is an IC registered (MRT Reg. No. 11384A-1) test laboratory with the site description on file at Industry Canada.
- MRT facility is a VCCI registered (R-20025, G-20034, C-20020, T-20020) test laboratory with the site description on file at VCCI Council.
- MRT Lab is accredited to ISO 17025 by the American Association for Laboratory Accreditation (A2LA) under the American Association for Laboratory Accreditation Program (A2LA Cert. No. 3628.01) in EMC, Telecommunications, Radio and SAR testing.



1. INTRODUCTION

1.1. Scope

Measurement and determination of electromagnetic emissions (EMC) of radio frequency devices including intentional and/or unintentional radiators for compliance with the technical rules and regulations of the Federal Communications Commission and the Industry Canada Certification and Engineering Bureau.

1.2. MRT Test Location

The map below shows the location of the MRT LABORATORY, its proximity to the Taihu Lake. These measurement tests were conducted at the MRT Technology (Suzhou) Co., Ltd. Facility located at D8 Building, No.2 Tian'edang Rd., Wuzhong Economic Development Zone, Suzhou, China. The measurement facility compliant with the test site requirements specified in ANSI C63.4-2014.



2. PRODUCT INFORMATION

2.1. Equipment Description

Product Name:	W-LAN + Bluetooth Module
Model No.:	1PJ
Brand Name:	Murata
Work Voltage	DC 3.3V
Wi-Fi Specification	802.11a/b/g/n/ac
Bluetooth Specification	V5.0 dual mode

2.2. Product Specification Subjective to this Standard

Operating Frequency	2402~2480MHz
Channel Number	79
Type of modulation	GFSK, Pi/4 DQPSK, 8DPSK
Data Rate	1Mbps(GFSK), 2Mbps(Pi/4 DQPSK), 3Mbps (8DPSK)
Antenna type	PIFA Antenna
Antenna Gain	3.29dBi

The equipment under test (EUT) is the **W-LAN + Bluetooth Module**. The test data contained in this report pertains only to the emissions due to the EUT's Bluetooth transmitter.

- 15.247(g): In accordance with the Bluetooth Industry Standard, the system is designed to comply with all of the regulations in Section 15.247 when the transmitter is presented with a continuous data (or information) system.
- 15.247(h): In accordance with the Bluetooth Industry Standard, the system does not coordinate its channels selection/ hopping sequence with other frequency hopping systems for the express purpose of avoiding the simultaneous occupancy of individual hopping frequencies by multiple transmitters.
- 15.247(h): The EUT employs Adaptive Frequency Hopping (AFH) which identifies sources of interference namely devices operating in 802.11 WLAN and excludes them from the list of available channels. The process of re-mapping reduces the number of test channels from 79 channels to a minimum number of 20 channels.

2.3. Operation Frequency / Channel List

Channel	Frequency	Channel	Frequency	Channel	Frequency
00	2402 MHz	01	2403 MHz	02	2404 MHz
03	2405 MHz	04	2406 MHz	05	2407 MHz
06	2408 MHz	07	2409 MHz	08	2410 MHz
09	2411 MHz	10	2412 MHz	11	2413 MHz
12	2414 MHz	13	2415 MHz	14	2416 MHz
15	2417 MHz	16	2418 MHz	17	2419 MHz
18	2420 MHz	19	2421 MHz	20	2422 MHz
21	2423 MHz	22	2424 MHz	23	2425 MHz
24	2426 MHz	25	2427 MHz	26	2428 MHz
27	2429 MHz	28	2430 MHz	29	2431 MHz
30	2432 MHz	31	2433 MHz	32	2434 MHz
33	2435 MHz	34	2436 MHz	35	2437 MHz
36	2438 MHz	37	2439 MHz	38	2440 MHz
39	2441 MHz	40	2442 MHz	41	2443 MHz
42	2444 MHz	43	2445 MHz	44	2446 MHz
45	2447 MHz	46	2448 MHz	47	2449 MHz
48	2450 MHz	49	2451 MHz	50	2452 MHz
51	2453 MHz	52	2454 MHz	53	2455 MHz
54	2456 MHz	55	2457 MHz	56	2458 MHz
57	2459 MHz	58	2460 MHz	59	2461 MHz
60	2462 MHz	61	2463 MHz	62	2464 MHz
63	2465 MHz	64	2466 MHz	65	2467 MHz
66	2468 MHz	67	2469 MHz	68	2470 MHz
69	2471 MHz	70	2472 MHz	71	2473 MHz
72	2474 MHz	73	2475 MHz	74	2476 MHz
75	2477 MHz	76	2478 MHz	77	2479 MHz
78	2480 MHz	-	-	-	-

2.4. Pseudorandom Frequency Hopping Sequence

The pseudorandom sequence may be generated in a nine-stage shift register whose 5th and 9th stage outputs are added in a modulo-two addition stage. And the result is fed back to the input of the first stage. The sequence begins with the first ONE of 9 consecutive ONES; i.e. the shift register is initialized with nine ones.

- Number of shift register stages: 9
- Length of pseudo-random sequence: $2^9 - 1 = 511$ bits
- Longest sequence of zeros: 8 (non-inverted signal)

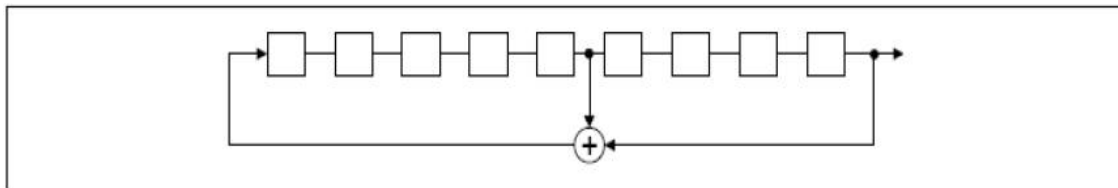

Linear Feedback Shift Register for Generation of the PRBS sequence

An example of Pseudorandom Frequency Hopping Sequence as follow:

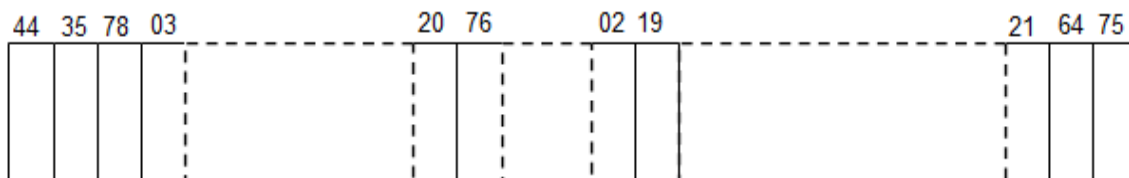

Each frequency used equally on the average by each transmitter.

The system receivers have input bandwidths that match the hopping channel bandwidths of their Corresponding transmitters and shift frequencies in synchronization with the transmitted signals.

2.5. Device Capabilities

This device contains the following capabilities:

5GHz WLAN (NII), 2.4GHz WLAN (DTS), Bluetooth v5.0 (DTS / DSS)

2.6. Test Configuration

The device was tested per the guidance of ANSI C63.10-2013. ANSI C63.10-2013 was used to reference the appropriate EUT setup for radiated spurious emissions testing and AC line conducted testing.

2.7. Test Software

The test utility software used during testing was “QCARCT”, and the version was “v3.0.210.0”.

Power Parameter Value:

Test Mode	Test Frequency (MHz)	Power Parameter Value	Test Mode	Test Frequency (MHz)	Power Parameter Value
DH5	2402	8	3DH5	2402	9
	2441	8		2441	9
	2480	8		2480	9
2DH5	2402	9	--		
	2441	9			
	2480	9			

2.8. EMI Suppression Device(s)/Modifications

No EMI suppression device(s) were added and/or no modifications were made during testing.

2.9. Labeling Requirements

Per 2.1074 & 15.19; Docket 95-19

The label shall be permanently affixed at a conspicuous location on the device; instruction manual or pamphlet supplied to the user and be readily visible to the purchaser at the time of purchase.

However, when the device is so small wherein placement of the label with specified statement is not practical, only the FCC ID must be displayed on the device per Section 15.19(a)(5). Please see attachment for FCC ID label and label location.

RSP-100 Issue 11 Section 3

The manufacturer, importer or distributor shall meet the labelling requirements set out in this section for every unit:

- (i) prior to marketing in Canada, for products manufactured in Canada
- (ii) prior to importation into Canada, for imported products

For information regarding the e-labelling option, see Notice 2014–DRS1003. The label for the certified product represents the manufacturer’s or importer’s compliance with Innovation, Science and Economic Development Canada’s (ISED) regulatory requirements.

Please see attachment for IC label and label location.

3. DESCRIPTION of TEST

3.1. Evaluation Procedure

The measurement procedures described in the American National Standard for Testing Unlicensed Wireless Devices (ANSI C63.10-2013), and were used in the measurement of the device.

Deviation from measurement procedure.....None

3.2. AC Line Conducted Emissions

The line-conducted facility is located inside an 8'x4'x4' shielded enclosure. A 1m x 2m wooden table 80cm high is placed 40cm away from the vertical wall and 80cm away from the sidewall of the shielded room. Two 10kHz-30MHz, 50Ω/50uH Line-Impedance Stabilization Networks (LISNs) are bonded to the shielded room floor. Power to the LISNs is filtered by external high-current high-insertion loss power line filters. These filters attenuate ambient signal noise from entering the measurement lines. These filters are also bonded to the shielded enclosure.

The EUT is powered from one LISN and the support equipment is powered from the second LISN. All interconnecting cables more than 1 meter were shortened to a 1 meter length by non-inductive bundling (serpentine fashion) and draped over the back edge of the test table. All cables were at least 40cm above the horizontal reference ground-plane. Power cables for support equipment were routed down to the second LISN while ensuring that that cables were not draped over the second LISN.

Sufficient time for the EUT, support equipment, and test equipment was allowed in order for them to warm up to their normal operating condition. The RF output of the LISN was connected to the receiver and exploratory measurements were made to determine the frequencies producing the maximum emission from the EUT. The receiver was scanned from 150kHz to 30MHz. The detector function was set to peak mode for exploratory measurements while the bandwidth of the analyzer was set to 9kHz. The EUT, support equipment, and interconnecting cables were arranged and manipulated to maximize each emission. Each emission was also maximized by varying: power lines, the mode of operation or data exchange speed, or support equipment whichever determined the worst-case emission. Once the worst case emissions have been identified, the one EUT cable configuration/arrangement and mode of operation that produced these emissions were used for final measurements on the same test site. The analyzer is set to CISPR quasi-peak and average detectors with a 9kHz resolution bandwidth for final measurements.

An extension cord was used to connect to a single LISN which powered by EUT. The extension cord was calibrated with LISN, the impedance and insertion loss are compliance with the requirements as stated in ANSI C63.10-2013.

3.3. Radiated Emissions

The radiated test facilities consisted of an indoor 3 meter semi-anechoic chamber used for final measurements and exploratory measurements, when necessary. The measurement area is contained within the semi-anechoic chamber which is shielded from any ambient interference. For measurements above 1GHz absorbers are arranged on the floor between the turn table and the antenna mast in such a way so as to maximize the reduction of reflections. For measurements below 1GHz, the absorbers are removed. An MF Model 210SS turntable is used for radiated measurement. It is a continuously rotatable, remote controlled, metallic turntable and 2 meters (6.56 ft.) in diameter. The turn table is flush with the raised floor of the chamber in order to maintain its function as a ground plane. An 80cm high PVC support structure is placed on top of the turntable.

For all measurements, the spectrum was scanned through all EUT azimuths and from 1 to 4 meter receive antenna height using a broadband antenna from 30MHz up to the upper frequency shown in 15.33(b)(1) depending on the highest frequency generated or used in the device or on which the device operates or tunes. For frequencies above 1GHz, linearly polarized double ridge horn antennas were used. For frequencies below 30MHz, a calibrated loop antenna was used. When exploratory measurements were necessary, they were performed at 1 meter test distance inside the semi-anechoic chamber using broadband antennas, broadband amplifiers, and spectrum analyzers to determine the frequencies and modes producing the maximum emissions. Sufficient time for the EUT, support equipment, and test equipment was allowed in order for them to warm up to their normal operating condition. The test set-up for frequencies below 1GHz was placed on top of the 0.8 meter high, 1 x 1.5 meter table; and test set-up for frequencies 1-40GHz was placed on top of the 1.5 meter high, 1 x 1.5 meter table. The EUT, support equipment, and interconnecting cables were arranged and manipulated to maximize each emission. Appropriate precaution was taken to ensure that all emissions from the EUT were maximized and investigated. The system configuration, clock speed, mode of operation or video resolution, if applicable, turntable azimuth, and receive antenna height was noted for each frequency found.

Final measurements were made in the semi-anechoic chamber using calibrated, linearly polarized broadband and horn antennas. The test setup was configured to the setup that produced the worst case emissions. The spectrum analyzer was set to investigate all frequencies required for testing to compare the highest radiated disturbances with respect to the specified limits. The turntable containing the EUT was rotated through 360 degrees and the height of the receive antenna was varied 1 to 4 meters and stopped at the azimuth and height producing the maximum emission. Each emission was maximized by changing the orientation of the EUT through three orthogonal planes and changing the polarity of the receive antenna, whichever produced the worst-case emissions. According to 3dB Beamwidth of horn antenna, the horn antenna should be always directed to the EUT when rising height.

4. ANTENNA REQUIREMENTS

Excerpt from §15.203 of the FCC Rules/Regulations:

“An intentional radiator antenna shall be designed to ensure that no antenna other than that furnished by the responsible party can be used with the device. The use of a permanently attached antenna or of an antenna that uses a unique coupling to the intentional radiator shall be considered sufficient to comply with the provisions of this section.”

- The antenna of the device uses a unique connector.

Antenna Type	Antenna connector Type
PIFA Antenna	IPEX connector

Conclusion:

The unit complies with the requirement of §15.203.

5. TEST EQUIPMENT CALIBRATION DATE

Conducted Emissions - SR2

Instrument	Manufacturer	Type No.	Asset No.	Cali. Interval	Cali. Due Date
EMI Test Receiver	R&S	ESR3	MRTSUE06185	1 year	2020/04/15
Two-Line V-Network	R&S	ENV 216	MRTSUE06002	1 year	2019/06/14
Two-Line V-Network	R&S	ENV 216	MRTSUE06003	1 year	2019/06/14
Thermohygrometer	Testo	608-H1	MRTSUE06404	1 year	2019/08/14
Shielding Anechoic Chamber	MIX-BEP	Chamber-SR2	MRTSUE06214	N/A	N/A

Radiated Emissions - AC1

Instrument	Manufacturer	Type No.	Asset No.	Cali. Interval	Cali. Due Date
EMI Test Receiver	R&S	ESR7	MRTSUE06001	1 year	2019/08/13
PXA Signal Analyzer	Keysight	9030B	MRTSUE06395	1 year	2019/09/25
Loop Antenna	Schwarzbeck	FMZB 1519	MRTSUE06025	1 year	2019/11/09
Bilog Period Antenna	Schwarzbeck	VULB 9168	MRTSUE06172	1 year	2020/03/31
Broad Band Horn Antenna	Schwarzbeck	BBHA 9120D	MRTSUE06023	1 year	2019/10/19
Broad Band Horn Antenna	Schwarzbeck	BBHA 9170	MRTSUE06024	1 year	2019/12/17
Microwave System Amplifier	Agilent	83017A	MRTSUE06076	1 year	2019/11/16
Preamplifier	Schwarzbeck	BBV 9721	MRTSUE06121	1 year	2019/06/12
Thermohygrometer	Testo	608-H1	MRTSUE06403	1 year	2019/08/14
Anechoic Chamber	TDK	Chamber-AC1	MRTSUE06213	1 year	2020/04/30

Radiated Emission - AC2

Instrument	Manufacturer	Type No.	Asset No.	Cali. Interval	Cali. Due Date
Spectrum Analyzer	Keysight	N9038A	MRTSUE06125	1 year	2019/08/13
Loop Antenna	Schwarzbeck	FMZB 1519	MRTSUE06025	1 year	2019/11/09
Bilog Period Antenna	Schwarzbeck	VULB 9162	MRTSUE06022	1 year	2019/10/19
Horn Antenna	Schwarzbeck	BBHA9120D	MRTSUE06171	1 year	2019/11/09
Broad Band Horn Antenna	Schwarzbeck	BBHA 9170	MRTSUE06024	1 year	2019/12/17
Broadband Coaxial Preamplifier	Schwarzbeck	BBV 9718	MRTSUE06176	1 year	2019/11/16
Preamplifier	Schwarzbeck	BBV 9721	MRTSUE06121	1 year	2019/06/12
Temperature/Humidity Meter	Minggao	ETH529	MRTSUE06170	1 year	2019/12/13
Anechoic Chamber	RIKEN	Chamber-AC2	MRTSUE06213	1 year	2020/04/30

Conducted Test Equipment - TR3

Instrument	Manufacturer	Type No.	Asset No.	Cali. Interval	Cali. Due Date
EXA Signal Analyzer	Agilent	N9020A	MRTSUE06106	1 year	2020/04/15
EXA Signal Analyzer	Keysight	N9010B	MRTSUE06452	1 year	2019/07/19
Power Meter	Agilent	U2021XA	MRTSUE06030	1 year	2019/11/16
USB wideband power sensor	Keysight	U2021XA	MRTSUE06446	1 year	2019/07/19
USB wideband power sensor	Keysight	U2021XA	MRTSUE06447	1 year	2019/07/05
DC Power Supply	GWINSTEK	DPS-3303C	MRTSUE06064	N/A	N/A
Temperature & Humidity Chamber	BAOYT	BYH-150CL	MRTSUE06051	1 year	2019/11/16
Thermohygrometer	testo	608-H1	MRTSUE06401	1 year	2019/08/14

Software	Version	Function
EMI Software	V3	EMI Test Software

6. MEASUREMENT UNCERTAINTY

Where relevant, the following test uncertainty levels have been estimated for tests performed on the EUT as specified in CISPR 16-4-2. This uncertainty represents an expanded uncertainty expressed at approximately the 95% confidence level using a coverage factor of $k = 2$.

AC Conducted Emission Measurement - SR2
Measuring Uncertainty for a Level of Confidence of 95% ($U=2Uc(y)$): 150kHz~30MHz: 3.46dB
Radiated Emission Measurement – AC1
Measuring Uncertainty for a Level of Confidence of 95% ($U=2Uc(y)$): 9kHz ~ 1GHz: 4.18dB 1GHz ~ 25GHz: 4.76dB
Radiated Emission Measurement – AC2
Measuring Uncertainty for a Level of Confidence of 95% ($U=2Uc(y)$): 9kHz ~ 1GHz: 3.86dB 1GHz ~ 25GHz: 4.33dB

7. TEST RESULT

7.1. Summary

FCC Part Section(s)	IC Section(s)	Test Description	Test Limit	Test Condition	Test Result	Reference
15.247(b)(1)	RSS-247 [5.4(b)]	Peak Transmitter Output Power	Refer to section 7.2.1	Conducted	PASS	Section 7.2
15.205, 15.209	RSS-247 [5.5]	General Field Strength Limits (Restricted Bands and Radiated Emission Limits)	Refer to section 7.3.1 & 7.4.1	Radiated	PASS	Section 7.3 Section 7.4

Notes:

- 1) The correction factor was used to account for the losses of the cables and attenuators used as part of the system to connect the EUT to the power meter at all frequencies of interest.
- 2) All modes of operation and data rates were investigated. For radiated emission test, every axis (X, Y, Z) was also verified. The test results shown in the following sections represent the worst case emissions.

7.2. Output Power Measurement

7.2.1. Test Limit

The maximum out power permissible output power is 1 Watt for all other frequency hopping systems operating in the 2400-2483.5 MHz band employing at least 75 non-overlapping hopping channels.

7.2.2. Test Procedure Used

ANSI C63.10-2013 - Section 7.8.5

7.2.3. Test Setting

1. Set RBW \geq the 20 dB bandwidth of the emission being measured.
2. VBW $\geq 3 \times$ RBW
3. Span = approximately 2 to 3 times the 20dB bandwidth, centered on a hopping channel
4. Detector = Peak
5. Trace mode = max hold
6. Sweep = auto couple
7. Allow the trace to stabilize, Use the marker-to-peak function to set the marker to the peak of the emission. The indicated level is the peak output power (don't forget added the external attenuation and cable loss)

7.2.4. Test Setup

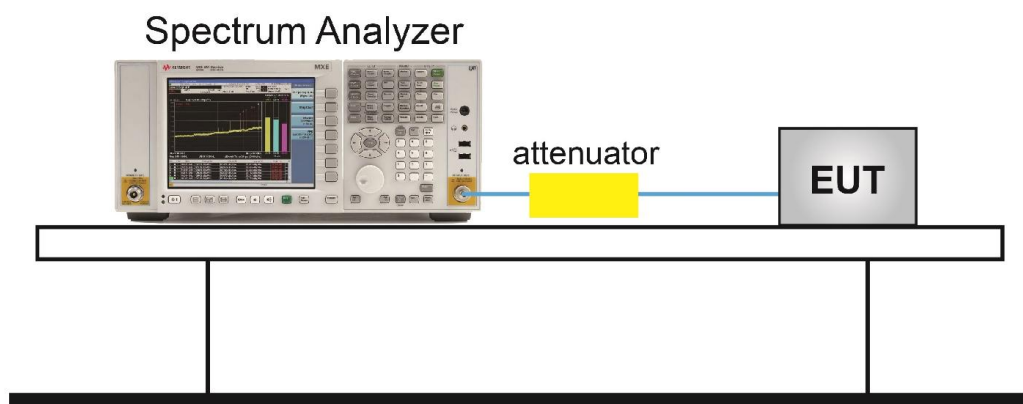

7.2.5. Test Result

Product	W-LAN + Bluetooth Module	Temperature	26°C
Test Engineer	Flag Yang	Relative Humidity	55%
Test Site	TR3	Test Date	2019/06/22

Test Mode	Channel No.	Frequency (MHz)	Peak Power (dBm)	Peak Power Limit (dBm)	EIRP (dBm)	EIRP Limit (dBm)	Result
DH5	00	2402	3.95	≤ 20.97	7.24	≤ 36.0	Pass
DH5	39	2441	4.60	≤ 20.97	7.89	≤ 36.0	Pass
DH5	78	2480	5.16	≤ 20.97	8.45	≤ 36.0	Pass
2DH5	00	2402	7.44	≤ 20.97	10.73	≤ 36.0	Pass
2DH5	39	2441	7.48	≤ 20.97	10.77	≤ 36.0	Pass
2DH5	78	2480	7.58	≤ 20.97	10.87	≤ 36.0	Pass
3DH5	00	2402	8.04	≤ 20.97	11.33	≤ 36.0	Pass
3DH5	39	2441	7.90	≤ 20.97	11.19	≤ 36.0	Pass
3DH5	78	2480	7.82	≤ 20.97	11.11	≤ 36.0	Pass

Note: EIRP (dBm) = Conducted Power (dBm) + Antenna Gain (dBi), Antenna Gain = 3.29 dBi.

DH5 Output Power

Channel 00 (2402MHz)



Channel 39 (2441MHz)



Channel 78 (2480MHz)



2DH5 Output Power

Channel 00 (2402MHz)



Channel 39 (2441MHz)



Channel 78 (2480MHz)



3DH5 Output Power

Channel 00 (2402MHz)



Channel 39 (2441MHz)



Channel 78 (2480MHz)



7.3. Radiated Spurious Emission Measurement

7.3.1. Test Limit

All out of band emissions appearing in a restricted band as specified in Section 15.205 of the Title 47 CFR must not exceed the limits shown in Table per Section 15.209.

FCC Part 15 Subpart C Paragraph 15.209		
Frequency [MHz]	Field Strength [uV/m]	Measured Distance [Meters]
0.009 - 0.490	2400/F (kHz)	300
0.490 - 1.705	24000/F (kHz)	30
1.705 - 30	30	30
30 - 88	100	3
88 - 216	150	3
216 - 960	200	3
Above 960	500	3

7.3.2. Test Procedure Used

ANSI C63.10 Section 6.3 (General Requirements)

ANSI C63.10 Section 6.4 (Standard test method below 30MHz)

ANSI C63.10 Section 6.5 (Standard test method above 30MHz to 1GHz)

ANSI C63.10 Section 6.6 (Standard test method above 1GHz)

7.3.3. Test Setting

Table 1 - RBW as a function of frequency

Frequency	RBW
9 ~ 150 kHz	200 ~ 300 Hz
0.15 ~ 30 MHz	9 ~ 10 kHz
30 ~ 1000 MHz	100 ~ 120 kHz
> 1000 MHz	1 MHz

Quasi-Peak Measurements below 1GHz

1. Analyzer center frequency was set to the frequency of the radiated spurious emission of interest
2. Span was set greater than 1MHz
3. RBW = as specified in Table 1
4. Detector = CISPR quasi-peak
5. Sweep time = auto couple
6. Trace was allowed to stabilize

Peak Measurements above 1GHz

1. Analyzer center frequency was set to the frequency of the radiated spurious emission of interest
2. RBW = 1MHz
3. VBW = 3MHz
4. Detector = peak
5. Sweep time = auto couple
6. Trace mode = max hold
7. Trace was allowed to stabilize

Average Measurements above 1GHz (Method VB)

1. Analyzer center frequency was set to the frequency of the radiated spurious emission of interest
2. RBW = 1MHz
3. VBW; If the EUT is configured to transmit with duty cycle $\geq 98\%$, set VBW = 10 Hz.

If the EUT duty cycle is $< 98\%$, set VBW $\geq 1/T$. T is the minimum transmission duration.
4. Detector = Peak
5. Sweep time = auto
6. Trace mode = max hold
7. Trace was allowed to stabilize

7.3.4. Test Setup

Below 1GHz Test Setup:

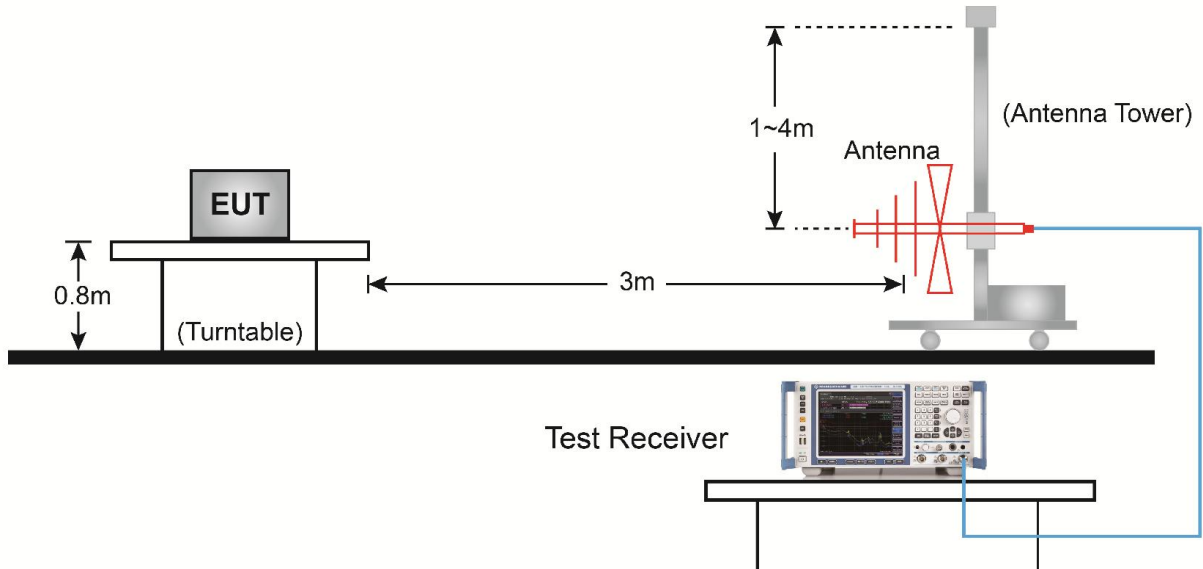

Above 1GHz Test Setup:

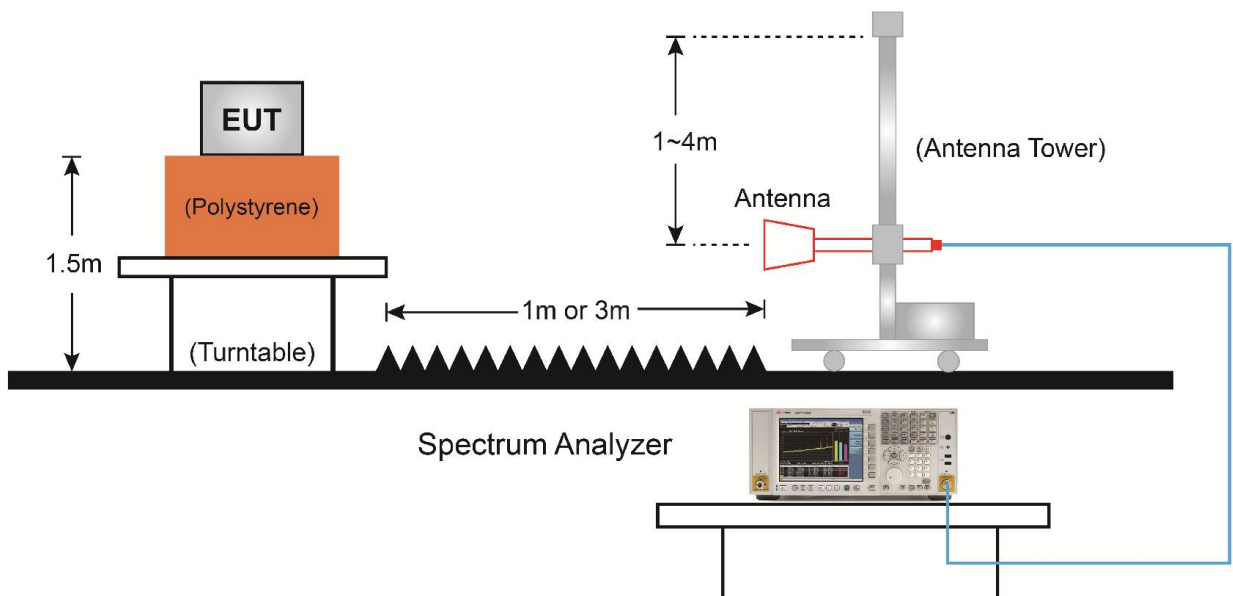

7.3.5. Test Result

Product	W-LAN + Bluetooth Module	Temperature	26°C
Test Engineer	Dandy Li	Relative Humidity	56%
Test Site	AC2	Test Date	2019/05/14
Test Mode:	DH5	Test Channel:	00
Remark:	1. Average measurement was not performed if peak level lower than average limit. 2. Other frequency was 20dB below limit line within 1-18GHz, there is not show in the report.		

Mark	Frequency (MHz)	Reading Level (dBμV)	Factor (dB)	Measure Level (dBμV/m)	Limit (dBμV/m)	Margin (dB)	Detector	Polarization
	4255.5	37.0	1.4	38.4	74.0	-35.6	Peak	Horizontal
	4808.0	46.7	3.5	50.2	74.0	-23.8	Peak	Horizontal
*	6219.0	36.2	6.7	42.9	82.6	-39.7	Peak	Horizontal
*	7205.0	35.5	11.7	47.2	82.6	-35.4	Peak	Horizontal
	4170.5	37.5	1.1	38.6	74.0	-35.4	Peak	Vertical
	4808.0	44.9	3.5	48.4	74.0	-25.6	Peak	Vertical
*	6057.5	36.1	6.1	42.2	82.6	-40.4	Peak	Vertical
*	7205.0	38.2	11.7	49.9	82.6	-32.7	Peak	Vertical

Note 1: "*" is not in restricted band, its limit is 20dBc of the fundamental emission level (102.6dBμV/m) or 15.209 which is higher.

Note 2: Measure Level (dBμV/m) = Reading Level (dBμV) + Factor (dB)

Factor (dB) = Cable Loss (dB) + Antenna Factor (dB/m) - Pre_Amplifier Gain (dB)

Product	W-LAN + Bluetooth Module	Temperature	26°C
Test Engineer	Dandy Li	Relative Humidity	56%
Test Site	AC2	Test Date	2019/05/14
Test Mode:	DH5	Test Channel:	39
Remark:	1. Average measurement was not performed if peak level lower than average limit. 2. Other frequency was 20dB below limit line within 1-18GHz, there is not show in the report.		

Mark	Frequency (MHz)	Reading Level (dBμV)	Factor (dB)	Measure Level (dBμV/m)	Limit (dBμV/m)	Margin (dB)	Detector	Polarization
	4884.5	46.5	3.5	50.0	74.0	-24.0	Peak	Horizontal
	7324.0	38.0	12.0	50.0	74.0	-24.0	Peak	Horizontal
*	9763.5	35.7	14.0	49.7	82.8	-33.1	Peak	Horizontal
*	10358.5	32.4	16.1	48.5	82.8	-34.3	Peak	Horizontal
	4884.5	43.6	3.5	47.1	74.0	-26.9	Peak	Vertical
	7324.0	37.0	12.0	49.0	74.0	-25.0	Peak	Vertical
*	9763.5	37.0	14.0	51.0	82.8	-31.8	Peak	Vertical
*	10375.5	33.4	16.1	49.5	82.8	-33.3	Peak	Vertical

Note 1: "*" is not in restricted band, its limit is 20dBc of the fundamental emission level (102.8dBμV/m) or 15.209 which is higher.

Note 2: Measure Level (dBμV/m) = Reading Level (dBμV) + Factor (dB)

Factor (dB) = Cable Loss (dB) + Antenna Factor (dB/m) - Pre_Amplifier Gain (dB)

Product	W-LAN + Bluetooth Module	Temperature	26°C
Test Engineer	Dandy Li	Relative Humidity	56%
Test Site	AC2	Test Date	2019/05/14
Test Mode:	DH5	Test Channel:	78
Remark:	1. Average measurement was not performed if peak level lower than average limit. 2. Other frequency was 20dB below limit line within 1-18GHz, there is not show in the report.		

Mark	Frequency (MHz)	Reading Level (dBμV)	Factor (dB)	Measure Level (dBμV/m)	Limit (dBμV/m)	Margin (dB)	Detector	Polarization
	4961.0	46.5	3.5	50.0	74.0	-24.0	Peak	Horizontal
	7443.0	36.3	11.8	48.1	74.0	-25.9	Peak	Horizontal
*	9602.0	34.3	13.6	47.9	82.9	-35.0	Peak	Horizontal
*	10341.5	33.6	16.0	49.6	82.9	-33.3	Peak	Horizontal
	4961.0	42.8	3.5	46.3	74.0	-27.7	Peak	Vertical
	7443.0	37.5	11.8	49.3	74.0	-24.7	Peak	Vertical
*	8726.5	32.7	12.8	45.5	82.9	-37.4	Peak	Vertical
*	9916.5	35.2	14.1	49.3	82.9	-33.6	Peak	Vertical

Note 1: "*" is not in restricted band, its limit is 20dBc of the fundamental emission level (102.9dBμV/m) or 15.209 which is higher.

Note 2: Measure Level (dBμV/m) = Reading Level (dBμV) + Factor (dB)

Factor (dB) = Cable Loss (dB) + Antenna Factor (dB/m) - Pre_Amplifier Gain (dB)

Product	W-LAN + Bluetooth Module	Temperature	26°C
Test Engineer	Dandy Li	Relative Humidity	56%
Test Site	AC2	Test Date	2019/05/14
Test Mode:	2DH5	Test Channel:	00
Remark:	1. Average measurement was not performed if peak level lower than average limit. 2. Other frequency was 20dB below limit line within 1-18GHz, there is not show in the report.		

Mark	Frequency (MHz)	Reading Level (dBμV)	Factor (dB)	Measure Level (dBμV/m)	Limit (dBμV/m)	Margin (dB)	Detector	Polarization
	4808.0	44.2	3.5	47.7	74.0	-26.3	Peak	Horizontal
	7570.5	33.3	11.6	44.9	74.0	-29.1	Peak	Horizontal
*	9593.5	35.4	13.6	49.0	85.9	-36.9	Peak	Horizontal
*	10426.5	33.8	16.0	49.8	85.9	-36.1	Peak	Horizontal
	4808.0	41.9	3.5	45.4	74.0	-28.6	Peak	Vertical
	7553.5	35.1	11.8	46.9	74.0	-27.1	Peak	Vertical
*	9670.0	34.2	13.6	47.8	85.9	-38.1	Peak	Vertical
*	10384.0	33.8	16.3	50.1	85.9	-35.8	Peak	Vertical

Note 1: "*" is not in restricted band, its limit is 20dBc of the fundamental emission level (105.9dBμV/m) or 15.209 which is higher.

Note 2: Measure Level (dBμV/m) = Reading Level (dBμV) + Factor (dB)

Factor (dB) = Cable Loss (dB) + Antenna Factor (dB/m) - Pre_Amplifier Gain (dB)

Product	W-LAN + Bluetooth Module	Temperature	26°C
Test Engineer	Dandy Li	Relative Humidity	56%
Test Site	AC2	Test Date	2019/05/14
Test Mode:	2DH5	Test Channel:	39
Remark:	1. Average measurement was not performed if peak level lower than average limit. 2. Other frequency was 20dB below limit line within 1-18GHz, there is not show in the report.		

Mark	Frequency (MHz)	Reading Level (dBμV)	Factor (dB)	Measure Level (dBμV/m)	Limit (dBμV/m)	Margin (dB)	Detector	Polarization
	4884.5	43.1	3.5	46.6	74.0	-27.4	Peak	Horizontal
	7604.5	33.1	11.4	44.5	74.0	-29.5	Peak	Horizontal
*	9636.0	33.3	13.7	47.0	85.8	-38.8	Peak	Horizontal
*	10129.0	34.2	15.3	49.5	85.8	-36.3	Peak	Horizontal
	4884.5	40.9	3.5	44.4	74.0	-29.6	Peak	Vertical
	8854.0	31.2	12.6	43.8	74.0	-30.2	Peak	Vertical
*	9610.5	34.1	13.5	47.6	85.8	-38.2	Peak	Vertical
*	10358.5	33.7	16.1	49.8	85.8	-36.0	Peak	Vertical

Note 1: "*" is not in restricted band, its limit is 20dBc of the fundamental emission level (105.8dBμV/m) or 15.209 which is higher.

Note 2: Measure Level (dBμV/m) = Reading Level (dBμV) + Factor (dB)

Factor (dB) = Cable Loss (dB) + Antenna Factor (dB/m) - Pre_Amplifier Gain (dB)

Product	W-LAN + Bluetooth Module	Temperature	26°C
Test Engineer	Dandy Li	Relative Humidity	56%
Test Site	AC2	Test Date	2019/05/14
Test Mode:	2DH5	Test Channel:	78
Remark:	1. Average measurement was not performed if peak level lower than average limit. 2. Other frequency was 20dB below limit line within 1-18GHz, there is not show in the report.		

Mark	Frequency (MHz)	Reading Level (dBμV)	Factor (dB)	Measure Level (dBμV/m)	Limit (dBμV/m)	Margin (dB)	Detector	Polarization
	4961.0	43.5	3.5	47.0	74.0	-27.0	Peak	Horizontal
	7443.0	34.5	11.8	46.3	74.0	-27.7	Peak	Horizontal
*	9755.0	34.2	14.0	48.2	85.6	-37.4	Peak	Horizontal
*	10316.0	34.3	15.6	49.9	85.6	-35.7	Peak	Horizontal
	4961.0	41.1	3.5	44.6	74.0	-29.4	Peak	Vertical
	7332.5	34.4	11.8	46.2	74.0	-27.8	Peak	Vertical
*	9593.5	34.1	13.6	47.7	85.6	-37.9	Peak	Vertical
*	10222.5	34.1	15.1	49.2	85.6	-36.4	Peak	Vertical

Note 1: "*" is not in restricted band, its limit is 20dBc of the fundamental emission level (105.6dBμV/m) or 15.209 which is higher.

Note 2: Measure Level (dBμV/m) = Reading Level (dBμV) + Factor (dB)

Factor (dB) = Cable Loss (dB) + Antenna Factor (dB/m) - Pre_Amplifier Gain (dB)

Product	W-LAN + Bluetooth Module	Temperature	26°C
Test Engineer	Dandy Li	Relative Humidity	56%
Test Site	AC2	Test Date	2019/05/14
Test Mode:	3DH5	Test Channel:	00
Remark:	1. Average measurement was not performed if peak level lower than average limit. 2. Other frequency was 20dB below limit line within 1-18GHz, there is not show in the report.		

Mark	Frequency (MHz)	Reading Level (dBμV)	Factor (dB)	Measure Level (dBμV/m)	Limit (dBμV/m)	Margin (dB)	Detector	Polarization
	4808.0	44.9	3.5	48.4	74.0	-25.6	Peak	Horizontal
	7579.0	33.4	11.5	44.9	74.0	-29.1	Peak	Horizontal
*	9916.5	34.6	14.1	48.7	86.5	-37.8	Peak	Horizontal
*	10367.0	33.6	16.0	49.6	86.5	-36.9	Peak	Horizontal
	4799.5	42.3	3.5	45.8	74.0	-28.2	Peak	Vertical
	7434.5	35.0	11.8	46.8	74.0	-27.2	Peak	Vertical
*	9670.0	34.9	13.6	48.5	86.5	-38.0	Peak	Vertical
*	10452.0	34.2	16.4	50.6	86.5	-35.9	Peak	Vertical

Note 1: "*" is not in restricted band, its limit is 20dBc of the fundamental emission level (106.5dBμV/m) or 15.209 which is higher.

Note 2: Measure Level (dBμV/m) = Reading Level (dBμV) + Factor (dB)

Factor (dB) = Cable Loss (dB) + Antenna Factor (dB/m) - Pre_Amplifier Gain (dB)

Product	W-LAN + Bluetooth Module	Temperature	26°C
Test Engineer	Dandy Li	Relative Humidity	56%
Test Site	AC2	Test Date	2019/05/14
Test Mode:	3DH5	Test Channel:	39
Remark:	1. Average measurement was not performed if peak level lower than average limit. 2. Other frequency was 20dB below limit line within 1-18GHz, there is not show in the report.		

Mark	Frequency (MHz)	Reading Level (dBμV)	Factor (dB)	Measure Level (dBμV/m)	Limit (dBμV/m)	Margin (dB)	Detector	Polarization
	4884.5	43.2	3.5	46.7	74.0	-27.3	Peak	Horizontal
	7502.5	34.8	11.8	46.6	74.0	-27.4	Peak	Horizontal
*	9763.5	33.4	14.0	47.4	86.4	-39.0	Peak	Horizontal
*	10095.0	34.0	14.7	48.7	86.4	-37.7	Peak	Horizontal
	4884.5	41.9	3.5	45.4	74.0	-28.6	Peak	Vertical
	7553.5	34.2	11.8	46.0	74.0	-28.0	Peak	Vertical
*	9755.0	34.2	14.0	48.2	86.4	-38.2	Peak	Vertical
*	10375.5	33.8	16.1	49.9	86.4	-36.5	Peak	Vertical

Note 1: "*" is not in restricted band, its limit is 20dBc of the fundamental emission level (106.4dBμV/m) or 15.209 which is higher.

Note 2: Measure Level (dBμV/m) = Reading Level (dBμV) + Factor (dB)

Factor (dB) = Cable Loss (dB) + Antenna Factor (dB/m) - Pre_Amplifier Gain (dB)

Product	W-LAN + Bluetooth Module	Temperature	26°C
Test Engineer	Dandy Li	Relative Humidity	56%
Test Site	AC2	Test Date	2019/05/14
Test Mode:	3DH5	Test Channel:	78
Remark:	1. Average measurement was not performed if peak level lower than average limit. 2. Other frequency was 20dB below limit line within 1-18GHz, there is not show in the report.		

Mark	Frequency (MHz)	Reading Level (dBμV)	Factor (dB)	Measure Level (dBμV/m)	Limit (dBμV/m)	Margin (dB)	Detector	Polarization
	4961.0	43.5	3.5	47.0	74.0	-27.0	Peak	Horizontal
	7519.5	34.6	11.6	46.2	74.0	-27.8	Peak	Horizontal
*	9585.0	34.4	13.6	48.0	85.8	-37.8	Peak	Horizontal
*	10384.0	33.4	16.3	49.7	85.8	-36.1	Peak	Horizontal
	4961.0	40.1	3.5	43.6	74.0	-30.4	Peak	Vertical
	7434.5	32.9	11.8	44.7	74.0	-29.3	Peak	Vertical
*	9772.0	34.0	14.0	48.0	85.8	-37.8	Peak	Vertical
*	10401.0	33.4	16.3	49.7	85.8	-36.1	Peak	Vertical

Note 1: "*" is not in restricted band, its limit is 20dBc of the fundamental emission level (105.8dBμV/m) or 15.209 which is higher.

Note 2: Measure Level (dBμV/m) = Reading Level (dBμV) + Factor (dB)

Factor (dB) = Cable Loss (dB) + Antenna Factor (dB/m) - Pre_Amplifier Gain (dB)

The Worst Case of Radiated Emission below 1GHz:

Site: AC2	Time: 2019/05/23 - 15:00
Limit: FCC_Part15.209_RSE(3m)	Engineer: Dandy Li
Probe: VULB9162_0.03-8GHz	Polarity: Horizontal
EUT: W-LAN + Bluetooth Module	Power: DC 3.3V

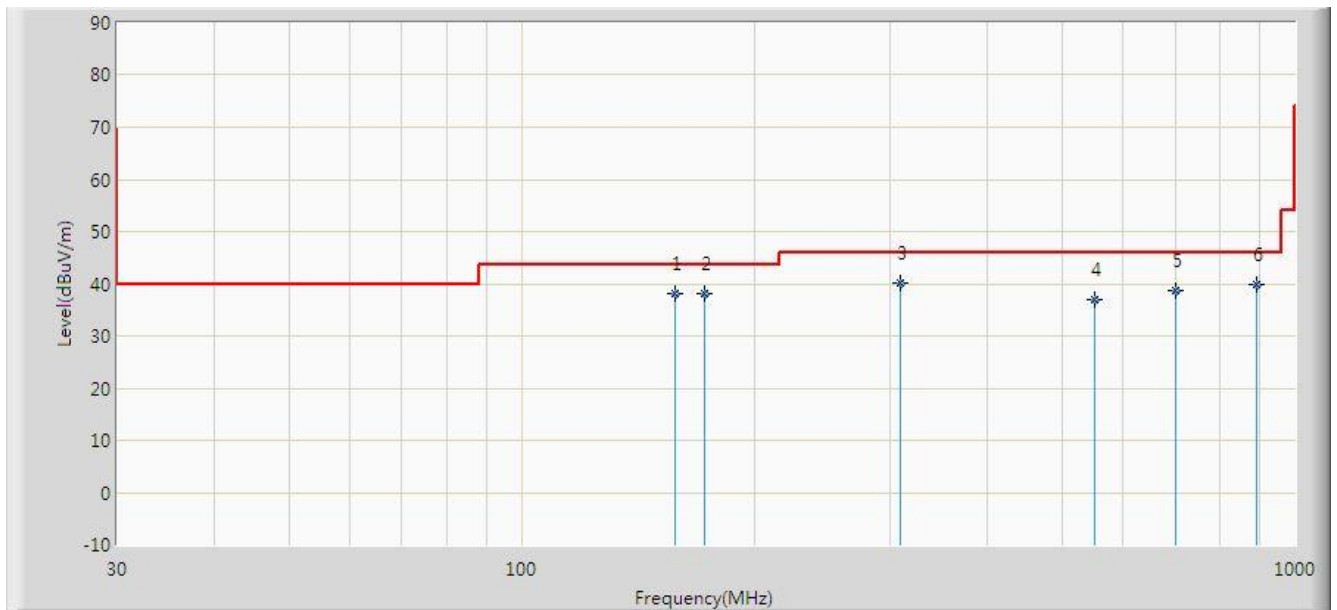
Worst case Mode: Transmit by DH5 at channel 2441MHz

No	Flag	Mark	Frequency (MHz)	Measure Level (dBuV/m)	Reading Level (dBuV)	Over Limit (dB)	Limit (dBuV/m)	Factor (dB)	Type
1			158.040	38.036	28.439	-5.464	43.500	9.597	QP
2		*	172.105	38.186	27.992	-5.314	43.500	10.194	QP
3			308.875	40.185	25.649	-5.815	46.000	14.536	QP
4			549.920	37.068	18.287	-8.932	46.000	18.781	QP
5			699.785	38.809	17.655	-7.191	46.000	21.154	QP
6			890.875	39.955	16.424	-6.045	46.000	23.531	QP

Note 1: Measure Level (dB μ V/m) = Reading Level (dB μ V) + Factor (dB)

Factor (dB) = Cable Loss (dB) + Antenna Factor (dB/m)

Note 2: The test trace is same as the ambient noise and the amplitude of the emissions are attenuated more than 20dB below the permissible (the test frequency range: 9kHz ~ 30MHz, 18GHz ~ 25GHz), therefore no data appear in the report.

Site: AC2	Time: 2019/05/23 - 15:00
Limit: FCC_Part15.209_RSE(3m)	Engineer: Dandy Li
Probe: VULB9162_0.03-8GHz	Polarity: Vertical
EUT: W-LAN + Bluetooth Module	Power: DC 3.3V
Worst case Mode: Transmit by DH5 at channel 2441MHz	

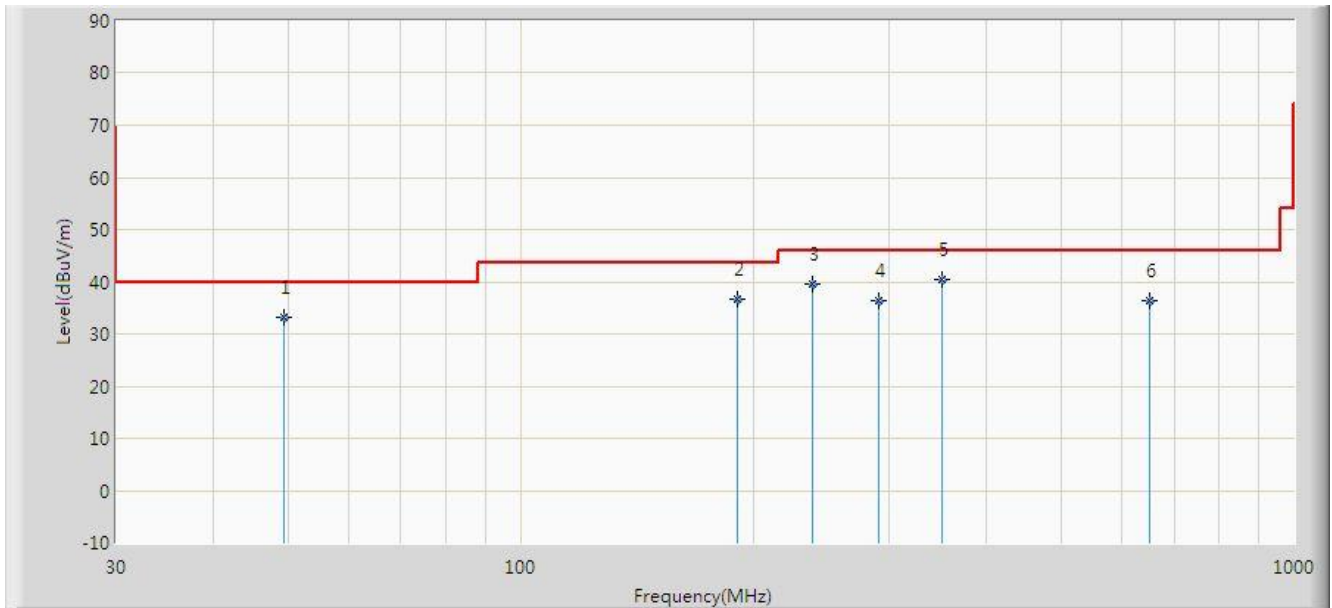

No	Flag	Mark	Frequency (MHz)	Measure Level (dBuV/m)	Reading Level (dBuV)	Over Limit (dB)	Limit (dBuV/m)	Factor (dB)	Type
1			49.400	33.190	18.337	-6.810	40.000	14.853	QP
2			191.020	36.650	24.983	-6.850	43.500	11.667	QP
3			238.065	39.560	26.421	-6.440	46.000	13.139	QP
4			289.960	36.269	22.151	-9.731	46.000	14.118	QP
5		*	350.100	40.571	25.002	-5.429	46.000	15.568	QP
6			649.830	36.278	16.009	-9.722	46.000	20.270	QP

Note 1: Measure Level (dBuV/m) = Reading Level (dBuV) + Factor (dB)

Factor (dB) = Cable Loss (dB) + Antenna Factor (dB/m)

Note 2: The test trace is same as the ambient noise and the amplitude of the emissions are attenuated more than 20dB below the permissible (the test frequency range: 9kHz ~ 30MHz, 18GHz ~ 25GHz), therefore no data appear in the report.

7.4. Radiated Restricted Band Edge Measurement

7.4.1. Test Limit

For 15.205 requirement:

Radiated emissions which fall in the restricted bands, as defined in Section 15.205(a) of FCC part 15, must also comply with the radiated emission limits specified in Section 15.209(a).

Frequency (MHz)	Frequency (MHz)	Frequency (MHz)	Frequency (GHz)
0.090 - 0.110	16.42 - 16.423	399.9 - 410	4.5 - 5.15
¹ 0.495 - 0.505	16.69475 - 16.69525	608 - 614	5.35 - 5.46
2.1735 - 2.1905	16.80425 - 16.80475	960 - 1240	7.25 - 7.75
4.125 - 4.128	25.5 - 25.67	1300 - 1427	8.025 - 8.5
4.17725 - 4.17775	37.5 - 38.25	1435 - 1626.5	9.0 - 9.2
4.20725 - 4.20775	73 - 74.6	1645.5 - 1646.5	9.3 - 9.5
6.215 - 6.218	74.8 - 75.2	1660 - 1710	10.6 - 12.7
6.26775 - 6.26825	108 - 121.94	1718.8 - 1722.2	13.25 - 13.4
6.31175 - 6.31225	123 - 138	2200 - 2300	14.47 - 14.5
8.291 - 8.294	149.9 - 150.05	2310 - 2390	15.35 - 16.2
8.362 - 8.366	156.52475 - 156.525	2483.5 - 2500	17.7 - 21.4
8.37625 - 8.38675	156.7 - 156.9	2690 - 2900	22.01 - 23.12
8.41425 - 8.41475	162.0125 - 167.17	3260 - 3267	23.6 - 24.0
12.29 - 12.293	167.72 - 173.2	3332 - 3339	31.2 - 31.8
12.51975 - 12.52025	240 - 285	3345.8 - 3358	36.43 - 36.5
12.57675 - 12.57725	322 - 335.4	3600 - 4400	(²)
13.36 - 13.41	--	--	--

All out of band emissions appearing in a restricted band as specified in Section 15.205 of the Title 47CFR must not exceed the limits shown in Table per Section 15.209.

FCC Part 15 Subpart C Paragraph 15.209		
Frequency [MHz]	Field Strength [uV/m]	Measured Distance [Meters]
0.009 - 0.490	2400/F (kHz)	300
0.490 - 1.705	24000/F (kHz)	30
1.705 - 30	30	30
30 - 88	100	3
88 - 216	150	3
216 - 960	200	3
Above 960	500	3

For RSS-Gen Section 8.10 requirement:

Radiated emissions which fall in the restricted bands, as defined in Section 8.10 of RSS-Gen, must also comply with the radiated emission limits specified in Section 8.9.

Frequency (MHz)	Frequency (MHz)	Frequency (GHz)
0.090 - 0.110	149.9 -150.5	9.0 - 9.2
0.495 -0.505	156.52475 - 156.525225	9.3 - 9.5
2.1735 - 2.1905	156.7 - 156.9	10.6 - 12.7
3.020 - 3.026	162.0125 - 167.17	13.25 - 13.4
4.125 - 4.128	167.72 - 173.2	14.47 - 14.5
4.17725 - 4.17775	240 - 285	15.35 - 16.2
4.20725 - 4.20775	322 - 335.4	17.7 - 21.4
5.677 - 5.683	399.9 - 410	22.01 - 23.12
6.215 - 6.218	608 - 614	23.6 - 24.0
6.26775 - 6.26825	960 - 1427	31.2 - 31.8
6.31175 - 6.31225	1435 - 1626.5	36.43 - 36.5
8.291 - 8.294	1645.5 - 1646.5	Above 38.6
8.362 - 8.366	1660 - 1710	--
8.37625 - 8.38675	1718.8 -1722.2	
8.41425 - 8.41475	2200 - 2300	
12.29 - 12.293	2310 -2390	
12.51975 - 12.52025	2483.5 - 2500	
12.57675 - 12.57725	2655 - 2900	
13.36 -13.41	3260 - 3267	
16.42 - 16.423	3332 -3339	
16.69475 - 16.69525	334.5 - 3358	
16.80425 - 16.80475	3500 - 4400	
25.5 - 25.67	4500 - 5150	
37.5 - 38.25	5350 - 5460	
73 - 74.6	7250 - 7750	
74.8 - 75.2	8025 - 8500	
108 - 138	--	

All out of band emissions appearing in a restricted band as specified in Section 8.10 of the RSS-Gen must not exceed the limits shown in Table per Section 8.9.

RSS-Gen Section 8.9			
Frequency [MHz]	Magnetic field strength (H-Field) [uA/m]	Field Strength [uV/m]	Measured Distance [Meters]
0.009 - 0.490	6.37/F(F in kHz)	--	300
0.490 - 1.705	63.7/F(F in kHz)	--	30
1.705 - 30	0.08	--	30
30 - 88	--	100	3
88 - 216	--	150	3
216 - 960	--	200	3
Above 960	--	500	3

7.4.2. Test Procedure Used

ANSI C63.10 Section 6.3 (General Requirements)

ANSI C63.10 Section 6.6 (Standard test method above 1GHz)

7.4.3. Test Setting

Peak Field Strength Measurements

1. Analyzer center frequency was set to the frequency of the radiated spurious emission of interest
2. RBW = 1MHz
3. VBW = 3MHz
4. Detector = peak
5. Sweep time = auto couple
6. Trace mode = max hold
7. Trace was allowed to stabilize

Average Measurements above 1GHz (Method VB)

1. Analyzer center frequency was set to the frequency of the radiated spurious emission of interest
2. RBW = 1MHz
3. VBW; If the EUT is configured to transmit with duty cycle $\geq 98\%$, set VBW = 10 Hz.

If the EUT duty cycle is $< 98\%$, set VBW $\geq 1/T$. T is the minimum transmission duration.

4. Detector = Peak
5. Sweep time = auto
6. Trace mode = max hold
7. Trace was allowed to stabilize

7.4.4. Test Setup

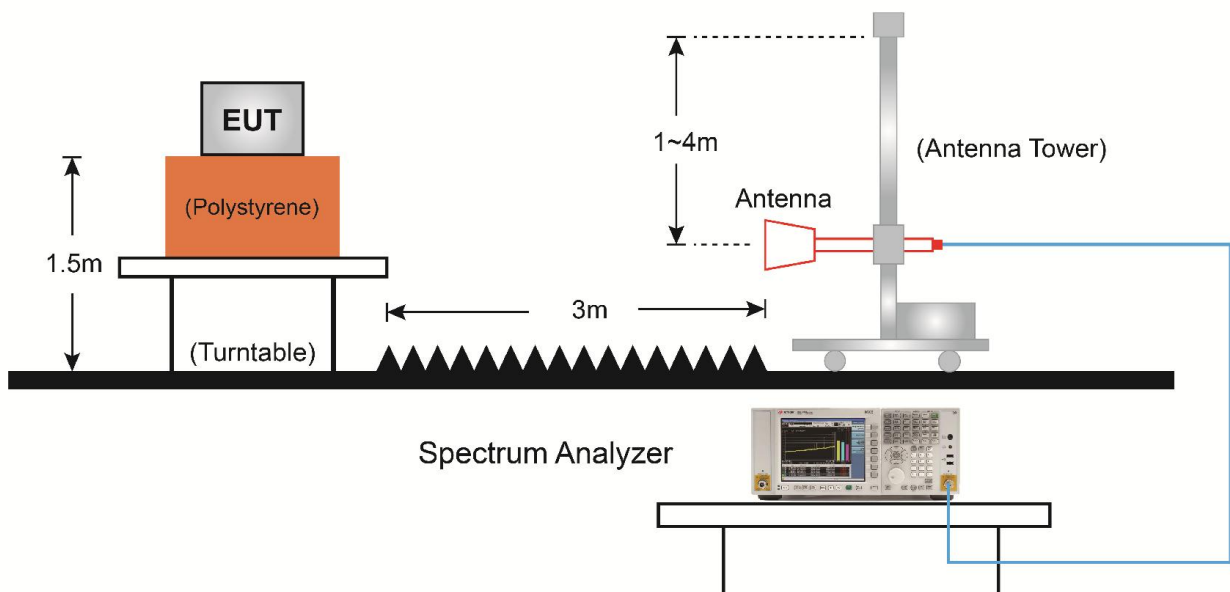

7.4.5. Test Result

Site: AC2	Time: 2019/05/14 - 05:07
Limit: Limit: FCC_Part15.209_RSE(3m)	Engineer: Dandy Li
Probe: BBHA9120D_1-18GHz	Polarity: Horizontal
EUT: W-LAN + Bluetooth Module	Power: DC 3.3V
Test Mode: Transmit by DH5 at channel 2402MHz	

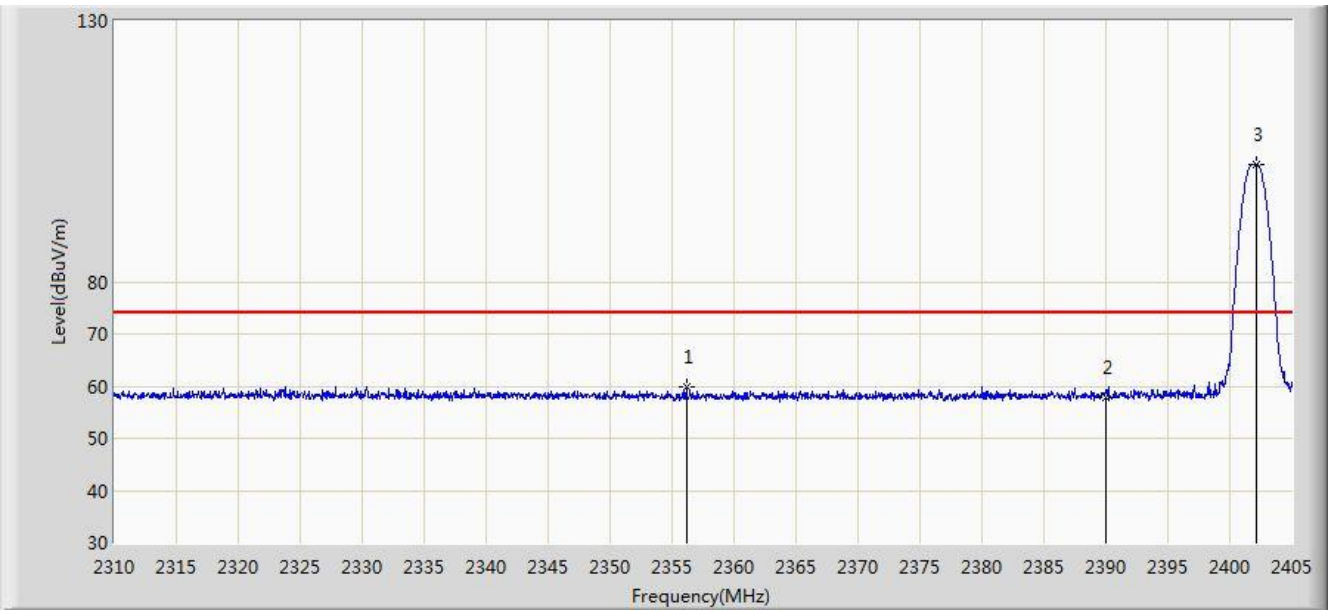

No	Flag	Mark	Frequency (MHz)	Measure Level (dBuV/m)	Reading Level (dBuV)	Over Limit (dB)	Limit (dBuV/m)	Factor (dB)	Type
1			2356.170	59.746	28.262	-14.254	74.000	31.484	PK
2			2390.000	57.775	26.326	-16.225	74.000	31.449	PK
3		*	2402.102	102.607	71.186	N/A	N/A	31.421	PK

Note: Measure Level (dB μ V/m) = Reading Level (dB μ V) + Factor (dB)

Factor (dB) = Cable Loss (dB) + Antenna Factor (dB/m)

Site: AC2	Time: 2019/05/14 - 05:11
Limit: Limit: FCC_Part15.209_RSE(3m)	Engineer: Dandy Li
Probe: BBHA9120D_1-18GHz	Polarity: Horizontal
EUT: W-LAN + Bluetooth Module	Power: DC 3.3V
Test Mode: Transmit by DH5 at channel 2402MHz	

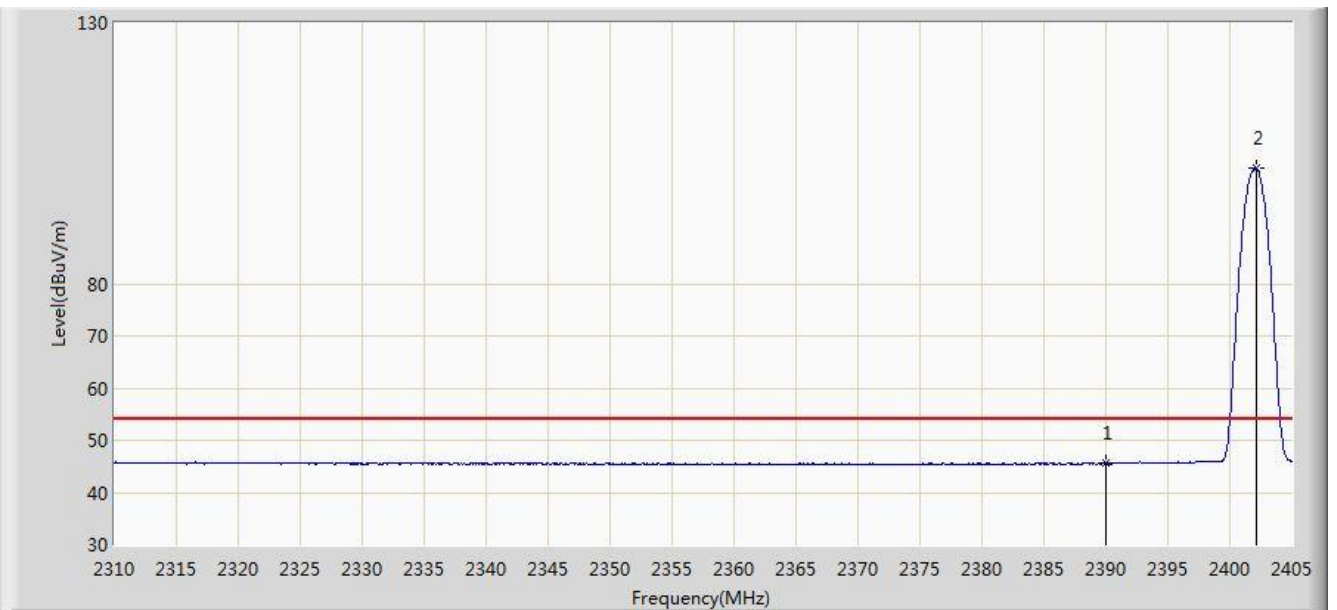

No	Flag	Mark	Frequency (MHz)	Measure Level (dBuV/m)	Reading Level (dBuV)	Over Limit (dB)	Limit (dBuV/m)	Factor (dB)	Type
1			2390.000	45.570	14.121	-8.430	54.000	31.449	AV
2		*	2402.150	102.067	70.646	N/A	N/A	31.421	AV

Note: Measure Level (dB μ V/m) = Reading Level (dB μ V) + Factor (dB)

Factor (dB) = Cable Loss (dB) + Antenna Factor (dB/m)

Site: AC2	Time: 2019/05/14 - 05:12
Limit: Limit: FCC_Part15.209_RSE(3m)	Engineer: Dandy Li
Probe: BBHA9120D_1-18GHz	Polarity: Vertical
EUT: W-LAN + Bluetooth Module	Power: DC 3.3V
Test Mode: Transmit by DH5 at channel 2402MHz	

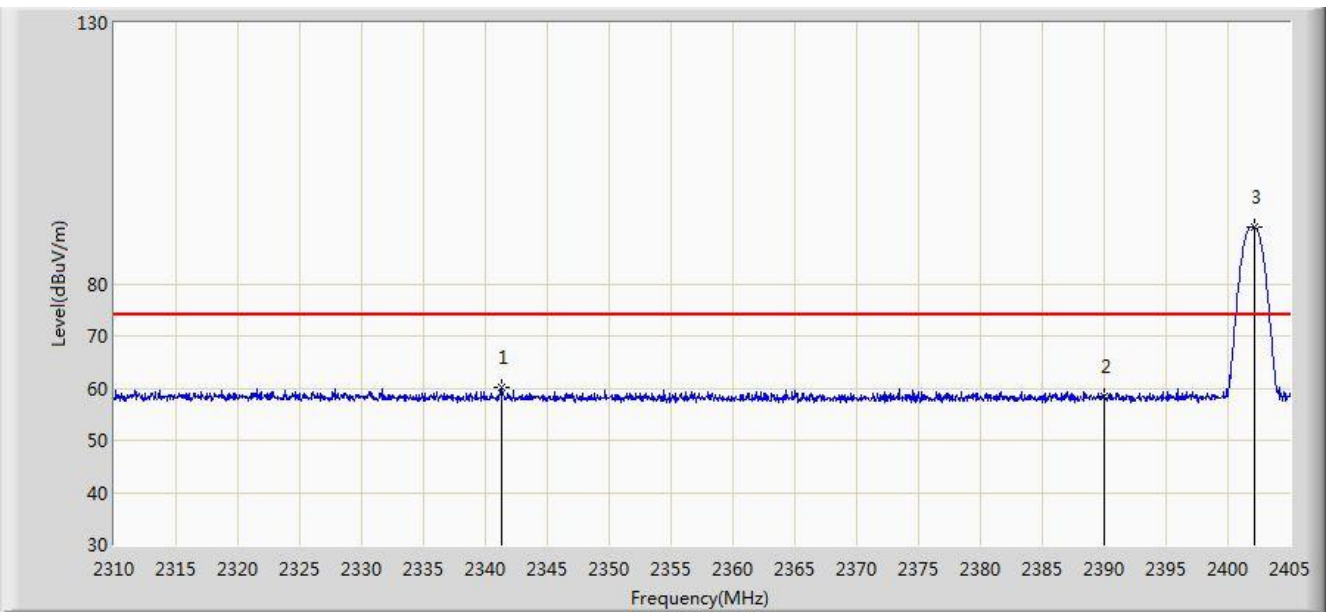

No	Flag	Mark	Frequency (MHz)	Measure Level (dBuV/m)	Reading Level (dBuV)	Over Limit (dB)	Limit (dBuV/m)	Factor (dB)	Type
1			2341.255	60.152	28.610	-13.848	74.000	31.541	PK
2			2390.000	58.275	26.826	-15.725	74.000	31.449	PK
3		*	2402.150	90.895	59.474	N/A	N/A	31.421	PK

Note: Measure Level (dB μ V/m) = Reading Level (dB μ V) + Factor (dB)

Factor (dB) = Cable Loss (dB) + Antenna Factor (dB/m)

Site: AC2	Time: 2019/05/14 - 05:14
Limit: Limit: FCC_Part15.209_RSE(3m)	Engineer: Dandy Li
Probe: BBHA9120D_1-18GHz	Polarity: Vertical
EUT: W-LAN + Bluetooth Module	Power: DC 3.3V
Test Mode: Transmit by DH5 at channel 2402MHz	

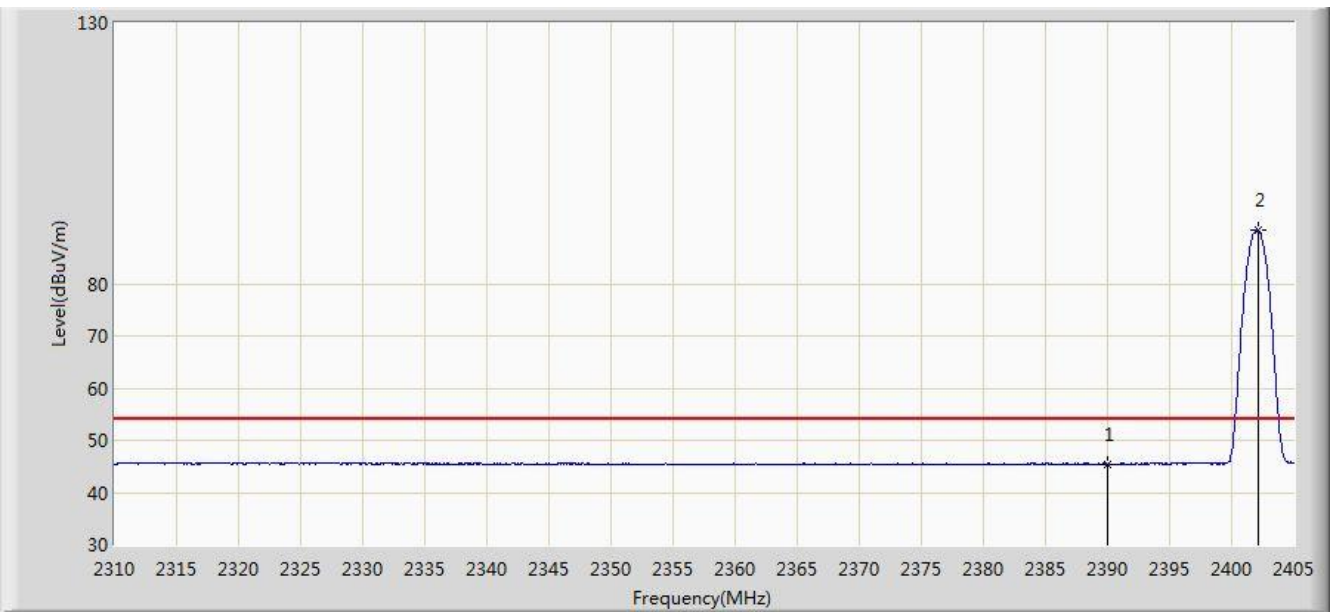

No	Flag	Mark	Frequency (MHz)	Measure Level (dBuV/m)	Reading Level (dBuV)	Over Limit (dB)	Limit (dBuV/m)	Factor (dB)	Type
1			2390.000	45.366	13.917	-8.634	54.000	31.449	AV
2		*	2402.150	90.252	58.831	N/A	N/A	31.421	AV

Note: Measure Level (dB μ V/m) = Reading Level (dB μ V) + Factor (dB)

Factor (dB) = Cable Loss (dB) + Antenna Factor (dB/m)

Site: AC2	Time: 2019/05/14 - 05:15
Limit: Limit: FCC_Part15.209_RSE(3m)	Engineer: Dandy Li
Probe: BBHA9120D_1-18GHz	Polarity: Horizontal
EUT: W-LAN + Bluetooth Module	Power: DC 3.3V
Test Mode: Transmit by DH5 at channel 2480MHz	

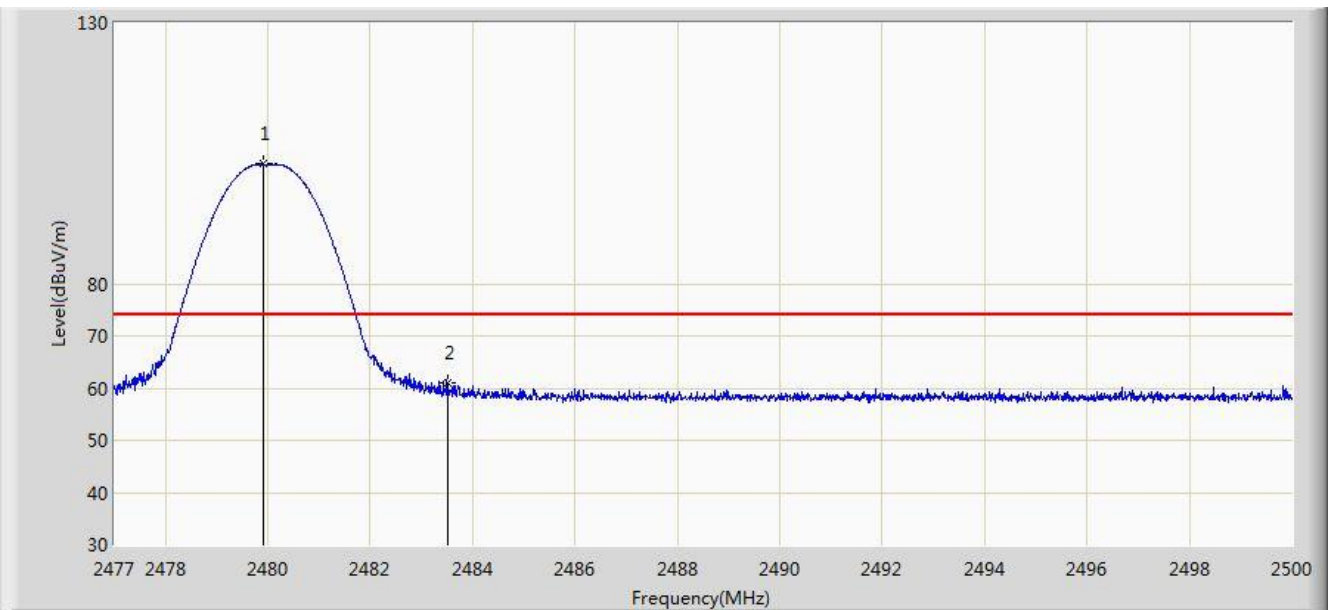

No	Flag	Mark	Frequency (MHz)	Measure Level (dBuV/m)	Reading Level (dBuV)	Over Limit (dB)	Limit (dBuV/m)	Factor (dB)	Type
1		*	2479.898	102.914	71.523	N/A	N/A	31.390	PK
2			2483.500	61.012	29.609	-12.988	74.000	31.403	PK

Note: Measure Level (dB μ V/m) = Reading Level (dB μ V) + Factor (dB)

Factor (dB) = Cable Loss (dB) + Antenna Factor (dB/m)

Site: AC2	Time: 2019/05/14 - 05:18
Limit: Limit: FCC_Part15.209_RSE(3m)	Engineer: Dandy Li
Probe: BBHA9120D_1-18GHz	Polarity: Horizontal
EUT: W-LAN + Bluetooth Module	Power: DC 3.3V
Test Mode: Transmit by DH5 at channel 2480MHz	

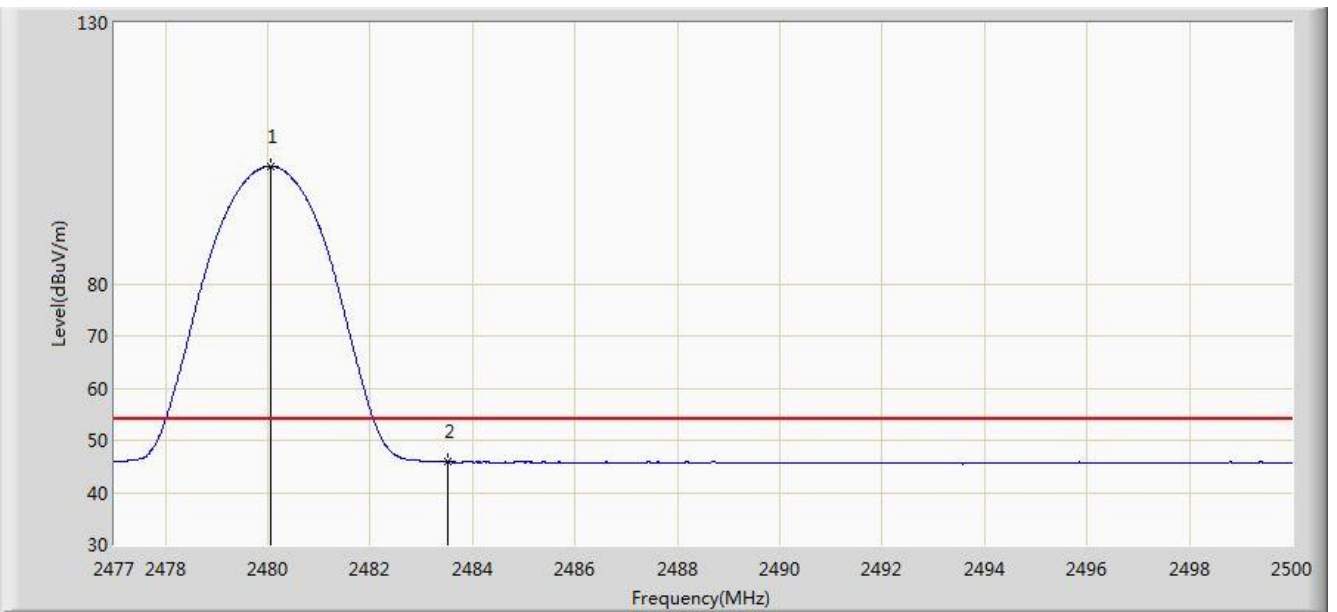

No	Flag	Mark	Frequency (MHz)	Measure Level (dBuV/m)	Reading Level (dBuV)	Over Limit (dB)	Limit (dBuV/m)	Factor (dB)	Type
1		*	2480.048	102.466	71.075	N/A	N/A	31.391	AV
2			2483.500	45.887	14.484	-8.113	54.000	31.403	AV

Note: Measure Level (dB μ V/m) = Reading Level (dB μ V) + Factor (dB)

Factor (dB) = Cable Loss (dB) + Antenna Factor (dB/m)

Site: AC2	Time: 2019/05/14 - 05:18
Limit: Limit: FCC_Part15.209_RSE(3m)	Engineer: Dandy Li
Probe: BBHA9120D_1-18GHz	Polarity: Vertical
EUT: W-LAN + Bluetooth Module	Power: DC 3.3V
Test Mode: Transmit by DH5 at channel 2480MHz	

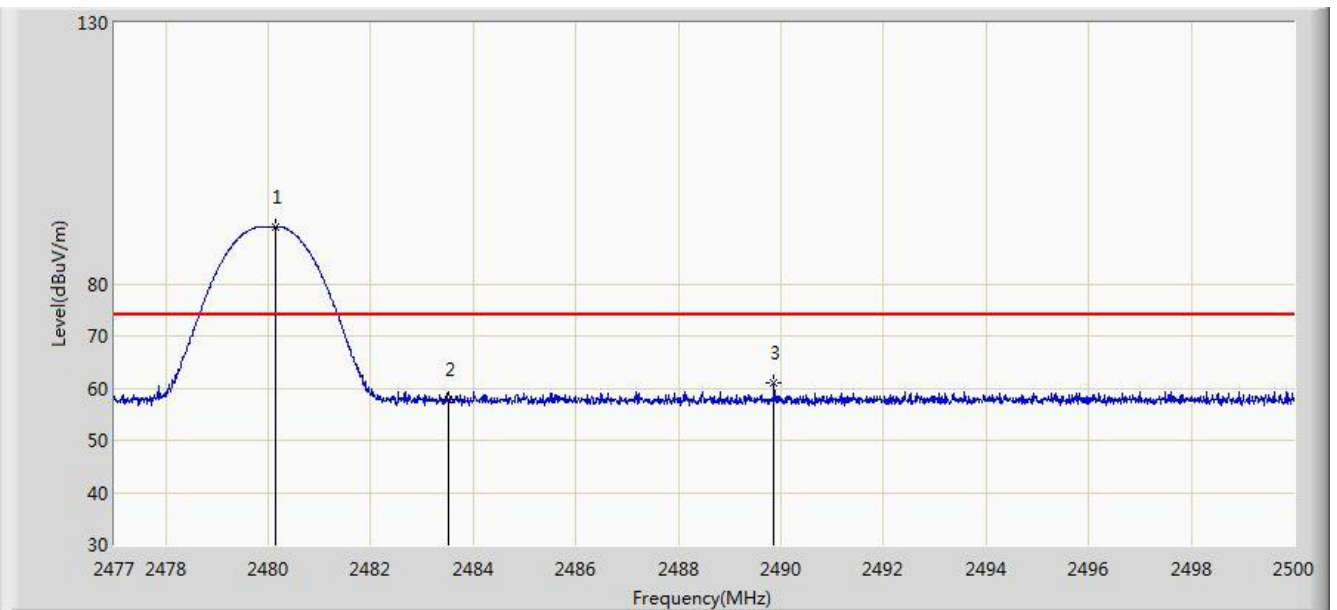

No	Flag	Mark	Frequency (MHz)	Measure Level (dBuV/m)	Reading Level (dBuV)	Over Limit (dB)	Limit (dBuV/m)	Factor (dB)	Type
1		*	2480.128	91.012	59.621	N/A	N/A	31.392	PK
2			2483.500	57.713	26.310	-16.287	74.000	31.403	PK
3			2489.857	60.958	29.534	-13.042	74.000	31.424	PK

Note: Measure Level (dB μ V/m) = Reading Level (dB μ V) + Factor (dB)

Factor (dB) = Cable Loss (dB) + Antenna Factor (dB/m)

Site: AC2	Time: 2019/05/14 - 05:19
Limit: Limit: FCC_Part15.209_RSE(3m)	Engineer: Dandy Li
Probe: BBHA9120D_1-18GHz	Polarity: Vertical
EUT: W-LAN + Bluetooth Module	Power: DC 3.3V
Test Mode: Transmit by DH5 at channel 2480MHz	

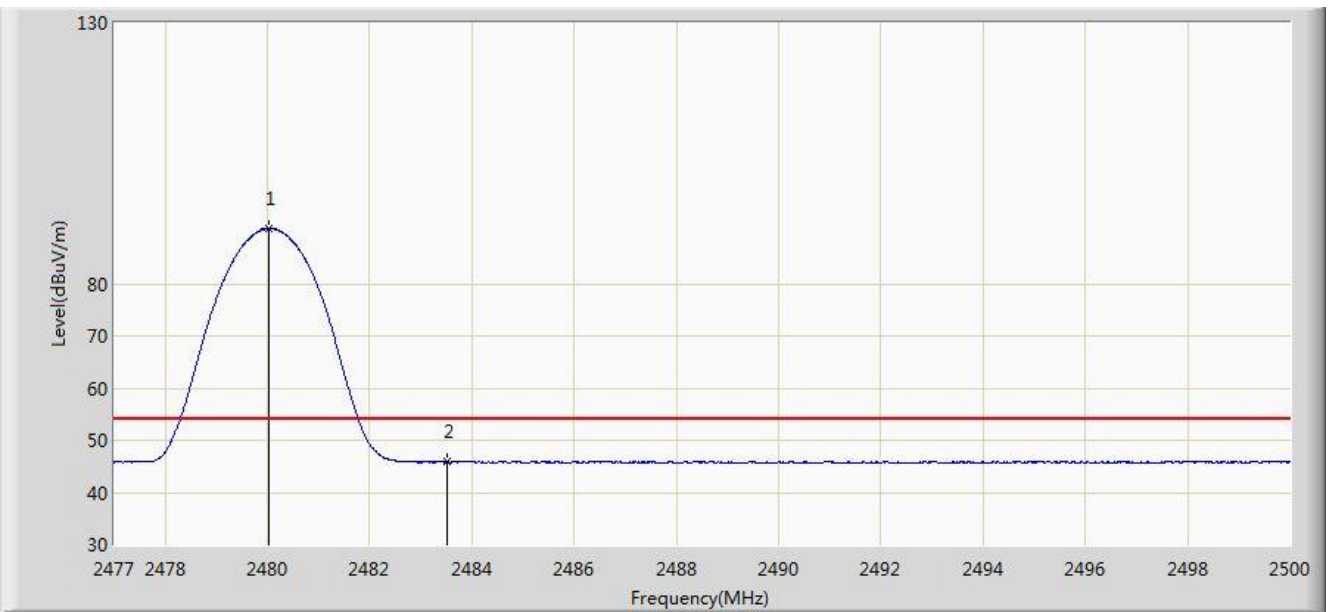

No	Flag	Mark	Frequency (MHz)	Measure Level (dBuV/m)	Reading Level (dBuV)	Over Limit (dB)	Limit (dBuV/m)	Factor (dB)	Type
1		*	2480.036	90.518	59.127	N/A	N/A	31.391	AV
2			2483.500	45.800	14.397	-8.200	54.000	31.403	AV

Note: Measure Level (dB μ V/m) = Reading Level (dB μ V) + Factor (dB)

Factor (dB) = Cable Loss (dB) + Antenna Factor (dB/m)

Site: AC2	Time: 2019/05/14 - 05:22
Limit: Limit: FCC_Part15.209_RSE(3m)	Engineer: Dandy Li
Probe: BBHA9120D_1-18GHz	Polarity: Horizontal
EUT: W-LAN + Bluetooth Module	Power: DC 3.3V
Test Mode: Transmit by 2DH5 at channel 2402MHz	

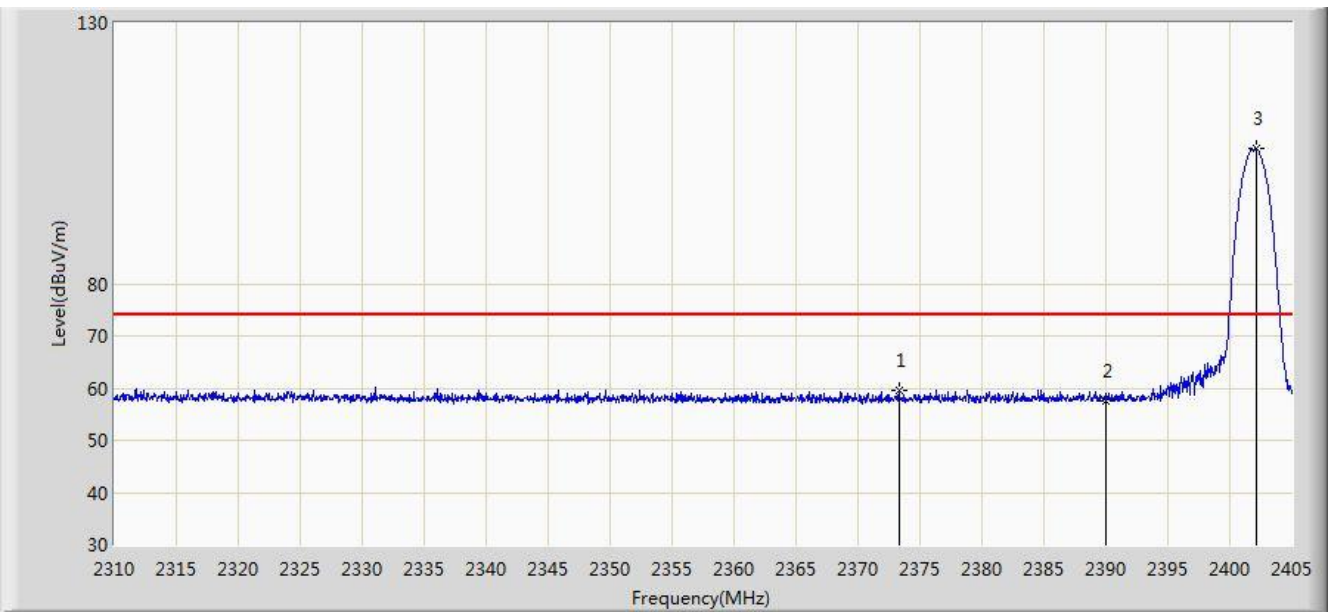

No	Flag	Mark	Frequency (MHz)	Measure Level (dBuV/m)	Reading Level (dBuV)	Over Limit (dB)	Limit (dBuV/m)	Factor (dB)	Type
1			2373.317	59.700	28.248	-14.300	74.000	31.452	PK
2			2390.000	57.492	26.043	-16.508	74.000	31.449	PK
3		*	2402.102	105.859	74.438	N/A	N/A	31.421	PK

Note: Measure Level (dB μ V/m) = Reading Level (dB μ V) + Factor (dB)

Factor (dB) = Cable Loss (dB) + Antenna Factor (dB/m)

Site: AC2	Time: 2019/05/14 - 05:24
Limit: Limit: FCC_Part15.209_RSE(3m)	Engineer: Dandy Li
Probe: BBHA9120D_1-18GHz	Polarity: Horizontal
EUT: W-LAN + Bluetooth Module	Power: DC 3.3V
Test Mode: Transmit by 2DH5 at channel 2402MHz	

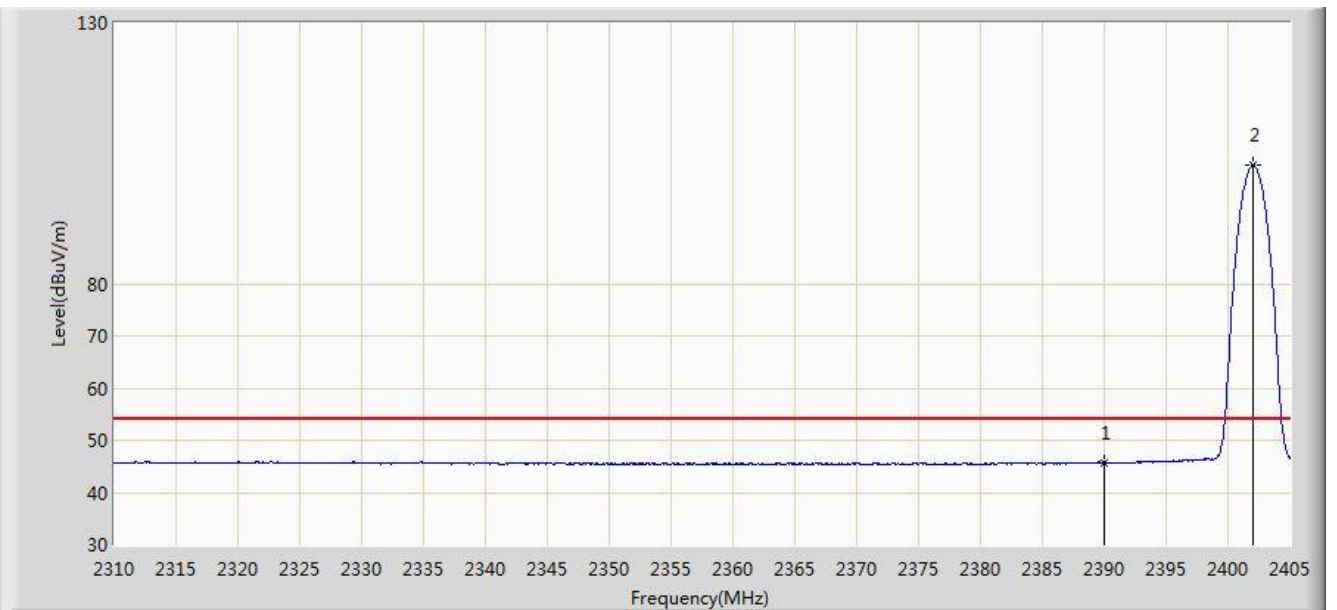

No	Flag	Mark	Frequency (MHz)	Measure Level (dBuV/m)	Reading Level (dBuV)	Over Limit (dB)	Limit (dBuV/m)	Factor (dB)	Type
1			2390.000	45.791	14.342	-8.209	54.000	31.449	AV
2		*	2402.055	102.648	71.227	N/A	N/A	31.421	AV

Note: Measure Level (dB μ V/m) = Reading Level (dB μ V) + Factor (dB)

Factor (dB) = Cable Loss (dB) + Antenna Factor (dB/m)

Site: AC2	Time: 2019/05/14 - 05:25
Limit: Limit: FCC_Part15.209_RSE(3m)	Engineer: Dandy Li
Probe: BBHA9120D_1-18GHz	Polarity: Vertical
EUT: W-LAN + Bluetooth Module	Power: DC 3.3V
Test Mode: Transmit by 2DH5 at channel 2402MHz	

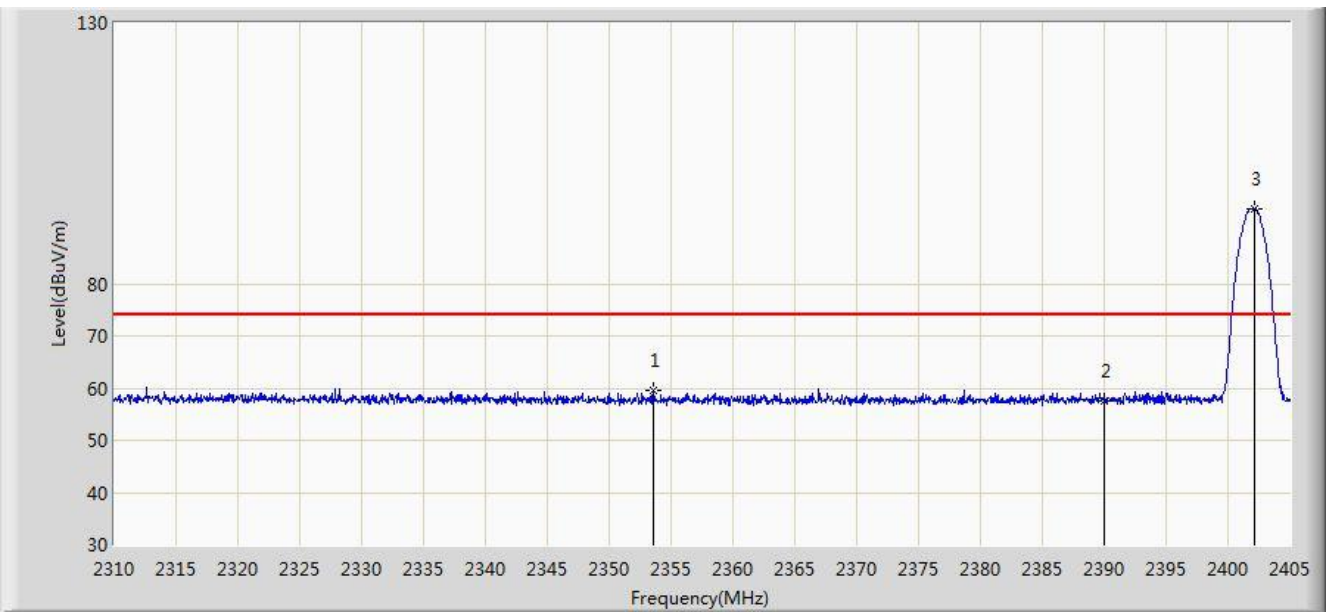

No	Flag	Mark	Frequency (MHz)	Measure Level (dBuV/m)	Reading Level (dBuV)	Over Limit (dB)	Limit (dBuV/m)	Factor (dB)	Type
1			2353.558	59.705	28.211	-14.295	74.000	31.494	PK
2			2390.000	57.604	26.155	-16.396	74.000	31.449	PK
3		*	2402.150	94.483	63.062	N/A	N/A	31.421	PK

Note: Measure Level (dB μ V/m) = Reading Level (dB μ V) + Factor (dB)

Factor (dB) = Cable Loss (dB) + Antenna Factor (dB/m)

Site: AC2	Time: 2019/05/14 - 05:26
Limit: Limit: FCC_Part15.209_RSE(3m)	Engineer: Dandy Li
Probe: BBHA9120D_1-18GHz	Polarity: Vertical
EUT: W-LAN + Bluetooth Module	Power: DC 3.3V
Test Mode: Transmit by 2DH5 at channel 2402MHz	

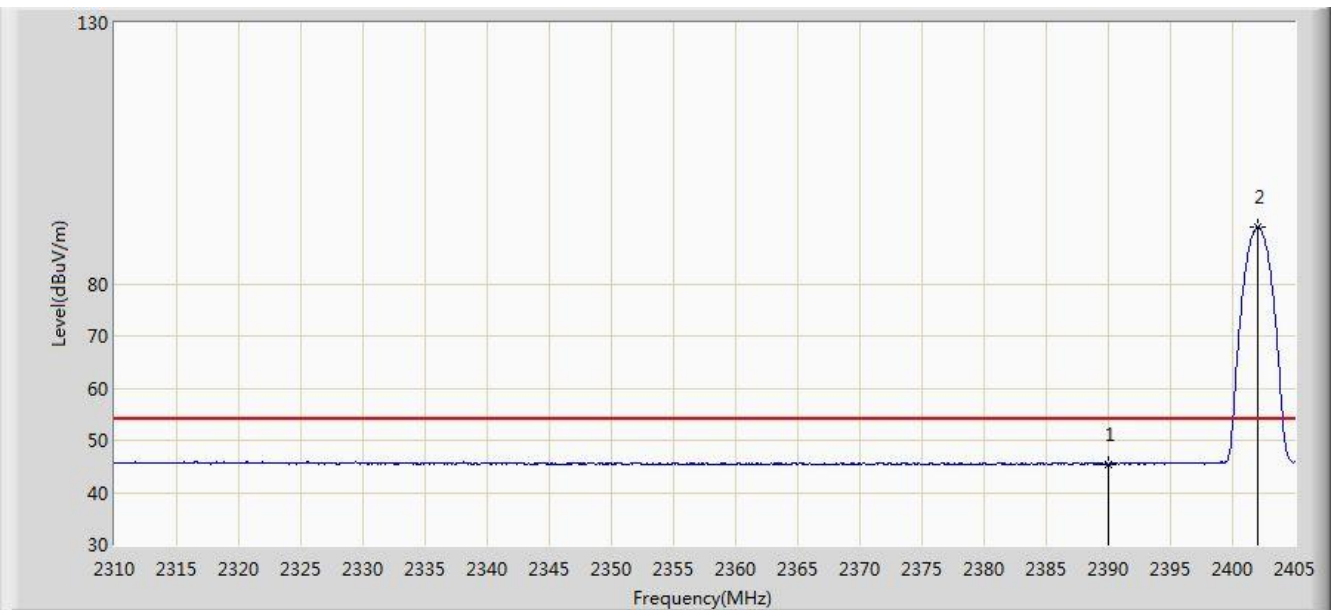

No	Flag	Mark	Frequency (MHz)	Measure Level (dBuV/m)	Reading Level (dBuV)	Over Limit (dB)	Limit (dBuV/m)	Factor (dB)	Type
1			2390.000	45.383	13.934	-8.617	54.000	31.449	AV
2		*	2402.055	90.841	59.420	N/A	N/A	31.421	AV

Note: Measure Level (dB μ V/m) = Reading Level (dB μ V) + Factor (dB)

Factor (dB) = Cable Loss (dB) + Antenna Factor (dB/m)

Site: AC2	Time: 2019/05/14 - 05:27
Limit: Limit: FCC_Part15.209_RSE(3m)	Engineer: Dandy Li
Probe: BBHA9120D_1-18GHz	Polarity: Horizontal
EUT: W-LAN + Bluetooth Module	Power: DC 3.3V
Test Mode: Transmit by 2DH5 at channel 2480MHz	

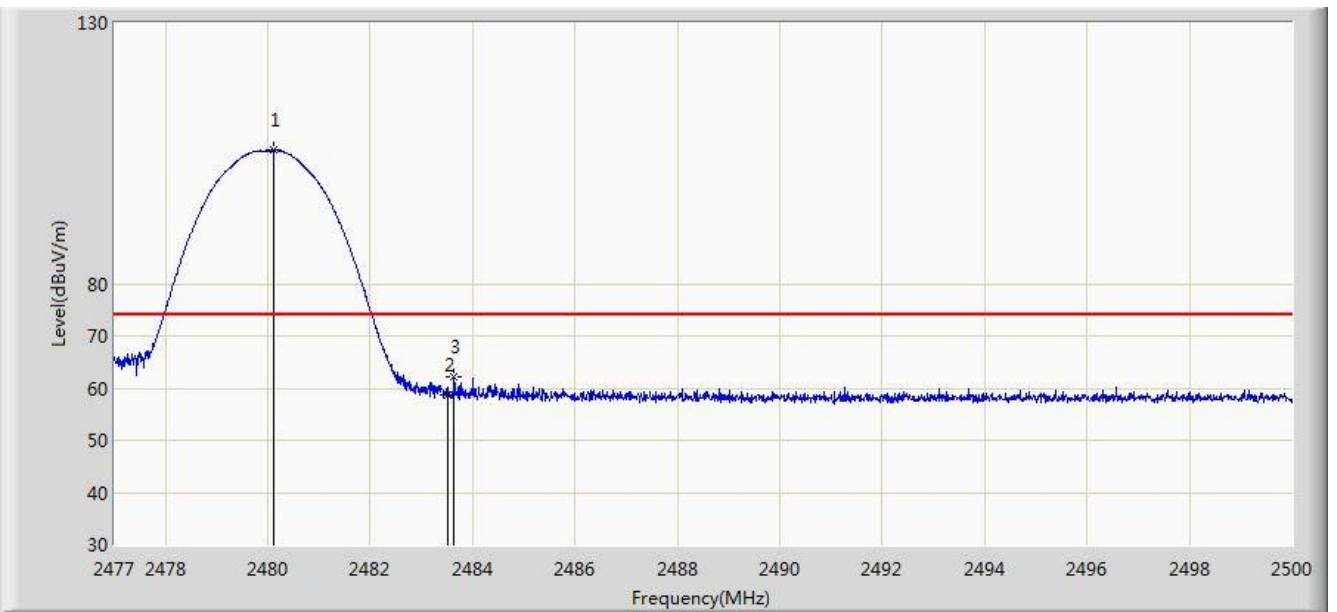

No	Flag	Mark	Frequency (MHz)	Measure Level (dBuV/m)	Reading Level (dBuV)	Over Limit (dB)	Limit (dBuV/m)	Factor (dB)	Type
1		*	2480.105	105.577	74.186	N/A	N/A	31.391	PK
2			2483.500	58.685	27.282	-15.315	74.000	31.403	PK
3			2483.635	62.231	30.828	-11.769	74.000	31.403	PK

Note: Measure Level (dB μ V/m) = Reading Level (dB μ V) + Factor (dB)

Factor (dB) = Cable Loss (dB) + Antenna Factor (dB/m)

Site: AC2	Time: 2019/05/14 - 05:28
Limit: Limit: FCC_Part15.209_RSE(3m)	Engineer: Dandy Li
Probe: BBHA9120D_1-18GHz	Polarity: Horizontal
EUT: W-LAN + Bluetooth Module	Power: DC 3.3V
Test Mode: Transmit by 2DH5 at channel 2480MHz	

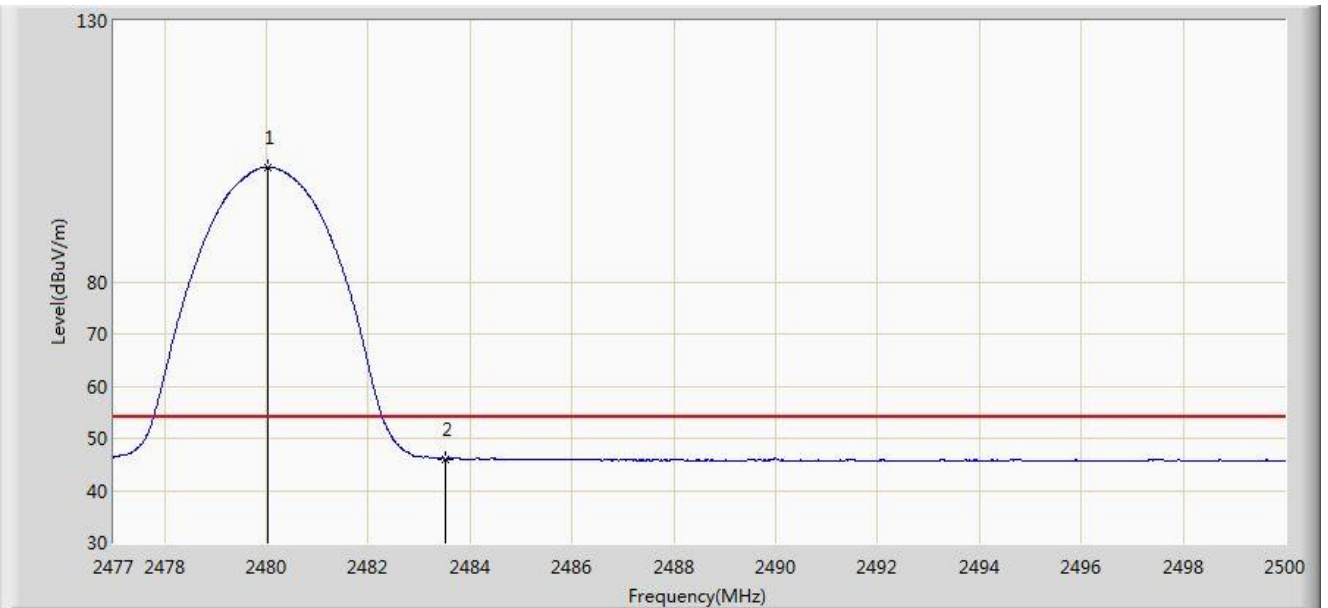

No	Flag	Mark	Frequency (MHz)	Measure Level (dBuV/m)	Reading Level (dBuV)	Over Limit (dB)	Limit (dBuV/m)	Factor (dB)	Type
1		*	2480.025	101.993	70.602	N/A	N/A	31.391	AV
2			2483.500	46.055	14.652	-7.945	54.000	31.403	AV

Note: Measure Level (dB μ V/m) = Reading Level (dB μ V) + Factor (dB)

Factor (dB) = Cable Loss (dB) + Antenna Factor (dB/m)

Site: AC2	Time: 2019/05/14 - 05:29
Limit: Limit: FCC_Part15.209_RSE(3m)	Engineer: Dandy Li
Probe: BBHA9120D_1-18GHz	Polarity: Vertical
EUT: W-LAN + Bluetooth Module	Power: DC 3.3V
Test Mode: Transmit by 2DH5 at channel 2480MHz	

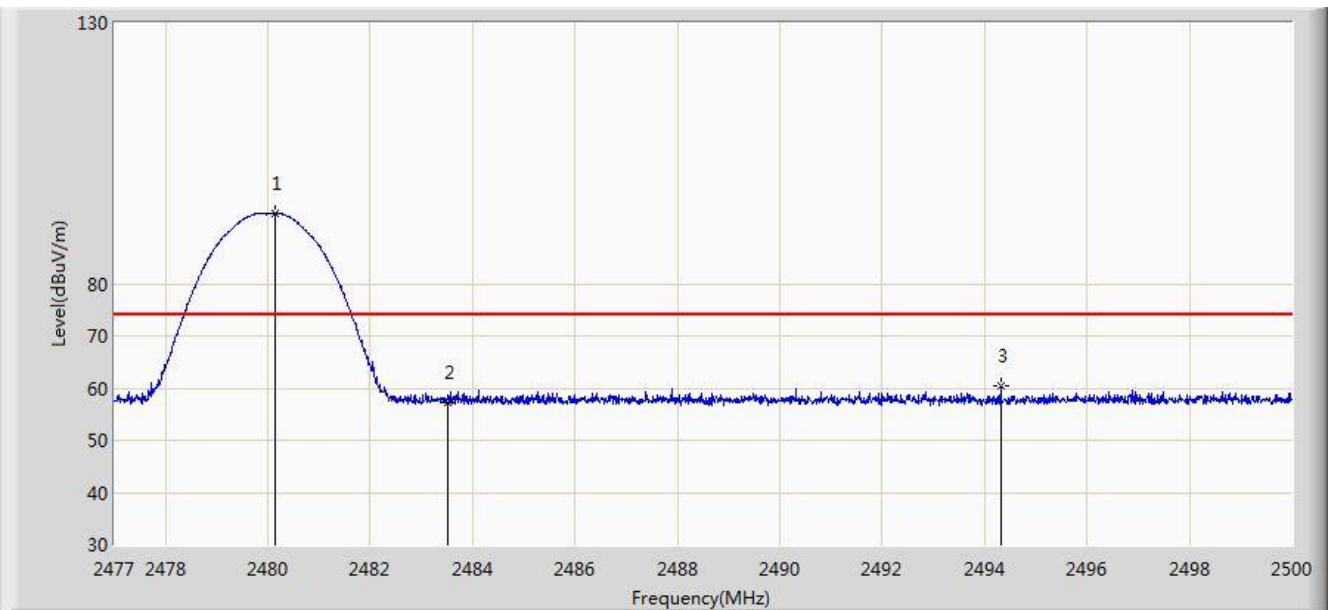

No	Flag	Mark	Frequency (MHz)	Measure Level (dBuV/m)	Reading Level (dBuV)	Over Limit (dB)	Limit (dBuV/m)	Factor (dB)	Type
1		*	2480.128	93.621	62.230	N/A	N/A	31.392	PK
2			2483.500	57.299	25.896	-16.701	74.000	31.403	PK
3			2494.319	60.298	28.858	-13.702	74.000	31.439	PK

Note: Measure Level (dB μ V/m) = Reading Level (dB μ V) + Factor (dB)

Factor (dB) = Cable Loss (dB) + Antenna Factor (dB/m)

Site: AC2	Time: 2019/05/14 - 05:30
Limit: Limit: FCC_Part15.209_RSE(3m)	Engineer: Dandy Li
Probe: BBHA9120D_1-18GHz	Polarity: Vertical
EUT: W-LAN + Bluetooth Module	Power: DC 3.3V
Test Mode: Transmit by 2DH5 at channel 2480MHz	

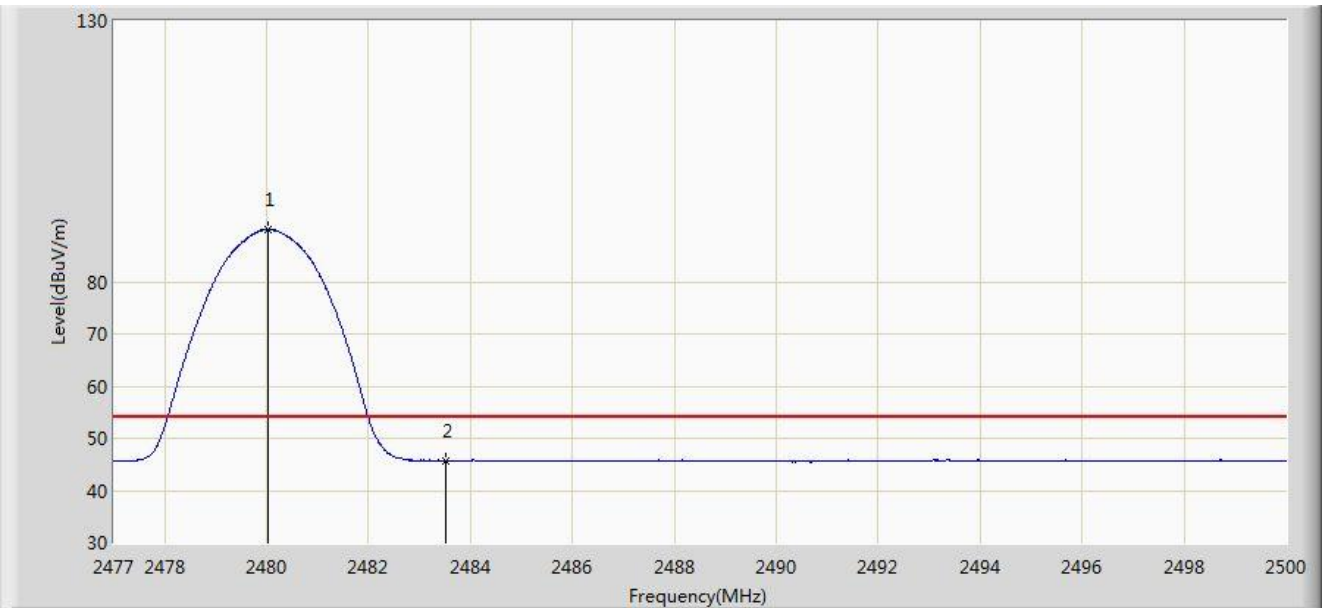

No	Flag	Mark	Frequency (MHz)	Measure Level (dBuV/m)	Reading Level (dBuV)	Over Limit (dB)	Limit (dBuV/m)	Factor (dB)	Type
1		*	2480.013	90.019	58.628	N/A	N/A	31.391	AV
2			2483.500	45.657	14.254	-8.343	54.000	31.403	AV

Note: Measure Level (dB μ V/m) = Reading Level (dB μ V) + Factor (dB)

Factor (dB) = Cable Loss (dB) + Antenna Factor (dB/m)

Site: AC2	Time: 2019/05/14 - 05:30
Limit: Limit: FCC_Part15.209_RSE(3m)	Engineer: Dandy Li
Probe: BBHA9120D_1-18GHz	Polarity: Horizontal
EUT: W-LAN + Bluetooth Module	Power: DC 3.3V
Test Mode: Transmit by 3DH5 at channel 2402MHz	

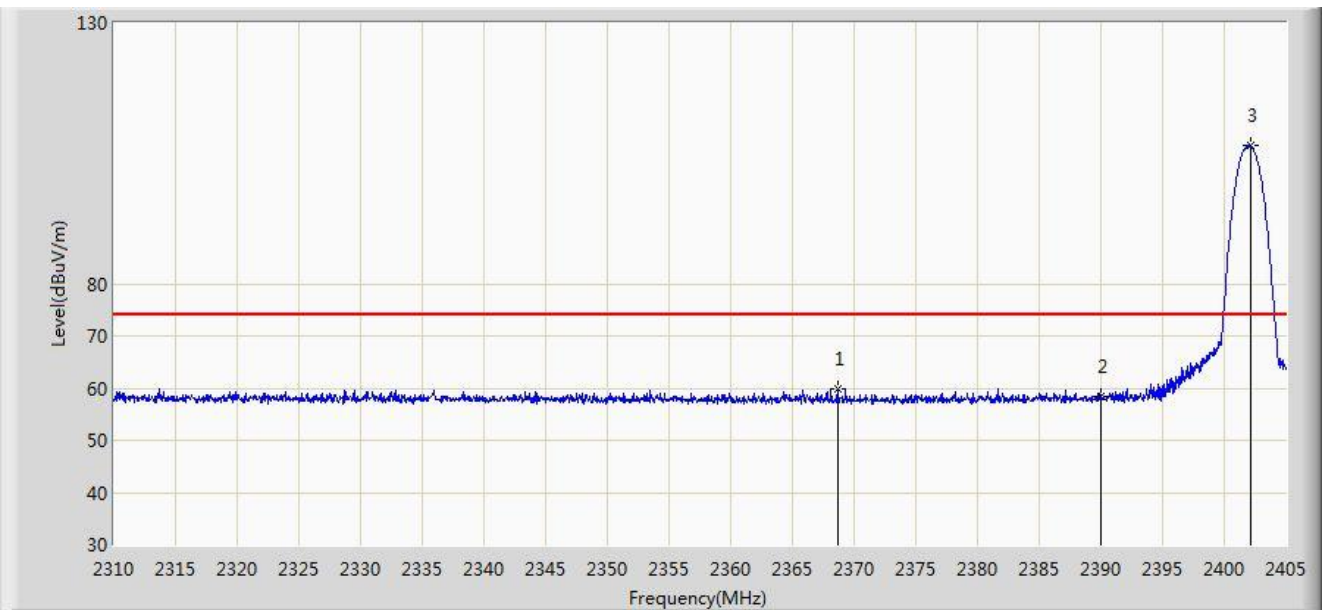

No	Flag	Mark	Frequency (MHz)	Measure Level (dBuV/m)	Reading Level (dBuV)	Over Limit (dB)	Limit (dBuV/m)	Factor (dB)	Type
1			2368.663	59.740	28.280	-14.260	74.000	31.460	PK
2			2390.000	58.425	26.976	-15.575	74.000	31.449	PK
3		*	2402.102	106.462	75.041	N/A	N/A	31.421	PK

Note: Measure Level (dB μ V/m) = Reading Level (dB μ V) + Factor (dB)

Factor (dB) = Cable Loss (dB) + Antenna Factor (dB/m)

Site: AC2	Time: 2019/05/14 - 05:32
Limit: Limit: FCC_Part15.209_RSE(3m)	Engineer: Dandy Li
Probe: BBHA9120D_1-18GHz	Polarity: Horizontal
EUT: W-LAN + Bluetooth Module	Power: DC 3.3V
Test Mode: Transmit by 3DH5 at channel 2402MHz	

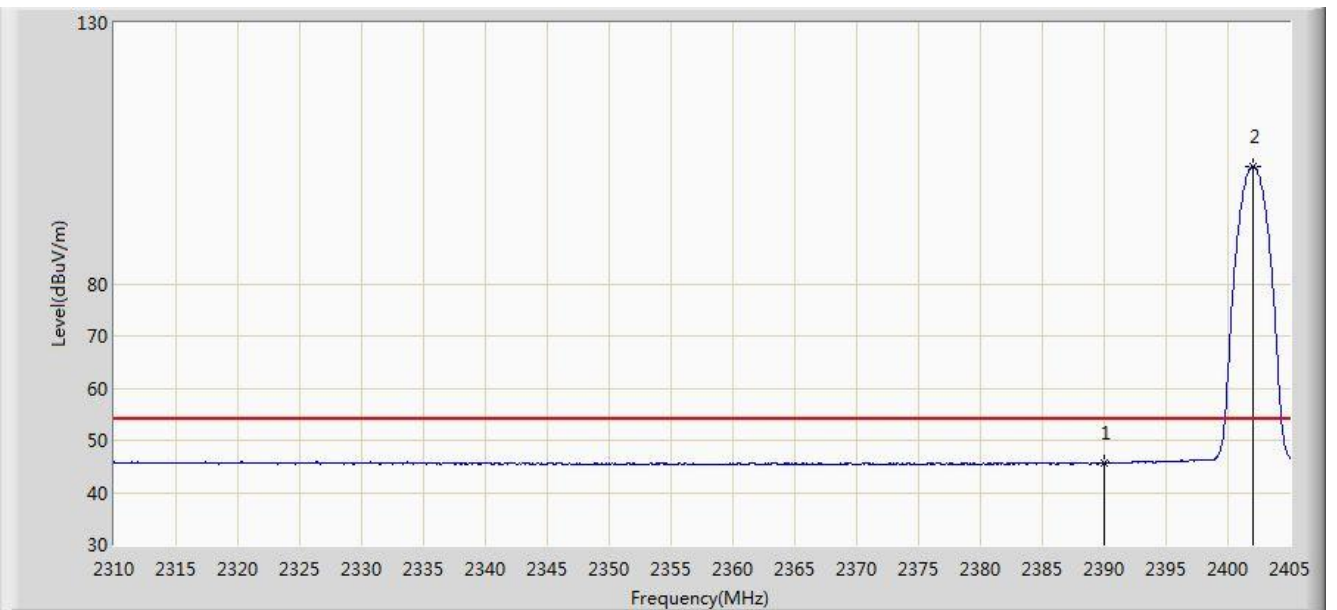

No	Flag	Mark	Frequency (MHz)	Measure Level (dBuV/m)	Reading Level (dBuV)	Over Limit (dB)	Limit (dBuV/m)	Factor (dB)	Type
1			2390.000	45.643	14.194	-8.357	54.000	31.449	AV
2		*	2402.008	102.546	71.124	N/A	N/A	31.422	AV

Note: Measure Level (dB μ V/m) = Reading Level (dB μ V) + Factor (dB)

Factor (dB) = Cable Loss (dB) + Antenna Factor (dB/m)

Site: AC2	Time: 2019/05/14 - 05:33
Limit: Limit: FCC_Part15.209_RSE(3m)	Engineer: Dandy Li
Probe: BBHA9120D_1-18GHz	Polarity: Vertical
EUT: W-LAN + Bluetooth Module	Power: DC 3.3V
Test Mode: Transmit by 3DH5 at channel 2402MHz	

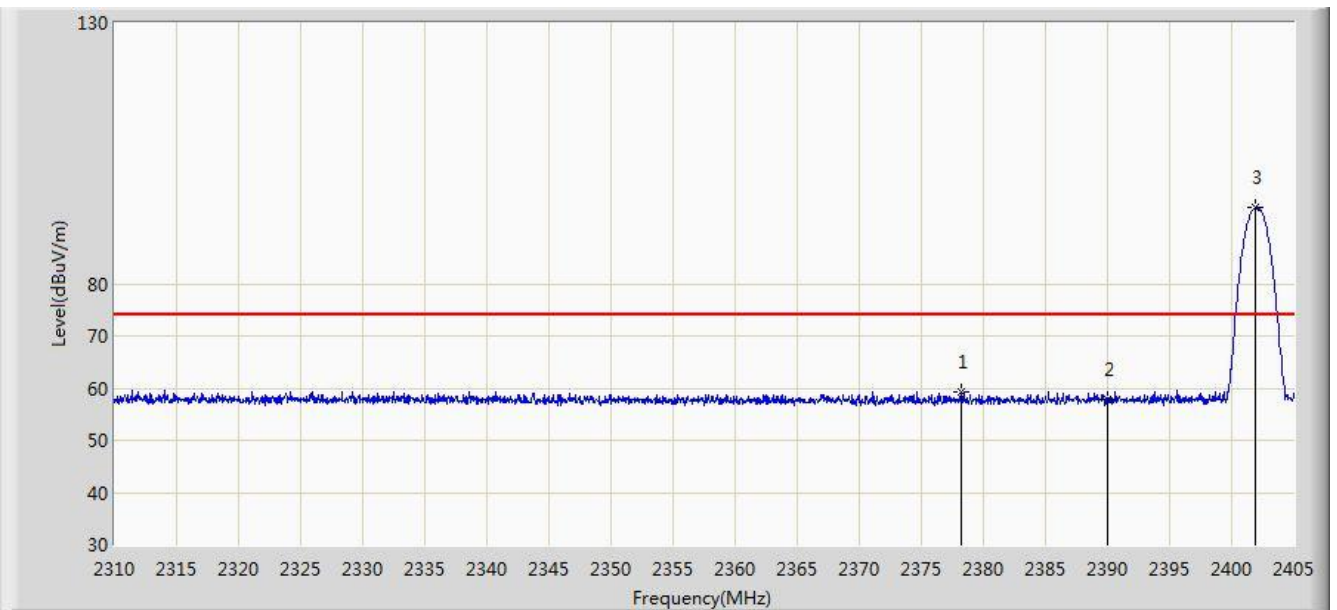

No	Flag	Mark	Frequency (MHz)	Measure Level (dBuV/m)	Reading Level (dBuV)	Over Limit (dB)	Limit (dBuV/m)	Factor (dB)	Type
1			2378.258	59.158	27.711	-14.842	74.000	31.446	PK
2			2390.000	57.950	26.501	-16.050	74.000	31.449	PK
3		*	2401.960	94.683	63.261	N/A	N/A	31.422	PK

Note: Measure Level (dB μ V/m) = Reading Level (dB μ V) + Factor (dB)

Factor (dB) = Cable Loss (dB) + Antenna Factor (dB/m)

Site: AC2	Time: 2019/05/14 - 05:34
Limit: Limit: FCC_Part15.209_RSE(3m)	Engineer: Dandy Li
Probe: BBHA9120D_1-18GHz	Polarity: Vertical
EUT: W-LAN + Bluetooth Module	Power: DC 3.3V
Test Mode: Transmit by 3DH5 at channel 2402MHz	

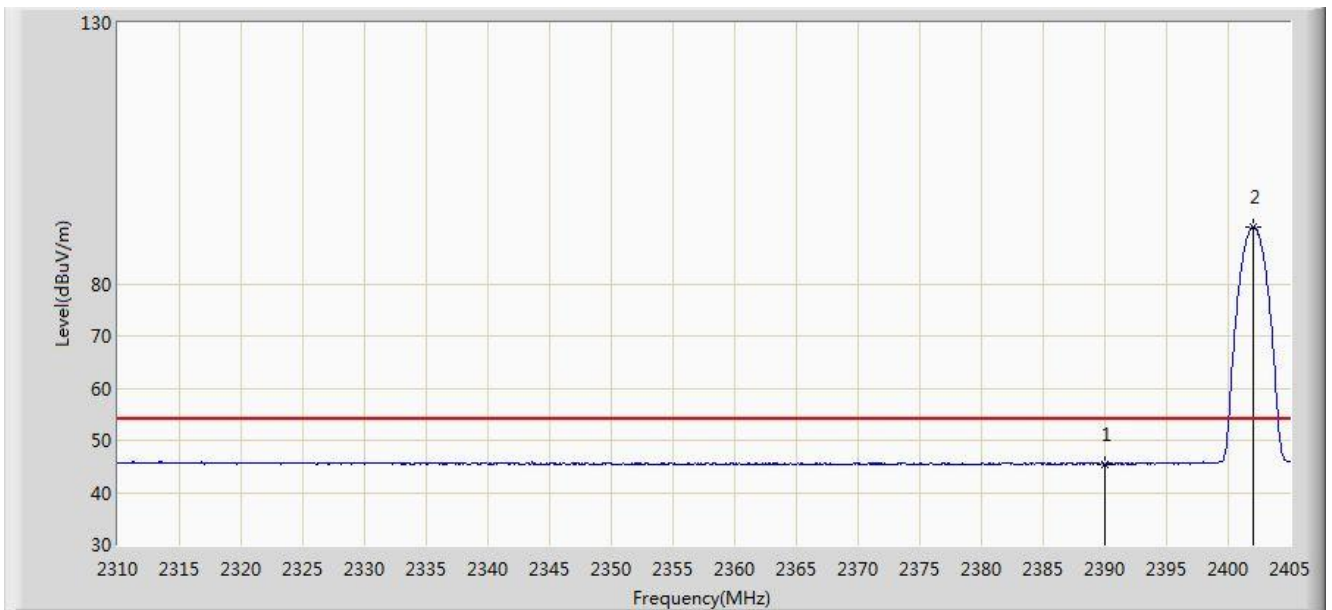

No	Flag	Mark	Frequency (MHz)	Measure Level (dBuV/m)	Reading Level (dBuV)	Over Limit (dB)	Limit (dBuV/m)	Factor (dB)	Type
1			2390.000	45.393	13.944	-8.607	54.000	31.449	AV
2		*	2402.055	90.848	59.427	N/A	N/A	31.421	AV

Note: Measure Level (dB μ V/m) = Reading Level (dB μ V) + Factor (dB)

Factor (dB) = Cable Loss (dB) + Antenna Factor (dB/m)

Site: AC2	Time: 2019/05/14 - 05:34
Limit: Limit: FCC_Part15.209_RSE(3m)	Engineer: Dandy Li
Probe: BBHA9120D_1-18GHz	Polarity: Horizontal
EUT: W-LAN + Bluetooth Module	Power: DC 3.3V
Test Mode: Transmit by 3DH5 at channel 2480MHz	

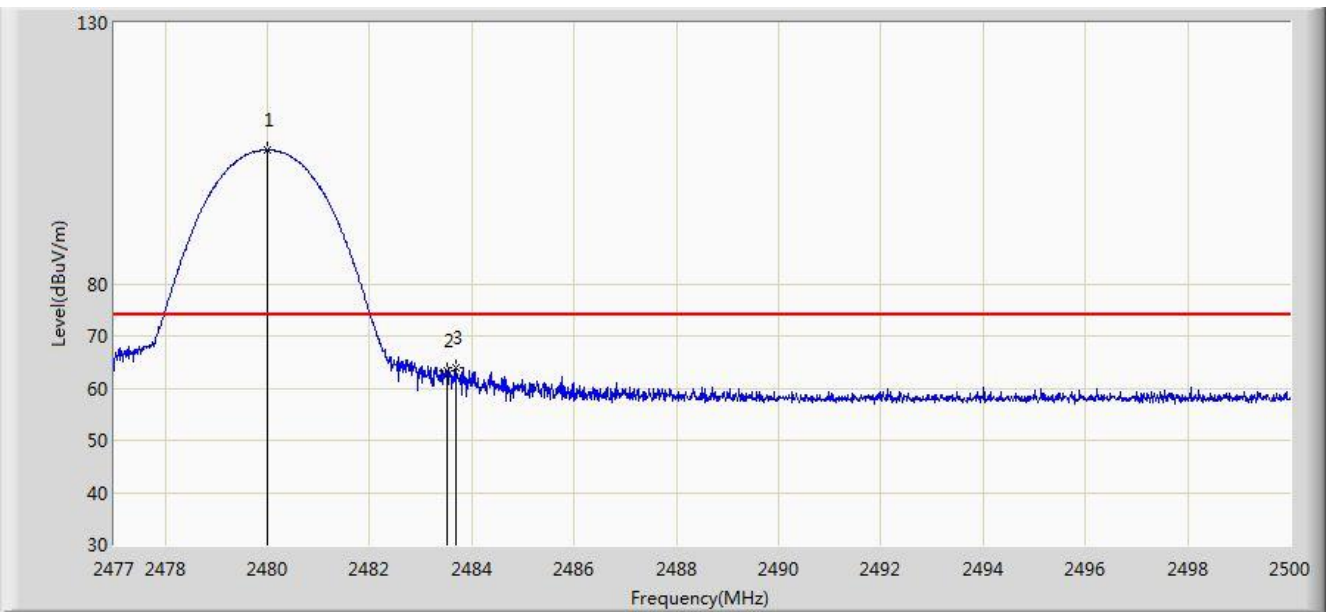

No	Flag	Mark	Frequency (MHz)	Measure Level (dBuV/m)	Reading Level (dBuV)	Over Limit (dB)	Limit (dBuV/m)	Factor (dB)	Type
1		*	2480.002	105.787	74.396	N/A	N/A	31.391	PK
2			2483.500	63.391	31.988	-10.609	74.000	31.403	PK
3			2483.693	63.890	32.487	-10.110	74.000	31.403	PK

Note: Measure Level (dB μ V/m) = Reading Level (dB μ V) + Factor (dB)

Factor (dB) = Cable Loss (dB) + Antenna Factor (dB/m)

Site: AC2	Time: 2019/05/14 - 05:36
Limit: Limit: FCC_Part15.209_RSE(3m)	Engineer: Dandy Li
Probe: BBHA9120D_1-18GHz	Polarity: Horizontal
EUT: W-LAN + Bluetooth Module	Power: DC 3.3V
Test Mode: Transmit by 3DH5 at channel 2480MHz	

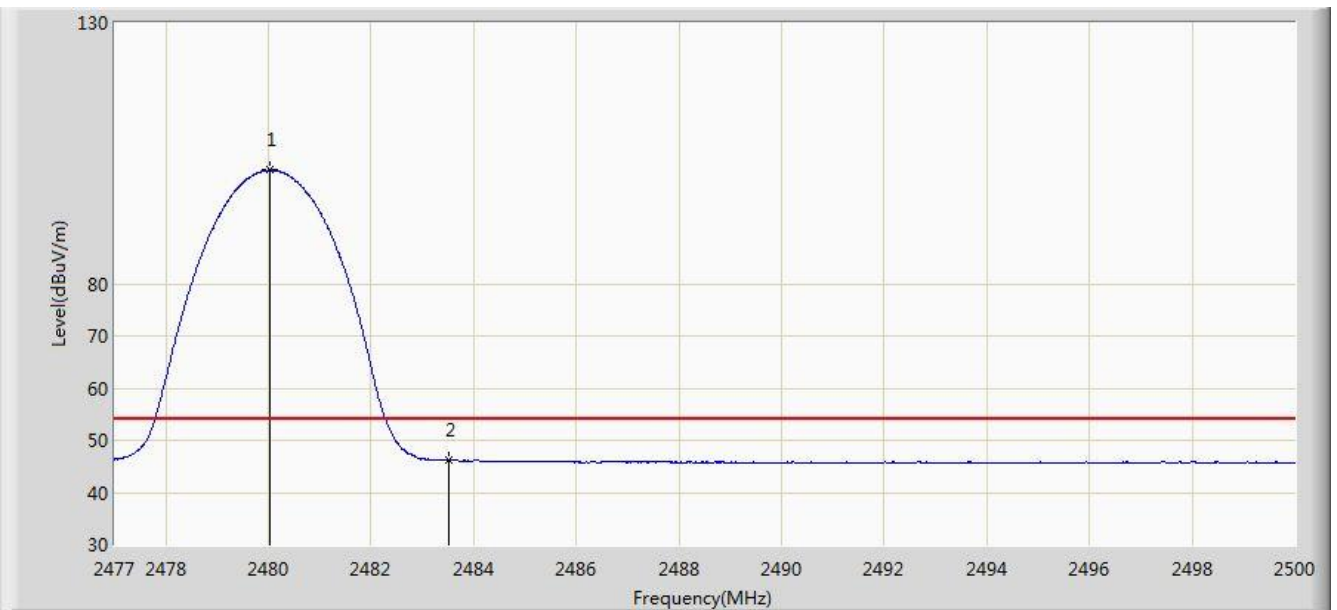

No	Flag	Mark	Frequency (MHz)	Measure Level (dBuV/m)	Reading Level (dBuV)	Over Limit (dB)	Limit (dBuV/m)	Factor (dB)	Type
1		*	2480.036	101.750	70.359	N/A	N/A	31.391	AV
2			2483.500	46.168	14.765	-7.832	54.000	31.403	AV

Note: Measure Level (dB μ V/m) = Reading Level (dB μ V) + Factor (dB)

Factor (dB) = Cable Loss (dB) + Antenna Factor (dB/m)

Site: AC2	Time: 2019/05/14 - 05:36
Limit: Limit: FCC_Part15.209_RSE(3m)	Engineer: Dandy Li
Probe: BBHA9120D_1-18GHz	Polarity: Vertical
EUT: W-LAN + Bluetooth Module	Power: DC 3.3V
Test Mode: Transmit by 3DH5 at channel 2480MHz	

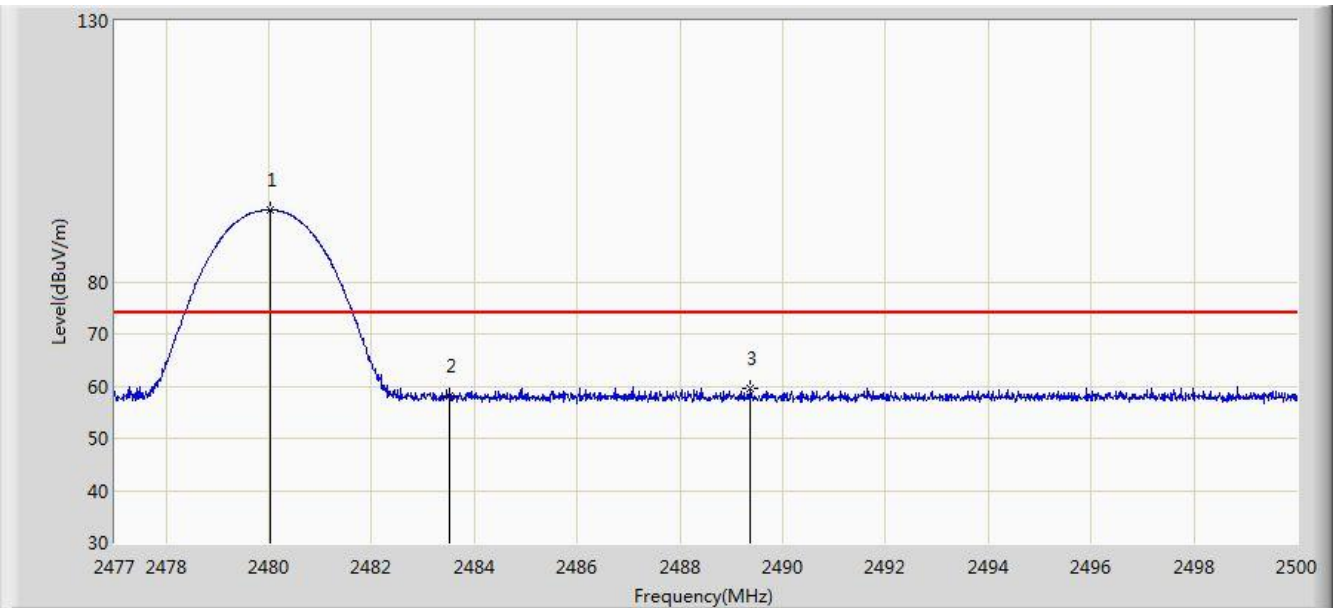

No	Flag	Mark	Frequency (MHz)	Measure Level (dBuV/m)	Reading Level (dBuV)	Over Limit (dB)	Limit (dBuV/m)	Factor (dB)	Type
1		*	2480.036	93.890	62.499	N/A	N/A	31.391	PK
2			2483.500	58.044	26.641	-15.956	74.000	31.403	PK
3			2489.351	59.698	28.275	-14.302	74.000	31.422	PK

Note: Measure Level (dB μ V/m) = Reading Level (dB μ V) + Factor (dB)

Factor (dB) = Cable Loss (dB) + Antenna Factor (dB/m)

Site: AC2	Time: 2019/05/14 - 05:37
Limit: Limit: FCC_Part15.209_RSE(3m)	Engineer: Dandy Li
Probe: BBHA9120D_1-18GHz	Polarity: Vertical
EUT: W-LAN + Bluetooth Module	Power: DC 3.3V
Test Mode: Transmit by 3DH5 at channel 2480MHz	

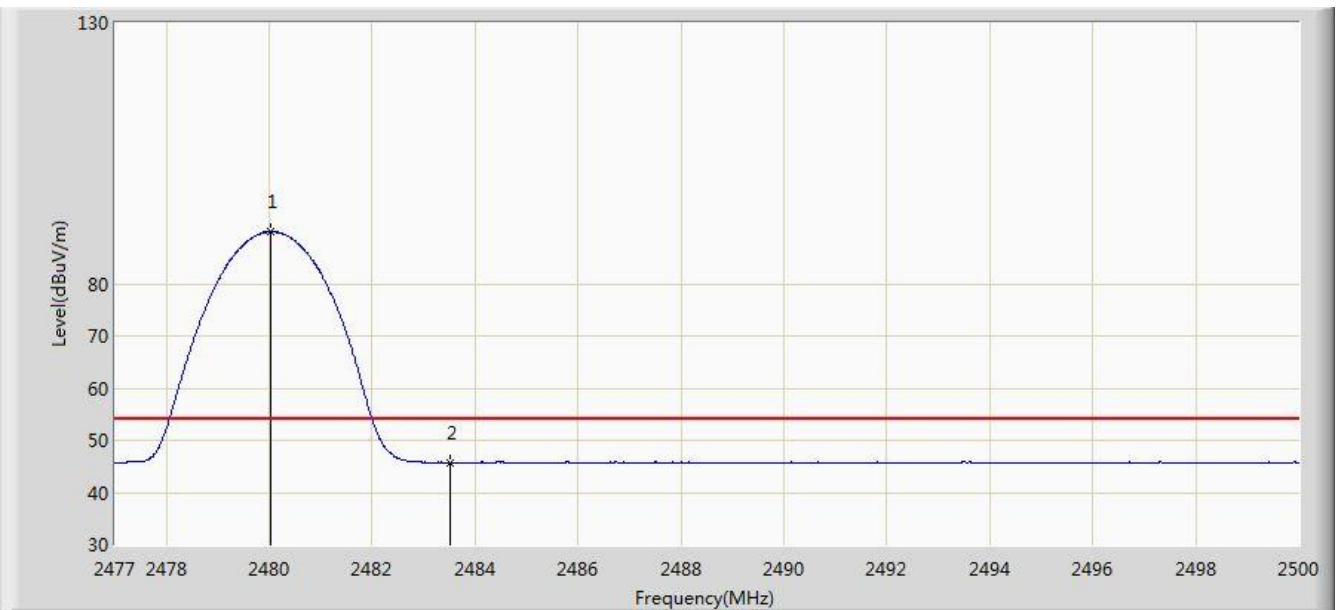

No	Flag	Mark	Frequency (MHz)	Measure Level (dBuV/m)	Reading Level (dBuV)	Over Limit (dB)	Limit (dBuV/m)	Factor (dB)	Type
1		*	2480.036	89.933	58.542	N/A	N/A	31.391	AV
2			2483.500	45.765	14.362	-8.235	54.000	31.403	AV

Note: Measure Level (dB μ V/m) = Reading Level (dB μ V) + Factor (dB)

Factor (dB) = Cable Loss (dB) + Antenna Factor (dB/m)

8. CONCLUSION

The data collected relate only the item(s) tested and show that the **W-LAN + Bluetooth Module** is in compliance with Part 15C of the FCC Rules and IC Rules.

————— The End —————

Appendix A – Test Setup Photograph

Refer to “1904WSU022-UT” file.

Appendix B – EUT Photograph

Refer to “1904WSU022-UE” file.