

# MEASUREMENT REPORT

## FCC PART 15.247 & RSS-247 WLAN

---

**FCC ID:** VPYLBEE59B1LV  
**IC:** 772C-LBEE59B1LV  
**APPLICANT:** Murata Manufacturing Co., Ltd.

**Application Type:** Certification  
**Product:** Communication Module  
**Model No.:** Type1LV  
**FCC Classification:** Digital Transmission System (DTS)  
**FCC Rule Part(s):** Part 15 Subpart C (Section 15.247)  
**IC Rule(s):** RSS-247 Issue 2, RSS-GEN Issue 5  
**Test Procedure(s):** ANSI C63.10-2013, KDB 558074 D01v05r01  
**Test Date:** January 09 ~ March 06, 2019

Reviewed By:

  
( Kevin Guo )

Approved By:

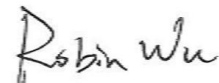
  
( Robin Wu )



The test results relate only to the samples tested.

This equipment has been shown to be capable of compliance with the applicable technical standards as indicated in the measurement report and was tested in accordance with the measurement procedures specified in ANSI C63.10-2013. Test results reported herein relate only to the item(s) tested.

The test report shall not be reproduced except in full without the written approval of MRT Technology (Suzhou) Co., Ltd.

---

## Revision History

Report No.	Version	Description	Issue Date	Note
1901WSU002-U1	Rev. 01	Initial Report	03-28-2019	Valid

---

## CONTENTS

Description	Page
<b>§2.1033 General Information .....</b>	<b>5</b>
<b>1. INTRODUCTION .....</b>	<b>6</b>
1.1. Scope .....	6
1.2. MRT Test Location .....	6
<b>2. PRODUCT INFORMATION .....</b>	<b>7</b>
2.1. Feature of Equipment under Test .....	7
2.2. Product Specification Subjective to this Report.....	7
2.3. Operation Frequency / Channel List .....	8
2.4. Test Mode .....	8
2.5. Description of Test Software.....	8
2.6. Device Capabilities .....	9
2.7. Test Configuration .....	10
2.8. EMI Suppression Device(s)/Modifications.....	10
2.9. Labeling Requirements.....	10
<b>3. DESCRIPTION OF TEST .....</b>	<b>11</b>
3.1. Evaluation Procedure .....	11
3.2. AC Line Conducted Emissions .....	11
3.3. Radiated Emissions.....	12
<b>4. TEST EQUIPMENT CALIBRATION DATE .....</b>	<b>13</b>
<b>5. MEASUREMENT UNCERTAINTY.....</b>	<b>15</b>
<b>6. TEST RESULT .....</b>	<b>16</b>
6.1. Summary .....	16
6.2. 6dB Bandwidth Measurement.....	17
6.2.1. Test Limit .....	17
6.2.2. Test Procedure used.....	17
6.2.3. Test Setting.....	17
6.2.4. Test Setup.....	17
6.2.5. Test Result.....	18
6.3. Output Power Measurement.....	22
6.3.1. Test Limit .....	22
6.3.2. Test Procedure Used .....	22
6.3.3. Test Setting.....	22
6.3.4. Test Setup.....	23

6.3.5.	Test Result.....	24
6.4.	Power Spectral Density Measurement.....	26
6.4.1.	Test Limit.....	26
6.4.2.	Test Procedure Used.....	26
6.4.3.	Test Setting.....	26
6.4.4.	Test Setup.....	26
6.4.5.	Test Result.....	27
6.5.	Conducted Band Edge and Out-of-Band Emissions.....	31
6.5.1.	Test Limit.....	31
6.5.2.	Test Procedure Used.....	31
6.5.3.	Test Setting.....	31
6.5.4.	Test Setup.....	32
6.5.5.	Test Result.....	33
6.6.	Radiated Spurious Emission Measurement.....	40
6.6.1.	Test Limit.....	40
6.6.2.	Test Procedure Used.....	40
6.6.3.	Test Setting.....	40
6.6.4.	Test Setup.....	42
6.6.5.	Test Result.....	43
6.7.	Radiated Restricted Band Edge Measurement.....	54
6.7.1.	Test Limit.....	54
6.7.2.	Test Procedure Used.....	57
6.7.3.	Test Setting.....	57
6.7.4.	Test Setup.....	58
6.7.5.	Test Result.....	59
6.8.	AC Conducted Emissions Measurement.....	83
6.8.1.	Test Limit.....	83
6.8.2.	Test Setup.....	83
6.8.3.	Test Result.....	83
<b>7.</b>	<b>CONCLUSION.....</b>	<b>84</b>
	<b>Appendix A – Test Setup Photograph.....</b>	<b>85</b>
	<b>Appendix B – EUT Photograph.....</b>	<b>86</b>

## §2.1033 General Information

<b>Applicant:</b>	Murata Manufacturing Co., Ltd.
<b>Applicant Address:</b>	10-1, Higashikotari 1-chome, Nagaokakyo-shi, Kyoto 617-8555, Japan
<b>Manufacturer:</b>	Murata Manufacturing Co., Ltd.
<b>Manufacturer Address:</b>	10-1, Higashikotari 1-chome, Nagaokakyo-shi, Kyoto 617-8555, Japan
<b>Test Site:</b>	MRT Technology (Suzhou) Co., Ltd
<b>Test Site Address:</b>	D8 Building, No.2 Tian'edang Rd., Wuzhong Economic Development Zone, Suzhou, China
<b>FCC Registration No.:</b>	893164
<b>IC Registration No.:</b>	11384A-1
<b>Test Device Serial No.:</b>	N/A <input type="checkbox"/> Production <input checked="" type="checkbox"/> Pre-Production <input type="checkbox"/> Engineering

### Test Facility / Accreditations

Measurements were performed at MRT Laboratory located in Tian'edang Rd., Suzhou, China.

- MRT facility is a FCC registered (MRT Reg. No. 893164) test facility with the site description report on file and has met all the requirements specified in ANSI C63.4-2014.
- MRT facility is an IC registered (MRT Reg. No. 11384A-1) test laboratory with the site description on file at Industry Canada.
- MRT facility is a VCCI registered (R-20025, G-20034, C-20020, T-20020) test laboratory with the site description on file at VCCI Council.
- MRT Lab is accredited to ISO 17025 by the American Association for Laboratory Accreditation (A2LA) under the American Association for Laboratory Accreditation Program (A2LA Cert. No. 3628.01) in EMC, Telecommunications, Radio and SAR testing.



# 1. INTRODUCTION

## 1.1. Scope

Measurement and determination of electromagnetic emissions (EMC) of radio frequency devices including intentional and/or unintentional radiators for compliance with the technical rules and regulations of the Federal Communications Commission and the Industry Canada Certification and Engineering Bureau.

## 1.2. MRT Test Location

The map below shows the location of the MRT LABORATORY, its proximity to the Taihu Lake. These measurement tests were conducted at the MRT Technology (Suzhou) Co., Ltd. Facility located at D8 Building, No.2 Tian'edang Rd., Wuzhong Economic Development Zone, Suzhou, China. The measurement facility compliant with the test site requirements specified in ANSI C63.4-2014.



## 2. PRODUCT INFORMATION

### 2.1. Feature of Equipment under Test

Product Name:	Communication Module
Model No.:	Type1LV
Brand Name:	MURATA
Work Voltage:	DC 3.3V
Wi-Fi Specification:	802.11 a/b/g/n/ac
Bluetooth Specification:	BR / EDR / LE 1Mbps / LE 2Mbps

Note: Work voltage for test fixture is DV 5V.

### 2.2. Product Specification Subjective to this Report

Frequency Range	802.11b/g/n-HT20: 2412 ~ 2462MHz
Channel Number:	802.11b/g/n-HT20: 11
Type of Modulation	802.11b: DSSS 802.11g/n: OFDM
Data Rate:	802.11b: 1/2/5.5/11Mbps 802.11g: 6/9/12/18/24/36/48/54Mbps 802.11n: up to 72.2Mbps
Antenna type	PCB Antenna
Antenna Gain	0.9 dBi

Note: For other features of this EUT, test report will be issued separately.

### 2.3. Operation Frequency / Channel List

802.11b/g/n-HT20

Channel	Frequency	Channel	Frequency	Channel	Frequency
01	2412 MHz	02	2417 MHz	03	2422 MHz
04	2427 MHz	05	2432 MHz	06	2437 MHz
07	2442 MHz	08	2447 MHz	09	2452 MHz
10	2457 MHz	11	2462 MHz	--	--

### 2.4. Test Mode

Test Mode	Mode 1: Transmit by 802.11b
	Mode 2: Transmit by 802.11g
	Mode 3: Transmit by 802.11n-HT20

### 2.5. Description of Test Software

The test utility software used during testing was “Tera Term”, and the version was “v4.78”.

#### Power Parameter Value:

Test Mode	Test Frequency (MHz)	Power Parameter Value
11b	2412	77.0
	2437	77.0
	2462	77.0
11g	2412	80.0
	2437	80.0
	2462	80.0
11n-HT20	2412	80.0
	2437	79.0
	2462	80.0



## 2.6. Device Capabilities

This device contains the following capabilities:

2.4GHz WLAN (DTS), 5GHz WLAN (UNII), Bluetooth BR/EDR/LE 1Mbps/LE 2Mbps (DSS/DTS)  
 2.4GHz WLAN (DTS) operation is possible in 20MHz channel bandwidths. The maximum achievable duty cycle was determined based on measurements performed on a spectrum analyzer in zero-span mode with RBW = 8MHz, VBW = 50MHz. The RBW and VBW were both greater than 50/T, where T is the minimum transmission duration, and the number of sweep points across T was greater than 100. The duty cycles are as follows:

Test Mode	Duty Cycle
802.11b	99.88%
802.11g	98.07%
802.11n-HT20	98.17%

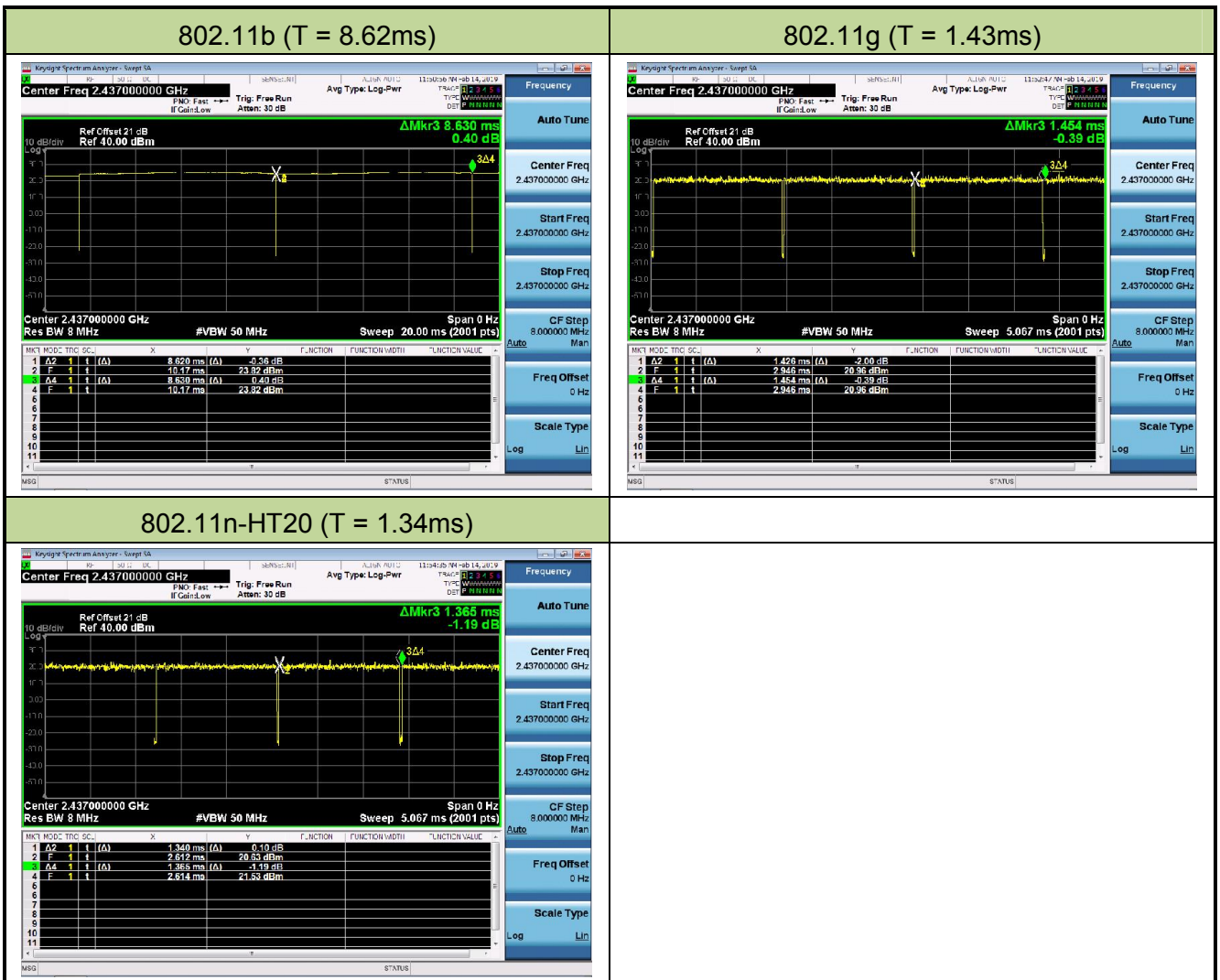

## 2.7. Test Configuration

The **Communication Module** was tested per the guidance of ANSI C63.10-2013. ANSI C63.10-2013 was used to reference the appropriate EUT setup for radiated spurious emissions testing and AC line conducted testing.

## 2.8. EMI Suppression Device(s)/Modifications

No EMI suppression device(s) were added and/or no modifications were made during testing.

## 2.9. Labeling Requirements

Per 2.1074 & 15.19; Docket 95-19

The label shall be permanently affixed at a conspicuous location on the device; instruction manual or pamphlet supplied to the user and be readily visible to the purchaser at the time of purchase. However, when the device is so small wherein placement of the label with specified statement is not practical, only the FCC ID must be displayed on the device per Section 15.19(a)(5). Please see attachment for FCC ID label and label location.

### RSP-100 Issue 11 Section 3

The manufacturer, importer or distributor shall meet the labelling requirements set out in this section for every unit:

- (i) prior to marketing in Canada, for products manufactured in Canada
- (ii) prior to importation into Canada, for imported products

For information regarding the e-labelling option, see Notice 2014–DRS1003. The label for the certified product represents the manufacturer's or importer's compliance with Innovation, Science and Economic Development Canada's (ISED) regulatory requirements.

Please see attachment for IC label and label location.

### 3. DESCRIPTION OF TEST

#### 3.1. Evaluation Procedure

The measurement procedures described in the American National Standard for Testing Unlicensed Wireless Devices (ANSI C63.10-2013), and the guidance provided in KDB 558074 D01v05 were used in the measurement of the device.

**Deviation from measurement procedure.....None**

#### 3.2. AC Line Conducted Emissions

The line-conducted facility is located inside an 8'x4'x4' shielded enclosure. A 1m x 2m wooden table 80cm high is placed 40cm away from the vertical wall and 80cm away from the sidewall of the shielded room. Two 10kHz-30MHz, 50Ω/50uH Line-Impedance Stabilization Networks (LISNs) are bonded to the shielded room floor. Power to the LISNs is filtered by external high-current high-insertion loss power line filters. These filters attenuate ambient signal noise from entering the measurement lines. These filters are also bonded to the shielded enclosure.

The EUT is powered from one LISN and the support equipment is powered from the second LISN. All interconnecting cables more than 1 meter were shortened to a 1 meter length by non-inductive bundling (serpentine fashion) and draped over the back edge of the test table. All cables were at least 40cm above the horizontal reference ground-plane. Power cables for support equipment were routed down to the second LISN while ensuring that that cables were not draped over the second LISN.

Sufficient time for the EUT, support equipment, and test equipment was allowed in order for them to warm up to their normal operating condition. The RF output of the LISN was connected to the receiver and exploratory measurements were made to determine the frequencies producing the maximum emission from the EUT. The receiver was scanned from 150kHz to 30MHz. The detector function was set to peak mode for exploratory measurements while the bandwidth of the analyzer was set to 9kHz. The EUT, support equipment, and interconnecting cables were arranged and manipulated to maximize each emission. Each emission was also maximized by varying: power lines, the mode of operation or data exchange speed, or support equipment whichever determined the worst-case emission. Once the worst case emissions have been identified, the one EUT cable configuration/arrangement and mode of operation that produced these emissions are used for final measurements on the same test site. The analyzer is set to CISPR quasi-peak and average detectors with a 9kHz resolution bandwidth for final measurements.

An extension cord was used to connect to a single LISN which powered by EUT. The extension cord was calibrated with LISN, the impedance and insertion loss are compliance with the requirements as stated in ANSI C63.10-2013.

### 3.3. Radiated Emissions

The radiated test facilities consisted of an indoor 3 meter semi-anechoic chamber used for final measurements and exploratory measurements, when necessary. The measurement area is contained within the semi-anechoic chamber which is shielded from any ambient interference. For measurements above 1GHz absorbers are arranged on the floor between the turn table and the antenna mast in such a way so as to maximize the reduction of reflections. For measurements below 1GHz, the absorbers are removed. A MF Model 210SS turntable is used for radiated measurement. It is a continuously rotatable, remote controlled, metallic turntable and 2 meters (6.56 ft.) in diameter. The turn table is flush with the raised floor of the chamber in order to maintain its function as a ground plane. An 80cm high PVC support structure is placed on top of the turntable.

For all measurements, the spectrum was scanned through all EUT azimuths and from 1 to 4 meter receive antenna height using a broadband antenna from 30MHz up to the upper frequency shown in 15.33(b)(1) depending on the highest frequency generated or used in the device or on which the device operates or tunes. For frequencies above 1GHz, linearly polarized double ridge horn antennas were used. For frequencies below 30MHz, a calibrated loop antenna was used. When exploratory measurements were necessary, they were performed at 1 meter test distance inside the semi-anechoic chamber using broadband antennas, broadband amplifiers, and spectrum analyzers to determine the frequencies and modes producing the maximum emissions. Sufficient time for the EUT, support equipment, and test equipment was allowed in order for them to warm up to their normal operating condition. The test set-up for frequencies below 1GHz was placed on top of the 0.8 meter high, 1 x 1.5 meter table; and test set-up for frequencies 1-25GHz was placed on top of the 1.5 meter high, 1 x 1.5 meter table. The EUT, support equipment, and interconnecting cables were arranged and manipulated to maximize each emission. Appropriate precaution was taken to ensure that all emissions from the EUT were maximized and investigated. The system configuration, clock speed, mode of operation or video resolution, if applicable, turntable azimuth, and receive antenna height was noted for each frequency found.

Final measurements were made in the semi-anechoic chamber using calibrated, linearly polarized broadband and horn antennas. The test setup was configured to the setup that produced the worst case emissions. The spectrum analyzer was set to investigate all frequencies required for testing to compare the highest radiated disturbances with respect to the specified limits. The turntable containing the EUT was rotated through 360 degrees and the height of the receive antenna was varied 1 to 4 meters and stopped at the azimuth and height producing the maximum emission. Each emission was maximized by changing the orientation of the EUT through three orthogonal planes and changing the polarity of the receive antenna, whichever produced the worst-case emissions. According to 3dB Beam-Width of horn antenna, the horn antenna should be always directed to the EUT when rising height.

#### 4. TEST EQUIPMENT CALIBRATION DATE

##### Conducted Emissions - SR2

Instrument	Manufacturer	Type No.	Asset No.	Cali. Interval	Cali. Due Date
EMI Test Receiver	R&S	ESR3	MRTSUE06185	1 year	2019/04/20
Two-Line V-Network	R&S	ENV 216	MRTSUE06002	1 year	2019/06/15
Two-Line V-Network	R&S	ENV 216	MRTSUE06003	1 year	2019/06/15
Thermohygrometer	Testo	608-H1	MRTSUE06404	1 year	2019/08/15
Shielding Anechoic Chamber	Mikebang	Chamber-SR2	MRTSUE06214	N/A	N/A

##### Conducted Test Equipment - TR3

Instrument	Manufacturer	Type No.	Asset No.	Cali. Interval	Cali. Due Date
EXA Signal Analyzer	KEYSIGHT	N9010B	MRTSUE06452	1 year	2019/07/20
Spectrum Analyzer	Agilent	N9020A	MRTSUE06106	1 year	2019/04/20
USB wideband power sensor	KEYSIGHT	U2021XA	MRTSUE06446	1 year	2019/07/20
Attenuator	MVE	MVE2211-10	MRTSUE06800	1 year	2019/07/10
Temperature & Humidity Chamber	BAOYT	BYH-150CL	MRTSUE06051	1 year	2019/12/06
Thermohygrometer	testo	608-H1	MRTSUE06401	1 year	2019/08/15

##### Radiated Emissions - AC1

Instrument	Manufacturer	Type No.	Asset No.	Cali. Interval	Cali. Due Date
EMI Test Receiver	R&S	ESR7	MRTSUE06001	1 year	2019/08/14
PXA Signal Analyzer	Keysight	9030B	MRTSUE06395	1 year	2019/09/14
Loop Antenna	Schwarzbeck	FMZB 1519	MRTSUE06025	1 year	2019/11/20
Bilog Period Antenna	Schwarzbeck	VULB 9168	MRTSUE06172	1 year	2019/04/12
Broad Band Horn Antenna	Schwarzbeck	BBHA 9120D	MRTSUE06023	1 year	2019/10/20
Broad Band Horn Antenna	Schwarzbeck	BBHA 9170	MRTSUE06024	1 year	2019/12/17
Broadband Coaxial Preamp	Agilent	83017A	MRTSUE06076	1 year	2019/11/16
Preamp	Schwarzbeck	BBV 9721	MRTSUE06121	1 year	2019/06/12
Digital Thermometer & Hygrometer	Testo	608-H1	MRTSUE06403	1 year	2019/08/15
Anechoic Chamber	TDK	Chamber-AC1	MRTSUE06213	1 year	2019/05/02

## Radiated Emissions - AC2

Instrument	Manufacturer	Type No.	Asset No.	Cali. Interval	Cali. Due Date
Spectrum Analyzer	Keysight	N9038A	MRTSUE06125	1 year	2019/08/14
Loop Antenna	Schwarzbeck	FMZB 1519	MRTSUE06025	1 year	2019/11/09
Bilog Period Antenna	Schwarzbeck	VULB 9162	MRTSUE06022	1 year	2019/10/20
Horn Antenna	Schwarzbeck	BBHA9120D	MRTSUE06171	1 year	2019/11/09
Broadband Horn Antenna	Schwarzbeck	BBHA9170	MRTSUE06024	1 year	2019/12/17
Broadband Coaxial Preamplifier	Schwarzbeck	BBV 9718	MRTSUE06176	1 year	2019/11/16
Preamplifier	Schwarzbeck	BBV 9721	MRTSUE06121	1 year	2019/06/13
Temperature/Humidity Meter	Minggao	ETH529	MRTSUE06170	1 year	2019/12/13
Anechoic Chamber	RIKEN	Chamber-AC2	MRTSUE06213	1 year	2019/05/02

Software	Version	Function
e3	V 8.3.5	EMI Test Software

## 5. MEASUREMENT UNCERTAINTY

Where relevant, the following test uncertainty levels have been estimated for tests performed on the EUT as specified in CISPR 16-4-2. This uncertainty represents an expanded uncertainty expressed at approximately the 95% confidence level using a coverage factor of  $k = 2$ .

<b>AC Conducted Emission Measurement - SR2</b>
Measuring Uncertainty for a Level of Confidence of 95% ( $U=2Uc(y)$ ): 150kHz~30MHz: 3.46dB
<b>Radiated Emission Measurement - AC1</b>
Measuring Uncertainty for a Level of Confidence of 95% ( $U=2Uc(y)$ ): 9kHz ~ 1GHz: 4.18dB 1GHz ~ 25GHz: 4.76dB
<b>Radiated Emission Measurement - AC2</b>
Measuring Uncertainty for a Level of Confidence of 95% ( $U=2Uc(y)$ ): 9kHz ~ 1GHz: 3.86dB 1GHz ~ 25GHz: 4.33dB
<b>Spurious Emissions, Conducted - TR3</b>
Measuring Uncertainty for a Level of Confidence of 95% ( $U=2Uc(y)$ ): 0.78dB
<b>Output Power - TR3</b>
Measuring Uncertainty for a Level of Confidence of 95% ( $U=2Uc(y)$ ): 1.13dB
<b>Power Spectrum Density - TR3</b>
Measuring Uncertainty for a Level of Confidence of 95% ( $U=2Uc(y)$ ): 1.15dB
<b>Occupied Bandwidth - TR3</b>
Measuring Uncertainty for a Level of Confidence of 95% ( $U=2Uc(y)$ ): 0.28%

## 6. TEST RESULT

### 6.1. Summary

**Company Name:** Murata Manufacturing Co., Ltd.

**FCC ID:** VPYLBEE59B1LV

**IC:** 772C-LBEE59B1LV

FCC Section(s)	IC Section(s)	Test Description	Test Limit	Test Condition	Test Result	Reference
15.247(a)(2)	RSS-247 [5.2]	6dB Bandwidth	$\geq 500\text{kHz}$	Conducted	Pass	Section 6.2
15.247(b)(3)	RSS-247 [5.4(4)]	Output Power	$\leq 30\text{dBm}$		Pass	Section 6.3
15.247(e)	RSS-247 [5.2]	Power Spectral Density	$\leq 8\text{dBm}/3\text{kHz}$		Pass	Section 6.4
15.247(d)	RSS-247 [5.5]	Band Edge / Out-of-Band Emissions	$\leq 20\text{dBc(Peak)}$		Pass	Section 6.5
15.205 15.209	RSS-247 [5.5]	General Field Strength Limits (Restricted Bands and Radiated Emission Limits)	Emissions in restricted bands must meet the radiated limits detailed in 15.209	Radiated	Pass	Section 6.6 & 6.7
15.207	RSS-Gen [8.8]	AC Conducted Emissions 150kHz - 30MHz	< FCC 15.207 limits	Line Conducted	N/A	Section 6.8

#### Notes:

- 1) The analyzer plots shown in this section were all taken with a correction table loaded into the analyzer. The correction table was used to account for the losses of the cables and attenuators used as part of the system to connect the EUT to the analyzer at all frequencies of interest.
- 2) All modes of operation and data rates were investigated. For radiated emission test, every axis (X, Y, Z) was also verified. The test results shown in the following sections represent the worst case emissions.
- 3) N/A means Not Applicable.



## 6.2. 6dB Bandwidth Measurement

### 6.2.1. Test Limit

The minimum 6dB bandwidth shall be at least 500 kHz.

### 6.2.2. Test Procedure used

ANSI C63.10-2013 - Section 11.8.2 Option 2

### 6.2.3. Test Setting

1. The Spectrum's automatic bandwidth measurement capability was used to perform the 6dB bandwidth measurement. The "X" dB bandwidth parameter was set to  $X = 6$ . The bandwidth measurement was not influenced by any intermediate power nulls in the fundamental emission.
2. Set RBW = 100 kHz
3. VBW  $\geq 3 \times$  RBW
4. Detector = Peak
5. Trace mode = max hold
6. Sweep = auto couple
7. Allow the trace was allowed to stabilize

### 6.2.4. Test Setup

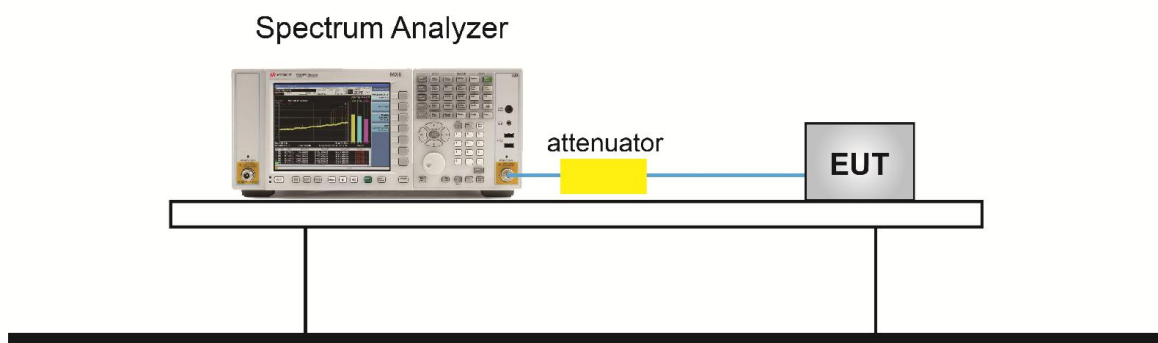

**6.2.5. Test Result**

Product	Communication Module	Temperature	23°C
Test Engineer	Dandy Li	Relative Humidity	54%
Test Site	TR3	Test Date	2019/02/14

Test Mode	Data Rate / MCS	Channel No.	Frequency (MHz)	6dB Bandwidth (MHz)	Limit (MHz)	Result
802.11b	1Mbps	01	2412	8.60	≥0.5	Pass
802.11b	1Mbps	06	2437	9.03	≥0.5	Pass
802.11b	1Mbps	11	2462	9.06	≥0.5	Pass
802.11g	6Mbps	01	2412	16.40	≥0.5	Pass
802.11g	6Mbps	06	2437	16.42	≥0.5	Pass
802.11g	6Mbps	11	2462	16.40	≥0.5	Pass
802.11n-HT20	MCS0	01	2412	17.62	≥0.5	Pass
802.11n-HT20	MCS0	06	2437	17.63	≥0.5	Pass
802.11n-HT20	MCS0	11	2462	17.63	≥0.5	Pass

802.11b 6dB Bandwidth

Channel 01 (2412MHz)



Channel 06 (2437MHz)



Channel 11 (2462MHz)



802.11g 6dB Bandwidth

Channel 01 (2412MHz)

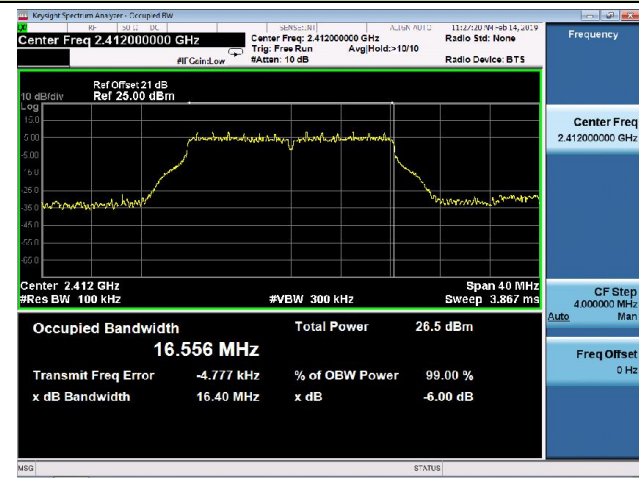

Channel 06 (2437MHz)

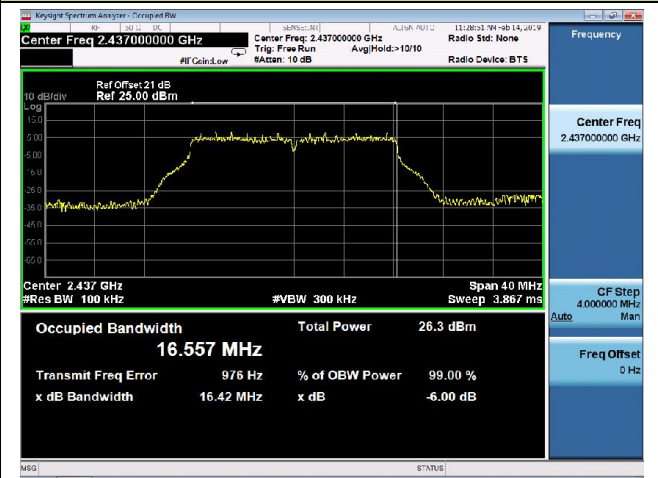

Channel 11 (2462MHz)



802.11n-HT20 6dB Bandwidth

Channel 01 (2412MHz)

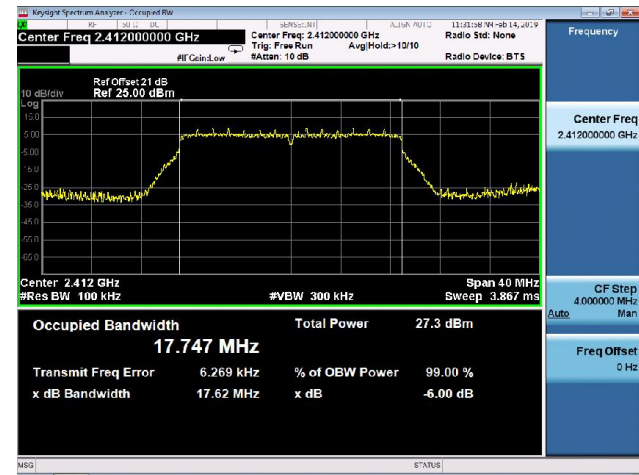

Channel 06 (2437MHz)

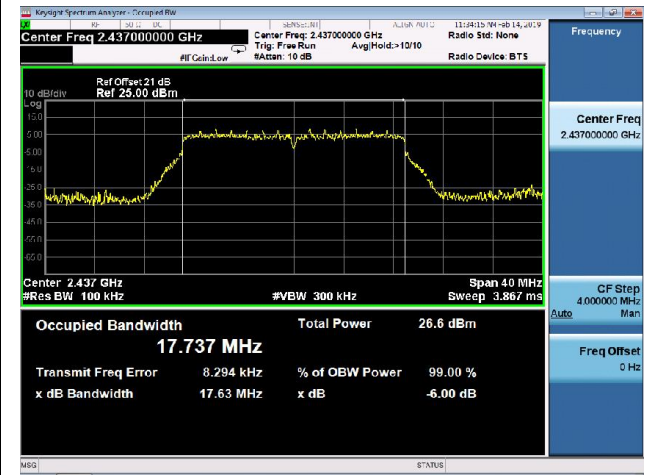

Channel 11 (2462MHz)

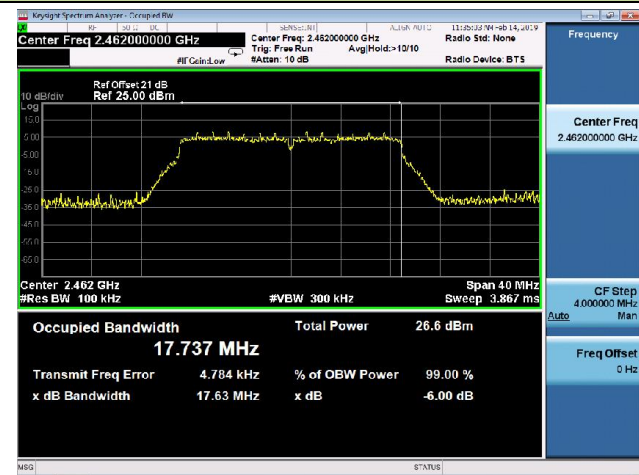

### **6.3. Output Power Measurement**

#### **6.3.1. Test Limit**

The maximum conducted output power shall be exceed 1 Watt (30dBm) and the E.I.R.P shall not exceed 4 Watt (36dBm).

#### **6.3.2. Test Procedure Used**

ANSI C63.10-2013 - Section 11.9.1.3 PKPM1 Peak-reading power meter method

ANSI C63.10-2013 - Section 11.9.2.3.2 Method AVGPM-G

#### **6.3.3. Test Setting**

##### **Method PKPM1 (Peak power measurement)**

Peak power measurements were performed only when the EUT was transmitting at its maximum power control level using a broadband power meter with a pulse sensor. The pulse sensor employs a VBW = 50MHz so this method was only used for signals whose DTS bandwidth was less than or equal to 50MHz.

##### **Method AVGPM-G (Measurement using a gated RF average-reading power meter)**

Measurements may be performed using a wideband gated RF power meter provided that the gate parameters are adjusted such that the power is measured only when the EUT is transmitting at its maximum power control level. Since this measurement is made only during the ON time of the transmitter, no duty cycle correction is required.

### 6.3.4. Test Setup

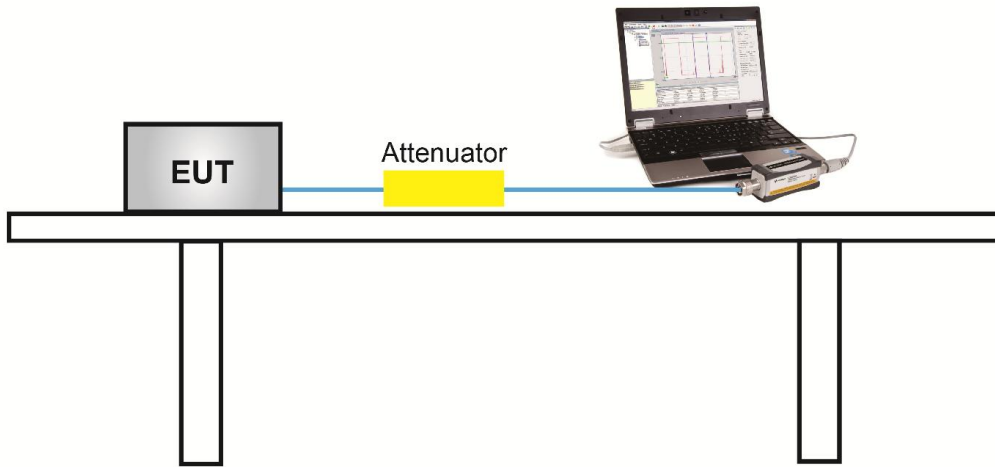

### 6.3.5. Test Result

Power output test was verified over all data rates of each mode shown as below, and then choose the maximum power output (gray marker) for final test of each channel.

Output power at various data rates:

Test Mode	Bandwidth (MHz)	Channel No.	Frequency (MHz)	Data Rate / MCS	Average Power (dBm)
802.11b	20	06	2437	1Mbps	18.86
				5.5Mbps	18.64
				11Mbps	18.37
802.11g	20	06	2437	6Mbps	18.88
				24Mbps	18.45
				54Mbps	18.22
802.11n	20	06	2437	MCS0	18.51
				MCS3	18.13
				MCS7	17.89



Product	Communication Module	Temperature	23°C
Test Engineer	Dandy Li	Relative Humidity	54%
Test Site	TR3	Test Date	2019/01/10

**Test Result of Peak Output Power**

Test Mode	Data Rate / MCS	Channel No.	Freq. (MHz)	Peak Power (dBm)	Power Limit (dBm)	EIRP (dBm)	EIRP Limit (dBm)	Result
11b	1Mbps	01	2412	22.01	≤ 30.00	22.91	≤ 36.00	Pass
11b	1Mbps	06	2437	22.06	≤ 30.00	22.96	≤ 36.00	Pass
11b	1Mbps	11	2462	21.95	≤ 30.00	22.85	≤ 36.00	Pass
11g	6Mbps	01	2412	25.48	≤ 30.00	26.38	≤ 36.00	Pass
11g	6Mbps	06	2437	25.71	≤ 30.00	26.61	≤ 36.00	Pass
11g	6Mbps	11	2462	25.25	≤ 30.00	26.15	≤ 36.00	Pass
11n-HT20	MCS0	01	2412	25.78	≤ 30.00	26.68	≤ 36.00	Pass
11n-HT20	MCS0	06	2437	25.54	≤ 30.00	26.44	≤ 36.00	Pass
11n-HT20	MCS0	11	2462	25.29	≤ 30.00	26.19	≤ 36.00	Pass

Note: EIRP (dBm) = Peak Power (dBm) + Antenna Gain (dBi), Antenna Gain (dBi) = 0.9dBi.

**Test Result of Average Output Power (Reporting Only)**

Test Mode	Data Rate / MCS	Channel No.	Freq. (MHz)	Average Power (dBm)	Power Limit (dBm)	EIRP (dBm)	EIRP Limit (dBm)	Result
11b	1Mbps	01	2412	18.81	≤ 30.00	19.71	≤ 36.00	Pass
11b	1Mbps	06	2437	18.86	≤ 30.00	19.76	≤ 36.00	Pass
11b	1Mbps	11	2462	18.77	≤ 30.00	19.67	≤ 36.00	Pass
11g	6Mbps	01	2412	18.93	≤ 30.00	19.83	≤ 36.00	Pass
11g	6Mbps	06	2437	18.88	≤ 30.00	19.78	≤ 36.00	Pass
11g	6Mbps	11	2462	18.91	≤ 30.00	19.81	≤ 36.00	Pass
11n-HT20	MCS0	01	2412	18.82	≤ 30.00	19.72	≤ 36.00	Pass
11n-HT20	MCS0	06	2437	18.51	≤ 30.00	19.41	≤ 36.00	Pass
11n-HT20	MCS0	11	2462	18.90	≤ 30.00	19.80	≤ 36.00	Pass

Note: EIRP (dBm) = Average Power (dBm) + Antenna Gain (dBi), Antenna Gain (dBi) = 0.9dBi.

## 6.4. Power Spectral Density Measurement

### 6.4.1. Test Limit

The maximum permissible power spectral density is 8dBm in any 3 kHz band.

### 6.4.2. Test Procedure Used

ANSI C63.10 Section 11.10.2

### 6.4.3. Test Setting

1. Analyzer was set to the center frequency of the DTS channel under investigation
2. Span = 1.5 times the DTS channel bandwidth
3. RBW = 3kHz
4. VBW = 10kHz
5. Detector = peak
6. Sweep time = auto couple
7. Trace mode = max hold
8. Trace was allowed to stabilize

### 6.4.4. Test Setup

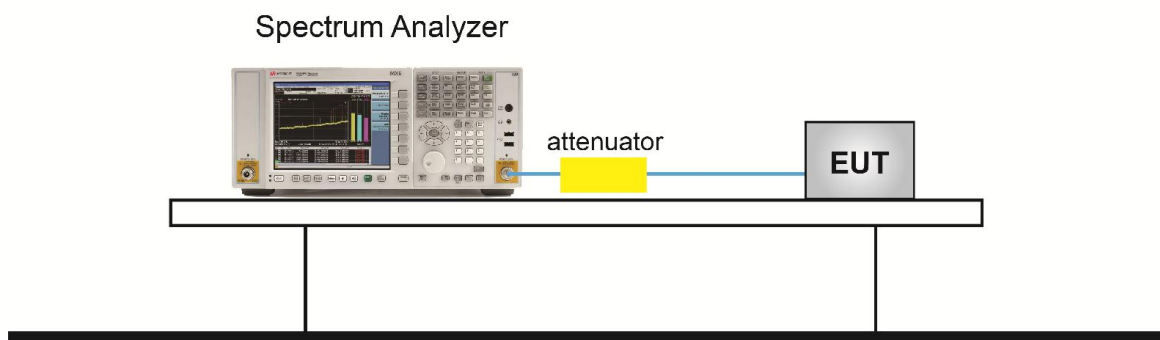

#### 6.4.5. Test Result

Product	Communication Module	Temperature	23°C
Test Engineer	Dandy Li	Relative Humidity	54%
Test Site	TR3	Test Date	2019/02/14

Test Mode	Data Rate / MCS	Channel No.	Freq. (MHz)	Peak PSD (dBm/3kHz)	Limit (dBm/3kHz)	Result
11b	1Mbps	01	2412	-2.18	≤ 8.0	Pass
11b	1Mbps	06	2437	-3.81	≤ 8.0	Pass
11b	1Mbps	11	2462	-3.33	≤ 8.0	Pass
11g	6Mbps	01	2412	-4.06	≤ 8.0	Pass
11g	6Mbps	06	2437	-4.31	≤ 8.0	Pass
11g	6Mbps	11	2462	-5.44	≤ 8.0	Pass
11n-HT20	MCS0	01	2412	-4.74	≤ 8.0	Pass
11n-HT20	MCS0	06	2437	-4.44	≤ 8.0	Pass
11n-HT20	MCS0	11	2462	-5.61	≤ 8.0	Pass

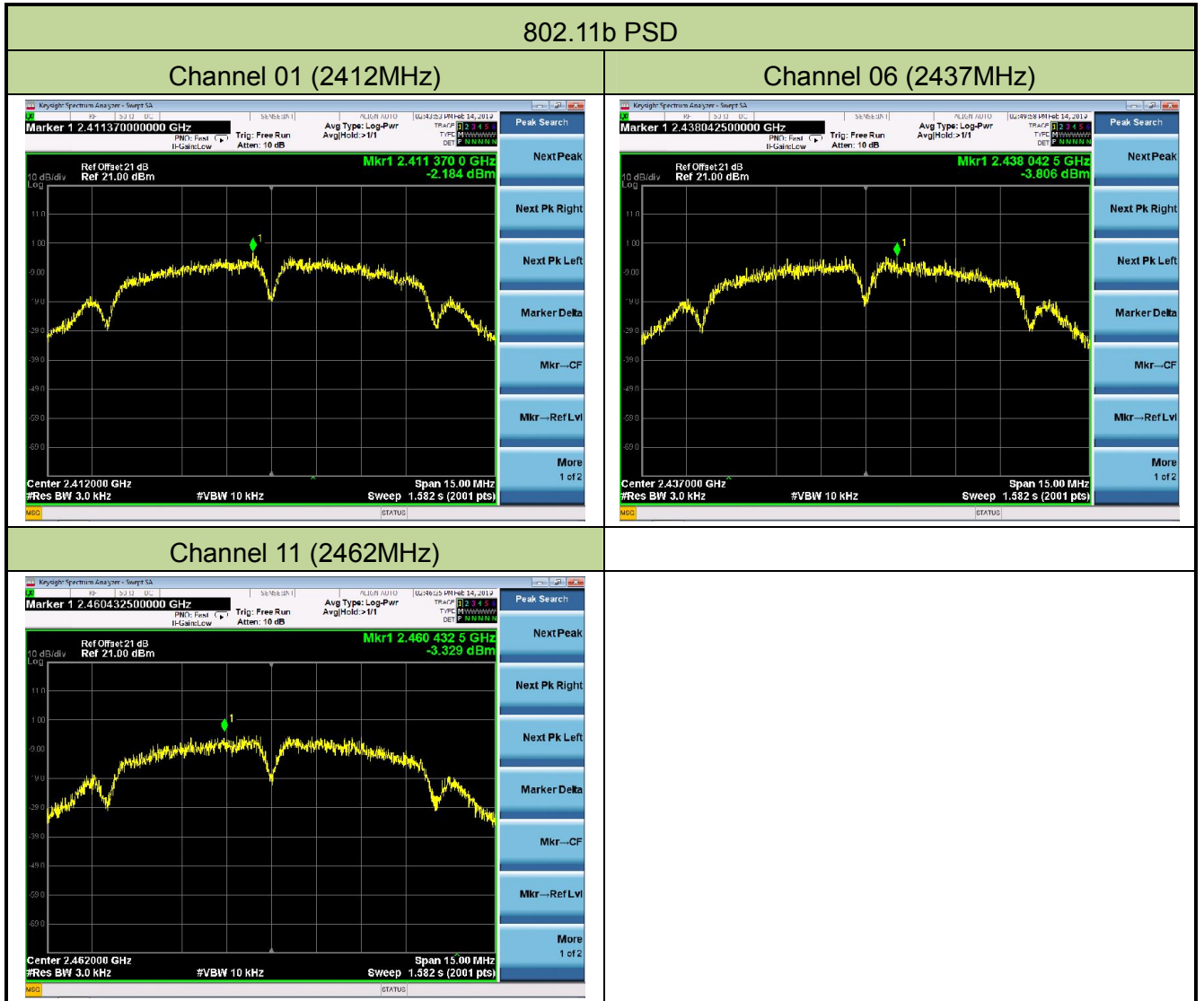



802.11n-HT20 PSD

Channel 01 (2412MHz)

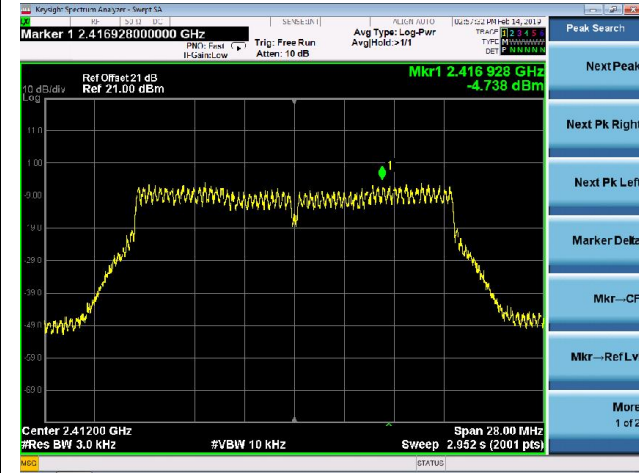

Channel 06 (2437MHz)

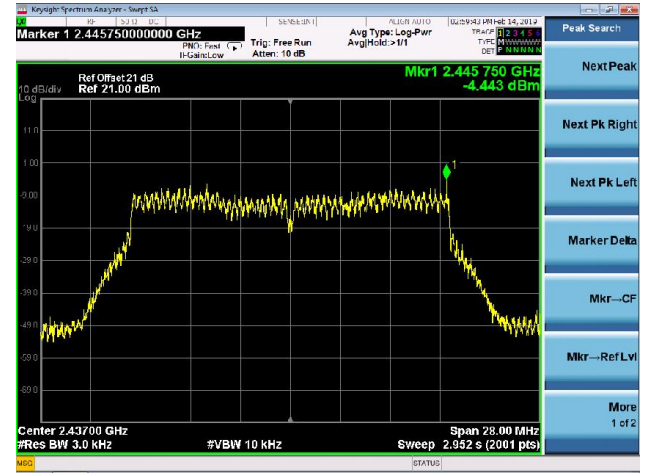

Channel 11 (2462MHz)

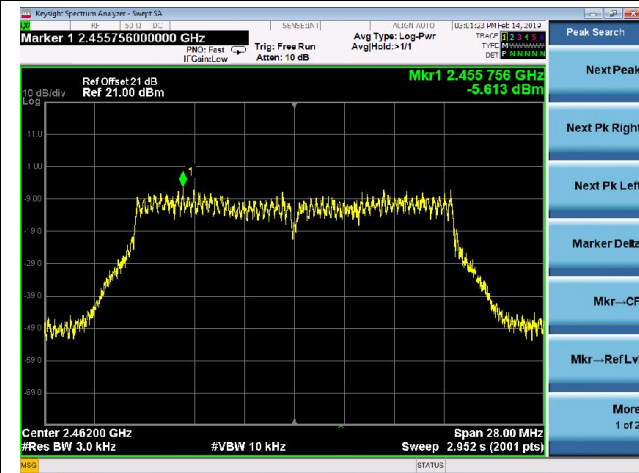

## **6.5. Conducted Band Edge and Out-of-Band Emissions**

### **6.5.1. Test Limit**

The limit for out-of-band spurious emissions at the band edge is 20dB below the fundamental emission level, as determined from the in-band power measurement of the DTS channel performed in a 100 kHz bandwidth per the PSD procedure.

### **6.5.2. Test Procedure Used**

ANSI C63.10 Section 11.11

### **6.5.3. Test Setting**

#### **Reference level measurement**

1. Set instrument center frequency to DTS channel center frequency
2. Set the span to  $\geq 1.5$  times the DTS bandwidth
3. Set the RBW = 100 kHz
4. Set the VBW  $\geq 3 \times$  RBW
5. Detector = peak
6. Sweep time = auto couple
7. Trace mode = max hold
8. Allow trace to fully stabilize

#### **Emission level measurement**

1. Set the center frequency and span to encompass frequency range to be measured
2. RBW = 1.3MHz
3. VBW = 4MHz
4. Detector = Peak
5. Trace mode = max hold
6. Sweep time = auto couple
7. The trace was allowed to stabilize

### Test Notes

1. RBW was set to 1.3MHz rather than 100 kHz in order to increase the measurement speed.
2. The display line shown in the following plots denotes the limit at 20dB below the fundamental emission level measured in a 100 kHz bandwidth. However, since the traces in the following plots are measured with a 1.3MHz RBW, the display line may not necessarily appear to be 20dB below the level of the fundamental in a 1.3MHz bandwidth.
3. For plots showing conducted spurious emissions near the limit, the frequencies were investigated with a reduced RBW to ensure that no emissions were present.

### 6.5.4. Test Setup

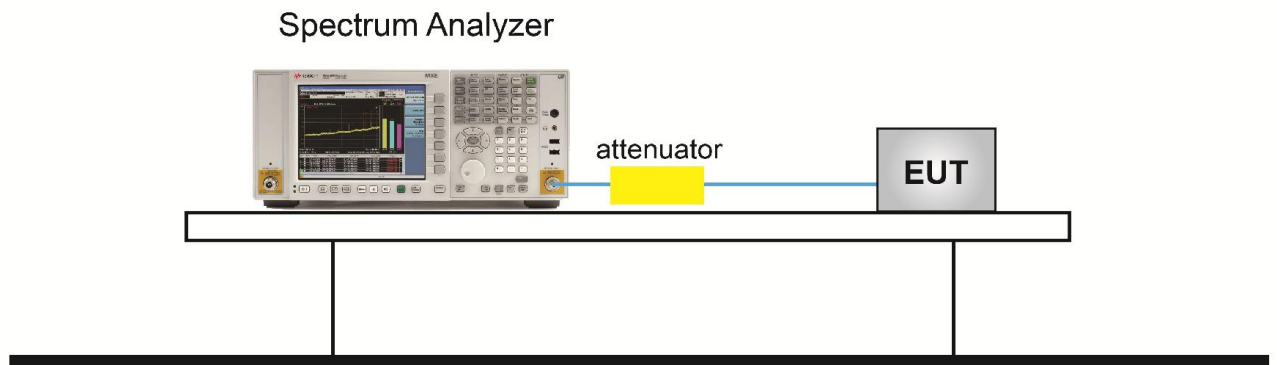



**6.5.5. Test Result**

Product	Communication Module	Temperature	23°C
Test Engineer	Dandy Li	Relative Humidity	54%
Test Site	TR3	Test Date	2019/02/14

Test Mode	Data Rate / MCS	Channel No.	Frequency (MHz)	Limit	Result
11b	1Mbps	01	2412	20dBc	Pass
11b	1Mbps	06	2437	20dBc	Pass
11b	1Mbps	11	2462	20dBc	Pass
11g	6Mbps	01	2412	20dBc	Pass
11g	6Mbps	06	2437	20dBc	Pass
11g	6Mbps	11	2462	20dBc	Pass
11n-HT20	MCS0	01	2412	20dBc	Pass
11n-HT20	MCS0	06	2437	20dBc	Pass
11n-HT20	MCS0	11	2462	20dBc	Pass

### 802.11b Out-of-Band Emissions

#### Channel 01 (2412MHz)

##### 100kHz PSD Reference Level



##### Low Band Edge



##### Spurious Emission

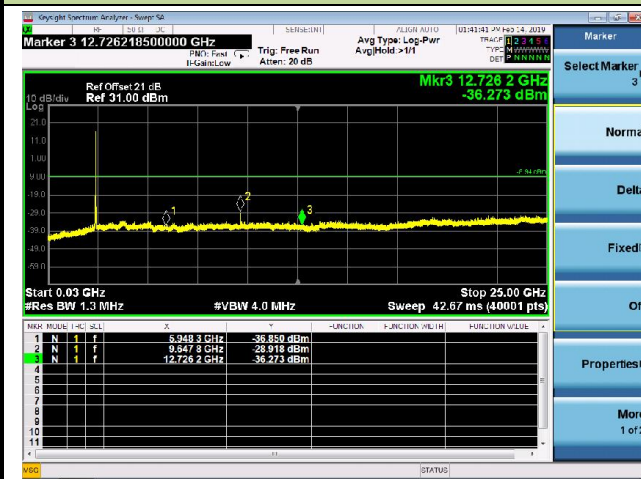

#### Channel 06 (2437MHz)

##### 100kHz PSD Reference Level



##### Spurious Emission

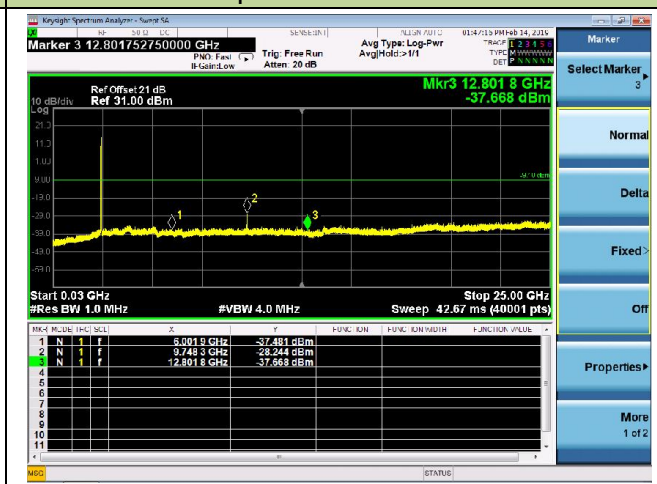

Channel 11 (2462MHz)

100kHz PSD Reference Level



High Band Edge

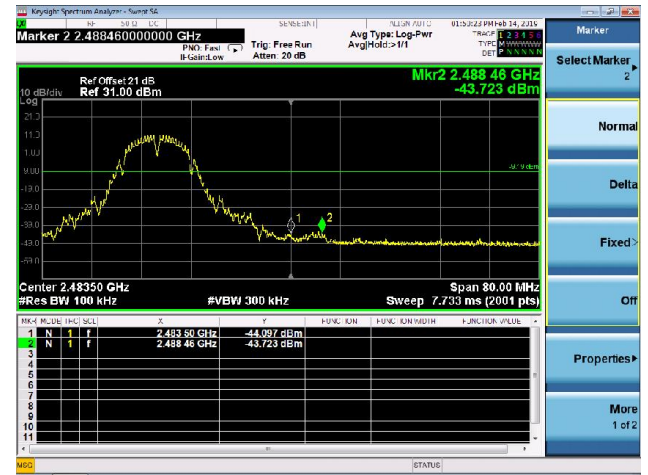

Spurious Emission



802.11g Out-of-Band Emissions  
Channel 01 (2412MHz)

100kHz PSD Reference Level



Low Band Edge

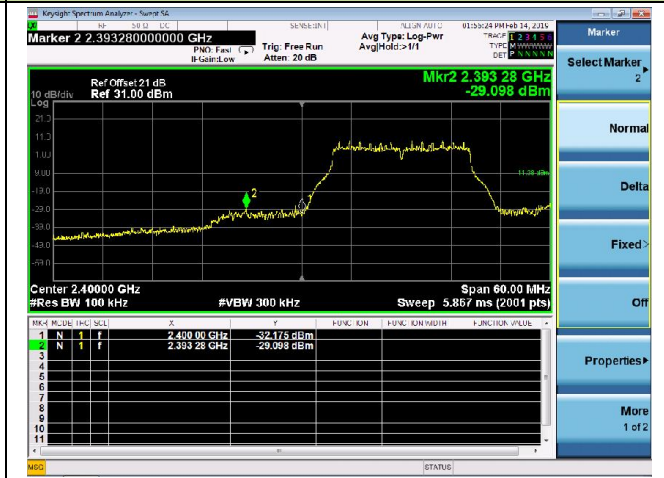

Spurious Emission

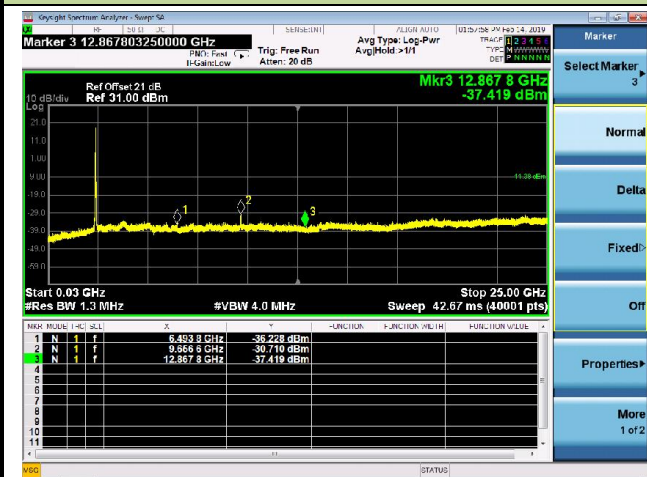

Channel 06 (2437MHz)

100kHz PSD Reference Level



Spurious Emission

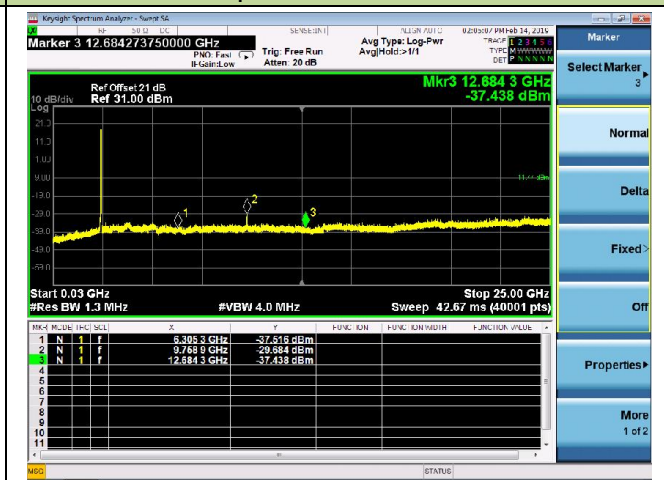

Channel 11 (2462MHz)

100kHz PSD Reference Level



High Band Edge

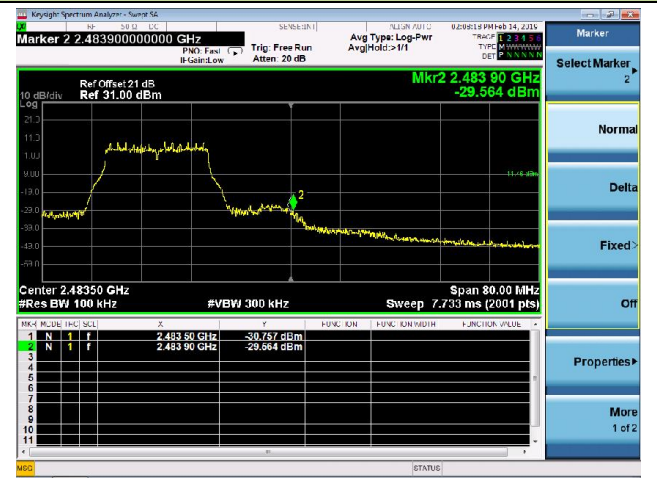

Spurious Emission



802.11n-HT20 Out-of-Band Emissions

Channel 01 (2412MHz)

100kHz PSD Reference Level

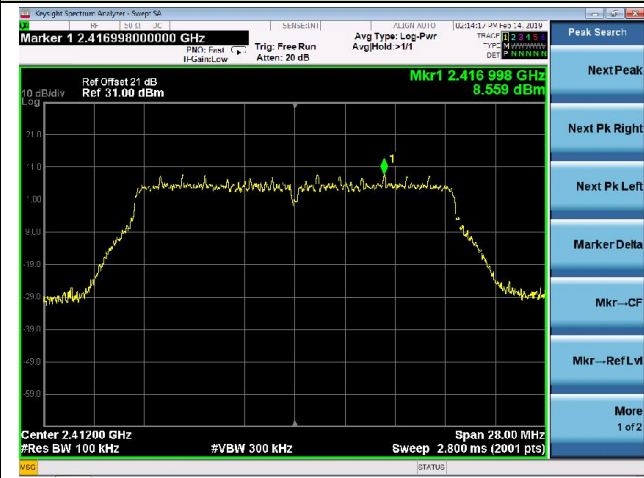

Low Band Edge

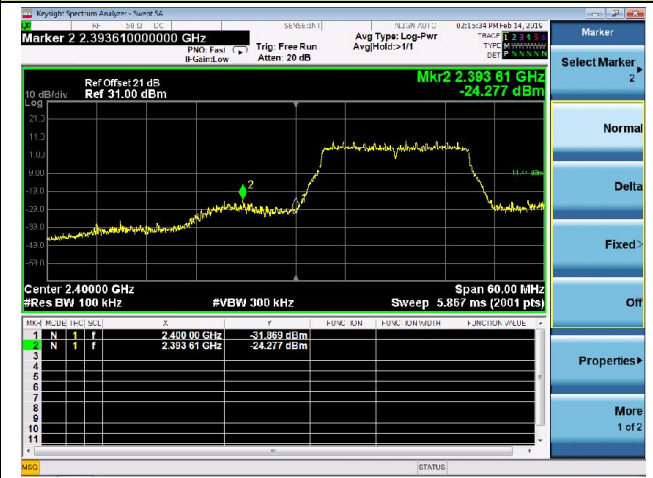

Spurious Emission

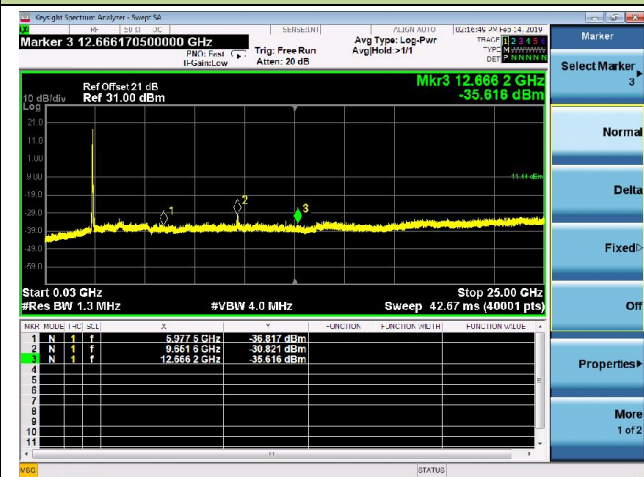

Channel 06 (2437MHz)

100kHz PSD Reference Level

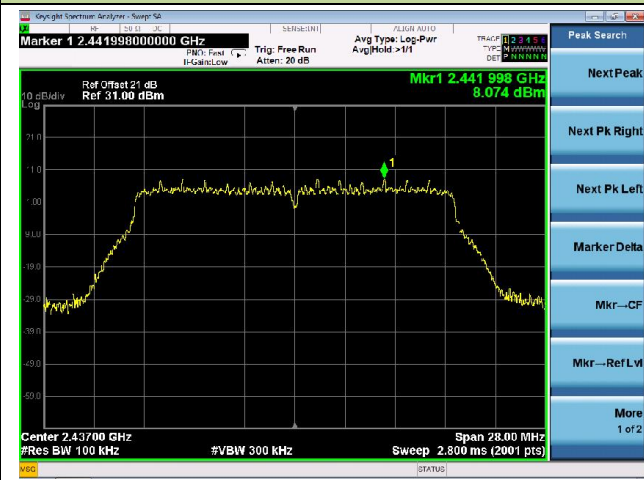

Spurious Emission

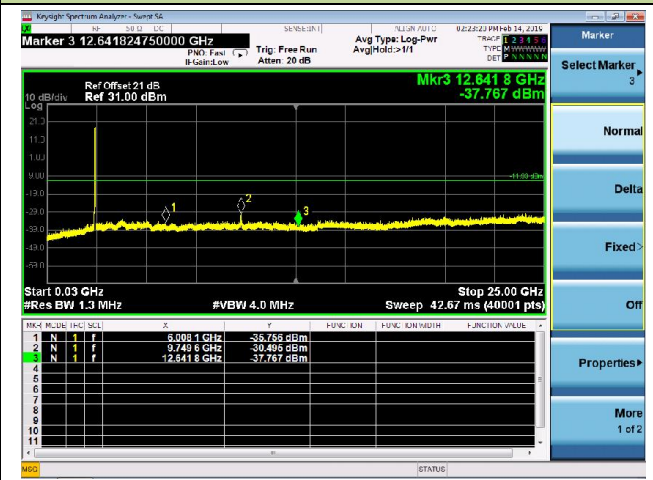

Channel 11 (2462MHz)

100kHz PSD Reference Level



High Band Edge

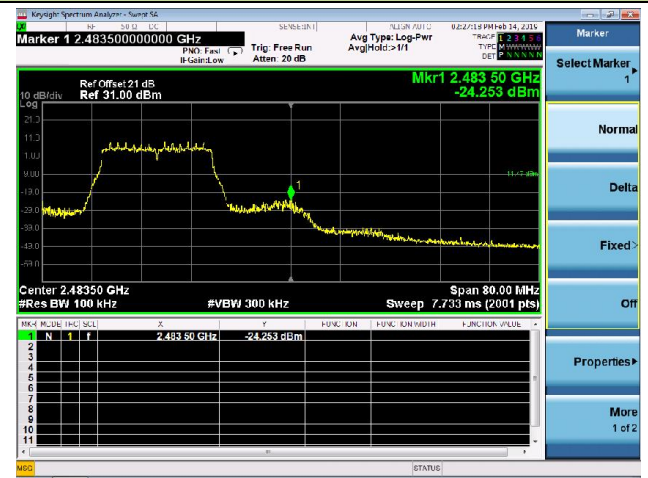

Spurious Emission

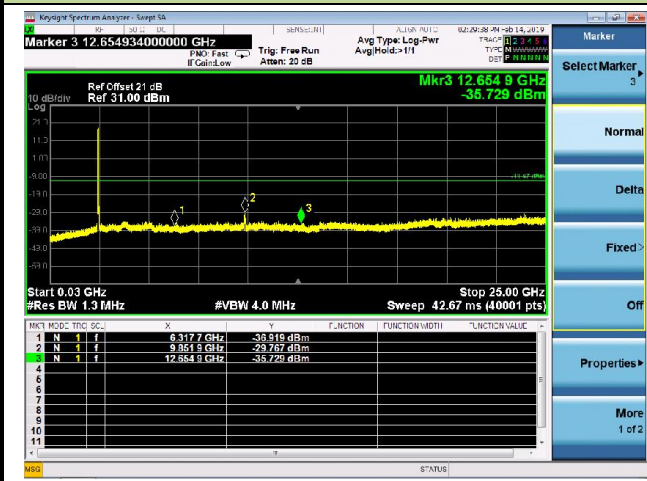

**6.6. Radiated Spurious Emission Measurement**

**6.6.1. Test Limit**

All out of band emissions appearing in a restricted band as specified in Section 15.205 of the Title 47 CFR must not exceed the limits shown in Table per Section 15.209.

FCC Part 15 Subpart C Paragraph 15.209		
Frequency [MHz]	Field Strength [uV/m]	Measured Distance [Meters]
0.009 - 0.490	2400/F (kHz)	300
0.490 - 1.705	24000/F (kHz)	30
1.705 - 30	30	30
30 - 88	100	3
88 - 216	150	3
216 - 960	200	3
Above 960	500	3

**6.6.2. Test Procedure Used**

ANSI C63.10 Section 6.3 (General Requirements)

ANSI C63.10 Section 6.4 (Standard test method below 30MHz)

ANSI C63.10 Section 6.5 (Standard test method above 30MHz to 1GHz)

ANSI C63.10 Section 6.6 (Standard test method above 1GHz)

**6.6.3. Test Setting**

**Table 1 - RBW as a function of frequency**

Frequency	RBW
9 ~ 150 kHz	200 ~ 300 Hz
0.15 ~ 30 MHz	9 ~ 10 kHz
30 ~ 1000 MHz	100 ~ 120 kHz
> 1000 MHz	1 MHz



**Quasi-Peak Measurements below 1GHz**

1. Analyzer center frequency was set to the frequency of the radiated spurious emission of interest
2. Span was set greater than 1MHz
3. RBW = as specified in Table 1
4. Detector = CISPR quasi-peak
5. Sweep time = auto couple
6. Trace was allowed to stabilize

**Peak Measurements above 1GHz**

1. Analyzer center frequency was set to the frequency of the radiated spurious emission of interest
2. RBW = 1MHz
3. VBW = 3MHz
4. Detector = peak
5. Sweep time = auto couple
6. Trace mode = max hold
7. Trace was allowed to stabilize

**Average Measurements above 1GHz (Method VB)**

1. Analyzer center frequency was set to the frequency of the radiated spurious emission of interest
2. RBW = 1MHz
3. VBW; If the EUT is configured to transmit with duty cycle  $\geq 98\%$ , set VBW = 10 Hz.  
If the EUT duty cycle is  $< 98\%$ , set VBW  $\geq 1/T$ . T is the minimum transmission duration.
4. Detector = Peak
5. Sweep time = auto
6. Trace mode = max hold
7. Trace was allowed to stabilize

### 6.6.4. Test Setup

#### Below 1GHz Test Setup:

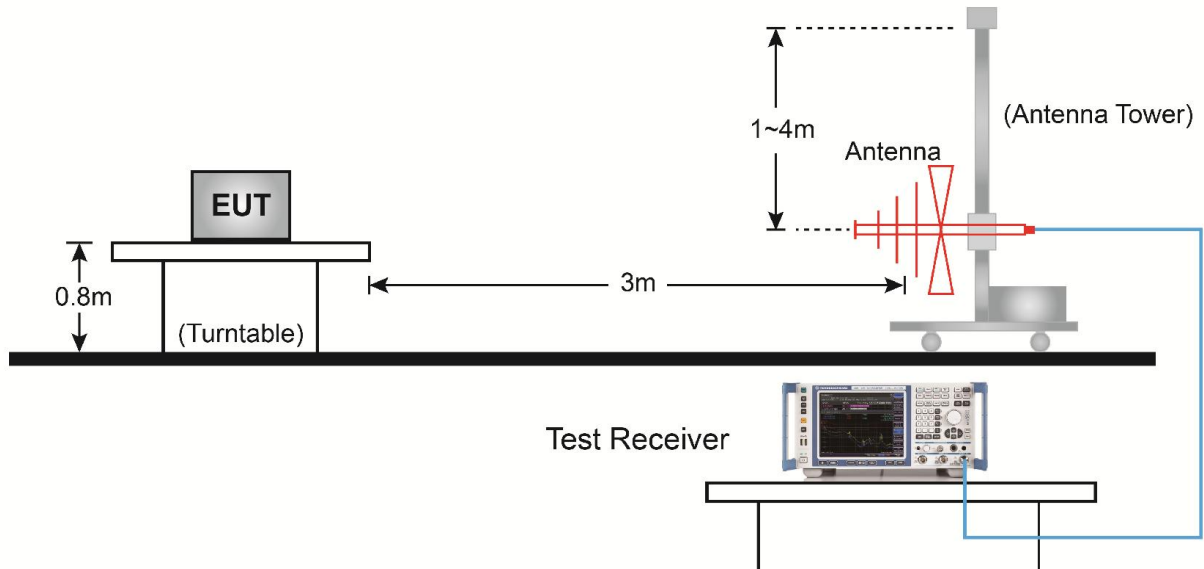

#### Above 1GHz Test Setup:

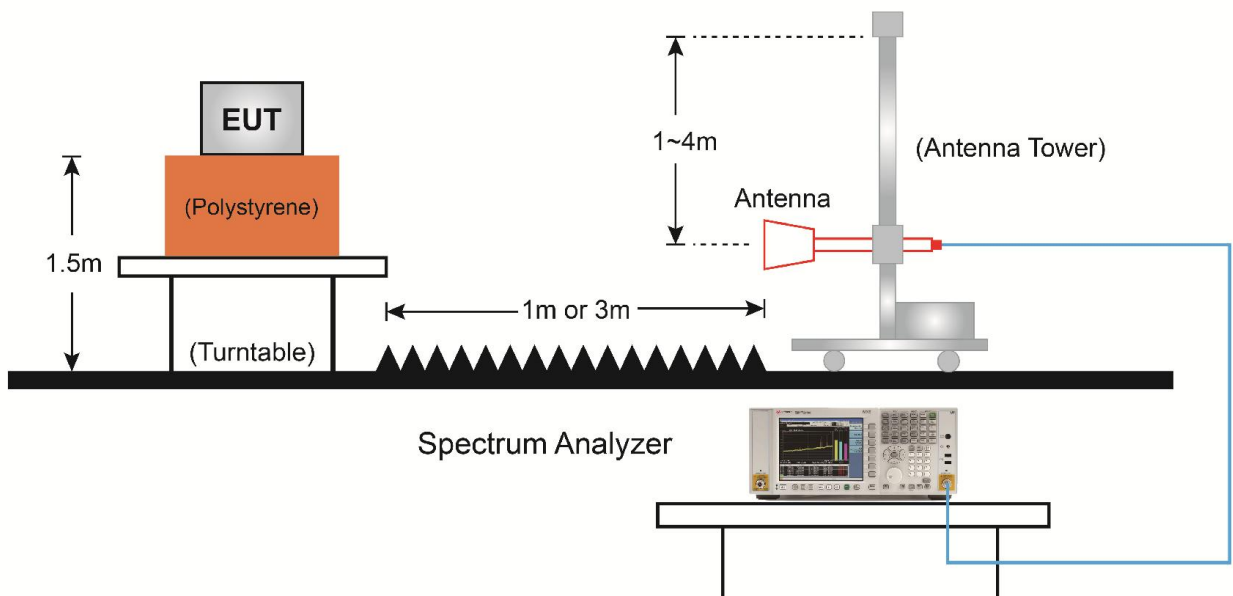

**6.6.5. Test Result**

Product	Communication Module	Temperature	26°C
Test Engineer	Jone Zhang	Relative Humidity	56%
Test Site	AC1	Test Date	2019/01/17
Test Mode	802.11b	Test Channel	01
Remark:	1. Average measurement was not performed if peak level lower than average limit. 2. Other frequency was 20dB below limit line within 1-18GHz, there is not show in the report.		

Mark	Frequency (MHz)	Reading Level (dBμV)	Factor (dB)	Measure Level (dBμV/m)	Limit (dBμV/m)	Margin (dB)	Detector	Polarization
	3813.5	40.2	2.8	43.0	74.0	-31.0	Peak	Horizontal
	4825.0	37.0	5.9	42.9	74.0	-31.1	Peak	Horizontal
*	7230.5	39.4	12.7	52.1	87.7	-35.6	Peak	Horizontal
*	9644.5	45.9	15.5	61.4	87.7	-26.3	Peak	Horizontal
	4927.0	37.0	6.1	43.1	74.0	-30.9	Peak	Vertical
	7417.5	35.9	12.7	48.6	74.0	-25.4	Peak	Vertical
*	7944.5	36.1	13.5	49.6	87.7	-38.1	Peak	Vertical
*	9644.5	48.1	15.5	63.6	87.7	-24.1	Peak	Vertical

Note 1: "\*" is not in restricted band, its limit is 20dBc of the fundamental emission level (107.7dBμV/m) or 15.209 which is higher.

Note 2: Measure Level (dBμV/m) = Reading Level (dBμV) + Factor (dB)

Factor (dB) = Cable Loss (dB) + Antenna Factor (dB/m) - Pre\_Amplifier Gain (dB)

Product	Communication Module	Temperature	26°C
Test Engineer	Jone Zhang	Relative Humidity	56%
Test Site	AC1	Test Date	2019/01/17
Test Mode	802.11b	Test Channel	06
Remark:	1. Average measurement was not performed if peak level lower than average limit. 2. Other frequency was 20dB below limit line within 1-18GHz, there is not show in the report.		

Mark	Frequency (MHz)	Reading Level (dBμV)	Factor (dB)	Measure Level (dBμV/m)	Limit (dBμV/m)	Margin (dB)	Detector	Polarization
	4876.0	36.6	6.0	42.6	74.0	-31.4	Peak	Horizontal
	7307.0	37.0	12.5	49.5	74.0	-24.5	Peak	Horizontal
*	7919.0	36.2	13.4	49.6	88.0	-38.4	Peak	Horizontal
*	9746.5	45.9	16.1	62.0	88.0	-26.0	Peak	Horizontal
	4128.0	37.5	3.8	41.3	74.0	-32.7	Peak	Vertical
	4876.0	36.5	6.0	42.5	74.0	-31.5	Peak	Vertical
*	6083.0	36.0	8.0	44.0	88.0	-44.0	Peak	Vertical
*	9746.5	48.1	16.1	64.2	88.0	-23.8	Peak	Vertical

Note 1: "\*" is not in restricted band, its limit is 20dBc of the fundamental emission level (108.0dBμV/m) or 15.209 which is higher.

Note 2: Measure Level (dBμV/m) = Reading Level (dBμV) + Factor (dB)

Factor (dB) = Cable Loss (dB) + Antenna Factor (dB/m) - Pre\_Amplifier Gain (dB)

Product	Communication Module	Temperature	26°C
Test Engineer	Jone Zhang	Relative Humidity	56%
Test Site	AC1	Test Date	2019/01/17
Test Mode	802.11b	Test Channel	11
Remark:	1. Average measurement was not performed if peak level lower than average limit. 2. Other frequency was 20dB below limit line within 1-18GHz, there is not show in the report.		

Mark	Frequency (MHz)	Reading Level (dBμV)	Factor (dB)	Measure Level (dBμV/m)	Limit (dBμV/m)	Margin (dB)	Detector	Polarization
	4961.0	36.6	6.1	42.7	74.0	-31.3	Peak	Horizontal
	7383.5	38.1	12.6	50.7	74.0	-23.3	Peak	Horizontal
*	8811.5	35.6	13.3	48.9	87.7	-38.8	Peak	Horizontal
*	9848.5	45.3	16.7	62.0	87.7	-25.7	Peak	Horizontal
	4893.0	35.6	6.0	41.6	74.0	-32.4	Peak	Vertical
	7621.5	36.2	12.6	48.8	74.0	-25.2	Peak	Vertical
*	7936.0	36.6	13.5	50.1	87.7	-37.6	Peak	Vertical
*	9848.5	46.8	16.7	63.5	87.7	-24.2	Peak	Vertical

Note 1: "\*" is not in restricted band, its limit is 20dBc of the fundamental emission level (107.7dBμV/m) or 15.209 which is higher.

Note 2: Measure Level (dBμV/m) = Reading Level (dBμV) + Factor (dB)

Factor (dB) = Cable Loss (dB) + Antenna Factor (dB/m) - Pre\_Amplifier Gain (dB)

Product	Communication Module	Temperature	26°C
Test Engineer	Jone Zhang	Relative Humidity	56%
Test Site	AC1	Test Date	2019/01/17
Test Mode	802.11g	Test Channel	01
Remark:	1. Average measurement was not performed if peak level lower than average limit. 2. Other frequency was 20dB below limit line within 1-18GHz, there is not show in the report.		

Mark	Frequency (MHz)	Reading Level (dBμV)	Factor (dB)	Measure Level (dBμV/m)	Limit (dBμV/m)	Margin (dB)	Detector	Polarization
	4264.0	37.6	4.2	41.8	74.0	-32.2	Peak	Horizontal
	4833.5	36.7	5.9	42.6	74.0	-31.4	Peak	Horizontal
*	7230.5	37.8	12.7	50.5	89.2	-38.7	Peak	Horizontal
*	9644.5	39.8	15.5	55.3	89.2	-33.9	Peak	Horizontal
	4799.5	37.7	5.8	43.5	74.0	-30.5	Peak	Vertical
	7434.5	36.0	12.8	48.8	74.0	-25.2	Peak	Vertical
*	8684.0	35.4	13.1	48.5	89.2	-40.7	Peak	Vertical
*	9644.5	44.4	15.5	59.9	89.2	-29.3	Peak	Vertical

Note 1: "\*" is not in restricted band, its limit is 20dBc of the fundamental emission level (109.2dBμV/m) or 15.209 which is higher.

Note 2: Measure Level (dBμV/m) = Reading Level (dBμV) + Factor (dB)

Factor (dB) = Cable Loss (dB) + Antenna Factor (dB/m) - Pre\_Amplifier Gain (dB)

Product	Communication Module	Temperature	26°C
Test Engineer	Jone Zhang	Relative Humidity	56%
Test Site	AC1	Test Date	2019/01/17
Test Mode	802.11g	Test Channel	06
Remark:	1. Average measurement was not performed if peak level lower than average limit. 2. Other frequency was 20dB below limit line within 1-18GHz, there is not show in the report.		

Mark	Frequency (MHz)	Reading Level (dBμV)	Factor (dB)	Measure Level (dBμV/m)	Limit (dBμV/m)	Margin (dB)	Detector	Polarization
	4876.0	37.0	6.0	43.0	74.0	-31.0	Peak	Horizontal
	7307.0	37.7	12.5	50.2	74.0	-23.8	Peak	Horizontal
*	8692.5	35.2	13.0	48.2	88.0	-39.8	Peak	Horizontal
*	9746.5	43.1	16.1	59.2	88.0	-28.8	Peak	Horizontal
	5003.5	37.7	6.3	44.0	74.0	-30.0	Peak	Vertical
	7477.0	35.9	12.9	48.8	74.0	-25.2	Peak	Vertical
*	7953.0	35.5	13.5	49.0	88.0	-39.0	Peak	Vertical
*	9746.5	44.3	16.1	60.4	88.0	-27.6	Peak	Vertical

Note 1: "\*" is not in restricted band, its limit is 20dBc of the fundamental emission level (108.0dBμV/m) or 15.209 which is higher.

Note 2: Measure Level (dBμV/m) = Reading Level (dBμV) + Factor (dB)

Factor (dB) = Cable Loss (dB) + Antenna Factor (dB/m) - Pre\_Amplifier Gain (dB)

Product	Communication Module	Temperature	26°C
Test Engineer	Jone Zhang	Relative Humidity	56%
Test Site	AC1	Test Date	2019/01/17
Test Mode	802.11g	Test Channel	11
Remark:	1. Average measurement was not performed if peak level lower than average limit. 2. Other frequency was 20dB below limit line within 1-18GHz, there is not show in the report.		

Mark	Frequency (MHz)	Reading Level (dBμV)	Factor (dB)	Measure Level (dBμV/m)	Limit (dBμV/m)	Margin (dB)	Detector	Polarization
	4612.5	36.9	5.2	42.1	74.0	-31.9	Peak	Horizontal
	5037.5	36.3	6.5	42.8	74.0	-31.2	Peak	Horizontal
*	7069.0	36.3	11.8	48.1	88.4	-40.3	Peak	Horizontal
*	9848.5	40.6	16.7	57.3	88.4	-31.1	Peak	Horizontal
	4893.0	35.1	6.0	41.1	74.0	-32.9	Peak	Vertical
	7630.0	35.9	12.6	48.5	74.0	-25.5	Peak	Vertical
*	7893.5	35.4	13.4	48.8	88.4	-39.6	Peak	Vertical
*	9848.5	42.6	16.7	59.3	88.4	-29.1	Peak	Vertical

Note 1: "\*" is not in restricted band, its limit is 20dBc of the fundamental emission level (108.4dBμV/m) or 15.209 which is higher.

Note 2: Measure Level (dBμV/m) = Reading Level (dBμV) + Factor (dB)

Factor (dB) = Cable Loss (dB) + Antenna Factor (dB/m) - Pre\_Amplifier Gain (dB)



Product	Communication Module	Temperature	26°C
Test Engineer	Jone Zhang	Relative Humidity	56%
Test Site	AC1	Test Date	2019/01/17
Test Mode	802.11n-HT20	Test Channel	01
Remark:	1. Average measurement was not performed if peak level lower than average limit. 2. Other frequency was 20dB below limit line within 1-18GHz, there is not show in the report.		

Mark	Frequency (MHz)	Reading Level (dBμV)	Factor (dB)	Measure Level (dBμV/m)	Limit (dBμV/m)	Margin (dB)	Detector	Polarization
	4876.0	36.3	6.0	42.3	74.0	-31.7	Peak	Horizontal
	7562.0	36.6	12.9	49.5	74.0	-24.5	Peak	Horizontal
*	8794.5	35.3	13.3	48.6	88.6	-40.0	Peak	Horizontal
*	9627.5	39.2	15.4	54.6	88.6	-34.0	Peak	Horizontal
	5003.5	38.0	6.3	44.3	74.0	-29.7	Peak	Vertical
	7468.5	35.5	12.9	48.4	74.0	-25.6	Peak	Vertical
*	7953.0	34.5	13.5	48.0	88.6	-40.6	Peak	Vertical
*	9653.0	40.2	15.5	55.7	88.6	-32.9	Peak	Vertical

Note 1: "\*" is not in restricted band, its limit is 20dBc of the fundamental emission level (108.6dBμV/m) or 15.209 which is higher.

Note 2: Measure Level (dBμV/m) = Reading Level (dBμV) + Factor (dB)

Factor (dB) = Cable Loss (dB) + Antenna Factor (dB/m) - Pre\_Amplifier Gain (dB)

Product	Communication Module	Temperature	26°C
Test Engineer	Jone Zhang	Relative Humidity	56%
Test Site	AC1	Test Date	2019/01/17
Test Mode:	802.11n-HT20	Test Channel:	06
Remark:	1. Average measurement was not performed if peak level lower than average limit. 2. Other frequency was 20dB below limit line within 1-18GHz, there is not show in the report.		

Mark	Frequency (MHz)	Reading Level (dBμV)	Factor (dB)	Measure Level (dBμV/m)	Limit (dBμV/m)	Margin (dB)	Detector	Polarization
	4833.5	36.8	5.9	42.7	74.0	-31.3	Peak	Horizontal
	7451.5	35.6	12.9	48.5	74.0	-25.5	Peak	Horizontal
*	7876.5	36.1	13.3	49.4	88.0	-38.6	Peak	Horizontal
*	9746.5	41.1	16.1	57.2	88.0	-30.8	Peak	Horizontal
	5003.5	37.2	6.3	43.5	74.0	-30.5	Peak	Vertical
	8182.5	37.6	13.2	50.8	74.0	-23.2	Peak	Vertical
*	8709.5	35.3	13.0	48.3	88.0	-39.7	Peak	Vertical
*	9746.5	44.7	16.1	60.8	88.0	-27.2	Peak	Vertical

Note 1: "\*" is not in restricted band, its limit is 20dBc of the fundamental emission level (108.0dBμV/m) or 15.209 which is higher.

Note 2: Measure Level (dBμV/m) = Reading Level (dBμV) + Factor (dB)

Factor (dB) = Cable Loss (dB) + Antenna Factor (dB/m) - Pre\_Amplifier Gain (dB)

Product	Communication Module	Temperature	26°C
Test Engineer	Jone Zhang	Relative Humidity	56%
Test Site	AC1	Test Date	2019/01/17
Test Mode:	802.11n-HT20	Test Channel:	11
Remark:	1. Average measurement was not performed if peak level lower than average limit. 2. Other frequency was 20dB below limit line within 1-18GHz, there is not show in the report.		

Mark	Frequency (MHz)	Reading Level (dBμV)	Factor (dB)	Measure Level (dBμV/m)	Limit (dBμV/m)	Margin (dB)	Detector	Polarization
	4340.5	38.6	4.3	42.9	74.0	-31.1	Peak	Horizontal
	4935.5	36.0	6.1	42.1	74.0	-31.9	Peak	Horizontal
*	7128.5	35.5	12.3	47.8	87.9	-40.1	Peak	Horizontal
*	9848.5	37.8	16.7	54.5	87.9	-33.4	Peak	Horizontal
	5003.5	36.5	6.3	42.8	74.0	-31.2	Peak	Vertical
	7468.5	36.7	12.9	49.6	74.0	-24.4	Peak	Vertical
*	7927.5	35.3	13.5	48.8	87.9	-39.1	Peak	Vertical
*	9865.5	42.8	16.7	59.5	87.9	-28.4	Peak	Vertical

Note 1: "\*" is not in restricted band, its limit is 20dBc of the fundamental emission level (107.9dBμV/m) or 15.209 which is higher.

Note 2: Measure Level (dBμV/m) = Reading Level (dBμV) + Factor (dB)

Factor (dB) = Cable Loss (dB) + Antenna Factor (dB/m) - Pre\_Amplifier Gain (dB)

**The Worst Case of Radiated Emission below 1GHz:**

Site: AC1	Time: 2019/03/06 - 01:12
Limit: FCC_Part15.209_RSE(3m)	Engineer: Messiah Li
Probe: VULB 9168 _20-2000MHz	Polarity: Horizontal
EUT: Communication Module	Power: DC 3.3V
<b>Test Mode: Worst case</b>	

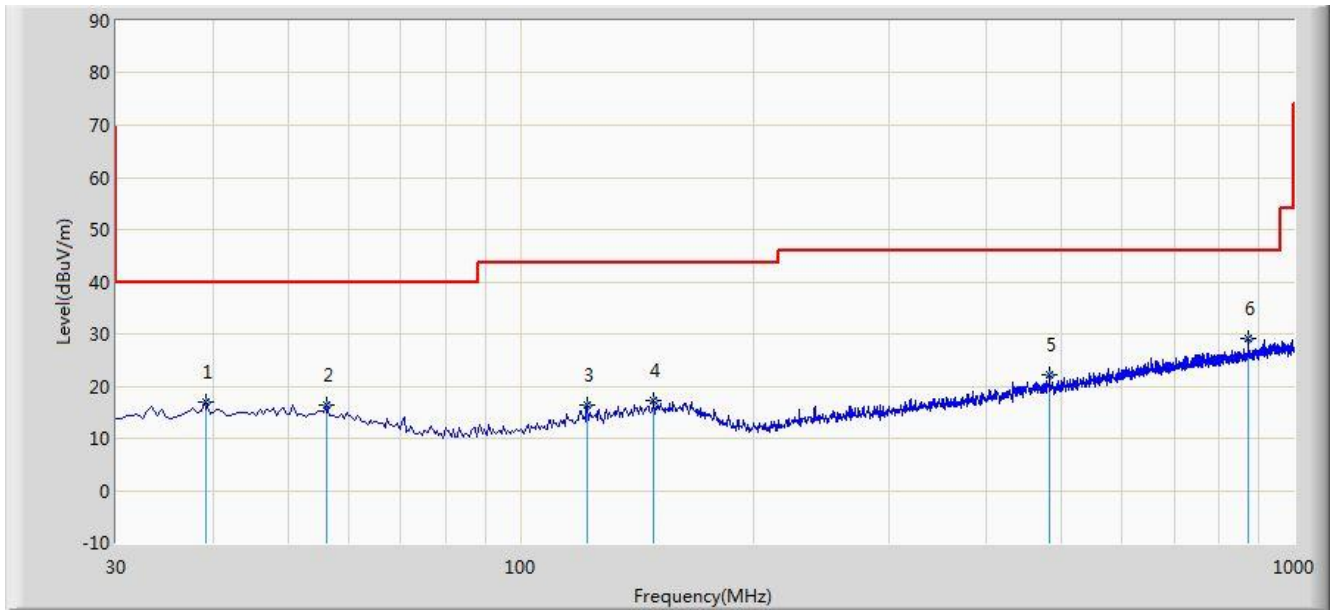

No	Flag	Mark	Frequency (MHz)	Measure Level (dBuV/m)	Reading Level (dBuV)	Over Limit (dB)	Limit (dBuV/m)	Factor (dB)	Type
1			39.215	16.839	2.293	-23.161	40.000	14.546	QP
2			56.190	16.473	2.733	-23.527	40.000	13.740	QP
3			122.150	16.347	2.977	-27.153	43.500	13.369	QP
4			148.825	17.186	1.986	-26.314	43.500	15.200	QP
5			483.475	22.050	3.720	-23.950	46.000	18.330	QP
6		*	871.960	28.990	4.969	-17.010	46.000	24.021	QP

Note 1: Measure Level (dB $\mu$ V/m) = Reading Level (dB $\mu$ V) + Factor (dB)

Factor (dB) = Cable Loss (dB) + Antenna Factor (dB/m)

Note 2: The test trace is same as the ambient noise and the amplitude of the emissions are attenuated more than 20dB below the permissible (the test frequency range: 9kHz ~ 30MHz, 18GHz ~ 25GHz), therefore no data appear in the report.

Site: AC1	Time: 2019/03/06 - 01:13
Limit: FCC_Part15.209_RSE(3m)	Engineer: Messiah Li
Probe: VULB 9168 _20-2000MHz	Polarity: Vertical
EUT: Communication Module	Power: DC 3.3V
<b>Test Mode: Worst case</b>	

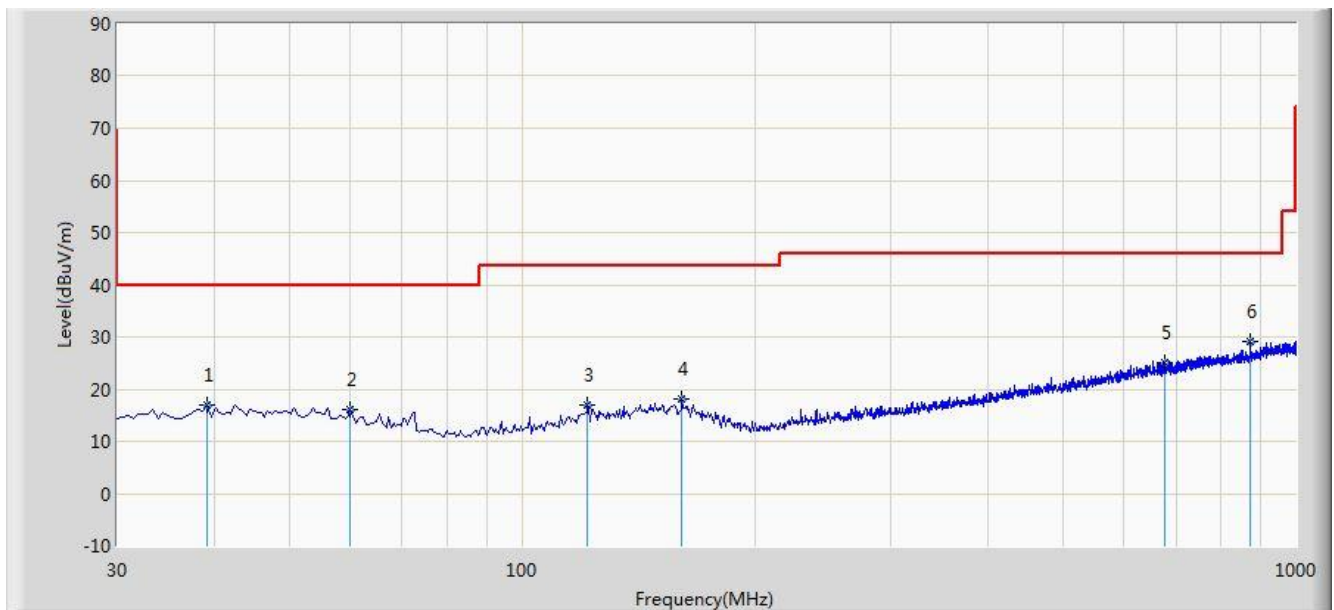

No	Flag	Mark	Frequency (MHz)	Measure Level (dBuV/m)	Reading Level (dBuV)	Over Limit (dB)	Limit (dBuV/m)	Factor (dB)	Type
1			39.215	16.839	2.293	-23.161	40.000	14.546	QP
2			60.070	16.152	2.737	-23.848	40.000	13.415	QP
3			121.665	17.054	3.712	-26.446	43.500	13.342	QP
4			160.950	18.064	2.843	-25.436	43.500	15.220	QP
5			678.445	24.965	3.127	-21.035	46.000	21.838	QP
6		*	871.960	28.990	4.969	-17.010	46.000	24.021	QP

Note 1: Measure Level (dB $\mu$ V/m) = Reading Level (dB $\mu$ V) + Factor (dB)

Factor (dB) = Cable Loss (dB) + Antenna Factor (dB/m)

Note 2: The test trace is same as the ambient noise and the amplitude of the emissions are attenuated more than 20dB below the permissible (the test frequency range: 9kHz ~ 30MHz, 18GHz ~ 25GHz), therefore no data appear in the report.

## 6.7. Radiated Restricted Band Edge Measurement

### 6.7.1. Test Limit

#### **For 15.205 requirement:**

Radiated emissions which fall in the restricted bands, as defined in Section 15.205(a) of FCC part 15, must also comply with the radiated emission limits specified in Section 15.209(a).

Frequency (MHz)	Frequency (MHz)	Frequency (MHz)	Frequency (GHz)
0.090 - 0.110	16.42 - 16.423	399.9 - 410	4.5 - 5.15
<sup>1</sup> 0.495 - 0.505	16.69475 - 16.69525	608 - 614	5.35 - 5.46
2.1735 - 2.1905	16.80425 - 16.80475	960 - 1240	7.25 - 7.75
4.125 - 4.128	25.5 - 25.67	1300 - 1427	8.025 - 8.5
4.17725 - 4.17775	37.5 - 38.25	1435 - 1626.5	9.0 - 9.2
4.20725 - 4.20775	73 - 74.6	1645.5 - 1646.5	9.3 - 9.5
6.215 - 6.218	74.8 - 75.2	1660 - 1710	10.6 - 12.7
6.26775 - 6.26825	108 - 121.94	1718.8 - 1722.2	13.25 - 13.4
6.31175 - 6.31225	123 - 138	2200 - 2300	14.47 - 14.5
8.291 - 8.294	149.9 - 150.05	2310 - 2390	15.35 - 16.2
8.362 - 8.366	156.52475 - 156.525	2483.5 - 2500	17.7 - 21.4
8.37625 - 8.38675	156.7 - 156.9	2690 - 2900	22.01 - 23.12
8.41425 - 8.41475	162.0125 - 167.17	3260 - 3267	23.6 - 24.0
12.29 - 12.293	167.72 - 173.2	3332 - 3339	31.2 - 31.8
12.51975 - 12.52025	240 - 285	3345.8 - 3358	36.43 - 36.5
12.57675 - 12.57725	322 - 335.4	3600 - 4400	( <sup>2</sup> )
13.36 - 13.41	--	--	--

All out of band emissions appearing in a restricted band as specified in Section 15.205 of the Title 47CFR must not exceed the limits shown in Table per Section 15.209.

<b>FCC Part 15 Subpart C Paragraph 15.209</b>		
Frequency [MHz]	Field Strength [uV/m]	Measured Distance [Meters]
0.009 - 0.490	2400/F (kHz)	300
0.490 - 1.705	24000/F (kHz)	30
1.705 - 30	30	30
30 - 88	100	3
88 - 216	150	3
216 - 960	200	3
Above 960	500	3

**For RSS-Gen Section 8.10 requirement:**

Radiated emissions which fall in the restricted bands, as defined in Section 8.10 of RSS-Gen, must also comply with the radiated emission limits specified in Section 8.9.

Frequency (MHz)	Frequency (MHz)	Frequency (GHz)
0.090 - 0.110	149.9 - 150.5	9.0 - 9.2
0.495 - 0.505	156.52475 - 156.525225	9.3 - 9.5
2.1735 - 2.1905	156.7 - 156.9	10.6 - 12.7
3.020 - 3.026	162.0125 - 167.17	13.25 - 13.4
4.125 - 4.128	167.72 - 173.2	14.47 - 14.5
4.17725 - 4.17775	240 - 285	15.35 - 16.2
4.20725 - 4.20775	322 - 335.4	17.7 - 21.4
5.677 - 5.683	399.9 - 410	22.01 - 23.12
6.215 - 6.218	608 - 614	23.6 - 24.0
6.26775 - 6.26825	960 - 1427	31.2 - 31.8
6.31175 - 6.31225	1435 - 1626.5	36.43 - 36.5
8.291 - 8.294	1645.5 - 1646.5	Above 38.6
8.362 - 8.366	1660 - 1710	--
8.37625 - 8.38675	1718.8 - 1722.2	
8.41425 - 8.41475	2200 - 2300	
12.29 - 12.293	2310 - 2390	
12.51975 - 12.52025	2483.5 - 2500	
12.57675 - 12.57725	2655 - 2900	
13.36 - 13.41	3260 - 3267	
16.42 - 16.423	3332 - 3339	
16.69475 - 16.69525	334.5 - 3358	
16.80425 - 16.80475	3500 - 4400	
25.5 - 25.67	4500 - 5150	
37.5 - 38.25	5350 - 5460	
73 - 74.6	7250 - 7750	
74.8 - 75.2	8025 - 8500	
108 - 138	--	



All out of band emissions appearing in a restricted band as specified in Section 8.10 of the RSS-Gen must not exceed the limits shown in Table per Section 8.9.

RSS-Gen Section 8.9			
Frequency [MHz]	Magnetic field strength (H-Field) [uA/m]	Field Strength [uV/m]	Measured Distance [Meters]
0.009 - 0.490	6.37/F(F in kHz)	--	300
0.490 - 1.705	63.7/F(F in kHz)	--	30
1.705 - 30	0.08	--	30
30 - 88	--	100	3
88 - 216	--	150	3
216 - 960	--	200	3
Above 960	--	500	3

**6.7.2. Test Procedure Used**

ANSI C63.10 Section 6.3 (General Requirements)

ANSI C63.10 Section 6.6 (Standard test method above 1GHz)

**6.7.3. Test Setting**

**Peak Field Strength Measurements**

1. Analyzer center frequency was set to the frequency of the radiated spurious emission of interest
2. RBW = 1MHz
3. VBW = 3MHz
4. Detector = peak
5. Sweep time = auto couple
6. Trace mode = max hold
7. Trace was allowed to stabilize

### Average Measurements above 1GHz (Method VB)

1. Analyzer center frequency was set to the frequency of the radiated spurious emission of interest
2. RBW = 1MHz
3. VBW; If the EUT is configured to transmit with duty cycle  $\geq 98\%$ , set VBW = 10 Hz.  
If the EUT duty cycle is  $< 98\%$ , set VBW  $\geq 1/T$ . T is the minimum transmission duration.
4. Detector = Peak
5. Sweep time = auto
6. Trace mode = max hold
7. Trace was allowed to stabilize

#### 6.7.4. Test Setup

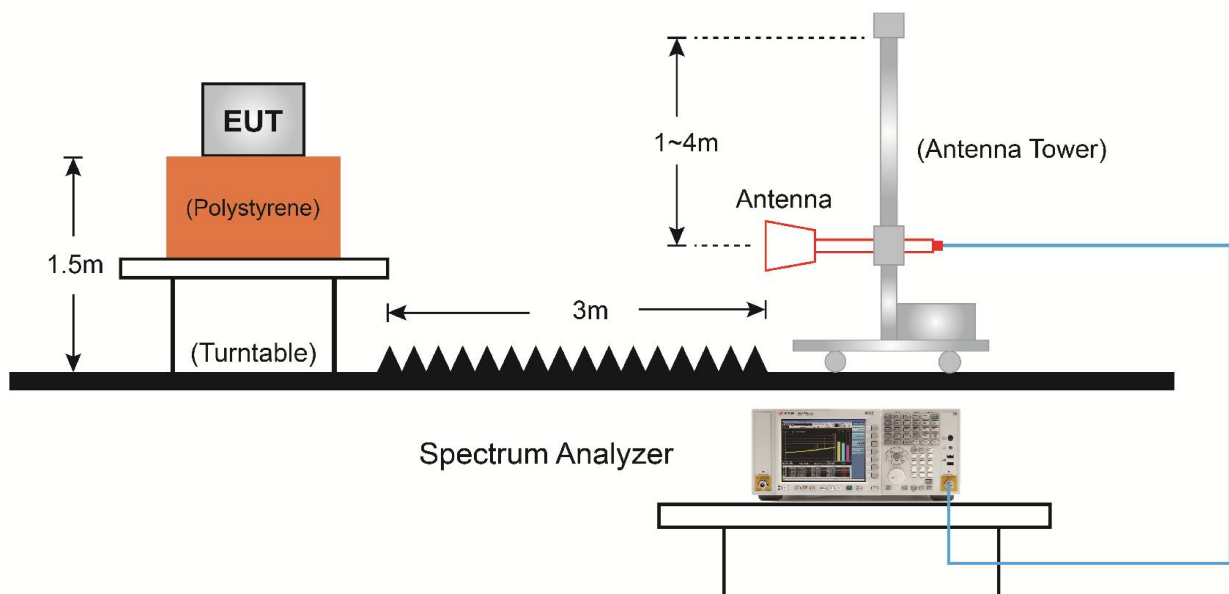

### 6.7.5. Test Result

Site: AC1	Time: 2019/01/16 - 04:40
Limit: FCC_Part15.209_RE(3m)	Engineer: Jone Zhang
Probe: BBHA9120D_1-18GHz	Polarity: Horizontal
EUT: Communication Module	Power: DC 3.3V
Test Mode: Transmit by 802.11b at Channel 2412MHz	

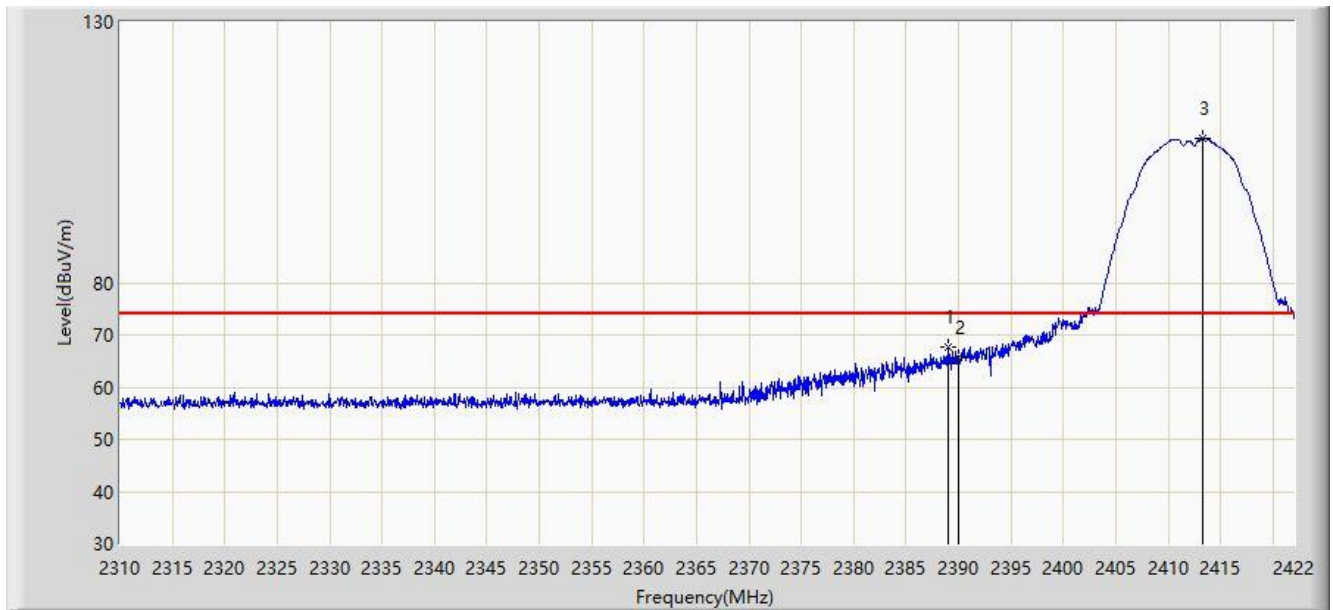

No	Flag	Mark	Frequency (MHz)	Measure Level (dBuV/m)	Reading Level (dBuV)	Over Limit (dB)	Limit (dBuV/m)	Factor (dB)	Type
1			2388.960	67.633	35.305	-6.367	74.000	32.328	PK
2			2390.000	65.645	33.318	-8.355	74.000	32.327	PK
3		*	2413.320	107.687	75.403	N/A	N/A	32.285	PK

Note: Measure Level (dB $\mu$ V/m) = Reading Level (dB $\mu$ V) + Factor (dB)

Factor (dB) = Cable Loss (dB) + Antenna Factor (dB/m)

Site: AC1	Time: 2019/01/16 - 04:46
Limit: FCC_Part15.209_RE(3m)	Engineer: Jone Zhang
Probe: BBHA9120D_1-18GHz	Polarity: Horizontal
EUT: Communication Module	Power: DC 3.3V
Test Mode: Transmit by 802.11b at Channel 2412MHz	

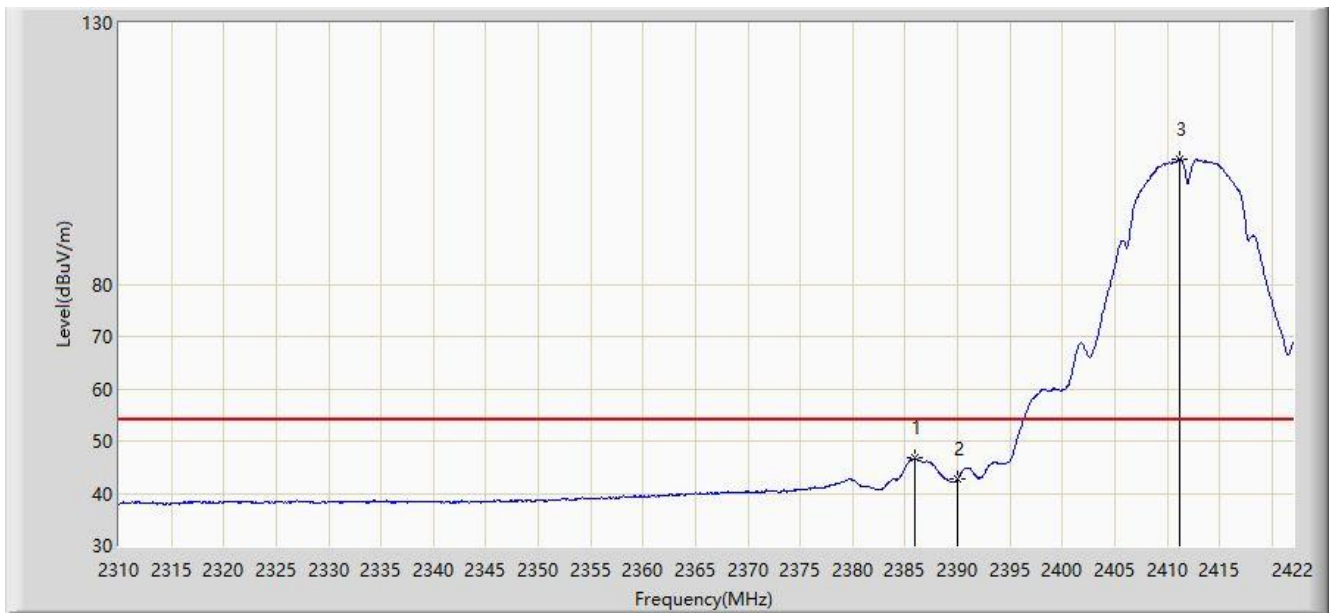

No	Flag	Mark	Frequency (MHz)	Measure Level (dBuV/m)	Reading Level (dBuV)	Over Limit (dB)	Limit (dBuV/m)	Factor (dB)	Type
1			2385.880	46.687	14.355	-7.313	54.000	32.333	AV
2			2390.000	42.793	10.466	-11.207	54.000	32.327	AV
3		*	2411.192	103.959	71.674	N/A	N/A	32.285	AV

Note: Measure Level (dB $\mu$ V/m) = Reading Level (dB $\mu$ V) + Factor (dB)

Factor (dB) = Cable Loss (dB) + Antenna Factor (dB/m)

Site: AC1	Time: 2019/01/16 - 04:48
Limit: FCC_Part15.209_RE(3m)	Engineer: Jone Zhang
Probe: BBHA9120D_1-18GHz	Polarity: Vertical
EUT: Communication Module	Power: DC 3.3V
Test Mode: Transmit by 802.11b at Channel 2412MHz	

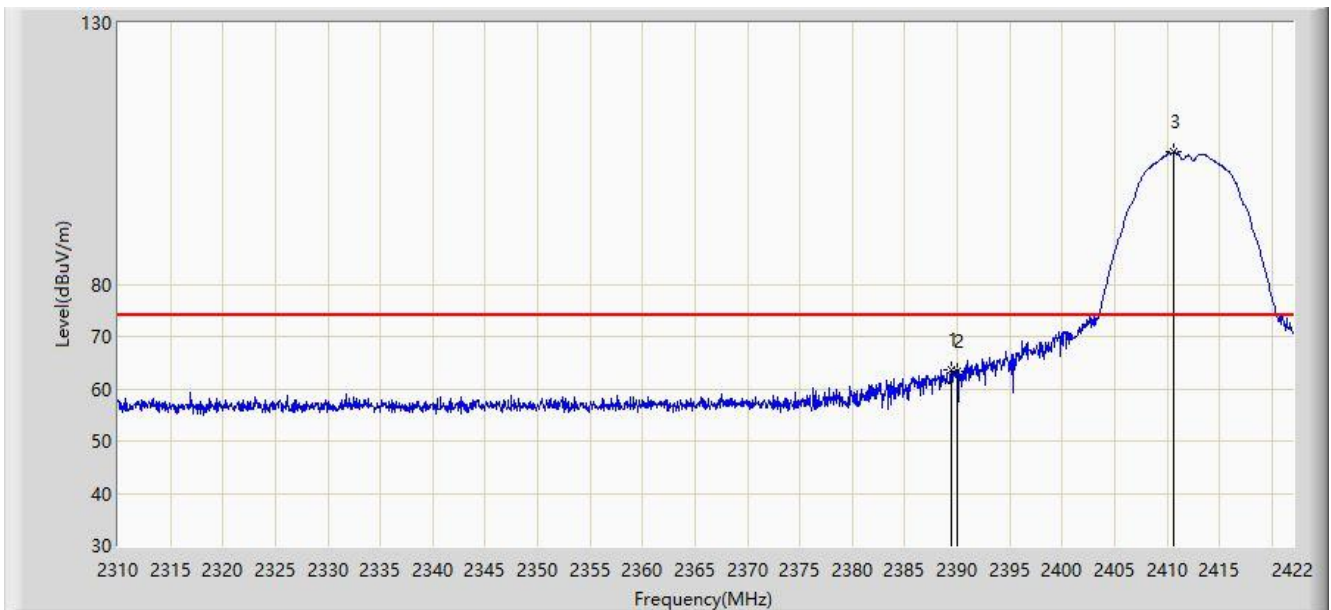

No	Flag	Mark	Frequency (MHz)	Measure Level (dBuV/m)	Reading Level (dBuV)	Over Limit (dB)	Limit (dBuV/m)	Factor (dB)	Type
1			2389.408	63.643	31.315	-10.357	74.000	32.327	PK
2			2390.000	63.366	31.039	-10.634	74.000	32.327	PK
3		*	2410.576	105.221	72.935	N/A	N/A	32.286	PK

Note: Measure Level (dB $\mu$ V/m) = Reading Level (dB $\mu$ V) + Factor (dB)

Factor (dB) = Cable Loss (dB) + Antenna Factor (dB/m)

Site: AC1	Time: 2019/01/16 - 04:50
Limit: FCC_Part15.209_RE(3m)	Engineer: Jone Zhang
Probe: BBHA9120D_1-18GHz	Polarity: Vertical
EUT: Communication Module	Power: DC 3.3V
Test Mode: Transmit by 802.11b at Channel 2412MHz	

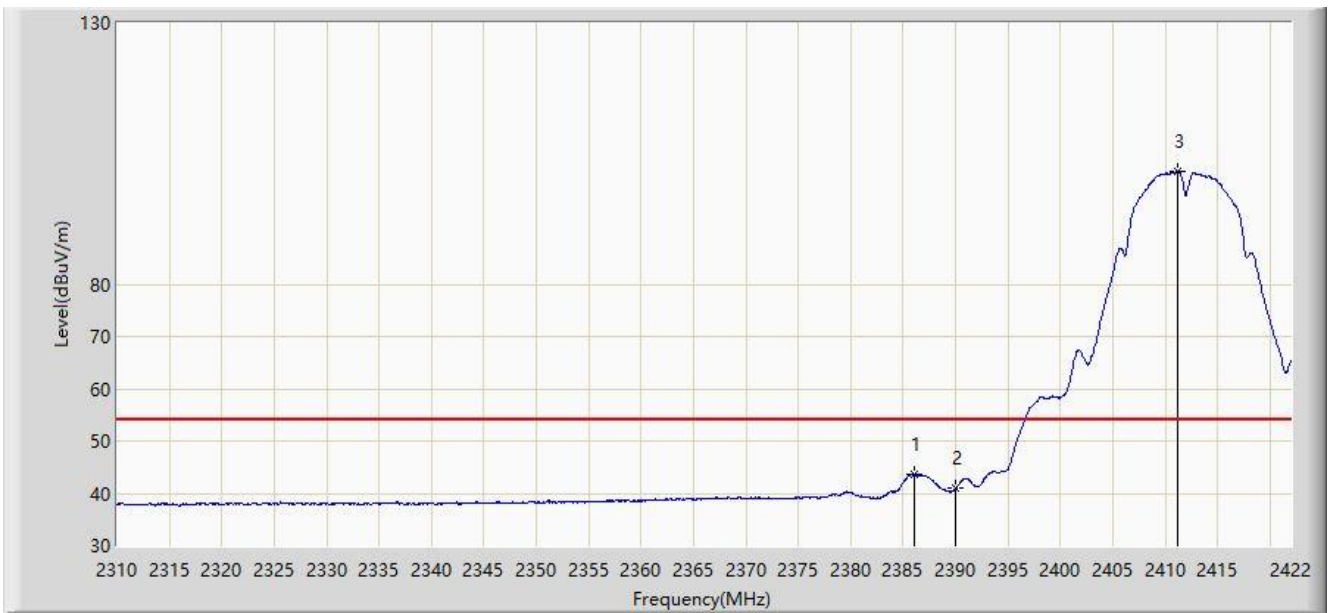

No	Flag	Mark	Frequency (MHz)	Measure Level (dBuV/m)	Reading Level (dBuV)	Over Limit (dB)	Limit (dBuV/m)	Factor (dB)	Type
1			2386.048	43.719	11.387	-10.281	54.000	32.332	AV
2			2390.000	40.881	8.554	-13.119	54.000	32.327	AV
3		*	2411.192	101.735	69.450	N/A	N/A	32.285	AV

Note: Measure Level (dB $\mu$ V/m) = Reading Level (dB $\mu$ V) + Factor (dB)

Factor (dB) = Cable Loss (dB) + Antenna Factor (dB/m)

Site: AC1	Time: 2019/01/16 - 04:52
Limit: FCC_Part15.209_RE(3m)	Engineer: Jone Zhang
Probe: BBHA9120D_1-18GHz	Polarity: Horizontal
EUT: Communication Module	Power: DC 3.3V
Test Mode: Transmit by 802.11b at Channel 2462MHz	

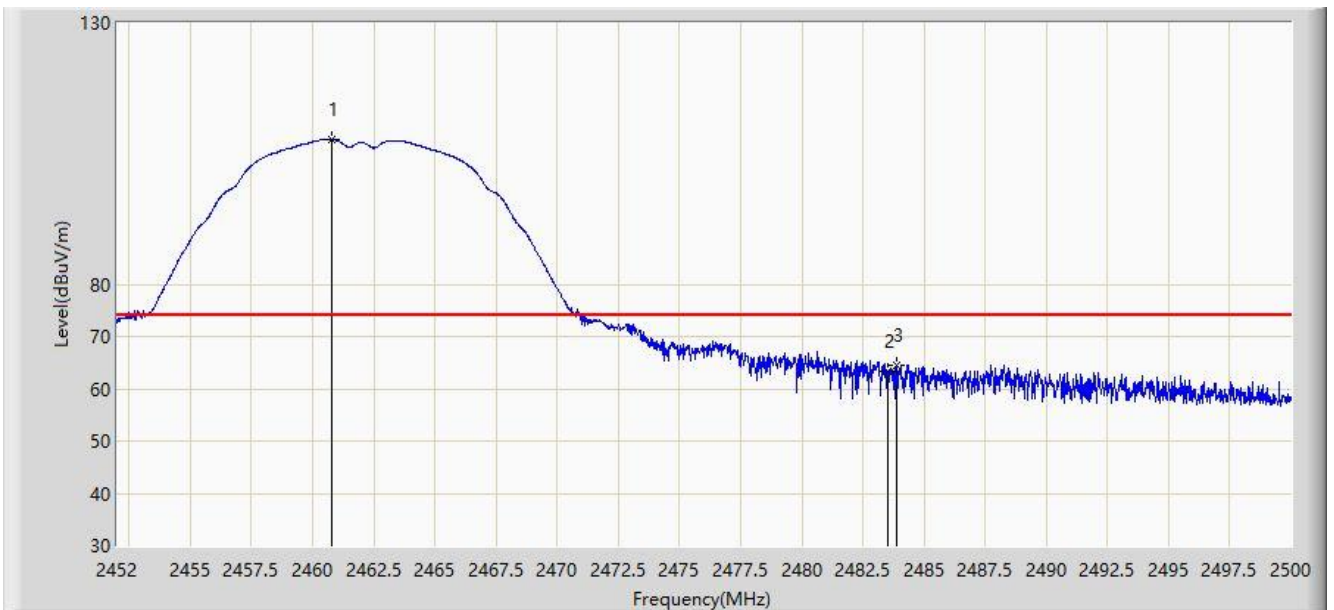

No	Flag	Mark	Frequency (MHz)	Measure Level (dBuV/m)	Reading Level (dBuV)	Over Limit (dB)	Limit (dBuV/m)	Factor (dB)	Type
1		*	2460.760	107.657	75.379	N/A	N/A	32.278	PK
2			2483.500	63.341	31.002	-10.659	74.000	32.340	PK
3			2483.896	64.537	32.196	-9.463	74.000	32.340	PK

Note: Measure Level (dB $\mu$ V/m) = Reading Level (dB $\mu$ V) + Factor (dB)

Factor (dB) = Cable Loss (dB) + Antenna Factor (dB/m)

Site: AC1	Time: 2019/01/16 - 04:56
Limit: FCC_Part15.209_RE(3m)	Engineer: Jone Zhang
Probe: BBHA9120D_1-18GHz	Polarity: Horizontal
EUT: Communication Module	Power: DC 3.3V
Test Mode: Transmit by 802.11b at Channel 2462MHz	



No	Flag	Mark	Frequency (MHz)	Measure Level (dBuV/m)	Reading Level (dBuV)	Over Limit (dB)	Limit (dBuV/m)	Factor (dB)	Type
1		*	2461.216	104.177	71.898	N/A	N/A	32.279	AV
2			2483.500	45.701	13.362	-8.299	54.000	32.340	AV
3			2487.952	46.621	14.264	-7.379	54.000	32.357	AV

Note: Measure Level (dB $\mu$ V/m) = Reading Level (dB $\mu$ V) + Factor (dB)

Factor (dB) = Cable Loss (dB) + Antenna Factor (dB/m)



Site: AC1	Time: 2019/01/16 - 04:57
Limit: FCC_Part15.209_RE(3m)	Engineer: Jone Zhang
Probe: BBHA9120D_1-18GHz	Polarity: Vertical
EUT: Communication Module	Power: DC 3.3V
Test Mode: Transmit by 802.11b at Channel 2462MHz	

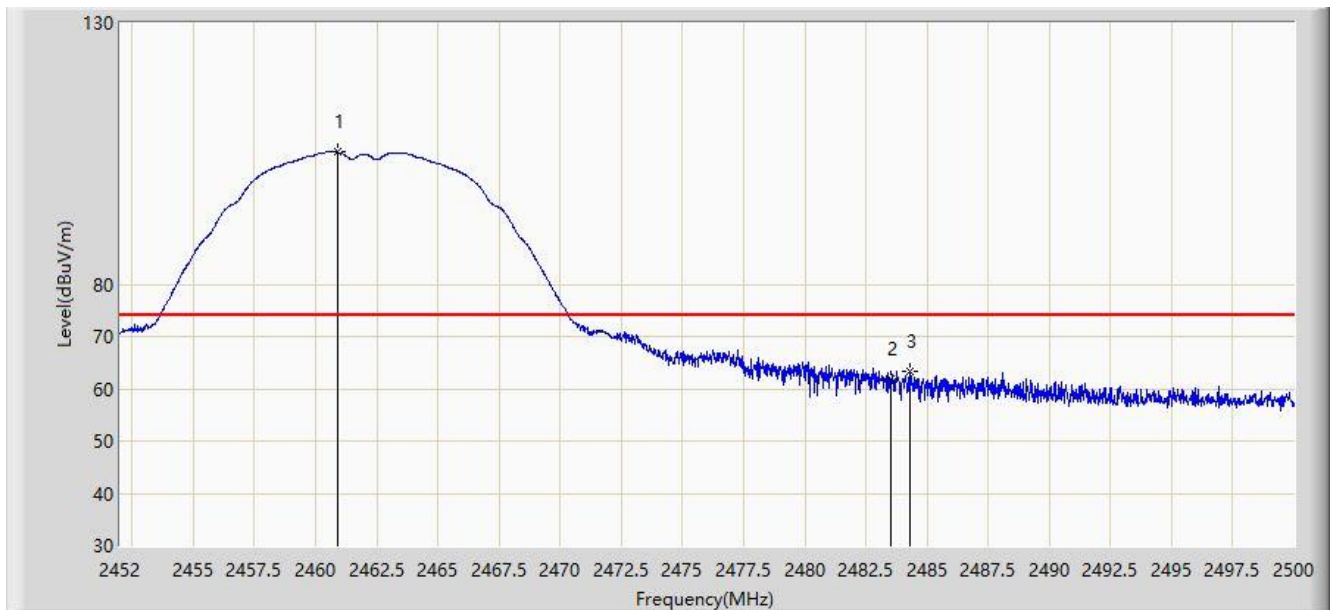

No	Flag	Mark	Frequency (MHz)	Measure Level (dBuV/m)	Reading Level (dBuV)	Over Limit (dB)	Limit (dBuV/m)	Factor (dB)	Type
1		*	2460.880	105.263	72.985	N/A	N/A	32.278	PK
2			2483.500	61.855	29.516	-12.145	74.000	32.340	PK
3			2484.328	63.458	31.116	-10.542	74.000	32.342	PK

Note: Measure Level (dB $\mu$ V/m) = Reading Level (dB $\mu$ V) + Factor (dB)

Factor (dB) = Cable Loss (dB) + Antenna Factor (dB/m)

Site: AC1	Time: 2019/01/16 - 05:00
Limit: FCC_Part15.209_RE(3m)	Engineer: Jone Zhang
Probe: BBHA9120D_1-18GHz	Polarity: Vertical
EUT: Communication Module	Power: DC 3.3V
Test Mode: Transmit by 802.11b at Channel 2462MHz	

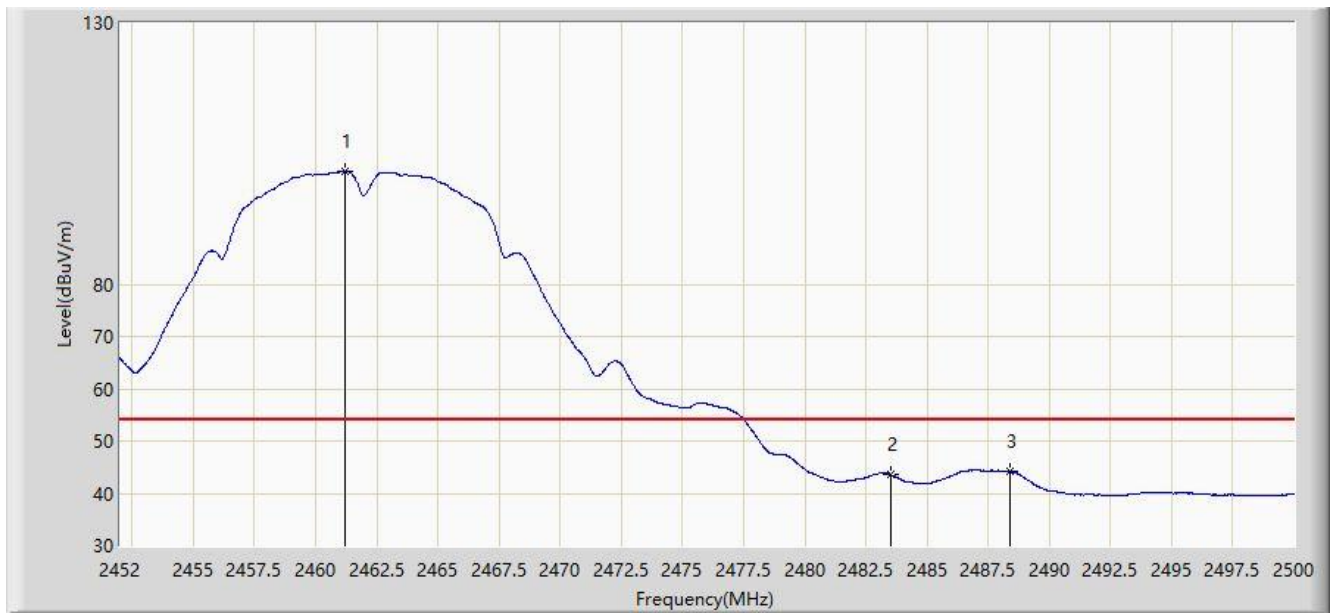

No	Flag	Mark	Frequency (MHz)	Measure Level (dBuV/m)	Reading Level (dBuV)	Over Limit (dB)	Limit (dBuV/m)	Factor (dB)	Type
1		*	2461.192	101.733	69.454	N/A	N/A	32.279	AV
2			2483.500	43.616	11.277	-10.384	54.000	32.340	AV
3			2488.408	44.134	11.776	-9.866	54.000	32.358	AV

Note: Measure Level (dB $\mu$ V/m) = Reading Level (dB $\mu$ V) + Factor (dB)

Factor (dB) = Cable Loss (dB) + Antenna Factor (dB/m)

Site: AC1	Time: 2019/01/16 - 05:02
Limit: FCC_Part15.209_RE(3m)	Engineer: Jone Zhang
Probe: BBHA9120D_1-18GHz	Polarity: Horizontal
EUT: Communication Module	Power: DC 3.3V
Test Mode: Transmit by 802.11g at Channel 2412MHz	

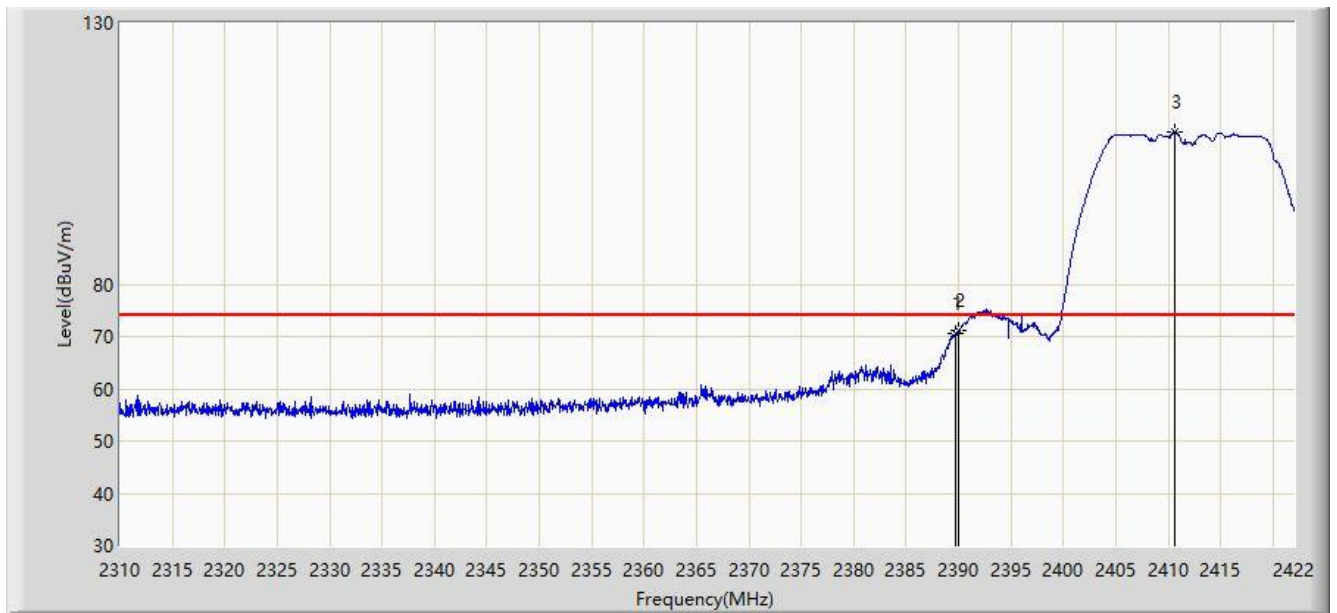

No	Flag	Mark	Frequency (MHz)	Measure Level (dBuV/m)	Reading Level (dBuV)	Over Limit (dB)	Limit (dBuV/m)	Factor (dB)	Type
1			2389.688	70.545	38.218	-3.455	74.000	32.328	PK
2			2390.000	71.072	38.745	-2.928	74.000	32.327	PK
3		*	2410.632	109.158	76.872	N/A	N/A	32.286	PK

Note: Measure Level (dB $\mu$ V/m) = Reading Level (dB $\mu$ V) + Factor (dB)

Factor (dB) = Cable Loss (dB) + Antenna Factor (dB/m)

Site: AC1	Time: 2019/01/16 - 05:05
Limit: FCC_Part15.209_RE(3m)	Engineer: Jone Zhang
Probe: BBHA9120D_1-18GHz	Polarity: Horizontal
EUT: Communication Module	Power: DC 3.3V
Test Mode: Transmit by 802.11g at Channel 2412MHz	

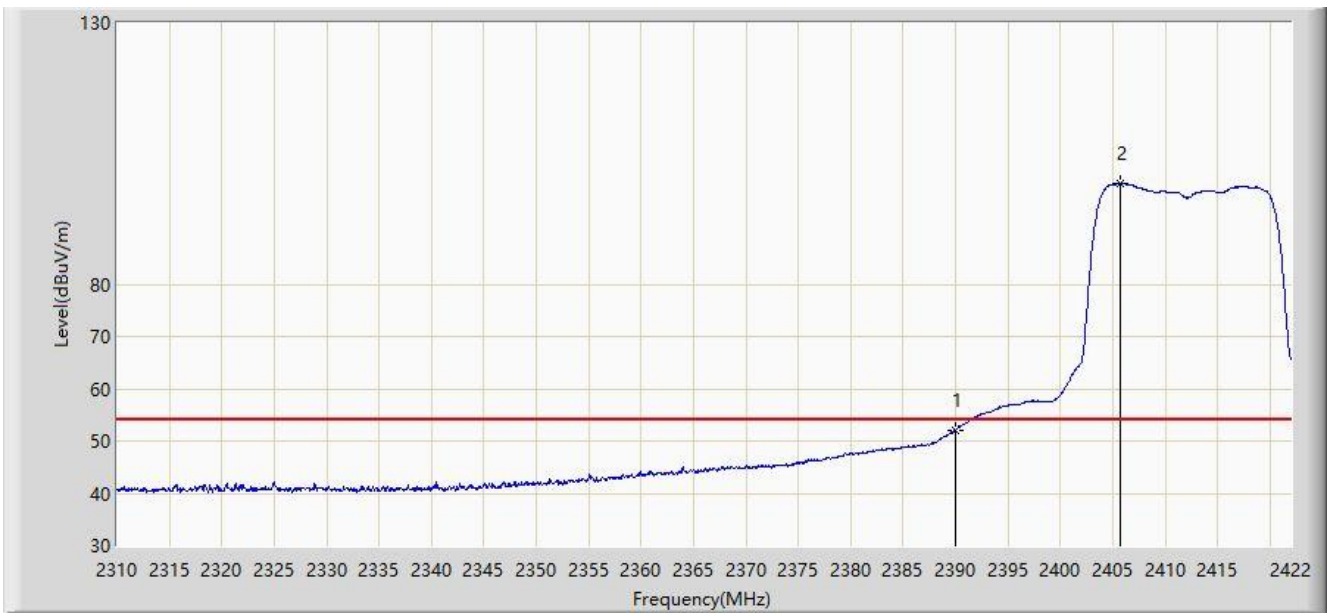

No	Flag	Mark	Frequency (MHz)	Measure Level (dBuV/m)	Reading Level (dBuV)	Over Limit (dB)	Limit (dBuV/m)	Factor (dB)	Type
1			2390.000	52.092	19.765	-1.908	54.000	32.327	AV
2		*	2405.760	99.143	66.847	N/A	N/A	32.296	AV

Note: Measure Level (dBuV/m) = Reading Level (dBuV) + Factor (dB)

Factor (dB) = Cable Loss (dB) + Antenna Factor (dB/m)

Site: AC1	Time: 2019/01/16 - 05:07
Limit: FCC_Part15.209_RE(3m)	Engineer: Jone Zhang
Probe: BBHA9120D_1-18GHz	Polarity: Vertical
EUT: Communication Module	Power: DC 3.3V
Test Mode: Transmit by 802.11g at Channel 2412MHz	

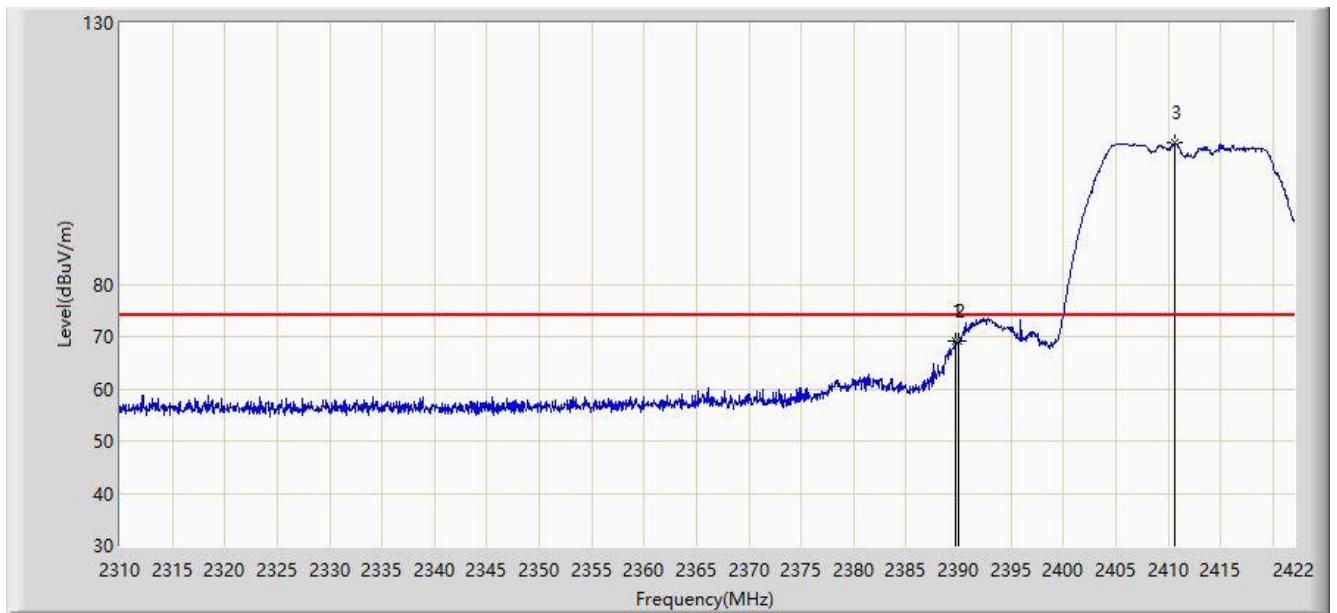

No	Flag	Mark	Frequency (MHz)	Measure Level (dBuV/m)	Reading Level (dBuV)	Over Limit (dB)	Limit (dBuV/m)	Factor (dB)	Type
1			2389.744	69.004	36.677	-4.996	74.000	32.327	PK
2			2390.000	69.225	36.898	-4.775	74.000	32.327	PK
3		*	2410.632	107.108	74.822	N/A	N/A	32.286	PK

Note: Measure Level (dB $\mu$ V/m) = Reading Level (dB $\mu$ V) + Factor (dB)

Factor (dB) = Cable Loss (dB) + Antenna Factor (dB/m)

Site: AC1	Time: 2019/01/16 - 05:09
Limit: FCC_Part15.209_RE(3m)	Engineer: Jone Zhang
Probe: BBHA9120D_1-18GHz	Polarity: Vertical
EUT: Communication Module	Power: DC 3.3V
Test Mode: Transmit by 802.11g at Channel 2412MHz	

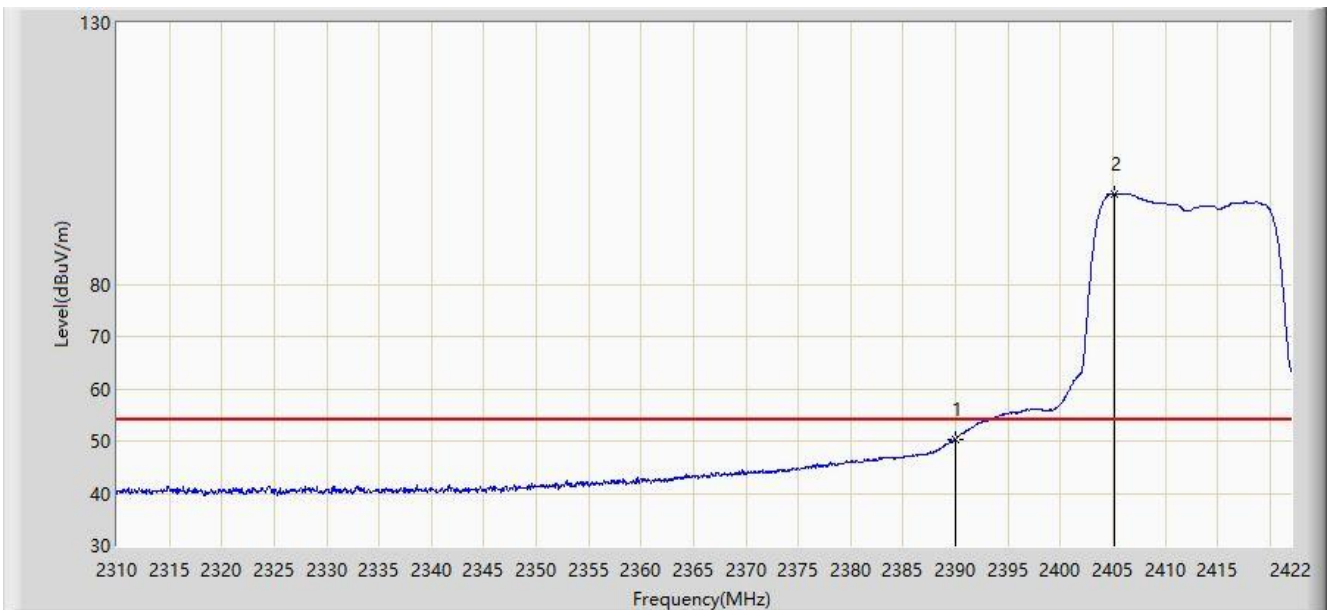

No	Flag	Mark	Frequency (MHz)	Measure Level (dBuV/m)	Reading Level (dBuV)	Over Limit (dB)	Limit (dBuV/m)	Factor (dB)	Type
1			2390.000	50.384	18.057	-3.616	54.000	32.327	AV
2		*	2405.200	97.255	64.957	N/A	N/A	32.298	AV

Note: Measure Level (dB $\mu$ V/m) = Reading Level (dB $\mu$ V) + Factor (dB)

Factor (dB) = Cable Loss (dB) + Antenna Factor (dB/m)

Site: AC1	Time: 2019/01/16 - 05:18
Limit: FCC_Part15.209_RE(3m)	Engineer: Jone Zhang
Probe: BBHA9120D_1-18GHz	Polarity: Horizontal
EUT: Communication Module	Power: DC 3.3V
Test Mode: Transmit by 802.11g at Channel 2462MHz	

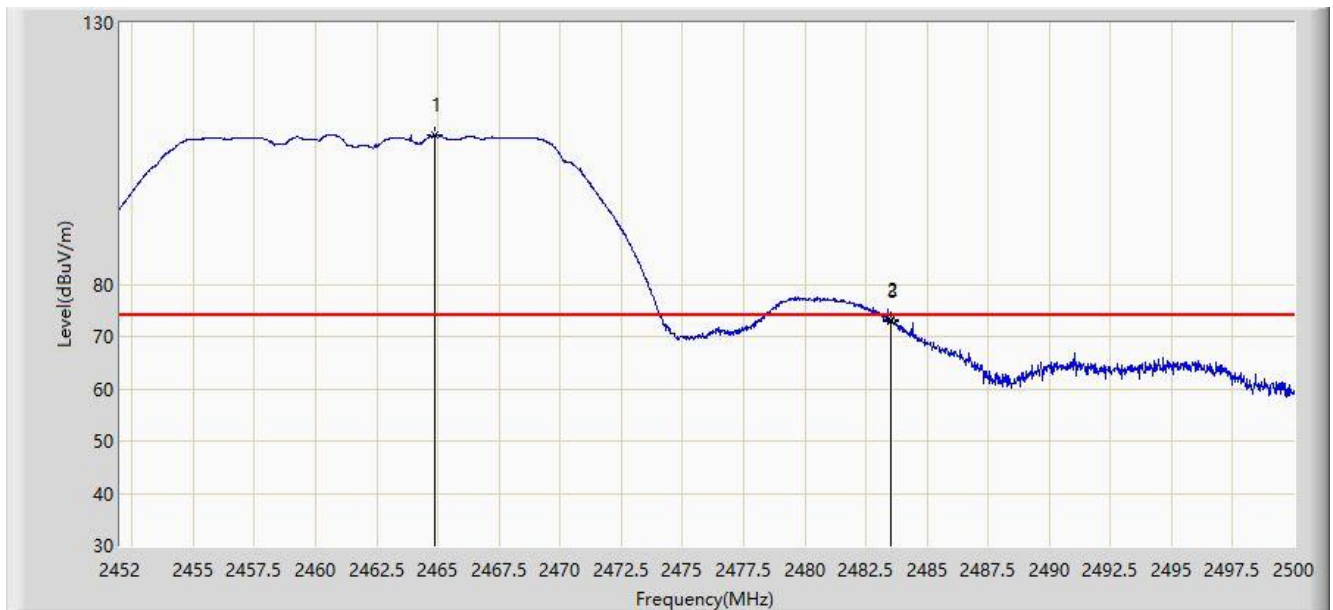

No	Flag	Mark	Frequency (MHz)	Measure Level (dBuV/m)	Reading Level (dBuV)	Over Limit (dB)	Limit (dBuV/m)	Factor (dB)	Type
1		*	2464.888	108.421	76.135	N/A	N/A	32.286	PK
2			2483.500	73.050	40.711	-0.950	74.000	32.340	PK
3			2483.536	72.982	40.643	-1.018	74.000	32.340	PK

Note: Measure Level (dB $\mu$ V/m) = Reading Level (dB $\mu$ V) + Factor (dB)

Factor (dB) = Cable Loss (dB) + Antenna Factor (dB/m)

Site: AC1	Time: 2019/01/16 - 05:20
Limit: FCC_Part15.209_RE(3m)	Engineer: Jone Zhang
Probe: BBHA9120D_1-18GHz	Polarity: Horizontal
EUT: Communication Module	Power: DC 3.3V
Test Mode: Transmit by 802.11g at Channel 2462MHz	

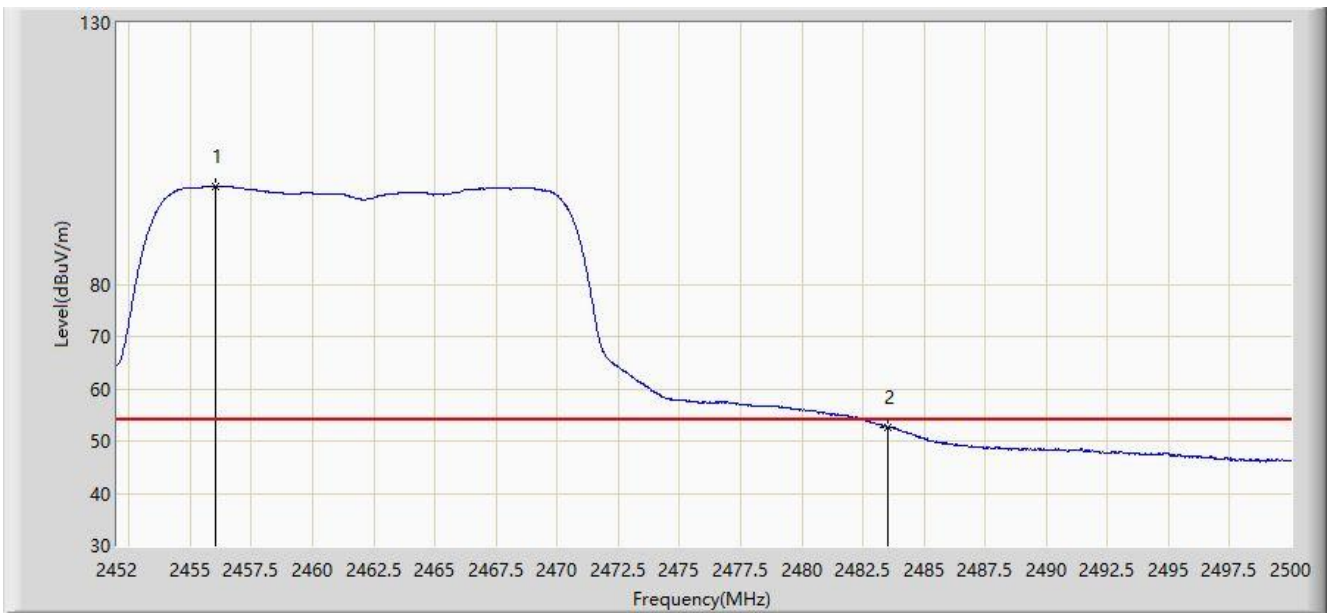

No	Flag	Mark	Frequency (MHz)	Measure Level (dBuV/m)	Reading Level (dBuV)	Over Limit (dB)	Limit (dBuV/m)	Factor (dB)	Type
1		*	2456.008	98.641	66.373	N/A	N/A	32.268	AV
2			2483.500	52.739	20.400	-1.261	54.000	32.340	AV

Note: Measure Level (dB $\mu$ V/m) = Reading Level (dB $\mu$ V) + Factor (dB)

Factor (dB) = Cable Loss (dB) + Antenna Factor (dB/m)



Site: AC1	Time: 2019/01/16 - 05:20
Limit: FCC_Part15.209_RE(3m)	Engineer: Jone Zhang
Probe: BBHA9120D_1-18GHz	Polarity: Vertical
EUT: Communication Module	Power: DC 3.3V
Test Mode: Transmit by 802.11g at Channel 2462MHz	

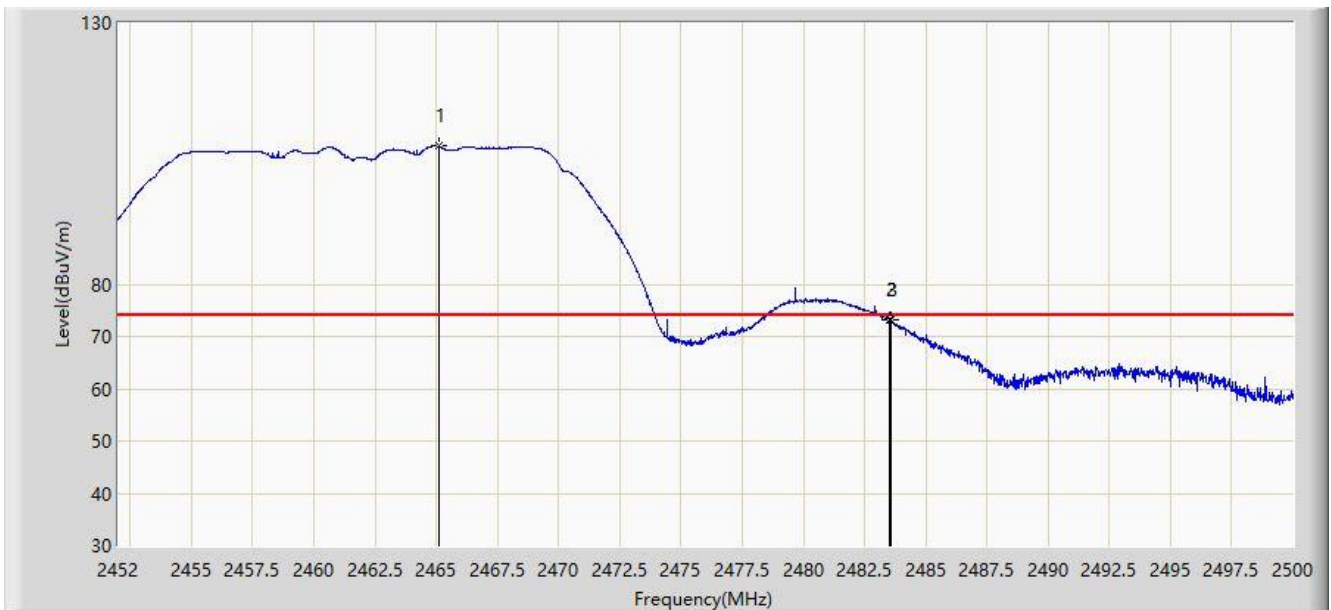

No	Flag	Mark	Frequency (MHz)	Measure Level (dBuV/m)	Reading Level (dBuV)	Over Limit (dB)	Limit (dBuV/m)	Factor (dB)	Type
1		*	2465.104	106.479	74.192	N/A	N/A	32.286	PK
2			2483.500	73.318	40.979	-0.682	74.000	32.340	PK
3			2483.560	73.171	40.832	-0.829	74.000	32.340	PK

Note: Measure Level (dB $\mu$ V/m) = Reading Level (dB $\mu$ V) + Factor (dB)

Factor (dB) = Cable Loss (dB) + Antenna Factor (dB/m)

Site: AC1	Time: 2019/01/16 - 05:23
Limit: FCC_Part15.209_RE(3m)	Engineer: Jone Zhang
Probe: BBHA9120D_1-18GHz	Polarity: Vertical
EUT: Communication Module	Power: DC 3.3V
Test Mode: Transmit by 802.11g at Channel 2462MHz	

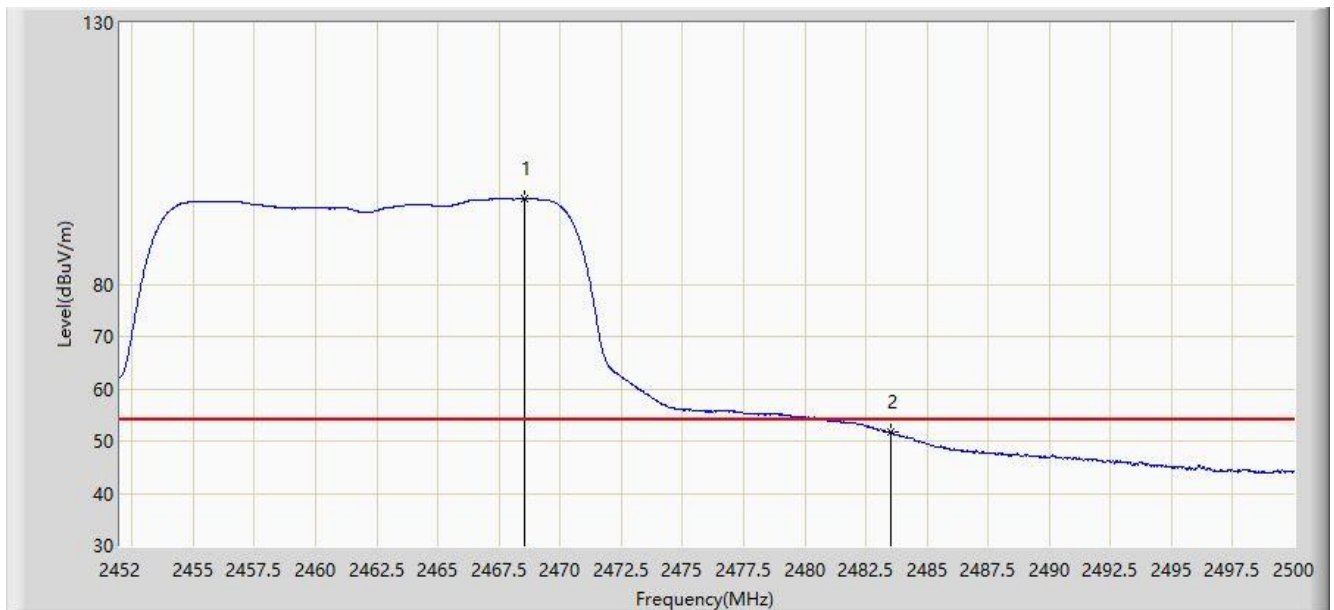

No	Flag	Mark	Frequency (MHz)	Measure Level (dBuV/m)	Reading Level (dBuV)	Over Limit (dB)	Limit (dBuV/m)	Factor (dB)	Type
1		*	2468.536	96.411	64.116	N/A	N/A	32.296	AV
2			2483.500	51.740	19.401	-2.260	54.000	32.340	AV

Note: Measure Level (dB $\mu$ V/m) = Reading Level (dB $\mu$ V) + Factor (dB)

Factor (dB) = Cable Loss (dB) + Antenna Factor (dB/m)

Site: AC1	Time: 2019/01/16 - 05:38
Limit: FCC_Part15.209_RE(3m)	Engineer: Jone Zhang
Probe: BBHA9120D_1-18GHz	Polarity: Horizontal
EUT: Communication Module	Power: DC 3.3V
Test Mode: Transmit by 802.11n-HT20 at Channel 2412MHz	

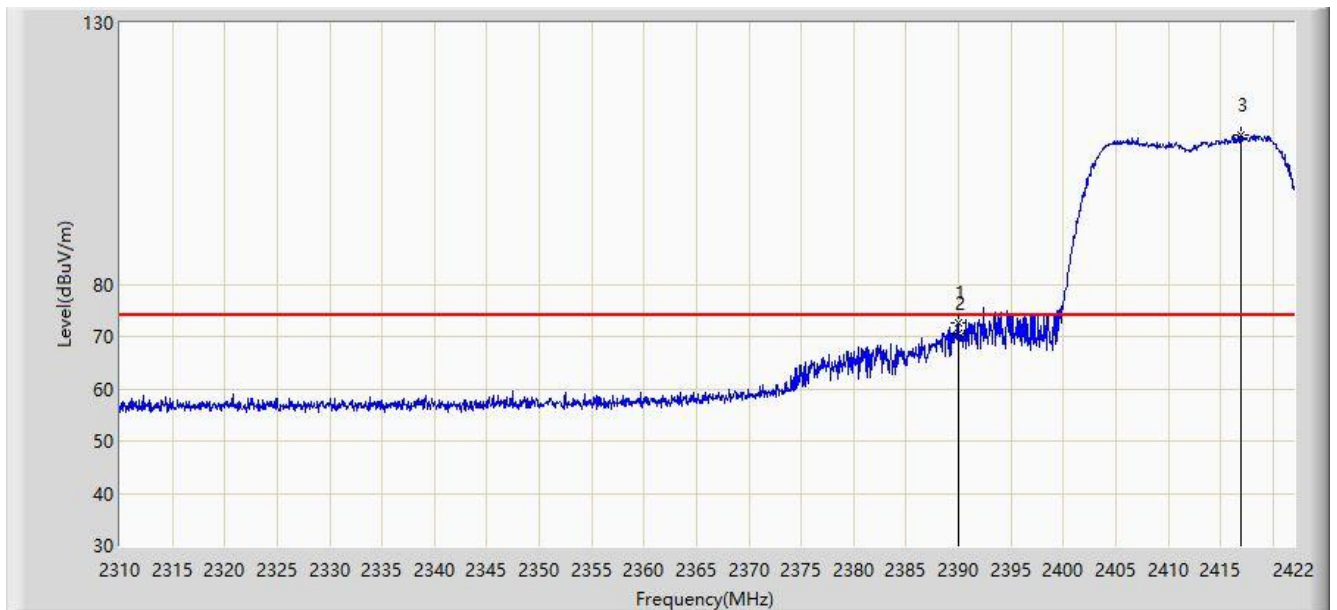

No	Flag	Mark	Frequency (MHz)	Measure Level (dBuV/m)	Reading Level (dBuV)	Over Limit (dB)	Limit (dBuV/m)	Factor (dB)	Type
1			2389.968	72.481	40.154	-1.519	74.000	32.327	PK
2			2390.000	70.711	38.384	-3.289	74.000	32.327	PK
3		*	2417.016	108.644	76.361	N/A	N/A	32.283	PK

Note: Measure Level (dB $\mu$ V/m) = Reading Level (dB $\mu$ V) + Factor (dB)

Factor (dB) = Cable Loss (dB) + Antenna Factor (dB/m)

Site: AC1	Time: 2019/01/16 - 05:40
Limit: FCC_Part15.209_RE(3m)	Engineer: Jone Zhang
Probe: BBHA9120D_1-18GHz	Polarity: Horizontal
EUT: Communication Module	Power: DC 3.3V
Test Mode: Transmit by 802.11n-HT20 at Channel 2412MHz	

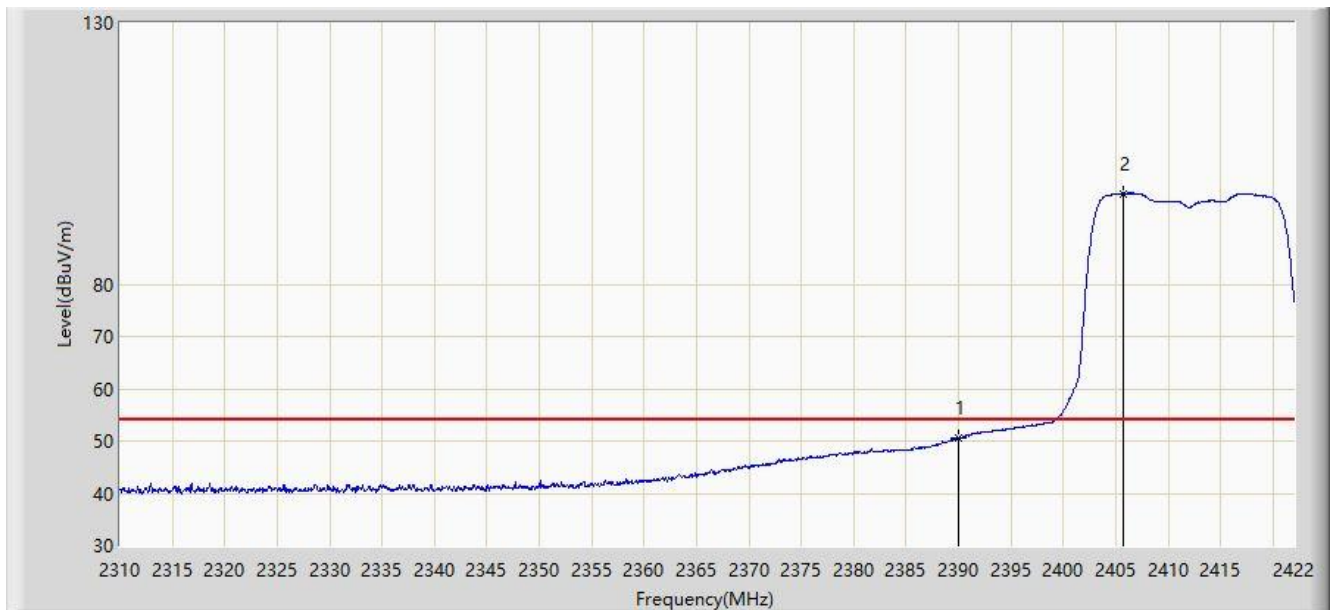

No	Flag	Mark	Frequency (MHz)	Measure Level (dBuV/m)	Reading Level (dBuV)	Over Limit (dB)	Limit (dBuV/m)	Factor (dB)	Type
1			2390.000	50.603	18.276	-3.397	54.000	32.327	AV
2		*	2405.760	97.389	65.093	N/A	N/A	32.296	AV

Note: Measure Level (dB $\mu$ V/m) = Reading Level (dB $\mu$ V) + Factor (dB)

Factor (dB) = Cable Loss (dB) + Antenna Factor (dB/m)

Site: AC1	Time: 2019/01/16 - 05:41
Limit: FCC_Part15.209_RE(3m)	Engineer: Jone Zhang
Probe: BBHA9120D_1-18GHz	Polarity: Vertical
EUT: Communication Module	Power: DC 3.3V
Test Mode: Transmit by 802.11n-HT20 at Channel 2412MHz	

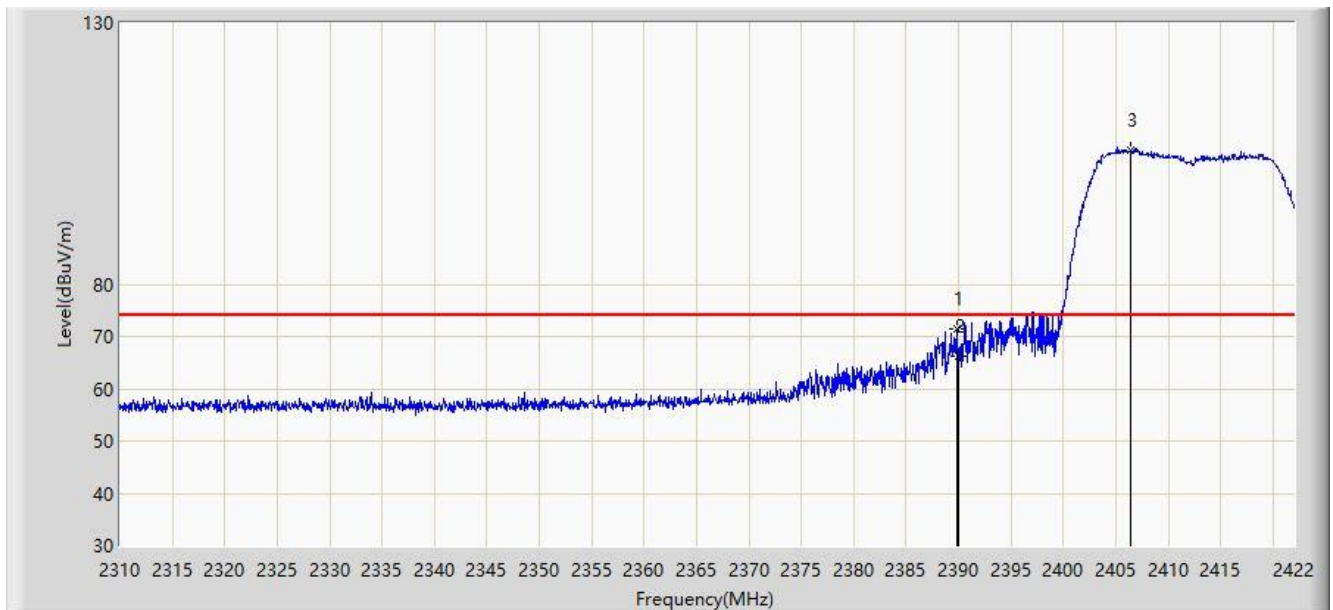

No	Flag	Mark	Frequency (MHz)	Measure Level (dBuV/m)	Reading Level (dBuV)	Over Limit (dB)	Limit (dBuV/m)	Factor (dB)	Type
1			2389.856	71.502	39.175	-2.498	74.000	32.327	PK
2			2390.000	66.351	34.024	-7.649	74.000	32.327	PK
3		*	2406.488	105.674	73.379	N/A	N/A	32.294	PK

Note: Measure Level (dB $\mu$ V/m) = Reading Level (dB $\mu$ V) + Factor (dB)

Factor (dB) = Cable Loss (dB) + Antenna Factor (dB/m)

Site: AC1	Time: 2019/01/16 - 05:44
Limit: FCC_Part15.209_RE(3m)	Engineer: Jone Zhang
Probe: BBHA9120D_1-18GHz	Polarity: Vertical
EUT: Communication Module	Power: DC 3.3V
Test Mode: Transmit by 802.11n-HT20 at Channel 2412MHz	

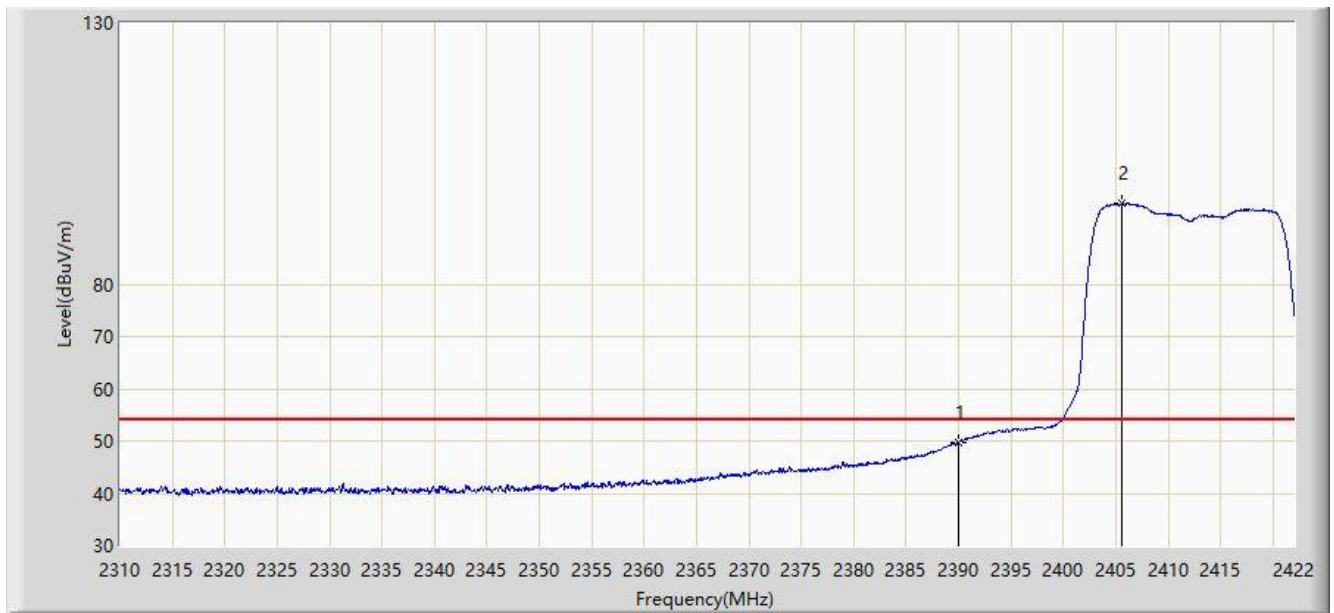

No	Flag	Mark	Frequency (MHz)	Measure Level (dBuV/m)	Reading Level (dBuV)	Over Limit (dB)	Limit (dBuV/m)	Factor (dB)	Type
1			2390.000	49.792	17.465	-4.208	54.000	32.327	AV
2		*	2405.648	95.389	63.092	N/A	N/A	32.297	AV

Note: Measure Level (dB $\mu$ V/m) = Reading Level (dB $\mu$ V) + Factor (dB)

Factor (dB) = Cable Loss (dB) + Antenna Factor (dB/m)

Site: AC1	Time: 2019/01/16 - 05:59
Limit: FCC_Part15.209_RE(3m)	Engineer: Jone Zhang
Probe: BBHA9120D_1-18GHz	Polarity: Horizontal
EUT: Communication Module	Power: DC 3.3V
Test Mode: Transmit by 802.11n-HT20 at Channel 2462MHz	

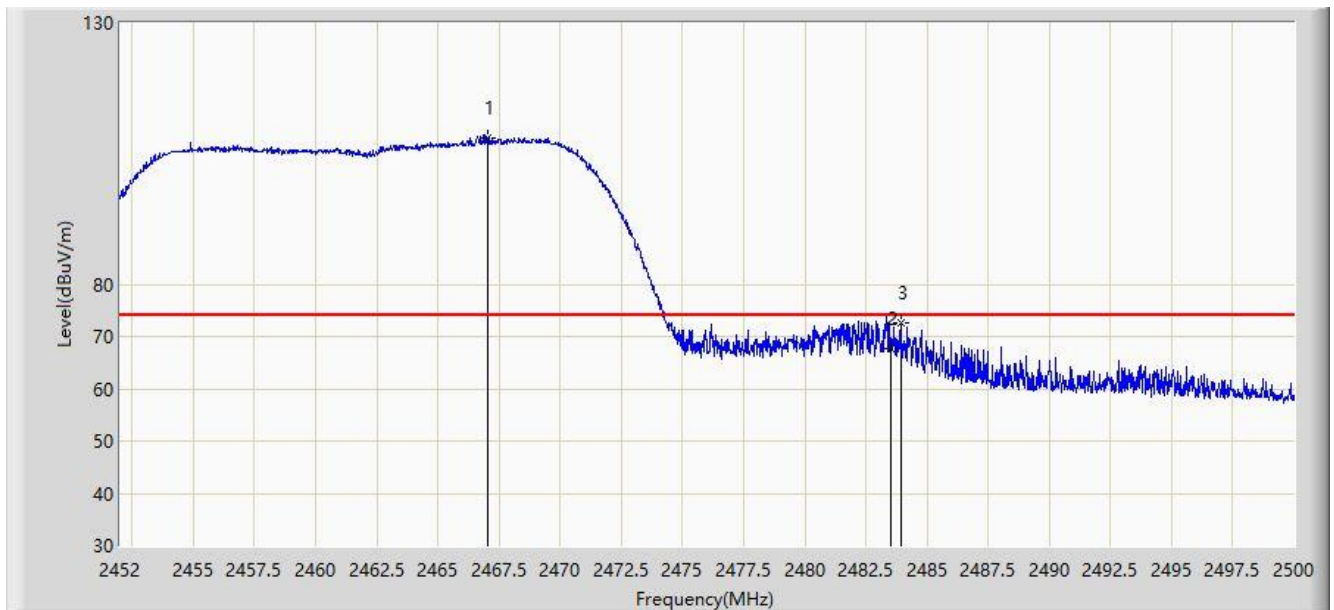

No	Flag	Mark	Frequency (MHz)	Measure Level (dBuV/m)	Reading Level (dBuV)	Over Limit (dB)	Limit (dBuV/m)	Factor (dB)	Type
1		*	2467.048	107.887	75.596	N/A	N/A	32.292	PK
2			2483.500	67.820	35.481	-6.180	74.000	32.340	PK
3			2483.920	72.697	40.356	-1.303	74.000	32.340	PK

Note: Measure Level (dB $\mu$ V/m) = Reading Level (dB $\mu$ V) + Factor (dB)

Factor (dB) = Cable Loss (dB) + Antenna Factor (dB/m)

Site: AC1	Time: 2019/01/16 - 06:02
Limit: FCC_Part15.209_RE(3m)	Engineer: Jone Zhang
Probe: BBHA9120D_1-18GHz	Polarity: Horizontal
EUT: Communication Module	Power: DC 3.3V
Test Mode: Transmit by 802.11n-HT20 at Channel 2462MHz	

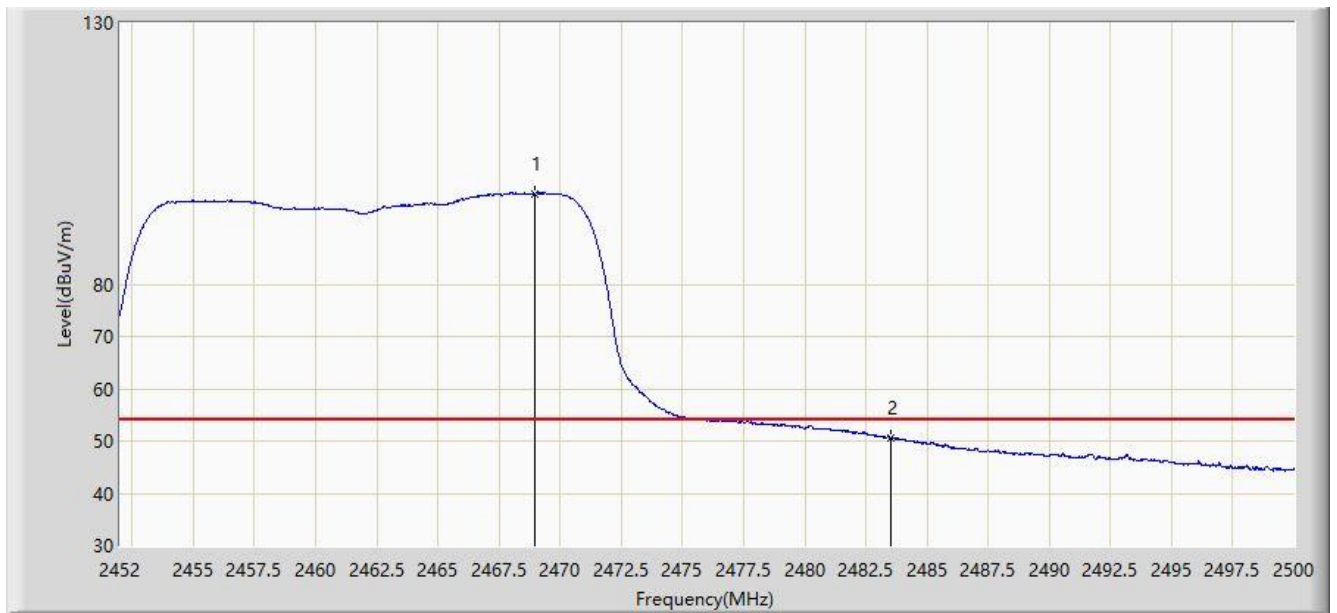

No	Flag	Mark	Frequency (MHz)	Measure Level (dBuV/m)	Reading Level (dBuV)	Over Limit (dB)	Limit (dBuV/m)	Factor (dB)	Type
1		*	2468.992	97.305	65.009	N/A	N/A	32.296	AV
2			2483.500	50.645	18.306	-3.355	54.000	32.340	AV

Note: Measure Level (dBμV/m) = Reading Level (dBμV) + Factor (dB)

Factor (dB) = Cable Loss (dB) + Antenna Factor (dB/m)



Site: AC1	Time: 2019/01/16 - 06:02
Limit: FCC_Part15.209_RE(3m)	Engineer: Jone Zhang
Probe: BBHA9120D_1-18GHz	Polarity: Vertical
EUT: Communication Module	Power: DC 3.3V
Test Mode: Transmit by 802.11n-HT20 at Channel	

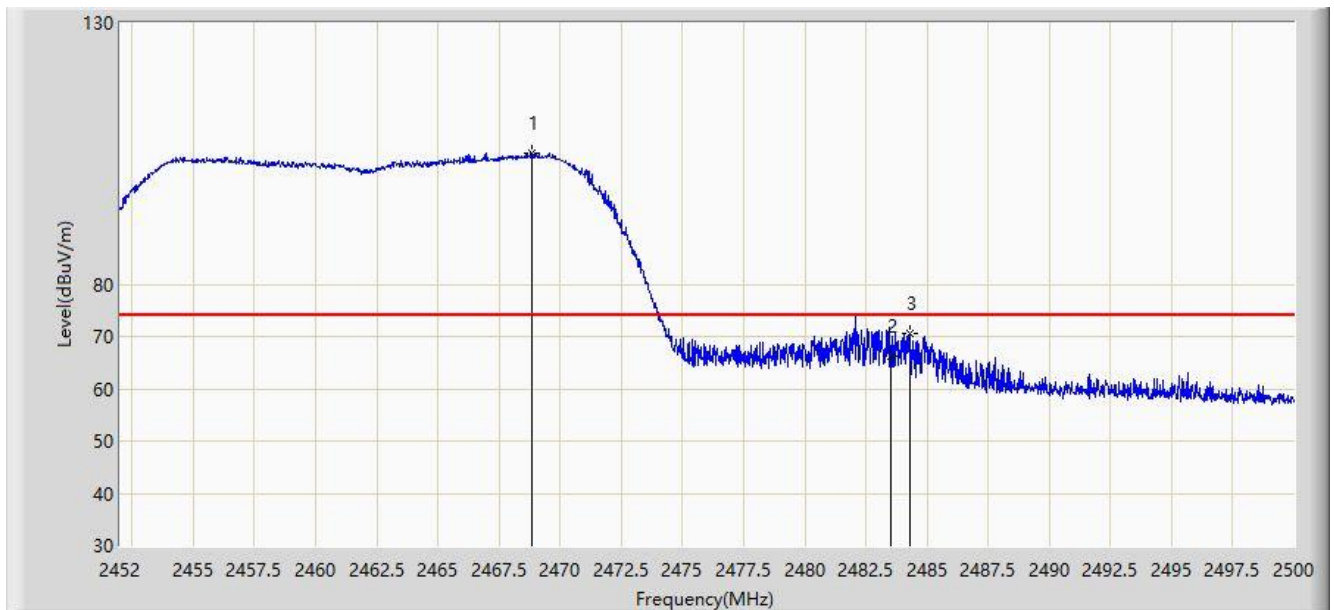

No	Flag	Mark	Frequency (MHz)	Measure Level (dBuV/m)	Reading Level (dBuV)	Over Limit (dB)	Limit (dBuV/m)	Factor (dB)	Type
1		*	2468.848	105.186	72.890	N/A	N/A	32.296	PK
2			2483.500	66.290	33.951	-7.710	74.000	32.340	PK
3			2484.304	70.584	38.242	-3.416	74.000	32.342	PK

Note: Measure Level (dB $\mu$ V/m) = Reading Level (dB $\mu$ V) + Factor (dB)

Factor (dB) = Cable Loss (dB) + Antenna Factor (dB/m)

Site: AC1	Time: 2019/01/16 - 06:05
Limit: FCC_Part15.209_RE(3m)	Engineer: Jone Zhang
Probe: BBHA9120D_1-18GHz	Polarity: Vertical
EUT: Communication Module	Power: DC 3.3V
Test Mode: Transmit by 802.11n-HT20 at Channel	

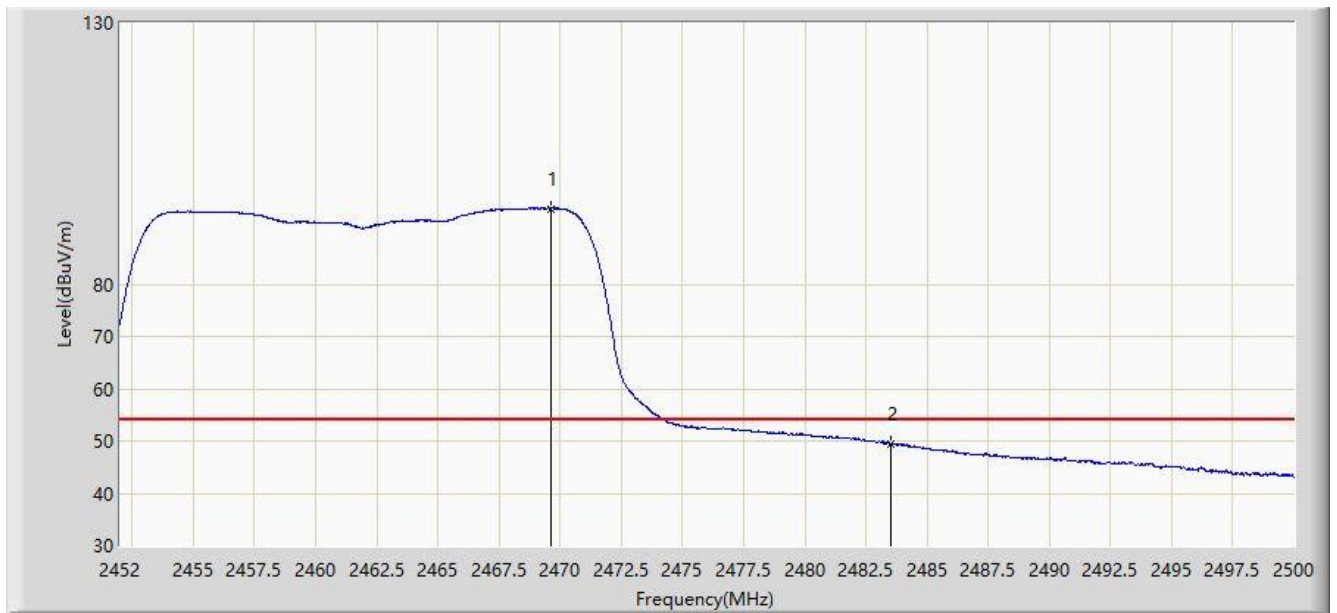

No	Flag	Mark	Frequency (MHz)	Measure Level (dBuV/m)	Reading Level (dBuV)	Over Limit (dB)	Limit (dBuV/m)	Factor (dB)	Type
1		*	2469.640	94.461	62.163	N/A	N/A	32.298	AV
2			2483.500	49.526	17.187	-4.474	54.000	32.340	AV

Note: Measure Level (dBμV/m) = Reading Level (dBμV) + Factor (dB)

Factor (dB) = Cable Loss (dB) + Antenna Factor (dB/m)

## 6.8. AC Conducted Emissions Measurement

### 6.8.1. Test Limit

FCC Part 15 Subpart C Paragraph 15.207 Limits		
Frequency (MHz)	QP (dBuV)	AV (dBuV)
0.15 ~ 0.50	66 ~ 56	56 ~ 46
0.50 ~ 5.0	56	46
5.0 ~ 30	60	50

Note 1: The lower limit shall apply at the transition frequencies.

Note 2: The limit decreases linearly with the logarithm of the frequency in the range 0.15MHz to 0.5MHz.

### 6.8.2. Test Setup

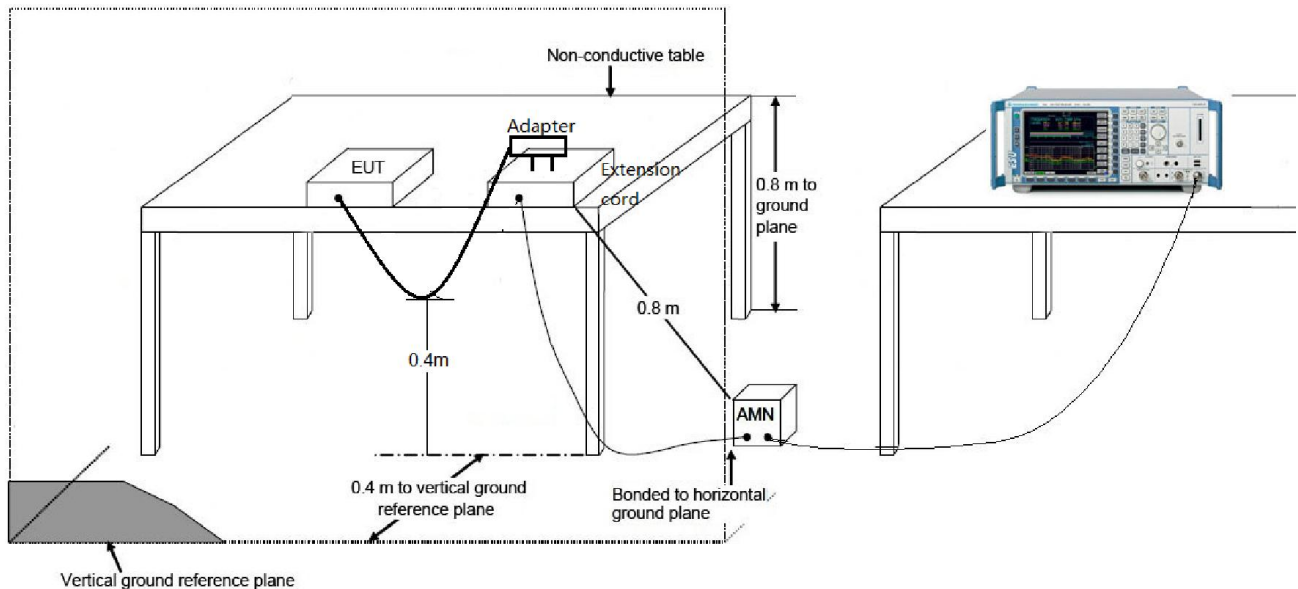

### 6.8.3. Test Result

The EUT is supplied by DC 5V, so this item is not application.

## 7. CONCLUSION

The data collected relate only the item(s) tested and show that the **Communication Module** is in compliance with Part 15C of the FCC Rules & RSS-247 Issue 2 of ISED Rules..

————— The End —————

## Appendix A – Test Setup Photograph

Refer to “1901WSU002-UT” file.

## **Appendix B – EUT Photograph**

Refer to “ 1901WSU002-UE” file.