



MEASUREMENT REPORT

FCC PART 15.247 & IC RSS-247 Bluetooth

FCC ID: VPYLBEE59B1LV
IC: 772C-LBEE59B1LV
APPLICANT: Murata Manufacturing Co., Ltd.

Application Type: Certification
Product: Communication Module
Model No.: Type1LV
FCC Classification: FCC Part 15 Spread Spectrum Transmitter(DSS)
FCC Rule Part(s): Part 15 Subpart C (Section 15.247)
IC Rule(s): RSS-247 Issue 2, RSS-GEN Issue 5
Test Procedure(s): ANSI C63.10-2013, KDB 558074 D01v05r01
Test Date: March 01 ~ March 07, 2019

Reviewed By:

(Kevin Guo)

Approved By:

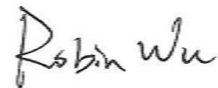
(Robin Wu)



The test results relate only to the samples tested.

This equipment has been shown to be capable of compliance with the applicable technical standards as indicated in the measurement report and was tested in accordance with the measurement procedures specified in ANSI C63.10-2013. Test results reported herein relate only to the item(s) tested.

The test report shall not be reproduced except in full without the written approval of MRT Technology (Suzhou) Co., Ltd.

Revision History

Report No.	Version	Description	Issue Date	Note
1901WSU002-U4	Rev. 01	Initial Report	03-28-2019	Valid

CONTENTS

Description	Page
1. INTRODUCTION	7
1.1. Scope	7
1.2. MRT Test Location	7
2. PRODUCT INFORMATION	8
2.1. Feature of Equipment under Test	8
2.2. Product Specification Subjective to this Standard	8
2.3. Operation Frequency / Channel List	9
2.4. Pseudorandom Frequency Hopping Sequence.....	10
2.5. Description of Test Software.....	10
2.6. Test Configuration	10
2.7. EMI Suppression Device(s)/Modifications.....	10
2.8. Labeling Requirements.....	11
3. DESCRIPTION of TEST	12
3.1. Evaluation Procedure	12
3.2. AC Line Conducted Emissions	12
3.3. Radiated Emissions.....	13
4. TEST EQUIPMENT CALIBRATION DATE	14
5. MEASUREMENT UNCERTAINTY.....	16
6. TEST RESULT	17
6.1. Summary	17
6.2. 20dB Bandwidth Measurement.....	18
6.2.1. Test Limit	18
6.2.2. Test Procedure used.....	18
6.2.3. Test Setting.....	18
6.2.4. Test Setup.....	18
6.2.5. Test Result.....	19
6.3. Output Power Measurement.....	22
6.3.1. Test Limit	22
6.3.2. Test Procedure Used	22
6.3.3. Test Setting.....	22
6.3.4. Test Setup.....	22
6.3.5. Test Result.....	23
6.4. Carrier Frequency Separation Measurement.....	27
6.4.1. Test Limit	27

6.4.2.	Test Procedure Used	27
6.4.3.	Test Setting	27
6.4.4.	Test Setup.....	27
6.4.5.	Test Result.....	28
6.5.	Number of Hopping Channels Measurement	31
6.5.1.	Test Limit	31
6.5.2.	Test Procedure Used	31
6.5.3.	Test Setting.....	31
6.5.4.	Test Setup.....	31
6.5.5.	Test Result.....	32
6.6.	Time of Occupancy Measurement	35
6.6.1.	Test Limit	35
6.6.2.	Test Procedure Used	35
6.6.3.	Test Setting.....	35
6.6.4.	Test Setup.....	35
6.6.5.	Test Result.....	36
6.7.	Band-edge Compliance Measurement.....	38
6.7.1.	Test Limit	38
6.7.2.	Test Procedure Used	38
6.7.3.	Test Setting.....	38
6.7.4.	Test Setup.....	39
6.7.5.	Test Result.....	40
6.8.	Conducted Spurious Emissions Measurement.....	43
6.8.1.	Test Limit	43
6.8.2.	Test Procedure Used	43
6.8.3.	Test Setting.....	43
6.8.4.	Test Setup.....	44
6.8.5.	Test Result.....	45
6.9.	Radiated Spurious Emission Measurement	48
6.9.1.	Test Limit	48
6.9.2.	Test Procedure Used	48
6.9.3.	Test Setting.....	48
6.9.4.	Test Setup.....	50
6.9.5.	Test Result.....	51
6.10.	Radiated Restricted Band Edge Measurement	62
6.10.1.	Test Limit	62
6.10.2.	Test Procedure Used	65
6.10.3.	Test Setting.....	65

6.10.4.	Test Setup.....	66
6.10.5.	Test Result.....	67
6.11.	AC Conducted Emissions Measurement.....	91
6.11.1.	Test Limit	91
6.11.2.	Test Setup.....	91
6.11.3.	Test Result.....	91
7.	CONCLUSION.....	92
	Appendix A – Test Setup Photograph.....	93
	Appendix B – EUT Photograph	94

§2.1033 General Information

Applicant:	Murata Manufacturing Co., Ltd.
Applicant Address:	10-1, Higashikotari 1-chome, Nagaokakyo-shi, Kyoto 617-8555, Japan
Manufacturer:	Murata Manufacturing Co., Ltd.
Manufacturer Address:	10-1, Higashikotari 1-chome, Nagaokakyo-shi, Kyoto 617-8555, Japan
Test Site:	MRT Technology (Suzhou) Co., Ltd
Test Site Address:	D8 Building, Youxin Industrial Park, No.2 Tian'edang Rd., Wuzhong Economic Development Zone, Suzhou, China
FCC Registration No.:	893164
IC Registration No.:	11384A-1
Test Device Serial No.:	N/A <input type="checkbox"/> Production <input checked="" type="checkbox"/> Pre-Production <input type="checkbox"/> Engineering

Test Facility / Accreditations

Measurements were performed at MRT Laboratory located in Tian'edang Rd., Suzhou, China.

- MRT facility is a FCC registered (MRT Reg. No. 893164) test facility with the site description report on file and has met all the requirements specified in ANSI C63.4-2014.
- MRT facility is an IC registered (MRT Reg. No. 11384A-1) test laboratory with the site description on file at Industry Canada.
- MRT facility is a VCCI registered (R-20025, G-20034, C-20020, T-20020) test laboratory with the site description on file at VCCI Council.
- MRT Lab is accredited to ISO 17025 by the American Association for Laboratory Accreditation (A2LA) under the American Association for Laboratory Accreditation Program (A2LA Cert. No. 3628.01) in EMC, Telecommunications, Radio and SAR testing.



1. INTRODUCTION

1.1. Scope

Measurement and determination of electromagnetic emissions (EMC) of radio frequency devices including intentional and/or unintentional radiators for compliance with the technical rules and regulations of the Federal Communications Commission and the Industry Canada Certification and Engineering Bureau.

1.2. MRT Test Location

The map below shows the location of the MRT LABORATORY, its proximity to the Taihu Lake. These measurement tests were conducted at the MRT Technology (Suzhou) Co., Ltd. Facility located at D8 Building, No.2 Tian'edang Rd., Wuzhong Economic Development Zone, Suzhou, China. The measurement facility compliant with the test site requirements specified in ANSI C63.4-2014.



2. PRODUCT INFORMATION

2.1. Feature of Equipment under Test

Product Name:	Communication Module
Model No.:	Type1LV
Brand Name:	Murata
Work Voltage	DC 3.3V
WiFi Specification	802.11 a/b/g/n/ac
Bluetooth Specification	BR / EDR / LE 1Mbps / LE 2Mbps

Note: Work voltage of test fixture is DC 5V.

2.2. Product Specification Subjective to this Standard

Operating Frequency	2402~2480MHz
Channel Number	79
Type of modulation	GFSK, Pi/4 DQPSK, 8DPSK
Data Rate	1Mbps(GFSK), 2Mbps(Pi/4 DQPSK), 3Mbps (8DPSK)
Antenna type	PCB Antenna
Antenna Gain	0.9dBi

The equipment under test (EUT) is the **Communication Module**. The test data contained in this report pertains only to the emissions due to the EUT's Bluetooth transmitter.

- 15.247(g): In accordance with the Bluetooth Industry Standard, the system is designed to comply with all of the regulations in Section 15.247 when the transmitter is presented with a continuous data (or information) system.
- 15.247(h): In accordance with the Bluetooth Industry Standard, the system does not coordinate its channels selection/ hopping sequence with other frequency hopping systems for the express purpose of avoiding the simultaneous occupancy of individual hopping frequencies by multiple transmitters.
- 15.247(h): The EUT employs Adaptive Frequency Hopping (AFH) which identifies sources of interference namely devices operating in 802.11 WLAN and excludes them from the list of available channels. The process of re-mapping reduces the number of test channels from 79 channels to a minimum number of 20 channels.

2.3. Operation Frequency / Channel List

Channel	Frequency	Channel	Frequency	Channel	Frequency
00	2402 MHz	01	2403 MHz	02	2404 MHz
03	2405 MHz	04	2406 MHz	05	2407 MHz
06	2408 MHz	07	2409 MHz	08	2410 MHz
09	2411 MHz	10	2412 MHz	11	2413 MHz
12	2414 MHz	13	2415 MHz	14	2416 MHz
15	2417 MHz	16	2418 MHz	17	2419 MHz
18	2420 MHz	19	2421 MHz	20	2422 MHz
21	2423 MHz	22	2424 MHz	23	2425 MHz
24	2426 MHz	25	2427 MHz	26	2428 MHz
27	2429 MHz	28	2430 MHz	29	2431 MHz
30	2432 MHz	31	2433 MHz	32	2434 MHz
33	2435 MHz	34	2436 MHz	35	2437 MHz
36	2438 MHz	37	2439 MHz	38	2440 MHz
39	2441 MHz	40	2442 MHz	41	2443 MHz
42	2444 MHz	43	2445 MHz	44	2446 MHz
45	2447 MHz	46	2448 MHz	47	2449 MHz
48	2450 MHz	49	2451 MHz	50	2452 MHz
51	2453 MHz	52	2454 MHz	53	2455 MHz
54	2456 MHz	55	2457 MHz	56	2458 MHz
57	2459 MHz	58	2460 MHz	59	2461 MHz
60	2462 MHz	61	2463 MHz	62	2464 MHz
63	2465 MHz	64	2466 MHz	65	2467 MHz
66	2468 MHz	67	2469 MHz	68	2470 MHz
69	2471 MHz	70	2472 MHz	71	2473 MHz
72	2474 MHz	73	2475 MHz	74	2476 MHz
75	2477 MHz	76	2478 MHz	77	2479 MHz
78	2480 MHz	-	-	-	-

2.4. Pseudorandom Frequency Hopping Sequence

The pseudorandom sequence may be generated in a nine-stage shift register whose 5th and 9th stage outputs are added in a modulo-two addition stage. And the result is fed back to the input of the first stage. The sequence begins with the first ONE of 9 consecutive ONES; i.e. the shift register is initialized with nine ones.

- Number of shift register stages: 9
- Length of pseudo-random sequence: $2^9 - 1 = 511$ bits
- Longest sequence of zeros: 8 (non-inverted signal)

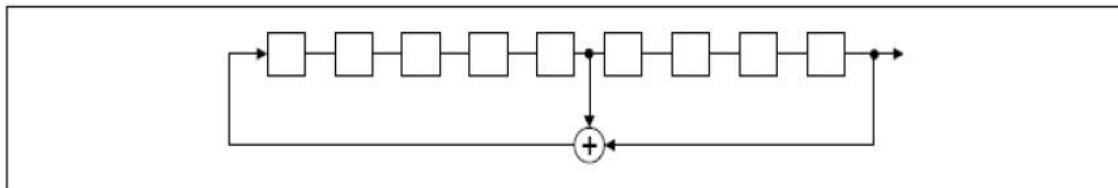

Linear Feedback Shift Register for Generation of the PRBS sequence

An example of Pseudorandom Frequency Hopping Sequence as follow:

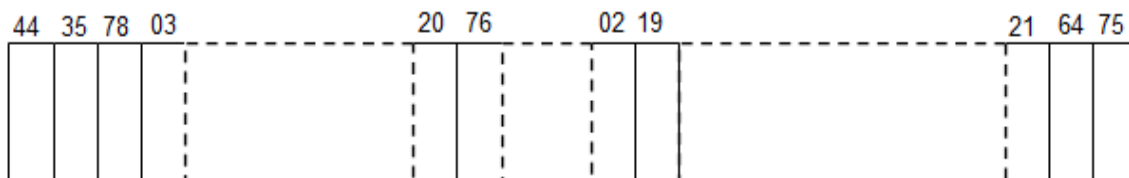

Each frequency used equally on the average by each transmitter.

The system receivers have input bandwidths that match the hopping channel bandwidths of their Corresponding transmitters and shift frequencies in synchronization with the transmitted signals.

2.5. Description of Test Software

The test utility software used during testing was “Tera Term”, and the version was “v4.78”.

2.6. Test Configuration

The **Communication Module** was tested per the guidance of ANSI C63.10-2013. ANSI C63.10-2013 was used to reference the appropriate EUT setup for radiated spurious emissions testing and AC line conducted testing.

2.7. EMI Suppression Device(s)/Modifications

No EMI suppression device(s) were added and/or no modifications were made during testing.

2.8. Labeling Requirements

Per 2.1074 & 15.19; Docket 95-19

The label shall be permanently affixed at a conspicuous location on the device; instruction manual or pamphlet supplied to the user and be readily visible to the purchaser at the time of purchase.

However, when the device is so small wherein placement of the label with specified statement is not practical, only the FCC ID must be displayed on the device per Section 15.19(a)(5). Please see attachment for FCC ID label and label location.

RSP-100 Issue 11 Section 3

The manufacturer, importer or distributor shall meet the labelling requirements set out in this section for every unit:

- (i) prior to marketing in Canada, for products manufactured in Canada
- (ii) prior to importation into Canada, for imported products

For information regarding the e-labelling option, see Notice 2014–DRS1003. The label for the certified product represents the manufacturer's or importer's compliance with Innovation, Science and Economic Development Canada's (ISED) regulatory requirements.

Please see attachment for IC label and label location.

3. DESCRIPTION of TEST

3.1. Evaluation Procedure

The measurement procedures described in the American National Standard for Testing Unlicensed Wireless Devices (ANSI C63.10 -2013), and the “Filing was used in the measurement of the device.

Deviation from measurement procedure.....None

3.2. AC Line Conducted Emissions

The line-conducted facility is located inside an 8'x4'x4' shielded enclosure. A 1m x 2m wooden table 80cm high is placed 40cm away from the vertical wall and 80cm away from the sidewall of the shielded room. Two 10kHz-30MHz, 50Ω/50uH Line-Impedance Stabilization Networks (LISNs) are bonded to the shielded room floor. Power to the LISNs is filtered by external high-current high-insertion loss power line filters. These filters attenuate ambient signal noise from entering the measurement lines. These filters are also bonded to the shielded enclosure.

The EUT is powered from one LISN and the support equipment is powered from the second LISN. All interconnecting cables more than 1 meter were shortened to a 1 meter length by non-inductive bundling (serpentine fashion) and draped over the back edge of the test table. All cables were at least 40cm above the horizontal reference ground-plane. Power cables for support equipment were routed down to the second LISN while ensuring that that cables were not draped over the second LISN.

Sufficient time for the EUT, support equipment, and test equipment was allowed in order for them to warm up to their normal operating condition. The RF output of the LISN was connected to the receiver and exploratory measurements were made to determine the frequencies producing the maximum emission from the EUT. The receiver was scanned from 150KHz to 30MHz. The detector function was set to peak mode for exploratory measurements while the bandwidth of the analyzer was set to 9kHz. The EUT, support equipment, and interconnecting cables were arranged and manipulated to maximize each emission. Each emission was also maximized by varying: power lines, the mode of operation or data exchange speed, or support equipment whichever determined the worst-case emission. Once the worst case emissions have been identified, the one EUT cable configuration/arrangement and mode of operation that produced these emissions were used for final measurements on the same test site. The analyzer is set to CISPR quasi-peak and average detectors with a 9kHz resolution bandwidth for final measurements.

An extension cord was used to connect to a single LISN which powered by EUT. The extension cord was calibrated with LISN, the impedance and insertion loss are compliance with the requirements as stated in ANSI C63.10-2013.

3.3. Radiated Emissions

The radiated test facilities consisted of an indoor 3 meter semi-anechoic chamber used for final measurements and exploratory measurements, when necessary. The measurement area is contained within the semi-anechoic chamber which is shielded from any ambient interference. For measurements above 1GHz absorbers are arranged on the floor between the turn table and the antenna mast in such a way so as to maximize the reduction of reflections. For measurements below 1GHz, the absorbers are removed. An MF Model 210SS turntable is used for radiated measurement. It is a continuously rotatable, remote controlled, metallic turntable and 2 meters (6.56 ft.) in diameter. The turn table is flush with the raised floor of the chamber in order to maintain its function as a ground plane. An 80cm high PVC support structure is placed on top of the turntable.

For all measurements, the spectrum was scanned through all EUT azimuths and from 1 to 4 meter receive antenna height using a broadband antenna from 30MHz up to the upper frequency shown in 15.33(b)(1) depending on the highest frequency generated or used in the device or on which the device operates or tunes. For frequencies above 1GHz, linearly polarized double ridge horn antennas were used. For frequencies below 30MHz, a calibrated loop antenna was used. When exploratory measurements were necessary, they were performed at 1 meter test distance inside the semi-anechoic chamber using broadband antennas, broadband amplifiers, and spectrum analyzers to determine the frequencies and modes producing the maximum emissions. Sufficient time for the EUT, support equipment, and test equipment was allowed in order for them to warm up to their normal operating condition. The test set-up for frequencies below 1GHz was placed on top of the 0.8 meter high, 1 x 1.5 meter table; and test set-up for frequencies 1-40GHz was placed on top of the 1.5 meter high, 1 x 1.5 meter table. The EUT, support equipment, and interconnecting cables were arranged and manipulated to maximize each emission. Appropriate precaution was taken to ensure that all emissions from the EUT were maximized and investigated. The system configuration, clock speed, mode of operation or video resolution, if applicable, turntable azimuth, and receive antenna height was noted for each frequency found.

Final measurements were made in the semi-anechoic chamber using calibrated, linearly polarized broadband and horn antennas. The test setup was configured to the setup that produced the worst case emissions. The spectrum analyzer was set to investigate all frequencies required for testing to compare the highest radiated disturbances with respect to the specified limits. The turntable containing the EUT was rotated through 360 degrees and the height of the receive antenna was varied 1 to 4 meters and stopped at the azimuth and height producing the maximum emission. Each emission was maximized by changing the orientation of the EUT through three orthogonal planes and changing the polarity of the receive antenna, whichever produced the worst-case emissions. According to 3dB Beamwidth of horn antenna, the horn antenna should be always directed to the EUT when rising height.

4. TEST EQUIPMENT CALIBRATION DATE

Conducted Emissions - SR2

Instrument	Manufacturer	Type No.	Asset No.	Cali. Interval	Cali. Due Date
EMI Test Receiver	R&S	ESR3	MRTSUE06185	1 year	2019/04/20
Two-Line V-Network	R&S	ENV 216	MRTSUE06002	1 year	2019/06/15
Two-Line V-Network	R&S	ENV 216	MRTSUE06003	1 year	2019/06/15
Thermohygrometer	Testo	608-H1	MRTSUE06404	1 year	2019/08/15
Shielding Anechoic Chamber	Mikebang	Chamber-SR2	MRTSUE06214	N/A	N/A

Conducted Test Equipment - TR3

Instrument	Manufacturer	Type No.	Asset No.	Cali. Interval	Cali. Due Date
EXA Signal Analyzer	KEYSIGHT	N9010B	MRTSUE06452	1 year	2019/07/20
Spectrum Analyzer	Agilent	N9020A	MRTSUE06106	1 year	2019/04/20
USB wideband power sensor	KEYSIGHT	U2021XA	MRTSUE06446	1 year	2019/07/20
Attenuator	MVE	MVE2211-10	MRTSUE06800	1 year	2019/07/10
Temperature & Humidity Chamber	BAOYT	BYH-150CL	MRTSUE06051	1 year	2019/12/06
Thermohygrometer	testo	608-H1	MRTSUE06401	1 year	2019/08/15

Radiated Emissions - AC1

Instrument	Manufacturer	Type No.	Asset No.	Cali. Interval	Cali. Due Date
EMI Test Receiver	R&S	ESR7	MRTSUE06001	1 year	2019/08/14
PXA Signal Analyzer	Keysight	9030B	MRTSUE06395	1 year	2019/09/14
Loop Antenna	Schwarzbeck	FMZB 1519	MRTSUE06025	1 year	2019/11/20
Bilog Period Antenna	Schwarzbeck	VULB 9168	MRTSUE06172	1 year	2019/04/12
Broad Band Horn Antenna	Schwarzbeck	BBHA 9120D	MRTSUE06023	1 year	2019/10/20
Broad Band Horn Antenna	Schwarzbeck	BBHA 9170	MRTSUE06024	1 year	2019/12/17
Broadband Coaxial Preamp	Agilent	83017A	MRTSUE06076	1 year	2019/11/16
Preamp	Schwarzbeck	BBV 9721	MRTSUE06121	1 year	2019/06/12
Digital Thermometer & Hygrometer	Testo	608-H1	MRTSUE06403	1 year	2019/08/15
Anechoic Chamber	TDK	Chamber-AC1	MRTSUE06213	1 year	2019/05/02

Radiated Emissions - AC2

Instrument	Manufacturer	Type No.	Asset No.	Cali. Interval	Cali. Due Date
Spectrum Analyzer	Keysight	N9038A	MRTSUE06125	1 year	2019/08/14
Loop Antenna	Schwarzbeck	FMZB 1519	MRTSUE06025	1 year	2019/11/09
Bilog Period Antenna	Schwarzbeck	VULB 9162	MRTSUE06022	1 year	2019/10/20
Horn Antenna	Schwarzbeck	BBHA9120D	MRTSUE06171	1 year	2019/11/09
Broadband Horn Antenna	Schwarzbeck	BBHA9170	MRTSUE06024	1 year	2019/12/17
Broadband Coaxial Preampfier	Schwarzbeck	BBV 9718	MRTSUE06176	1 year	2019/11/16
Preampfier	Schwarzbeck	BBV 9721	MRTSUE06121	1 year	2019/06/13
Temperature/Humidity Meter	Minggao	ETH529	MRTSUE06170	1 year	2019/12/13
Anechoic Chamber	RIKEN	Chamber-AC2	MRTSUE06213	1 year	2019/05/02

Software	Version	Function
e3	V 8.3.5	EMI Test Software

5. MEASUREMENT UNCERTAINTY

Where relevant, the following test uncertainty levels have been estimated for tests performed on the EUT as specified in CISPR 16-4-2. This uncertainty represents an expanded uncertainty expressed at approximately the 95% confidence level using a coverage factor of $k = 2$.

AC Conducted Emission Measurement - SR2
Measuring Uncertainty for a Level of Confidence of 95% ($U=2Uc(y)$): 150kHz~30MHz: 3.46dB
Radiated Emission Measurement - AC1
Measuring Uncertainty for a Level of Confidence of 95% ($U=2Uc(y)$): 9kHz ~ 1GHz: 4.18dB 1GHz ~ 25GHz: 4.76dB
Radiated Emission Measurement - AC2
Measuring Uncertainty for a Level of Confidence of 95% ($U=2Uc(y)$): 9kHz ~ 1GHz: 3.86dB 1GHz ~ 25GHz: 4.33dB
Spurious Emissions, Conducted - TR3
Measuring Uncertainty for a Level of Confidence of 95% ($U=2Uc(y)$): 0.78dB
Output Power - TR3
Measuring Uncertainty for a Level of Confidence of 95% ($U=2Uc(y)$): 1.13dB
Power Spectrum Density - TR3
Measuring Uncertainty for a Level of Confidence of 95% ($U=2Uc(y)$): 1.15dB
Occupied Bandwidth - TR3
Measuring Uncertainty for a Level of Confidence of 95% ($U=2Uc(y)$): 0.28%

6. TEST RESULT

6.1. Summary

Company Name: Murata Manufacturing Co., Ltd.
FCC ID: VPYLBEE59B1LV
IC: 772C-LBEE59B1LV

FCC Part Section(s)	IC Section(s)	Test Description	Test Limit	Test Condition	Test Result	Reference
15.247(a)(1)	RSS-247 [5.1]	20dB Bandwidth	N/A	Conducted	PASS	Section 6.2
15.247(b)(1)	RSS-247 [5.4(b)]	Peak Transmitter Output Power	<0.125 Watt		PASS	Section 6.3
15.247(a)(1)	RSS-247 [5.1]	Channel Separation	> 2/3 of 20 dB BW for systems with Output Power < 125mW		PASS	Section 6.4
15.247(a)(1) (iii)	RSS-247 [5.1]	Number of Channels	> 15 Channels		PASS	Section 6.5
15.247(a)(1) (iii)	RSS-247 [5.1]	Time of Occupancy	< 0.4 sec in 31.6 sec period		PASS	Section 6.6
15.247(d)	RSS-247 [5.5]	Band Edge / out-of-Band Emissions	Conducted \leq 20dBc		PASS	Section 6.7 Section 6.8
15.205, 15.209	RSS-247 [5.5]	General Field Strength Limits (Restricted Bands and Radiated Emission Limits)	Emissions in restricted bands must meet the radiated limits detailed in 15.209	Radiated	PASS	Section 6.9 Section 6.10
15.207	RSS-Gen [8.8]	AC Conducted Emissions 150kHz - 30MHz	< FCC 15.207 limits	Line Conducted	N/A	Section 6.11

Notes:

- The analyzer plots shown in this section were all taken with a correction table loaded into the analyzer. The correction table was used to account for the losses of the cables and attenuators used as part of the system to connect the EUT to the analyzer at all frequencies of interest.
- All modes of operation and data rates were investigated. For radiated emission test, every axis (X, Y, Z) was also verified. The test results shown in the following sections represent the worst case emissions.
- N/A means Not Applicable.

6.2. 20dB Bandwidth Measurement

6.2.1. Test Limit

N/A

6.2.2. Test Procedure used

ANSI C63.10-2013 - Section 6.9.2

6.2.3. Test Setting

1. Set RBW $\geq 1\%$ of the 20dB bandwidth
2. VBW $\geq 3 \times$ RBW
3. Span = approximately 2 to 5 times the 20dB bandwidth, centered on a hopping channel
4. Detector = Peak
5. Trace mode = max hold
6. Sweep = auto couple
7. Allow the trace to stabilize
8. Measure the maximum width of the emission that is constrained by the frequencies associated with the two outermost amplitude points (upper and lower frequencies) that are attenuated by 20 dB relative to the maximum level measured in the fundamental emission.

6.2.4. Test Setup

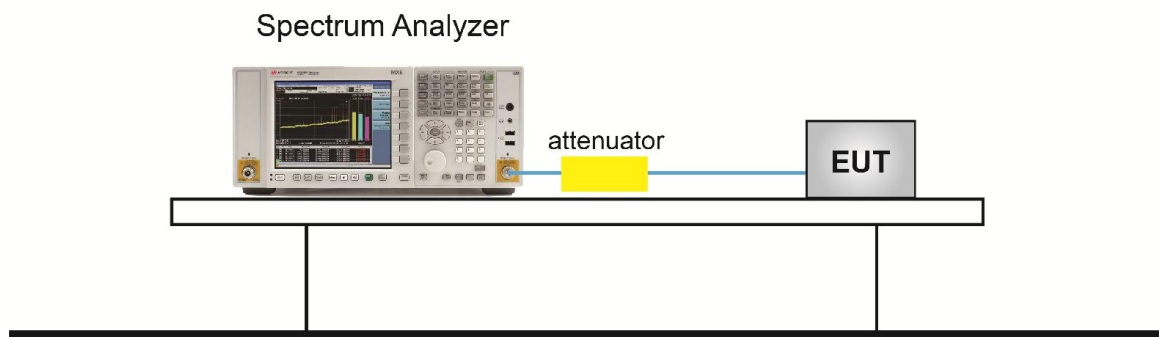

6.2.5. Test Result

Product	Communication Module	Temperature	25°C
Test Engineer	Dandy Li	Relative Humidity	52%
Test Site	TR3	Test Date	2019/03/07

Test Mode	Channel No.	Frequency (MHz)	20dB Bandwidth (kHz)	99% Bandwidth (kHz)	Result
DH5	00	2402	944.9	888.1	Pass
DH5	39	2441	946.4	888.6	Pass
DH5	78	2480	944.8	886.5	Pass
2DH5	00	2402	1342.0	1191.6	Pass
2DH5	39	2441	1344.0	1192.5	Pass
2DH5	78	2480	1347.0	1196.0	Pass
3DH5	00	2402	1311.0	1199.3	Pass
3DH5	39	2441	1310.0	1200.7	Pass
3DH5	78	2480	1207.2	1207.2	Pass

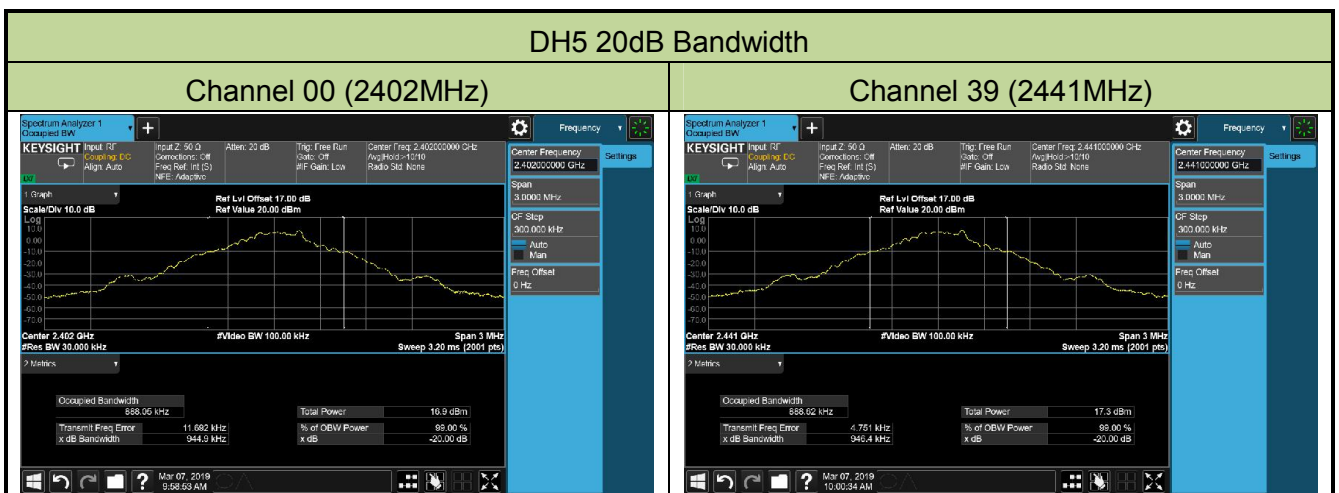

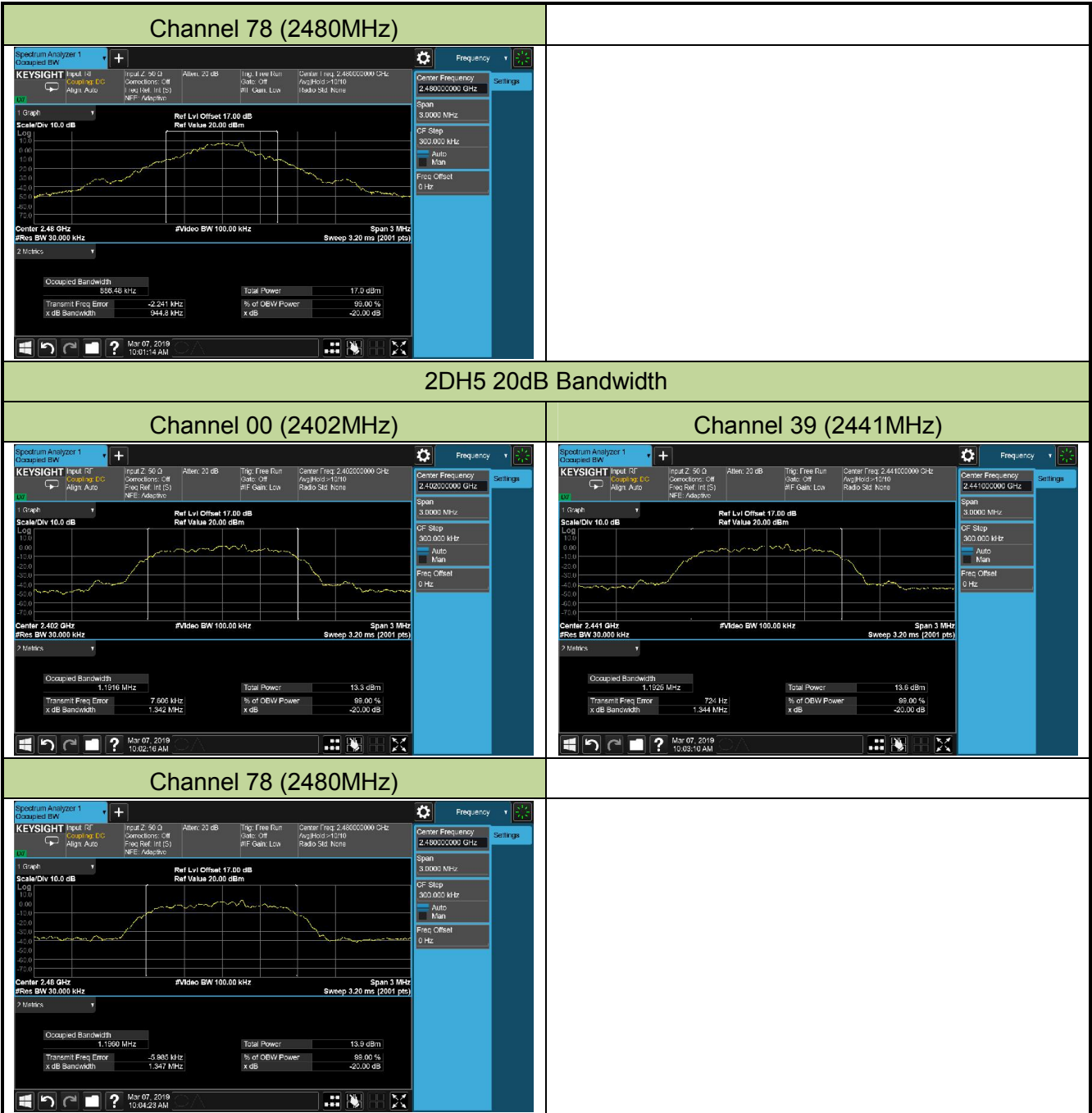

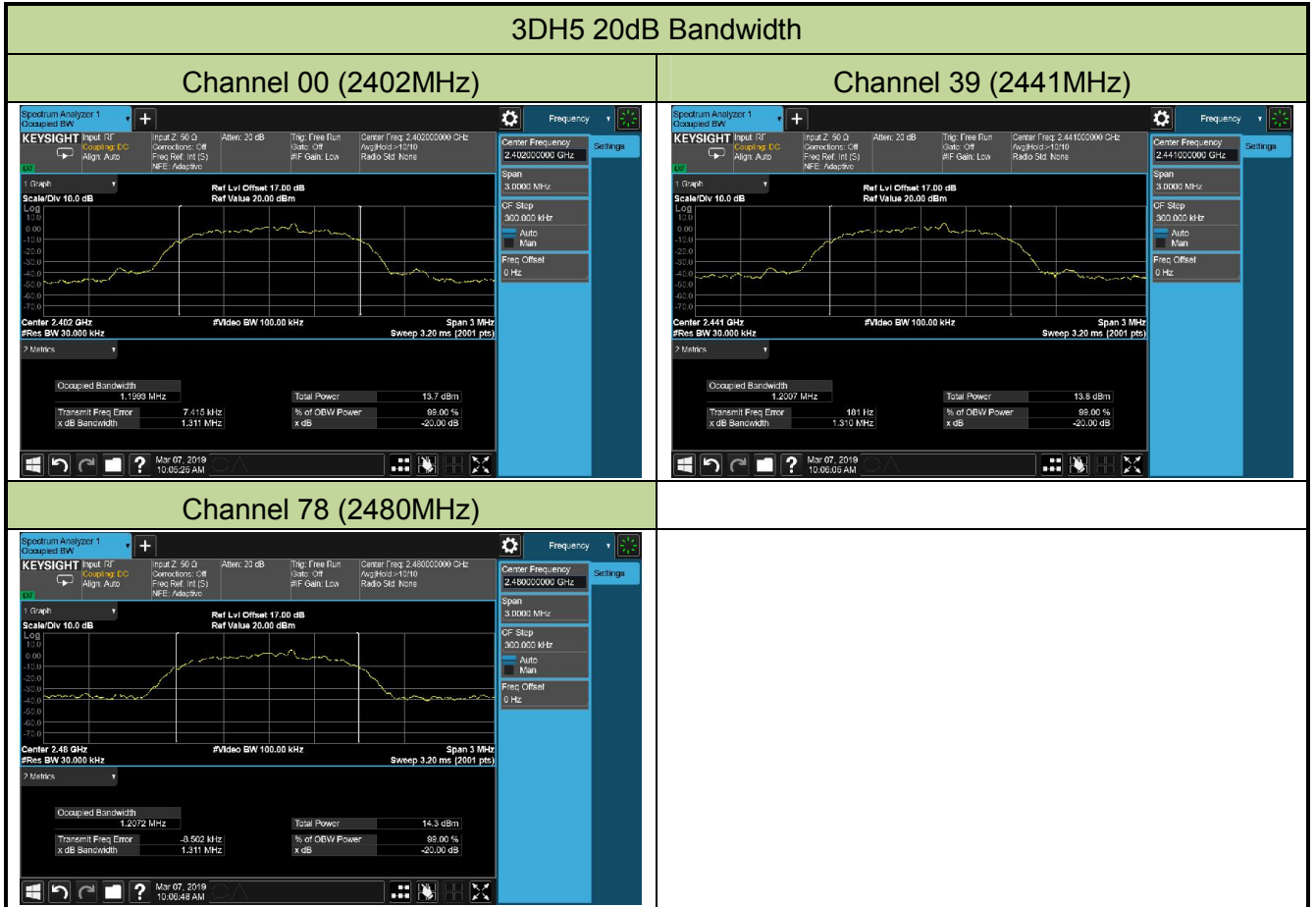

6.3. Output Power Measurement

6.3.1. Test Limit

For frequency hopping systems operating in the 2400-2483.5MHz band employing at least 75 non-overlapping hopping channels: 1watt. For all other frequency hopping systems in the 2400-2483.5MHz band: 0.125 watts.

The e.i.r.p. shall not exceed 4 W

6.3.2. Test Procedure Used

ANSI C63.10-2013 - Section 7.8.5

6.3.3. Test Setting

1. Set RBW \geq the 20 dB bandwidth of the emission being measured.
2. VBW $\geq 3 \times$ RBW
3. Span = approximately 2 to 3 times the 20dB bandwidth, centered on a hopping channel
4. Detector = Peak
5. Trace mode = max hold
6. Sweep = auto couple
7. Allow the trace to stabilize, Use the marker-to-peak function to set the marker to the peak of the emission. The indicated level is the peak output power (don't forget added the external attenuation and cable loss)

6.3.4. Test Setup

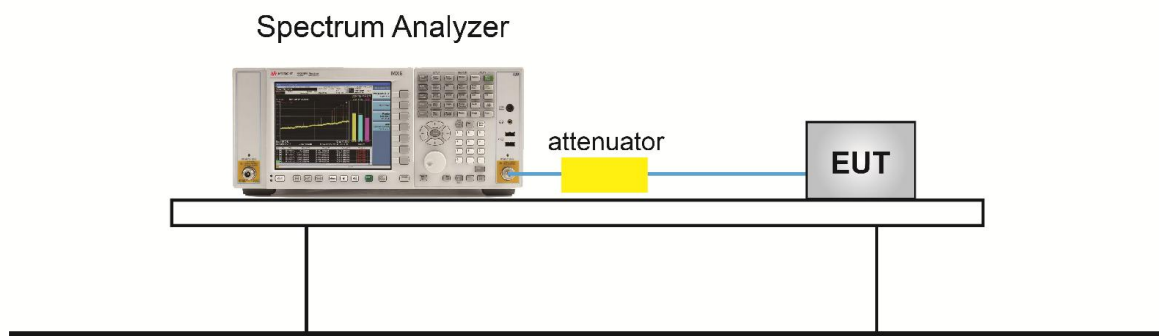

6.3.5. Test Result

Product	Communication Module	Temperature	25°C
Test Engineer	Dandy Li	Relative Humidity	52%
Test Site	TR3	Test Date	2019/03/07

Test Mode	Channel No.	Frequency (MHz)	Peak Power (dBm)	Peak Power Limit (dBm)	EIRP (dBm)	EIRP Limit (dBm)	Result
DH5	00	2402	9.59	≤ 20.97	10.49	≤ 36.0	Pass
DH5	39	2441	9.93	≤ 20.97	10.83	≤ 36.0	Pass
DH5	78	2480	9.50	≤ 20.97	10.40	≤ 36.0	Pass
2DH5	00	2402	7.75	≤ 20.97	8.65	≤ 36.0	Pass
2DH5	39	2441	7.76	≤ 20.97	8.66	≤ 36.0	Pass
2DH5	78	2480	8.05	≤ 20.97	8.95	≤ 36.0	Pass
3DH5	00	2402	8.24	≤ 20.97	9.14	≤ 36.0	Pass
3DH5	39	2441	8.20	≤ 20.97	9.10	≤ 36.0	Pass
3DH5	78	2480	8.45	≤ 20.97	9.35	≤ 36.0	Pass

Note: EIRP (dBm) = Peak Power (dBm) + Antenna Gain (dBi), Antenna Gain = 0.9 dBi.

DH5 Output Power

Channel 00 (2402MHz)



Channel 39 (2441MHz)



Channel 78 (2480MHz)



2DH5 Output Power

Channel 00 (2402MHz)



Channel 39 (2441MHz)



Channel 78 (2480MHz)



3DH5 Output Power

Channel 00 (2402MHz)



Channel 39 (2441MHz)



Channel 78 (2480MHz)



6.4. Carrier Frequency Separation Measurement

6.4.1. Test Limit

The minimum permissible channel separation for this system is $2/3$ the value of the 20dB BW.

6.4.2. Test Procedure Used

ANSI C63.10-2013 - Section 7.8.2

6.4.3. Test Setting

1. Span = wide enough to capture the peaks of two adjacent channels.
2. RBW $\geq 1\%$ of the span
3. VBW \geq RBW
4. Detector = peak
5. Sweep time = auto couple
6. Trace mode = max hold
7. Trace was allowed to stabilize

6.4.4. Test Setup

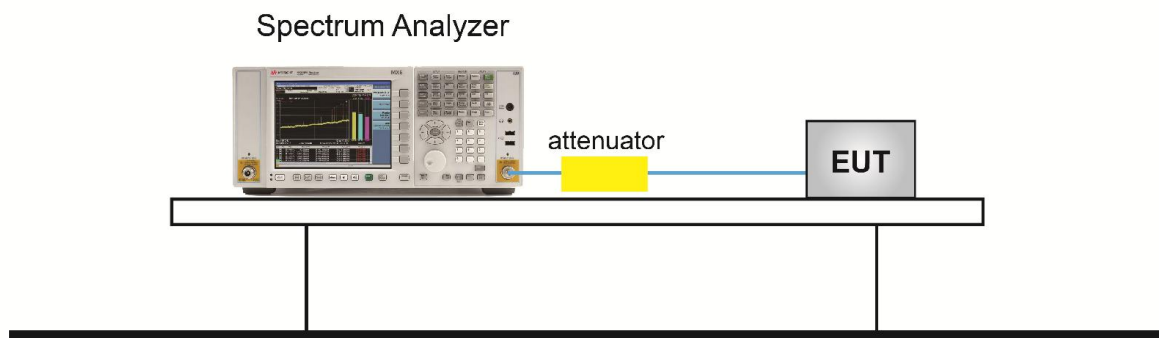

6.4.5. Test Result

Product	Communication Module	Temperature	25°C
Test Engineer	Dandy Li	Relative Humidity	52%
Test Site	TR3	Test Date	2019/03/07

Test Mode	Channel No.	Frequency (MHz)	Limit (kHz)	Result
DH5	00	2402	≥ 629.93	Pass
DH5	39	2441	≥ 630.93	Pass
DH5	78	2480	≥ 629.87	Pass
2DH5	00	2402	≥ 894.67	Pass
2DH5	39	2441	≥ 896.00	Pass
2DH5	78	2480	≥ 898.00	Pass
3DH5	00	2402	≥ 874.00	Pass
3DH5	39	2441	≥ 873.33	Pass
3DH5	78	2480	≥ 804.80	Pass

Note: The Limit is 2/3 the value of the 20dB BW.

DH5 Carrier Frequency Separation

Channel 00 (2402MHz)

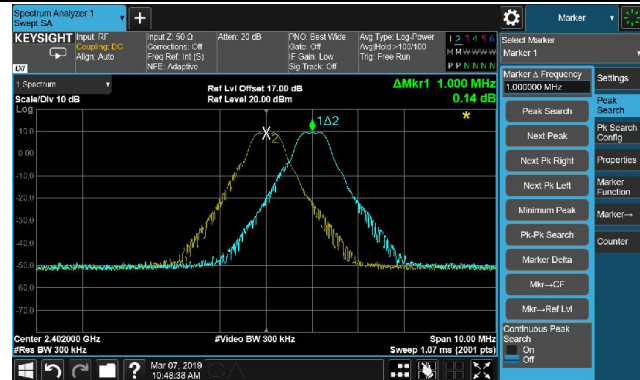

Channel 39 (2441MHz)

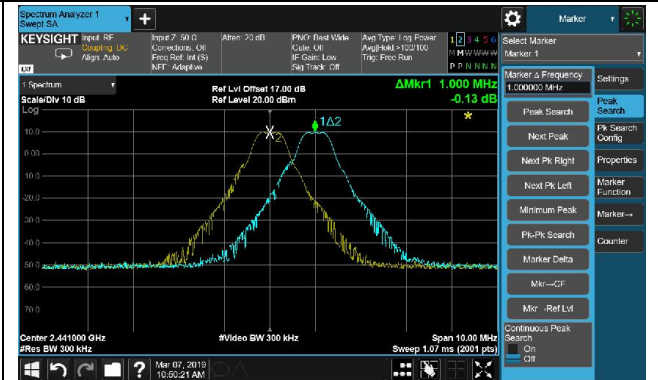

Channel 78 (2480MHz)



2DH5 Carrier Frequency Separation

Channel 00 (2402MHz)

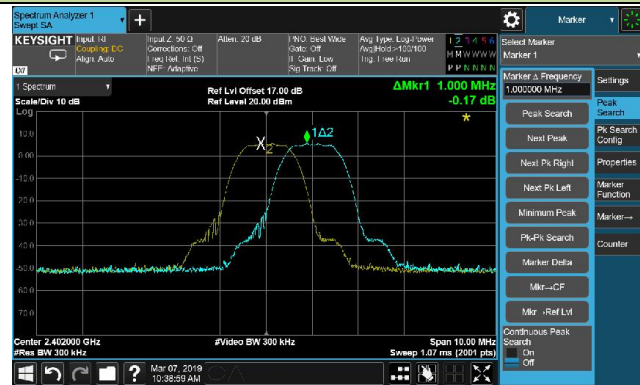

Channel 39 (2441MHz)

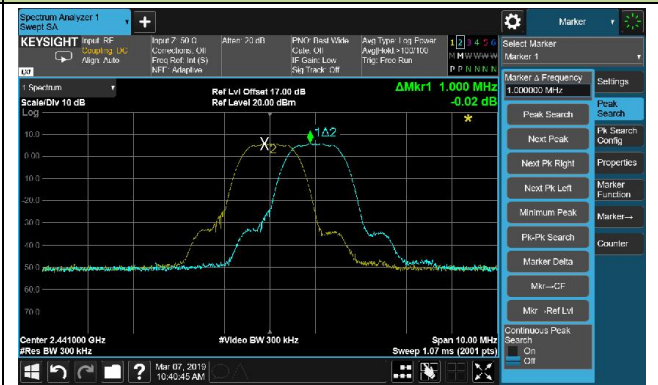

Channel 78 (2480MHz)



3DH5 Carrier Frequency Separation

Channel 00 (2402MHz)



Channel 39 (2441MHz)



Channel 78 (2480MHz)



6.5. Number of Hopping Channels Measurement

6.5.1. Test Limit

This frequency hopping system must employ a minimum of 15 hopping channels.

6.5.2. Test Procedure Used

ANSI C63.10-2013 - Section 7.8.3

6.5.3. Test Setting

1. Span = the frequency band of operation.
2. RBW \geq 1 % of the span
3. VBW \geq RBW
4. Detector = Peak
5. Trace mode = max hold
6. Sweep time = auto couple
7. The trace was allowed to stabilize

6.5.4. Test Setup

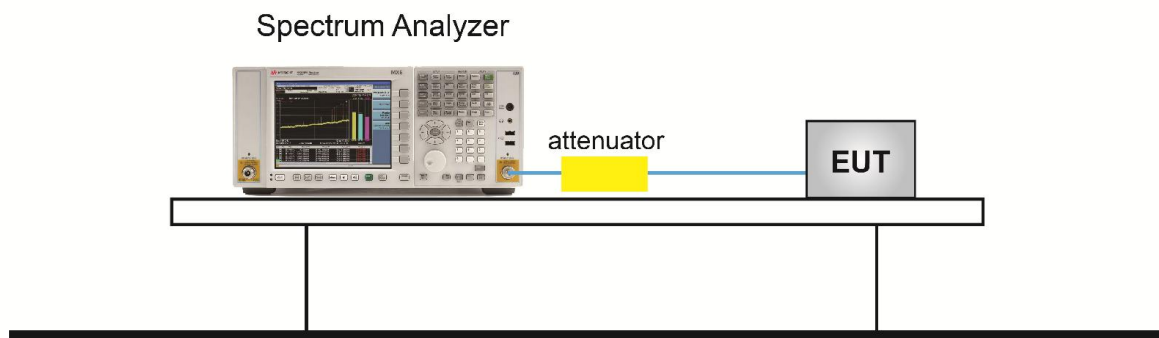

6.5.5. Test Result

Product	Communication Module	Temperature	25°C
Test Engineer	Dandy Li	Relative Humidity	52%
Test Site	TR3	Test Date	2019/09/07

Test Mode (Hopping)	Channel Numbers	Frequency (MHz)	Limit (Hopping Channels)	Result
DH5	79	2402~2480	≥ 15	Pass
2DH5	79	2402~2480	≥ 15	Pass
3DH5	79	2402~2480	≥ 15	Pass

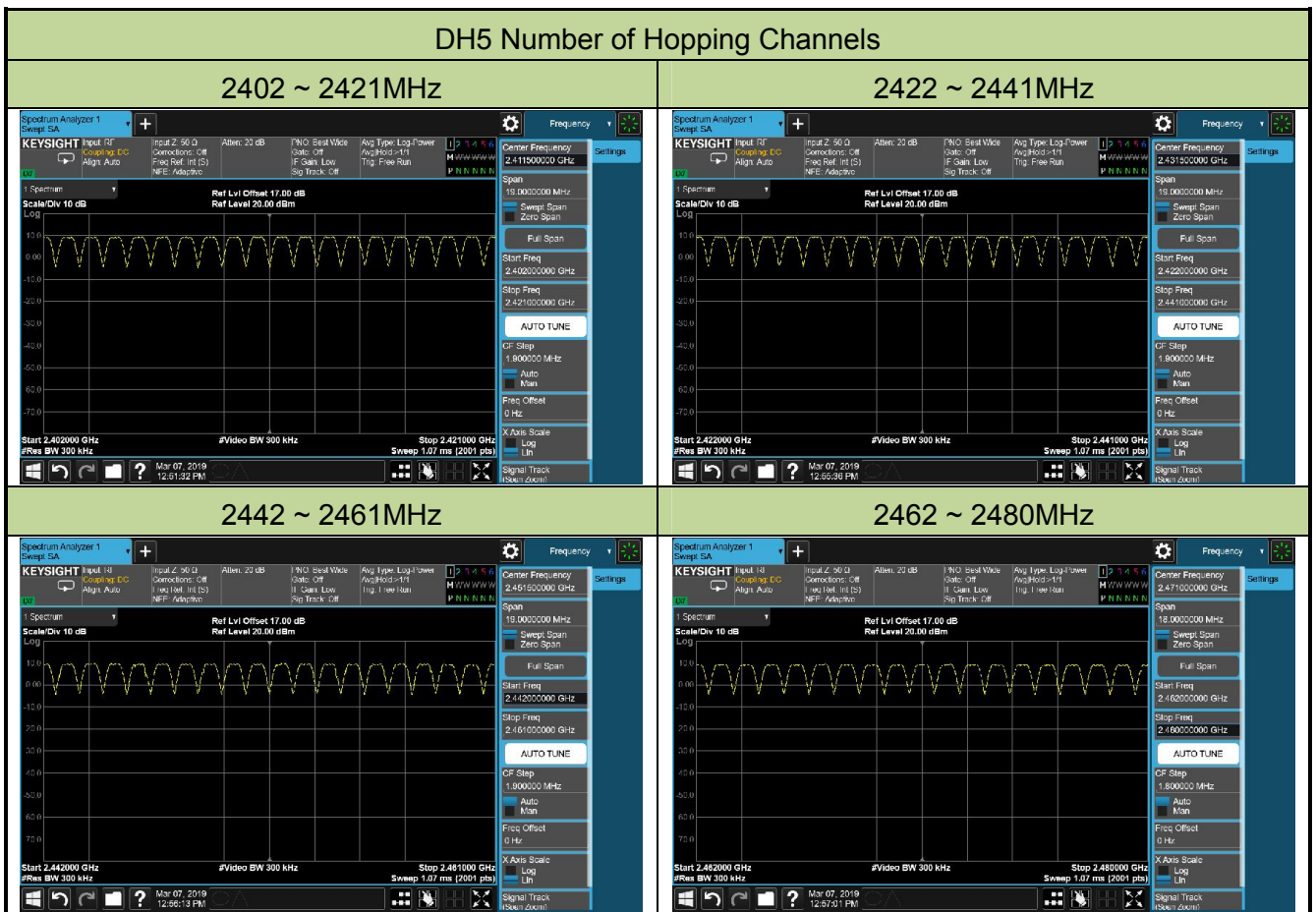

2DH5 Number of Hopping Channels

2402 ~ 2421MHz

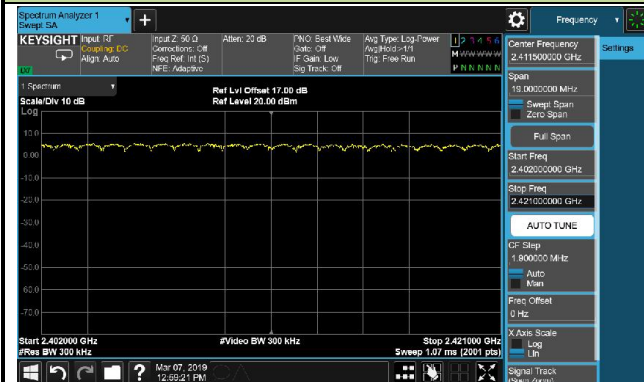

2422 ~ 2441MHz

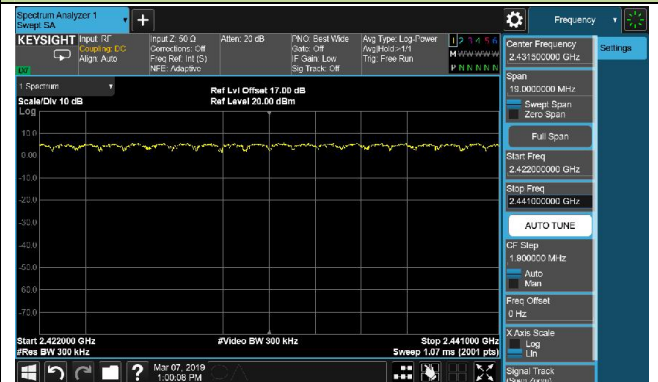

2442 ~ 2461MHz



2462 ~ 2480MHz



3DH5 Number of Hopping Channels

2402 ~ 2421MHz

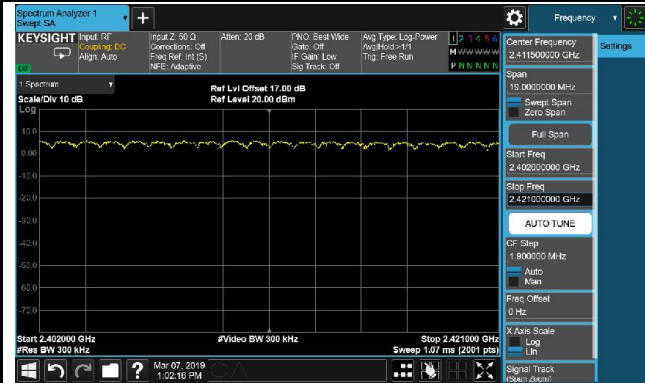

2422 ~ 2441MHz

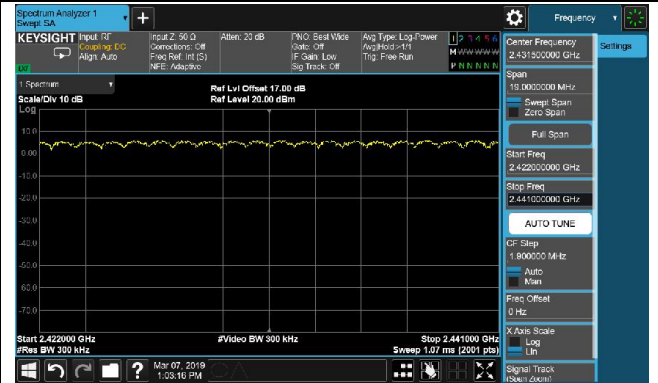

2442 ~ 2461MHz

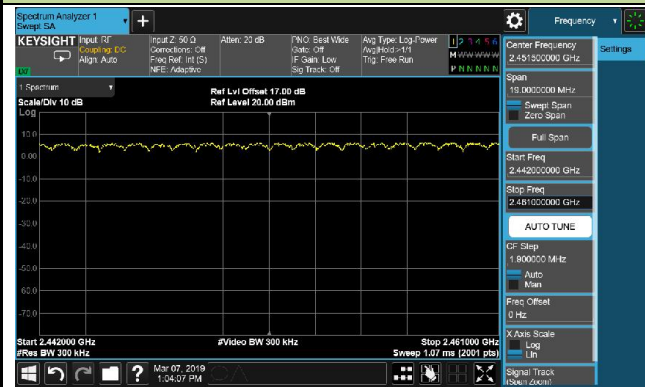

2462 ~ 2480MHz



6.6. Time of Occupancy Measurement

6.6.1. Test Limit

The maximum permissible time of occupancy is 400ms within a period of 400ms multiplied by the number of hopping channels employed.

6.6.2. Test Procedure Used

ANSI C63.10-2013 - Section 7.8.4

6.6.3. Test Setting

1. Span = zero span, centered on a hopping channel.
2. RBW = 1MHz
3. VBW \geq RBW
4. Sweep time = as necessary to capture the entire dwell time per hopping channel
5. Detector = Peak
6. Trace mode = max hold
7. If possible, use the marker-delta function to determine the dwell time. If this value varies with different modes of operation (data rate, modulation format, etc.), repeat this test for each variation. An oscilloscope may be used instead of a spectrum analyzer. The EUT shall show compliance with the appropriate regulatory limit for the number of hopping channels. A plot of the data shall be included in the test report.

6.6.4. Test Setup

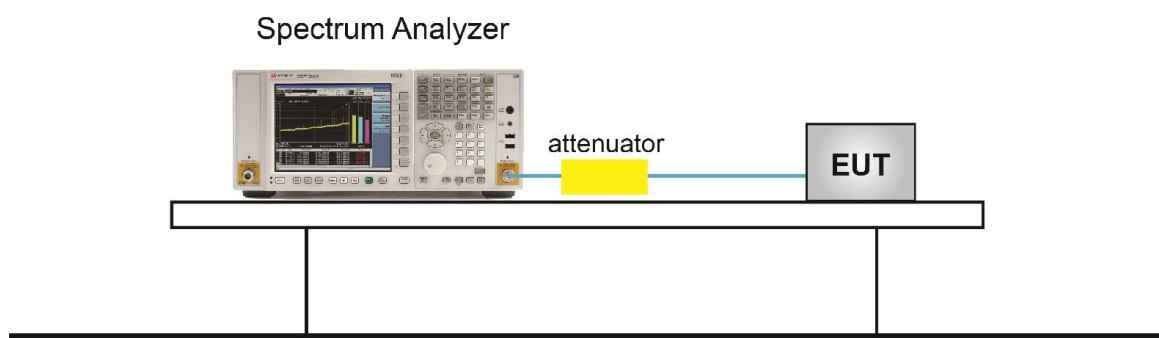

6.6.5. Test Result

Product	Communication Module	Temperature	25°C
Test Engineer	Dandy Li	Relative Humidity	52%
Test Site	TR3	Test Date	2019/03/07

Test Mode	Channel No.	Frequency (MHz)	Hops Over Occupancy Time(Hops)	Packet Transfer Time (ms)	Time of Occupancy (ms)	Limit (ms)	Result
3DH1	39	2441	320	0.38	121.6	< 400	Pass
3DH3	39	2441	160	1.64	262.4	< 400	Pass
3DH5	39	2441	107	2.88	308.2	< 400	Pass

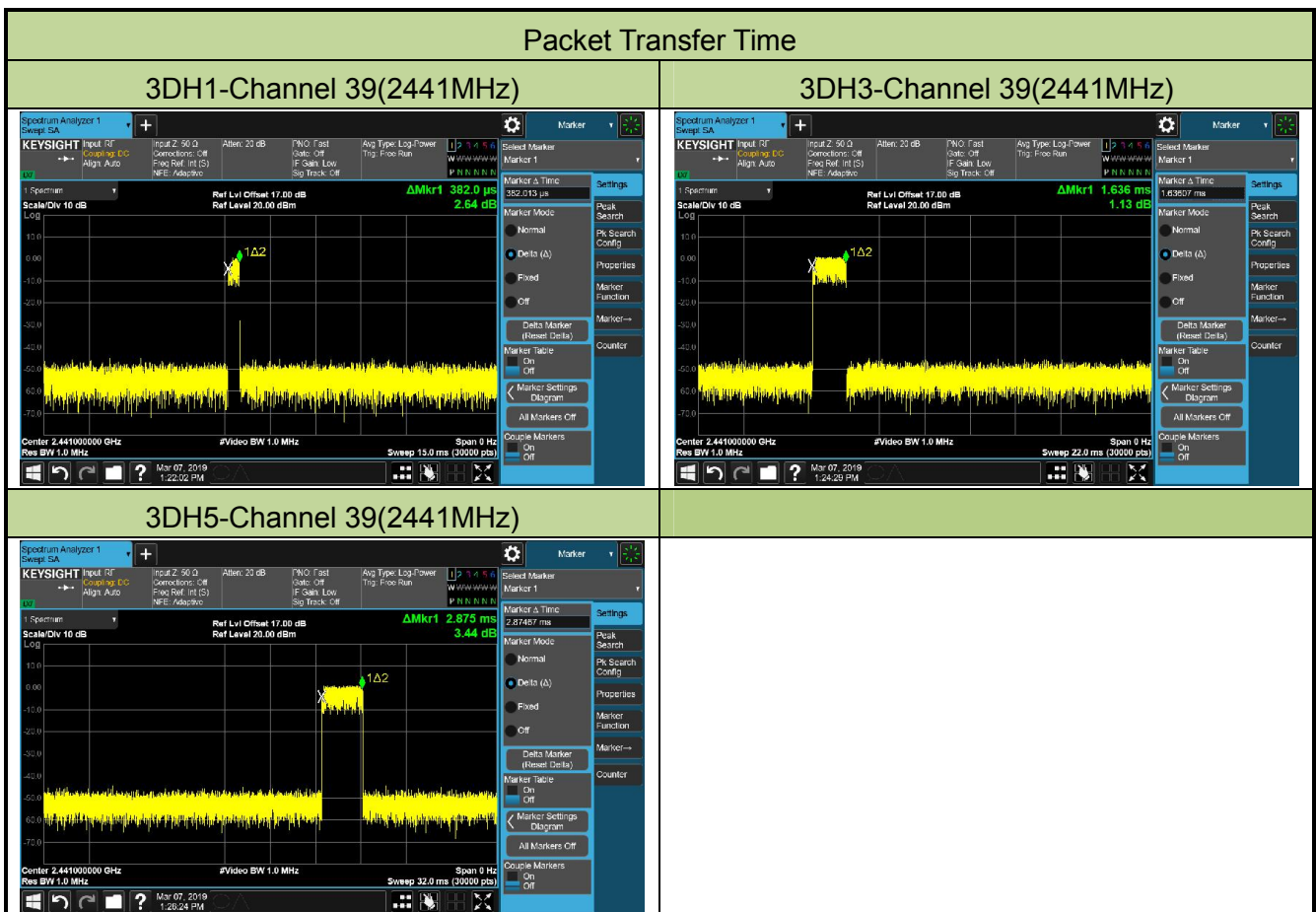

Note 1: According the Bluetooth Standard Specification, the nominal hop rate is 1600 hops/s. All

Bluetooth unit participating in the piconet are time and hop synchronized to the channel.

Hops Over Occupancy Time in 31.6s for 3DH1 = $1600 / 2 / 79 * 31.6 = 320$.

Hops Over Occupancy Time in 31.6s for 3DH3 = $1600 / 4 / 79 * 31.6 = 160$.

Hops Over Occupancy Time in 31.6s for 3DH5 = $1600 / 6 / 79 * 31.6 = 107$.

Note 2: Time of Occupancy = Packet Transfer Time * Hops Over Occupancy Time in 31.6s.

6.7. Band-edge Compliance Measurement

6.7.1. Test Limit

The maximum permissible emission level is 20dBc. Any emissions were lying outside of the emission bandwidth and in authorized band edges to a field strength limit specified in Section 15.209 of the Title 47 CFR.

6.7.2. Test Procedure Used

ANSI C63.10-2013 - Section 6.10.4

6.7.3. Test Setting

1. Span = wide enough to capture the peak level of the emission operating on the channel closest to the band edge, as well as any modulation products which fall outside of the authorized band of operation.
2. RBW \geq 1% of spectrum analyzer display span
3. VBW \geq RBW
4. Detector = peak
5. Sweep time = auto couple
6. Trace mode = max hold
7. Trace was allowed to stabilize
8. Allow the trace to stabilize. Set the marker on the emission at the band edge, or on the highest modulation product outside of the band, if this level is greater than that at the band edge. Enable the marker-delta function, then use the marker-to-peak function to move the marker to the peak of the in-band emission.

6.7.4. Test Setup

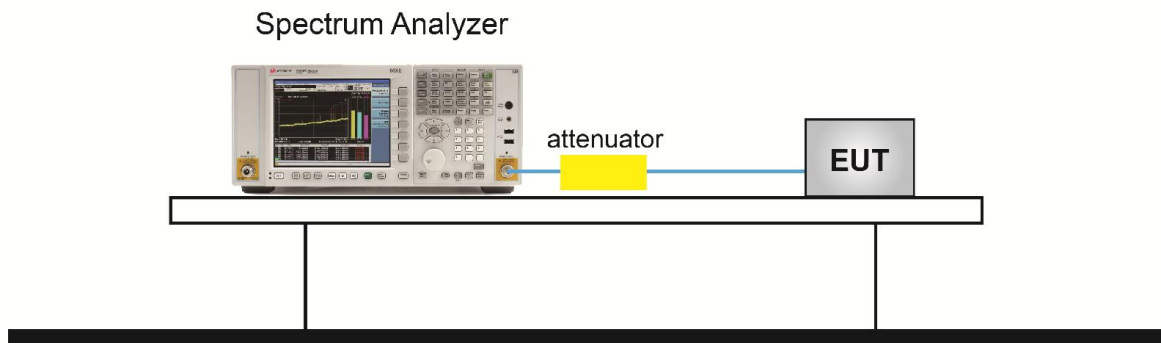

6.7.5. Test Result

Product	Communication Module	Temperature	25°C
Test Engineer	Dandy Li	Relative Humidity	52%
Test Site	TR3	Test Date	2019/03/07

Test Mode	Channel No.	Frequency (MHz)	Limit	Result
DH5	00	2402	20dBc	Pass
DH5	78	2480	20dBc	Pass
2DH5	00	2402	20dBc	Pass
2DH5	78	2480	20dBc	Pass
3DH5	00	2402	20dBc	Pass
3DH5	78	2480	20dBc	Pass

DH5 Band-edge Compliance

Channel 00 (2402MHz)



Channel 78 (2480MHz)



2DH5 Band-edge Compliance

Channel 00 (2402MHz)



Channel 78 (2480MHz)



3DH5 Band-edge Compliance

Channel 00 (2402MHz)



Channel 78 (2480MHz)



DH5 Operation Frequency Range of 20dB Bandwidth within Hopping Mode

Channel 00 (2402MHz)



Channel 78 (2480MHz)

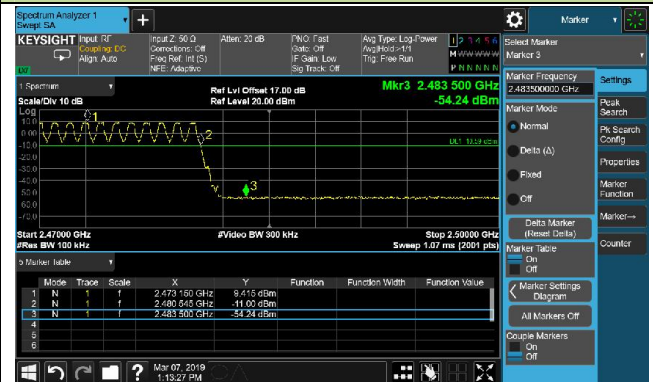

2DH5 Operation Frequency Range of 20dB Bandwidth within Hopping Mode

Channel 00 (2402MHz)



Channel 78 (2480MHz)



DH5 Operation Frequency Range of 20dB Bandwidth within Hopping Mode

Channel 00 (2402MHz)



Channel 78 (2480MHz)

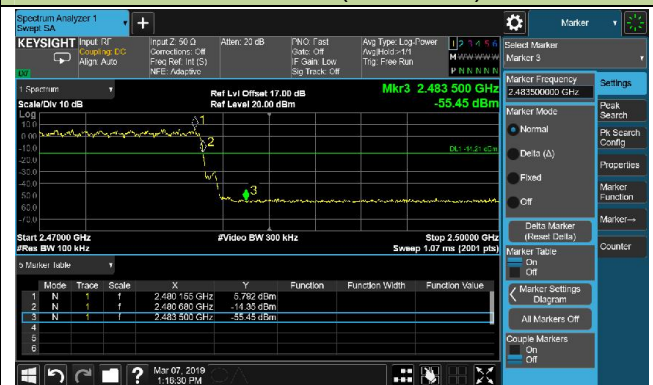

6.8. Conducted Spurious Emissions Measurement

6.8.1. Test Limit

In any 100 kHz bandwidth outside the frequency band in which the spread spectrum or digitally modulated intentional radiator is operating, the radio frequency power that is produced by the intentional radiator shall be at least 20 dB below that in the 100 kHz bandwidth within the band that contains the highest level of the desired power, based on either an RF conducted or a radiated measurement, provided the transmitter demonstrates compliance with the peak conducted or a radiated measurement, provided the transmitter demonstrates compliance with the peak conducted power limits. If the transmitter complies with the conducted power limits based on the use of RMS averaging over a time interval, the attenuation required under this paragraph shall be 30 dB instead of 20 dB.

6.8.2. Test Procedure Used

ANSI C63.10-2013 - Section 7.8.8

6.8.3. Test Setting

1. Span = wide enough to capture the peak level of the in-band emission and all spurious emissions (e.g., harmonics) from the lowest frequency generated in the EUT up through the 10th harmonic. Typically, several plots are required to cover this entire span.
2. RBW = 100 KHz
3. VBW \geq RBW
4. Detector = peak
5. Sweep time = auto couple
6. Trace mode = max hold
7. Trace was allowed to stabilize
8. Set the marker on the peak of any spurious emission recorded. The level displayed must comply with the limit specified in this section.

6.8.4. Test Setup

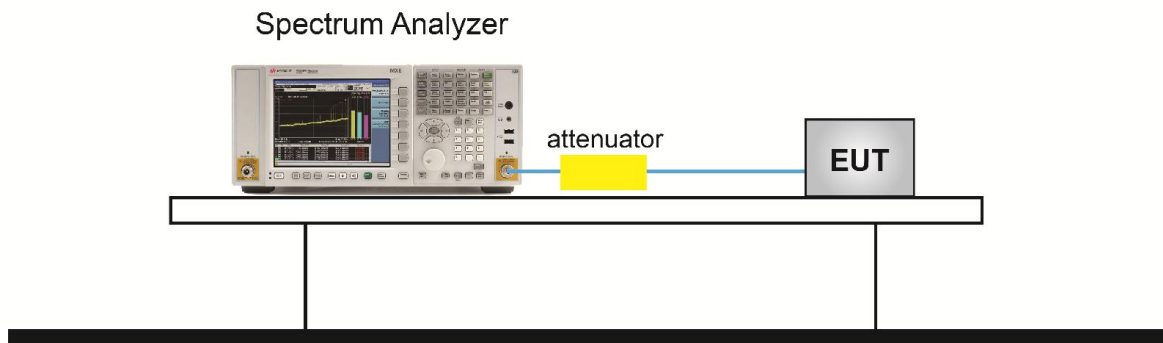

6.8.5. Test Result

Product	Communication Module	Temperature	25°C
Test Engineer	Dandy Li	Relative Humidity	52%
Test Site	TR3	Test Date	2019/03/07

Test Mode	Channel No.	Frequency (MHz)	Limit (MHz)	Result
DH5	00	2402	20dBc	Pass
DH5	39	2441	20dBc	Pass
DH5	78	2480	20dBc	Pass
2DH5	00	2402	20dBc	Pass
2DH5	39	2441	20dBc	Pass
2DH5	78	2480	20dBc	Pass
3DH5	00	2402	20dBc	Pass
3DH5	39	2441	20dBc	Pass
3DH5	78	2480	20dBc	Pass

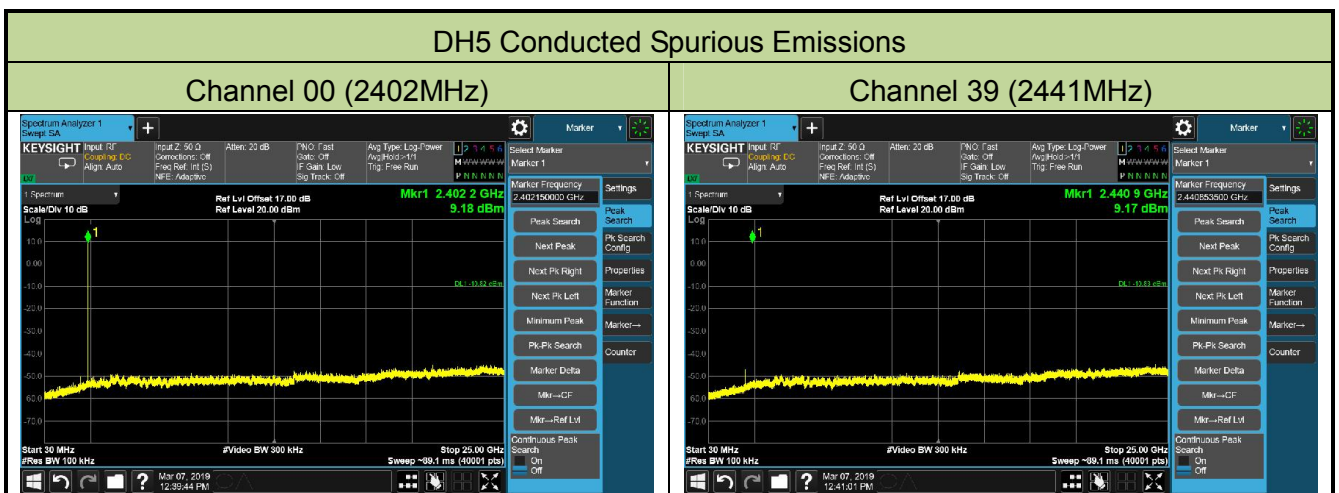

Channel 78 (2480MHz)



2DH5 Conducted Spurious Emissions

Channel 00 (2402MHz)

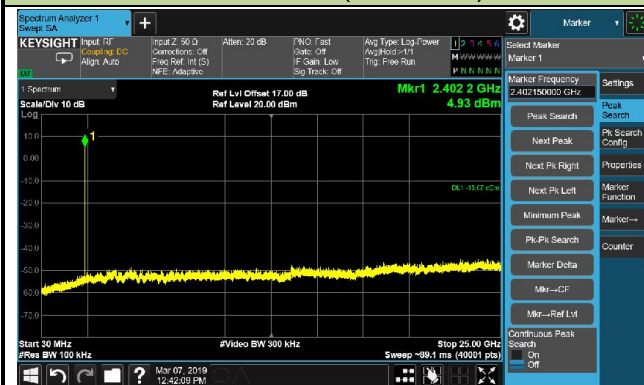

Channel 39 (2441MHz)

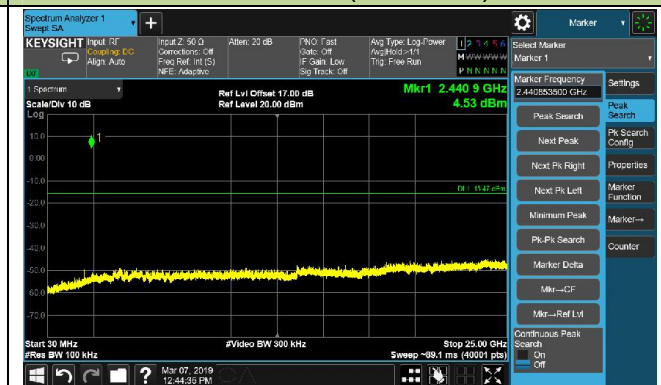

Channel 78 (2480MHz)

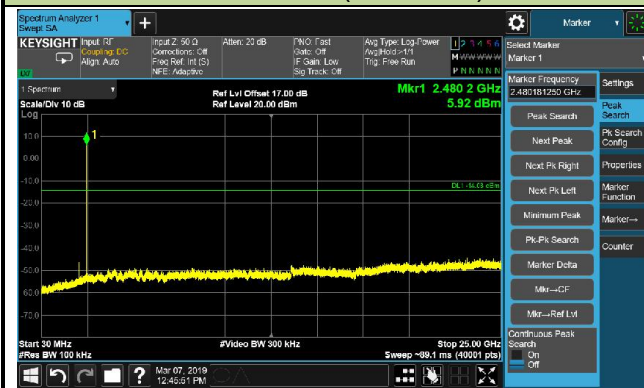

3DH5 Conducted Spurious Emissions

Channel 00 (2402MHz)

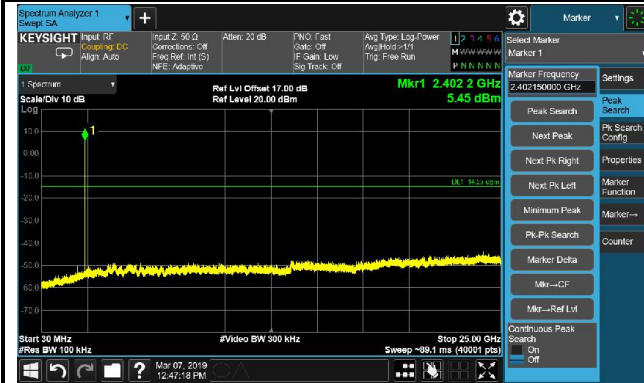

Channel 39 (2441MHz)



Channel 78 (2480MHz)



6.9. Radiated Spurious Emission Measurement

6.9.1. Test Limit

All out of band emissions appearing in a restricted band as specified in Section 15.205 of the Title 47 CFR must not exceed the limits shown in Table per Section 15.209.

FCC Part 15 Subpart C Paragraph 15.209		
Frequency [MHz]	Field Strength [uV/m]	Measured Distance [Meters]
0.009 - 0.490	2400/F (kHz)	300
0.490 - 1.705	24000/F (kHz)	30
1.705 - 30	30	30
30 - 88	100	3
88 - 216	150	3
216 - 960	200	3
Above 960	500	3

6.9.2. Test Procedure Used

ANSI C63.10 Section 6.3 (General Requirements)

ANSI C63.10 Section 6.4 (Standard test method below 30MHz)

ANSI C63.10 Section 6.5 (Standard test method above 30MHz to 1GHz)

ANSI C63.10 Section 6.6 (Standard test method above 1GHz)

6.9.3. Test Setting

Table 1 - RBW as a function of frequency

Frequency	RBW
9 ~ 150 kHz	200 ~ 300 Hz
0.15 ~ 30 MHz	9 ~ 10 kHz
30 ~ 1000 MHz	100 ~ 120 kHz
> 1000 MHz	1 MHz

Quasi-Peak Measurements below 1GHz

1. Analyzer center frequency was set to the frequency of the radiated spurious emission of interest
2. Span was set greater than 1MHz
3. RBW = as specified in Table 1
4. Detector = CISPR quasi-peak
5. Sweep time = auto couple
6. Trace was allowed to stabilize

Peak Measurements above 1GHz

1. Analyzer center frequency was set to the frequency of the radiated spurious emission of interest
2. RBW = 1MHz
3. VBW = 3MHz
4. Detector = peak
5. Sweep time = auto couple
6. Trace mode = max hold
7. Trace was allowed to stabilize

Average Measurements above 1GHz (Method VB)

1. Analyzer center frequency was set to the frequency of the radiated spurious emission of interest
2. RBW = 1MHz
3. VBW; If the EUT is configured to transmit with duty cycle $\geq 98\%$, set VBW = 10 Hz.

If the EUT duty cycle is $< 98\%$, set VBW $\geq 1/T$. T is the minimum transmission duration.
4. Detector = Peak
5. Sweep time = auto
6. Trace mode = max hold
7. Trace was allowed to stabilize

6.9.4. Test Setup

Below 1GHz Test Setup:

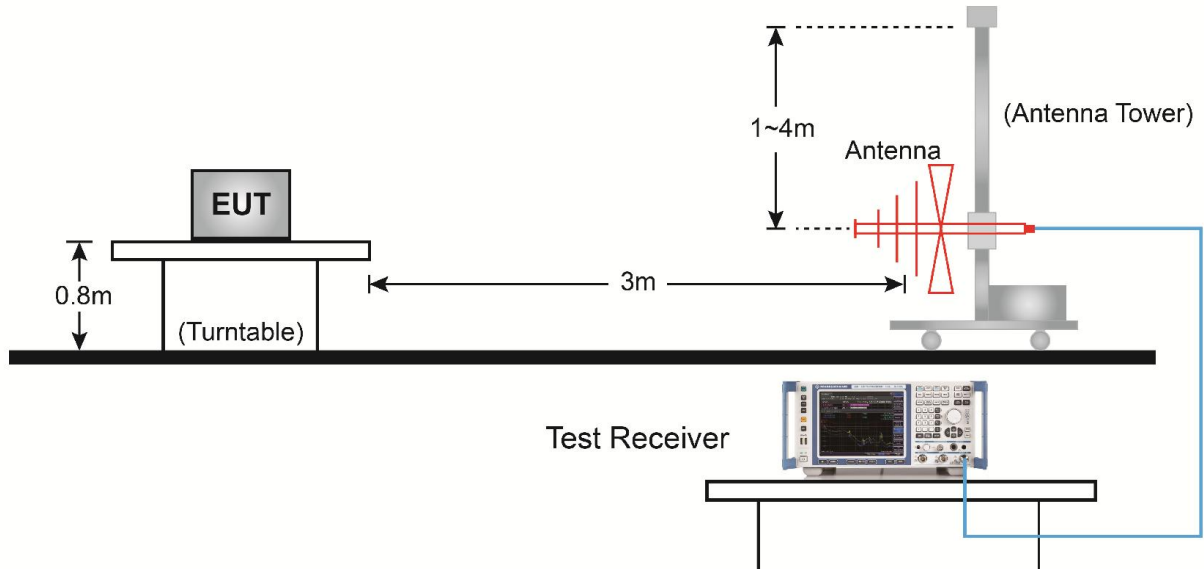

Above 1GHz Test Setup:

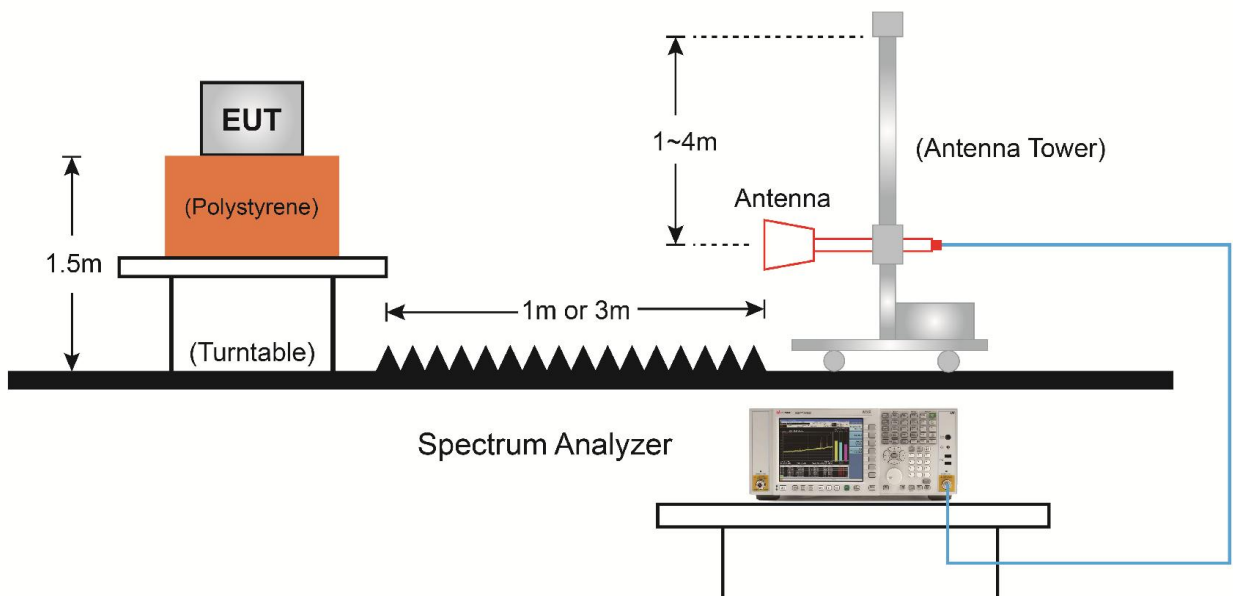

6.9.5. Test Result

Product	Communication Module	Temperature	26°C
Test Engineer	Messiah Li	Relative Humidity	56%
Test Site	AC1	Test Date	2019/03/02
Test Mode:	DH5	Test Channel:	00
Remark:	1. Average measurement was not performed if peak level lower than average limit. 2. Other frequency was 20dB below limit line within 1-18GHz, there is not show in the report.		

Mark	Frequency (MHz)	Reading Level (dBμV)	Factor (dB)	Measure Level (dBμV/m)	Limit (dBμV/m)	Margin (dB)	Detector	Polarization
	4808.0	37.9	5.9	43.8	74.0	-30.2	Peak	Horizontal
	7451.5	36.8	12.9	49.7	74.0	-24.3	Peak	Horizontal
*	9942.0	35.0	16.8	51.8	82.8	-31.0	Peak	Horizontal
*	10375.5	34.6	17.4	52.0	82.8	-30.8	Peak	Horizontal
	4255.5	37.6	4.2	41.8	74.0	-32.2	Peak	Vertical
	4978.0	36.8	6.2	43.0	74.0	-31.0	Peak	Vertical
*	6601.5	36.2	10.2	46.4	82.8	-36.4	Peak	Vertical
*	9993.0	34.5	16.7	51.2	82.8	-31.6	Peak	Vertical

Note 1: "*" is not in restricted band, its limit is 20dBc of the fundamental emission level (102.8dBμV/m) or 15.209 which is higher.

Note 2: Measure Level (dBμV/m) = Reading Level (dBμV) + Factor (dB)

Factor (dB) = Cable Loss (dB) + Antenna Factor (dB/m) - Pre_Amplifier Gain (dB)

Product	Communication Module	Temperature	26°C
Test Engineer	Messiah Li	Relative Humidity	56%
Test Site	AC1	Test Date	2019/03/02
Test Mode:	DH5	Test Channel:	39
Remark:	1. Average measurement was not performed if peak level lower than average limit. 2. Other frequency was 20dB below limit line within 1-18GHz, there is not show in the report.		

Mark	Frequency (MHz)	Reading Level (dBμV)	Factor (dB)	Measure Level (dBμV/m)	Limit (dBμV/m)	Margin (dB)	Detector	Polarization
	4221.5	38.4	4.1	42.5	74.0	-31.5	Peak	Horizontal
	4808.0	37.6	5.9	43.5	74.0	-30.5	Peak	Horizontal
*	6542.0	35.8	10.1	45.9	83.0	-37.1	Peak	Horizontal
*	10154.5	34.7	17.0	51.7	83.0	-31.3	Peak	Horizontal
	4094.0	39.3	3.6	42.9	74.0	-31.1	Peak	Vertical
	4995.0	36.7	6.3	43.0	74.0	-31.0	Peak	Vertical
*	6074.5	36.5	8.0	44.5	83.0	-38.5	Peak	Vertical
*	9967.5	34.7	16.7	51.4	83.0	-31.6	Peak	Vertical

Note 1: "*" is not in restricted band, its limit is 20dBc of the fundamental emission level (103.0dBμV/m) or 15.209 which is higher.

Note 2: Measure Level (dBμV/m) = Reading Level (dBμV) + Factor (dB)

Factor (dB) = Cable Loss (dB) + Antenna Factor (dB/m) - Pre_Amplifier Gain (dB)

Product	Communication Module	Temperature	26°C
Test Engineer	Messiah Li	Relative Humidity	56%
Test Site	AC1	Test Date	2019/03/02
Test Mode:	DH5	Test Channel:	78
Remark:	1. Average measurement was not performed if peak level lower than average limit. 2. Other frequency was 20dB below limit line within 1-18GHz, there is not show in the report.		

Mark	Frequency (MHz)	Reading Level (dBμV)	Factor (dB)	Measure Level (dBμV/m)	Limit (dBμV/m)	Margin (dB)	Detector	Polarization
	4136.5	38.5	3.8	42.3	74.0	-31.7	Peak	Horizontal
	5063.0	36.8	6.5	43.3	74.0	-30.7	Peak	Horizontal
*	6567.5	36.2	10.2	46.4	81.6	-35.2	Peak	Horizontal
*	10018.5	35.0	16.6	51.6	81.6	-30.0	Peak	Horizontal
	4000.5	38.1	3.3	41.4	74.0	-32.6	Peak	Vertical
	5063.0	36.5	6.5	43.0	74.0	-31.0	Peak	Vertical
*	6516.5	35.9	9.9	45.8	81.6	-35.8	Peak	Vertical
*	10333.0	35.7	17.3	53.0	81.6	-28.6	Peak	Vertical

Note 1: "*" is not in restricted band, its limit is 20dBc of the fundamental emission level 101.6dBμV/m) or 15.209 which is higher.

Note 2: Measure Level (dBμV/m) = Reading Level (dBμV) + Factor (dB)

Factor (dB) = Cable Loss (dB) + Antenna Factor (dB/m) - Pre_Amplifier Gain (dB)

Product	Communication Module	Temperature	26°C
Test Engineer	Messiah Li	Relative Humidity	56%
Test Site	AC1	Test Date	2019/03/02
Test Mode:	2DH5	Test Channel:	00
Remark:	1. Average measurement was not performed if peak level lower than average limit. 2. Other frequency was 20dB below limit line within 1-18GHz, there is not show in the report.		

Mark	Frequency (MHz)	Reading Level (dBμV)	Factor (dB)	Measure Level (dBμV/m)	Limit (dBμV/m)	Margin (dB)	Detector	Polarization
	4085.5	37.7	3.5	41.2	74.0	-32.8	Peak	Horizontal
	4663.5	36.6	5.4	42.0	74.0	-32.0	Peak	Horizontal
*	6244.5	37.2	8.6	45.8	80.6	-34.8	Peak	Horizontal
*	9984.5	34.7	16.7	51.4	80.6	-29.2	Peak	Horizontal
	4000.5	37.9	3.3	41.2	74.0	-32.8	Peak	Vertical
	4859.0	36.6	5.9	42.5	74.0	-31.5	Peak	Vertical
*	6389.0	36.1	9.2	45.3	80.6	-35.3	Peak	Vertical
*	10180.0	34.5	17.1	51.6	80.6	-29.0	Peak	Vertical

Note 1: "*" is not in restricted band, its limit is 20dBc of the fundamental emission level (100.6dBμV/m) or 15.209 which is higher.

Note 2: Measure Level (dBμV/m) = Reading Level (dBμV) + Factor (dB)

Factor (dB) = Cable Loss (dB) + Antenna Factor (dB/m) - Pre_Amplifier Gain (dB)

Product	Communication Module	Temperature	26°C
Test Engineer	Messiah Li	Relative Humidity	56%
Test Site	AC1	Test Date	2019/03/02
Test Mode:	2DH5	Test Channel:	39
Remark:	1. Average measurement was not performed if peak level lower than average limit. 2. Other frequency was 20dB below limit line within 1-18GHz, there is not show in the report.		

Mark	Frequency (MHz)	Reading Level (dBμV)	Factor (dB)	Measure Level (dBμV/m)	Limit (dBμV/m)	Margin (dB)	Detector	Polarization
	4060.0	38.0	3.5	41.5	74.0	-32.5	Peak	Horizontal
	4867.5	36.5	6.0	42.5	74.0	-31.5	Peak	Horizontal
*	6533.5	35.4	10.0	45.4	80.4	-35.0	Peak	Horizontal
*	10188.5	34.7	17.1	51.8	80.4	-28.6	Peak	Horizontal
	4111.0	37.6	3.7	41.3	74.0	-32.7	Peak	Vertical
	4910.0	36.6	6.1	42.7	74.0	-31.3	Peak	Vertical
*	6576.0	36.0	10.2	46.2	80.4	-34.2	Peak	Vertical
*	9976.0	34.7	16.7	51.4	80.4	-29.0	Peak	Vertical

Note 1: "*" is not in restricted band, its limit is 20dBc of the fundamental emission level (100.4dBμV/m) or 15.209 which is higher.

Note 2: Measure Level (dBμV/m) = Reading Level (dBμV) + Factor (dB)

Factor (dB) = Cable Loss (dB) + Antenna Factor (dB/m) - Pre_Amplifier Gain (dB)

Product	Communication Module	Temperature	26°C
Test Engineer	Messiah Li	Relative Humidity	56%
Test Site	AC1	Test Date	2019/03/02
Test Mode:	2DH5	Test Channel:	78
Remark:	1. Average measurement was not performed if peak level lower than average limit. 2. Other frequency was 20dB below limit line within 1-18GHz, there is not show in the report.		

Mark	Frequency (MHz)	Reading Level (dBμV)	Factor (dB)	Measure Level (dBμV/m)	Limit (dBμV/m)	Margin (dB)	Detector	Polarization
	3992.0	39.0	3.2	42.2	74.0	-31.8	Peak	Horizontal
	4680.5	36.6	5.4	42.0	74.0	-32.0	Peak	Horizontal
*	6610.0	36.2	10.2	46.4	79.7	-33.3	Peak	Horizontal
*	9950.5	34.4	16.7	51.1	79.7	-28.6	Peak	Horizontal
	3941.0	38.1	3.2	41.3	74.0	-32.7	Peak	Vertical
	4842.0	36.1	5.9	42.0	74.0	-32.0	Peak	Vertical
*	7086.0	36.4	11.9	48.3	79.7	-31.4	Peak	Vertical
*	10035.5	34.8	16.7	51.5	79.7	-28.2	Peak	Vertical

Note 1: "*" is not in restricted band, its limit is 20dBc of the fundamental emission level (99.7dBμV/m) or 15.209 which is higher.

Note 2: Measure Level (dBμV/m) = Reading Level (dBμV) + Factor (dB)

Factor (dB) = Cable Loss (dB) + Antenna Factor (dB/m) - Pre_Amplifier Gain (dB)

Product	Communication Module	Temperature	26°C
Test Engineer	Messiah Li	Relative Humidity	56%
Test Site	AC1	Test Date	2019/03/02
Test Mode:	3DH5	Test Channel:	00
Remark:	1. Average measurement was not performed if peak level lower than average limit. 2. Other frequency was 20dB below limit line within 1-18GHz, there is not show in the report.		

Mark	Frequency (MHz)	Reading Level (dBμV)	Factor (dB)	Measure Level (dBμV/m)	Limit (dBμV/m)	Margin (dB)	Detector	Polarization
	3745.5	37.8	2.4	40.2	74.0	-33.8	Peak	Horizontal
	4833.5	36.8	5.9	42.7	74.0	-31.3	Peak	Horizontal
*	6635.5	36.2	10.1	46.3	80.6	-34.3	Peak	Horizontal
*	10078.0	34.1	17.0	51.1	80.6	-29.5	Peak	Horizontal
	4264.0	37.9	4.2	42.1	74.0	-31.9	Peak	Vertical
	5029.0	35.8	6.4	42.2	74.0	-31.8	Peak	Vertical
*	6567.5	36.0	10.2	46.2	80.6	-34.4	Peak	Vertical
*	10358.5	34.3	17.4	51.7	80.6	-28.9	Peak	Vertical

Note 1: "*" is not in restricted band, its limit is 20dBc of the fundamental emission level (100.6dBμV/m) or 15.209 which is higher.

Note 2: Measure Level (dBμV/m) = Reading Level (dBμV) + Factor (dB)

Factor (dB) = Cable Loss (dB) + Antenna Factor (dB/m) - Pre_Amplifier Gain (dB)

Product	Communication Module	Temperature	26°C
Test Engineer	Messiah Li	Relative Humidity	56%
Test Site	AC1	Test Date	2019/03/02
Test Mode:	3DH5	Test Channel:	39
Remark:	1. Average measurement was not performed if peak level lower than average limit. 2. Other frequency was 20dB below limit line within 1-18GHz, there is not show in the report.		

Mark	Frequency (MHz)	Reading Level (dBμV)	Factor (dB)	Measure Level (dBμV/m)	Limit (dBμV/m)	Margin (dB)	Detector	Polarization
	3983.5	38.1	3.2	41.3	74.0	-32.7	Peak	Horizontal
	4799.5	36.4	5.8	42.2	74.0	-31.8	Peak	Horizontal
*	6329.5	36.7	9.0	45.7	80.3	-34.6	Peak	Horizontal
*	10307.5	33.9	17.3	51.2	80.3	-29.1	Peak	Horizontal
	4034.5	37.9	3.4	41.3	74.0	-32.7	Peak	Vertical
	5080.0	36.6	6.5	43.1	74.0	-30.9	Peak	Vertical
*	6304.0	35.9	8.8	44.7	80.3	-35.6	Peak	Vertical
*	10095.0	33.3	16.9	50.2	80.3	-30.1	Peak	Vertical

Note 1: "*" is not in restricted band, its limit is 20dBc of the fundamental emission level (100.3dBμV/m) or 15.209 which is higher.

Note 2: Measure Level (dBμV/m) = Reading Level (dBμV) + Factor (dB)

Factor (dB) = Cable Loss (dB) + Antenna Factor (dB/m) - Pre_Amplifier Gain (dB)

Product	Communication Module	Temperature	26°C
Test Engineer	Messiah Li	Relative Humidity	56%
Test Site	AC1	Test Date	2019/03/02
Test Mode:	3DH5	Test Channel:	78
Remark:	1. Average measurement was not performed if peak level lower than average limit. 2. Other frequency was 20dB below limit line within 1-18GHz, there is not show in the report.		

Mark	Frequency (MHz)	Reading Level (dBμV)	Factor (dB)	Measure Level (dBμV/m)	Limit (dBμV/m)	Margin (dB)	Detector	Polarization
	4094.0	37.0	3.6	40.6	74.0	-33.4	Peak	Horizontal
	5037.5	35.9	6.5	42.4	74.0	-31.6	Peak	Horizontal
*	6499.5	36.0	9.9	45.9	79.7	-33.8	Peak	Horizontal
*	10146.0	33.8	17.0	50.8	79.7	-28.9	Peak	Horizontal
	4034.5	37.3	3.4	40.7	74.0	-33.3	Peak	Vertical
	4884.5	36.1	6.0	42.1	74.0	-31.9	Peak	Vertical
*	6550.5	36.2	10.2	46.4	79.7	-33.3	Peak	Vertical
*	10205.5	34.7	17.1	51.8	79.7	-27.9	Peak	Vertical

Note 1: "*" is not in restricted band, its limit is 20dBc of the fundamental emission level (99.7dBμV/m) or 15.209 which is higher.

Note 2: Measure Level (dBμV/m) = Reading Level (dBμV) + Factor (dB)

Factor (dB) = Cable Loss (dB) + Antenna Factor (dB/m) - Pre_Amplifier Gain (dB)

The Worst Case of Radiated Emission below 1GHz:

Site: AC1	Time: 2019/03/06 - 01:14
Limit: FCC_Part15.209_RSE(3m)	Engineer: Messiah Li
Probe: VULB 9168 _20-2000MHz	Polarity: Horizontal
EUT: Communication Module	Power: DC 3.3V
Test Mode: Worst case	

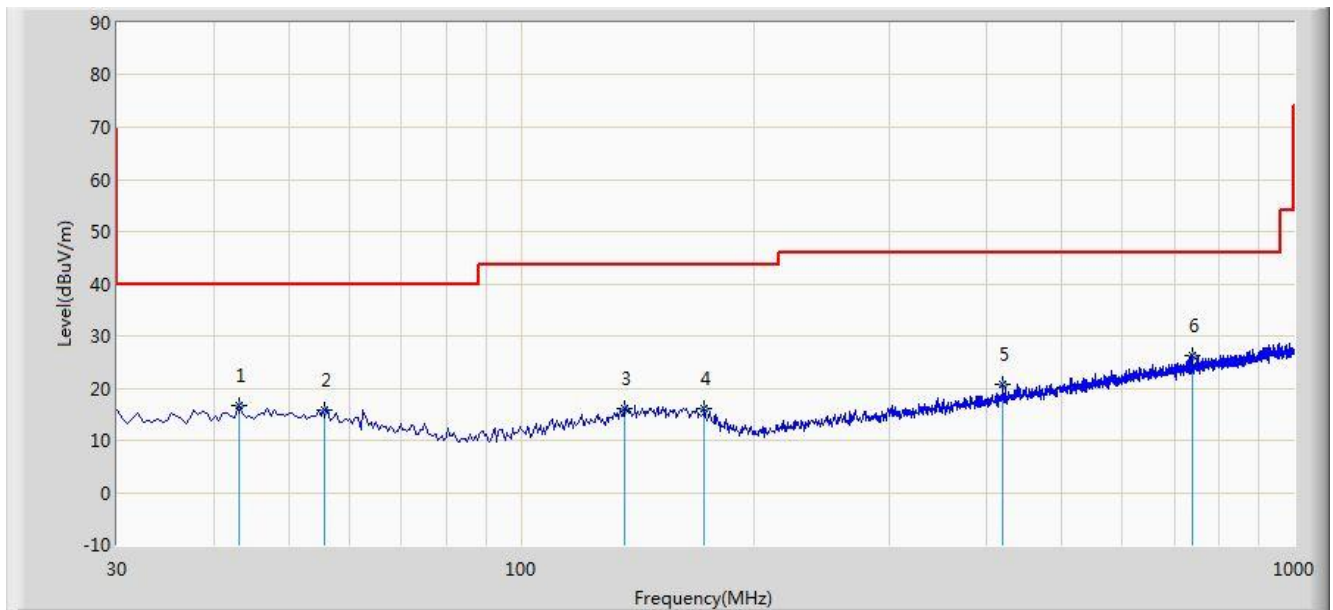

No	Flag	Mark	Frequency (MHz)	Measure Level (dBuV/m)	Reading Level (dBuV)	Over Limit (dB)	Limit (dBuV/m)	Factor (dB)	Type
1			43.095	16.585	2.169	-23.415	40.000	14.416	QP
2			55.705	15.740	1.965	-24.260	40.000	13.775	QP
3			136.215	16.068	1.762	-27.432	43.500	14.306	QP
4			172.590	15.957	1.958	-27.543	43.500	13.999	QP
5			419.940	20.610	3.467	-25.390	46.000	17.143	QP
6		*	738.100	26.190	3.556	-19.810	46.000	22.634	QP

Note 1: Measure Level (dB μ V/m) = Reading Level (dB μ V) + Factor (dB)

Factor (dB) = Cable Loss (dB) + Antenna Factor (dB/m)

Note 2: The test trace is same as the ambient noise and the amplitude of the emissions are attenuated more than 20dB below the permissible (the test frequency range: 9kHz ~ 30MHz, 18GHz ~ 25GHz), therefore no data appear in the report.

Site: AC1	Time: 2019/03/06 - 01:15
Limit: FCC_Part15.209_RSE(3m)	Engineer: Messiah Li
Probe: VULB 9168 _20-2000MHz	Polarity: Vertical
EUT: Communication Module	Power: DC 3.3V
Test Mode: Worst case	

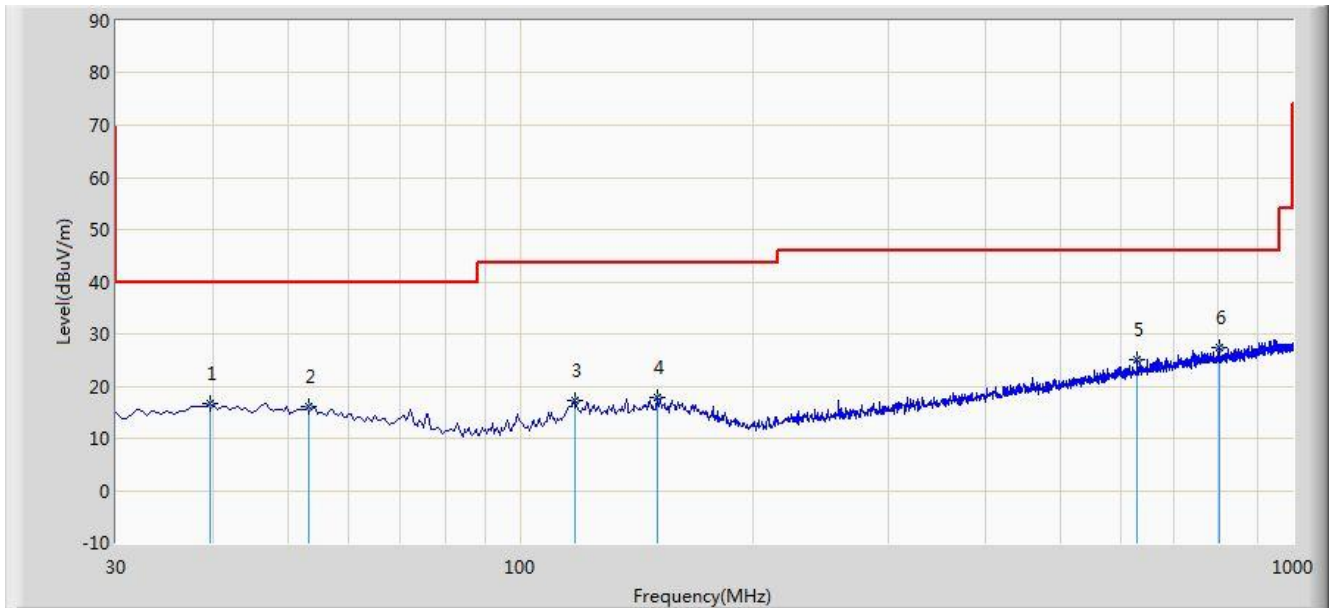

No	Flag	Mark	Frequency (MHz)	Measure Level (dBuV/m)	Reading Level (dBuV)	Over Limit (dB)	Limit (dBuV/m)	Factor (dB)	Type
1			39.700	16.696	2.083	-23.304	40.000	14.613	QP
2			53.280	16.053	2.098	-23.947	40.000	13.955	QP
3			117.785	17.142	4.156	-26.358	43.500	12.986	QP
4			150.280	17.687	2.422	-25.813	43.500	15.265	QP
5			627.520	24.961	3.821	-21.039	46.000	21.140	QP
6		*	803.090	27.369	4.027	-18.631	46.000	23.342	QP

Note 1: Measure Level (dB μ V/m) = Reading Level (dB μ V) + Factor (dB)

Factor (dB) = Cable Loss (dB) + Antenna Factor (dB/m)

Note 2: The test trace is same as the ambient noise and the amplitude of the emissions are attenuated more than 20dB below the permissible (the test frequency range: 9kHz ~ 30MHz, 18GHz ~ 25GHz), therefore no data appear in the report.

6.10. Radiated Restricted Band Edge Measurement

6.10.1. Test Limit

For 15.205 requirement:

Radiated emissions which fall in the restricted bands, as defined in Section 15.205(a) of FCC part 15, must also comply with the radiated emission limits specified in Section 15.209(a).

Frequency (MHz)	Frequency (MHz)	Frequency (MHz)	Frequency (GHz)
0.090 - 0.110	16.42 - 16.423	399.9 - 410	4.5 - 5.15
¹ 0.495 - 0.505	16.69475 - 16.69525	608 - 614	5.35 - 5.46
2.1735 - 2.1905	16.80425 - 16.80475	960 - 1240	7.25 - 7.75
4.125 - 4.128	25.5 - 25.67	1300 - 1427	8.025 - 8.5
4.17725 - 4.17775	37.5 - 38.25	1435 - 1626.5	9.0 - 9.2
4.20725 - 4.20775	73 - 74.6	1645.5 - 1646.5	9.3 - 9.5
6.215 - 6.218	74.8 - 75.2	1660 - 1710	10.6 - 12.7
6.26775 - 6.26825	108 - 121.94	1718.8 - 1722.2	13.25 - 13.4
6.31175 - 6.31225	123 - 138	2200 - 2300	14.47 - 14.5
8.291 - 8.294	149.9 - 150.05	2310 - 2390	15.35 - 16.2
8.362 - 8.366	156.52475 - 156.525	2483.5 - 2500	17.7 - 21.4
8.37625 - 8.38675	156.7 - 156.9	2690 - 2900	22.01 - 23.12
8.41425 - 8.41475	162.0125 - 167.17	3260 - 3267	23.6 - 24.0
12.29 - 12.293	167.72 - 173.2	3332 - 3339	31.2 - 31.8
12.51975 - 12.52025	240 - 285	3345.8 - 3358	36.43 - 36.5
12.57675 - 12.57725	322 - 335.4	3600 - 4400	(²)
13.36 - 13.41	--	--	--

All out of band emissions appearing in a restricted band as specified in Section 15.205 of the Title 47CFR must not exceed the limits shown in Table per Section 15.209.

FCC Part 15 Subpart C Paragraph 15.209		
Frequency [MHz]	Field Strength [uV/m]	Measured Distance [Meters]
0.009 - 0.490	2400/F (kHz)	300
0.490 - 1.705	24000/F (kHz)	30
1.705 - 30	30	30
30 - 88	100	3
88 - 216	150	3
216 - 960	200	3
Above 960	500	3

For RSS-Gen Section 8.10 requirement:

Radiated emissions which fall in the restricted bands, as defined in Section 8.10 of RSS-Gen, must also comply with the radiated emission limits specified in Section 8.9.

Frequency (MHz)	Frequency (MHz)	Frequency (GHz)
0.090 - 0.110	149.9 -150.5	9.0 - 9.2
0.495 -0.505	156.52475 - 156.525225	9.3 - 9.5
2.1735 - 2.1905	156.7 - 156.9	10.6 - 12.7
3.020 - 3.026	162.0125 - 167.17	13.25 - 13.4
4.125 - 4.128	167.72 - 173.2	14.47 - 14.5
4.17725 - 4.17775	240 - 285	15.35 - 16.2
4.20725 - 4.20775	322 - 335.4	17.7 - 21.4
5.677 - 5.683	399.9 - 410	22.01 - 23.12
6.215 - 6.218	608 - 614	23.6 - 24.0
6.26775 - 6.26825	960 - 1427	31.2 - 31.8
6.31175 - 6.31225	1435 - 1626.5	36.43 - 36.5
8.291 - 8.294	1645.5 - 1646.5	Above 38.6
8.362 - 8.366	1660 - 1710	--
8.37625 - 8.38675	1718.8 -1722.2	
8.41425 - 8.41475	2200 - 2300	
12.29 - 12.293	2310 -2390	
12.51975 - 12.52025	2483.5 - 2500	
12.57675 - 12.57725	2655 - 2900	
13.36 -13.41	3260 - 3267	
16.42 - 16.423	3332 -3339	
16.69475 - 16.69525	334.5 - 3358	
16.80425 - 16.80475	3500 - 4400	
25.5 - 25.67	4500 - 5150	
37.5 - 38.25	5350 - 5460	
73 - 74.6	7250 - 7750	
74.8 - 75.2	8025 - 8500	
108 - 138	--	

All out of band emissions appearing in a restricted band as specified in Section 8.10 of the RSS-Gen must not exceed the limits shown in Table per Section 8.9.

RSS-Gen Section 8.9			
Frequency [MHz]	Magnetic field strength (H-Field) [uA/m]	Field Strength [uV/m]	Measured Distance [Meters]
0.009 - 0.490	6.37/F(F in kHz)	--	300
0.490 - 1.705	63.7/F(F in kHz)	--	30
1.705 - 30	0.08	--	30
30 - 88	--	100	3
88 - 216	--	150	3
216 - 960	--	200	3
Above 960	--	500	3

6.10.2. Test Procedure Used

ANSI C63.10 Section 6.3 (General Requirements)

ANSI C63.10 Section 6.6 (Standard test method above 1GHz)

6.10.3. Test Setting

Peak Field Strength Measurements

1. Analyzer center frequency was set to the frequency of the radiated spurious emission of interest
2. RBW = 1MHz
3. VBW = 3MHz
4. Detector = peak
5. Sweep time = auto couple
6. Trace mode = max hold
7. Trace was allowed to stabilize

Average Measurements above 1GHz (Method VB)

1. Analyzer center frequency was set to the frequency of the radiated spurious emission of interest
2. RBW = 1MHz
3. VBW; If the EUT is configured to transmit with duty cycle $\geq 98\%$, set VBW = 10 Hz.

If the EUT duty cycle is $< 98\%$, set $VBW \geq 1/T$. T is the minimum transmission duration.

4. Detector = Peak
5. Sweep time = auto
6. Trace mode = max hold
7. Trace was allowed to stabilize

6.10.4. Test Setup

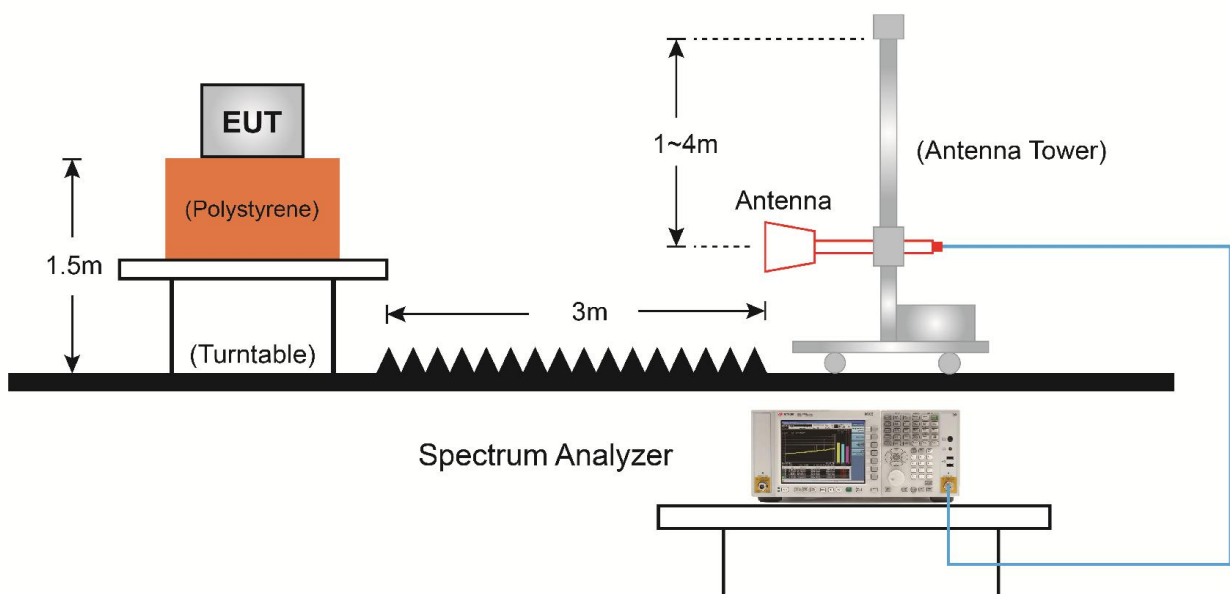

6.10.5. Test Result

Site: AC1	Time: 2019/03/02 - 03:00
Limit: FCC_Part15_Band Edge(3m)	Engineer: Messiah Li
Probe: BBHA9120D_1-18GHz	Polarity: Horizontal
EUT: Communication Module	Power: DC 3.3V
Note: Transmit by DH5 at channel 2402MHz	

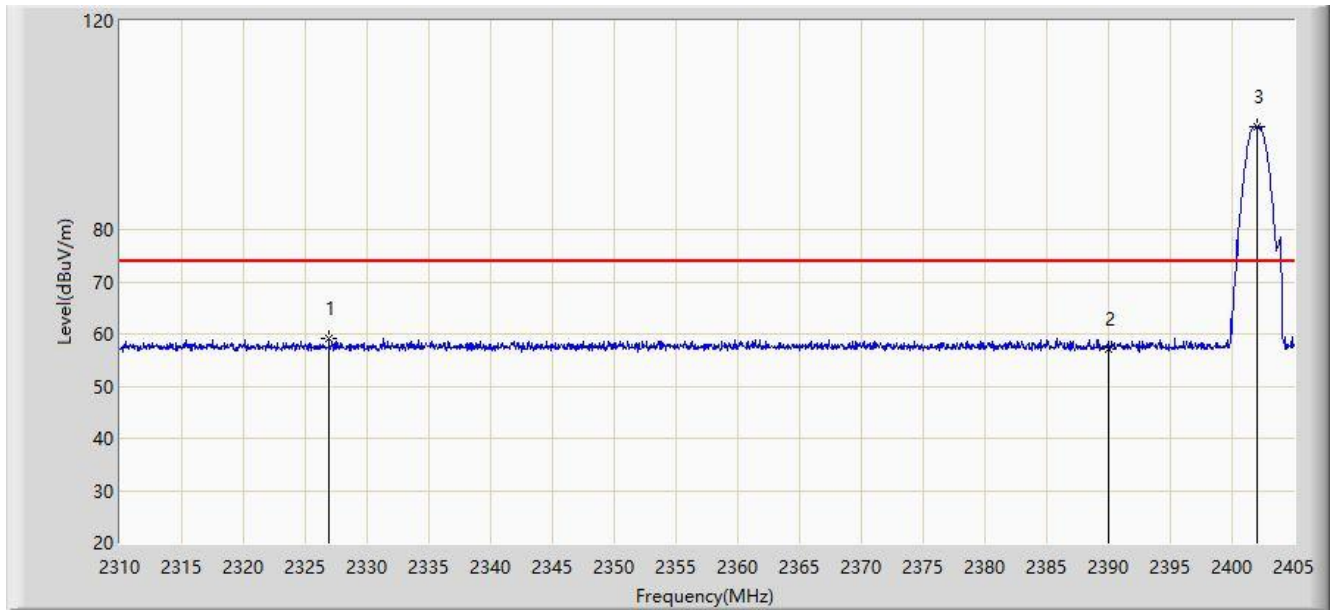

No	Flag	Mark	Frequency (MHz)	Measure Level (dBuV/m)	Reading Level (dBuV)	Over Limit (dB)	Limit (dBuV/m)	Factor (dB)	Type
1			2326.910	59.074	26.585	-14.926	74.000	32.490	PK
2			2390.000	57.111	24.784	-16.889	74.000	32.327	PK
3		*	2402.008	99.803	67.499	N/A	N/A	32.305	PK

Note: Measure Level (dB μ V/m) = Reading Level (dB μ V) + Factor (dB)

Factor (dB) = Cable Loss (dB) + Antenna Factor (dB/m)

Site: AC1	Time: 2019/03/02 - 03:04
Limit: FCC_Part15_Band Edge(3m)	Engineer: Messiah Li
Probe: BBHA9120D_1-18GHz	Polarity: Horizontal
EUT: Communication Module	Power: DC 3.3V
Note: Transmit by DH5 at channel 2402MHz	

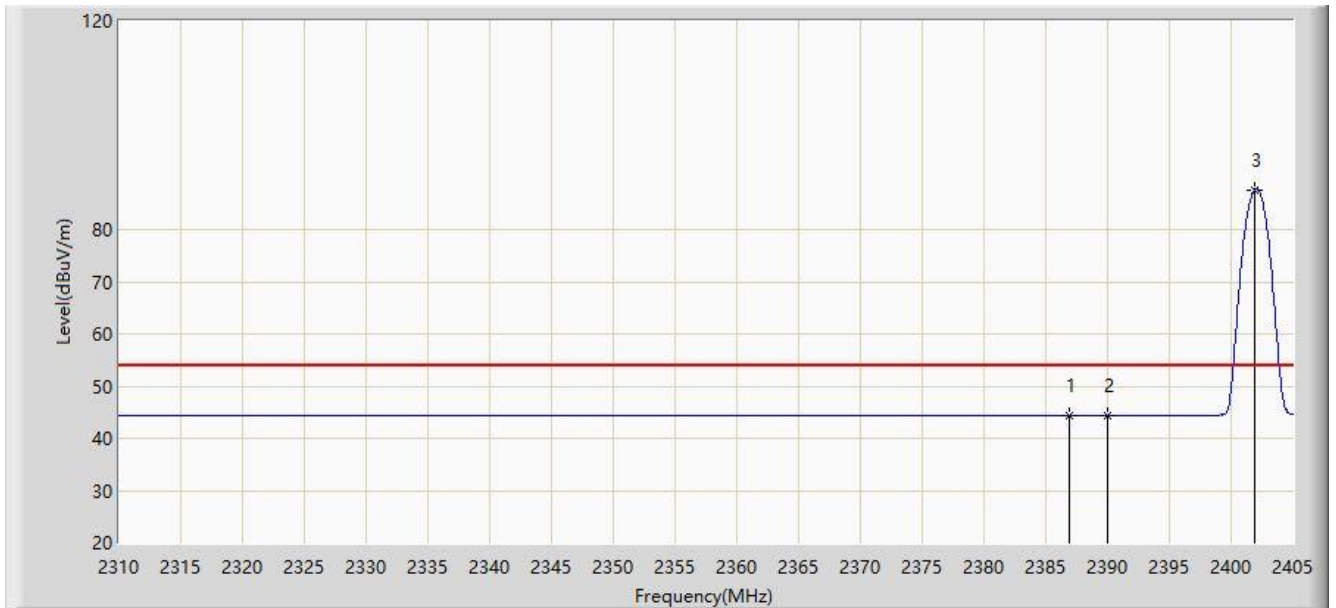

No	Flag	Mark	Frequency (MHz)	Measure Level (dBuV/m)	Reading Level (dBuV)	Over Limit (dB)	Limit (dBuV/m)	Factor (dB)	Type
1			2386.950	44.454	12.123	-9.546	54.000	32.331	AV
2			2390.000	44.403	12.076	-9.597	54.000	32.327	AV
3		*	2401.913	87.664	55.359	N/A	N/A	32.305	AV

Note: Measure Level (dB μ V/m) = Reading Level (dB μ V) + Factor (dB)

Factor (dB) = Cable Loss (dB) + Antenna Factor (dB/m)

Site: AC1	Time: 2019/03/02 - 03:05
Limit: FCC_Part15_Band Edge(3m)	Engineer: Messiah Li
Probe: BBHA9120D_1-18GHz	Polarity: Vertical
EUT: Communication Module	Power: DC 3.3V
Note: Transmit by DH5 at channel 2402MHz	

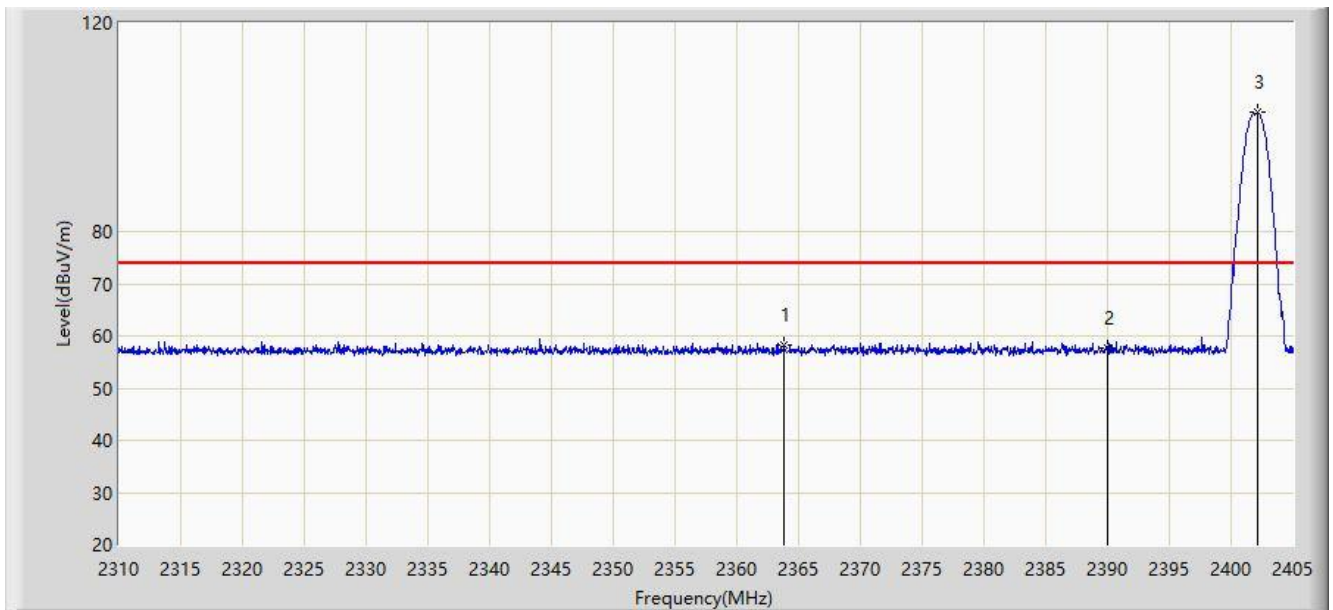

No	Flag	Mark	Frequency (MHz)	Measure Level (dBuV/m)	Reading Level (dBuV)	Over Limit (dB)	Limit (dBuV/m)	Factor (dB)	Type
1			2363.817	58.377	26.007	-15.623	74.000	32.370	PK
2			2390.000	57.777	25.450	-16.223	74.000	32.327	PK
3		*	2402.103	102.793	70.489	N/A	N/A	32.304	PK

Note: Measure Level (dB μ V/m) = Reading Level (dB μ V) + Factor (dB)

Factor (dB) = Cable Loss (dB) + Antenna Factor (dB/m)

Site: AC1	Time: 2019/03/02 - 03:06
Limit: FCC_Part15_Band Edge(3m)	Engineer: Messiah Li
Probe: BBHA9120D_1-18GHz	Polarity: Vertical
EUT: Communication Module	Power: DC 3.3V
Note: Transmit by DH5 at channel 2402MHz	

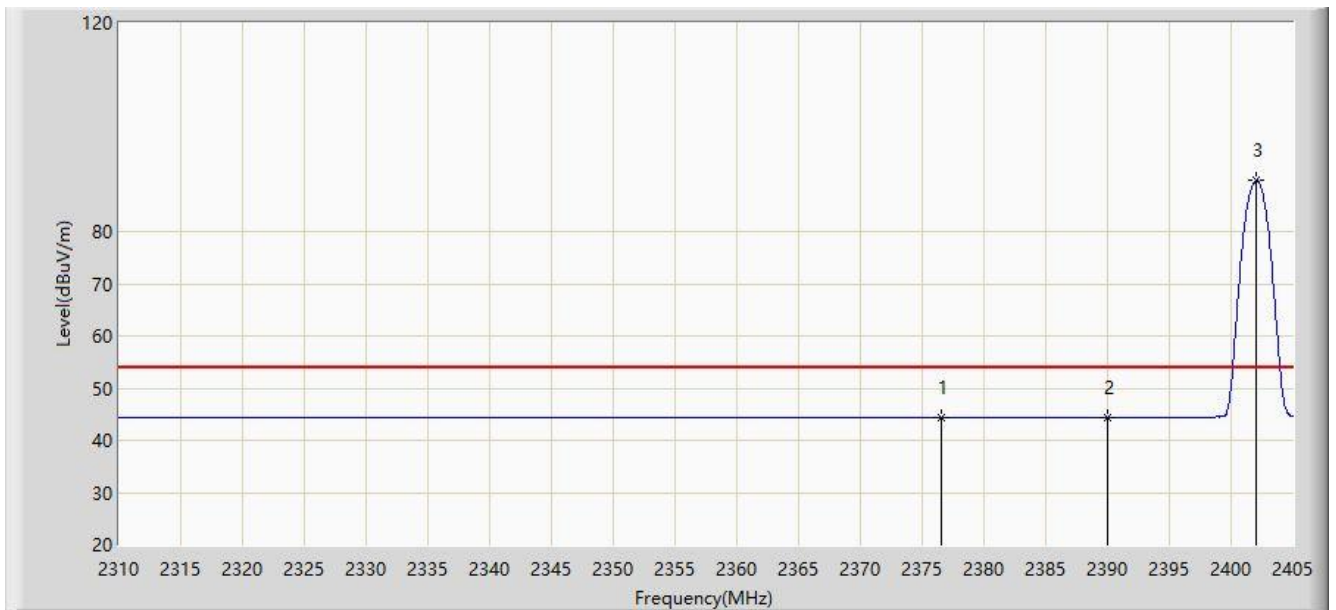

No	Flag	Mark	Frequency (MHz)	Measure Level (dBuV/m)	Reading Level (dBuV)	Over Limit (dB)	Limit (dBuV/m)	Factor (dB)	Type
1			2376.595	44.410	12.065	-9.590	54.000	32.346	AV
2			2390.000	44.382	12.055	-9.618	54.000	32.327	AV
3		*	2402.008	89.728	57.424	N/A	N/A	32.305	AV

Note: Measure Level (dB μ V/m) = Reading Level (dB μ V) + Factor (dB)

Factor (dB) = Cable Loss (dB) + Antenna Factor (dB/m)

Site: AC1	Time: 2019/03/02 - 03:08
Limit: FCC_Part15_Band Edge(3m)	Engineer: Messiah Li
Probe: BBHA9120D_1-18GHz	Polarity: Horizontal
EUT: Communication Module	Power: DC 3.3V
Note: Transmit by DH5 at channel 2480MHz	

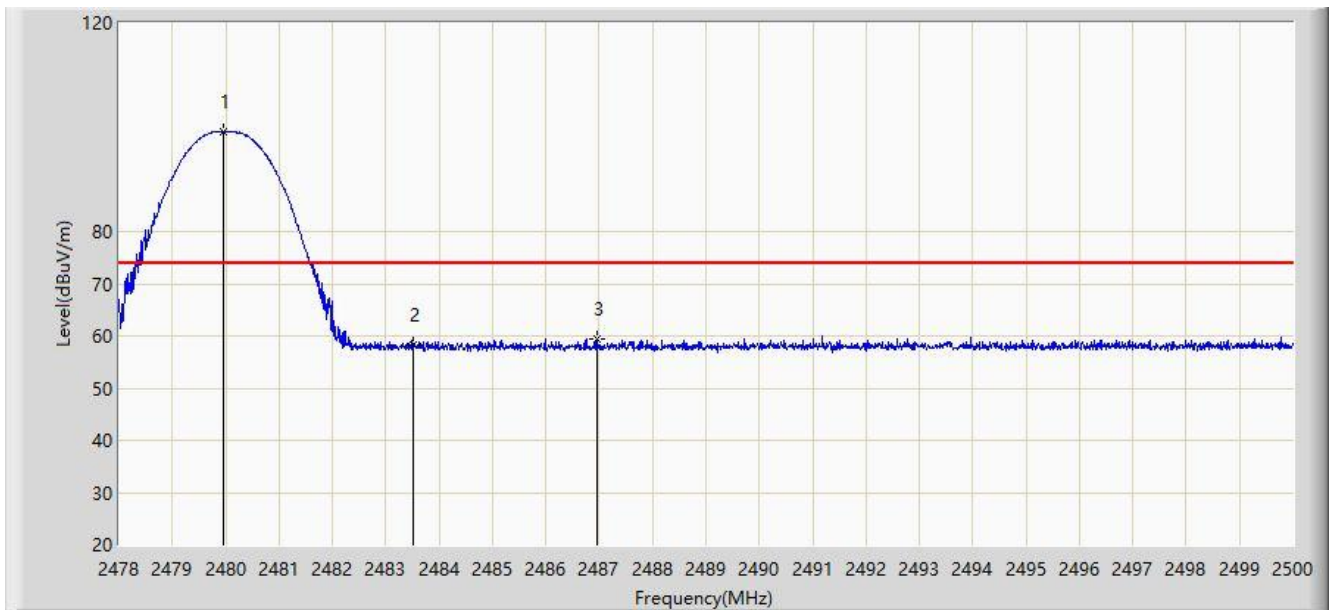

No	Flag	Mark	Frequency (MHz)	Measure Level (dBuV/m)	Reading Level (dBuV)	Over Limit (dB)	Limit (dBuV/m)	Factor (dB)	Type
1		*	2479.969	99.123	66.798	N/A	N/A	32.325	PK
2			2483.500	58.361	26.022	-15.639	74.000	32.340	PK
3			2486.965	59.361	27.008	-14.639	74.000	32.353	PK

Note: Measure Level (dB μ V/m) = Reading Level (dB μ V) + Factor (dB)

Factor (dB) = Cable Loss (dB) + Antenna Factor (dB/m)

Site: AC1	Time: 2019/03/02 - 03:15
Limit: FCC_Part15_Band Edge(3m)	Engineer: Messiah Li
Probe: BBHA9120D_1-18GHz	Polarity: Horizontal
EUT: Communication Module	Power: DC 3.3V
Note: Transmit by DH5 at channel 2480MHz	

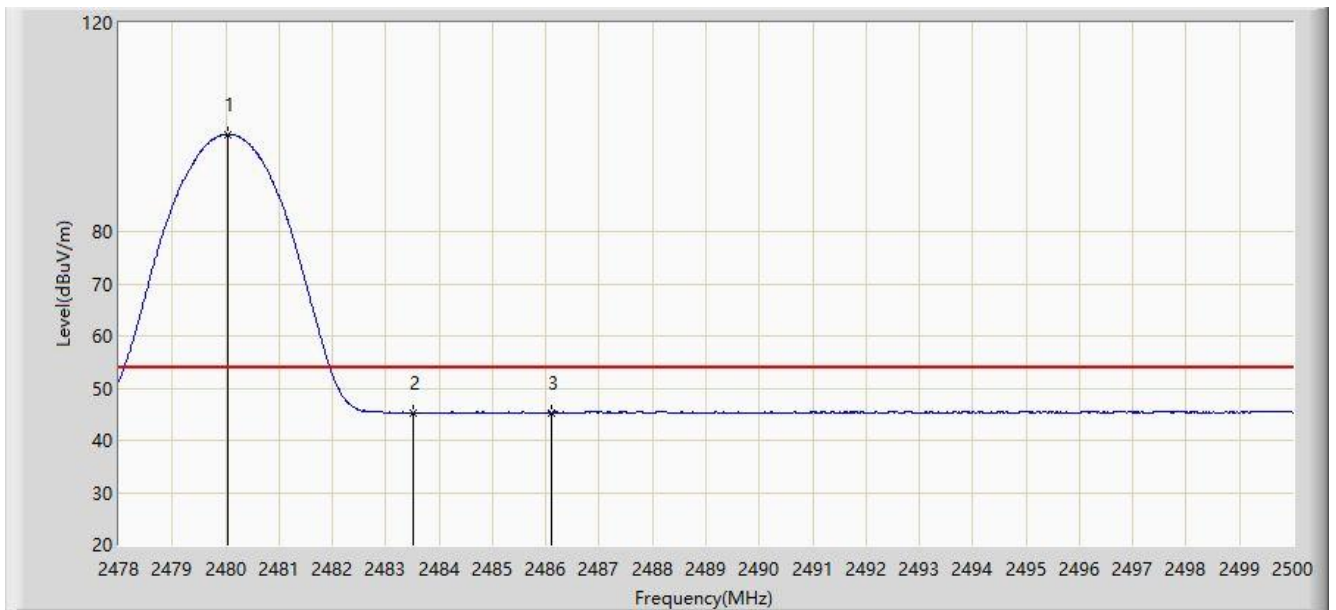

No	Flag	Mark	Frequency (MHz)	Measure Level (dBuV/m)	Reading Level (dBuV)	Over Limit (dB)	Limit (dBuV/m)	Factor (dB)	Type
1		*	2480.046	98.642	66.316	N/A	N/A	32.325	AV
2			2483.500	45.218	12.879	-8.782	54.000	32.340	AV
3			2486.096	45.316	12.967	-8.684	54.000	32.349	AV

Note: Measure Level (dB μ V/m) = Reading Level (dB μ V) + Factor (dB)

Factor (dB) = Cable Loss (dB) + Antenna Factor (dB/m)

Site: AC1	Time: 2019/03/02 - 03:17
Limit: FCC_Part15_Band Edge(3m)	Engineer: Messiah Li
Probe: BBHA9120D_1-18GHz	Polarity: Vertical
EUT: Communication Module	Power: DC 3.3V
Note: Transmit by DH5 at channel 2480MHz	

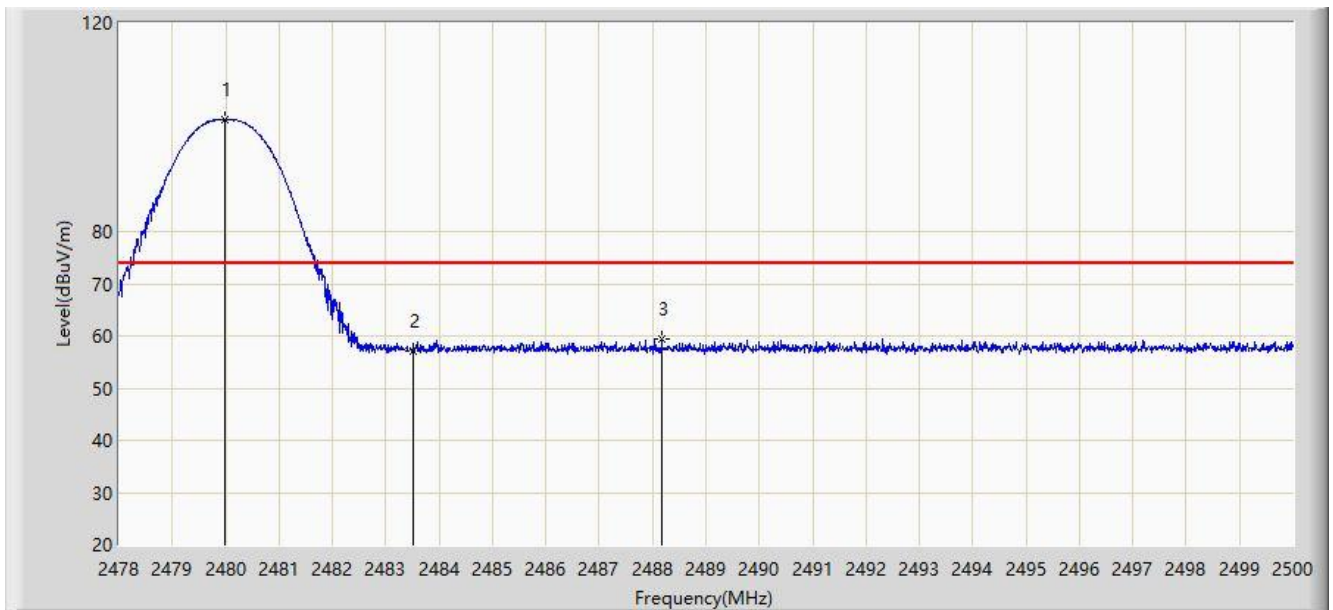

No	Flag	Mark	Frequency (MHz)	Measure Level (dBuV/m)	Reading Level (dBuV)	Over Limit (dB)	Limit (dBuV/m)	Factor (dB)	Type
1		*	2479.980	101.551	69.226	N/A	N/A	32.325	PK
2			2483.500	57.152	24.813	-16.848	74.000	32.340	PK
3			2488.175	59.355	26.998	-14.645	74.000	32.357	PK

Note: Measure Level (dB μ V/m) = Reading Level (dB μ V) + Factor (dB)

Factor (dB) = Cable Loss (dB) + Antenna Factor (dB/m)

Site: AC1	Time: 2019/03/02 - 03:18
Limit: FCC_Part15_Band Edge(3m)	Engineer: Messiah Li
Probe: BBHA9120D_1-18GHz	Polarity: Vertical
EUT: Communication Module	Power: DC 3.3V
Note: Transmit by DH5 at channel 2480MHz	

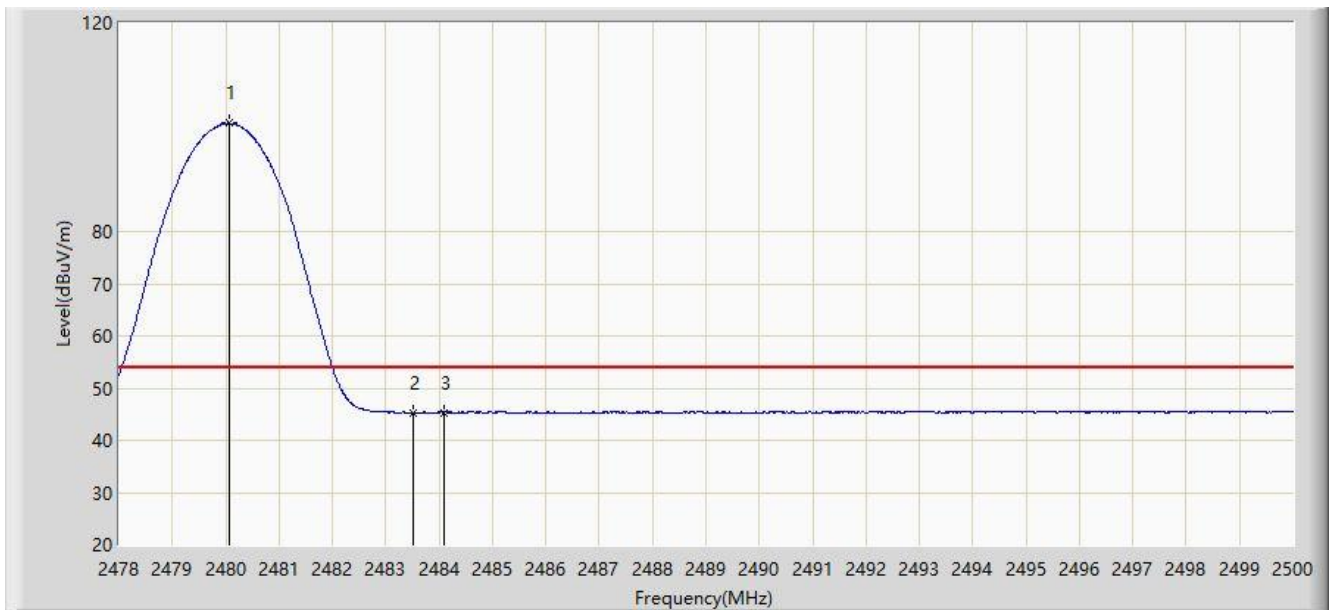

No	Flag	Mark	Frequency (MHz)	Measure Level (dBuV/m)	Reading Level (dBuV)	Over Limit (dB)	Limit (dBuV/m)	Factor (dB)	Type
1		*	2480.079	100.731	68.405	N/A	N/A	32.325	AV
2			2483.500	45.331	12.992	-8.669	54.000	32.340	AV
3			2484.083	45.346	13.005	-8.654	54.000	32.342	AV

Note: Measure Level (dB μ V/m) = Reading Level (dB μ V) + Factor (dB)

Factor (dB) = Cable Loss (dB) + Antenna Factor (dB/m)

Site: AC1	Time: 2019/03/02 - 03:19
Limit: FCC_Part15_Band Edge(3m)	Engineer: Messiah Li
Probe: BBHA9120D_1-18GHz	Polarity: Horizontal
EUT: Communication Module	Power: DC 3.3V
Note: Transmit by 2DH5 at channel 2402MHz	

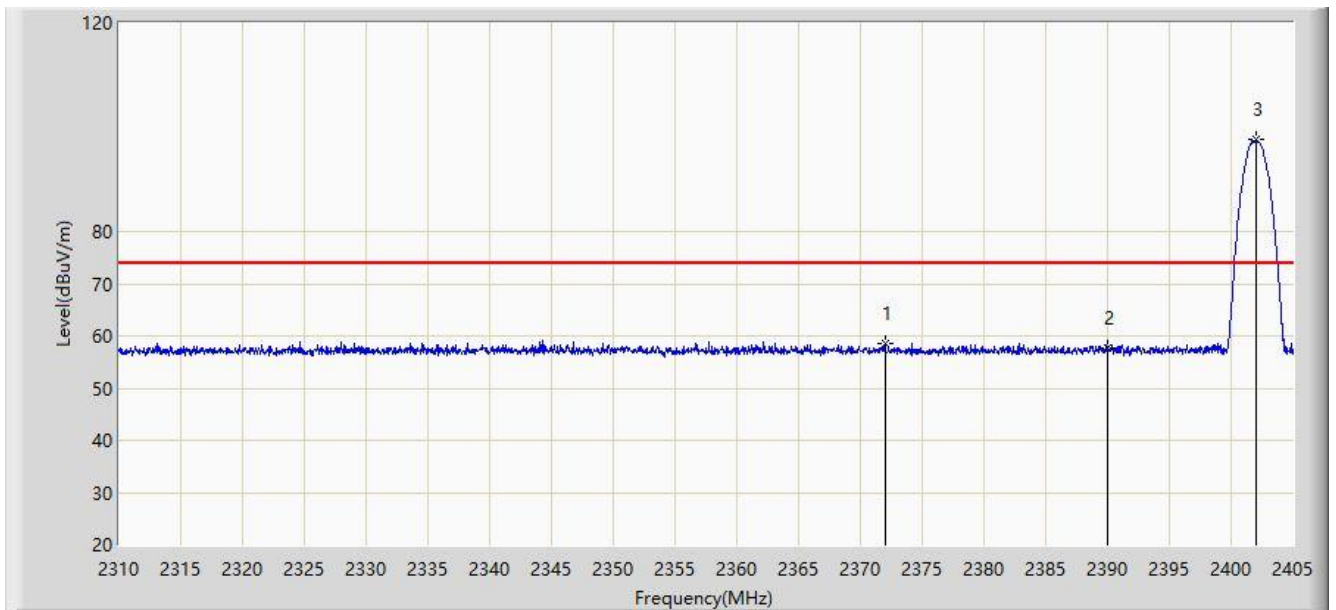

No	Flag	Mark	Frequency (MHz)	Measure Level (dBuV/m)	Reading Level (dBuV)	Over Limit (dB)	Limit (dBuV/m)	Factor (dB)	Type
1			2371.988	58.494	26.140	-15.506	74.000	32.354	PK
2			2390.000	57.789	25.462	-16.211	74.000	32.327	PK
3		*	2402.008	97.538	65.234	N/A	N/A	32.305	PK

Note: Measure Level (dB μ V/m) = Reading Level (dB μ V) + Factor (dB)

Factor (dB) = Cable Loss (dB) + Antenna Factor (dB/m)

Site: AC1	Time: 2019/03/02 - 03:22
Limit: FCC_Part15_Band Edge(3m)	Engineer: Messiah Li
Probe: BBHA9120D_1-18GHz	Polarity: Horizontal
EUT: Communication Module	Power: DC 3.3V
Note: Transmit by 2DH5 at channel 2402MHz	

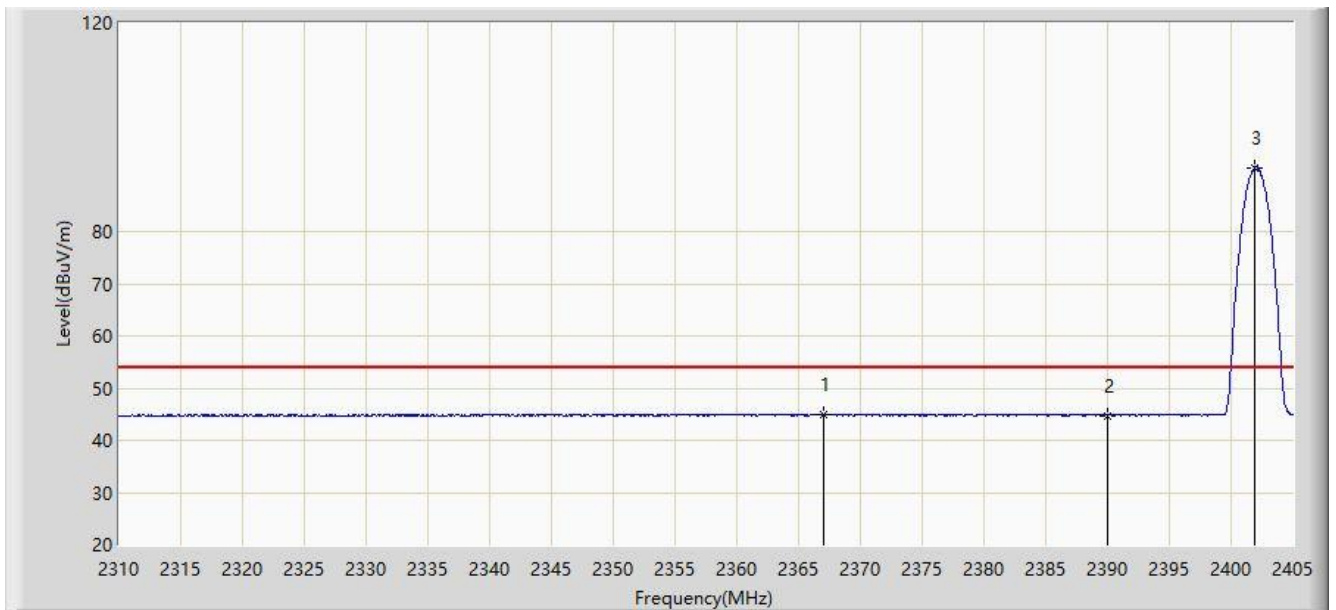

No	Flag	Mark	Frequency (MHz)	Measure Level (dBuV/m)	Reading Level (dBuV)	Over Limit (dB)	Limit (dBuV/m)	Factor (dB)	Type
1			2367.048	45.013	12.650	-8.987	54.000	32.363	AV
2			2390.000	44.763	12.436	-9.237	54.000	32.327	AV
3		*	2401.865	92.270	59.965	N/A	N/A	32.305	AV

Note: Measure Level (dB μ V/m) = Reading Level (dB μ V) + Factor (dB)

Factor (dB) = Cable Loss (dB) + Antenna Factor (dB/m)

Site: AC1	Time: 2019/03/02 - 03:24
Limit: FCC_Part15_Band Edge(3m)	Engineer: Messiah Li
Probe: BBHA9120D_1-18GHz	Polarity: Vertical
EUT: Communication Module	Power: DC 3.3V
Note: Transmit by 2DH5 at channel 2402MHz	

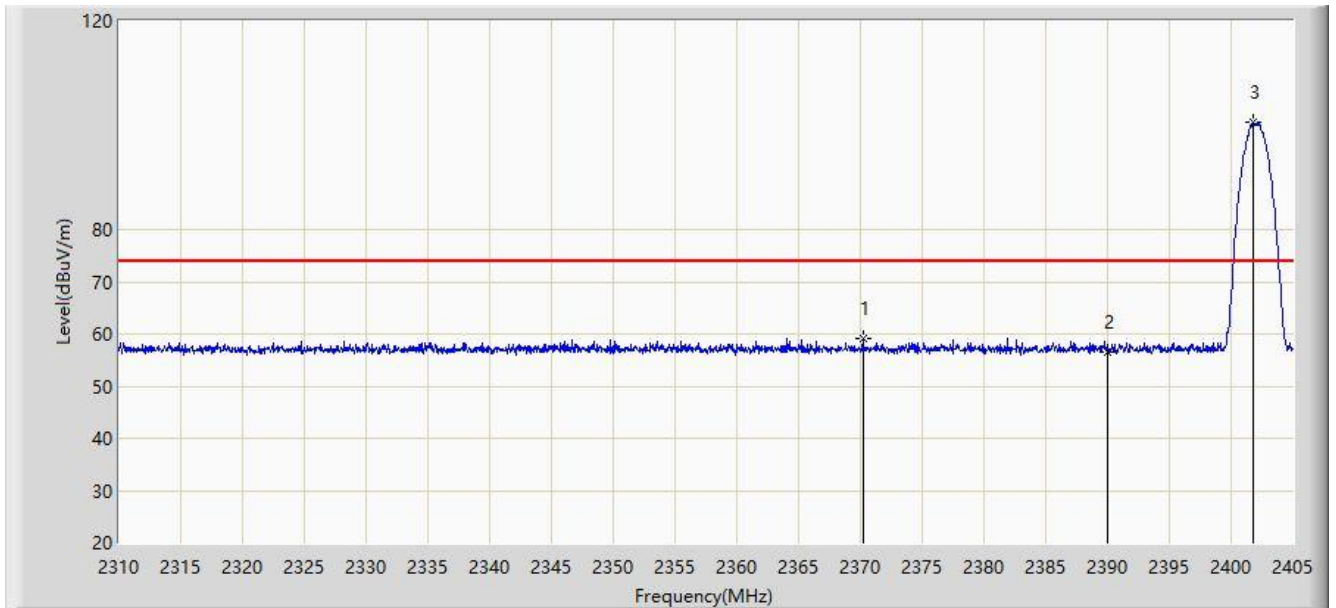

No	Flag	Mark	Frequency (MHz)	Measure Level (dBuV/m)	Reading Level (dBuV)	Over Limit (dB)	Limit (dBuV/m)	Factor (dB)	Type
1			2370.183	59.084	26.727	-14.916	74.000	32.357	PK
2			2390.000	56.552	24.225	-17.448	74.000	32.327	PK
3		*	2401.770	100.597	68.292	N/A	N/A	32.305	PK

Note: Measure Level (dB μ V/m) = Reading Level (dB μ V) + Factor (dB)

Factor (dB) = Cable Loss (dB) + Antenna Factor (dB/m)

Site: AC1	Time: 2019/03/02 - 03:25
Limit: FCC_Part15_Band Edge(3m)	Engineer: Messiah Li
Probe: BBHA9120D_1-18GHz	Polarity: Vertical
EUT: Communication Module	Power: DC 3.3V
Note: Transmit by 2DH5 at channel 2402MHz	

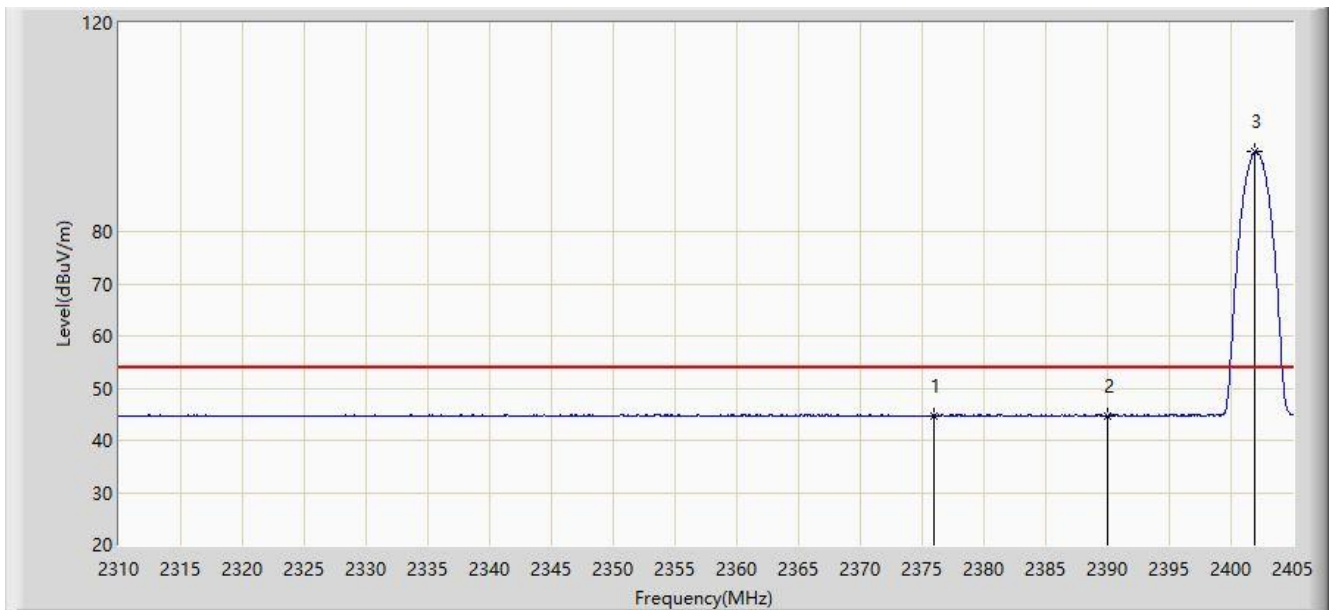

No	Flag	Mark	Frequency (MHz)	Measure Level (dBuV/m)	Reading Level (dBuV)	Over Limit (dB)	Limit (dBuV/m)	Factor (dB)	Type
1			2375.978	44.739	12.392	-9.261	54.000	32.346	AV
2			2390.000	44.671	12.344	-9.329	54.000	32.327	AV
3		*	2401.960	95.378	63.073	N/A	N/A	32.305	AV

Note: Measure Level (dB μ V/m) = Reading Level (dB μ V) + Factor (dB)

Factor (dB) = Cable Loss (dB) + Antenna Factor (dB/m)

Site: AC1	Time: 2019/03/02 - 03:26
Limit: FCC_Part15_Band Edge(3m)	Engineer: Messiah Li
Probe: BBHA9120D_1-18GHz	Polarity: Horizontal
EUT: Communication Module	Power: DC 3.3V
Note: Transmit by 2DH5 at channel 2480MHz	

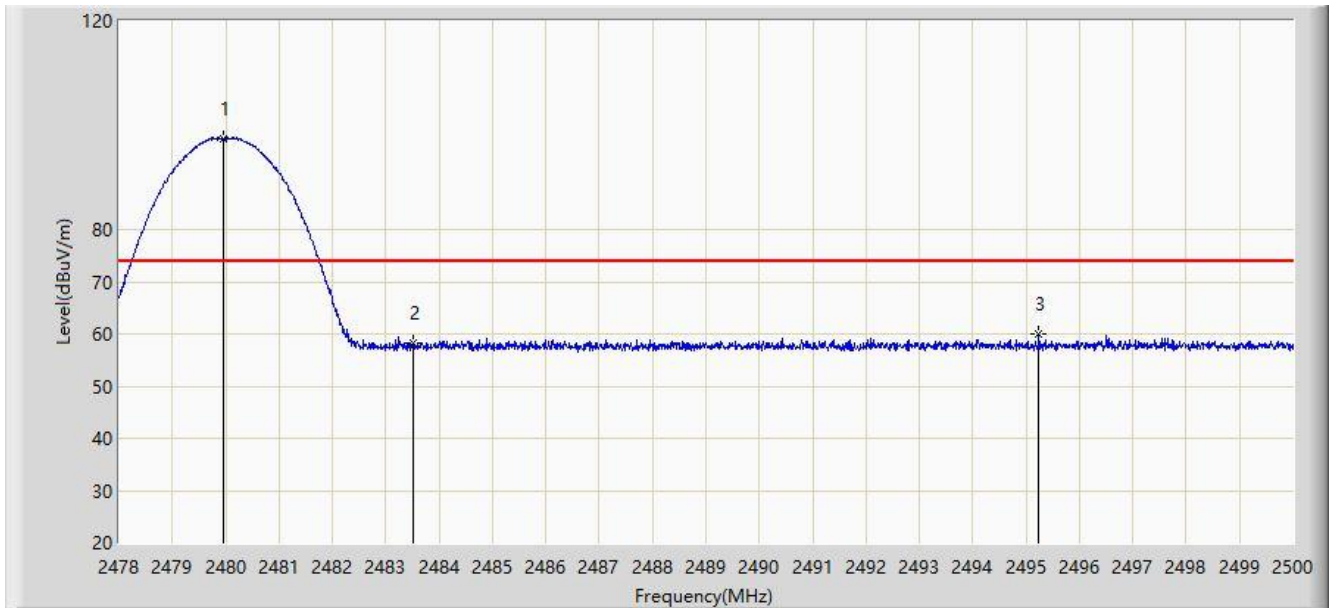

No	Flag	Mark	Frequency (MHz)	Measure Level (dBuV/m)	Reading Level (dBuV)	Over Limit (dB)	Limit (dBuV/m)	Factor (dB)	Type
1		*	2479.969	97.279	64.954	N/A	N/A	32.325	PK
2			2483.500	58.274	25.935	-15.726	74.000	32.340	PK
3			2495.237	60.025	27.640	-13.975	74.000	32.385	PK

Note: Measure Level (dB μ V/m) = Reading Level (dB μ V) + Factor (dB)

Factor (dB) = Cable Loss (dB) + Antenna Factor (dB/m)

Site: AC1	Time: 2019/03/02 - 03:28
Limit: FCC_Part15_Band Edge(3m)	Engineer: Messiah Li
Probe: BBHA9120D_1-18GHz	Polarity: Horizontal
EUT: Communication Module	Power: DC 3.3V
Note: Transmit by 2DH5 at channel 2480MHz	

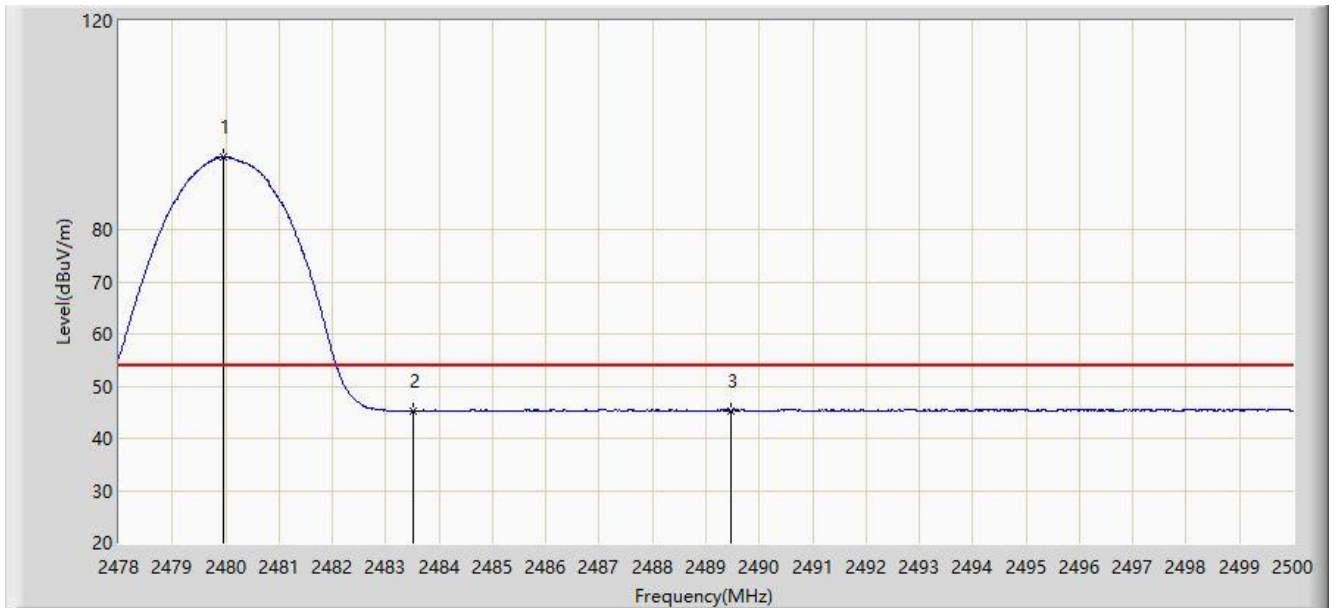

No	Flag	Mark	Frequency (MHz)	Measure Level (dBuV/m)	Reading Level (dBuV)	Over Limit (dB)	Limit (dBuV/m)	Factor (dB)	Type
1		*	2479.969	93.852	61.527	N/A	N/A	32.325	AV
2			2483.500	45.312	12.973	-8.688	54.000	32.340	AV
3			2489.462	45.315	12.952	-8.685	54.000	32.362	AV

Note: Measure Level (dB μ V/m) = Reading Level (dB μ V) + Factor (dB)

Factor (dB) = Cable Loss (dB) + Antenna Factor (dB/m)

Site: AC1	Time: 2019/03/02 - 03:28
Limit: FCC_Part15_Band Edge(3m)	Engineer: Messiah Li
Probe: BBHA9120D_1-18GHz	Polarity: Vertical
EUT: Communication Module	Power: DC 3.3V
Note: Transmit by 2DH5 at channel 2480MHz	

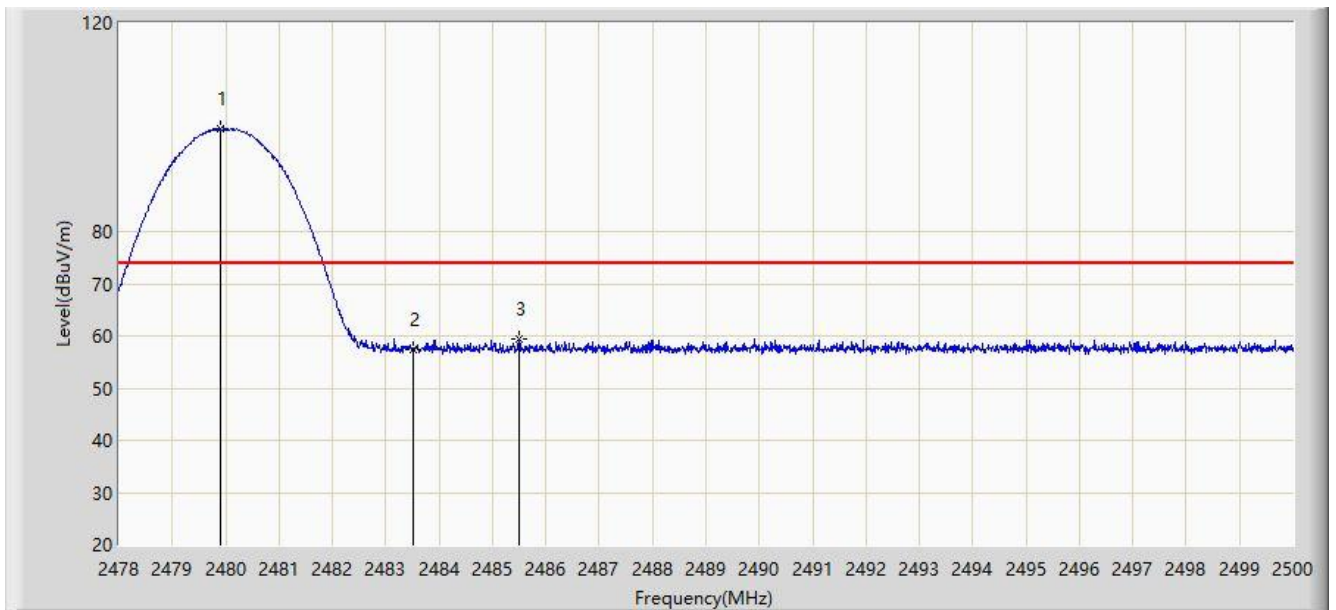

No	Flag	Mark	Frequency (MHz)	Measure Level (dBuV/m)	Reading Level (dBuV)	Over Limit (dB)	Limit (dBuV/m)	Factor (dB)	Type
1		*	2479.892	99.672	67.347	N/A	N/A	32.325	PK
2			2483.500	57.320	24.981	-16.680	74.000	32.340	PK
3			2485.502	59.354	27.007	-14.646	74.000	32.347	PK

Note: Measure Level (dB μ V/m) = Reading Level (dB μ V) + Factor (dB)

Factor (dB) = Cable Loss (dB) + Antenna Factor (dB/m)

Site: AC1	Time: 2019/03/02 - 03:29
Limit: FCC_Part15_Band Edge(3m)	Engineer: Messiah Li
Probe: BBHA9120D_1-18GHz	Polarity: Vertical
EUT: Communication Module	Power: DC 3.3V
Note: Transmit by 2DH5 at channel 2480MHz	

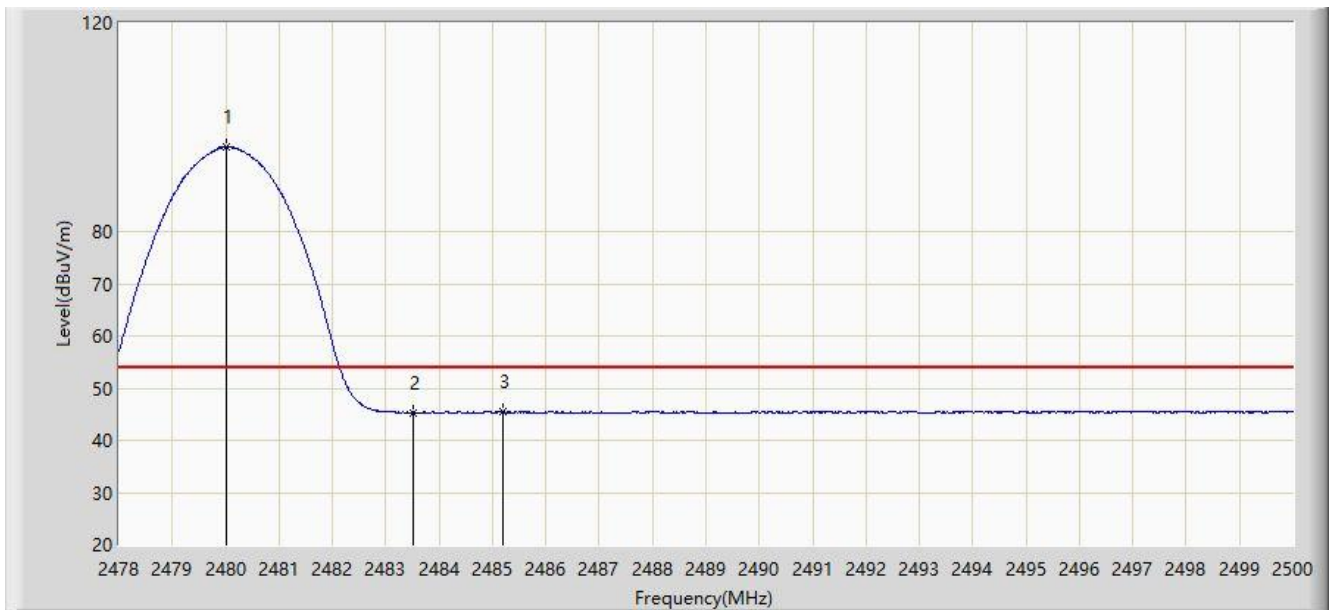

No	Flag	Mark	Frequency (MHz)	Measure Level (dBuV/m)	Reading Level (dBuV)	Over Limit (dB)	Limit (dBuV/m)	Factor (dB)	Type
1		*	2480.002	96.164	63.839	N/A	N/A	32.325	AV
2			2483.500	45.362	13.023	-8.638	54.000	32.340	AV
3			2485.194	45.565	13.219	-8.435	54.000	32.346	AV

Note: Measure Level (dB μ V/m) = Reading Level (dB μ V) + Factor (dB)

Factor (dB) = Cable Loss (dB) + Antenna Factor (dB/m)

Site: AC1	Time: 2019/03/02 - 03:31
Limit: FCC_Part15_Band Edge(3m)	Engineer: Messiah Li
Probe: BBHA9120D_1-18GHz	Polarity: Horizontal
EUT: Communication Module	Power: DC 3.3V
Note: Transmit by 3DH5 at channel 2402MHz	

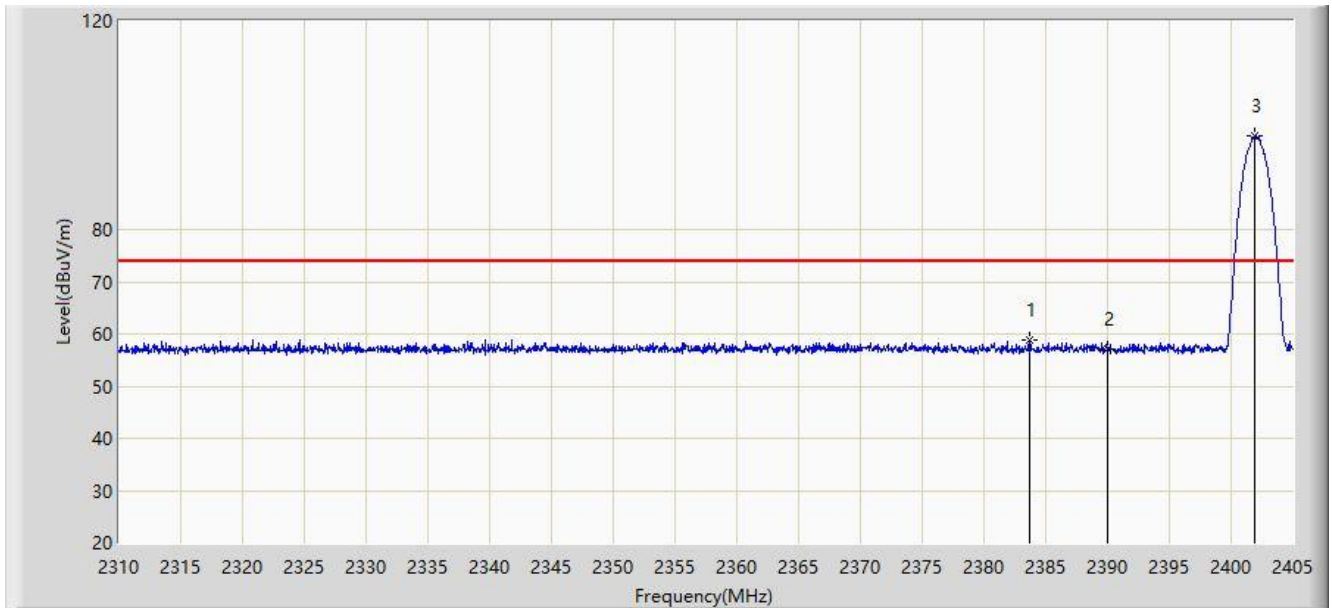

No	Flag	Mark	Frequency (MHz)	Measure Level (dBuV/m)	Reading Level (dBuV)	Over Limit (dB)	Limit (dBuV/m)	Factor (dB)	Type
1			2383.720	58.783	26.448	-15.217	74.000	32.335	PK
2			2390.000	57.235	24.908	-16.765	74.000	32.327	PK
3		*	2401.960	97.918	65.613	N/A	N/A	32.305	PK

Note: Measure Level (dB μ V/m) = Reading Level (dB μ V) + Factor (dB)

Factor (dB) = Cable Loss (dB) + Antenna Factor (dB/m)

Site: AC1	Time: 2019/03/02 - 03:33
Limit: FCC_Part15_Band Edge(3m)	Engineer: Messiah Li
Probe: BBHA9120D_1-18GHz	Polarity: Horizontal
EUT: Communication Module	Power: DC 3.3V
Note: Transmit by 3DH5 at channel 2402MHz	

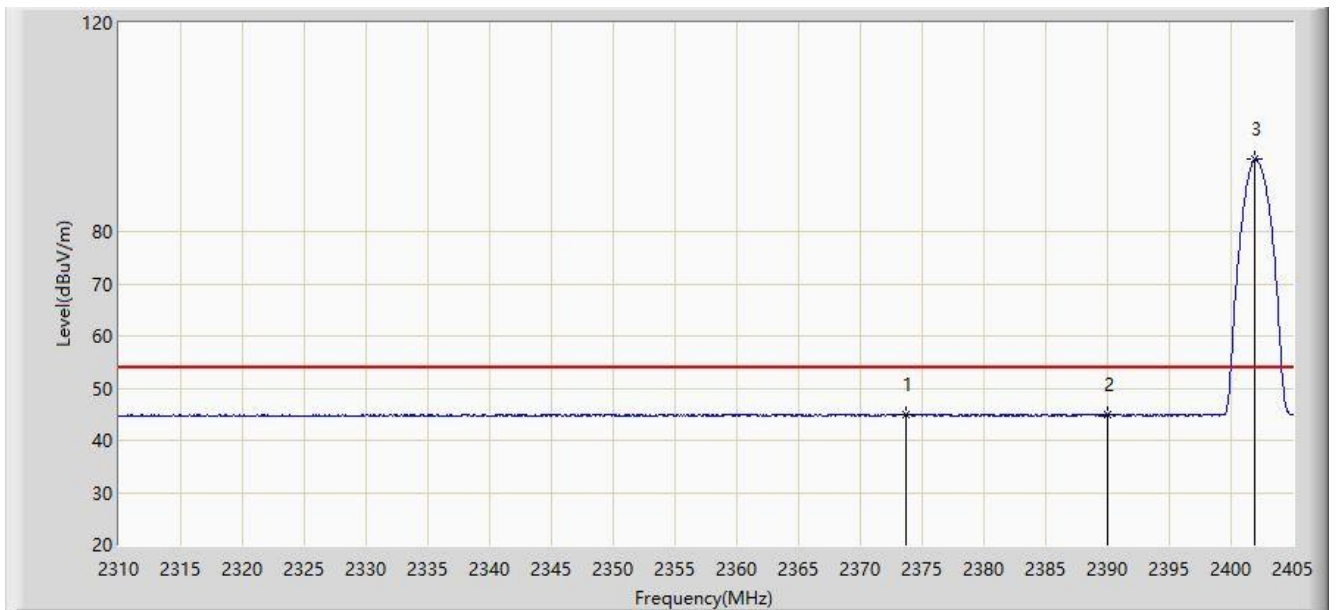

No	Flag	Mark	Frequency (MHz)	Measure Level (dBuV/m)	Reading Level (dBuV)	Over Limit (dB)	Limit (dBuV/m)	Factor (dB)	Type
1			2373.745	45.068	12.717	-8.932	54.000	32.351	AV
2			2390.000	44.832	12.505	-9.168	54.000	32.327	AV
3		*	2401.960	93.854	61.549	N/A	N/A	32.305	AV

Note: Measure Level (dB μ V/m) = Reading Level (dB μ V) + Factor (dB)

Factor (dB) = Cable Loss (dB) + Antenna Factor (dB/m)

Site: AC1	Time: 2019/03/02 - 03:34
Limit: FCC_Part15_Band Edge(3m)	Engineer: Messiah Li
Probe: BBHA9120D_1-18GHz	Polarity: Vertical
EUT: Communication Module	Power: DC 3.3V
Note: Transmit by 3DH5 at channel 2402MHz	

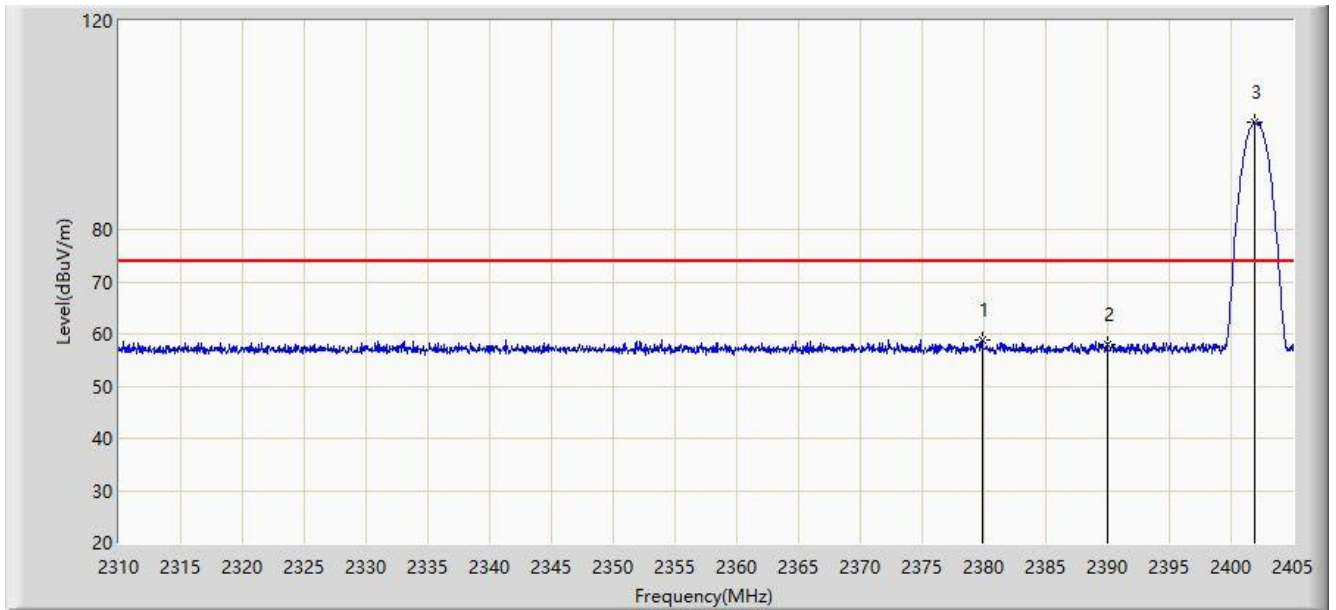

No	Flag	Mark	Frequency (MHz)	Measure Level (dBuV/m)	Reading Level (dBuV)	Over Limit (dB)	Limit (dBuV/m)	Factor (dB)	Type
1			2379.825	58.949	26.608	-15.051	74.000	32.340	PK
2			2390.000	57.941	25.614	-16.059	74.000	32.327	PK
3		*	2401.865	100.598	68.293	N/A	N/A	32.305	PK

Note: Measure Level (dB μ V/m) = Reading Level (dB μ V) + Factor (dB)

Factor (dB) = Cable Loss (dB) + Antenna Factor (dB/m)

Site: AC1	Time: 2019/03/02 - 03:35
Limit: FCC_Part15_Band Edge(3m)	Engineer: Messiah Li
Probe: BBHA9120D_1-18GHz	Polarity: Vertical
EUT: Communication Module	Power: DC 3.3V
Note: Transmit by 3DH5 at channel 2402MHz	

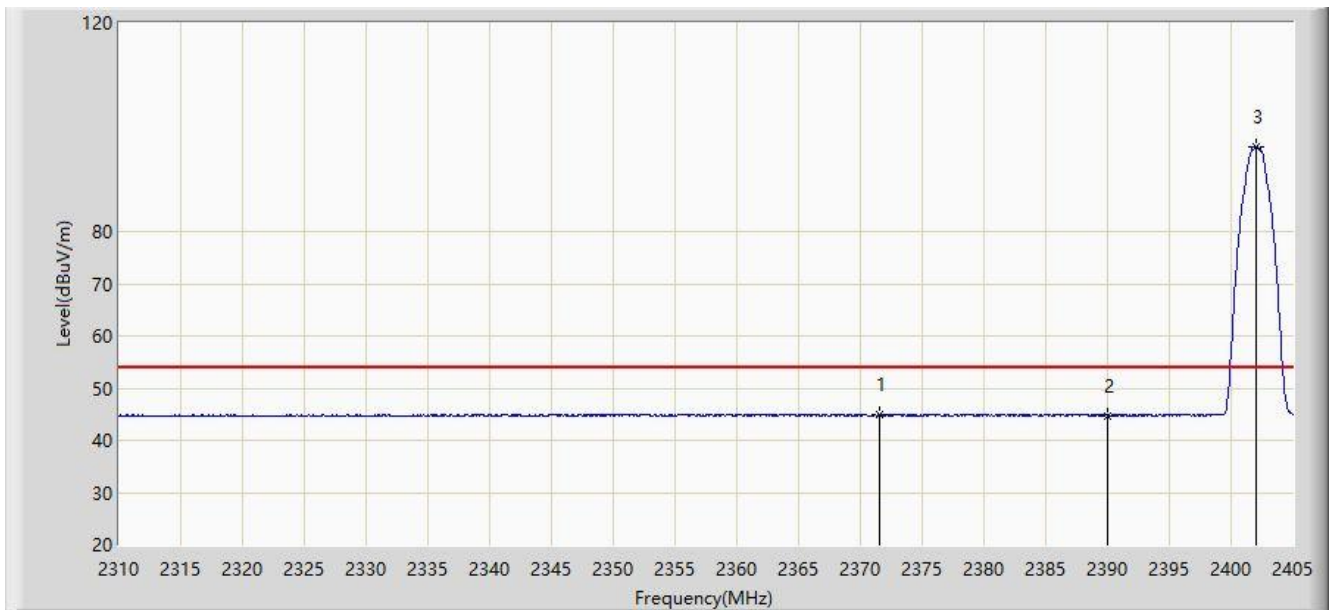

No	Flag	Mark	Frequency (MHz)	Measure Level (dBuV/m)	Reading Level (dBuV)	Over Limit (dB)	Limit (dBuV/m)	Factor (dB)	Type
1			2371.607	45.004	12.649	-8.996	54.000	32.355	AV
2			2390.000	44.772	12.445	-9.228	54.000	32.327	AV
3		*	2402.008	96.313	64.009	N/A	N/A	32.305	AV

Note: Measure Level (dB μ V/m) = Reading Level (dB μ V) + Factor (dB)

Factor (dB) = Cable Loss (dB) + Antenna Factor (dB/m)

Site: AC1	Time: 2019/03/02 - 03:37
Limit: FCC_Part15_Band Edge(3m)	Engineer: Messiah Li
Probe: BBHA9120D_1-18GHz	Polarity: Horizontal
EUT: Communication Module	Power: DC 3.3V
Note: Transmit by 3DH5 at channel 2480MHz	

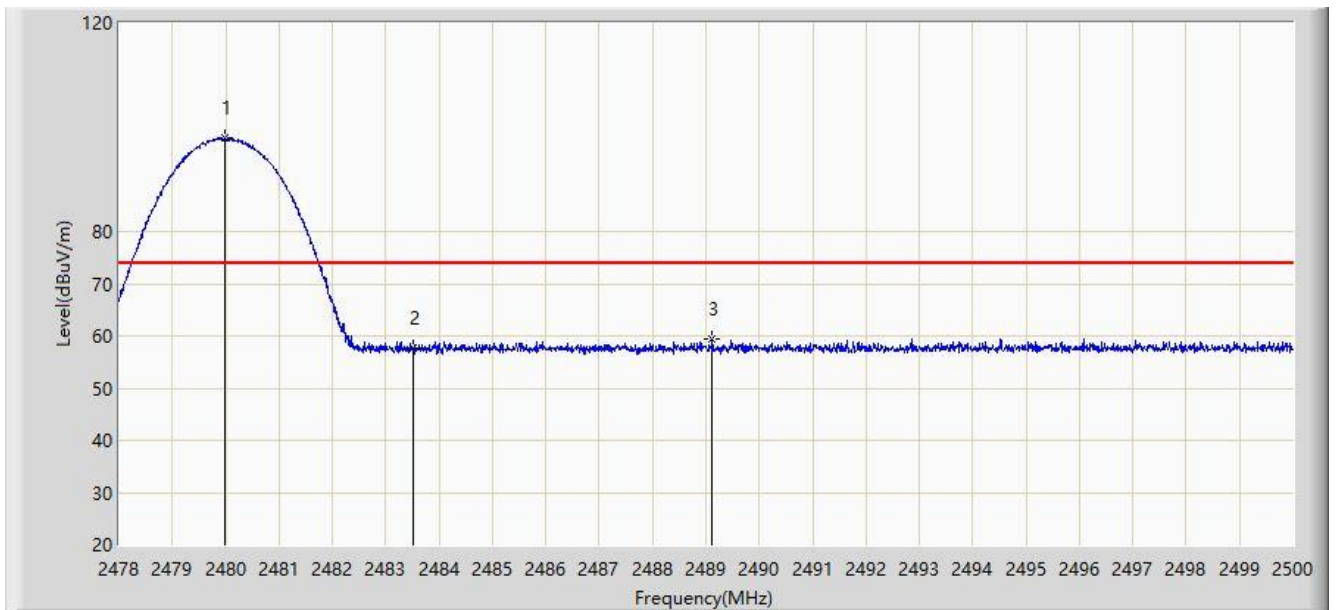

No	Flag	Mark	Frequency (MHz)	Measure Level (dBuV/m)	Reading Level (dBuV)	Over Limit (dB)	Limit (dBuV/m)	Factor (dB)	Type
1		*	2479.980	97.889	65.564	N/A	N/A	32.325	PK
2			2483.500	57.545	25.206	-16.455	74.000	32.340	PK
3			2489.121	59.339	26.978	-14.661	74.000	32.361	PK

Note: Measure Level (dB μ V/m) = Reading Level (dB μ V) + Factor (dB)

Factor (dB) = Cable Loss (dB) + Antenna Factor (dB/m)

Site: AC1	Time: 2019/03/02 - 03:39
Limit: FCC_Part15_Band Edge(3m)	Engineer: Messiah Li
Probe: BBHA9120D_1-18GHz	Polarity: Horizontal
EUT: Communication Module	Power: DC 3.3V
Note: Transmit by 3DH5 at channel 2480MHz	

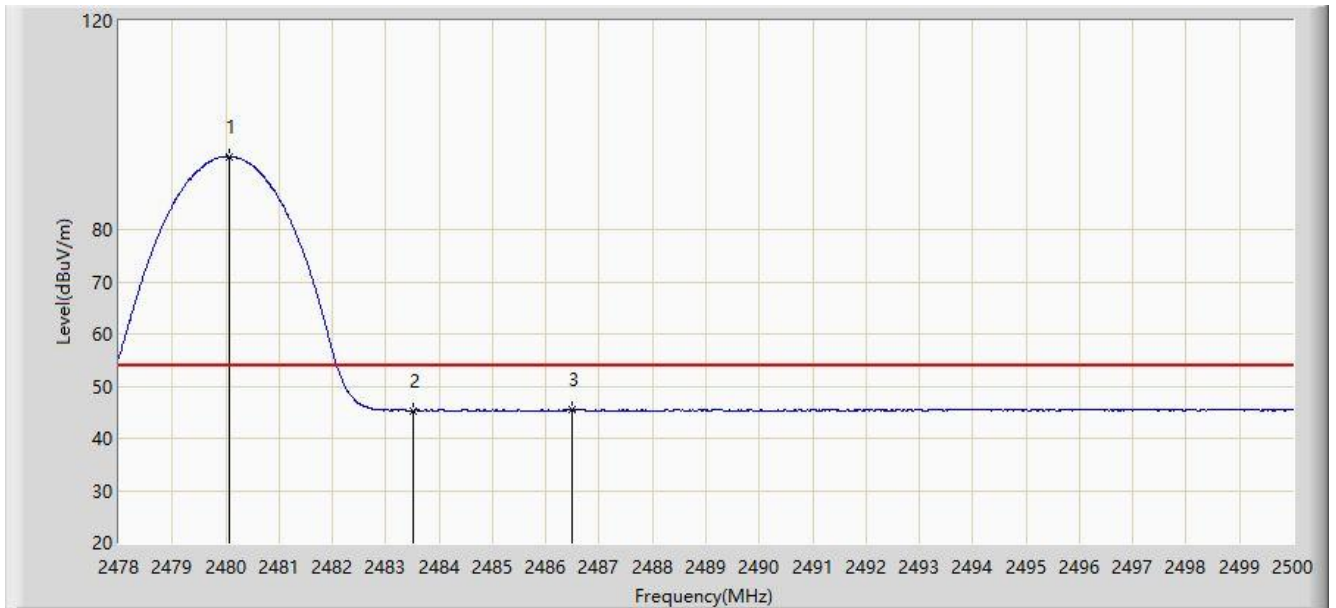

No	Flag	Mark	Frequency (MHz)	Measure Level (dBuV/m)	Reading Level (dBuV)	Over Limit (dB)	Limit (dBuV/m)	Factor (dB)	Type
1		*	2480.079	94.038	61.712	N/A	N/A	32.325	AV
2			2483.500	45.239	12.900	-8.761	54.000	32.340	AV
3			2486.503	45.375	13.024	-8.625	54.000	32.351	AV

Note: Measure Level (dB μ V/m) = Reading Level (dB μ V) + Factor (dB)

Factor (dB) = Cable Loss (dB) + Antenna Factor (dB/m)

Site: AC1	Time: 2019/03/02 - 03:40
Limit: FCC_Part15_Band Edge(3m)	Engineer: Messiah Li
Probe: BBHA9120D_1-18GHz	Polarity: Vertical
EUT: Communication Module	Power: DC 3.3V
Note: Transmit by 3DH5 at channel 2480MHz	

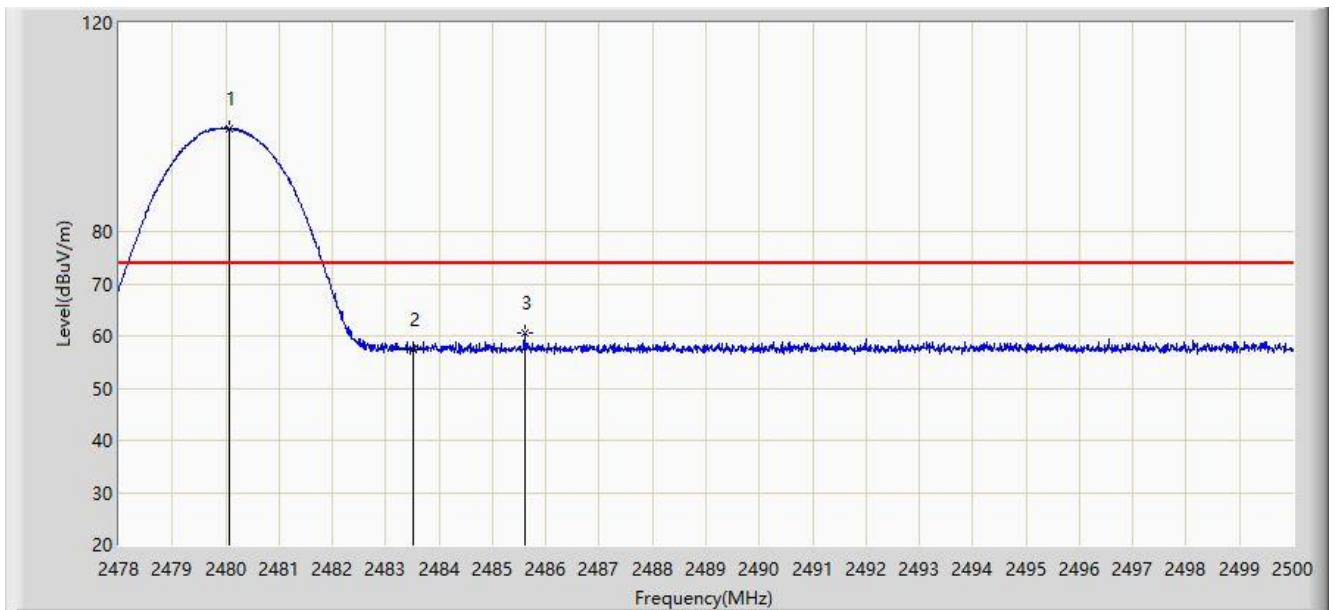

No	Flag	Mark	Frequency (MHz)	Measure Level (dBuV/m)	Reading Level (dBuV)	Over Limit (dB)	Limit (dBuV/m)	Factor (dB)	Type
1		*	2480.079	99.674	67.348	N/A	N/A	32.325	PK
2			2483.500	57.474	25.135	-16.526	74.000	32.340	PK
3			2485.601	60.703	28.356	-13.297	74.000	32.347	PK

Note: Measure Level (dB μ V/m) = Reading Level (dB μ V) + Factor (dB)

Factor (dB) = Cable Loss (dB) + Antenna Factor (dB/m)

Site: AC1	Time: 2019/03/02 - 03:41
Limit: FCC_Part15_Band Edge(3m)	Engineer: Messiah Li
Probe: BBHA9120D_1-18GHz	Polarity: Vertical
EUT: Communication Module	Power: DC 3.3V
Note: Transmit by 3DH5 at channel 2480MHz	

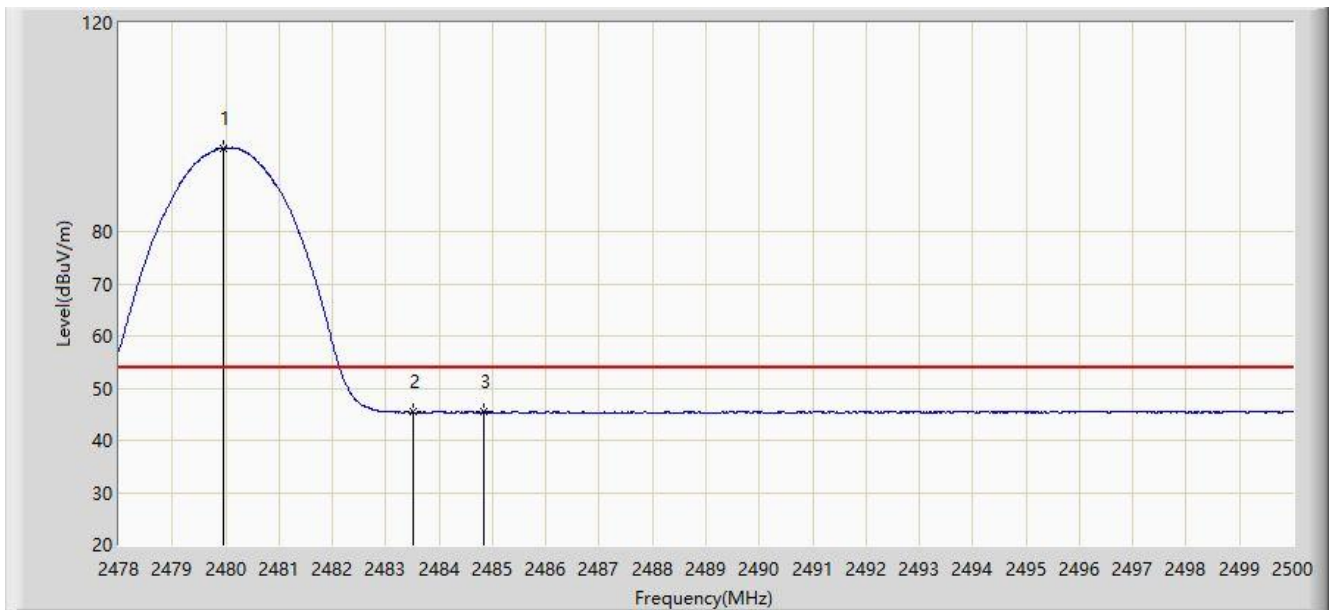

No	Flag	Mark	Frequency (MHz)	Measure Level (dBuV/m)	Reading Level (dBuV)	Over Limit (dB)	Limit (dBuV/m)	Factor (dB)	Type
1		*	2479.969	96.007	63.682	N/A	N/A	32.325	AV
2			2483.500	45.420	13.081	-8.580	54.000	32.340	AV
3			2484.831	45.471	13.127	-8.529	54.000	32.344	AV

Note: Measure Level (dB μ V/m) = Reading Level (dB μ V) + Factor (dB)

Factor (dB) = Cable Loss (dB) + Antenna Factor (dB/m)

6.11. AC Conducted Emissions Measurement

6.11.1. Test Limit

FCC Part 15 Subpart C Paragraph 15.207 Limits		
Frequency (MHz)	QP (dBuV)	AV (dBuV)
0.15 ~ 0.50	66 ~ 56	56 ~ 46
0.50 ~ 5.0	56	46
5.0 ~ 30	60	50

Note 1: The lower limit shall apply at the transition frequencies.

Note 2: The limit decreases linearly with the logarithm of the frequency in the range 0.15MHz to 0.5MHz.

6.11.2. Test Setup

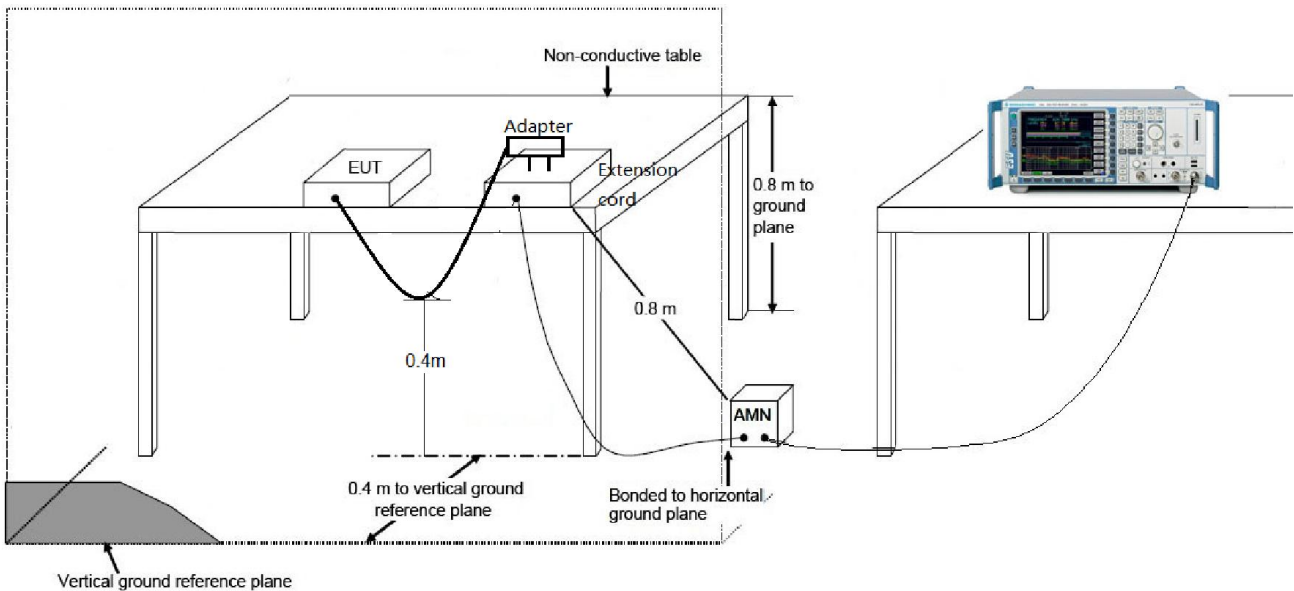

6.11.3. Test Result

Power supply of this device is by DC Source, so this item is not assessed.

7. CONCLUSION

The data collected relate only the item(s) tested and show that the **Communication Module** is in compliance with Part 15C of the FCC Rules and RSS-247 Issue 2 of ISED Rules.

The End

Appendix A – Test Setup Photograph

Refer to “ 1901WSU002-UT” file.

Appendix B – EUT Photograph

Refer to “1901WSU002-UE” file.