



# RADIO TEST REPORT

**Test Report No. : 13004393S-A-R2**

**Applicant** : Murata Manufacturing Co., Ltd.  
**Type of Equipment** : Communication Module  
**Model No.** : Type1VY  
**FCC ID** : VPYLB1VY  
**Test regulation** : **FCC Part 15 Subpart C: 2019**  
\* Wireless LAN (2.4 GHz band) & Bluetooth low energy part  
**Test Result** : **Complied (Refer to SECTION 3.2)**

1. This test report shall not be reproduced in full or partial, without the written approval of UL Japan, Inc.
2. The results in this report apply only to the sample tested.
3. This sample tested is in compliance with the limits of the above regulation.
4. The test results in this test report are traceable to the national or international standards.
5. This test report must not be used by the customer to claim product certification, approval, or endorsement by the A2LA accreditation body.
6. This test report covers Radio technical requirements.  
It does not cover administrative issues such as Manual or non-Radio test related Requirements. (if applicable)
7. The all test items in this test report are conducted by UL Japan, Inc. Shonan EMC Lab.
8. The opinions and the interpretations to the result of the description in this report are outside scopes where UL Japan has been accredited.
9. The information provided from the customer for this report is identified in SECTION 1.
10. This report is a revised version of 13004393S-A-R1. 13004393S-A-R1 is replaced with this report.

**Date of test:** September 3 to 23, 2019

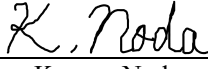
**Representative test engineer:**   
Kazuya Noda  
Engineer  
Consumer Technology Division

**Approved by:**   
Hikaru Shirasawa  
Engineer  
Consumer Technology Division



CERTIFICATE 1266.03

- The testing in which "Non-accreditation" is displayed is outside the accreditation scopes in UL Japan.  
 There is no testing item of "Non-accreditation".

**UL Japan, Inc.**  
**Shonan EMC Lab.**

1-22-3 Megumigaoka, Hiratsuka-shi, Kanagawa-ken, 259-1220 JAPAN  
Telephone : +81 463 50 6400  
Facsimile : +81 463 50 6401

## REVISION HISTORY

### Original Test Report No.: 13004393S-A

Revision	Test report No.	Date	Page revised	Contents
- (Original)	13004393S-A	December 2, 2019	-	-
1	13004393S-A-R1	December 11, 2019	11	Addition to Spurious Emission: “Tx BT LE with Tx 11ac-40 5190 MHz, high power” “Chain-0 + Chain-1” “2402 MHz 2440 MHz 2480 MHz”
2	13004393S-A-R2	December 23, 2019	7	Addition: “Additional information of specification: ... except the mode of Config.5.”

---

**UL Japan, Inc.**

**Shonan EMC Lab.**

1-22-3 Megumigaoka, Hiratsuka-shi, Kanagawa-ken, 259-1220 JAPAN

Telephone : +81 463 50 6400

Facsimile : +81 463 50 6401

## Reference: Abbreviations (Including words undescribed in this report)

A2LA	The American Association for Laboratory Accreditation	NS	No signal detect.
AC	Alternating Current	NSA	Normalized Site Attenuation
AFH	Adaptive Frequency Hopping	NVLAP	National Voluntary Laboratory Accreditation Program
AM	Amplitude Modulation	OBW	Occupied Band Width
Amp, AMP	Amplifier	OFDM	Orthogonal Frequency Division Multiplexing
ANSI	American National Standards Institute	P/M	Power meter
Ant, ANT	Antenna	PCB	Printed Circuit Board
AP	Access Point	PER	Packet Error Rate
Atten., ATT	Attenuator	PHY	Physical Layer
AV	Average	PK	Peak
BPSK	Binary Phase-Shift Keying	PN	Pseudo random Noise
BR	Bluetooth Basic Rate	PRBS	Pseudo-Random Bit Sequence
BT	Bluetooth	PSD	Power Spectral Density
BT LE	Bluetooth Low Energy	QAM	Quadrature Amplitude Modulation
BW	BandWidth	QP	Quasi-Peak
Cal Int	Calibration Interval	QPSK	Quadri-Phase Shift Keying
CCK	Complementary Code Keying	RBW	Resolution Band Width
Ch., CH	Channel	RDS	Radio Data System
CISPR	Comite International Special des Perturbations Radioelectriques	RE	Radio Equipment
CW	Continuous Wave	RF	Radio Frequency
DBPSK	Differential BPSK	RMS	Root Mean Square
DC	Direct Current	RSS	Radio Standards Specifications
DFS	Dynamic Frequency Selection	Rx	Receiving
DQPSK	Differential QPSK	SA, S/A	Spectrum Analyzer
DSSS	Direct Sequence Spread Spectrum	SG	Signal Generator
EDR	Enhanced Data Rate	SVSWR	Site-Voltage Standing Wave Ratio
EIRP, e.i.r.p.	Equivalent Isotropically Radiated Power	TR	Test Receiver
EMC	ElectroMagnetic Compatibility	Tx	Transmitting
EMI	ElectroMagnetic Interference	VBW	Video BandWidth
EN	European Norm	Vert.	Vertical
ERP, e.r.p.	Effective Radiated Power	WLAN	Wireless LAN
EU	European Union		
EUT	Equipment Under Test		
Fac.	Factor		
FCC	Federal Communications Commission		
FHSS	Frequency Hopping Spread Spectrum		
FM	Frequency Modulation		
Freq.	Frequency		
GFSK	Gaussian Frequency-Shift Keying		
GNSS	Global Navigation Satellite System		
GPS	Global Positioning System		
Hori.	Horizontal		
ICES	Interference-Causing Equipment Standard		
IEC	International Electrotechnical Commission		
IEEE	Institute of Electrical and Electronics Engineers		
IF	Intermediate Frequency		
ILAC	International Laboratory Accreditation Conference		
ISED	Innovation, Science and Economic Development Canada		
ISO	International Organization for Standardization		
JAB	Japan Accreditation Board		
LAN	Local Area Network		
LIMS	Laboratory Information Management System		
MCS	Modulation and Coding Scheme		
MRA	Mutual Recognition Arrangement		
NIST	National Institute of Standards and Technology		

---

**UL Japan, Inc.**

**Shonan EMC Lab.**

1-22-3 Megumigaoka, Hiratsuka-shi, Kanagawa-ken, 259-1220 JAPAN

Telephone : +81 463 50 6400

Facsimile : +81 463 50 6401

---

<b>CONTENTS</b>	<b>PAGE</b>
<b>SECTION 1: Customer information.....</b>	<b>5</b>
<b>SECTION 2: Equipment under test (E.U.T.).....</b>	<b>5</b>
<b>SECTION 3: Test specification, procedures &amp; results.....</b>	<b>8</b>
<b>SECTION 4: Operation of E.U.T. during testing.....</b>	<b>11</b>
<b>SECTION 5: Conducted Emission.....</b>	<b>17</b>
<b>SECTION 6: Radiated Spurious Emission .....</b>	<b>18</b>
<b>SECTION 7: Antenna Terminal Conducted Tests.....</b>	<b>22</b>
<b>APPENDIX 1: Test data .....</b>	<b>23</b>
Conducted Emission .....	23
6 dB Bandwidth and 99 % Occupied Bandwidth.....	28
Maximum Peak Output Power .....	35
Average Output Power .....	48
Burst rate confirmation .....	53
Radiated Spurious Emission .....	55
Conducted Spurious Emission .....	118
Power Density .....	122
<b>APPENDIX 2: Test instruments .....</b>	<b>140</b>
<b>APPENDIX 3: Photographs of test setup .....</b>	<b>142</b>
Conducted Emission .....	142
Radiated Spurious Emission .....	144
Pre-check of Worst Case Position.....	146

## **SECTION 1: Customer information**

Company Name : Murata Manufacturing Co., Ltd.  
Address : 1-10-1 Higashikotari, Nagaokakyo-shi, Kyoto 617-8555 Japan  
Telephone Number : +81-75-955-6736  
Facsimile Number : +81-75-955-6634  
Contact Person : Motoo Hayashi

The information provided from the customer is as follows;

- Applicant, Type of Equipment, Model No., FCC ID on the cover and other relevant pages
- Operating/Test Mode(s) (Mode(s)) on all the relevant pages
- SECTION 1: Customer information
- SECTION 2: Equipment under test (E.U.T.)
- SECTION 4: Operation of E.U.T. during testing

\* The laboratory is exempted from liability of any test results affected from the above information in SECTION 2 and 4.

## **SECTION 2: Equipment under test (E.U.T.)**

### **2.1 Identification of E.U.T.**

Type of Equipment : Communication Module  
Model No. : Type1VY  
Serial No. : Refer to SECTION 4.2  
Rating : VDD\_3P3, SWREG\_IN, VDD\_FEM:  
Typ.: DC 3.3 V, Min.: DC 3.135 V, Max: DC 3.465 V  
VDDIO\_GPIO, VDDIO\_AO:  
Typ.: DC 3.3 V, Min.: DC 3.14 V, Max: DC 3.46 V  
Receipt Date of Sample : August 25, 2019  
(Information from test lab.)  
Country of Mass-production : China, Japan  
Condition of EUT : Production prototype  
(Not for Sale: This sample is equivalent to mass-produced items.)  
Modification of EUT : No Modification by the test lab.

## 2.2 Product Description

Model: Type1VY (referred to as the EUT in this report) is a Communication Module.

Clock frequency(ies) in the system : 48 MHz

### Radio Specification

Equipment type	:	Transceiver
Frequency of operation	:	2.4 GHz: 2402 MHz – 2480 MHz (Bluetooth BDR/EDR/Low Energy (LE)) 2412 MHz – 2462 MHz (IEEE 802.11b, 11g, 11n-20) U-NII-1: 5180 MHz – 5240 MHz (IEEE 802.11a, 11n-20, 11ac-20) 5190 MHz – 5230 MHz (IEEE 802.11n-40, 11ac-40) 5210 MHz (IEEE 802.11ac-80) U-NII-2A: 5260 MHz – 5320 MHz (IEEE 802.11a, 11n-20, 11ac-20) 5270 MHz – 5310 MHz (IEEE 802.11n-40, 11ac-40) 5290 MHz (IEEE 802.11ac-80) U-NII-2B: 5500 MHz – 5720 MHz (IEEE 802.11a, 11n-20, 11ac-20) 5510 MHz – 5710 MHz (IEEE 802.11n-40, 11ac-40) 5530 MHz – 5690 MHz (IEEE 802.11ac-80) U-NII-3: 5745 MHz – 5825 MHz (IEEE 802.11a, 11n-20, 11ac-20) 5755 MHz – 5795 MHz (IEEE 802.11n-40, 11ac-40) 5775 MHz (IEEE 802.11ac-80)
Bandwidth	:	20 MHz (IEEE 802.11a/b/g/n/ac), 40 MHz (IEEE 802.11n/ac), 80 MHz (IEEE 802.11ac), 79 MHz (Bluetooth BDR/EDR), 1 MHz (Bluetooth LE)
Channel spacing	:	5 MHz (Wi-Fi 2.4 GHz), 20 MHz/40 MHz/80 MHz (Wi-Fi 5 GHz), 1 MHz (Bluetooth BDR/EDR), 2 MHz (Bluetooth LE)
Type of modulation	:	DSSS (IEEE 802.11b), OFDM (IEEE 802.11a/g/n/ac), FHSS (Bluetooth BDR/EDR), GFSK (Bluetooth LE)
Antenna type	:	2.4 GHz: Monopole antenna/Slot antenna/Dual monopole antenna 5 GHz: Slot antenna/ Dual monopole antenna
Antenna connector type	:	Spring
Antenna gain	:	Chain-0: [2.4 GHz] Dual Monopole antenna: +0.93 dBi [5 GHz] Dual Monopole antenna: +1.04 dBi Chain-1: [2.4 GHz] Dual Monopole antenna: +0.93 dBi [2.4 GHz] Slot antenna: +1.97 dBi [2.4 GHz] Monopole antenna: +1.98 dBi [5 GHz] Dual Monopole antenna: +1.04 dBi [5 GHz] Slot antenna: +1.98 dBi
ITU code	:	F1D, G1D (Bluetooth BDR/EDR), F1D (Bluetooth LE) D1D, G1D (IEEE802.11b/g/n/a/ac)
Operation temperature range	:	-30 deg. C to +85 deg. C

\* The EUT has 2-type of jig for the measurement; PCB\_A and PCB\_B and the corresponding antenna is different. Refer to section 4.2 for details of the combination.

Additional information of specification:

**serial no. A-\*\***

The radio output port 0 of the radio circuit is configured with a path such as a chip resistor so that it can be connected only to the connector P2 on the jig board.

The wireless circuit port 1 of the wireless circuit is configured with a chip resistor and so on so that it can be connected only to connector P7 on the jig board.

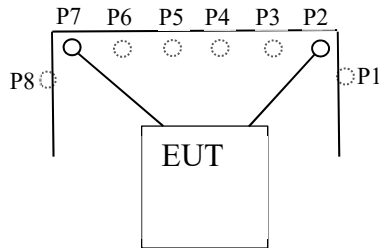

**serial no. B-\*\***

The radio output port 0 of the radio circuit is configured with a path such as a chip resistor so that it can be connected only to the connector P2 on the jig board.

The radio output port 1 of the radio circuit is configured with a path such as a chip resistor so that it can be connected to the jig board connector P5 and connector P6 via duplexer in the jig board.

(\* P5 is for 2.4 GHz band signal only. P6 is for 5 GHz band signal only.)

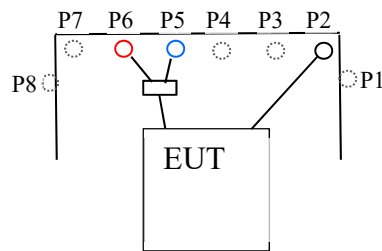

**Transmission pattern**

		Config. 1	Config. 2	Config. 3	Config. 4	Config. 5
chain 0	Bluetooth	-	-	transmit	transmit	transmit
	WLAN 2.4 GHz	-	transmit	-	-	-
	WLAN 5 GHz	transmit	-	-	transmit	-
chain 1	WLAN 2.4 GHz	-	transmit	-	-	transmit
	WLAN 5 GHz	transmit	-	-	transmit	-

Bluetooth mode is only chain 0 output.

WLAN all mode is simultaneous transmission at chain 0 and chain 1 output except the mode of Config.5.

**UL Japan, Inc.**

**Shonan EMC Lab.**

1-22-3 Megumigaoka, Hiratsuka-shi, Kanagawa-ken, 259-1220 JAPAN

Telephone : +81 463 50 6400

Facsimile : +81 463 50 6401

## **SECTION 3: Test specification, procedures & results**

### **3.1 Test Specification**

Test Specification : FCC Part 15 Subpart C  
FCC Part 15 final revised on July 19, 2019 and effective August 19, 2019 except 15.258

Title : FCC 47 CFR Part 15 Radio Frequency Device Subpart C Intentional Radiators  
Section 15.207 Conducted limits  
Section 15.247 Operation within the bands 902-928 MHz, 2400-2483.5 MHz,  
and 5725-5850 MHz

### **3.2 Procedures and results**

Item	Test Procedure	Specification	Worst margin	Results	Remarks
Conducted Emission	FCC: ANSI C63.10-2013 6. Standard test methods ----- ISED: RSS-Gen 8.8	FCC: Section 15.207 ----- ISED: RSS-Gen 8.8	16.3 dB, 9.35388 MHz, N, AV Mode: Tx BT LE 2402 MHz EUT Serial No.: A-9	Complied a)	-
6 dB Bandwidth	FCC: KDB 558074 D01 15.247 Meas Guidance v05r02 ----- ISED: -	FCC: Section 15.247(a)(2) ----- ISED: RSS-247 5.2(a)	See data.	Complied b)	Conducted
Maximum Peak Output Power	FCC: KDB 558074 D01 15.247 Meas Guidance v05r02 ----- ISED: RSS-Gen 6.12	FCC: Section 15.247(b)(3) ----- ISED: RSS-247 5.4(d)		Complied c)	Conducted
Power Density	FCC: KDB 558074 D01 15.247 Meas Guidance v05r02 ----- ISED: -	FCC: Section 15.247(e) ----- ISED: RSS-247 5.2(b)		Complied d)	Conducted
Spurious Emission Restricted Band Edges	FCC: KDB 558074 D01 15.247 Meas Guidance v05r02 ----- ISED: RSS-Gen 6.13	FCC: Section 15.247(d) ----- ISED: RSS-247 5.5 RSS-Gen 8.9 RSS-Gen 8.10		1.7 dB 2483.500 MHz, AV, Vert. Tx 11g 2462 MHz EUT Serial No.: B-2 Antenna Chain-0: 2.4 GHz / 5 GHz Dual Monopole Antenna Chain-1: 2.4 GHz Slot Antenna	Complied# e), f)

Note: UL Japan, Inc.'s EMI Work Procedures No. 13-EM-W0420 and 13-EM-W0422.

\*1) Radiated test was selected over 30 MHz based on section 15.247(d) and KDB 558074 D01 15.247 Meas Guidance v05r02 8.5 and 8.6.

- a) Refer to APPENDIX 1 (data of Conducted Emission)  
b) Refer to APPENDIX 1 (data of 6 dB Bandwidth and 99 % Occupied Bandwidth)  
c) Refer to APPENDIX 1 (data of Maximum Peak Output Power)  
d) Refer to APPENDIX 1 (data of Power Density)  
e) Refer to APPENDIX 1 (data of Conducted Spurious Emission)  
f) Refer to APPENDIX 1 (data of Radiated Spurious Emission)

Symbols:

Complied The data of this test item has enough margin, more than the measurement uncertainty.

Complied# The data of this test item meets the limits unless the measurement uncertainty is taken into consideration.

\* In case any questions arise about test procedure, ANSI C63.10: 2013 is also referred.

**UL Japan, Inc.**

**Shonan EMC Lab.**

1-22-3 Megumigaoka, Hiratsuka-shi, Kanagawa-ken, 259-1220 JAPAN

Telephone : +81 463 50 6400

Facsimile : +81 463 50 6401



**FCC Part 15.31 (e)**

The EUT has the power supply regulator. However one of the input voltages to RF part doesn't go through the regulator. The stable voltage will be supplied by the end product, which will be required to have a power supply regulator. Therefore, the EUT complies with the requirement.

**FCC Part 15.203/212**

The EUT has a unique coupling/antenna connector (U.FL). Therefore the equipment complies with the requirement.

**3.3 Addition to standard**

Item	Test Procedure	Specification	Worst margin	Results	Remarks
99 % Occupied Bandwidth	RSS-Gen 6.7	ISED: -	N/A	- a)	Conducted
a) Refer to APPENDIX 1 (data of 6 dB Bandwidth and 99 % Occupied Bandwidth)					

Other than above, no addition, exclusion nor deviation has been made from the standard.

**3.4 Uncertainty**

There is no applicable rule of uncertainty in this applied standard. Therefore, the results are derived depending on whether or not laboratory uncertainty is applied.

The following uncertainties have been calculated to provide a confidence level of 95 % using a coverage factor  $k=2$ .

Shonan EMC Lab.

Item	Frequency range	Uncertainty (+/-)			
		No. 1 SAC / SR	No. 2 SAC / SR	No. 3 SAC / SR	No. 4 SAC / SR
Conducted emission (AC Mains) LISN	150 kHz-30 MHz	2.9 dB	2.8 dB	2.9 dB	2.9 dB
Radiated emission (Measurement distance: 3 m)	9 kHz-30 MHz	3.0 dB	3.0 dB	3.1 dB	-
	30 MHz-200 MHz	4.6 dB	4.6 dB	4.7 dB	-
	200 MHz-1 GHz	6.0 dB	6.0 dB	6.1 dB	-
	1 GHz-6 GHz	4.8 dB	4.8 dB	4.8 dB	-
	6 GHz-18 GHz	5.4 dB	5.4 dB	5.4 dB	-
Radiated emission (Measurement distance: 1 m)	18 GHz-40 GHz	5.6 dB	5.6 dB	5.6 dB	-
	1 GHz-18 GHz	5.7 dB	5.7 dB	5.7 dB	-
	18 GHz-40 GHz	5.9 dB	5.9 dB	5.9 dB	-

SAC=Semi-Anechoic Chamber

SR= Shielded Room is applied besides radiated emission

Antenna terminal test	Uncertainty (+/-)
Power Measurement above 1 GHz (Average Detector)_SPM-06	0.81 dB
Power Measurement above 1 GHz (Peak Detector)_SPM-06	1.53 dB
Power Measurement above 1 GHz (Average Detector)_SPM-07	0.95 dB
Power Measurement above 1 GHz (Peak Detector)_SPM-07	1.21 dB
Power Measurement above 1 GHz (Average Detector)_SPM-13	0.90 dB
Power Measurement above 1 GHz (Peak Detector)_SPM-13	1.04 dB
Spurious emission (Conducted) below 1GHz	1.8 dB
Spurious emission (Conducted) 1 GHz-3 GHz	1.7 dB
Spurious emission (Conducted) 3 GHz-18 GHz	2.3 dB
Spurious emission (Conducted) 18 GHz-26.5 GHz	2.4 dB
Spurious emission (Conducted) 26.5 GHz-40 GHz	2.4 dB
Bandwidth Measurement	0.61 %
Duty cycle and Time Measurement	0.012 %

### 3.5 Test Location

UL Japan, Inc. Shonan EMC Lab.

1-22-3, Megumigaoka, Hiratsuka-shi, Kanagawa-ken 259-1220 JAPAN

Telephone: +81 463 50 6400, Facsimile: +81 463 50 6401

A2LA Certificate Number: 1266.03 (FCC Test Firm Registration Number: 626366, ISED Lab Company Number: 2973D)

Test site	Width x Depth x Height (m)	Size of reference ground plane (m) / horizontal conducting plane	Maximum measurement distance
No.1 Semi-anechoic chamber	20.6 x 11.3 x 7.65	20.6 x 11.3	10 m
No.2 Semi-anechoic chamber	20.6 x 11.3 x 7.65	20.6 x 11.3	10 m
No.3 Semi-anechoic chamber	12.7 x 7.7 x 5.35	12.7 x 7.7	5 m
No.4 Semi-anechoic chamber	8.1 x 5.1 x 3.55	8.1 x 5.1	-
No.1 Shielded room	6.8 x 4.1 x 2.7	6.8 x 4.1	-
No.2 Shielded room	6.8 x 4.1 x 2.7	6.8 x 4.1	-
No.3 Shielded room	6.3 x 4.7 x 2.7	6.3 x 4.7	-
No.4 Shielded room	4.4 x 4.7 x 2.7	4.4 x 4.7	-
No.5 Shielded room	7.8 x 6.4 x 2.7	7.8 x 6.4	-
No.6 Shielded room	7.8 x 6.4 x 2.7	7.8 x 6.4	-
No.8 shielded room	3.45 x 5.5 x 2.4	3.45 x 5.5	-
No.1 Measurement room	2.55 x 4.1 x 2.5	-	-

### 3.6 Test data, Test instruments, and Test set up

Refer to APPENDIX.

## **SECTION 4: Operation of E.U.T. during testing**

### **4.1 Operating Mode(s)**

Test operating mode was determined as follows according to “Section 1 of 6 802.11 a/b/g/n testing - Managing Complex Regulatory Approvals - ” of TCB Council Workshop October 2009 .

<b>Mode</b>	<b>Remarks*</b>
IEEE 802.11b CDD (11b)	2 Mbps, PN9
IEEE 802.11g CDD (11g)	36 Mbps, PN9
IEEE 802.11n 20 MHz BW CDD (11n-20 CDD)	MCS 7, PN9
IEEE 802.11n 20 MHz BW MIMO (11n-20 MIMO)	MCS 15, PN9
Bluetooth Low Energy (BT LE)	PRBS9
*The worst condition was determined based on the test result of Maximum Peak Output Power	
*Power of the EUT was set by the software as follows; Power settings (PCB A_high power): 11b: 12 dBm (2412 MHz,2462 MHz), 11.5 dBm (2437 MHz) 11g: 12 dBm 11n-20 CDD, MIMO: 11.5 dBm  Power settings (PCB B_high power): All mode: 11.5 dBm Power settings (PCB A_low power): All mode: 7.5 dBm Power settings (PCB B_low power): All mode: 7 dBm  Power settings (PCB A): BT LE: fixed Power settings (PCB B): BT LE: fixed  Software: Tera Term, Version 4.87 QRCT Version 3.0.276.0	
* All tests are carried out with below power setting regarding worst case although typical power setting is following; 11b/11g/11n-20: 11 dBm BT LE: Fixed	
*This setting of software is the worst case. Any conditions under the normal use do not exceed the condition of setting. In addition, end users cannot change the settings of the output power of the product.	

**UL Japan, Inc.**

**Shonan EMC Lab.**

1-22-3 Megumigaoka, Hiratsuka-shi, Kanagawa-ken, 259-1220 JAPAN  
Telephone : +81 463 50 6400  
Facsimile : +81 463 50 6401

\*The details of Operating mode(s)

Test Item	Operating Mode *3)	Tested Antenna	Tested frequency
Conducted Emission *1)	Tx 11g, high power	Chain-0 + Chain-1	2412 MHz
	Tx BT LE	Chain-0	2402 MHz
Spurious Emission *1)	Tx 11b, high power	Chain-0 + Chain-1	2412 MHz
	Tx 11g, high power		2437 MHz
	Tx 11n-20 CDD, high power		2462 MHz
	Tx 11n-20 MIMO, high power	Chain-0	2402 MHz
Tx BT LE	2440 MHz		
		2480 MHz	
	Tx BT LE with Tx 11ac-40 5190 MHz, high power	Chain-0 + Chain-1	2402 MHz
			2440 MHz
			2480 MHz
6 dB Bandwidth *1) *2) 99 % Occupied Bandwidth *1) *2)	Tx 11b, high power	Chain-1	2412 MHz
	Tx 11g, high power		2437 MHz
	Tx 11n-20 CDD, high power		2462 MHz
	Tx 11n-20 MIMO, high power	Chain-0	2402 MHz
Tx BT LE	2440 MHz		
			2480 MHz
Maximum Peak Output Power Power Density *1) *2)	Tx 11b, high power	Chain-0 + Chain-1	2412 MHz
	Tx 11g, high power		2437 MHz
	Tx 11n-20 CDD, high power		2462 MHz
	Tx 11n-20 MIMO, high power	Chain-0 + Chain-1	2412 MHz
	Tx 11b, low power		2437 MHz
	Tx 11g, low power		2462 MHz
	Tx 11n-20 CDD, low power		2462 MHz
Tx 11n-20 MIMO, low power	Chain-0	2402 MHz	
Tx BT LE		2440 MHz	
			2480 MHz

\*1) The test was performed with high power settings as a representative mode.  
\*2) The test was conducted a PCB of the worst power as a representative.

## 4.2 Configuration and peripherals

### 1. WLAN

PCB A : Chain-0: Dual Monopole Antenna  
: Chain-1: Dual Monopole Antenna

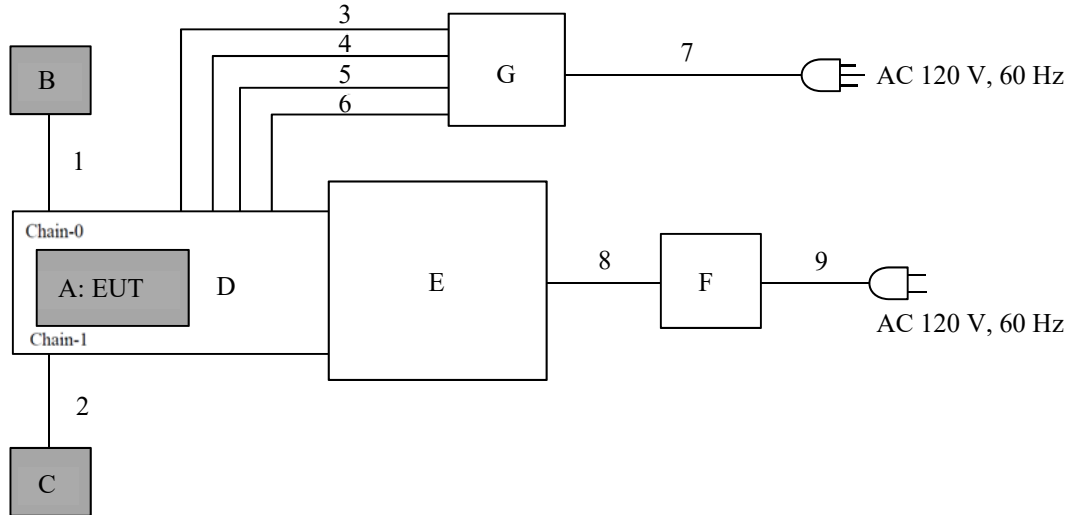

\* Cabling and setup(s) were taken into consideration and test data was taken under worse case conditions.

### Description of EUT and Support equipment

No.	Item	Model number	Serial number	Manufacturer	Remarks
A	Communication Module	Type1VY	A-1	Murata Manufacturing Co., Ltd.	EUT
B	Dual Monopole Antenna	M-d	No.1	SONY	EUT
C	Dual Monopole Antenna	M-d	No.2	SONY	EUT
D	PCB A	P2ML7925	A-1	Murata Manufacturing Co., Ltd.	-
E	Platform	iMX8	-	NXP Semiconductors	-
F	AC Adapter	EA10682N-120	-	EDACPOWER ELEC.	-
G	Power Supply (DC)	PAN35-10A	DE001677	KIKUSUI	-

### List of cables used

No.	Name	Length (m)	Shield		Remarks
			Cable	Connector	
1	Coaxial Cable	0.1	Shielded	Shielded	-
2	Coaxial Cable	0.1	Shielded	Shielded	-
3	DC Cable	0.7 + 2.0	Unshielded	Unshielded	-
4	DC Cable	0.7 + 2.0	Unshielded	Unshielded	-
5	DC Cable	0.7 + 2.0	Unshielded	Unshielded	-
6	DC Cable	0.7 + 2.0	Unshielded	Unshielded	-
7	AC Cable	2.4	Unshielded	Unshielded	-
8	DC Cable	1.2	Unshielded	Unshielded	-
9	AC Cable	1.5	Unshielded	Unshielded	-

**UL Japan, Inc.**

**Shonan EMC Lab.**

1-22-3 Megumigaoka, Hiratsuka-shi, Kanagawa-ken, 259-1220 JAPAN

Telephone : +81 463 50 6400

Facsimile : +81 463 50 6401

## 2. WLAN

PCB B : Chain-0: Dual Monopole Antenna  
: Chain-1: Slot Antenna

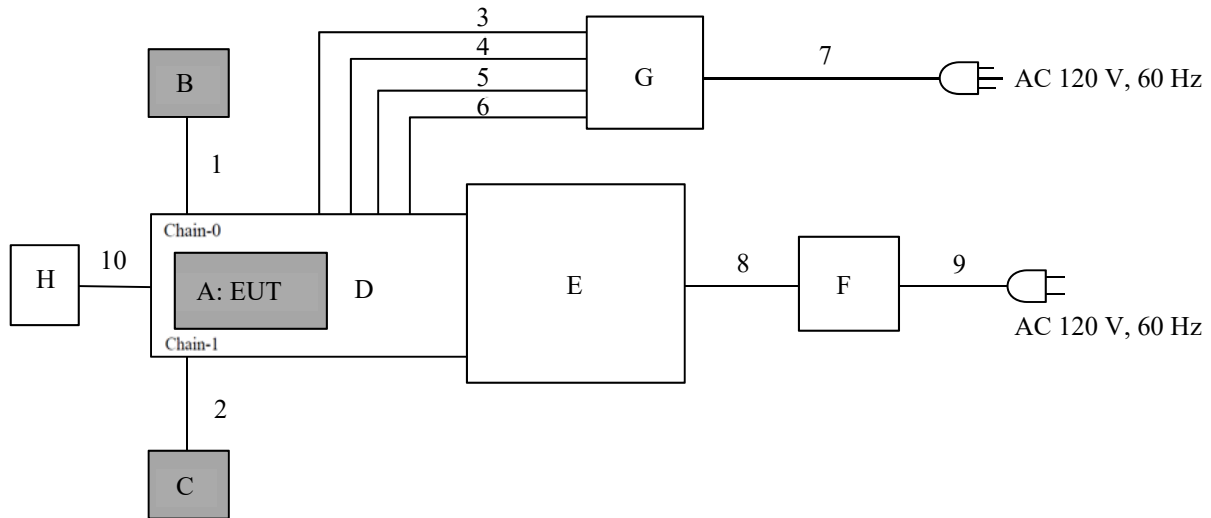

\* Cabling and setup(s) were taken into consideration and test data was taken under worse case conditions.

### Description of EUT and Support equipment

No.	Item	Model number	Serial number	Manufacturer	Remarks
A	Communication Module	Type1VY	B-2	Murata Manufacturing Co., Ltd.	EUT
B	Dual Monopole Antenna	M-d	No.1	SONY	EUT
C	Slot Antenna	S-2.4	No.1	SONY	EUT
D	PCB B	P2ML7925	B-2	Murata Manufacturing Co., Ltd.	-
E	Platform	iMX8	-	NXP Semiconductors	-
F	AC Adapter	EA10682N-120	-	EDACPOWER ELEC.	-
G	Power Supply (DC)	PAN35-10A	DE001677	KIKUSUI	-
H	Terminator	M1459A	89025	Weinschel	-

### List of cables used

No.	Name	Length (m)	Shield		Remarks
			Cable	Connector	
1	Coaxial Cable	0.1	Shielded	Shielded	-
2	Coaxial Cable	0.1	Shielded	Shielded	-
3	DC Cable	0.7 + 2.0	Unshielded	Unshielded	-
4	DC Cable	0.7 + 2.0	Unshielded	Unshielded	-
5	DC Cable	0.7 + 2.0	Unshielded	Unshielded	-
6	DC Cable	0.7 + 2.0	Unshielded	Unshielded	-
7	AC Cable	2.4	Unshielded	Unshielded	-
8	DC Cable	1.2	Unshielded	Unshielded	-
9	AC Cable	1.5	Unshielded	Unshielded	-
10	Coaxial Cable	0.1	Shielded	Shielded	-

**UL Japan, Inc.**

**Shonan EMC Lab.**

1-22-3 Megumigaoka, Hiratsuka-shi, Kanagawa-ken, 259-1220 JAPAN

Telephone : +81 463 50 6400

Facsimile : +81 463 50 6401

### 3. WLAN

PCB B : Chain-0: Dual Monopole Antenna  
: Chain-1: Monopole Antenna

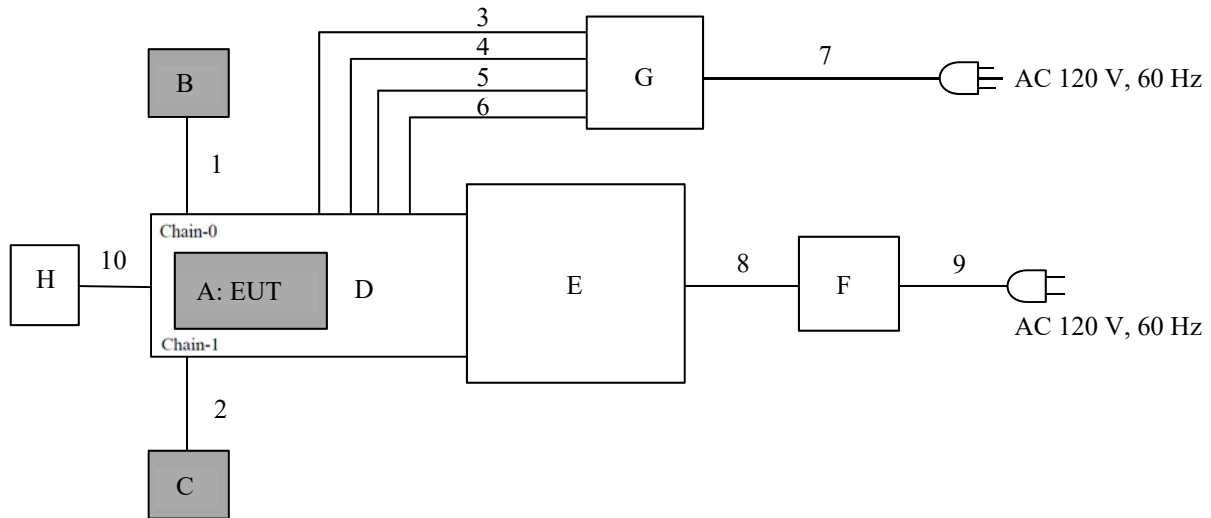

\* Cabling and setup(s) were taken into consideration and test data was taken under worse case conditions.

#### Description of EUT and Support equipment

No.	Item	Model number	Serial number	Manufacturer	Remarks
A	Communication Module	Type1VY	B-2	Murata Manufacturing Co., Ltd.	EUT
B	Dual Monopole Antenna	M-d	No.1	SONY	EUT
C	Monopole Antenna	M-2.4	No.1	SONY	EUT
D	PCB B	P2ML7925	B-2	Murata Manufacturing Co., Ltd.	-
E	Platform	iMX8	-	NXP Semiconductors	-
F	AC Adapter	EA10682N-120	-	EDACPOWER ELEC.	-
G	Power Supply (DC)	PAN35-10A	DE001677	KIKUSUI	-
H	Terminator	M1459A	89025	Weinschel	-

#### List of cables used

No.	Name	Length (m)	Shield		Remarks
			Cable	Connector	
1	Coaxial Cable	0.1	Shielded	Shielded	-
2	Coaxial Cable	0.1	Shielded	Shielded	-
3	DC Cable	0.7 + 2.0	Unshielded	Unshielded	-
4	DC Cable	0.7 + 2.0	Unshielded	Unshielded	-
5	DC Cable	0.7 + 2.0	Unshielded	Unshielded	-
6	DC Cable	0.7 + 2.0	Unshielded	Unshielded	-
7	AC Cable	2.4	Unshielded	Unshielded	-
8	DC Cable	1.2	Unshielded	Unshielded	-
9	AC Cable	1.5	Unshielded	Unshielded	-
10	Coaxial Cable	0.1	Shielded	Shielded	-

**UL Japan, Inc.**

**Shonan EMC Lab.**

1-22-3 Megumigaoka, Hiratsuka-shi, Kanagawa-ken, 259-1220 JAPAN

Telephone : +81 463 50 6400

Facsimile : +81 463 50 6401

4. BT LE

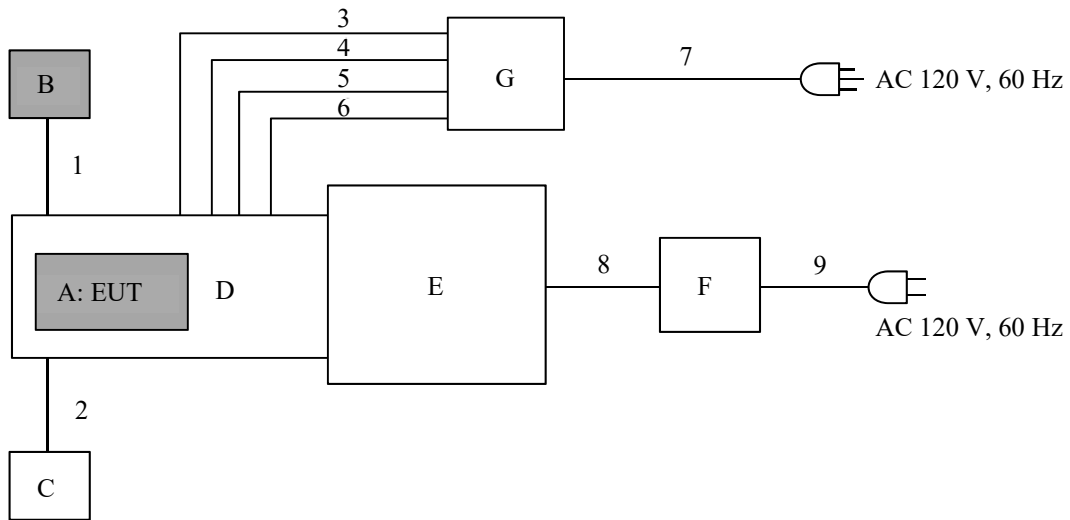

\* Cabling and setup(s) were taken into consideration and test data was taken under worse case conditions.

**Description of EUT and Support equipment**

No.	Item	Model number	Serial number	Manufacturer	Remarks
A	Communication Module	Type1VY	A-9	Murata Manufacturing Co., Ltd.	EUT
B	Dual Monopole Antenna	M-d	No.1	SONY	EUT
C	Terminator	M1459A	89025	Weinschel	-
D	PCB A	P2ML7925	A-9	Murata Manufacturing Co., Ltd.	-
E	Platform	iMX8	-	NXP Semiconductors	-
F	AC Adapter	EA10682N-120	-	EDACPOWER ELEC.	-
G	Power Supply (DC)	PAN35-10A	DE001677	KIKUSUI	-

**List of cables used**

No.	Name	Length (m)	Shield		Remarks
			Cable	Connector	
1	Coaxial Cable	0.1	Shielded	Shielded	-
2	Coaxial Cable	0.1	Shielded	Shielded	-
3	DC Cable	0.7 + 2.0	Unshielded	Unshielded	-
4	DC Cable	0.7 + 2.0	Unshielded	Unshielded	-
5	DC Cable	0.7 + 2.0	Unshielded	Unshielded	-
6	DC Cable	0.7 + 2.0	Unshielded	Unshielded	-
7	AC Cable	2.4	Unshielded	Unshielded	-
8	DC Cable	1.2	Unshielded	Unshielded	-
9	AC Cable	1.5	Unshielded	Unshielded	-



## **SECTION 5: Conducted Emission**

### **Test Procedure and conditions**

EUT was placed on a platform of nominal size, 2.0 m by 1.5 m, raised 0.8 m above the conducting ground plane. The table is made of Styrofoam and covered with polyvinyl chloride. That has very low permittivity. The rear of tabletop was located 40 cm to the vertical conducting plane. The rear of EUT, including peripherals aligned and flushed with rear of tabletop. All other surfaces of tabletop were at least 80 cm from any other grounded conducting surface. EUT was located 80 cm from a Line Impedance Stabilization Network (LISN) / Artificial mains Network (AMN) and excess AC cable was bundled in center.

I/O cables that were connected to the peripherals were bundled in center. They were folded back and forth forming a bundle 30 cm to 40 cm long and were hanged at a 40 cm height to the ground plane.

The AC Mains Terminal Continuous disturbance Voltage has been measured with the EUT via DC power supply in a Shielded room.

The EUT via DC power supply was connected to a LISN (AMN).

An overview sweep with peak detection has been performed.

The test results and limit are rounded off to one decimal place, so some differences might be observed.

**Detector** : QP and CISPR AV  
**Measurement range** : 0.15 MHz - 30 MHz  
**Test data** : APPENDIX  
**Test result** : Pass

**Figure 1: Test Setup**

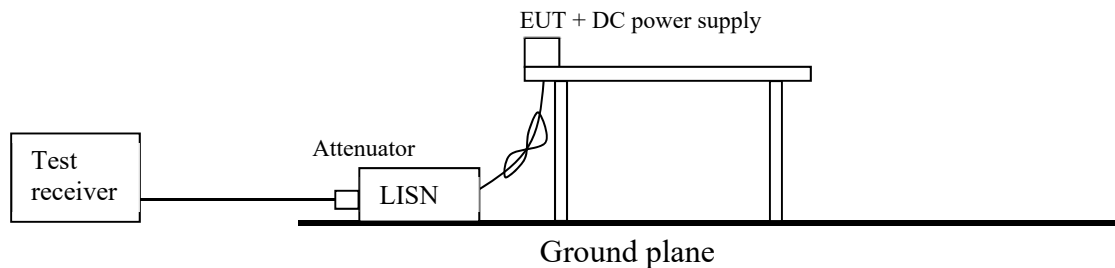

## **SECTION 6: Radiated Spurious Emission**

### **Test Procedure**

It was measured based on "8.5 and 8.6 of KDB 558074 D01 15.247 Meas Guidance v05r02".

[For below 1 GHz]

EUT was placed on a urethane platform of nominal size, 0.5 m by 0.5 m, raised 0.8 m above the conducting ground plane. The Radiated Electric Field Strength has been measured in a Semi Anechoic Chamber with a ground plane.

[For above 1 GHz]

EUT was placed on a urethane platform of nominal size, 0.5 m by 0.5 m, raised 1.5 m above the conducting ground plane. The Radiated Electric Field Strength has been measured in a Semi Anechoic Chamber with absorbent materials lined on a ground plane.

The height of the measuring antenna varied between 1 m and 4 m and EUT was rotated a full revolution in order to obtain the maximum value of the electric field strength.

Test antenna was aimed at the EUT for receiving the maximum signal and always kept within the illumination area of the 3 dB beamwidth of the antenna.

The measurements were performed for both vertical and horizontal antenna polarization with the Test Receiver, or the Spectrum Analyzer.

The measurements were made with the following detector function of the test receiver and the Spectrum analyzer (in linear mode).

The test was made with the detector (RBW/VBW) in the following table.

When using Spectrum analyzer, the test was made with adjusting span to zero by using peak hold.

### **Test Antennas are used as below;**

Frequency	30 MHz to 200 MHz	200 MHz to 1 GHz	Above 1 GHz
Antenna Type	Biconical	Logperiodic	Horn

In any 100 kHz bandwidth outside the restricted band in which the spread spectrum intentional radiator is operating, the radio frequency power that is produced by the intentional radiator confirmed 20 dB below that in the 100 kHz bandwidth within the band that contains the highest level of the desired power, based on a radiated measurement.

### **20 dBc was applied to the frequency over the limit of FCC 15.209 / Table 4 of RSS-Gen 8.9(ISED) and outside the restricted band of FCC15.205 / Table 6 of RSS-Gen 8.10 (ISED).**

Frequency	Below 1 GHz	Above 1 GHz		20 dBc
Instrument used	Test Receiver	Spectrum Analyzer		Spectrum Analyzer
Detector	QP	PK	AV *1)	PK
IF Bandwidth	BW 120 kHz	RBW: 1 MHz VBW: 3 MHz	For WLAN <u>11.12.2.5.3</u> RBW: 1 MHz VBW: 1/T (T: burst length, refer to Burst rate confirmation sheet) Detector: Peak Trace: Max Hold  For BT LE <u>11.12.2.5.2</u> RBW: 1 MHz VBW: 3 MHz Detector: Power Averaging (Linear voltage) Trace: 100 traces Duty factor was added to the results.	RBW: 100 kHz VBW: 300 kHz

\*1) Average Power Measurement was performed based on ANSI C63.10-2013.

**UL Japan, Inc.**

**Shonan EMC Lab.**

1-22-3 Megumigaoka, Hiratsuka-shi, Kanagawa-ken, 259-1220 JAPAN

Telephone : +81 463 50 6400

Facsimile : +81 463 50 6401

**Figure 2: Test Setup**

Below 1 GHz

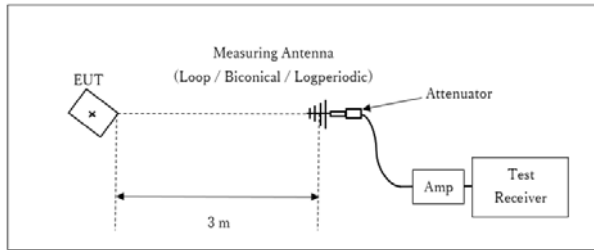

× : Center of turn table

Test Distance: 3 m

1 GHz - 13 GHz

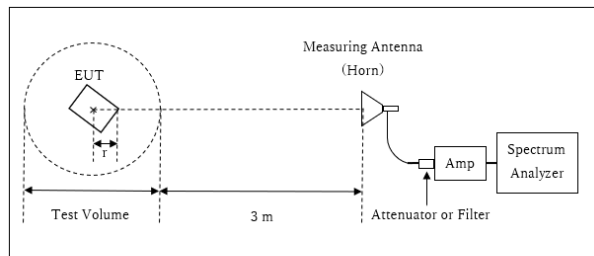

r : Radius of an outer periphery of EUT  
× : Center of turn table

\*1)  
Distance Factor:  $20 \times \log(3.84 \text{ m} / 3.0 \text{ m}) = 2.15 \text{ dB}$   
\* Test Distance:  $(3 + \text{Test Volume} / 2) - r = 3.84 \text{ m}$   
r = 0.16 m

\*2)  
Distance Factor:  $20 \times \log(3.79 \text{ m} / 3.0 \text{ m}) = 2.04 \text{ dB}$   
\* Test Distance:  $(3 + \text{Test Volume} / 2) - r = 3.79 \text{ m}$   
r = 0.21 m

Test Volume : 2.0 m  
(Test Volume has been calibrated based on CISPR 16-1-4.)

13 GHz – 26.5 GHz

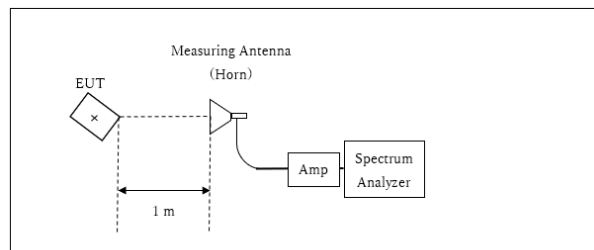

× : Center of turn table

Distance Factor:  $20 \times \log(1.0 \text{ m} / 3.0 \text{ m}) = -9.54 \text{ dB}$   
\*Test Distance: 1 m

\*1) For configuration of section 4.2.1, 4.2.3, and 4.2.4.  
\*2) For configuration of section 4.2.2.

- The carrier level and noise levels were confirmed at each position of X, Y and Z axes of EUT to see the position of maximum noise, and the test was made at the position that has the maximum noise.  
The test results and limit are rounded off to one decimal place, so some differences might be observed.

Worst position:

<Configuration of section 4.2.1>

Module axis

	Carrier	Spurious				
		Below 1 GHz	1 GHz - 2.8 GHz	2.8 GHz - 13 GHz	13 GHz - 18 GHz	18 GHz - 26.5 GHz
Horizontal	X	X	X	X	X	X
Vertical	X	X	X	X	X	X

Antenna axis: Chain-0

	Carrier	Spurious				
		Below 1 GHz	1 GHz - 2.8 GHz	2.8 GHz - 13 GHz	13 GHz - 18 GHz	18 GHz - 26.5 GHz
Horizontal	X	X	X	Z	X	X
Vertical	Z	X	Z	Z	X	X

Antenna axis: Chain-1

	Carrier	Spurious				
		Below 1 GHz	1 GHz - 2.8 GHz	2.8 GHz - 13 GHz	13 GHz - 18 GHz	18 GHz - 26.5 GHz
Horizontal	X	X	X	Z	X	X
Vertical	Z	X	Z	Z	X	X

<Configuration of section 4.2.2>

Module axis

	Carrier	Spurious				
		Below 1 GHz	1 GHz - 2.8 GHz	2.8 GHz - 13 GHz	13 GHz - 18 GHz	18 GHz - 26.5 GHz
Horizontal	X	X	X	X	X	X
Vertical	X	X	X	X	X	X

Antenna axis: Chain-0

	Carrier	Spurious				
		Below 1 GHz	1 GHz - 2.8 GHz	2.8 GHz - 13 GHz	13 GHz - 18 GHz	18 GHz - 26.5 GHz
Horizontal	X	X	X	X	X	X
Vertical	Z	X	Z	Z	X	X

Antenna axis: Chain-1

	Carrier	Spurious				
		Below 1 GHz	1 GHz - 2.8 GHz	2.8 GHz - 13 GHz	13 GHz - 18 GHz	18 GHz - 26.5 GHz
Horizontal	Z	X	Z	Z	X	X
Vertical	Y	X	Y	Y	X	X

<Configuration of section 4.2.3>

Module axis

	Carrier	Spurious				
		Below 1 GHz	1 GHz - 2.8 GHz	2.8 GHz - 13 GHz	13 GHz - 18 GHz	18 GHz - 26.5 GHz
Horizontal	X	X	X	X	X	X
Vertical	X	X	X	X	X	X

Antenna axis: Chain-0

	Carrier	Spurious				
		Below 1 GHz	1 GHz - 2.8 GHz	2.8 GHz - 13 GHz	13 GHz - 18 GHz	18 GHz - 26.5 GHz
Horizontal	X	X	X	X	X	X
Vertical	Z	X	Z	Z	X	X

Antenna axis: Chain-1

	Carrier	Spurious				
		Below 1 GHz	1 GHz - 2.8 GHz	2.8 GHz - 13 GHz	13 GHz - 18 GHz	18 GHz - 26.5 GHz
Horizontal	X	X	X	X	X	X
Vertical	Z	X	Z	X	X	X

<Configuration of section 4.2.4>

Module axis

	Carrier	Spurious				
		Below 1 GHz	1 GHz - 2.8 GHz	2.8 GHz - 13 GHz	13 GHz - 18 GHz	18 GHz - 26.5 GHz
Horizontal	X	X	X	X	X	X
Vertical	X	X	X	X	X	X

Antenna axis

	Carrier	Spurious				
		Below 1 GHz	1 GHz - 2.8 GHz	2.8 GHz - 13 GHz	13 GHz - 18 GHz	18 GHz - 26.5 GHz
Horizontal	X	X	X	X	X	X
Vertical	Z	X	Z	Z	X	X

The test results and limit are rounded off to one decimal place, so some differences might be observed.

Measurement range : 30 MHz - 26.5 GHz  
Test data : APPENDIX  
Test result : Pass

## **SECTION 7: Antenna Terminal Conducted Tests**

### **Test Procedure**

The tests were made with below setting connected to the antenna port.

<b>Test</b>	<b>Span</b>	<b>RBW</b>	<b>VBW</b>	<b>Sweep time</b>	<b>Detector</b>	<b>Trace</b>	<b>Instrument used</b>
6 dB Bandwidth	Enough width to display emission skirts	100 kHz	300 kHz	Auto	Peak	Max Hold	Spectrum Analyzer
99 % Occupied Bandwidth *1)	Enough width to display emission skirts	1 to 5 % of OBW	Three times of RBW	Auto	Peak	Max Hold	Spectrum Analyzer
Maximum Peak Output Power	-	-	-	Auto	Peak/ Average *2)	-	Power Meter (Sensor: 160 MHz BW)
Peak Power Density	1.5 times the 6 dB Bandwidth	3 kHz	9.1 kHz	Auto	Peak	Max Hold	Spectrum Analyzer *3)
Conducted Spurious Emission *4)	9 kHz to 150 kHz	200 Hz	620 Hz	Auto	Peak	Max Hold	Spectrum Analyzer
	150 kHz to 30 MHz	10 kHz	30 kHz				

\*1) Peak hold was applied as Worst-case measurement.

\*2) Reference data

\*3) Section 11.10.2 Method PKPSD (peak PSD) of "ANSI C63.10-2013".

\*4) In the frequency range below 30 MHz, RBW was narrowed to separate the noise contents.

Then, wide-band noise near the limit was checked separately, however the noise was not detected as shown in the chart.

(9 kHz - 150 kHz: RBW = 200 Hz, 150 kHz - 30 MHz: RBW = 10 kHz)

The test results and limit are rounded off to two decimals place, so some differences might be observed.  
The equipment and cables were not used for factor 0 dB of the data sheets.

**Test data** : APPENDIX  
**Test result** : Pass

**APPENDIX 1: Test data**

**Conducted Emission**

EUT Serial No.: A-1  
Antenna Chain-0: Dual Monopole, Chain-1: Dual Monopole

**DATA OF CONDUCTED EMISSION TEST**

UL Japan, Inc. Shonan EMC Lab. No.3 Shielded Room  
Date : 2019/09/20

Mode : Tx, 11g, high power, 2412 MHz  
Power : AC 120 V/60 Hz  
Temp./Humi. : 22 deg.C / 64 %RH

Limit : FCC\_Part 15 Subpart C(15.207)

Engineer : Takahiro Suzuki

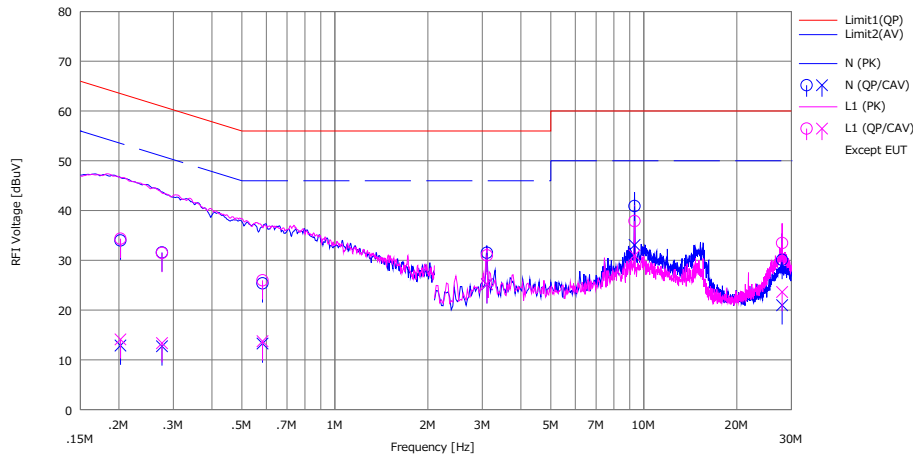

No.	Freq. [MHz]	Reading		C.Fac	Results		Limit		Margin		Phase	Comment
		<QP>	<CAV>		<QP>	<CAV>	<QP>	<AV>	<QP>	<AV>		
		[dBuV]	[dBuV]		[dB]	[dBuV]	[dBuV]	[dBuV]	[dB]	[dB]		
1	0.20227	21.55	0.44	12.44	33.99	12.88	63.52	53.52	29.5	40.6	N	-
2	0.27568	19.15	0.28	12.44	31.59	12.72	60.95	50.95	29.3	38.2	N	
3	0.58319	12.92	0.83	12.46	25.38	13.29	56.00	46.00	30.6	32.7	N	
4	3.10488	18.93	12.59	12.60	31.53	25.19	56.00	46.00	24.4	20.8	N	
5	9.32646	28.00	20.18	12.89	40.89	33.07	60.00	50.00	19.1	16.9	N	
6	28.01976	16.49	7.37	13.61	30.10	20.98	60.00	50.00	29.9	29.0	N	
7	0.20227	21.89	1.68	12.44	34.33	14.12	63.52	53.52	29.1	39.4	L1	
8	0.27568	19.05	0.92	12.44	31.49	13.36	60.95	50.95	29.4	37.5	L1	
9	0.58319	13.54	1.28	12.46	26.00	13.74	56.00	46.00	30.0	32.2	L1	
10	3.10488	18.38	12.65	12.60	30.98	25.25	56.00	46.00	25.0	20.7	L1	
11	9.32646	25.00	18.11	12.89	37.89	31.00	60.00	50.00	22.1	19.0	L1	
12	28.01976	19.87	10.02	13.61	33.48	23.63	60.00	50.00	26.5	26.3	L1	

Calculation: Result[dBuV]=Reading[dBuV]+C.Fac(LISN(AMN)+Cable+ATT)[dB]  
LISN(AMN): SLS-05

## Conducted Emission

EUT Serial No.: B-2  
Antenna : Chain-0: Dual Monopole, Chain-1: Slot

### DATA OF CONDUCTED EMISSION TEST

UL Japan, Inc. Shonan EMC Lab. No.3 Shielded Room  
Date : 2019/09/20

Mode : Tx, 11g, high power, 2412 MHz  
Power : AC 120 V/60 Hz  
Temp./Humi. : 22 deg.C / 64 %RH

Limit : FCC\_Part 15 Subpart C(15.207)

Engineer : Takahiro Suzuki

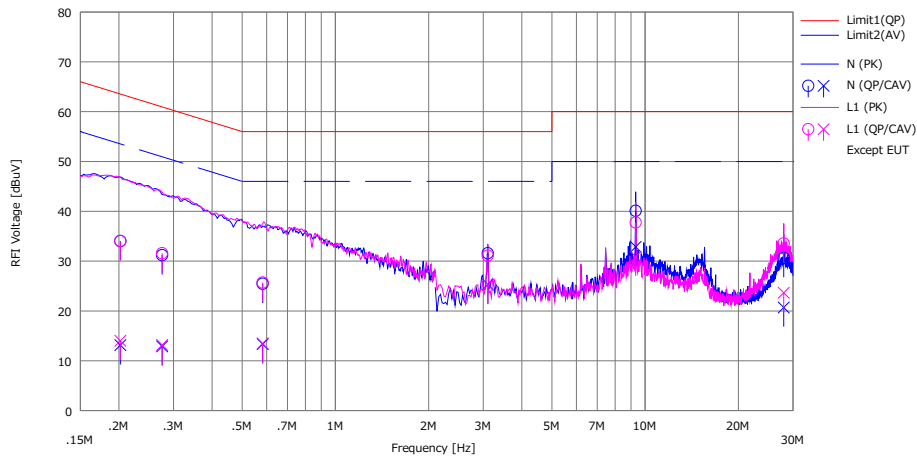

No.	Freq. [MHz]	Reading		C.Fac	Results		Limit		Margin		Phase	Comment
		<QP> [dBuV]	<CAV> [dBuV]		<QP> [dBuV]	<CAV> [dBuV]	<QP> [dBuV]	<AV> [dBuV]	<QP> [dB]	<AV> [dB]		
1	0.20213	21.58	0.69	12.44	34.02	13.13	63.52	53.52	29.5	40.3	N	-
2	0.27586	18.74	0.43	12.44	31.18	12.87	60.94	50.94	29.7	38.0	N	
3	0.58261	12.99	0.87	12.46	25.45	13.33	56.00	46.00	30.5	32.6	N	
4	3.10459	18.99	12.72	12.60	31.59	25.32	56.00	46.00	24.4	20.6	N	
5	9.32614	27.19	19.98	12.89	40.08	32.87	60.00	50.00	19.9	17.1	N	
6	28.01547	17.00	7.09	13.61	30.61	20.70	60.00	50.00	29.3	29.3	N	
7	0.20213	21.57	1.57	12.44	34.01	14.01	63.52	53.52	29.5	39.5	L1	
8	0.27586	19.13	0.72	12.44	31.57	13.16	60.94	50.94	29.3	37.7	L1	
9	0.58261	13.25	1.01	12.46	25.71	13.47	56.00	46.00	30.2	32.5	L1	
10	3.10459	18.50	12.62	12.60	31.10	25.22	56.00	46.00	24.9	20.7	L1	
11	9.32614	24.86	18.00	12.89	37.75	30.89	60.00	50.00	22.2	19.1	L1	
12	28.01547	19.93	10.03	13.61	33.54	23.64	60.00	50.00	26.4	26.3	L1	

Calculation: Result[dBuV]=Reading[dBuV]+C.Fac(LISN(AMN)+Cable+ATT)[dB]  
LISN(AMN): SLS-05

**UL Japan, Inc.**

**Shonan EMC Lab.**

1-22-3 Megumigaoka, Hiratsuka-shi, Kanagawa-ken, 259-1220 JAPAN

Telephone : +81 463 50 6400

Facsimile : +81 463 50 6401



## Conducted Emission

EUT Serial No.: B-2  
Antenna : Chain-0: Dual Monopole, Chain-1: Monopole

### DATA OF CONDUCTED EMISSION TEST

UL Japan, Inc. Shonan EMC Lab. No.3 Shielded Room  
Date : 2019/09/21

Mode : Tx, 11g, high power, 2412 MHz

Power : AC 120 V/60 Hz  
Temp./Humi. : 22 deg.C / 64 %RH

Limit : FCC\_Part 15 Subpart C(15.207)

Engineer : Takahiro Suzuki

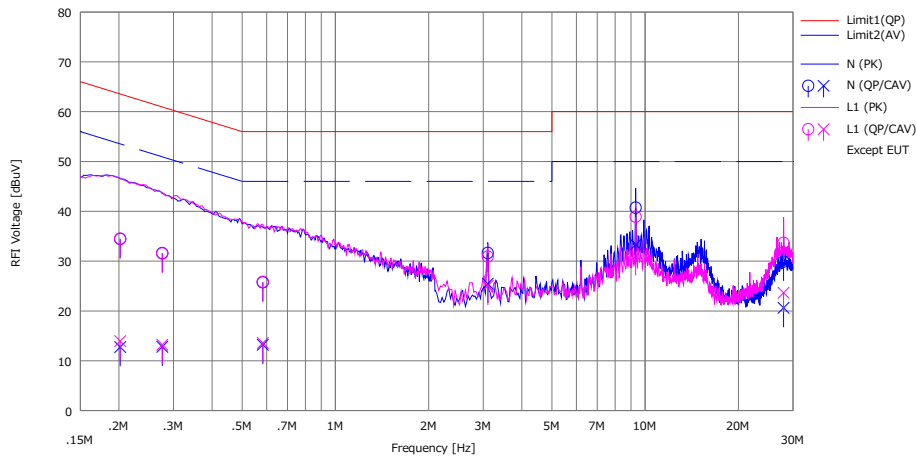

No.	Freq. [MHz]	Reading		C.Fac	Results		Limit		Margin		Phase	Comment
		<QP> [dBuV]	<CAV> [dBuV]		<QP> [dBuV]	<CAV> [dBuV]	<QP> [dBuV]	<AV> [dBuV]	<QP> [dB]	<AV> [dB]		
1	0.20208	21.98	0.32	12.44	34.42	12.76	63.52	53.52	29.1	40.7	N	-
2	0.27606	19.17	0.35	12.44	31.61	12.79	60.93	50.93	29.3	38.1	N	
3	0.58323	13.26	0.75	12.46	25.72	13.21	56.00	46.00	30.2	32.7	N	
4	3.10454	19.02	12.88	12.60	31.62	25.48	56.00	46.00	24.3	20.5	N	
5	9.32647	27.82	20.41	12.89	40.71	33.30	60.00	50.00	19.2	16.7	N	
6	27.99174	16.28	7.00	13.61	29.89	20.61	60.00	50.00	30.1	29.3	N	
7	0.20208	22.07	1.49	12.44	34.51	13.93	63.52	53.52	29.0	39.5	L1	
8	0.27606	19.09	0.76	12.44	31.53	13.20	60.93	50.93	29.4	37.7	L1	
9	0.58323	13.38	1.09	12.46	25.84	13.55	56.00	46.00	30.1	32.4	L1	
10	3.10454	18.29	12.44	12.60	30.89	25.04	56.00	46.00	25.1	20.9	L1	
11	9.32647	26.00	18.14	12.89	38.89	31.03	60.00	50.00	21.1	18.9	L1	
12	27.99174	20.05	10.02	13.61	33.66	23.63	60.00	50.00	26.3	26.3	L1	

Calculation: Result[dBuV]=Reading[dBuV]+C.Fac(LISN(AMN)+Cable+ATT)[dB]  
LISN(AMN): SLS-05

## Conducted Emission

EUT Serial No.: A-9

### DATA OF CONDUCTED EMISSION TEST

UL Japan, Inc. Shonan EMC Lab. No.3 Shielded Room  
Date : 2019/09/20

Mode : Tx, BT LE, 2402 MHz  
Power : AC 120 V/60 Hz  
Temp./Humi. : 24 deg.C / 58 %RH

Limit : FCC\_Part 15 Subpart C(15.207) 3

Engineer : Takahiro Suzuki

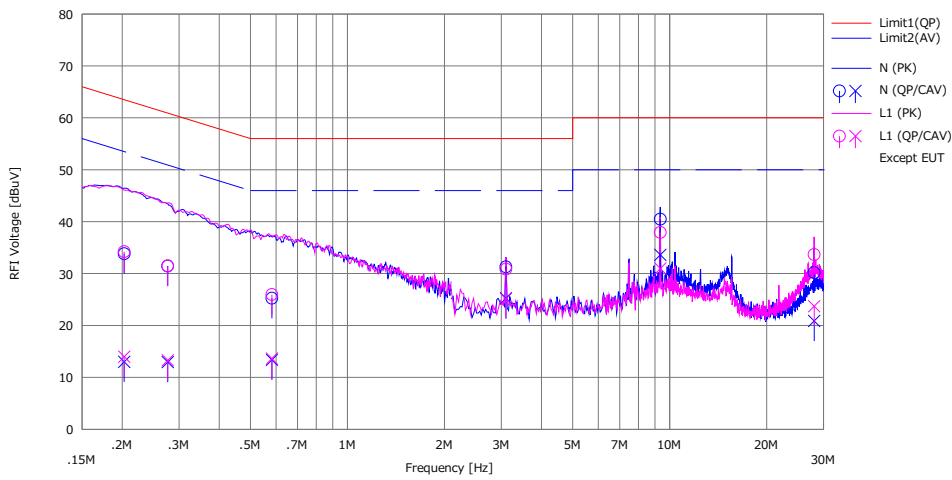

No.	Freq. [MHz]	Reading		C.Fac	Results		Limit		Margin		Phase	Comment
		<QP> [dBuV]	<CAV> [dBuV]		<QP> [dBuV]	<AV> [dBuV]	<QP> [dB]	<AV> [dB]				
1	0.20286	21.37	0.55	12.44	33.81	12.99	63.49	53.49	29.6	40.5	N	-
2	0.27678	19.00	0.51	12.44	31.44	12.95	60.91	50.91	29.4	37.9	N	-
3	0.58302	12.79	0.92	12.46	25.25	13.38	56.00	46.00	30.7	32.6	N	-
4	3.10439	18.67	12.65	12.60	31.27	25.25	56.00	46.00	24.7	20.7	N	-
5	9.35388	27.58	20.72	12.89	40.47	33.61	60.00	50.00	19.5	16.3	N	-
6	28.07583	16.58	7.25	13.61	30.19	20.86	60.00	50.00	29.8	29.1	N	-
7	0.20286	21.78	1.53	12.44	34.22	13.97	63.49	53.49	29.2	39.5	L1	-
8	0.27678	19.03	0.84	12.44	31.47	13.28	60.91	50.91	29.4	37.6	L1	-
9	0.58302	13.50	1.17	12.46	25.96	13.63	56.00	46.00	30.0	32.3	L1	-
10	3.10439	18.24	12.52	12.60	30.84	25.12	56.00	46.00	25.1	20.8	L1	-
11	9.35388	25.03	18.08	12.89	37.92	30.97	60.00	50.00	22.0	19.0	L1	-
12	28.07583	20.04	10.10	13.61	33.65	23.71	60.00	50.00	26.3	26.2	L1	-

Calculation: Result[dBuV]=Reading[dBuV]+C.Fac(LISN(AMN)+Cable+ATT)[dB]  
LISN(AMN): SLS-05

## Conducted Emission

Report No.	13004393S-A-R2
Test place	Shonan EMC Lab. No.3 Shielded Room
Date	September 20, 2019
Temperature / Humidity	24 deg. C / 58 % RH
Engineer	Takahiro Suzuki
Mode	Tx BT LE

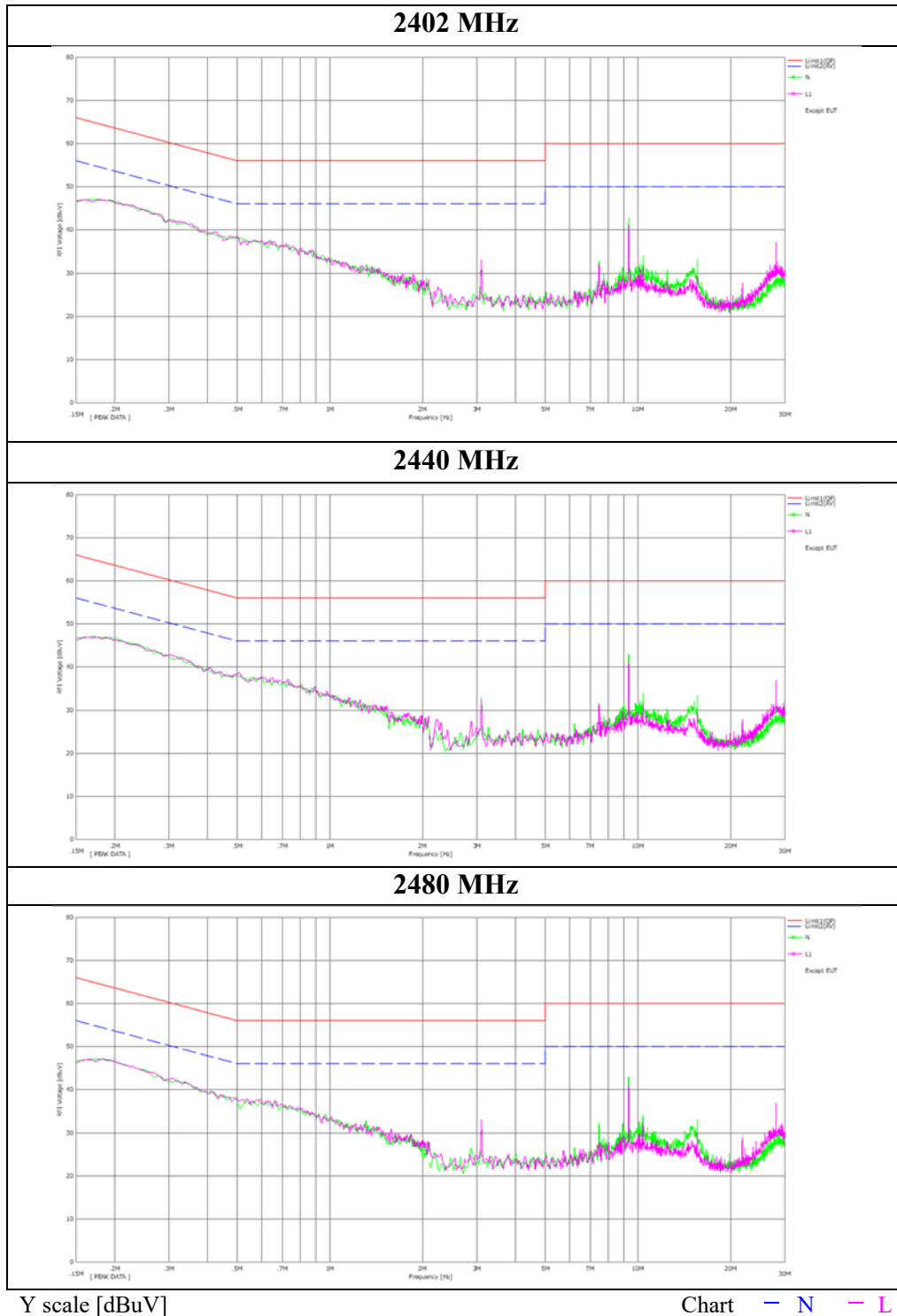

**6 dB Bandwidth and 99 % Occupied Bandwidth**

Report No. 13004393S-A-R2  
Test place Shonan EMC Lab. No.3 Shielded Room  
Date September 10, 2019 September 11, 2019 September 23, 2019  
Temperature / Humidity 25 deg. C / 53 % RH 24 deg. C / 58 % RH 24 deg. C / 42 % RH  
Engineer Takahiro Kawakami Takahiro Kawakami Hiromasa Sato  
Mode Tx, high power

Mode	Frequency [MHz]	99 % Occupied Bandwidth [kHz]	6 dB Bandwidth [MHz]	Limit for 6 dB Bandwidth [MHz]
11b CDD	2412	12932.2	7.870	> 0.5000
	2437	12961.5	7.797	> 0.5000
	2462	12971.0	7.797	> 0.5000
11g CDD	2412	16835.3	16.547	> 0.5000
	2437	16847.4	16.518	> 0.5000
	2462	16842.6	16.506	> 0.5000
11n-20 CDD	2412	18014.3	17.764	> 0.5000
	2437	18014.7	17.723	> 0.5000
	2462	17991.2	17.769	> 0.5000
11n-20 MIMO	2412	18055.4	17.747	> 0.5000
	2437	18028.3	17.758	> 0.5000
	2462	18032.7	17.702	> 0.5000
BT LE	2402	1058.0	0.711	> 0.5000
	2440	1058.0	0.716	> 0.5000
	2480	1062.7	0.716	> 0.5000

**99 % Occupied Bandwidth**

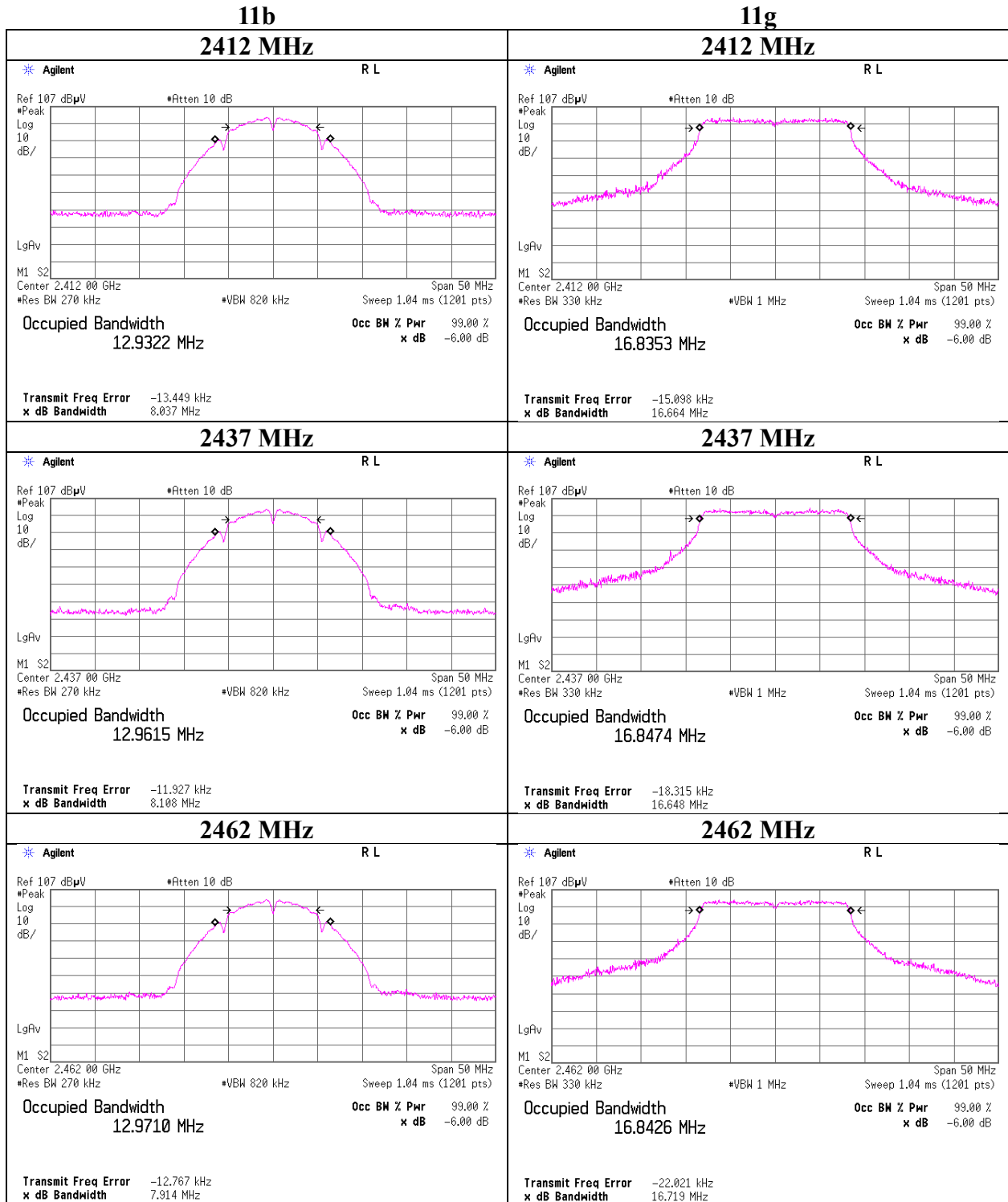

**99 % Occupied Bandwidth**

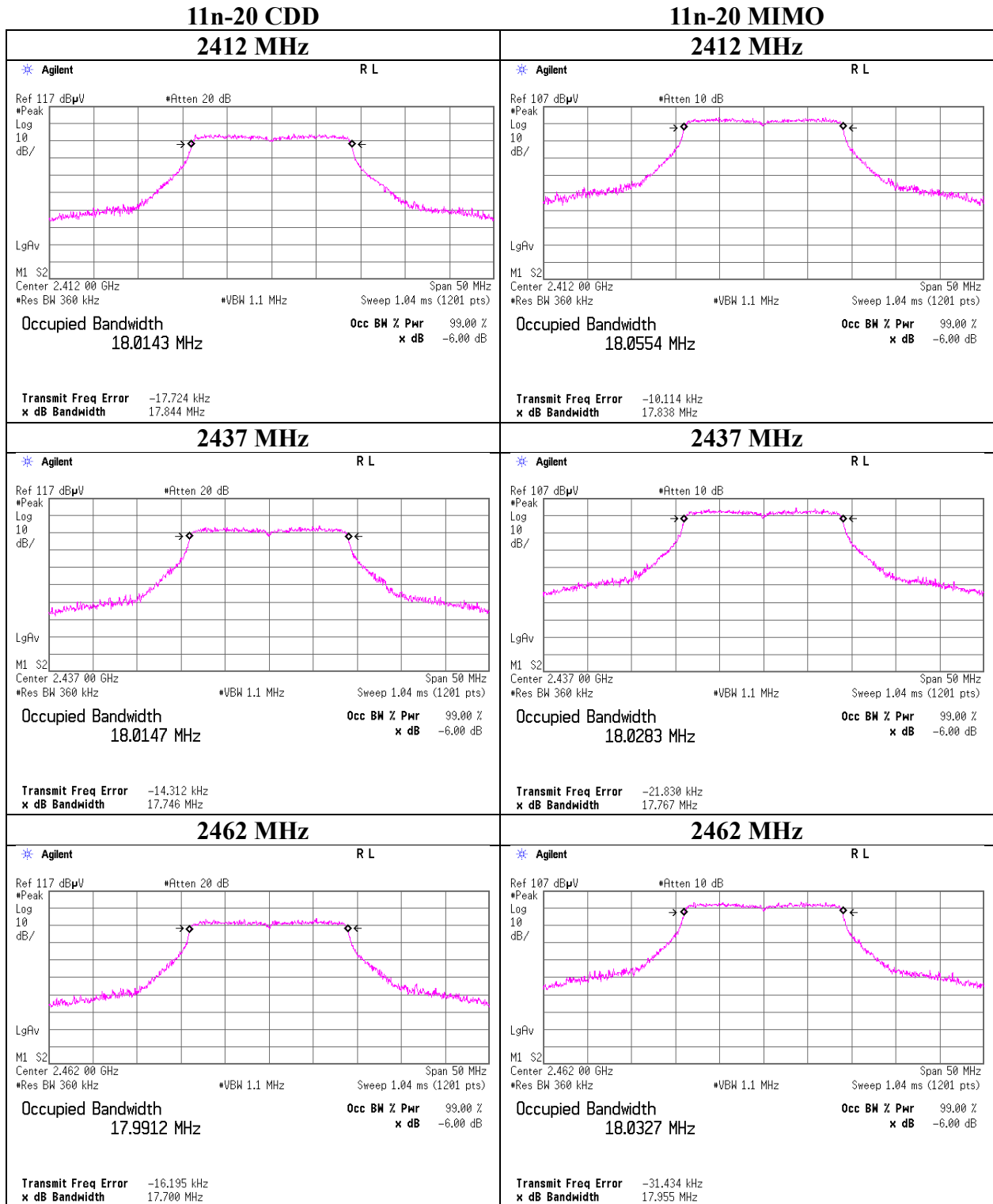

## 99 % Occupied Bandwidth

### BT LE

#### 2402 MHz

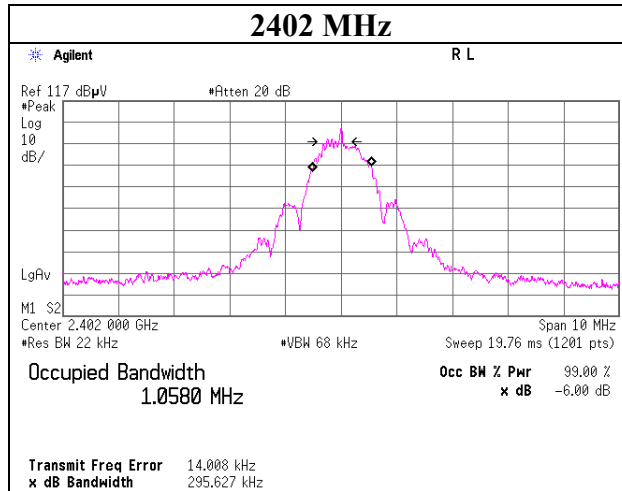

#### 2440 MHz

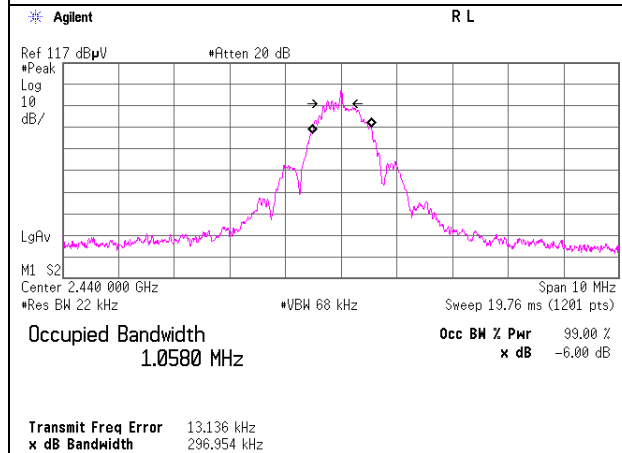

#### 2480 MHz

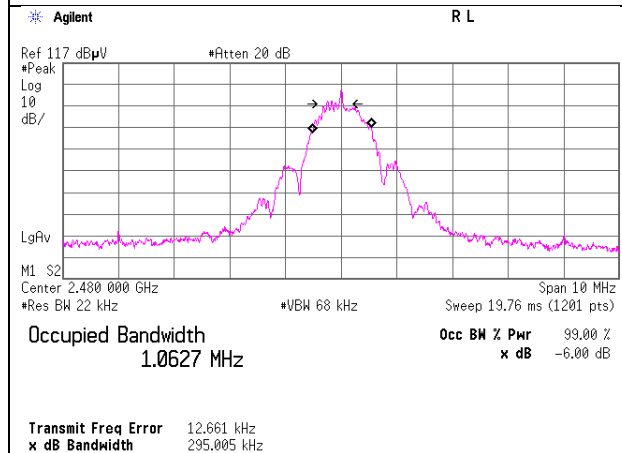

**6 dB Bandwidth**

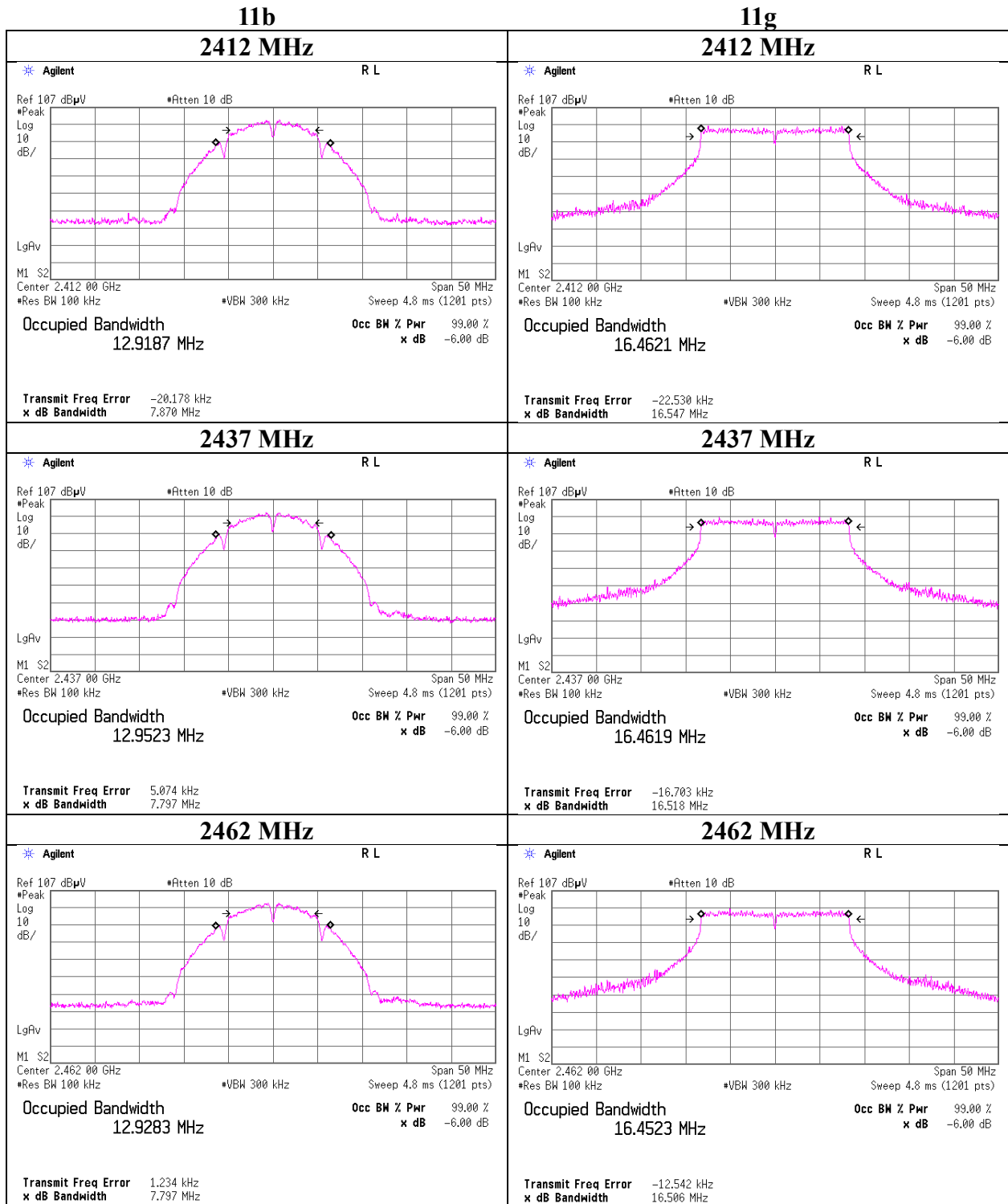



**6 dB Bandwidth**

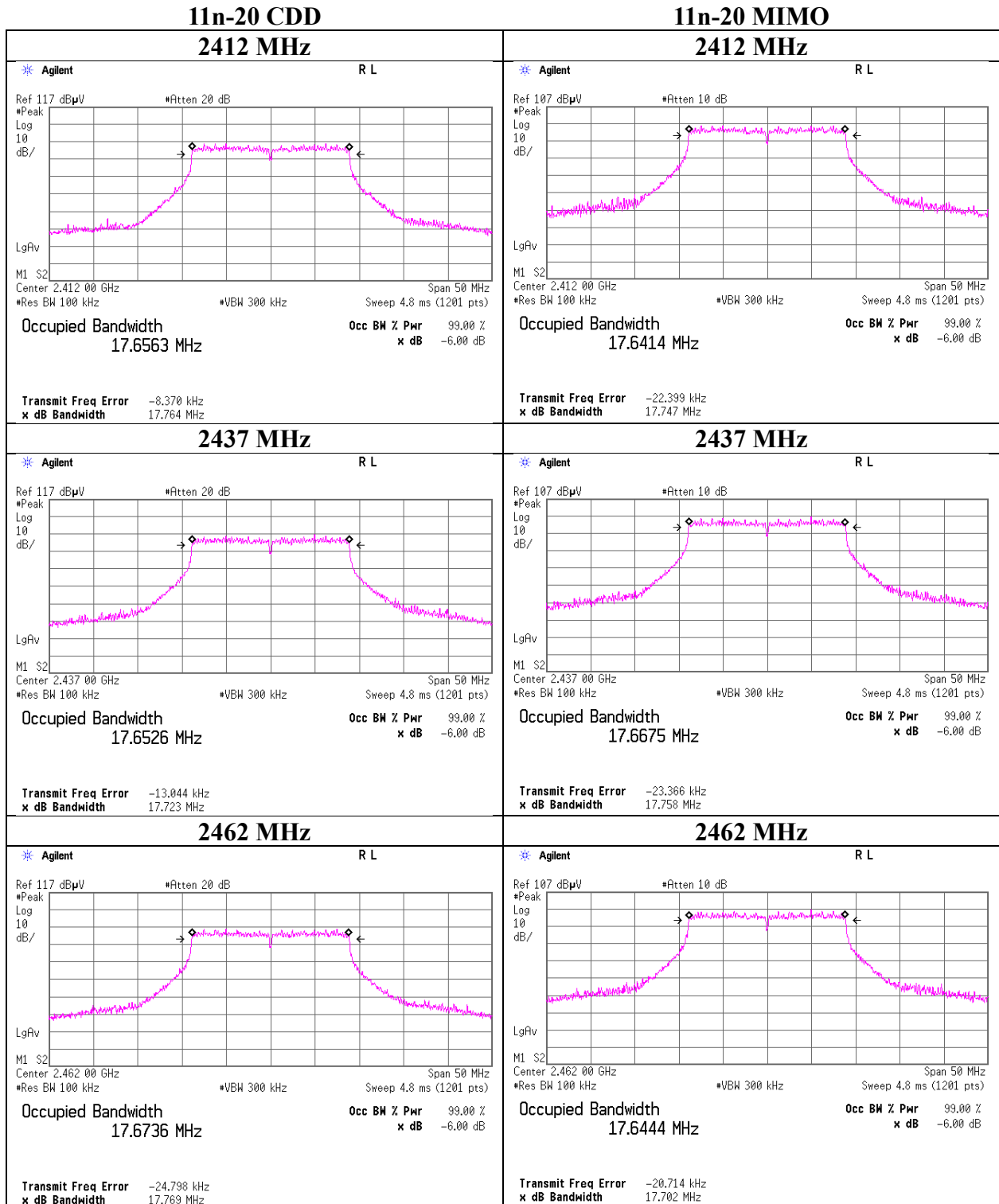

## 6 dB Bandwidth

### BT LE

#### 2402 MHz

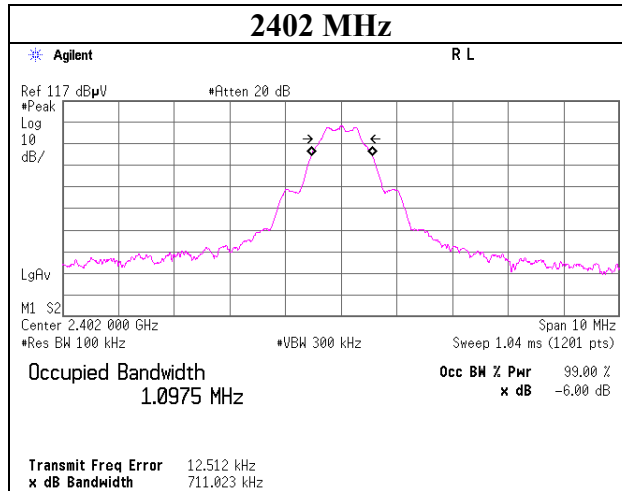

#### 2440 MHz

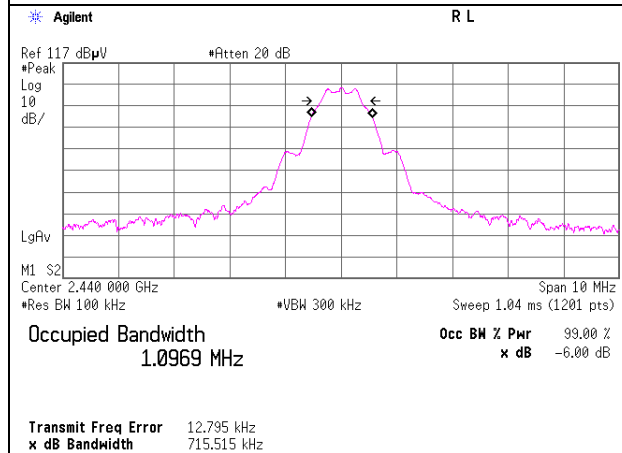

#### 2480 MHz

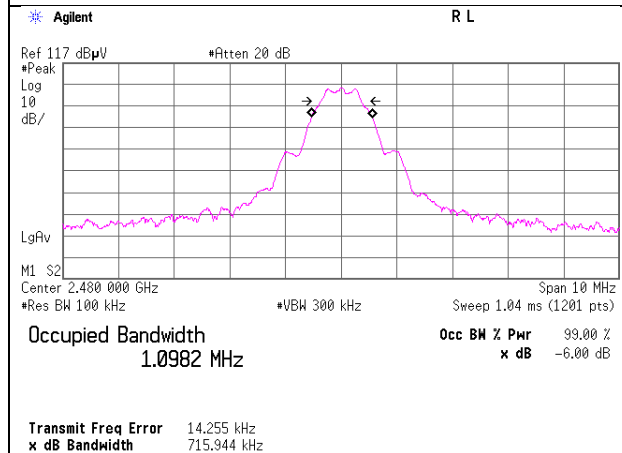

## Maximum Peak Output Power

Report No. 13004393S-A-R2  
Test place Shonan EMC Lab. No.3 Shielded Room  
Date September 4, 2019 September 6, 2019  
Temperature / Humidity 24 deg. C / 49 % RH 24 deg. C / 50 % RH  
Engineer Kenichi Adachi Hiromasa Sato  
Mode Tx, 11b high power

**Serial No. A-1**

Antenna 1 + Antenna 2

Freq. [MHz]	Antenna 1 (Chain 0) Result [mW]	Antenna 2 (Chain 1) Result [mW]	Conducted Power					e.i.r.p.				
			Result		Limit		Margin [dB]	Result		Limit		Margin [dB]
			[dBm]	[mW]	[dBm]	[mW]		[dBm]	[mW]	[dBm]	[mW]	
2412	37.76	43.25	<b>19.09</b>	<b>81.01</b>	30.00	1000	10.91	<b>20.02</b>	<b>100.35</b>	36.02	4000.00	16.01
2437	33.50	38.37	18.57	71.87	30.00	1000	11.43	19.50	89.03	36.02	4000.00	16.53
2462	37.50	41.50	18.98	78.99	30.00	1000	11.02	19.91	97.86	36.02	4000.00	16.11

Sample Calculation:

Result [mW] = Antenna 1 [mW] + Antenna 2 [mW]

e.i.r.p. Result [mW] =  $10^{((\text{Antenna 1 Result [dBm]} + \text{Directional Gain [dBi]}) / 10)} + 10^{((\text{Antenna 2 Result [dBm]} + \text{Directional Gain [dBi]}) / 10)}$

Antenna 1 (Chain 0)

Freq. [MHz]	Reading (Peak) [dBm]	Cable Loss [dB]	Atten. Loss [dB]	Result		Directional Gain [dBi]
				[dBm]	[mW]	
2412	3.68	2.27	9.82	15.77	37.76	0.93
2437	3.13	2.30	9.82	15.25	33.50	0.93
2462	3.61	2.31	9.82	15.74	37.50	0.93

Antenna 2 (Chain 1)

Freq. [MHz]	Reading (Peak) [dBm]	Cable Loss [dB]	Atten. Loss [dB]	Result		Directional Gain [dBi]
				[dBm]	[mW]	
2412	3.78	2.40	10.18	16.36	43.25	0.93
2437	3.26	2.40	10.18	15.84	38.37	0.93
2462	3.59	2.41	10.18	16.18	41.50	0.93

Sample Calculation:

Result = Reading + Cable Loss (including the cable(s) customer supplied) + Attenuator Loss

Directional Gain = G ANT + Array Gain

G ANT = Set equal to the gain of the antenna having the highest gain

Array Gain = 0 dB(i.e.,no array gain) for N ANT < 4

N ANT = number of transmit antennas = 2

**Serial No. B-2**

Antenna 1 + Antenna 2

Freq. [MHz]	Antenna 1 (Chain 0) Result [mW]	Antenna 2 (Chain 1) Result [mW]	Conducted Power					e.i.r.p.				
			Result		Limit		Margin [dB]	Result		Limit		Margin [dB]
			[dBm]	[mW]	[dBm]	[mW]		[dBm]	[mW]	[dBm]	[mW]	
2412	35.97	40.55	<b>18.84</b>	<b>76.53</b>	30.00	1000	11.16	<b>20.82</b>	<b>120.73</b>	36.02	4000.00	15.20
2437	35.89	39.99	18.80	75.89	30.00	1000	11.20	20.78	119.72	36.02	4000.00	15.24
2462	34.36	39.36	18.68	73.71	30.00	1000	11.32	20.66	116.29	36.02	4000.00	15.37

Sample Calculation:

Result [mW] = Antenna 1 [mW] + Antenna 2 [mW]

e.i.r.p. Result [mW] =  $10^{((\text{Antenna 1 Result [dBm]} + \text{Directional Gain [dBi]}) / 10)} + 10^{((\text{Antenna 2 Result [dBm]} + \text{Directional Gain [dBi]}) / 10)}$

Antenna 1 (Chain 0)

Freq. [MHz]	Reading [dBm]	Cable Loss [dB]	Atten. Loss [dB]	Result		Directional Gain [dBi]
				[dBm]	[mW]	
2412	3.47	2.27	9.82	15.56	35.97	1.98
2437	3.43	2.30	9.82	15.55	35.89	1.98
2462	3.23	2.31	9.82	15.36	34.36	1.98

Antenna 2 (Chain 1)

Freq. [MHz]	Reading [dBm]	Cable Loss [dB]	Atten. Loss [dB]	Result		Directional Gain [dBi]
				[dBm]	[mW]	
2412	3.42	2.48	10.18	16.08	40.55	1.98
2437	3.36	2.48	10.18	16.02	39.99	1.98
2462	3.28	2.49	10.18	15.95	39.36	1.98

Sample Calculation:

Result = Reading + Cable Loss (including the cable(s) customer supplied) + Attenuator Loss

Directional Gain = G ANT + Array Gain

G ANT = Set equal to the gain of the antenna having the highest gain

Array Gain = 0 dB(i.e.,no array gain) for N ANT < 4

N ANT = number of transmit antennas = 2

**UL Japan, Inc.**

**Shonan EMC Lab.**

1-22-3 Megumigaoka, Hiratsuka-shi, Kanagawa-ken, 259-1220 JAPAN

Telephone : +81 463 50 6400

Facsimile : +81 463 50 6401

## Maximum Peak Output Power

Report No. 13004393S-A-R2  
Test place Shonan EMC Lab. No.3 Shielded Room  
Date September 5, 2019 September 6, 2019  
Temperature / Humidity 26 deg. C / 49 % RH 24 deg. C / 50 % RH  
Engineer Hiromasa Sato Hiromasa Sato  
Mode Tx, 11g high power

**Serial No. A-1**

**Antenna 1 + Antenna 2**

Freq. [MHz]	Antenna 1 (Chain 0) Result [mW]	Antenna 2 (Chain 1) Result [mW]	Conducted Power					e.i.r.p.				
			Result		Limit		Margin [dB]	Result		Limit		Margin [dB]
			[dBm]	[mW]	[dBm]	[mW]		[dBm]	[mW]	[dBm]	[mW]	
2412	263.63	297.85	<b>27.49</b>	<b>561.48</b>	30.00	1000	2.51	<b>28.42</b>	<b>695.57</b>	36.02	4000.00	7.60
2437	215.77	261.82	26.79	477.59	30.00	1000	3.21	27.72	591.64	36.02	4000.00	8.30
2462	194.98	222.33	26.20	417.32	30.00	1000	3.80	27.13	516.97	36.02	4000.00	8.89

Sample Calculation:

Result [mW] = Antenna 1 [mW] + Antenna 2 [mW]

e.i.r.p. Result [mW] =  $10^{\wedge}((\text{Antenna 1 Result [dBm]} + \text{Directional Gain [dBi]}) / 10) + 10^{\wedge}((\text{Antenna 2 Result [dBm]} + \text{Directional Gain [dBi]}) / 10)$

**Antenna 1 (Chain 0)**

Freq. [MHz]	Reading [dBm]	Cable Loss [dB]	Atten. Loss [dB]	Result		Directional Gain [dBi]
				[dBm]	[mW]	
2412	12.12	2.27	9.82	24.21	263.63	0.93
2437	11.22	2.30	9.82	23.34	215.77	0.93
2462	10.77	2.31	9.82	22.90	194.98	0.93

**Antenna 2 (Chain 1)**

Freq. [MHz]	Reading [dBm]	Cable Loss [dB]	Atten. Loss [dB]	Result		Directional Gain [dBi]
				[dBm]	[mW]	
2412	12.16	2.40	10.18	24.74	297.85	0.93
2437	11.60	2.40	10.18	24.18	261.82	0.93
2462	10.88	2.41	10.18	23.47	222.33	0.93

Sample Calculation:

Result = Reading + Cable Loss (including the cable(s) customer supplied) + Attenuator Loss

Directional Gain = G ANT + Array Gain

G ANT = Set equal to the gain of the antenna having the highest gain

Array Gain = 0 dB(i.e.,no array gain) for N ANT < 4

N ANT = number of transmit antennas = 2

\*Difference between worst rate check data and formal test result is due to the different test condition.

**Serial No. B-2**

**Antenna 1 + Antenna 2**

Freq. [MHz]	Antenna 1 (Chain 0) Result [mW]	Antenna 2 (Chain 1) Result [mW]	Conducted Power					e.i.r.p.				
			Result		Limit		Margin [dB]	Result		Limit		Margin [dB]
			[dBm]	[mW]	[dBm]	[mW]		[dBm]	[mW]	[dBm]	[mW]	
2412	260.62	219.79	<b>26.82</b>	<b>480.40</b>	30.00	1000	3.18	<b>28.80</b>	<b>757.89</b>	36.02	4000.00	7.22
2437	205.12	211.84	26.20	416.95	30.00	1000	3.80	28.18	657.79	36.02	4000.00	7.84
2462	177.42	205.59	25.83	383.01	30.00	1000	4.17	27.81	604.24	36.02	4000.00	8.21

Sample Calculation:

Result [mW] = Antenna 1 [mW] + Antenna 2 [mW]

e.i.r.p. Result [mW] =  $10^{\wedge}((\text{Antenna 1 Result [dBm]} + \text{Directional Gain [dBi]}) / 10) + 10^{\wedge}((\text{Antenna 2 Result [dBm]} + \text{Directional Gain [dBi]}) / 10)$

**Antenna 1 (Chain 0)**

Freq. [MHz]	Reading [dBm]	Cable Loss [dB]	Atten. Loss [dB]	Result		Directional Gain [dBi]
				[dBm]	[mW]	
2412	12.07	2.27	9.82	24.16	260.62	1.98
2437	11.00	2.30	9.82	23.12	205.12	1.98
2462	10.36	2.31	9.82	22.49	177.42	1.98

**Antenna 2 (Chain 1)**

Freq. [MHz]	Reading [dBm]	Cable Loss [dB]	Atten. Loss [dB]	Result		Directional Gain [dBi]
				[dBm]	[mW]	
2412	10.76	2.48	10.18	23.42	219.79	1.98
2437	10.60	2.48	10.18	23.26	211.84	1.98
2462	10.46	2.49	10.18	23.13	205.59	1.98

Sample Calculation:

Result = Reading + Cable Loss (including the cable(s) customer supplied) + Attenuator Loss

Directional Gain = G ANT + Array Gain

G ANT = Set equal to the gain of the antenna having the highest gain

Array Gain = 0 dB(i.e.,no array gain) for N ANT < 4

N ANT = number of transmit antennas = 2

**UL Japan, Inc.**

**Shonan EMC Lab.**

1-22-3 Megumigaoka, Hiratsuka-shi, Kanagawa-ken, 259-1220 JAPAN

Telephone : +81 463 50 6400

Facsimile : +81 463 50 6401

## Maximum Peak Output Power

Report No. 13004393S-A-R2  
Test place Shonan EMC Lab. No.3 Shielded Room  
Date September 3, 2019  
Temperature / Humidity 26 deg. C / 49 % RH  
Engineer Makoto Hosaka  
Mode Tx, 11n-20 CDD high power

**Serial No. A-1**

Antenna 1 + Antenna 2

Freq. [MHz]	Antenna 1 (Chain 0) Result [mW]	Antenna 2 (Chain 1) Result [mW]	Conducted Power					e.i.r.p.				
			Result		Limit		Margin	Result		Limit		Margin
			[dBm]	[mW]	[dBm]	[mW]		[dB]	[dBm]	[mW]	[dBm]	
2412	286.42	201.84	26.89	488.25	30.00	1000	3.11	27.82	604.85	36.02	4000.00	8.20
2437	197.70	281.19	26.80	478.89	30.00	1000	3.20	27.73	593.24	36.02	4000.00	8.29
2462	193.64	345.14	<b>27.31</b>	<b>538.79</b>	30.00	1000	2.69	<b>28.24</b>	<b>667.45</b>	36.02	4000.00	7.78

Sample Calculation:

Result [mW] = Antenna 1 [mW] + Antenna 2 [mW]

e.i.r.p. Result [mW] =  $10^{\wedge}((\text{Antenna 1 Result [dBm]} + \text{Directional Gain [dBi]}) / 10) + 10^{\wedge}((\text{Antenna 2 Result [dBm]} + \text{Directional Gain [dBi]}) / 10)$

Antenna 1 (Chain 0)

Freq. [MHz]	Reading [dBm]	Cable Loss [dB]	Atten. Loss [dB]	Result		Directional Gain [dBi]
				[dBm]	[mW]	
2412	12.48	2.27	9.82	24.57	286.42	0.93
2437	10.84	2.30	9.82	22.96	197.70	0.93
2462	10.74	2.31	9.82	22.87	193.64	0.93

Antenna 2 (Chain 1)

Freq. [MHz]	Reading [dBm]	Cable Loss [dB]	Atten. Loss [dB]	Result		Directional Gain [dBi]
				[dBm]	[mW]	
2412	10.47	2.40	10.18	23.05	201.84	0.93
2437	11.91	2.40	10.18	24.49	281.19	0.93
2462	12.79	2.41	10.18	25.38	345.14	0.93

Sample Calculation:

Result = Reading + Cable Loss (including the cable(s) customer supplied) + Attenuator Loss

Directional Gain = G ANT + Array Gain

G ANT = Set equal to the gain of the antenna having the highest gain

Array Gain = 0 dB(i.e.,no array gain) for N ANT < 4

N ANT = number of transmit antennas = 2

**Serial No. B-2**

Antenna 1 + Antenna 2

Freq. [MHz]	Antenna 1 (Chain 0) Result [mW]	Antenna 2 (Chain 1) Result [mW]	Conducted Power					e.i.r.p.				
			Result		Limit		Margin	Result		Limit		Margin
			[dBm]	[mW]	[dBm]	[mW]		[dB]	[dBm]	[mW]	[dBm]	
2412	314.05	229.09	<b>27.35</b>	<b>543.14</b>	30.00	1000	2.65	<b>29.33</b>	<b>856.86</b>	36.02	4000.00	6.69
2437	274.16	225.42	26.99	499.58	30.00	1000	3.01	28.97	788.15	36.02	4000.00	7.05
2462	168.27	217.77	25.87	386.04	30.00	1000	4.13	27.85	609.02	36.02	4000.00	8.17

Sample Calculation:

Result [mW] = Antenna 1 [mW] + Antenna 2 [mW]

e.i.r.p. Result [mW] =  $10^{\wedge}((\text{Antenna 1 Result [dBm]} + \text{Directional Gain [dBi]}) / 10) + 10^{\wedge}((\text{Antenna 2 Result [dBm]} + \text{Directional Gain [dBi]}) / 10)$

Antenna 1 (Chain 0)

Freq. [MHz]	Reading [dBm]	Cable Loss [dB]	Atten. Loss [dB]	Result		Directional Gain [dBi]
				[dBm]	[mW]	
2412	12.88	2.27	9.82	24.97	314.05	1.98
2437	12.26	2.30	9.82	24.38	274.16	1.98
2462	10.13	2.31	9.82	22.26	168.27	1.98

Antenna 2 (Chain 1)

Freq. [MHz]	Reading [dBm]	Cable Loss [dB]	Atten. Loss [dB]	Result		Directional Gain [dBi]
				[dBm]	[mW]	
2412	10.94	2.48	10.18	23.60	229.09	1.98
2437	10.87	2.48	10.18	23.53	225.42	1.98
2462	10.71	2.49	10.18	23.38	217.77	1.98

Sample Calculation:

Result = Reading + Cable Loss (including the cable(s) customer supplied) + Attenuator Loss

Directional Gain = G ANT + Array Gain

G ANT = Set equal to the gain of the antenna having the highest gain

Array Gain = 0 dB(i.e.,no array gain) for N ANT < 4

N ANT = number of transmit antennas = 2

**UL Japan, Inc.**

**Shonan EMC Lab.**

1-22-3 Megumigaoka, Hiratsuka-shi, Kanagawa-ken, 259-1220 JAPAN

Telephone : +81 463 50 6400

Facsimile : +81 463 50 6401

## Maximum Peak Output Power

Report No. 13004393S-A-R2  
Test place Shonan EMC Lab. No.3 Shielded Room  
Date September 3, 2019  
Temperature / Humidity 26 deg. C / 49 % RH  
Engineer Makoto Hosaka  
Mode Tx, 11n-20 MIMO high power

Serial No. : A-1

Antenna 1 + Antenna 2			Conducted Power					e.i.r.p.				
Freq. [MHz]	Antenna 1 (Chain 0) Result [mW]	Antenna 2 (Chain 1) Result [mW]	Result		Limit		Margin [dB]	Result		Limit		Margin [dB]
			[dBm]	[mW]	[dBm]	[mW]		[dBm]	[mW]	[dBm]	[mW]	
2412	238.78	320.63	27.48	559.41	30.00	1000	2.52	28.41	692.99	36.02	4000.00	7.61
2437	299.92	254.10	27.44	554.01	30.00	1000	2.56	28.37	686.31	36.02	4000.00	7.66
2462	202.30	211.35	26.17	413.65	30.00	1000	3.83	27.10	512.43	36.02	4000.00	8.92

Sample Calculation:

Result [mW] = Antenna 1 [mW] + Antenna 2 [mW]

e.i.r.p. Result [mW] =  $10^{((\text{Antenna 1 Result [dBm]} + \text{Antenna1 Gain [dBi]} ) / 10)} + 10^{((\text{Antenna 2 Result [dBm]} + \text{Antenna2 Gain [dBi]} ) / 10)}$

Antenna 1 (Chain 0)

Freq. [MHz]	Reading [dBm]	Cable Loss [dB]	Atten. Loss [dB]	Result		Antenna 1 Gain [dBi]
				[dBm]	[mW]	
2412	11.69	2.27	9.82	23.78	238.78	0.93
2437	12.65	2.30	9.82	24.77	299.92	0.93
2462	10.93	2.31	9.82	23.06	202.30	0.93

Antenna 2 (Chain 1)

Freq. [MHz]	Reading [dBm]	Cable Loss [dB]	Atten. Loss [dB]	Result		Antenna 2 Gain [dBi]
				[dBm]	[mW]	
2412	12.48	2.40	10.18	25.06	320.63	0.93
2437	11.47	2.40	10.18	24.05	254.10	0.93
2462	10.66	2.41	10.18	23.25	211.35	0.93

Sample Calculation:

Result = Reading + Cable Loss (including the cable(s) customer supplied) + Attenuator Loss

Serial No. B-2

Antenna 1 + Antenna 2			Conducted Power					e.i.r.p.				
Freq. [MHz]	Antenna 1 (Chain 0) Result [mW]	Antenna 2 (Chain 1) Result [mW]	Result		Limit		Margin [dB]	Result		Limit		Margin [dB]
			[dBm]	[mW]	[dBm]	[mW]		[dBm]	[mW]	[dBm]	[mW]	
2412	281.84	224.39	27.04	506.23	30.00	1000	2.96	28.47	703.14	36.02	4000.00	7.55
2437	269.77	213.30	26.84	483.08	30.00	1000	3.16	28.27	670.71	36.02	4000.00	7.76
2462	270.40	214.78	26.86	485.18	30.00	1000	3.14	28.29	673.81	36.02	4000.00	7.74

Sample Calculation:

Result [mW] = Antenna 1 [mW] + Antenna 2 [mW]

e.i.r.p. Result [mW] =  $10^{((\text{Antenna 1 Result [dBm]} + \text{Antenna1 Gain [dBi]} ) / 10)} + 10^{((\text{Antenna 2 Result [dBm]} + \text{Antenna2 Gain [dBi]} ) / 10)}$

Antenna 1 (Chain 0)

Freq. [MHz]	Reading [dBm]	Cable Loss [dB]	Atten. Loss [dB]	Result		Antenna 1 Gain [dBi]
				[dBm]	[mW]	
2412	12.41	2.27	9.82	24.50	281.84	0.93
2437	12.19	2.30	9.82	24.31	269.77	0.93
2462	12.19	2.31	9.82	24.32	270.40	0.93

Antenna 2 (Chain 1)

Freq. [MHz]	Reading [dBm]	Cable Loss [dB]	Atten. Loss [dB]	Result		Antenna 2 Gain [dBi]
				[dBm]	[mW]	
2412	10.85	2.48	10.18	23.51	224.39	1.98
2437	10.63	2.48	10.18	23.29	213.30	1.98
2462	10.65	2.49	10.18	23.32	214.78	1.98

Sample Calculation:

Result = Reading + Cable Loss (including the cable(s) customer supplied) + Attenuator Loss

**UL Japan, Inc.**

**Shonan EMC Lab.**

1-22-3 Megumigaoka, Hiratsuka-shi, Kanagawa-ken, 259-1220 JAPAN

Telephone : +81 463 50 6400

Facsimile : +81 463 50 6401

## Maximum Peak Output Power

Report No. 13004393S-A-R2  
Test place Shonan EMC Lab. No.3 Shielded Room  
Date September 23, 2019  
Temperature / Humidity 24 deg. C / 42 % RH  
Engineer Hiromasa Sato  
Mode Tx, 11b low power

**Serial No. A-1**

**Antenna 1 + Antenna 2**

Freq. [MHz]	Antenna 1 (Chain 0) Result [mW]	Antenna 2 (Chain 1) Result [mW]	Conducted Power					e.i.r.p.				
			Result		Limit		Margin [dB]	Result		Limit		Margin [dB]
			[dBm]	[mW]	[dBm]	[mW]		[dBm]	[mW]	[dBm]	[mW]	
2412	15.42	15.49	14.90	30.91	30.00	1000	15.10	15.83	38.29	36.02	4000.00	20.19
2437	15.78	16.98	<b>15.15</b>	<b>32.76</b>	30.00	1000	14.85	<b>16.08</b>	<b>40.58</b>	36.02	4000.00	19.94
2462	15.03	16.11	14.93	31.14	30.00	1000	15.07	15.86	38.57	36.02	4000.00	20.16

Sample Calculation:

Result [mW] = Antenna 1 [mW] + Antenna 2 [mW]

e.i.r.p. Result [mW] =  $10^{((\text{Antenna 1 Result [dBm]} + \text{Directional Gain [dBi]}) / 10)} + 10^{((\text{Antenna 2 Result [dBm]} + \text{Directional Gain [dBi]}) / 10)}$

**Antenna 1 (Chain 0)**

Freq. [MHz]	Reading (Peak) [dBm]	Cable Loss [dB]	Atten. Loss [dB]	Result		Directional Gain [dBi]
				[dBm]	[mW]	
2412	-0.21	2.27	9.82	11.88	15.42	0.93
2437	-0.14	2.30	9.82	11.98	15.78	0.93
2462	-0.36	2.31	9.82	11.77	15.03	0.93

**Antenna 2 (Chain 1)**

Freq. [MHz]	Reading (Peak) [dBm]	Cable Loss [dB]	Atten. Loss [dB]	Result		Directional Gain [dBi]
				[dBm]	[mW]	
2412	-0.68	2.40	10.18	11.90	15.49	0.93
2437	-0.28	2.40	10.18	12.30	16.98	0.93
2462	-0.52	2.41	10.18	12.07	16.11	0.93

Sample Calculation:

Result = Reading + Cable Loss (including the cable(s) customer supplied) + Attenuator Loss

Directional Gain = G ANT + Array Gain

G ANT = Set equal to the gain of the antenna having the highest gain

Array Gain = 0 dB(i.e.,no array gain) for N ANT < 4

N ANT = number of transmit antennas = 2

**Serial No. B-2**

**Antenna 1 + Antenna 2**

Freq. [MHz]	Antenna 1 (Chain 0) Result [mW]	Antenna 2 (Chain 1) Result [mW]	Conducted Power					e.i.r.p.				
			Result		Limit		Margin [dB]	Result		Limit		Margin [dB]
			[dBm]	[mW]	[dBm]	[mW]		[dBm]	[mW]	[dBm]	[mW]	
2412	16.83	16.83	<b>15.27</b>	<b>33.65</b>	30.00	1000	14.73	<b>17.25</b>	<b>53.09</b>	36.02	4000.00	18.77
2437	14.72	16.71	14.97	31.43	30.00	1000	15.03	16.95	49.59	36.02	4000.00	19.07
2462	13.80	16.75	14.85	30.55	30.00	1000	15.15	16.83	48.20	36.02	4000.00	19.19

Sample Calculation:

Result [mW] = Antenna 1 [mW] + Antenna 2 [mW]

e.i.r.p. Result [mW] =  $10^{((\text{Antenna 1 Result [dBm]} + \text{Directional Gain [dBi]}) / 10)} + 10^{((\text{Antenna 2 Result [dBm]} + \text{Directional Gain [dBi]}) / 10)}$

**Antenna 1 (Chain 0)**

Freq. [MHz]	Reading [dBm]	Cable Loss [dB]	Atten. Loss [dB]	Result		Directional Gain [dBi]
				[dBm]	[mW]	
2412	0.17	2.27	9.82	12.26	16.83	1.98
2437	-0.44	2.30	9.82	11.68	14.72	1.98
2462	-0.73	2.31	9.82	11.40	13.80	1.98

**Antenna 2 (Chain 1)**

Freq. [MHz]	Reading [dBm]	Cable Loss [dB]	Atten. Loss [dB]	Result		Directional Gain [dBi]
				[dBm]	[mW]	
2412	-0.40	2.48	10.18	12.26	16.83	1.98
2437	-0.43	2.48	10.18	12.23	16.71	1.98
2462	-0.43	2.49	10.18	12.24	16.75	1.98

Sample Calculation:

Result = Reading + Cable Loss (including the cable(s) customer supplied) + Attenuator Loss

Directional Gain = G ANT + Array Gain

G ANT = Set equal to the gain of the antenna having the highest gain

Array Gain = 0 dB(i.e.,no array gain) for N ANT < 4

N ANT = number of transmit antennas = 2

**UL Japan, Inc.**

**Shonan EMC Lab.**

1-22-3 Megumigaoka, Hiratsuka-shi, Kanagawa-ken, 259-1220 JAPAN

Telephone : +81 463 50 6400

Facsimile : +81 463 50 6401

## Maximum Peak Output Power

Report No. 13004393S-A-R2  
Test place Shonan EMC Lab. No.3 Shielded Room  
Date September 23, 2019  
Temperature / Humidity 24 deg. C / 42 % RH  
Engineer Hiromasa Sato  
Mode Tx, 11g low power

**Serial No. A-1**

**Antenna 1 + Antenna 2**

Freq. [MHz]	Antenna 1 (Chain 0) Result [mW]	Antenna 2 (Chain 1) Result [mW]	Conducted Power					e.i.r.p.				
			Result		Limit		Margin [dB]	Result		Limit		Margin [dB]
			[dBm]	[mW]	[dBm]	[mW]		[dBm]	[mW]	[dBm]	[mW]	
2412	97.95	99.31	22.95	197.26	30.00	1000	7.05	23.88	244.37	36.02	4000.00	12.14
2437	90.36	111.94	<b>23.06</b>	<b>202.31</b>	30.00	1000	6.94	<b>23.99</b>	<b>250.62</b>	36.02	4000.00	12.03
2462	87.70	111.17	22.99	198.87	30.00	1000	7.01	23.92	246.36	36.02	4000.00	12.10

Sample Calculation:

Result [mW] = Antenna 1 [mW] + Antenna 2 [mW]

e.i.r.p. Result [mW] =  $10^{\wedge}((\text{Antenna 1 Result [dBm]} + \text{Directional Gain [dBi]}) / 10) + 10^{\wedge}((\text{Antenna 2 Result [dBm]} + \text{Directional Gain [dBi]}) / 10)$

**Antenna 1 (Chain 0)**

Freq. [MHz]	Reading [dBm]	Cable Loss [dB]	Atten. Loss [dB]	Result		Directional Gain [dBi]
				[dBm]	[mW]	
2412	7.82	2.27	9.82	19.91	97.95	0.93
2437	7.44	2.30	9.82	19.56	90.36	0.93
2462	7.30	2.31	9.82	19.43	87.70	0.93

**Antenna 2 (Chain 1)**

Freq. [MHz]	Reading [dBm]	Cable Loss [dB]	Atten. Loss [dB]	Result		Directional Gain [dBi]
				[dBm]	[mW]	
2412	7.39	2.40	10.18	19.97	99.31	0.93
2437	7.91	2.40	10.18	20.49	111.94	0.93
2462	7.87	2.41	10.18	20.46	111.17	0.93

Sample Calculation:

Result = Reading + Cable Loss (including the cable(s) customer supplied) + Attenuator Loss

Directional Gain = G ANT + Array Gain

G ANT = Set equal to the gain of the antenna having the highest gain

Array Gain = 0 dB(i.e.,no array gain) for N ANT < 4

N ANT = number of transmit antennas = 2

\*Difference between worst rate check data and formal test result is due to the different test condition.

**Serial No. B-2**

**Antenna 1 + Antenna 2**

Freq. [MHz]	Antenna 1 (Chain 0) Result [mW]	Antenna 2 (Chain 1) Result [mW]	Conducted Power					e.i.r.p.				
			Result		Limit		Margin [dB]	Result		Limit		Margin [dB]
			[dBm]	[mW]	[dBm]	[mW]		[dBm]	[mW]	[dBm]	[mW]	
2412	104.47	97.50	23.05	201.97	30.00	1000	6.95	25.03	318.63	36.02	4000.00	10.99
2437	89.33	114.02	<b>23.08</b>	<b>203.36</b>	30.00	1000	6.92	<b>25.06</b>	<b>320.82</b>	36.02	4000.00	10.96
2462	78.70	102.33	22.58	181.03	30.00	1000	7.42	24.56	285.60	36.02	4000.00	11.46

Sample Calculation:

Result [mW] = Antenna 1 [mW] + Antenna 2 [mW]

e.i.r.p. Result [mW] =  $10^{\wedge}((\text{Antenna 1 Result [dBm]} + \text{Directional Gain [dBi]}) / 10) + 10^{\wedge}((\text{Antenna 2 Result [dBm]} + \text{Directional Gain [dBi]}) / 10)$

**Antenna 1 (Chain 0)**

Freq. [MHz]	Reading [dBm]	Cable Loss [dB]	Atten. Loss [dB]	Result		Directional Gain [dBi]
				[dBm]	[mW]	
2412	8.10	2.27	9.82	20.19	104.47	1.98
2437	7.39	2.30	9.82	19.51	89.33	1.98
2462	6.83	2.31	9.82	18.96	78.70	1.98

**Antenna 2 (Chain 1)**

Freq. [MHz]	Reading [dBm]	Cable Loss [dB]	Atten. Loss [dB]	Result		Directional Gain [dBi]
				[dBm]	[mW]	
2412	7.23	2.48	10.18	19.89	97.50	1.98
2437	7.91	2.48	10.18	20.57	114.02	1.98
2462	7.43	2.49	10.18	20.10	102.33	1.98

Sample Calculation:

Result = Reading + Cable Loss (including the cable(s) customer supplied) + Attenuator Loss

Directional Gain = G ANT + Array Gain

G ANT = Set equal to the gain of the antenna having the highest gain

Array Gain = 0 dB(i.e.,no array gain) for N ANT < 4

N ANT = number of transmit antennas = 2

**UL Japan, Inc.**

**Shonan EMC Lab.**

1-22-3 Megumigaoka, Hiratsuka-shi, Kanagawa-ken, 259-1220 JAPAN

Telephone : +81 463 50 6400

Facsimile : +81 463 50 6401



## Maximum Peak Output Power

Report No. 13004393S-A-R2  
Test place Shonan EMC Lab. No.3 Shielded Room  
Date September 23, 2019  
Temperature / Humidity 24 deg. C / 42 % RH  
Engineer Hiromasa Sato  
Mode Tx, 11n-20 CDD low power

**Serial No. A-1**

**Antenna 1 + Antenna 2**

Freq. [MHz]	Antenna 1 (Chain 0) Result [mW]	Antenna 2 (Chain 1) Result [mW]	Conducted Power					e.i.r.p.				
			Result		Limit		Margin [dB]	Result		Limit		Margin [dB]
			[dBm]	[mW]	[dBm]	[mW]		[dBm]	[mW]	[dBm]	[mW]	
2412	91.20	95.28	22.71	186.48	30.00	1000	7.29	23.64	231.01	36.02	4000.00	12.38
2437	93.33	124.17	<b>23.37</b>	<b>217.49</b>	30.00	1000	6.63	<b>24.30</b>	<b>269.43</b>	36.02	4000.00	11.72
2462	90.99	108.64	23.00	199.63	30.00	1000	7.00	23.93	247.31	36.02	4000.00	12.09

Sample Calculation:

Result [mW] = Antenna 1 [mW] + Antenna 2 [mW]

e.i.r.p. Result [mW] =  $10^{\wedge}((\text{Antenna 1 Result [dBm]} + \text{Directional Gain [dBi]})/10) + 10^{\wedge}((\text{Antenna 2 Result [dBm]} + \text{Directional Gain [dBi]})/10)$

**Antenna 1 (Chain 0)**

Freq. [MHz]	Reading [dBm]	Cable Loss [dB]	Atten. Loss [dB]	Result		Directional Gain [dBi]
				[dBm]	[mW]	
2412	7.51	2.27	9.82	19.60	91.20	0.93
2437	7.58	2.30	9.82	19.70	93.33	0.93
2462	7.46	2.31	9.82	19.59	90.99	0.93

**Antenna 2 (Chain 1)**

Freq. [MHz]	Reading [dBm]	Cable Loss [dB]	Atten. Loss [dB]	Result		Directional Gain [dBi]
				[dBm]	[mW]	
2412	7.21	2.40	10.18	19.79	95.28	0.93
2437	8.36	2.40	10.18	20.94	124.17	0.93
2462	7.77	2.41	10.18	20.36	108.64	0.93

Sample Calculation:

Result = Reading + Cable Loss (including the cable(s) customer supplied) + Attenuator Loss

Directional Gain = G ANT + Array Gain

G ANT = Set equal to the gain of the antenna having the highest gain

Array Gain = 0 dB(i.e.,no array gain) for N ANT < 4

N ANT = number of transmit antennas = 2

**Serial No. B-2**

**Antenna 1 + Antenna 2**

Freq. [MHz]	Antenna 1 (Chain 0) Result [mW]	Antenna 2 (Chain 1) Result [mW]	Conducted Power					e.i.r.p.				
			Result		Limit		Margin [dB]	Result		Limit		Margin [dB]
			[dBm]	[mW]	[dBm]	[mW]		[dBm]	[mW]	[dBm]	[mW]	
2412	95.28	104.47	23.00	199.75	30.00	1000	7.00	24.98	315.13	36.02	4000.00	11.04
2437	105.20	108.64	<b>23.30</b>	<b>213.84</b>	30.00	1000	6.70	<b>25.28</b>	<b>337.35</b>	36.02	4000.00	10.74
2462	83.56	103.04	22.71	186.60	30.00	1000	7.29	24.69	294.38	36.02	4000.00	11.33

Sample Calculation:

Result [mW] = Antenna 1 [mW] + Antenna 2 [mW]

e.i.r.p. Result [mW] =  $10^{\wedge}((\text{Antenna 1 Result [dBm]} + \text{Directional Gain [dBi]})/10) + 10^{\wedge}((\text{Antenna 2 Result [dBm]} + \text{Directional Gain [dBi]})/10)$

**Antenna 1 (Chain 0)**

Freq. [MHz]	Reading [dBm]	Cable Loss [dB]	Atten. Loss [dB]	Result		Directional Gain [dBi]
				[dBm]	[mW]	
2412	7.70	2.27	9.82	19.79	95.28	1.98
2437	8.10	2.30	9.82	20.22	105.20	1.98
2462	7.09	2.31	9.82	19.22	83.56	1.98

**Antenna 2 (Chain 1)**

Freq. [MHz]	Reading [dBm]	Cable Loss [dB]	Atten. Loss [dB]	Result		Directional Gain [dBi]
				[dBm]	[mW]	
2412	7.53	2.48	10.18	20.19	104.47	1.98
2437	7.70	2.48	10.18	20.36	108.64	1.98
2462	7.46	2.49	10.18	20.13	103.04	1.98

Sample Calculation:

Result = Reading + Cable Loss (including the cable(s) customer supplied) + Attenuator Loss

Directional Gain = G ANT + Array Gain

G ANT = Set equal to the gain of the antenna having the highest gain

Array Gain = 0 dB(i.e.,no array gain) for N ANT < 4

N ANT = number of transmit antennas = 2

**UL Japan, Inc.**

**Shonan EMC Lab.**

1-22-3 Megumigaoka, Hiratsuka-shi, Kanagawa-ken, 259-1220 JAPAN

Telephone : +81 463 50 6400

Facsimile : +81 463 50 6401

## Maximum Peak Output Power

Report No. 13004393S-A-R2  
Test place Shonan EMC Lab. No.3 Shielded Room  
Date September 23, 2019  
Temperature / Humidity 24 deg. C / 42 % RH  
Engineer Hiromasa Sato  
Mode Tx, 11n-20 MIMO low power

Serial No. : A-1

Antenna 1 + Antenna 2			Conducted Power					e.i.r.p.				
Freq. [MHz]	Antenna 1 (Chain 0) Result [mW]	Antenna 2 (Chain 1) Result [mW]	Result		Limit		Margin [dB]	Result		Limit		Margin [dB]
			[dBm]	[mW]	[dBm]	[mW]		[dBm]	[mW]	[dBm]	[mW]	
2412	94.84	96.83	22.83	191.67	30.00	1000	7.17	23.76	237.44	36.02	4000.00	12.27
2437	104.47	110.92	<b>23.33</b>	<b>215.39</b>	30.00	1000	6.67	<b>24.26</b>	<b>266.82</b>	36.02	4000.00	11.76
2462	83.95	106.41	22.80	190.36	30.00	1000	7.20	23.73	235.82	36.02	4000.00	12.29

Sample Calculation:

Result [mW] = Antenna 1 [mW] + Antenna 2 [mW]

e.i.r.p. Result [mW] =  $10^{((\text{Antenna 1 Result [dBm]} + \text{Antenna1 Gain [dBi]} ) / 10)} + 10^{((\text{Antenna 2 Result [dBm]} + \text{Antenna2 Gain [dBi]} ) / 10)}$

Antenna 1 (Chain 0)

Freq. [MHz]	Reading [dBm]	Cable Loss [dB]	Atten. Loss [dB]	Result		Antenna 1 Gain [dBi]
				[dBm]	[mW]	
2412	7.68	2.27	9.82	19.77	94.84	0.93
2437	8.07	2.30	9.82	20.19	104.47	0.93
2462	7.11	2.31	9.82	19.24	83.95	0.93

Antenna 2 (Chain 1)

Freq. [MHz]	Reading [dBm]	Cable Loss [dB]	Atten. Loss [dB]	Result		Antenna 2 Gain [dBi]
				[dBm]	[mW]	
2412	7.28	2.40	10.18	19.86	96.83	0.93
2437	7.87	2.40	10.18	20.45	110.92	0.93
2462	7.68	2.41	10.18	20.27	106.41	0.93

Sample Calculation:

Result = Reading + Cable Loss (including the cable(s) customer supplied) + Attenuator Loss

Serial No. B-2

Antenna 1 + Antenna 2			Conducted Power					e.i.r.p.				
Freq. [MHz]	Antenna 1 (Chain 0) Result [mW]	Antenna 2 (Chain 1) Result [mW]	Result		Limit		Margin [dB]	Result		Limit		Margin [dB]
			[dBm]	[mW]	[dBm]	[mW]		[dBm]	[mW]	[dBm]	[mW]	
2412	107.15	117.49	<b>23.51</b>	<b>224.64</b>	30.00	1000	6.49	<b>25.03</b>	<b>318.09</b>	36.02	4000.00	11.00
2437	95.94	110.41	23.15	206.35	30.00	1000	6.85	24.67	293.03	36.02	4000.00	11.35
2462	92.68	123.31	23.34	215.99	30.00	1000	6.66	24.90	309.35	36.02	4000.00	11.12

Sample Calculation:

Result [mW] = Antenna 1 [mW] + Antenna 2 [mW]

e.i.r.p. Result [mW] =  $10^{((\text{Antenna 1 Result [dBm]} + \text{Antenna1 Gain [dBi]} ) / 10)} + 10^{((\text{Antenna 2 Result [dBm]} + \text{Antenna2 Gain [dBi]} ) / 10)}$

Antenna 1 (Chain 0)

Freq. [MHz]	Reading [dBm]	Cable Loss [dB]	Atten. Loss [dB]	Result		Antenna 1 Gain [dBi]
				[dBm]	[mW]	
2412	8.21	2.27	9.82	20.30	107.15	0.93
2437	7.70	2.30	9.82	19.82	95.94	0.93
2462	7.54	2.31	9.82	19.67	92.68	0.93

Antenna 2 (Chain 1)

Freq. [MHz]	Reading [dBm]	Cable Loss [dB]	Atten. Loss [dB]	Result		Antenna 2 Gain [dBi]
				[dBm]	[mW]	
2412	8.04	2.48	10.18	20.70	117.49	1.98
2437	7.77	2.48	10.18	20.43	110.41	1.98
2462	8.24	2.49	10.18	20.91	123.31	1.98

Sample Calculation:

Result = Reading + Cable Loss (including the cable(s) customer supplied) + Attenuator Loss

**UL Japan, Inc.**

**Shonan EMC Lab.**

1-22-3 Megumigaoka, Hiratsuka-shi, Kanagawa-ken, 259-1220 JAPAN

Telephone : +81 463 50 6400

Facsimile : +81 463 50 6401

## Maximum Peak Output Power

Report No. 13004393S-A-R2  
Test place Shonan EMC Lab. No.3 Shielded Room  
Date September 17, 2019  
Temperature / Humidity 24 deg. C / 57 % RH  
Engineer Kazuya Noda  
Mode Tx, BT LE

Freq. [MHz]	Reading [dBm]	Cable Loss [dB]	Atten. Loss [dB]	Conducted Power					e.i.r.p. for RSS-247					
				Result		Limit		Margin [dB]	Antenna Gain [dBi]	Result		Limit		Margin [dB]
				[dBm]	[mW]	[dBm]	[mW]			[dBm]	[mW]	[dBm]	[mW]	
2402	-1.27	1.32	9.92	9.97	9.93	30.00	1000	20.03	0.93	10.90	12.30	36.02	4000	25.12
2440	-1.27	1.34	9.92	<b>9.99</b>	<b>9.98</b>	30.00	1000	20.01	0.93	10.92	12.36	36.02	4000	25.10
2480	-1.31	1.33	9.92	9.94	9.86	30.00	1000	20.06	0.93	10.87	12.22	36.02	4000	25.15

Sample Calculation:

Result = Reading + Cable Loss (including the cable(s) customer supplied) + Attenuator Loss

e.i.r.p. Result = Conducted Power Result + Antenna Gain

\*The equipment and cables were not used for factor 0 dB of the data sheets.

**UL Japan, Inc.**

**Shonan EMC Lab.**

1-22-3 Megumigaoka, Hiratsuka-shi, Kanagawa-ken, 259-1220 JAPAN

Telephone : +81 463 50 6400

Facsimile : +81 463 50 6401

## Maximum Peak Output Power

Report No. 13004393S-A-R2  
Test place Shonan EMC Lab. No.3 Shielded Room  
Date September 4, 2019  
Temperature / Humidity 26 deg. C / 49 % RH  
Engineer Kenichi Adachi  
Mode Tx, 11b, (Serial No.: A-1)

**2412 MHz**

Mbps	Antenna 1 (Chain 0)					Antenna 2 (Chain 1)					Total Power	
	Reading (Peak) [dBm]	Cable Loss [dB]	Atten. Loss [dB]	Result (Peak)		Reading (Peak) [dBm]	Cable Loss [dB]	Atten. Loss [dB]	Result (Peak)		Result (Peak)	
				[dBm]	[mW]				[dBm]	[mW]	[dBm]	[mW]
1 (L)	3.39	2.27	9.82	15.48	35.35	3.56	2.40	10.18	16.14	41.09	18.83	76.44
2 (L)	3.56	2.27	9.82	15.65	36.76	3.58	2.40	10.18	16.16	41.28	18.92	78.04
5.5 (L)	3.28	2.27	9.82	15.37	34.47	3.54	2.40	10.18	16.12	40.90	18.77	75.37
11 (L)	3.34	2.27	9.82	15.43	34.94	3.52	2.40	10.18	16.10	40.71	18.79	75.66
2 (S)	3.68	2.27	9.82	15.77	37.79	3.78	2.40	10.18	16.36	43.23	<b>19.09</b>	<b>81.02</b>
5.5 (S)	3.64	2.27	9.82	15.73	37.44	3.74	2.40	10.18	16.32	42.83	19.05	80.27
11 (S)	3.72	2.27	9.82	15.81	38.14	3.74	2.40	10.18	16.32	42.83	19.08	80.97

\* (L): Long preamble, (S): Short preamble

**2412 MHz**

Mbps	Antenna 1 (Chain 0)					Antenna 2 (Chain 1)					Total Power	
	Reading (Average) [dBm]	Cable Loss [dB]	Atten. Loss [dB]	Result (Average)		Reading (Average) [dBm]	Cable Loss [dB]	Atten. Loss [dB]	Result (Average)		Result (Average)	
				[dBm]	[mW]				[dBm]	[mW]	[dBm]	[mW]
1 (L)	0.83	2.27	9.82	12.92	19.61	0.28	2.40	10.18	12.86	19.31	15.90	38.91
2 (L)	0.85	2.27	9.82	12.94	19.70	0.37	2.40	10.18	12.95	19.71	15.96	39.41
5.5 (L)	0.82	2.27	9.82	12.91	19.56	0.27	2.40	10.18	12.85	19.26	15.89	38.83
11 (L)	0.79	2.27	9.82	12.88	19.43	0.32	2.40	10.18	12.90	19.49	15.90	38.91
2 (S)	1.08	2.27	9.82	13.17	20.77	0.70	2.40	10.18	13.28	21.27	<b>16.24</b>	<b>42.04</b>
5.5 (S)	1.06	2.27	9.82	13.15	20.67	0.56	2.40	10.18	13.14	20.59	16.16	41.27
11 (S)	1.08	2.27	9.82	13.17	20.77	0.58	2.40	10.18	13.16	20.69	16.18	41.46

\* (L): Long preamble, (S): Short preamble

Sample Calculation:

Result [dBm] = Reading + Cable Loss + Attenuator Loss

Result [mW] =  $10^{(\text{Result [dBm]} / 10)}$

Total Result [mW] = Antenna 0 Result [mW] + Antenna 1 Result [mW]

Total Result [dBm] =  $10 \times \log(\text{Total Result [mW]})$

## Maximum Peak Output Power

Report No. 13004393S-A-R2  
Test place Shonan EMC Lab. No.3 Shielded Room  
Date September 4, 2019  
Temperature / Humidity 26 deg. C / 49 % RH  
Engineer Kenichi Adachi  
Mode Tx, 11g, (Serial No.: A-1)

**2412 MHz**

Mbps	Antenna 1 (Chain 0)					Antenna 2 (Chain 1)					Total Power	
	Reading (Peak) [dBm]	Cable Loss [dB]	Atten. Loss [dB]	Result (Peak)		Reading (Peak) [dBm]	Cable Loss [dB]	Atten. Loss [dB]	Result (Peak)		Result (Peak)	
				[dBm]	[mW]				[dBm]	[mW]	[dBm]	[mW]
6	7.32	2.27	9.82	19.41	87.37	6.97	2.40	10.18	19.55	90.11	22.49	177.48
9	7.31	2.27	9.82	19.40	87.17	7.26	2.40	10.18	19.84	96.33	22.64	183.50
12	7.34	2.27	9.82	19.43	87.78	7.03	2.40	10.18	19.61	91.36	22.53	179.14
18	7.50	2.27	9.82	19.59	91.07	7.21	2.40	10.18	19.79	95.23	22.70	186.30
24	11.14	2.27	9.82	23.23	210.56	10.32	2.40	10.18	22.90	194.87	26.08	405.44
36	11.00	2.27	9.82	23.09	203.88	10.76	2.40	10.18	23.34	215.65	<b>26.23</b>	<b>419.54</b>
48	11.45	2.27	9.82	23.54	226.14	10.28	2.40	10.18	22.86	193.09	26.22	419.23
54	10.98	2.27	9.82	23.07	202.95	10.18	2.40	10.18	22.76	188.69	25.93	391.64

**2412 MHz**

Mbps	Antenna 1 (Chain 0)					Antenna 2 (Chain 1)					Total Power	
	Reading (Average) [dBm]	Cable Loss [dB]	Atten. Loss [dB]	Result (Average)		Reading (Average) [dBm]	Cable Loss [dB]	Atten. Loss [dB]	Result (Average)		Result (Average)	
				[dBm]	[mW]				[dBm]	[mW]	[dBm]	[mW]
6	0.72	2.27	9.82	12.81	19.12	0.47	2.40	10.18	13.05	20.17	15.94	39.29
9	0.76	2.27	9.82	12.85	19.29	0.41	2.40	10.18	12.99	19.90	15.93	39.19
12	0.69	2.27	9.82	12.78	18.98	0.41	2.40	10.18	12.99	19.90	15.90	38.88
18	0.73	2.27	9.82	12.82	19.16	0.47	2.40	10.18	13.05	20.17	15.95	39.33
24	1.05	2.27	9.82	13.14	20.62	0.86	2.40	10.18	13.44	22.07	16.30	42.69
36	1.07	2.27	9.82	13.16	20.72	0.88	2.40	10.18	13.46	22.17	<b>16.32</b>	<b>42.89</b>
48	1.11	2.27	9.82	13.20	20.91	0.80	2.40	10.18	13.38	21.76	16.30	42.68
54	1.12	2.27	9.82	13.21	20.96	0.83	2.40	10.18	13.41	21.92	16.32	42.88

**Sample Calculation:**

Result [dBm] = Reading + Cable Loss + Attenuator Loss  
Result [mW] = 10<sup>^</sup> ( Result [dBm] / 10 )  
Total Result [mW] = Antenna 0 Result [mW] + Antenna 1 Result [mW]  
Total Result [dBm] = 10 x log ( Total Result [mW] )

## Maximum Peak Output Power

Report No. 13004393S-A-R2  
Test place Shonan EMC Lab. No.3 Shielded Room  
Date September 3, 2019  
Temperature / Humidity 26 deg. C / 49 % RH  
Engineer Makoto Hosaka  
Mode Tx, 11n-20 CDD, (Serial No.: A-1)

**2412 MHz**

MCS	Antenna 1 (Chain 0)					Antenna 2 (Chain 1)					Total Power	
	Reading (Peak) [dBm]	Cable Loss [dB]	Atten. Loss [dB]	Result (Peak)		Reading (Peak) [dBm]	Cable Loss [dB]	Atten. Loss [dB]	Result (Peak)		Result (Peak)	
				[dBm]	[mW]				[dBm]	[mW]	[dBm]	[mW]
0	6.96	2.27	9.82	19.05	80.42	6.98	2.40	10.18	19.56	90.31	22.32	170.74
1	6.92	2.27	9.82	19.01	79.69	6.96	2.40	10.18	19.54	89.90	22.29	169.59
2	6.99	2.27	9.82	19.08	80.98	6.91	2.40	10.18	19.49	88.87	22.30	169.85
3	10.72	2.27	9.82	22.81	191.15	10.11	2.40	10.18	22.69	185.68	25.76	376.83
4	11.65	2.27	9.82	23.74	236.80	10.27	2.40	10.18	22.85	192.64	26.33	429.44
5	10.84	2.27	9.82	22.93	196.51	10.12	2.40	10.18	22.70	186.10	25.83	382.61
6	11.04	2.27	9.82	23.13	205.77	10.03	2.40	10.18	22.61	182.29	25.89	388.06
7	12.48	2.27	9.82	24.57	286.67	10.47	2.40	10.18	23.05	201.72	<b>26.89</b>	<b>488.39</b>

**2412 MHz**

MCS	Antenna 1 (Chain 0)					Antenna 2 (Chain 1)					Total Power	
	Reading (Average) [dBm]	Cable Loss [dB]	Atten. Loss [dB]	Result (Average)		Reading (Average) [dBm]	Cable Loss [dB]	Atten. Loss [dB]	Result (Average)		Result (Average)	
				[dBm]	[mW]				[dBm]	[mW]	[dBm]	[mW]
0	0.05	2.27	9.82	12.14	16.38	-0.23	2.40	10.18	12.35	17.17	15.26	33.55
1	0.04	2.27	9.82	12.13	16.34	-0.23	2.40	10.18	12.35	17.17	15.25	33.51
2	0.04	2.27	9.82	12.13	16.34	-0.22	2.40	10.18	12.36	17.21	15.26	33.55
3	0.58	2.27	9.82	12.67	18.51	0.41	2.40	10.18	12.99	19.90	15.84	38.40
4	0.53	2.27	9.82	12.62	18.30	0.47	2.40	10.18	13.05	20.17	15.85	38.47
5	0.52	2.27	9.82	12.61	18.26	0.44	2.40	10.18	13.02	20.03	15.83	38.29
6	0.53	2.27	9.82	12.62	18.30	0.42	2.40	10.18	13.00	19.94	15.83	38.24
7	0.62	2.27	9.82	12.71	18.68	0.50	2.40	10.18	13.08	20.31	<b>15.91</b>	<b>38.99</b>

Sample Calculation:

Result [dBm] = Reading + Cable Loss + Attenuator Loss

Result [mW] =  $10^{( \text{Result [dBm]} / 10 )}$

Total Result [mW] = Antenna 0 Result [mW] + Antenna 1 Result [mW]

Total Result [dBm] =  $10 \times \log(\text{Total Result [mW]})$

**UL Japan, Inc.**

**Shonan EMC Lab.**

1-22-3 Megumigaoka, Hiratsuka-shi, Kanagawa-ken, 259-1220 JAPAN

Telephone : +81 463 50 6400

Facsimile : +81 463 50 6401

## Maximum Peak Output Power

Report No. 13004393S-A-R2  
Test place Shonan EMC Lab. No.3 Shielded Room  
Date September 3, 2019  
Temperature / Humidity 26 deg. C / 49 % RH  
Engineer Makoto Hosaka  
Mode Tx, 11n-20 MIMO, (Serial No.: A-1)

**2412 MHz**

MCS	Antenna 1 (Chain 0)					Antenna 2 (Chain 1)					Total Power	
	Reading (Peak) [dBm]	Cable Loss [dB]	Atten. Loss [dB]	Result (Peak)		Reading (Peak) [dBm]	Cable Loss [dB]	Atten. Loss [dB]	Result (Peak)		Result (Peak)	
				[dBm]	[mW]				[dBm]	[mW]	[dBm]	[mW]
8	6.86	2.27	9.82	18.95	78.59	6.92	2.40	10.18	19.50	89.07	22.24	167.67
9	6.83	2.27	9.82	18.92	78.05	7.16	2.40	10.18	19.74	94.14	22.36	172.19
10	6.89	2.27	9.82	18.98	79.14	6.87	2.40	10.18	19.45	88.06	22.23	167.19
11	11.01	2.27	9.82	23.10	204.35	11.71	2.40	10.18	24.29	268.38	26.75	472.74
12	11.37	2.27	9.82	23.46	222.02	11.83	2.40	10.18	24.41	275.90	26.97	497.92
13	10.97	2.27	9.82	23.06	202.48	11.67	2.40	10.18	24.25	265.92	26.71	468.40
14	10.67	2.27	9.82	22.76	188.97	10.25	2.40	10.18	22.83	191.76	25.81	380.72
15	11.69	2.27	9.82	23.78	238.99	12.48	2.40	10.18	25.06	320.45	27.48	559.44

**2412 MHz**

MCS	Antenna 1 (Chain 0)					Antenna 2 (Chain 1)					Total Power	
	Reading (Average) [dBm]	Cable Loss [dB]	Atten. Loss [dB]	Result (Average)		Reading (Average) [dBm]	Cable Loss [dB]	Atten. Loss [dB]	Result (Average)		Result (Average)	
				[dBm]	[mW]				[dBm]	[mW]	[dBm]	[mW]
8	0.01	2.27	9.82	12.10	16.23	-0.23	2.40	10.18	12.35	17.17	15.24	33.40
9	0.02	2.27	9.82	12.11	16.27	-0.23	2.40	10.18	12.35	17.17	15.24	33.44
10	0.02	2.27	9.82	12.11	16.27	-0.11	2.40	10.18	12.47	17.65	15.30	33.92
11	0.54	2.27	9.82	12.63	18.34	0.30	2.40	10.18	12.88	19.40	15.77	37.74
12	0.51	2.27	9.82	12.60	18.21	0.44	2.40	10.18	13.02	20.03	15.83	38.25
13	0.60	2.27	9.82	12.69	18.59	0.42	2.40	10.18	13.00	19.94	15.86	38.54
14	0.58	2.27	9.82	12.67	18.51	0.52	2.40	10.18	13.10	20.41	15.90	38.91
15	0.62	2.27	9.82	12.71	18.68	0.50	2.40	10.18	13.08	20.31	15.91	38.99

**Sample Calculation:**

Result [dBm] = Reading + Cable Loss + Attenuator Loss  
Result [mW] = 10<sup>( Result [dBm] / 10 )</sup>  
Total Result [mW] = Antenna 0 Result [mW] + Antenna 1 Result [mW]  
Total Result [dBm] = 10 x log ( Total Result [mW] )

**Average Output Power**  
**(Reference data for RF Exposure)**

Report No. 13004393S-A-R2  
Test place Shonan EMC Lab. No.3 Shielded Room  
Date September 4, 2019 September 5, 2019 September 3, 2019  
Temperature / Humidity 26 deg. C / 49 % RH 26 deg. C / 49 % RH 26 deg. C / 49 % RH  
Engineer Kenichi Adachi Hiromasa Sato Makoto Hosaka  
Mode Tx, (Serial No.: A-1) high power

11b

Frequency [MHz]	Antenna 1 (Chain 0)					Antenna 2 (Chain 1)					Total Power	
	Reading (Average) [dBm]	Cable Loss [dB]	Atten. Loss [dB]	Result (Peak)		Reading (Average) [dBm]	Cable Loss [dB]	Atten. Loss [dB]	Result (Average)		Result (Average)	
				[dBm]	[mW]				[dBm]	[mW]	[dBm]	[mW]
2412	1.08	2.27	9.82	13.17	20.75	0.70	2.40	10.18	13.28	21.28	16.24	42.03
2437	0.51	2.30	9.82	12.63	18.32	0.40	2.40	10.18	12.98	19.86	15.82	38.18
2462	0.88	2.31	9.82	13.01	20.00	0.79	2.41	10.18	13.38	21.78	16.21	41.78

11g

Frequency [MHz]	Antenna 1 (Chain 0)					Antenna 2 (Chain 1)					Total Power	
	Reading (Average) [dBm]	Cable Loss [dB]	Atten. Loss [dB]	Result (Peak)		Reading (Average) [dBm]	Cable Loss [dB]	Atten. Loss [dB]	Result (Average)		Result (Average)	
				[dBm]	[mW]				[dBm]	[mW]	[dBm]	[mW]
2412	0.75	2.27	9.82	12.84	19.23	0.73	2.40	10.18	13.31	21.43	16.09	40.66
2437	0.71	2.30	9.82	12.83	19.19	0.86	2.40	10.18	13.44	22.08	16.16	41.27
2462	0.61	2.31	9.82	12.74	18.79	0.88	2.41	10.18	13.47	22.23	16.13	41.03

11n-20 CDD

Frequency [MHz]	Antenna 1 (Chain 0)					Antenna 2 (Chain 1)					Total Power	
	Reading (Average) [dBm]	Cable Loss [dB]	Atten. Loss [dB]	Result (Peak)		Reading (Average) [dBm]	Cable Loss [dB]	Atten. Loss [dB]	Result (Average)		Result (Average)	
				[dBm]	[mW]				[dBm]	[mW]	[dBm]	[mW]
2412	0.62	2.27	9.82	12.71	18.66	0.50	2.40	10.18	13.08	20.32	15.91	38.99
2437	0.42	2.30	9.82	12.54	17.95	0.48	2.40	10.18	13.06	20.23	15.82	38.18
2462	0.37	2.31	9.82	12.50	17.78	0.43	2.41	10.18	13.02	20.04	15.78	37.83

11n-20 MIMO

Frequency [MHz]	Antenna 1 (Chain 0)					Antenna 2 (Chain 1)					Total Power	
	Reading (Average) [dBm]	Cable Loss [dB]	Atten. Loss [dB]	Result (Peak)		Reading (Average) [dBm]	Cable Loss [dB]	Atten. Loss [dB]	Result (Average)		Result (Average)	
				[dBm]	[mW]				[dBm]	[mW]	[dBm]	[mW]
2412	0.62	2.27	9.82	12.71	18.66	0.50	2.40	10.18	13.08	20.32	15.91	38.99
2437	0.51	2.30	9.82	12.63	18.32	0.47	2.40	10.18	13.05	20.18	15.86	38.51
2462	0.37	2.31	9.82	12.50	17.78	0.43	2.41	10.18	13.02	20.04	15.78	37.83

Sample Calculation:

Result [dBm] = Reading + Cable Loss + Attenuator Loss  
Result [mW] = 10<sup>^</sup>( Result [dBm] / 10 )  
Total Result [mW] = Antenna 0 Result [mW] + Antenna 1 Result [mW]  
Total Result [dBm] = 10 x log ( Total Result [mW] )

(\*1) Power was measured with using the gate function of power meter.

It means that the intervals during which the transmitter is off or is transmitting at reduced power level is not included in the average.

Therefore, there is no need to add duty cycle correction to the result.

\*The equipment and cables were not used for factor 0 dB of the data sheets.



**Average Output Power**  
**(Reference data for RF Exposure)**

Report No. 13004393S-A-R2  
Test place Shonan EMC Lab. No.3 Shielded Room  
Date September 6, 2019 September 3, 2019  
Temperature / Humidity 24 deg. C / 50 % RH 26 deg. C / 49 % RH  
Engineer Hiromasa Sato Makoto Hosaka  
Mode Tx, (Serial No.: B-2) high power

11b

Frequency [MHz]	Antenna 1 (Chain 0)					Antenna 2 (Chain 1)					Total Power	
	Reading (Average) [dBm]	Cable Loss [dB]	Atten. Loss [dB]	Result (Peak)		Reading (Average) [dBm]	Cable Loss [dB]	Atten. Loss [dB]	Result (Average)		Result (Average)	
				[dBm]	[mW]				[dBm]	[mW]	[dBm]	[mW]
2412	0.71	2.27	9.82	12.80	19.05	0.63	2.48	10.18	13.29	21.33	16.06	40.39
2437	0.73	2.30	9.82	12.85	19.28	0.67	2.48	10.18	13.33	21.53	16.11	40.80
2462	0.46	2.31	9.82	12.59	18.16	0.53	2.49	10.18	13.20	20.89	15.92	39.05

11g

Frequency [MHz]	Antenna 1 (Chain 0)					Antenna 2 (Chain 1)					Total Power	
	Reading (Average) [dBm]	Cable Loss [dB]	Atten. Loss [dB]	Result (Peak)		Reading (Average) [dBm]	Cable Loss [dB]	Atten. Loss [dB]	Result (Average)		Result (Average)	
				[dBm]	[mW]				[dBm]	[mW]	[dBm]	[mW]
2412	0.71	2.27	9.82	12.80	19.05	0.66	2.48	10.18	13.32	21.48	16.08	40.53
2437	0.59	2.30	9.82	12.71	18.66	0.64	2.48	10.18	13.30	21.38	16.03	40.04
2462	0.46	2.31	9.82	12.59	18.16	0.45	2.49	10.18	13.12	20.51	15.87	38.67

11n-20 CDD

Frequency [MHz]	Antenna 1 (Chain 0)					Antenna 2 (Chain 1)					Total Power	
	Reading (Average) [dBm]	Cable Loss [dB]	Atten. Loss [dB]	Result (Peak)		Reading (Average) [dBm]	Cable Loss [dB]	Atten. Loss [dB]	Result (Average)		Result (Average)	
				[dBm]	[mW]				[dBm]	[mW]	[dBm]	[mW]
2412	2.27	2.27	9.82	14.36	27.31	0.69	2.48	10.18	13.35	21.63	16.90	48.94
2437	2.30	2.30	9.82	14.42	27.65	0.57	2.48	10.18	13.23	21.04	16.87	48.69
2462	2.31	2.31	9.82	14.44	27.80	0.44	2.49	10.18	13.11	20.46	16.84	48.26

11n-20 MIMO

Frequency [MHz]	Antenna 1 (Chain 0)					Antenna 2 (Chain 1)					Total Power	
	Reading (Average) [dBm]	Cable Loss [dB]	Atten. Loss [dB]	Result (Peak)		Reading (Average) [dBm]	Cable Loss [dB]	Atten. Loss [dB]	Result (Average)		Result (Average)	
				[dBm]	[mW]				[dBm]	[mW]	[dBm]	[mW]
2412	0.66	2.27	9.82	12.75	18.84	0.68	2.48	10.18	13.34	21.58	16.07	40.41
2437	0.58	2.30	9.82	12.70	18.62	0.65	2.48	10.18	13.31	21.43	16.03	40.05
2462	0.44	2.31	9.82	12.57	18.07	0.58	2.49	10.18	13.25	21.13	15.93	39.21

Sample Calculation:

Result [dBm] = Reading + Cable Loss + Attenuator Loss  
Result [mW] = 10<sup>^</sup> ( Result [dBm] / 10 )  
Total Result [mW] = Antenna 0 Result [mW] + Antenna 1 Result [mW]  
Total Result [dBm] = 10 x log ( Total Result [mW] )

(\*1) Power was measured with using the gate function of power meter.

It means that the intervals during which the transmitter is off or is transmitting at reduced power level is not included in the average.

Therefore, there is no need to add duty cycle correction to the result.

\*The equipment and cables were not used for factor 0 dB of the data sheets.

**Average Output Power**  
**(Reference data for RF Exposure)**

Report No. 13004393S-A-R2  
Test place Shonan EMC Lab. No.3 Shielded Room  
Date September 23, 2019  
Temperature / Humidity 24 deg. C / 42 % RH  
Engineer Hiromasa Sato  
Mode Tx, (Serial No.: A-1) low power

11b

Frequency [MHz]	Antenna 1 (Chain 0)					Antenna 2 (Chain 1)					Total Power	
	Reading (Average) [dBm]	Cable Loss [dB]	Atten. Loss [dB]	Result (Peak)		Reading (Average) [dBm]	Cable Loss [dB]	Atten. Loss [dB]	Result (Average)		Result (Average)	
				[dBm]	[mW]				[dBm]	[mW]	[dBm]	[mW]
2412	-2.86	2.27	9.82	9.23	8.38	-3.32	2.40	10.18	9.26	8.43	12.26	16.81
2437	-2.85	2.30	9.82	9.27	8.45	-3.14	2.40	10.18	9.44	8.79	<b>12.37</b>	<b>17.24</b>
2462	-3.07	2.31	9.82	9.06	8.05	-3.22	2.41	10.18	9.37	8.65	12.23	16.70

11g

Frequency [MHz]	Antenna 1 (Chain 0)					Antenna 2 (Chain 1)					Total Power	
	Reading (Average) [dBm]	Cable Loss [dB]	Atten. Loss [dB]	Result (Peak)		Reading (Average) [dBm]	Cable Loss [dB]	Atten. Loss [dB]	Result (Average)		Result (Average)	
				[dBm]	[mW]				[dBm]	[mW]	[dBm]	[mW]
2412	-2.90	2.27	9.82	9.19	8.30	-3.36	2.40	10.18	9.22	8.36	12.22	16.65
2437	-2.93	2.30	9.82	9.19	8.30	-3.35	2.40	10.18	9.23	8.38	<b>12.22</b>	<b>16.67</b>
2462	-3.11	2.31	9.82	9.02	7.98	-3.45	2.41	10.18	9.14	8.20	12.09	16.18

11n-20 CDD

Frequency [MHz]	Antenna 1 (Chain 0)					Antenna 2 (Chain 1)					Total Power	
	Reading (Average) [dBm]	Cable Loss [dB]	Atten. Loss [dB]	Result (Peak)		Reading (Average) [dBm]	Cable Loss [dB]	Atten. Loss [dB]	Result (Average)		Result (Average)	
				[dBm]	[mW]				[dBm]	[mW]	[dBm]	[mW]
2412	-3.01	2.27	9.82	9.08	8.09	-3.32	2.40	10.18	9.26	8.43	12.18	16.52
2437	-3.14	2.30	9.82	8.98	7.91	-3.20	2.40	10.18	9.38	8.67	12.19	16.58
2462	-3.20	2.31	9.82	8.93	7.82	-3.14	2.41	10.18	9.45	8.81	<b>12.21</b>	<b>16.63</b>

11n-20 MIMO

Frequency [MHz]	Antenna 1 (Chain 0)					Antenna 2 (Chain 1)					Total Power	
	Reading (Average) [dBm]	Cable Loss [dB]	Atten. Loss [dB]	Result (Peak)		Reading (Average) [dBm]	Cable Loss [dB]	Atten. Loss [dB]	Result (Average)		Result (Average)	
				[dBm]	[mW]				[dBm]	[mW]	[dBm]	[mW]
2412	-2.98	2.27	9.82	9.11	8.15	-3.33	2.40	10.18	9.25	8.41	<b>12.19</b>	<b>16.56</b>
2437	-3.11	2.30	9.82	9.01	7.96	-3.27	2.40	10.18	9.31	8.53	12.17	16.49
2462	-3.25	2.31	9.82	8.88	7.73	-3.42	2.41	10.18	9.17	8.26	12.04	15.99

Sample Calculation:

Result [dBm] = Reading + Cable Loss + Attenuator Loss  
Result [mW] = 10<sup>(Result [dBm] / 10)</sup>  
Total Result [mW] = Antenna 0 Result [mW] + Antenna 1 Result [mW]  
Total Result [dBm] = 10 × log (Total Result [mW])

(\*1) Power was measured with using the gate function of power meter.

It was means that the intervals during which the transmitter is off or is transmitting at reduced power level is not included in the average.

Therefore, there is no need to add duty cycle correction to the result.

\*The equipment and cables were not used for factor 0 dB of the data sheets.

**Average Output Power**  
**(Reference data for RF Exposure)**

Report No. 13004393S-A-R2  
Test place Shonan EMC Lab. No.3 Shielded Room  
Date September 23, 2019  
Temperature / Humidity 24 deg. C / 42 % RH  
Engineer Hiromasa Sato  
Mode Tx, (Serial No.: B-2) low power

11b

Frequency [MHz]	Antenna 1 (Chain 0)					Antenna 2 (Chain 1)					Total Power	
	Reading (Average) [dBm]	Cable Loss [dB]	Atten. Loss [dB]	Result (Peak)		Reading (Average) [dBm]	Cable Loss [dB]	Atten. Loss [dB]	Result (Average)		Result (Average)	
				[dBm]	[mW]				[dBm]	[mW]	[dBm]	[mW]
2412	-2.91	2.27	9.82	9.18	8.28	-3.19	2.48	10.18	9.47	8.85	<b>12.34</b>	<b>17.13</b>
2437	-3.11	2.30	9.82	9.01	7.96	-3.28	2.48	10.18	9.38	8.67	12.21	16.63
2462	-3.10	2.31	9.82	9.03	8.00	-3.37	2.49	10.18	9.30	8.51	12.18	16.51

11g

Frequency [MHz]	Antenna 1 (Chain 0)					Antenna 2 (Chain 1)					Total Power	
	Reading (Average) [dBm]	Cable Loss [dB]	Atten. Loss [dB]	Result (Peak)		Reading (Average) [dBm]	Cable Loss [dB]	Atten. Loss [dB]	Result (Average)		Result (Average)	
				[dBm]	[mW]				[dBm]	[mW]	[dBm]	[mW]
2412	-2.92	2.27	9.82	9.17	8.26	-3.52	2.48	10.18	9.14	8.20	<b>12.17</b>	<b>16.46</b>
2437	-3.21	2.30	9.82	8.91	7.78	-3.39	2.48	10.18	9.27	8.45	12.10	16.23
2462	-3.37	2.31	9.82	8.76	7.52	-3.33	2.49	10.18	9.34	8.59	12.07	16.11

11n-20 CDD

Frequency [MHz]	Antenna 1 (Chain 0)					Antenna 2 (Chain 1)					Total Power	
	Reading (Average) [dBm]	Cable Loss [dB]	Atten. Loss [dB]	Result (Peak)		Reading (Average) [dBm]	Cable Loss [dB]	Atten. Loss [dB]	Result (Average)		Result (Average)	
				[dBm]	[mW]				[dBm]	[mW]	[dBm]	[mW]
2412	-3.07	2.27	9.82	9.02	7.98	-3.46	2.48	10.18	9.20	8.32	12.12	16.30
2437	-3.01	2.30	9.82	9.11	8.15	-3.49	2.48	10.18	9.17	8.26	<b>12.15</b>	<b>16.41</b>
2462	-3.25	2.31	9.82	8.88	7.73	-3.35	2.49	10.18	9.32	8.55	12.12	16.28

11n-20 MIMO

Frequency [MHz]	Antenna 1 (Chain 0)					Antenna 2 (Chain 1)					Total Power	
	Reading (Average) [dBm]	Cable Loss [dB]	Atten. Loss [dB]	Result (Peak)		Reading (Average) [dBm]	Cable Loss [dB]	Atten. Loss [dB]	Result (Average)		Result (Average)	
				[dBm]	[mW]				[dBm]	[mW]	[dBm]	[mW]
2412	-3.16	2.27	9.82	8.93	7.82	-3.39	2.48	10.18	9.27	8.45	12.11	16.27
2437	-3.36	2.30	9.82	8.76	7.52	-3.49	2.48	10.18	9.17	8.26	11.98	15.78
2462	-3.37	2.31	9.82	8.76	7.52	-3.21	2.49	10.18	9.46	8.83	<b>12.13</b>	<b>16.35</b>

Sample Calculation:

Result [dBm] = Reading + Cable Loss + Attenuator Loss  
Result [mW] = 10<sup>^</sup> ( Result [dBm] / 10 )  
Total Result [mW] = Antenna 0 Result [mW] + Antenna 1 Result [mW]  
Total Result [dBm] = 10 x log ( Total Result [mW] )

(\*1) Power was measured with using the gate function of power meter.

It means that the intervals during which the transmitter is off or is transmitting at reduced power level is not included in the average.

Therefore, there is no need to add duty cycle correction to the result.

\*The equipment and cables were not used for factor 0 dB of the data sheets.

**Average Output Power**  
**(Reference data for RF Exposure)**

Report No. 13004393S-A-R2  
Test place Shonan EMC Lab. No.3 Shielded Room  
Date September 17, 2019  
Temperature / Humidity 24 deg. C / 57 % RH  
Engineer Kazuya Noda  
Mode Tx, BT LE

Freq. [MHz]	Reading [dBm]	Cable Loss [dB]	Atten. Loss [dB]	Result (Time average)		Duty factor [dB]	Result (Burst power average)	
				[dBm]	[mW]		[dBm]	[mW]
2402	-3.38	1.32	9.92	7.86	6.11	1.70	9.56	9.04
2440	-3.38	1.34	9.92	7.88	6.14	1.70	9.58	9.08
2480	-3.39	1.33	9.92	7.86	6.11	1.70	9.56	9.04

Sample Calculation:

Result (Time average) = Reading + Cable Loss (including the cable(s) customer supplied) + Attenuator Loss

Result (Burst power average) = Time average + Duty factor

\*The equipment and cables were not used for factor 0 dB of the data sheets.

---

**UL Japan, Inc.**

**Shonan EMC Lab.**

1-22-3 Megumigaoka, Hiratsuka-shi, Kanagawa-ken, 259-1220 JAPAN

Telephone : +81 463 50 6400

Facsimile : +81 463 50 6401

**Burst rate confirmation**

Report No. 13004393S-A-R2  
 Test place Shonan EMC Lab. No.3 Semi Anechoic Chamber  
 Date September 4, 2019 September 8, 2019 September 9, 2019  
 Temperature / Humidity 24 deg. C / 54 % RH 23 deg. C / 62 % RH 23 deg. C / 62 % RH  
 Engineer Kenichi Adachi Kenichi Adachi Kenichi Adachi  
 Mode Tx, high power

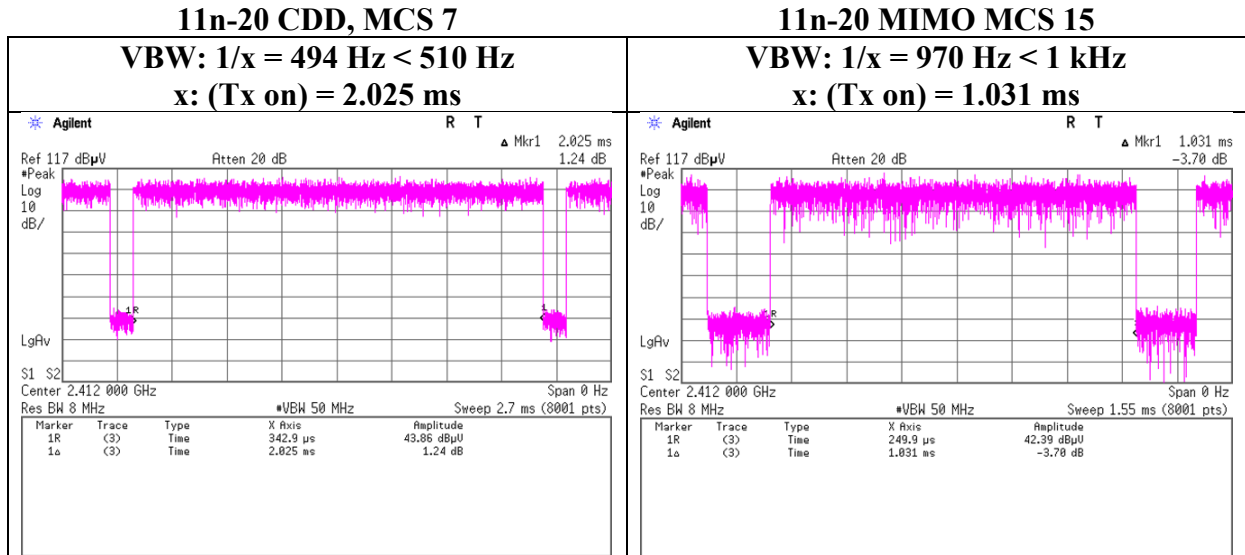
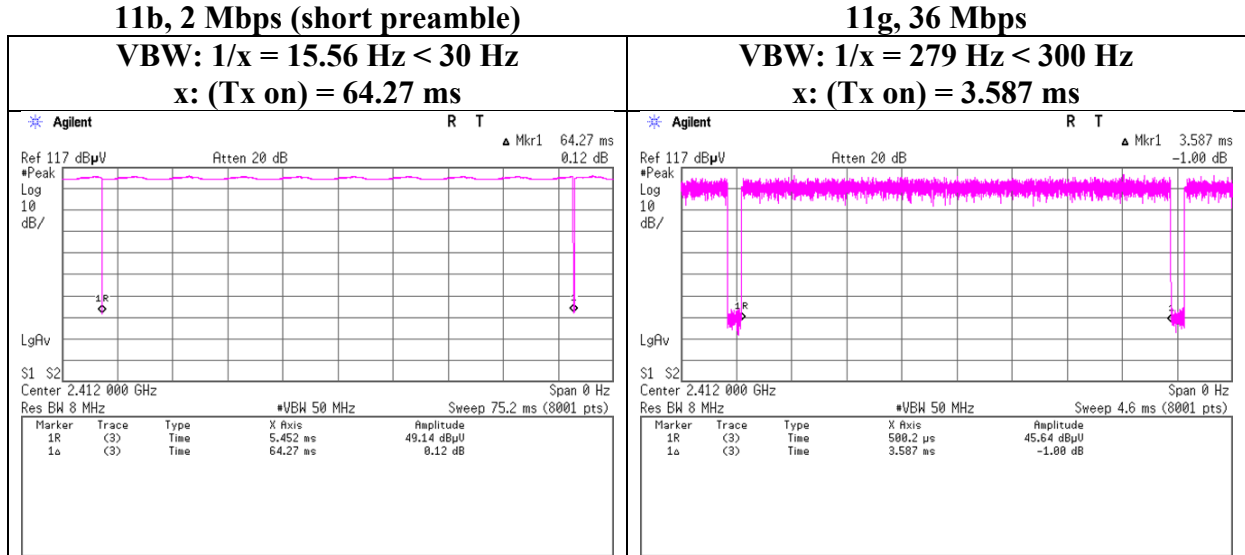

\* Since the burst rate is not different between the channels, the data has been obtained on the representative channel.

## Burst rate confirmation

Report No. 13004393S-A-R2  
 Test place Shonan EMC Lab. No.3 Shielded Room  
 Date September 17, 2019  
 Temperature / Humidity 24 deg. C / 57 % RH  
 Engineer Kazuya Noda  
 Mode Tx

### BT LE

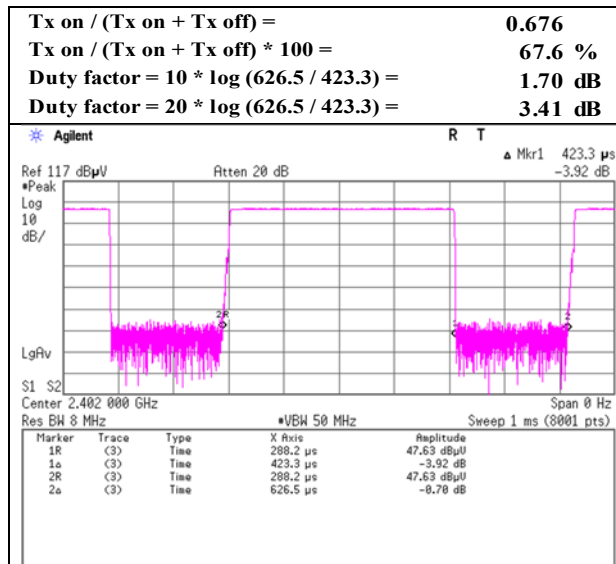

\* Since the burst rate is not different between the channels, the data has been obtained on the representative channel.

**UL Japan, Inc.**

**Shonan EMC Lab.**

1-22-3 Megumigaoka, Hiratsuka-shi, Kanagawa-ken, 259-1220 JAPAN

Telephone : +81 463 50 6400

Facsimile : +81 463 50 6401

## Radiated Spurious Emission

Report No.	13004393S-A-R2		
Test place	Shonan EMC Lab.		
Semi Anechoic Chamber	No.3	No.3	No.3
Date	September 4, 2019	September 9, 2019	September 13, 2019
Temperature / Humidity	24 deg. C / 54 % RH	24 deg.C / 52 %RH	23 deg.C / 52 %RH
Engineer	Kenichi Adachi	Kazuya Noda	Kazuya Noda
	(1 GHz – 2.8 GHz)	(2.8 GHz – 13 GHz)	(13 GHz – 26.5 GHz)
Mode	Tx, 11b, high power, 2412 MHz		
EUT Serial No.	A-1		
Antenna	Chain-0: Dual Monopole Antenna		
	Chain-1: Dual Monopole Antenna		

(\* PK: Peak, AV: Average, QP: Quasi-Peak)

Polarity	Frequency [MHz]	Detector	Reading [dBuV]	Ant.Fac. [dB/m]	Loss [dB]	Gain [dB]	Distance Factor [dB]	Result [dBuV/m]	Limit [dBuV/m]	Margin [dB]	Height [cm]	Angle [deg]	Remark
Hori.	2390.000	PK	47.83	28.33	24.34	41.59	2.15	61.06	73.9	12.8	162	75	-
Hori.	4824.000	PK	50.51	31.64	6.46	42.88	2.15	47.88	73.9	26.0	128	239	-
Hori.	7236.000	PK	48.69	37.25	7.89	42.98	2.15	53.00	73.9	20.9	100	0	-
Hori.	9648.000	PK	49.37	38.97	9.18	43.13	2.15	56.54	73.9	17.3	218	288	-
Hori.	2390.000	AV	36.06	28.33	24.34	41.59	2.15	49.29	53.9	4.6	162	75	VBW: 30 Hz
Hori.	4824.000	AV	39.61	31.64	6.46	42.88	2.15	36.98	53.9	16.9	128	239	VBW: 30 Hz
Hori.	7236.000	AV	36.77	37.25	7.89	42.98	2.15	41.08	53.9	12.8	100	0	VBW: 30 Hz
Hori.	9648.000	AV	37.45	38.97	9.18	43.13	2.15	44.62	53.9	9.2	218	288	VBW: 30 Hz
Vert.	2390.000	PK	46.83	28.33	24.34	41.59	2.15	60.06	73.9	13.8	154	90	-
Vert.	4824.000	PK	51.81	31.64	6.46	42.88	2.15	49.18	73.9	24.7	311	358	-
Vert.	7236.000	PK	49.26	37.25	7.89	42.98	2.15	53.57	73.9	20.3	100	0	-
Vert.	9648.000	PK	49.62	38.97	9.18	43.13	2.15	56.79	73.9	17.1	143	80	-
Vert.	2390.000	AV	36.04	28.33	24.34	41.59	2.15	49.27	53.9	4.6	154	90	VBW: 30 Hz
Vert.	4824.000	AV	42.55	31.64	6.46	42.88	2.15	39.92	53.9	13.9	311	358	VBW: 30 Hz
Vert.	7236.000	AV	36.96	37.25	7.89	42.98	2.15	41.27	53.9	12.6	100	0	VBW: 30 Hz
Vert.	9648.000	AV	37.84	38.97	9.18	43.13	2.15	45.01	53.9	8.8	143	80	VBW: 30 Hz

Result = Reading + Ant.Fac. + Loss (Cable+(Attenuator or Filter)(below 18 GHz)) - Gain(Amplifier) + Distance factor

Distance factor : 1 GHz - 13 GHz : 20 log ( 3.84 m / 3.0 m ) = 2.15 dB

13 GHz - 40 GHz : 20log (1.0 m / 3.0 m) = -9.54 dB

### 20 dBc Data Sheet (RBW 100 kHz, VBW 300 kHz)

Polarity	Frequency [MHz]	Detector	Reading [dBuV]	Ant.Fac. [dB/m]	Loss [dB]	Gain [dB]	Distance Factor [dB]	Result [dBuV/m]	Limit [dBuV/m]	Margin [dB]	Remark
Hori.	2412.000	PK	92.13	28.29	24.35	41.60	2.15	105.32	-	-	Carrier
Hori.	2400.000	PK	40.01	28.31	24.34	41.60	2.15	53.21	85.32	32.1	-
Vert.	2412.000	PK	92.00	28.29	24.35	41.60	2.15	105.19	-	-	Carrier
Vert.	2400.000	PK	39.28	28.31	24.34	41.60	2.15	52.48	85.19	32.7	-

Result = Reading + Ant.Fac. + Loss (Cable+(Attenuator or Filter)(below 18 GHz)) - Gain(Amplifier) + Distance factor

Distance factor : 1 GHz - 13 GHz : 20 log ( 3.84 m / 3.0 m ) = 2.15 dB

13 GHz - 40 GHz : 20log (1.0 m / 3.0 m) = -9.54 dB

**UL Japan, Inc.**

**Shonan EMC Lab.**

1-22-3 Megumigaoka, Hiratsuka-shi, Kanagawa-ken, 259-1220 JAPAN

Telephone : +81 463 50 6400

Facsimile : +81 463 50 6401

**Radiated Spurious Emission**  
**(Reference Plot for band-edge)**

Report No. 13004393S-A-R2  
Test place Shonan EMC Lab.  
Semi Anechoic Chamber No.3  
Date September 4, 2019  
Temperature / Humidity 24 deg. C / 54 % RH  
Engineer Kenichi Adachi  
(1 GHz – 2.8 GHz)  
Mode Tx, 11b, high power, 2412 MHz  
EUT Serial No. A-1  
Antenna Chain-0: Dual Monopole Antenna  
Chain-1: Dual Monopole Antenna

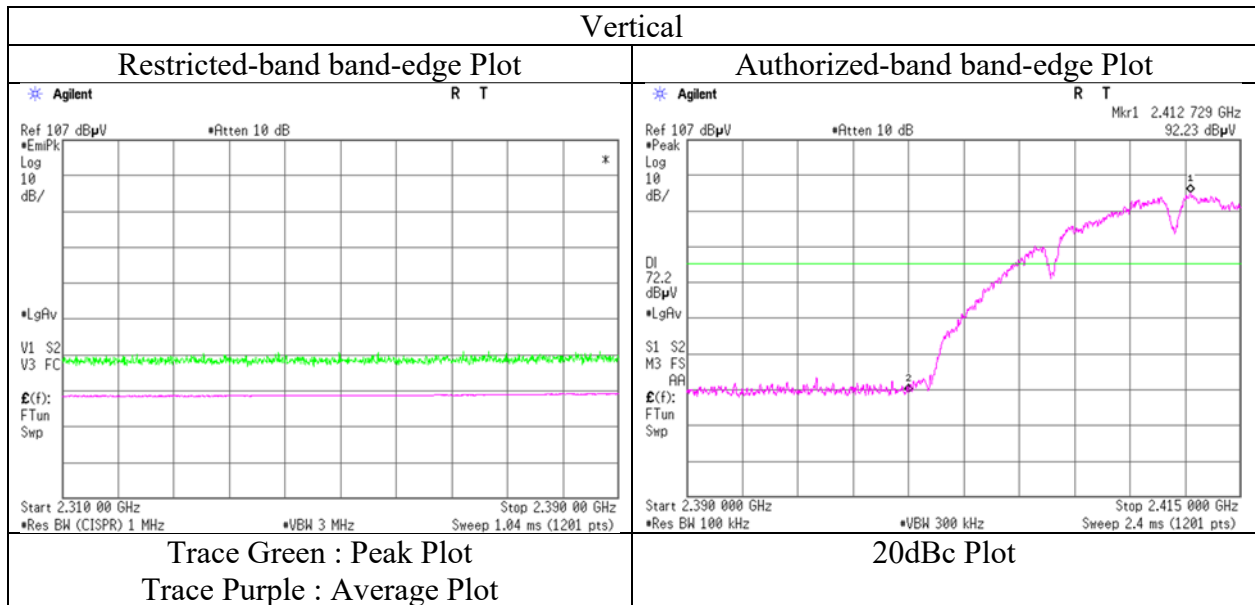
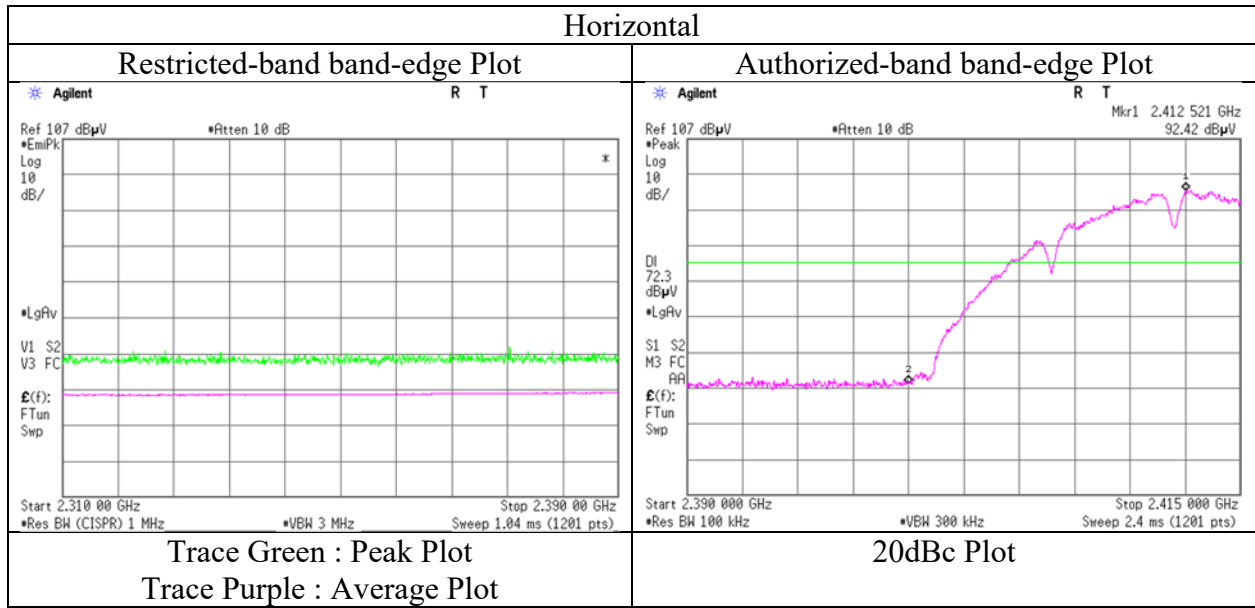

\* The measurement was conducted for a sufficiently long enough time to detect any possible spurious emissions.  
Final result of restricted band edge was shown in tabular data.



## Radiated Spurious Emission

Report No. 13004393S-A-R2  
Test place Shonan EMC Lab.  
Semi Anechoic Chamber No.3 No.3  
Date September 9, 2019 September 13, 2019  
Temperature / Humidity 24 deg.C / 52 %RH 23 deg.C / 52 %RH  
Engineer Kazuya Noda Kazuya Noda  
(1 GHz – 13 GHz) (13 GHz – 26.5 GHz)  
Mode Tx 11b, high power, 2437 MHz  
EUT Serial No. A-1  
Antenna Chain-0: Dual Monopole Antenna  
Chain-1: Dual Monopole Antenna

(\* PK: Peak, AV: Average, QP: Quasi-Peak)

Polarity	Frequency [MHz]	Detector	Reading [dBuV]	Ant.Fac. [dB/m]	Loss [dB]	Gain [dB]	Distance Factor [dB]	Result [dBuV/m]	Limit [dBuV/m]	Margin [dB]	Height [cm]	Angle [deg]	Remark
Hori.	4874.000	PK	50.43	31.70	6.49	42.89	2.15	47.88	73.9	26.0	294	219	-
Hori.	7311.000	PK	48.71	37.36	7.95	43.13	2.15	53.04	73.9	20.8	100	0	-
Hori.	9748.000	PK	49.04	39.31	9.21	43.02	2.15	56.69	73.9	17.2	165	296	-
Hori.	4874.000	AV	39.46	31.70	6.49	42.89	2.15	36.91	53.9	16.9	294	219	VBW: 30 Hz
Hori.	7311.000	AV	36.94	37.36	7.95	43.13	2.15	41.27	53.9	12.6	100	0	VBW: 30 Hz
Hori.	9748.000	AV	37.19	39.31	9.21	43.02	2.15	44.84	53.9	9.0	165	296	VBW: 30 Hz
Vert.	4874.000	PK	50.82	31.70	6.49	42.89	2.15	48.27	73.9	25.6	239	340	-
Vert.	7311.000	PK	48.91	37.36	7.95	43.13	2.15	53.24	73.9	20.6	100	0	-
Vert.	9748.000	PK	49.01	39.31	9.21	43.02	2.15	56.66	73.9	17.2	125	81	-
Vert.	4874.000	AV	39.75	31.70	6.49	42.89	2.15	37.20	53.9	16.7	239	340	VBW: 30 Hz
Vert.	7311.000	AV	37.02	37.36	7.95	43.13	2.15	41.35	53.9	12.5	100	0	VBW: 30 Hz
Vert.	9748.000	AV	37.77	39.31	9.21	43.02	2.15	45.42	53.9	8.4	125	81	VBW: 30 Hz

Result = Reading + Ant.Fac. + Loss (Cable+(Attenuator or Filter)(below 18 GHz)) - Gain(Amplifier) + Distance factor

Distance factor : 1 GHz - 13 GHz :  $20 \log (3.84 \text{ m} / 3.0 \text{ m}) = 2.15 \text{ dB}$

13 GHz - 40 GHz :  $20 \log (1.0 \text{ m} / 3.0 \text{ m}) = -9.54 \text{ dB}$

**UL Japan, Inc.**

**Shonan EMC Lab.**

1-22-3 Megumigaoka, Hiratsuka-shi, Kanagawa-ken, 259-1220 JAPAN

Telephone : +81 463 50 6400

Facsimile : +81 463 50 6401

## Radiated Spurious Emission

Report No.	13004393S-A-R2		
Test place	Shonan EMC Lab.		
Semi Anechoic Chamber	No.3	No.3	No.3
Date	September 8, 2019	September 9, 2019	September 13, 2019
Temperature / Humidity	23 deg.C / 62 %RH	24 deg.C / 52 %RH	23 deg.C / 52 %RH
Engineer	Kenichi Adachi	Kazuya Noda	Kazuya Noda
	(1 GHz – 2.8 GHz)	(2.8 GHz – 13 GHz)	(13 GHz – 26.5 GHz)
Mode	Tx 11b, high power, 2462 MHz		
EUT Serial No.	A-1		
Antenna	Chain-0: Dual Monopole Antenna		
	Chain-1: Dual Monopole Antenna		

(\* PK: Peak, AV: Average, QP: Quasi-Peak)

Polarity	Frequency [MHz]	Detector	Reading [dBuV]	Ant.Fac. [dB/m]	Loss [dB]	Gain [dB]	Distance Factor [dB]	Result [dBuV/m]	Limit [dBuV/m]	Margin [dB]	Height [cm]	Angle [deg]	Remark
Hori.	2483.500	PK	52.33	28.24	14.23	41.62	2.15	55.33	73.9	18.5	146	82	-
Hori.	4924.000	PK	50.38	31.82	6.52	42.90	2.15	47.97	73.9	25.9	310	216	-
Hori.	7386.000	PK	48.75	37.49	8.00	43.28	2.15	53.11	73.9	20.7	100	0	-
Hori.	9848.000	PK	48.79	39.33	9.24	42.92	2.15	56.59	73.9	17.3	205	298	-
Hori.	2483.500	AV	40.11	28.24	14.23	41.62	2.15	43.11	53.9	10.7	146	82	VBW: 30 Hz
Hori.	4924.000	AV	40.02	31.82	6.52	42.90	2.15	37.61	53.9	16.2	310	216	VBW: 30 Hz
Hori.	7386.000	AV	37.18	37.49	8.00	43.28	2.15	41.54	53.9	12.3	100	0	VBW: 30 Hz
Hori.	9848.000	AV	36.90	39.33	9.24	42.92	2.15	44.70	53.9	9.2	205	298	VBW: 30 Hz
Vert.	2483.500	PK	52.31	28.24	14.23	41.62	2.15	55.31	73.9	18.5	154	91	-
Vert.	4924.000	PK	50.74	31.82	6.52	42.90	2.15	48.33	73.9	25.5	241	341	-
Vert.	7386.000	PK	48.66	37.49	8.00	43.28	2.15	53.02	73.9	20.8	100	0	-
Vert.	9848.000	PK	49.53	39.33	9.24	42.92	2.15	57.33	73.9	16.5	128	82	-
Vert.	2483.500	AV	40.09	28.24	14.23	41.62	2.15	43.09	53.9	10.8	154	91	VBW: 30 Hz
Vert.	4924.000	AV	40.21	31.82	6.52	42.90	2.15	37.80	53.9	16.1	241	341	VBW: 30 Hz
Vert.	7386.000	AV	37.16	37.49	8.00	43.28	2.15	41.52	53.9	12.3	100	0	VBW: 30 Hz
Vert.	9848.000	AV	37.61	39.33	9.24	42.92	2.15	45.41	53.9	8.4	128	82	VBW: 30 Hz

Result = Reading + Ant.Fac. + Loss (Cable+(Attenuator or Filter)(below 18 GHz)) - Gain(Amplifier) + Distance factor

Distance factor : 1 GHz - 13 GHz :  $20 \log(3.84 \text{ m} / 3.0 \text{ m}) = 2.15 \text{ dB}$

13 GHz - 40 GHz :  $20 \log(1.0 \text{ m} / 3.0 \text{ m}) = -9.54 \text{ dB}$

**UL Japan, Inc.**

**Shonan EMC Lab.**

1-22-3 Megumigaoka, Hiratsuka-shi, Kanagawa-ken, 259-1220 JAPAN

Telephone : +81 463 50 6400

Facsimile : +81 463 50 6401

**Radiated Spurious Emission**  
**(Reference Plot for band-edge)**

Report No. 13004393S-A-R2  
Test place Shonan EMC Lab.  
Semi Anechoic Chamber No.3  
Date September 8, 2019  
Temperature / Humidity 23 deg.C / 62 %RH  
Engineer Kenichi Adachi  
(1 GHz – 2.8 GHz)  
Mode Tx 11b, high power, 2462 MHz  
EUT Serial No. A-1  
Antenna Chain-0: Dual Monopole Antenna  
Chain-1: Dual Monopole Antenna

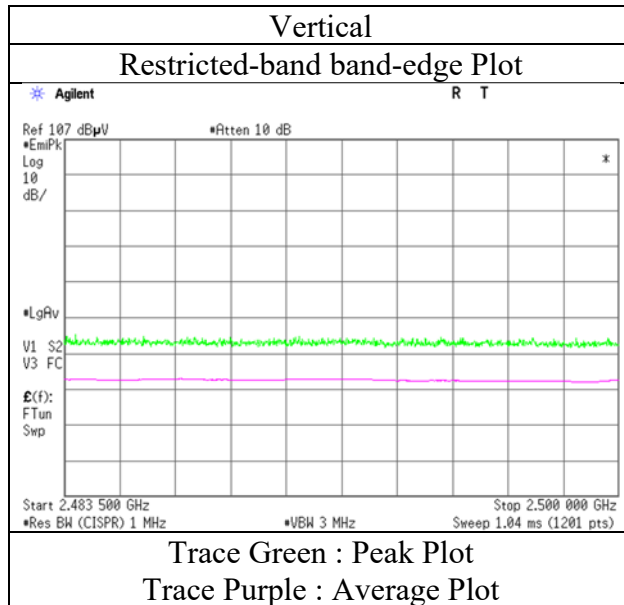
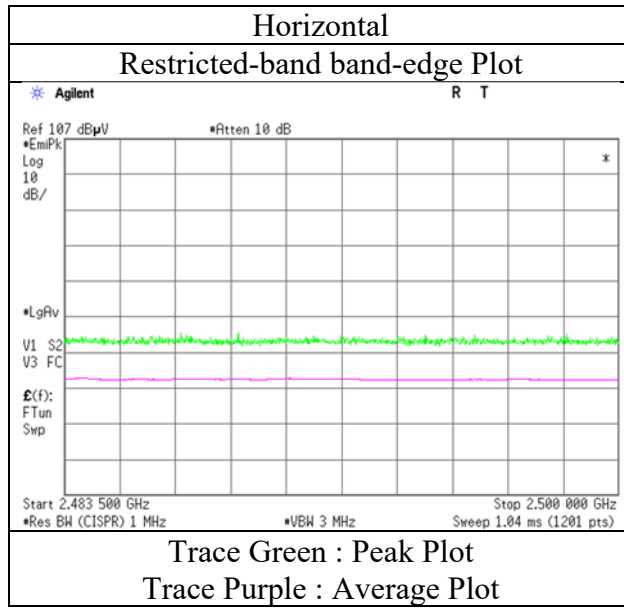

\* The measurement was conducted for a sufficiently long enough time to detect any possible spurious emissions. Final result of restricted band edge was shown in tabular data.

## Radiated Spurious Emission

Report No. 13004393S-A-R2  
Test place Shonan EMC Lab.  
Semi Anechoic Chamber No.3 No.3 No.3 No.3  
Date September 16, 2019 September 8, 2019 September 9, 2019 September 13, 2019  
Temperature / Humidity 23 deg.C / 61 %RH 23 deg.C / 62 %RH 24 deg.C / 52 %RH 23 deg.C / 52 %RH  
Engineer Kenichi Adachi Kenichi Adachi Kazuya Noda Kazuya Noda  
(30 MHz – 1 GHz) (1 GHz – 2.8 GHz) (2.8 GHz – 13 GHz) (13 GHz – 26.5 GHz)  
Mode Tx 11g, high power, 2412 MHz  
EUT Serial No. A-1  
Antenna Chain-0: Dual Monopole Antenna  
Chain-1: Dual Monopole Antenna

(\* PK: Peak, AV: Average, QP: Quasi-Peak)

Polarity	Frequency [MHz]	Detector	Reading [dBuV]	Ant.Fac. [dB/m]	Loss [dB]	Gain [dB]	Distance Factor [dB]	Result [dBuV/m]	Limit [dBuV/m]	Margin [dB]	Height [cm]	Angle [deg]	Remark
Hori.	67.687	QP	31.48	6.69	6.66	32.18	0.00	12.65	40.0	27.3	271	299	-
Hori.	124.651	QP	33.76	13.35	7.35	32.14	0.00	22.32	43.5	21.1	239	238	-
Hori.	161.239	QP	33.89	15.12	7.92	32.11	0.00	24.82	43.5	18.6	192	273	-
Hori.	221.998	QP	36.75	11.02	8.22	32.04	0.00	23.95	46.0	22.0	149	144	-
Hori.	719.994	QP	32.55	19.75	10.44	31.83	0.00	30.91	46.0	15.0	100	99	-
Hori.	891.161	QP	29.24	21.59	10.99	31.14	0.00	30.68	46.0	15.3	100	288	-
Hori.	945.566	QP	30.28	21.57	11.16	30.68	0.00	32.33	46.0	13.6	100	287	-
Hori.	2390.000	PK	58.66	28.33	14.15	41.59	2.15	61.70	73.9	12.2	158	77	-
Hori.	4824.000	PK	50.04	31.64	6.46	42.88	2.15	47.41	73.9	26.4	129	300	-
Hori.	7236.000	PK	48.44	37.25	7.89	42.98	2.15	52.75	73.9	21.1	100	0	-
Hori.	9648.000	PK	49.54	38.97	9.18	43.13	2.15	56.71	73.9	17.1	161	296	-
Hori.	2390.000	AV	44.28	28.33	14.15	41.59	2.15	47.32	53.9	6.5	158	77	VBW: 300 Hz
Hori.	4824.000	AV	38.06	31.64	6.46	42.88	2.15	35.43	53.9	18.4	129	300	VBW: 300 Hz
Hori.	7236.000	AV	37.04	37.25	7.89	42.98	2.15	41.35	53.9	12.5	100	0	VBW: 300 Hz
Hori.	9648.000	AV	38.71	38.97	9.18	43.13	2.15	45.88	53.9	8.0	161	296	VBW: 300 Hz
Vert.	66.033	QP	42.76	6.92	6.56	32.18	0.00	24.06	40.0	15.9	100	206	-
Vert.	107.963	QP	37.09	11.46	7.29	32.15	0.00	23.69	43.5	19.8	100	232	-
Vert.	161.657	QP	37.68	15.13	7.91	32.11	0.00	28.61	43.5	14.8	100	275	-
Vert.	221.998	QP	37.58	11.02	8.22	32.04	0.00	24.78	46.0	21.2	100	108	-
Vert.	701.994	QP	32.44	19.37	10.38	31.86	0.00	30.33	46.0	15.6	100	215	-
Vert.	945.566	QP	25.36	21.57	11.16	30.68	0.00	27.41	46.0	18.5	100	144	-
Vert.	2390.000	PK	59.37	28.33	14.15	41.59	2.15	62.41	73.9	11.4	153	89	-
Vert.	4824.000	PK	50.98	31.64	6.46	42.88	2.15	48.35	73.9	25.5	177	36	-
Vert.	7236.000	PK	48.62	37.25	7.89	42.98	2.15	52.93	73.9	20.9	100	0	-
Vert.	9648.000	PK	50.42	38.97	9.18	43.13	2.15	57.59	73.9	16.3	129	101	-
Vert.	2390.000	AV	44.52	28.33	14.15	41.59	2.15	47.56	53.9	6.3	153	89	VBW: 300 Hz
Vert.	4824.000	AV	39.42	31.64	6.46	42.88	2.15	36.79	53.9	17.1	177	36	VBW: 300 Hz
Vert.	7236.000	AV	37.15	37.25	7.89	42.98	2.15	41.46	53.9	12.4	100	0	VBW: 300 Hz
Vert.	9648.000	AV	40.02	38.97	9.18	43.13	2.15	47.19	53.9	6.7	129	101	VBW: 300 Hz

Result = Reading + Ant.Fac. + Loss (Cable+(Attenuator or Filter)(below 18 GHz)) - Gain(Amplifier) + Distance factor

Distance factor : 1 GHz - 13 GHz :  $20 \log(3.84 \text{ m}/3.0 \text{ m}) = 2.15 \text{ dB}$

13 GHz - 40 GHz :  $20 \log(1.0 \text{ m}/3.0 \text{ m}) = -9.54 \text{ dB}$

**20 dBc Data Sheet (RBW 100 kHz, VBW 300 kHz)**

Polarity	Frequency [MHz]	Detector	Reading [dBuV]	Ant.Fac. [dB/m]	Loss [dB]	Gain [dB]	Distance Factor [dB]	Result [dBuV/m]	Limit [dBuV/m]	Margin [dB]	Remark
Hori.	2412.000	PK	98.96	28.29	14.16	41.60	2.15	101.96	-	-	Carrier
Hori.	2400.000	PK	61.09	28.31	14.15	41.60	2.15	64.10	81.96	17.8	-
Vert.	2412.000	PK	99.27	28.29	14.16	41.60	2.15	102.27	-	-	Carrier
Vert.	2400.000	PK	61.99	28.31	14.15	41.60	2.15	65.00	82.27	17.2	-

Result = Reading + Ant.Fac. + Loss (Cable+(Attenuator or Filter)(below 18 GHz)) - Gain(Amplifier) + Distance factor

Distance factor : 1 GHz - 13 GHz :  $20 \log(3.84 \text{ m}/3.0 \text{ m}) = 2.15 \text{ dB}$

13 GHz - 40 GHz :  $20 \log(1.0 \text{ m}/3.0 \text{ m}) = -9.54 \text{ dB}$

**Radiated Spurious Emission**  
**(Reference Plot for band-edge)**

Report No. 13004393S-A-R2  
Test place Shonan EMC Lab.  
Semi Anechoic Chamber No.3  
Date September 8, 2019  
Temperature / Humidity 23 deg.C / 62 %RH  
Engineer Kenichi Adachi  
(1 GHz – 2.8 GHz)  
Mode Tx 11g, high power, 2412 MHz  
EUT Serial No. A-1  
Antenna Chain-0: Dual Monopole Antenna  
Chain-1: Dual Monopole Antenna

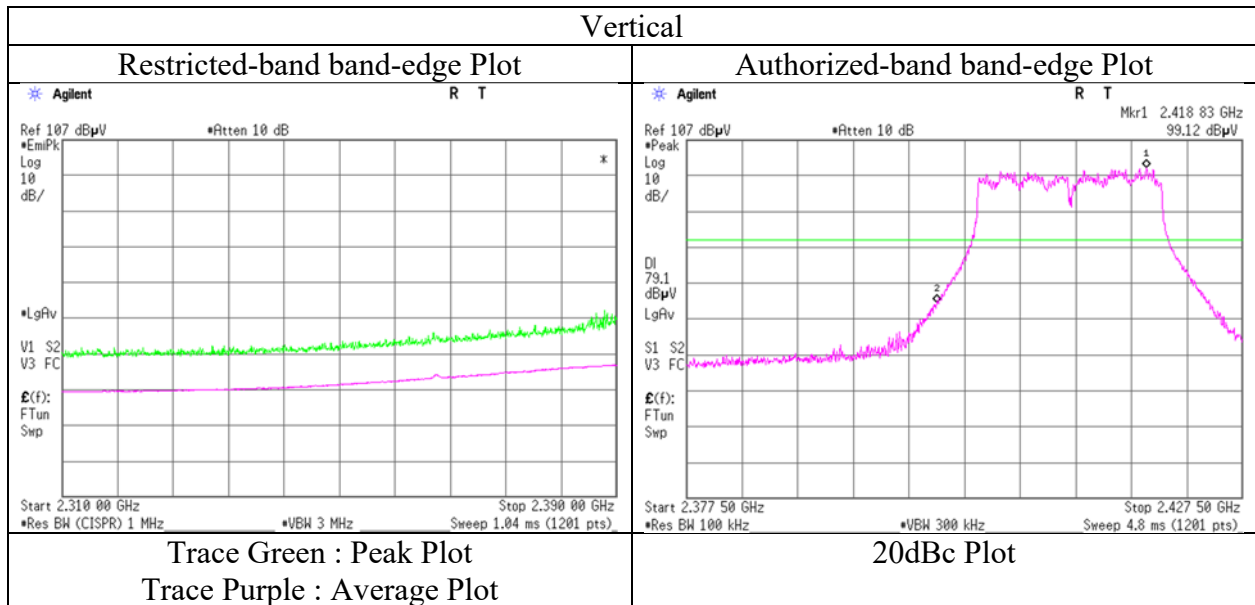
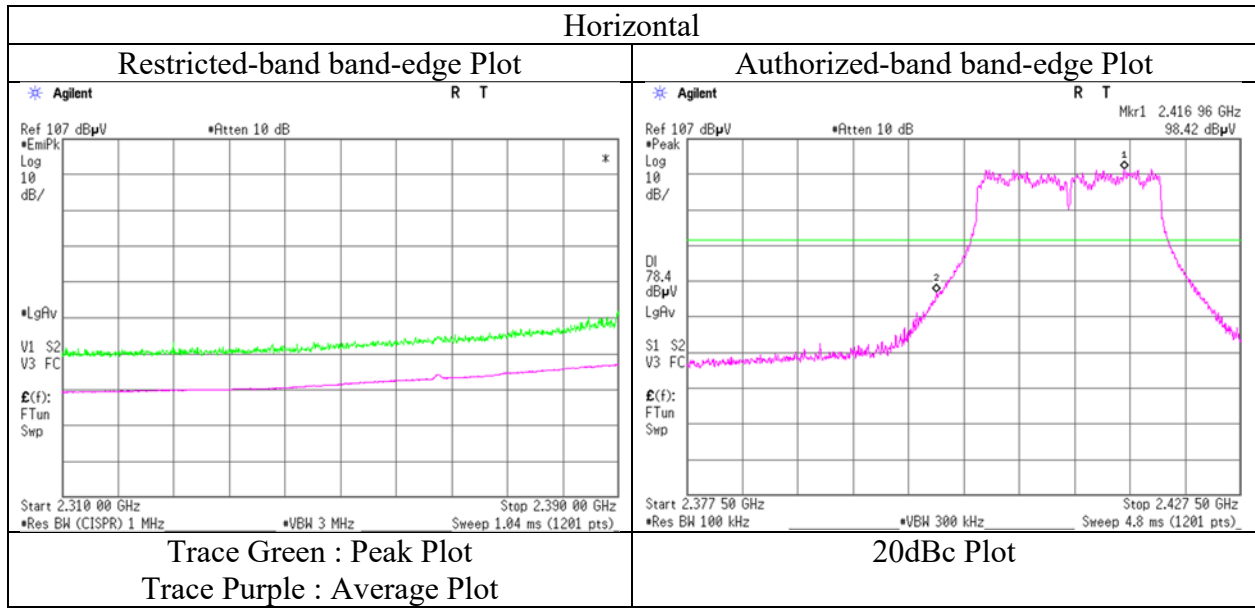

\* The measurement was conducted for a sufficiently long enough time to detect any possible spurious emissions.  
Final result of restricted band edge was shown in tabular data.

## Radiated Spurious Emission

Report No. 13004393S-A-R2  
Test place Shonan EMC Lab.  
Semi Anechoic Chamber No.3 No.3  
Date September 9, 2019 September 13, 2019  
Temperature / Humidity 24 deg.C / 52 %RH 23 deg.C / 52 %RH  
Engineer Kazuya Noda Kazuya Noda  
(1 GHz – 13 GHz) (13 GHz – 26.5 GHz)  
Mode Tx 11g, high power, 2437 MHz  
EUT Serial No. A-1  
Antenna Chain-0: Dual Monopole Antenna  
Chain-1: Dual Monopole Antenna

(\* PK: Peak, AV: Average, QP: Quasi-Peak)

Polarity	Frequency [MHz]	Detector	Reading [dBuV]	Ant.Fac. [dB/m]	Loss [dB]	Gain [dB]	Distance Factor [dB]	Result [dBuV/m]	Limit [dBuV/m]	Margin [dB]	Height [cm]	Angle [deg]	Remark
Hori.	4874.000	PK	49.82	31.70	6.49	42.89	2.15	47.27	73.9	26.6	294	341	-
Hori.	7311.000	PK	48.38	37.36	7.95	43.13	2.15	52.71	73.9	21.1	100	0	-
Hori.	9748.000	PK	48.96	39.31	9.21	43.02	2.15	56.61	73.9	17.2	164	298	-
Hori.	4874.000	AV	37.96	31.70	6.49	42.89	2.15	35.41	53.9	18.4	294	341	VBW: 300 Hz
Hori.	7311.000	AV	37.02	37.36	7.95	43.13	2.15	41.35	53.9	12.5	100	0	VBW: 300 Hz
Hori.	9748.000	AV	37.69	39.31	9.21	43.02	2.15	45.34	53.9	8.5	164	298	VBW: 300 Hz
Vert.	4874.000	PK	50.09	31.70	6.49	42.89	2.15	47.54	73.9	26.3	238	340	-
Vert.	7311.000	PK	48.62	37.36	7.95	43.13	2.15	52.95	73.9	20.9	100	0	-
Vert.	9748.000	PK	50.07	39.31	9.21	43.02	2.15	57.72	73.9	16.1	116	83	-
Vert.	4874.000	AV	38.82	31.70	6.49	42.89	2.15	36.27	53.9	17.6	238	340	VBW: 300 Hz
Vert.	7311.000	AV	37.12	37.36	7.95	43.13	2.15	41.45	53.9	12.4	100	0	VBW: 300 Hz
Vert.	9748.000	AV	38.82	39.31	9.21	43.02	2.15	46.47	53.9	7.4	116	83	VBW: 300 Hz

Result = Reading + Ant.Fac. + Loss (Cable+(Attenuator or Filter)(below 18 GHz)) - Gain(Amplifier) + Distance factor

Distance factor : 1 GHz - 13 GHz :  $20 \log(3.84 \text{ m} / 3.0 \text{ m}) = 2.15 \text{ dB}$

13 GHz - 40 GHz :  $20 \log(1.0 \text{ m} / 3.0 \text{ m}) = -9.54 \text{ dB}$

**UL Japan, Inc.**

**Shonan EMC Lab.**

1-22-3 Megumigaoka, Hiratsuka-shi, Kanagawa-ken, 259-1220 JAPAN

Telephone : +81 463 50 6400

Facsimile : +81 463 50 6401

## Radiated Spurious Emission

Report No.	13004393S-A-R2		
Test place	Shonan EMC Lab.		
Semi Anechoic Chamber	No.3	No.3	No.3
Date	September 9, 2019	September 9, 2019	September 13, 2019
Temperature / Humidity	23 deg.C / 62 %RH	24 deg.C / 52 %RH	23 deg.C / 52 %RH
Engineer	Kenichi Adachi	Kazuya Noda	Kazuya Noda
	(1 GHz – 2.8 GHz)	(2.8 GHz – 13 GHz)	(13 GHz – 26.5 GHz)
Mode	Tx 11g, high power, 2462 MHz		
EUT Serial No.	A-1		
Antenna	Chain-0: Dual Monopole Antenna		
	Chain-1: Dual Monopole Antenna		

(\* PK: Peak, AV: Average, QP: Quasi-Peak)

Polarity	Frequency [MHz]	Detector	Reading [dBuV]	Ant.Fac. [dB/m]	Loss [dB]	Gain [dB]	Distance Factor [dB]	Result [dBuV/m]	Limit [dBuV/m]	Margin [dB]	Height [cm]	Angle [deg]	Remark
Hori.	2483.500	PK	61.70	28.24	14.23	41.62	2.15	64.70	73.9	9.2	138	86	-
Hori.	4924.000	PK	49.91	31.82	6.52	42.90	2.15	47.50	73.9	26.4	137	300	-
Hori.	7386.000	PK	48.43	37.49	8.00	43.28	2.15	52.79	73.9	21.1	100	0	-
Hori.	9848.000	PK	48.79	39.33	9.24	42.92	2.15	56.59	73.9	17.3	100	0	-
Hori.	2483.500	AV	45.55	28.24	14.23	41.62	2.15	48.55	53.9	5.3	138	86	VBW: 300 Hz
Hori.	4924.000	AV	38.21	31.82	6.52	42.90	2.15	35.80	53.9	18.1	137	300	VBW: 300 Hz
Hori.	7386.000	AV	37.31	37.49	8.00	43.28	2.15	41.67	53.9	12.2	100	0	VBW: 300 Hz
Hori.	9848.000	AV	37.18	39.33	9.24	42.92	2.15	44.98	53.9	8.9	100	0	VBW: 300 Hz
Vert.	2483.500	PK	61.62	28.24	14.23	41.62	2.15	64.62	73.9	9.2	144	97	-
Vert.	4924.000	PK	50.53	31.82	6.52	42.90	2.15	48.12	73.9	25.7	210	341	-
Vert.	7386.000	PK	48.21	37.49	8.00	43.28	2.15	52.57	73.9	21.3	100	0	-
Vert.	9848.000	PK	49.01	39.33	9.24	42.92	2.15	56.81	73.9	17.0	128	82	-
Vert.	2483.500	AV	46.71	28.24	14.23	41.62	2.15	49.71	53.9	4.1	144	97	VBW: 300 Hz
Vert.	4924.000	AV	39.38	31.82	6.52	42.90	2.15	36.97	53.9	16.9	210	341	VBW: 300 Hz
Vert.	7386.000	AV	37.14	37.49	8.00	43.28	2.15	41.50	53.9	12.4	100	0	VBW: 300 Hz
Vert.	9848.000	AV	38.18	39.33	9.24	42.92	2.15	45.98	53.9	7.9	128	82	VBW: 300 Hz

Result = Reading + Ant.Fac. + Loss (Cable+(Attenuator or Filter)(below 18 GHz)) - Gain(Amplifier) + Distance factor

Distance factor : 1 GHz - 13 GHz :  $20 \log(3.84 \text{ m} / 3.0 \text{ m}) = 2.15 \text{ dB}$

13 GHz - 40 GHz :  $20 \log(1.0 \text{ m} / 3.0 \text{ m}) = -9.54 \text{ dB}$

**UL Japan, Inc.**

**Shonan EMC Lab.**

1-22-3 Megumigaoka, Hiratsuka-shi, Kanagawa-ken, 259-1220 JAPAN

Telephone : +81 463 50 6400

Facsimile : +81 463 50 6401

**Radiated Spurious Emission**  
**(Reference Plot for band-edge)**

Report No.	13004393S-A-R2
Test place	Shonan EMC Lab.
Semi Anechoic Chamber	No.3
Date	September 9, 2019
Temperature / Humidity	23 deg.C / 62 %RH
Engineer	Kenichi Adachi
	(1 GHz – 2.8 GHz)
Mode	Tx 11g, high power, 2462 MHz
EUT Serial No.	A-1
Antenna	Chain-0: Dual Monopole Antenna
	Chain-1: Dual Monopole Antenna

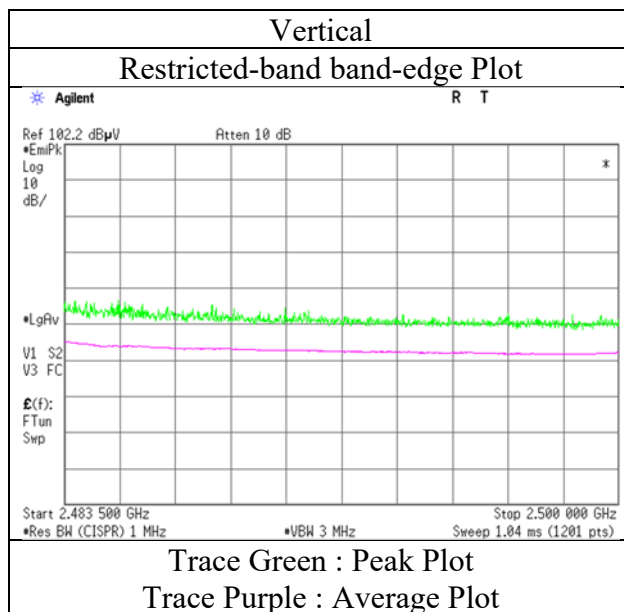
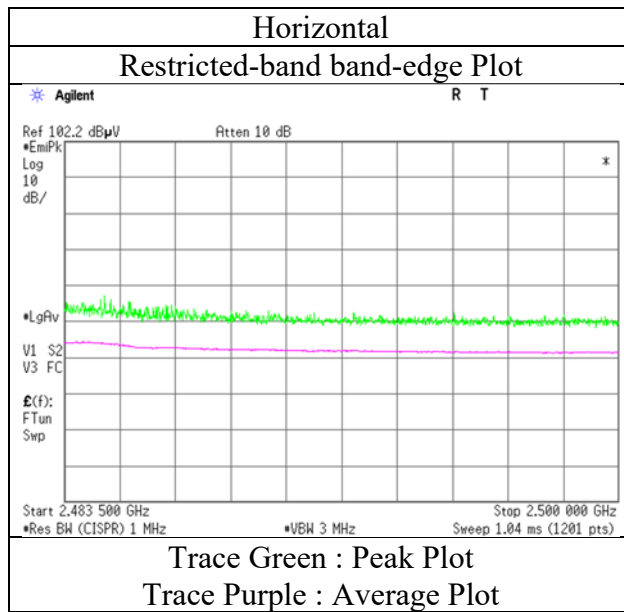

\* The measurement was conducted for a sufficiently long enough time to detect any possible spurious emissions. Final result of restricted band edge was shown in tabular data.



## Radiated Spurious Emission

Report No.	13004393S-A-R2		
Test place	Shonan EMC Lab.		
Semi Anechoic Chamber	No.3	No.3	No.3
Date	September 9, 2019	September 9, 2019	September 13, 2019
Temperature / Humidity	23 deg.C / 62 %RH	24 deg.C / 52 %RH	23 deg.C / 52 %RH
Engineer	Kenichi Adachi	Kazuya Noda	Kazuya Noda
	(1 GHz – 2.8 GHz)	(2.8 GHz – 13 GHz)	(13 GHz – 26.5 GHz)
Mode	Tx, 11n-20 CDD, high power, 2412 MHz		
EUT Serial No.	A-1		
Antenna	Chain-0: Dual Monopole Antenna		
	Chain-1: Dual Monopole Antenna		

(\* PK: Peak, AV: Average, QP: Quasi-Peak)

Polarity	Frequency [MHz]	Detector	Reading [dBuV]	Ant.Fac. [dB/m]	Loss [dB]	Gain [dB]	Distance Factor [dB]	Result [dBuV/m]	Limit [dBuV/m]	Margin [dB]	Height [cm]	Angle [deg]	Remark
Hori.	2390.000	PK	58.18	28.33	14.15	41.59	2.15	61.22	73.9	12.6	134	94	-
Hori.	4824.000	PK	50.09	31.64	6.46	42.88	2.15	47.46	73.9	26.4	128	308	-
Hori.	7236.000	PK	48.55	37.25	7.89	42.98	2.15	52.86	73.9	21.0	100	0	-
Hori.	9648.000	PK	49.82	38.97	9.18	43.13	2.15	56.99	73.9	16.9	163	296	-
Hori.	2390.000	AV	42.90	28.33	14.15	41.59	2.15	45.94	53.9	7.9	134	94	VBW: 510 Hz
Hori.	4824.000	AV	38.17	31.64	6.46	42.88	2.15	35.54	53.9	18.3	128	308	VBW: 510 Hz
Hori.	7236.000	AV	37.03	37.25	7.89	42.98	2.15	41.34	53.9	12.5	100	0	VBW: 510 Hz
Hori.	9648.000	AV	38.78	38.97	9.18	43.13	2.15	45.95	53.9	7.9	163	296	VBW: 510 Hz
Vert.	2390.000	PK	58.52	28.33	14.15	41.59	2.15	61.56	73.9	12.3	139	102	-
Vert.	4824.000	PK	50.24	31.64	6.46	42.88	2.15	47.61	73.9	26.2	179	34	-
Vert.	7236.000	PK	48.43	37.25	7.89	42.98	2.15	52.74	73.9	21.1	100	0	-
Vert.	9648.000	PK	50.83	38.97	9.18	43.13	2.15	58.00	73.9	15.9	126	101	-
Vert.	2390.000	AV	43.04	28.33	14.15	41.59	2.15	46.08	53.9	7.8	139	102	VBW: 510 Hz
Vert.	4824.000	AV	39.34	31.64	6.46	42.88	2.15	36.71	53.9	17.1	179	34	VBW: 510 Hz
Vert.	7236.000	AV	37.21	37.25	7.89	42.98	2.15	41.52	53.9	12.3	100	0	VBW: 510 Hz
Vert.	9648.000	AV	39.81	38.97	9.18	43.13	2.15	46.98	53.9	6.9	126	101	VBW: 510 Hz

Result = Reading + Ant.Fac. + Loss (Cable+(Attenuator or Filter)(below 18 GHz)) - Gain(Amplifier) + Distance factor

Distance factor : 1 GHz - 13 GHz : 20 log ( 3.84 m / 3.0 m ) = 2.15 dB

13 GHz - 40 GHz : 20log (1.0 m / 3.0 m) = -9.54 dB

### 20 dBc Data Sheet (RBW 100 kHz, VBW 300 kHz)

Polarity	Frequency [MHz]	Detector	Reading [dBuV]	Ant.Fac. [dB/m]	Loss [dB]	Gain [dB]	Distance Factor [dB]	Result [dBuV/m]	Limit [dBuV/m]	Margin [dB]	Remark
Hori.	2412.000	PK	96.70	28.29	14.16	41.60	2.15	99.70	-	-	Carrier
Hori.	2400.000	PK	64.19	28.31	14.15	41.60	2.15	67.20	79.70	12.5	-
Vert.	2412.000	PK	97.16	28.29	14.16	41.60	2.15	100.16	-	-	Carrier
Vert.	2400.000	PK	62.84	28.31	14.15	41.60	2.15	65.85	80.16	14.3	-

Result = Reading + Ant.Fac. + Loss (Cable+(Attenuator or Filter)(below 18 GHz)) - Gain(Amplifier) + Distance factor

Distance factor : 1 GHz - 13 GHz : 20 log ( 3.84 m / 3.0 m ) = 2.15 dB

13 GHz - 40 GHz : 20log (1.0 m / 3.0 m) = -9.54 dB

**UL Japan, Inc.**

**Shonan EMC Lab.**

1-22-3 Megumigaoka, Hiratsuka-shi, Kanagawa-ken, 259-1220 JAPAN

Telephone : +81 463 50 6400

Facsimile : +81 463 50 6401

**Radiated Spurious Emission**  
**(Reference Plot for band-edge)**

Report No. 13004393S-A-R2  
Test place Shonan EMC Lab.  
Semi Anechoic Chamber No.3  
Date September 9, 2019  
Temperature / Humidity 24 deg. C / 54 % RH  
Engineer Kenichi Adachi  
(1 GHz – 2.8 GHz)  
Mode Tx, 11n-20 CDD, high power, 2412 MHz  
EUT Serial No. A-1  
Antenna Chain-0: Dual Monopole Antenna  
Chain-1: Dual Monopole Antenna

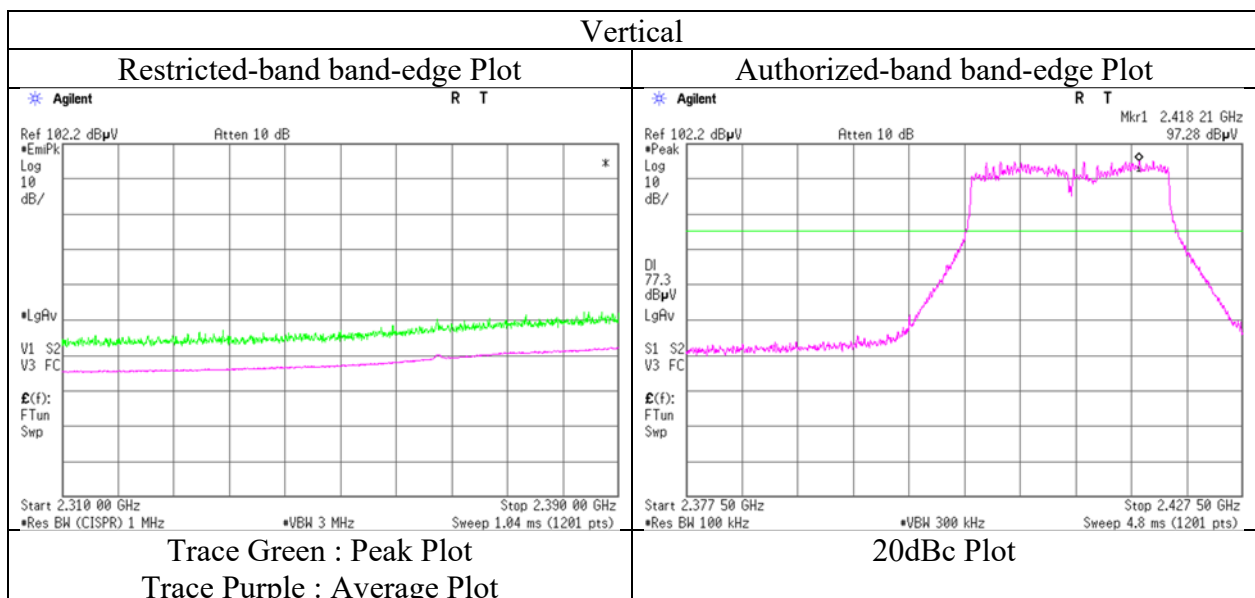
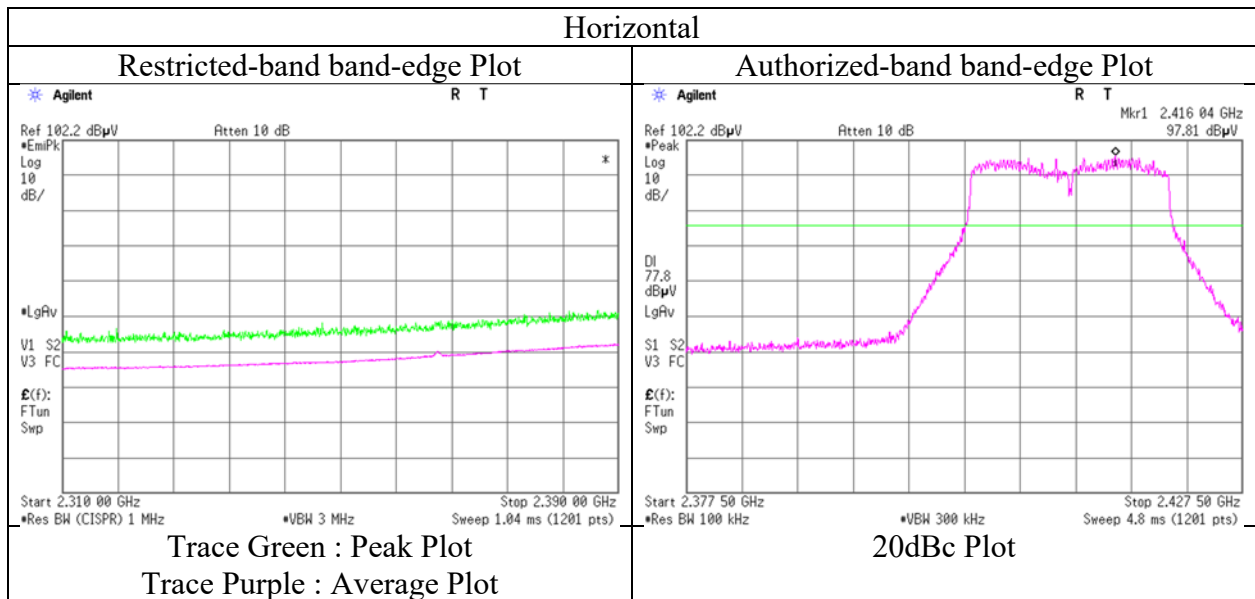

\* The measurement was conducted for a sufficiently long enough time to detect any possible spurious emissions. Final result of restricted band edge was shown in tabular data.

## Radiated Spurious Emission

Report No. 13004393S-A-R2  
Test place Shonan EMC Lab.  
Semi Anechoic Chamber No.3 No.3  
Date September 9, 2019 September 13, 2019  
Temperature / Humidity 24 deg.C / 52 %RH 23 deg.C / 52 %RH  
Engineer Kazuya Noda Kazuya Noda  
(1 GHz – 13 GHz) (13 GHz – 26.5 GHz)  
Mode Tx 11n-20 CDD, high power 2437 MHz  
EUT Serial No. A-1  
Antenna Chain-0: Dual Monopole Antenna  
Chain-1: Dual Monopole Antenna

(\* PK: Peak, AV: Average, QP: Quasi-Peak)

Polarity	Frequency [MHz]	Detector	Reading [dBuV]	Ant.Fac. [dB/m]	Loss [dB]	Gain [dB]	Distance Factor [dB]	Result [dBuV/m]	Limit [dBuV/m]	Margin [dB]	Height [cm]	Angle [deg]	Remark
Hori.	4874.000	PK	49.42	31.70	6.49	42.89	2.15	46.87	73.9	27.0	126	240	-
Hori.	7311.000	PK	48.63	37.36	7.95	43.13	2.15	52.96	73.9	20.9	100	0	-
Hori.	9748.000	PK	49.09	39.31	9.21	43.02	2.15	56.74	73.9	17.1	164	297	-
Hori.	4874.000	AV	37.95	31.70	6.49	42.89	2.15	35.40	53.9	18.5	126	240	VBW: 510 Hz
Hori.	7311.000	AV	37.01	37.36	7.95	43.13	2.15	41.34	53.9	12.5	100	0	VBW: 510 Hz
Hori.	9748.000	AV	37.70	39.31	9.21	43.02	2.15	45.35	53.9	8.5	164	297	VBW: 510 Hz
Vert.	4874.000	PK	49.64	31.70	6.49	42.89	2.15	47.09	73.9	26.8	137	33	-
Vert.	7311.000	PK	48.43	37.36	7.95	43.13	2.15	52.76	73.9	21.1	100	0	-
Vert.	9748.000	PK	49.87	39.31	9.21	43.02	2.15	57.52	73.9	16.3	108	91	-
Vert.	4874.000	AV	38.57	31.70	6.49	42.89	2.15	36.02	53.9	17.8	137	33	VBW: 510 Hz
Vert.	7311.000	AV	37.07	37.36	7.95	43.13	2.15	41.40	53.9	12.5	100	0	VBW: 510 Hz
Vert.	9748.000	AV	38.94	39.31	9.21	43.02	2.15	46.59	53.9	7.3	108	91	VBW: 510 Hz

Result = Reading + Ant.Fac. + Loss (Cable+(Attenuator or Filter)(below 18 GHz)) - Gain(Amplifier) + Distance factor

Distance factor : 1 GHz - 13 GHz :  $20 \log(3.84 \text{ m} / 3.0 \text{ m}) = 2.15 \text{ dB}$

13 GHz - 40 GHz :  $20 \log(1.0 \text{ m} / 3.0 \text{ m}) = -9.54 \text{ dB}$

**UL Japan, Inc.**

**Shonan EMC Lab.**

1-22-3 Megumigaoka, Hiratsuka-shi, Kanagawa-ken, 259-1220 JAPAN

Telephone : +81 463 50 6400

Facsimile : +81 463 50 6401

## Radiated Spurious Emission

Report No.	13004393S-A-R2		
Test place	Shonan EMC Lab.		
Semi Anechoic Chamber	No.3	No.3	No.3
Date	September 9, 2019	September 9, 2019	September 13, 2019
Temperature / Humidity	23 deg.C / 62 %RH	24 deg.C / 52 %RH	23 deg.C / 52 %RH
Engineer	Kenichi Adachi	Kazuya Noda	Kazuya Noda
	(1 GHz – 2.8 GHz)	(2.8 GHz – 13 GHz)	(13 GHz – 26.5 GHz)
Mode	Tx 11n-20 CDD, high power 2462 MHz		
EUT Serial No.	A-1		
Antenna	Chain-0: Dual Monopole Antenna		
	Chain-1: Dual Monopole Antenna		

(\* PK: Peak, AV: Average, QP: Quasi-Peak)

Polarity	Frequency [MHz]	Detector	Reading [dBuV]	Ant.Fac. [dB/m]	Loss [dB]	Gain [dB]	Distance Factor [dB]	Result [dBuV/m]	Limit [dBuV/m]	Margin [dB]	Height [cm]	Angle [deg]	Remark
Hori.	2483.500	PK	63.29	28.24	14.23	41.62	2.15	66.29	73.9	7.6	159	80	-
Hori.	4924.000	PK	49.51	31.82	6.52	42.90	2.15	47.10	73.9	26.8	251	338	-
Hori.	7386.000	PK	48.91	37.49	8.00	43.28	2.15	53.27	73.9	20.6	100	0	-
Hori.	9848.000	PK	48.88	39.33	9.24	42.92	2.15	56.68	73.9	17.2	400	301	-
Hori.	2483.500	AV	46.07	28.24	14.23	41.62	2.15	49.07	53.9	4.8	159	80	VBW: 510 Hz
Hori.	4924.000	AV	38.44	31.82	6.52	42.90	2.15	36.03	53.9	17.8	251	338	VBW: 510 Hz
Hori.	7386.000	AV	37.28	37.49	8.00	43.28	2.15	41.64	53.9	12.2	100	0	VBW: 510 Hz
Hori.	9848.000	AV	37.20	39.33	9.24	42.92	2.15	45.00	53.9	8.9	400	301	VBW: 510 Hz
Vert.	2483.500	PK	65.84	28.24	14.23	41.62	2.15	68.84	73.9	5.0	121	91	-
Vert.	4924.000	PK	50.28	31.82	6.52	42.90	2.15	47.87	73.9	26.0	259	340	-
Vert.	7386.000	PK	49.25	37.49	8.00	43.28	2.15	53.61	73.9	20.2	100	0	-
Vert.	9848.000	PK	49.62	39.33	9.24	42.92	2.15	57.42	73.9	16.4	108	82	-
Vert.	2483.500	AV	47.22	28.24	14.23	41.62	2.15	50.22	53.9	3.6	121	91	VBW: 510 Hz
Vert.	4924.000	AV	38.68	31.82	6.52	42.90	2.15	36.27	53.9	17.6	259	340	VBW: 510 Hz
Vert.	7386.000	AV	37.78	37.49	8.00	43.28	2.15	42.14	53.9	11.7	100	0	VBW: 510 Hz
Vert.	9848.000	AV	38.06	39.33	9.24	42.92	2.15	45.86	53.9	8.0	108	82	VBW: 510 Hz

Result = Reading + Ant.Fac. + Loss (Cable+(Attenuator or Filter)(below 18 GHz)) - Gain(Amplifier) + Distance factor

Distance factor : 1 GHz - 13 GHz :  $20 \log (3.84 \text{ m} / 3.0 \text{ m}) = 2.15 \text{ dB}$

13 GHz - 40 GHz :  $20 \log (1.0 \text{ m} / 3.0 \text{ m}) = -9.54 \text{ dB}$

**UL Japan, Inc.**

**Shonan EMC Lab.**

1-22-3 Megumigaoka, Hiratsuka-shi, Kanagawa-ken, 259-1220 JAPAN

Telephone : +81 463 50 6400

Facsimile : +81 463 50 6401

**Radiated Spurious Emission**  
**(Reference Plot for band-edge)**

Report No. 13004393S-A-R2  
Test place Shonan EMC Lab.  
Semi Anechoic Chamber No.3  
Date September 8, 2019  
Temperature / Humidity 23 deg.C / 62 %RH  
Engineer Kenichi Adachi  
(1 GHz – 2.8 GHz)  
Mode Tx 11n-20 CDD, high power, 2462 MHz  
EUT Serial No. A-1  
Antenna Chain-0: Dual Monopole Antenna  
Chain-1: Dual Monopole Antenna

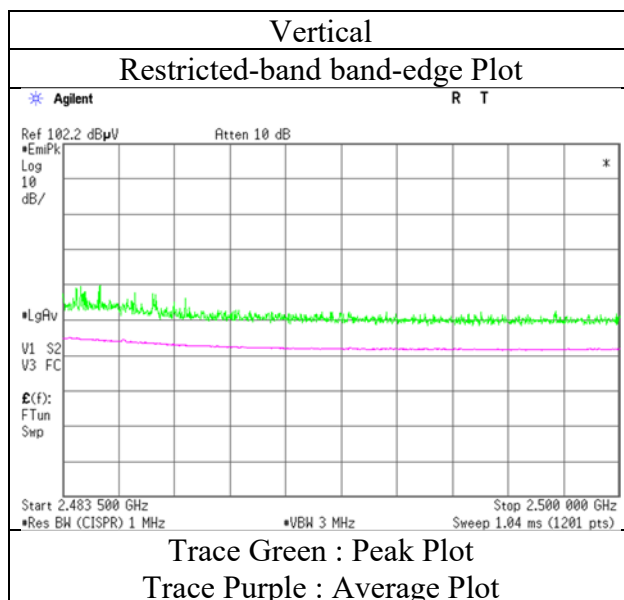
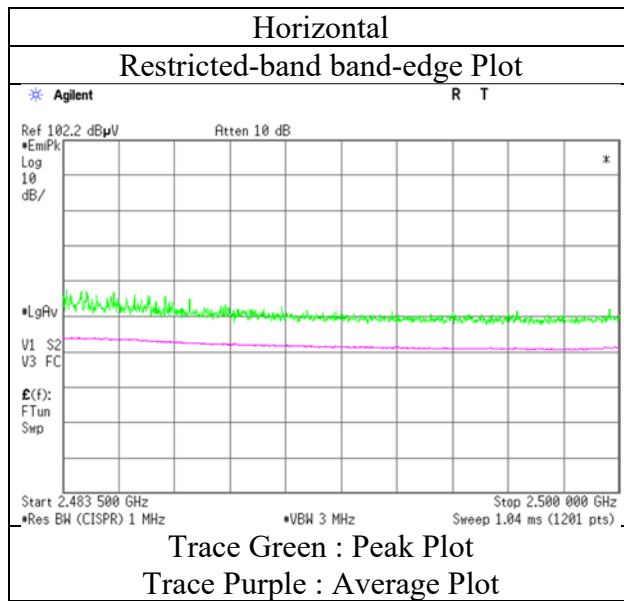

\* The measurement was conducted for a sufficiently long enough time to detect any possible spurious emissions. Final result of restricted band edge was shown in tabular data.

## Radiated Spurious Emission

Report No.	13004393S-A-R2		
Test place	Shonan EMC Lab.		
Semi Anechoic Chamber	No.3	No.3	No.3
Date	September 4, 2019	September 9, 2019	September 13, 2019
Temperature / Humidity	24 deg. C / 54 % RH	24 deg.C / 52 %RH	23 deg.C / 52 %RH
Engineer	Kenichi Adachi	Kazuya Noda	Kazuya Noda
Mode	Tx 11n-20 MIMO, high power, 2412 MHz		
EUT Serial No.	A-1		
Antenna	Chain-0: Dual Monopole Antenna		
	Chain-1: Dual Monopole Antenna		

(\* PK: Peak, AV: Average, QP: Quasi-Peak)

Polarity	Frequency [MHz]	Detector	Reading [dBuV]	Ant.Fac. [dB/m]	Loss [dB]	Gain [dB]	Distance Factor [dB]	Result [dBuV/m]	Limit [dBuV/m]	Margin [dB]	Height [cm]	Angle [deg]	Remark
Hori.	2390.000	PK	68.12	28.33	14.15	41.59	2.15	71.16	73.9	2.7	160	76	-
Hori.	4824.000	PK	49.43	31.64	6.46	42.88	2.15	46.80	73.9	27.1	181	298	-
Hori.	7236.000	PK	49.27	37.25	7.89	42.98	2.15	53.58	73.9	20.3	100	0	-
Hori.	9648.000	PK	50.16	38.97	9.18	43.13	2.15	57.33	73.9	16.5	114	297	-
Hori.	2390.000	AV	43.68	28.33	14.15	41.59	2.15	46.72	53.9	7.1	160	76	VBW: 1 kHz
Hori.	4824.000	AV	38.48	31.64	6.46	42.88	2.15	35.85	53.9	18.0	181	298	VBW: 1 kHz
Hori.	7236.000	AV	37.23	37.25	7.89	42.98	2.15	41.54	53.9	12.3	100	0	VBW: 1 kHz
Hori.	9648.000	AV	39.12	38.97	9.18	43.13	2.15	46.29	53.9	7.6	114	297	VBW: 1 kHz
Vert.	2390.000	PK	68.89	28.33	14.15	41.59	2.15	71.93	73.9	1.9	154	89	-
Vert.	4824.000	PK	50.68	31.64	6.46	42.88	2.15	48.05	73.9	25.8	180	34	-
Vert.	7236.000	PK	48.15	37.25	7.89	42.98	2.15	52.46	73.9	21.4	100	0	-
Vert.	9648.000	PK	50.30	38.97	9.18	43.13	2.15	57.47	73.9	16.4	100	0	-
Vert.	2390.000	AV	44.80	28.33	14.15	41.59	2.15	47.84	53.9	6.0	154	89	VBW: 1 kHz
Vert.	4824.000	AV	39.66	31.64	6.46	42.88	2.15	37.03	53.9	16.8	180	34	VBW: 1 kHz
Vert.	7236.000	AV	37.24	37.25	7.89	42.98	2.15	41.55	53.9	12.3	100	0	VBW: 1 kHz
Vert.	9648.000	AV	40.12	38.97	9.18	43.13	2.15	47.29	53.9	6.6	100	0	VBW: 1 kHz

Result = Reading + Ant.Fac. + Loss (Cable+(Attenuator or Filter)(below 18 GHz)) - Gain(Amplifier) + Distance factor

Distance factor : 1 GHz - 13 GHz :  $20 \log (3.84 \text{ m} / 3.0 \text{ m}) = 2.15 \text{ dB}$

13 GHz - 40 GHz :  $20 \log (1.0 \text{ m} / 3.0 \text{ m}) = -9.54 \text{ dB}$

### 20 dBc Data Sheet (RBW 100 kHz, VBW 300 kHz)

Polarity	Frequency [MHz]	Detector	Reading [dBuV]	Ant.Fac. [dB/m]	Loss [dB]	Gain [dB]	Distance Factor [dB]	Result [dBuV/m]	Limit [dBuV/m]	Margin [dB]	Remark
Hori.	2412.000	PK	98.66	28.29	14.16	41.60	2.15	101.66	-	-	Carrier
Hori.	2400.000	PK	62.40	28.31	14.15	41.60	2.15	65.41	81.66	16.2	-
Vert.	2412.000	PK	99.06	28.29	14.16	41.60	2.15	102.06	-	-	Carrier
Vert.	2400.000	PK	62.54	28.31	14.15	41.60	2.15	65.55	82.06	16.5	-

Result = Reading + Ant.Fac. + Loss (Cable+(Attenuator or Filter)(below 18 GHz)) - Gain(Amplifier) + Distance factor

Distance factor : 1 GHz - 13 GHz :  $20 \log (3.84 \text{ m} / 3.0 \text{ m}) = 2.15 \text{ dB}$

13 GHz - 40 GHz :  $20 \log (1.0 \text{ m} / 3.0 \text{ m}) = -9.54 \text{ dB}$

**Radiated Spurious Emission**  
**(Reference Plot for band-edge)**

Report No. 13004393S-A-R2  
Test place Shonan EMC Lab.  
Semi Anechoic Chamber No.3  
Date September 4, 2019  
Temperature / Humidity 24 deg. C / 54 % RH  
Engineer Kenichi Adachi  
(1 GHz – 2.8 GHz)  
Mode Tx 11n-20 MIMO, high power, 2412 MHz  
EUT Serial No. A-1  
Antenna Chain-0: Dual Monopole Antenna  
Chain-1: Dual Monopole Antenna

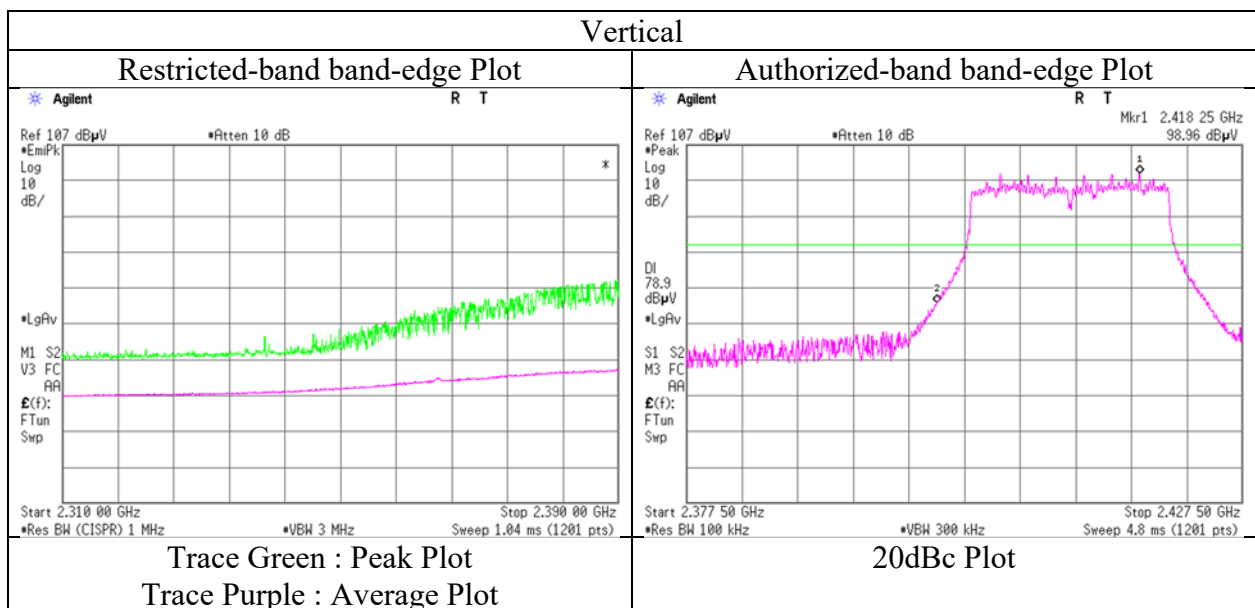
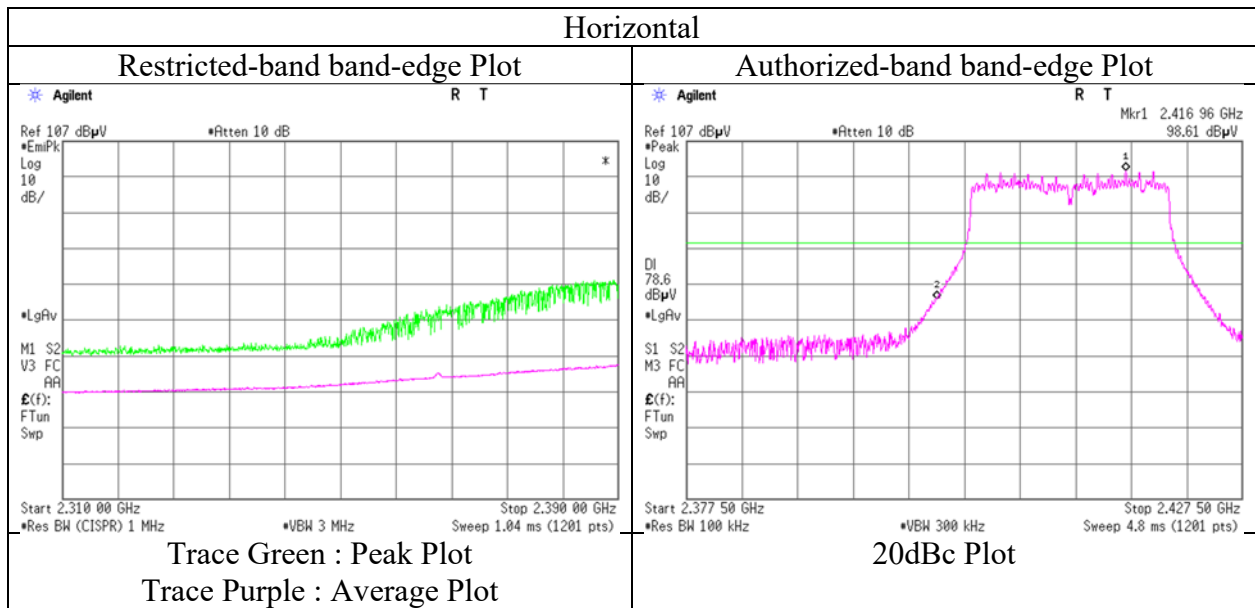

\* The measurement was conducted for a sufficiently long enough time to detect any possible spurious emissions. Final result of restricted band edge was shown in tabular data.

## Radiated Spurious Emission

Report No. 13004393S-A-R2  
Test place Shonan EMC Lab.  
Semi Anechoic Chamber No.3 No.3  
Date September 9, 2019 September 13, 2019  
Temperature / Humidity 24 deg.C / 52 %RH 23 deg.C / 52 %RH  
Engineer Kazuya Noda Kazuya Noda  
(1 GHz – 13 GHz) (13 GHz – 26.5 GHz)  
Mode Tx 11n-20 MIMO, high power, 2437 MHz  
EUT Serial No. A-1  
Antenna Chain-0: Dual Monopole Antenna  
Chain-1: Dual Monopole Antenna

(\* PK: Peak, AV: Average, QP: Quasi-Peak)

Polarity	Frequency [MHz]	Detector	Reading [dBuV]	Ant.Fac. [dB/m]	Loss [dB]	Gain [dB]	Distance Factor [dB]	Result [dBuV/m]	Limit [dBuV/m]	Margin [dB]	Height [cm]	Angle [deg]	Remark
Hori.	4874.000	PK	48.69	31.70	6.49	42.89	2.15	46.14	73.9	27.7	161	299	-
Hori.	7311.000	PK	47.95	37.36	7.95	43.13	2.15	52.28	73.9	21.6	100	0	-
Hori.	9748.000	PK	48.64	39.31	9.21	43.02	2.15	56.29	73.9	17.6	143	301	-
Hori.	4874.000	AV	37.96	31.70	6.49	42.89	2.15	35.41	53.9	18.4	161	299	VBW: 1 kHz
Hori.	7311.000	AV	37.15	37.36	7.95	43.13	2.15	41.48	53.9	12.4	100	0	VBW: 1 kHz
Hori.	9748.000	AV	37.98	39.31	9.21	43.02	2.15	45.63	53.9	8.2	143	301	VBW: 1 kHz
Vert.	4874.000	PK	50.92	31.70	6.49	42.89	2.15	48.37	73.9	25.5	284	182	-
Vert.	7311.000	PK	48.02	37.36	7.95	43.13	2.15	52.35	73.9	21.5	100	0	-
Vert.	9748.000	PK	49.38	39.31	9.21	43.02	2.15	57.03	73.9	16.8	108	91	-
Vert.	4874.000	AV	40.53	31.70	6.49	42.89	2.15	37.98	53.9	15.9	284	182	VBW: 1 kHz
Vert.	7311.000	AV	37.25	37.36	7.95	43.13	2.15	41.58	53.9	12.3	100	0	VBW: 1 kHz
Vert.	9748.000	AV	39.02	39.31	9.21	43.02	2.15	46.67	53.9	7.2	108	91	VBW: 1 kHz

Result = Reading + Ant.Fac. + Loss (Cable+(Attenuator or Filter)(below 18 GHz)) - Gain(Amplifier) + Distance factor

Distance factor : 1 GHz - 13 GHz :  $20 \log(3.84 \text{ m} / 3.0 \text{ m}) = 2.15 \text{ dB}$

13 GHz - 40 GHz :  $20 \log(1.0 \text{ m} / 3.0 \text{ m}) = -9.54 \text{ dB}$

**UL Japan, Inc.**

**Shonan EMC Lab.**

1-22-3 Megumigaoka, Hiratsuka-shi, Kanagawa-ken, 259-1220 JAPAN

Telephone : +81 463 50 6400

Facsimile : +81 463 50 6401



## Radiated Spurious Emission

Report No.	13004393S-A-R2		
Test place	Shonan EMC Lab.		
Semi Anechoic Chamber	No.3	No.3	No.3
Date	September 4, 2019	September 9, 2019	September 13, 2019
Temperature / Humidity	24 deg. C / 54 % RH	24 deg.C / 52 %RH	23 deg.C / 52 %RH
Engineer	Kenichi Adachi	Kazuya Noda	Kazuya Noda
	(1 GHz – 2.8 GHz)	(2.8 GHz – 13 GHz)	(13 GHz – 26.5 GHz)
Mode	Tx 11n-20 MIMO, high power, 2462 MHz		
EUT Serial No.	A-1		
Antenna	Chain-0: Dual Monopole Antenna		
	Chain-1: Dual Monopole Antenna		

(\* PK: Peak, AV: Average, QP: Quasi-Peak)

Polarity	Frequency [MHz]	Detector	Reading [dBuV]	Ant.Fac. [dB/m]	Loss [dB]	Gain [dB]	Distance Factor [dB]	Result [dBuV/m]	Limit [dBuV/m]	Margin [dB]	Height [cm]	Angle [deg]	Remark
Hori.	2483.500	PK	66.31	28.24	14.23	41.62	2.15	69.31	73.9	4.5	161	77	-
Hori.	4924.000	PK	50.12	31.82	6.52	42.90	2.15	47.71	73.9	26.1	191	302	-
Hori.	7386.000	PK	48.33	37.49	8.00	43.28	2.15	52.69	73.9	21.2	100	0	-
Hori.	9848.000	PK	48.45	39.33	9.24	42.92	2.15	56.25	73.9	17.6	152	298	-
Hori.	2483.500	AV	45.59	28.24	14.23	41.62	2.15	48.59	53.9	5.3	161	77	VBW: 1 kHz
Hori.	4924.000	AV	38.50	31.82	6.52	42.90	2.15	36.09	53.9	17.8	191	302	VBW: 1 kHz
Hori.	7386.000	AV	37.51	37.49	8.00	43.28	2.15	41.87	53.9	12.0	100	0	VBW: 1 kHz
Hori.	9848.000	AV	37.73	39.33	9.24	42.92	2.15	45.53	53.9	8.3	152	298	VBW: 1 kHz
Vert.	2483.500	PK	68.96	28.24	14.23	41.62	2.15	71.96	73.9	1.9	158	92	-
Vert.	4924.000	PK	50.91	31.82	6.52	42.90	2.15	48.50	73.9	25.4	257	184	-
Vert.	7386.000	PK	48.43	37.49	8.00	43.28	2.15	52.79	73.9	21.1	100	0	-
Vert.	9848.000	PK	49.54	39.33	9.24	42.92	2.15	57.34	73.9	16.5	110	83	-
Vert.	2483.500	AV	45.66	28.24	14.23	41.62	2.15	48.66	53.9	5.2	158	92	VBW: 1 kHz
Vert.	4924.000	AV	39.91	31.82	6.52	42.90	2.15	37.50	53.9	16.4	257	184	VBW: 1 kHz
Vert.	7386.000	AV	37.38	37.49	8.00	43.28	2.15	41.74	53.9	12.1	100	0	VBW: 1 kHz
Vert.	9848.000	AV	38.83	39.33	9.24	42.92	2.15	46.63	53.9	7.2	110	83	VBW: 1 kHz

Result = Reading + Ant.Fac. + Loss (Cable+(Attenuator or Filter)(below 18 GHz)) - Gain(Amplifier) + Distance factor

Distance factor : 1 GHz - 13 GHz :  $20 \log (3.84 \text{ m} / 3.0 \text{ m}) = 2.15 \text{ dB}$

13 GHz - 40 GHz :  $20 \log (1.0 \text{ m} / 3.0 \text{ m}) = -9.54 \text{ dB}$

**UL Japan, Inc.**

**Shonan EMC Lab.**

1-22-3 Megumigaoka, Hiratsuka-shi, Kanagawa-ken, 259-1220 JAPAN

Telephone : +81 463 50 6400

Facsimile : +81 463 50 6401

**Radiated Spurious Emission**  
**(Reference Plot for band-edge)**

Report No. 13004393S-A-R2  
Test place Shonan EMC Lab.  
Semi Anechoic Chamber No.3  
Date September 4, 2019  
Temperature / Humidity 24 deg. C / 54 % RH  
Engineer Kenichi Adachi  
(1 GHz – 2.8 GHz)  
Mode Tx 11n-20 MIMO, high power, 2462 MHz  
EUT Serial No. A-1  
Antenna Chain-0: Dual Monopole Antenna  
Chain-1: Dual Monopole Antenna

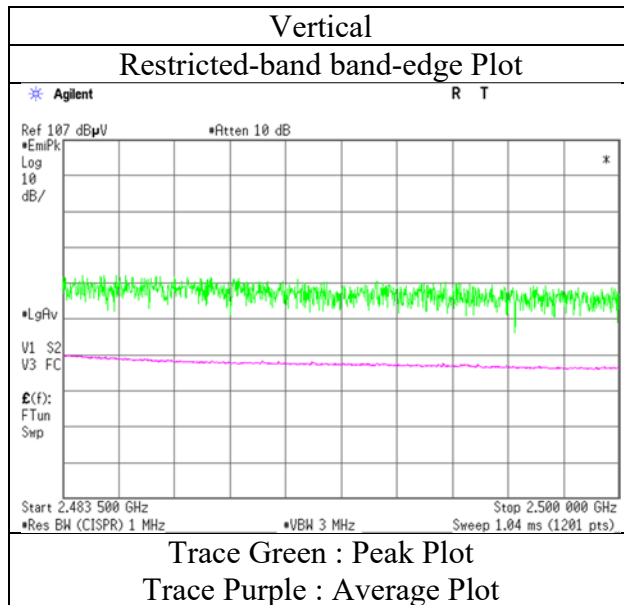
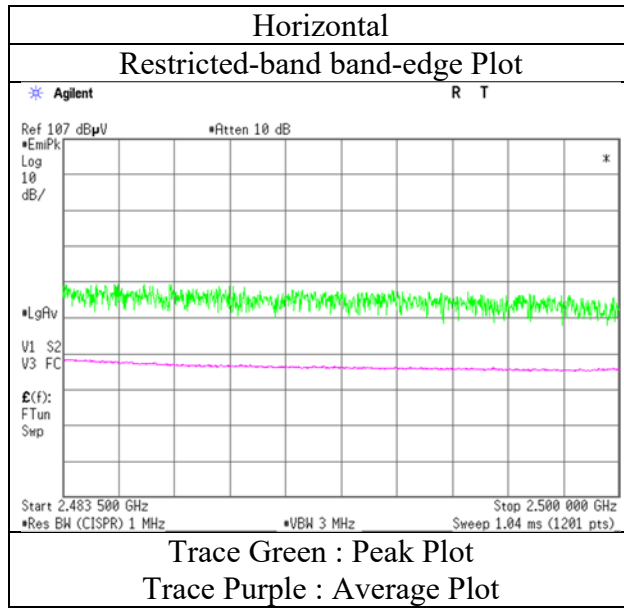

\* The measurement was conducted for a sufficiently long enough time to detect any possible spurious emissions.  
Final result of restricted band edge was shown in tabular data.

**Radiated Spurious Emission**

Report No. 13004393S-A-R2  
Test place Shonan EMC Lab.  
Semi Anechoic Chamber No.3 No.3 No.3  
Date September 8, 2019 September 9, 2019 September 13, 2019  
Temperature / Humidity 23 deg.C / 62 %RH 23 deg.C / 62 %RH 23 deg.C / 52 %RH  
Engineer Kenichi Adachi Kenichi Adachi Kazuya Noda  
(1 GHz – 2.8 GHz) (2.8 GHz – 13 GHz) (13 GHz – 26.5 GHz)  
Mode Tx, 11b, 2412, high power, MHz  
EUT Serial No. B-2  
Antenna Chain-0: Dual Monopole Antenna  
Chain-1: Slot Antenna

(\* PK: Peak, AV: Average, QP: Quasi-Peak)

Polarity	Frequency [MHz]	Detector	Reading [dBuV]	Ant.Fac. [dB/m]	Loss [dB]	Gain [dB]	Distance Factor [dB]	Result [dBuV/m]	Limit [dBuV/m]	Margin [dB]	Height [cm]	Angle [deg]	Remark
Hori.	2380.015	PK	52.98	28.36	14.14	41.59	2.04	55.93	73.9	17.9	149	78	-
Hori.	2390.000	PK	52.46	28.33	14.15	41.59	2.04	55.39	73.9	18.5	149	78	-
Hori.	4824.000	PK	47.88	31.64	6.46	42.88	2.04	45.14	73.9	28.7	145	64	-
Hori.	7236.000	PK	47.55	37.25	7.89	42.98	2.04	51.75	73.9	22.1	150	0	-
Hori.	9648.000	PK	48.61	38.97	9.18	43.13	2.04	55.67	73.9	18.2	143	43	-
Hori.	2380.015	AV	40.81	28.36	14.14	41.59	2.04	43.76	53.9	10.1	149	78	VBW: 30 Hz
Hori.	2390.000	AV	40.54	28.33	14.15	41.59	2.04	43.47	53.9	10.4	149	78	VBW: 30 Hz
Hori.	4824.000	AV	39.51	31.64	6.46	42.88	2.04	36.77	53.9	17.1	145	64	VBW: 30 Hz
Hori.	7236.000	AV	36.50	37.25	7.89	42.98	2.04	40.70	53.9	13.2	150	0	VBW: 30 Hz
Hori.	9648.000	AV	36.83	38.97	9.18	43.13	2.04	43.89	53.9	10.0	143	43	VBW: 30 Hz
Vert.	2380.015	PK	53.21	28.36	14.14	41.59	2.04	56.16	73.9	17.7	154	102	-
Vert.	2390.000	PK	53.04	28.33	14.15	41.59	2.04	55.97	73.9	17.9	154	102	-
Vert.	4824.000	PK	48.39	31.64	6.46	42.88	2.04	45.65	73.9	28.2	145	150	-
Vert.	7236.000	PK	47.75	37.25	7.89	42.98	2.04	51.95	73.9	21.9	133	0	-
Vert.	9648.000	PK	49.17	38.97	9.18	43.13	2.04	56.23	73.9	17.6	146	0	-
Vert.	2380.015	AV	41.82	28.36	14.14	41.59	2.04	44.77	53.9	9.1	154	102	VBW: 30 Hz
Vert.	2390.000	AV	40.91	28.33	14.15	41.59	2.04	43.84	53.9	10.0	154	102	VBW: 30 Hz
Vert.	4824.000	AV	39.57	31.64	6.46	42.88	2.04	36.83	53.9	17.0	145	150	VBW: 30 Hz
Vert.	7236.000	AV	36.70	37.25	7.89	42.98	2.04	40.90	53.9	13.0	133	0	VBW: 30 Hz
Vert.	9648.000	AV	37.17	38.97	9.18	43.13	2.04	44.23	53.9	9.6	146	0	VBW: 30 Hz

Result = Reading + Ant.Fac. + Loss (Cable+(Attenuator or Filter)(below 18 GHz)) - Gain(Amplifier) + Distance factor

Distance factor : 1 GHz - 13 GHz : 20 log (3.79 m / 3.0 m) = 2.04 dB

13 GHz - 40 GHz : 20log (1.0 m / 3.0 m) = -9.54 dB

**20 dBc Data Sheet (RBW 100 kHz, VBW 300 kHz)**

Polarity	Frequency [MHz]	Detector	Reading [dBuV]	Ant.Fac. [dB/m]	Loss [dB]	Gain [dB]	Distance Factor [dB]	Result [dBuV/m]	Limit [dBuV/m]	Margin [dB]	Remark
Hori.	2412.000	PK	103.48	28.29	14.16	41.60	2.04	106.37	-	-	- Carrier
Hori.	2400.000	PK	45.54	28.31	14.15	41.60	2.04	48.44	86.37	37.90	-
Vert.	2412.000	PK	104.54	28.29	14.16	41.60	2.04	107.43	-	-	- Carrier
Vert.	2400.000	PK	46.54	28.31	14.15	41.60	2.04	49.44	87.43	37.90	-

Result = Reading + Ant.Fac. + Loss (Cable+(Attenuator or Filter)(below 18 GHz)) - Gain(Amplifier) + Distance factor

Distance factor : 1 GHz - 13 GHz : 20 log (3.79 m / 3.0 m) = 2.04 dB

13 GHz - 40 GHz : 20log (1.0 m / 3.0 m) = -9.54 dB

## Radiated Spurious Emission (Reference Plot for band-edge)

Report No.	13004393S-A-R2
Test place	Shonan EMC Lab.
Semi Anechoic Chamber	No.3
Date	September 8, 2019
Temperature / Humidity	23 deg.C / 62 %RH
Engineer	Kenichi Adachi
	(1 GHz – 2.8 GHz)
Mode	Tx, 11b, high power, 2412 MHz
EUT Serial No.	B-2
Antenna	Chain-0: Dual Monopole Antenna Chain-1: Slot Antenna

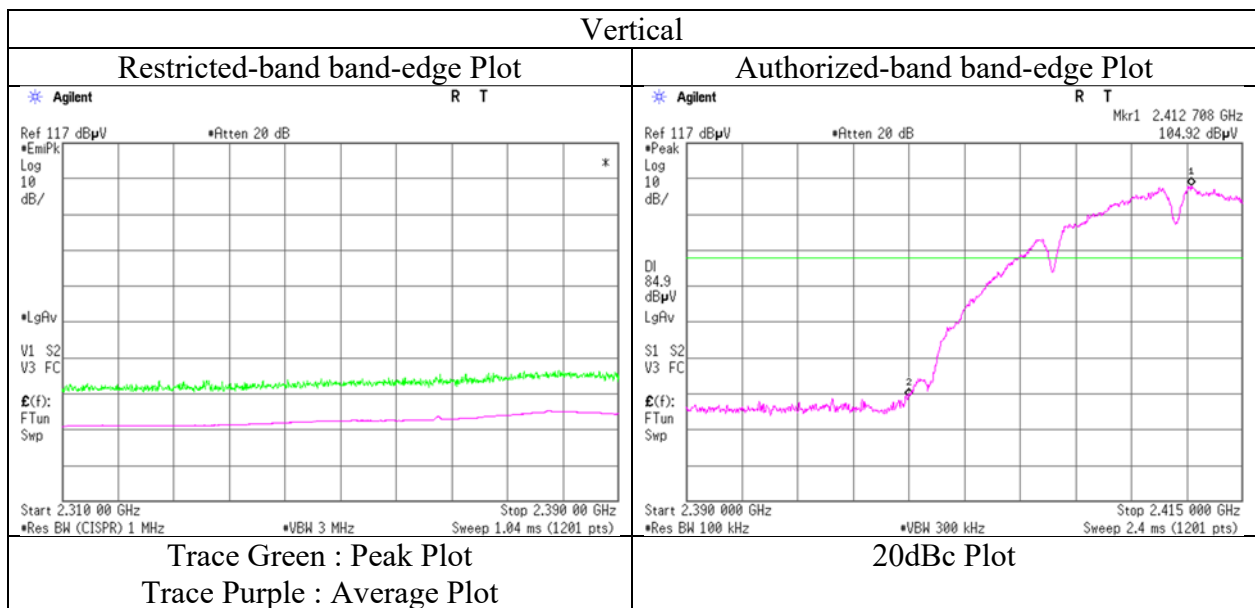
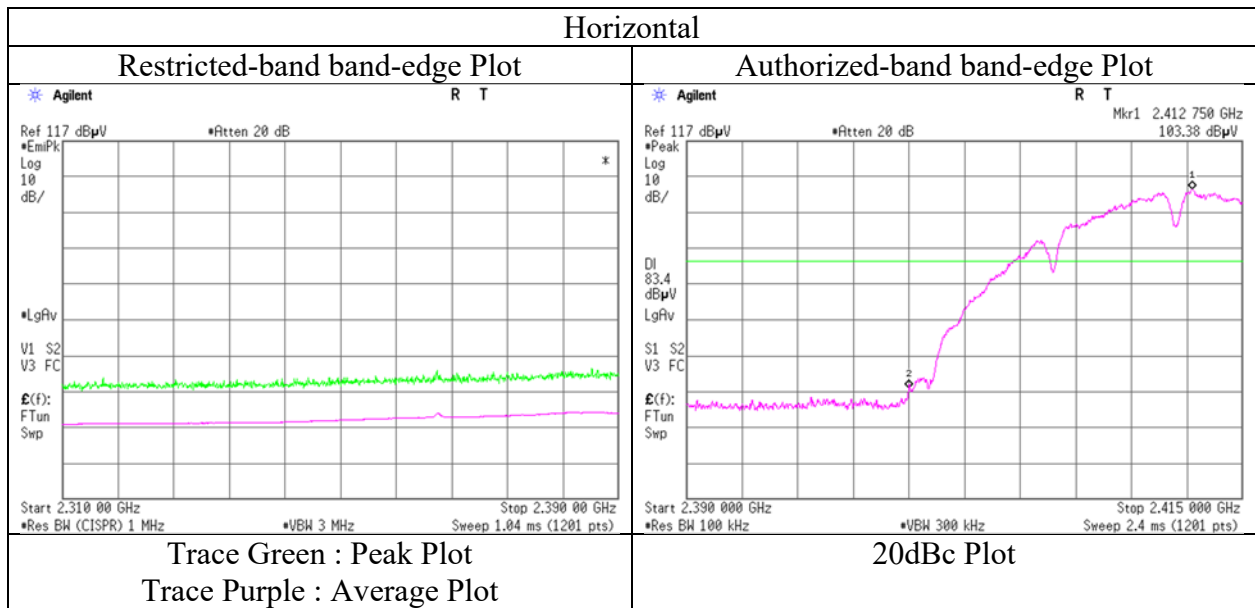

\* The measurement was conducted for a sufficiently long enough time to detect any possible spurious emissions. Final result of restricted band edge was shown in tabular data.

## Radiated Spurious Emission

Report No. 13004393S-A-R2  
Test place Shonan EMC Lab.  
Semi Anechoic Chamber No.3 No.3  
Date September 10, 2019 September 13, 2019  
Temperature / Humidity 23 deg.C / 58 %RH 23 deg.C / 52 %RH  
Engineer Takahiro Kawakami Kazuya Noda  
(1 GHz – 13 GHz) (13 GHz – 26.5 GHz)  
Mode Tx 11b, high power, 2437 MHz  
EUT Serial No. B-2  
Antenna Chain-0: Dual Monopole Antenna  
Chain-1: Slot Antenna

(\* PK: Peak, AV: Average, QP: Quasi-Peak)

Polarity	Frequency [MHz]	Detector	Reading [dBuV]	Ant.Fac. [dB/m]	Loss [dB]	Gain [dB]	Distance Factor [dB]	Result [dBuV/m]	Limit [dBuV/m]	Margin [dB]	Height [cm]	Angle [deg]	Remark
Hori.	4874.000	PK	48.92	31.70	6.49	42.89	2.04	46.26	73.9	27.6	133	69	-
Hori.	7311.000	PK	48.55	37.36	7.95	43.13	2.04	52.77	73.9	21.1	166	0	-
Hori.	9748.000	PK	47.61	39.31	9.21	43.02	2.04	55.15	73.9	18.7	100	0	-
Hori.	4874.000	AV	40.33	31.70	6.49	42.89	2.04	37.67	53.9	16.2	133	69	VBW: 30 Hz
Hori.	7311.000	AV	36.50	37.36	7.95	43.13	2.04	40.72	53.9	13.1	166	0	VBW: 30 Hz
Hori.	9748.000	AV	36.49	39.31	9.21	43.02	2.04	44.03	53.9	9.8	100	0	VBW: 30 Hz
Vert.	4874.000	PK	50.26	31.70	6.49	42.89	2.04	47.60	73.9	26.3	156	0	-
Vert.	7311.000	PK	48.56	37.36	7.95	43.13	2.04	52.78	73.9	21.1	140	0	-
Vert.	9748.000	PK	48.41	39.31	9.21	43.02	2.04	55.95	73.9	17.9	100	0	-
Vert.	4874.000	AV	40.68	31.70	6.49	42.89	2.04	38.02	53.9	15.8	156	0	VBW: 30 Hz
Vert.	7311.000	AV	36.47	37.36	7.95	43.13	2.04	40.69	53.9	13.2	140	0	VBW: 30 Hz
Vert.	9748.000	AV	36.67	39.31	9.21	43.02	2.04	44.21	53.9	9.6	100	0	VBW: 30 Hz

Result = Reading + Ant.Fac. + Loss (Cable+(Attenuator or Filter)(below 18 GHz)) - Gain(Amplifier) + Distance factor

Distance factor : 1 GHz - 13 GHz :  $20 \log(3.79 \text{ m} / 3.0 \text{ m}) = 2.04 \text{ dB}$

13 GHz - 40 GHz :  $20 \log(1.0 \text{ m} / 3.0 \text{ m}) = -9.54 \text{ dB}$

**UL Japan, Inc.**

**Shonan EMC Lab.**

1-22-3 Megumigaoka, Hiratsuka-shi, Kanagawa-ken, 259-1220 JAPAN

Telephone : +81 463 50 6400

Facsimile : +81 463 50 6401

## Radiated Spurious Emission

Report No.	13004393S-A-R2		
Test place	Shonan EMC Lab.		
Semi Anechoic Chamber	No.3	No.3	No.3
Date	September 8, 2019	September 9, 2019	September 13, 2019
Temperature / Humidity	23 deg.C / 62 %RH	23 deg.C / 62 %RH	23 deg.C / 52 %RH
Engineer	Kenichi Adachi	Kenichi Adachi	Kazuya Noda
	(1 GHz – 2.8 GHz)	(2.8 GHz – 13 GHz)	(13 GHz – 26.5 GHz)
Mode	Tx 11b, high power, 2462 MHz		
EUT Serial No.	B-2		
Antenna	Chain-0: Dual Monopole Antenna		
	Chain-1: Slot Antenna		

(\* PK: Peak, AV: Average, QP: Quasi-Peak)

Polarity	Frequency [MHz]	Detector	Reading [dBuV]	Ant.Fac. [dB/m]	Loss [dB]	Gain [dB]	Distance Factor [dB]	Result [dBuV/m]	Limit [dBuV/m]	Margin [dB]	Height [cm]	Angle [deg]	Remark
Hori.	2483.500	PK	51.02	28.24	14.23	41.62	2.04	53.91	73.9	19.9	145	84	-
Hori.	2488.032	PK	52.62	28.23	14.23	41.63	2.04	55.49	73.9	18.4	145	84	-
Hori.	4924.000	PK	48.05	31.82	6.52	42.90	2.04	45.53	73.9	28.3	128	66	-
Hori.	7386.000	PK	48.25	37.49	8.00	43.28	2.04	52.50	73.9	21.4	100	0	-
Hori.	9848.000	PK	48.12	39.33	9.24	42.92	2.04	55.81	73.9	18.0	132	0	-
Hori.	2483.500	AV	39.22	28.24	14.23	41.62	2.04	42.11	53.9	11.7	145	84	VBW: 30 Hz
Hori.	2488.032	AV	39.58	28.23	14.23	41.63	2.04	42.45	53.9	11.4	145	84	VBW: 30 Hz
Hori.	4924.000	AV	38.76	31.82	6.52	42.90	2.04	36.24	53.9	17.6	128	66	VBW: 30 Hz
Hori.	7386.000	AV	36.65	37.49	8.00	43.28	2.04	40.90	53.9	13.0	100	0	VBW: 30 Hz
Hori.	9848.000	AV	36.63	39.33	9.24	42.92	2.04	44.32	53.9	9.5	132	0	VBW: 30 Hz
Vert.	2483.500	PK	51.19	28.24	14.23	41.62	2.04	54.08	73.9	19.8	139	104	-
Vert.	2488.032	PK	52.84	28.23	14.23	41.63	2.04	55.71	73.9	18.1	139	104	-
Vert.	4924.000	PK	48.46	31.82	6.52	42.90	2.04	45.94	73.9	27.9	142	298	-
Vert.	7386.000	PK	47.99	37.49	8.00	43.28	2.04	52.24	73.9	21.6	150	0	-
Vert.	9848.000	PK	47.36	39.33	9.24	42.92	2.04	55.05	73.9	18.8	100	0	-
Vert.	2483.500	AV	40.39	28.24	14.23	41.62	2.04	43.28	53.9	10.6	139	104	VBW: 30 Hz
Vert.	2488.032	AV	40.83	28.23	14.23	41.63	2.04	43.70	53.9	10.2	139	104	VBW: 30 Hz
Vert.	4924.000	AV	39.33	31.82	6.52	42.90	2.04	36.81	53.9	17.0	142	298	VBW: 30 Hz
Vert.	7386.000	AV	36.90	37.49	8.00	43.28	2.04	41.15	53.9	12.7	150	0	VBW: 30 Hz
Vert.	9848.000	AV	36.39	39.33	9.24	42.92	2.04	44.08	53.9	9.8	100	0	VBW: 30 Hz

Result = Reading + Ant.Fac. + Loss (Cable+(Attenuator or Filter)(below 18 GHz)) - Gain(Amplifier) + Distance factor

Distance factor : 1 GHz - 13 GHz :  $20 \log(3.79 \text{ m} / 3.0 \text{ m}) = 2.04 \text{ dB}$

13 GHz - 40 GHz :  $20 \log(1.0 \text{ m} / 3.0 \text{ m}) = -9.54 \text{ dB}$

**UL Japan, Inc.**

**Shonan EMC Lab.**

1-22-3 Megumigaoka, Hiratsuka-shi, Kanagawa-ken, 259-1220 JAPAN

Telephone : +81 463 50 6400

Facsimile : +81 463 50 6401

**Radiated Spurious Emission**  
**(Reference Plot for band-edge)**

Report No. 13004393S-A-R2  
Test place Shonan EMC Lab.  
Semi Anechoic Chamber No.3  
Date September 8, 2019  
Temperature / Humidity 23 deg.C / 62 %RH  
Engineer Kenichi Adachi  
(1 GHz – 2.8 GHz)  
Mode Tx 11b, high power, 2462 MHz  
EUT Serial No. B-2  
Antenna Chain-0: Dual Monopole Antenna  
Chain-1: Slot Antenna

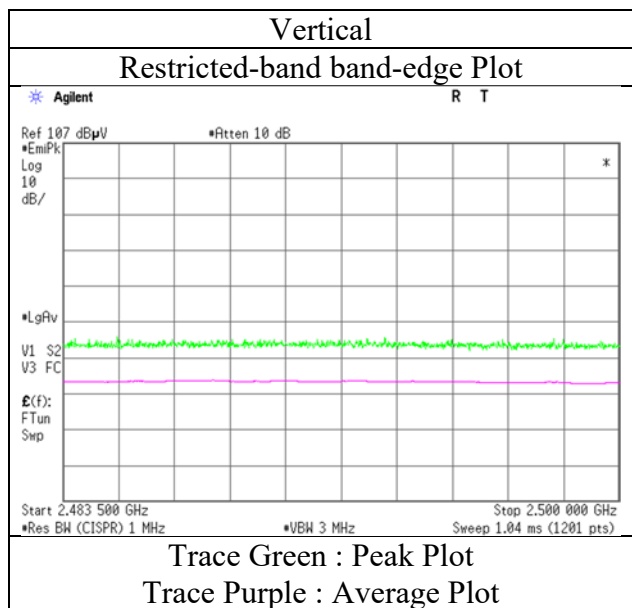
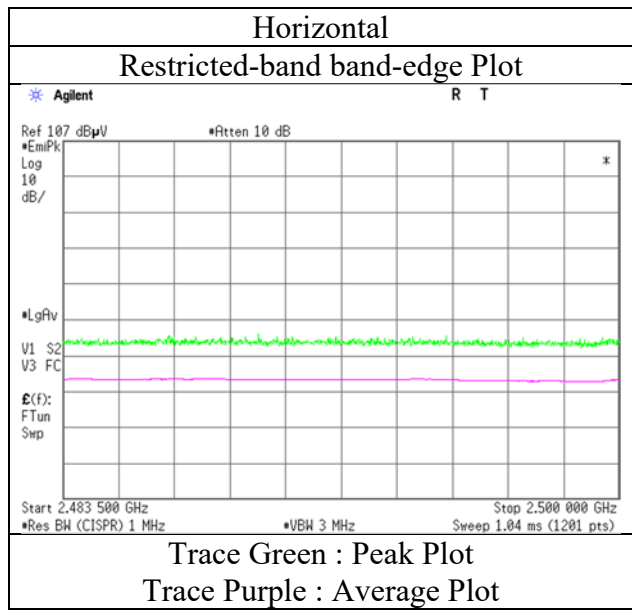

\* The measurement was conducted for a sufficiently long enough time to detect any possible spurious emissions.  
Final result of restricted band edge was shown in tabular data.





**Radiated Spurious Emission**  
**(Reference Plot for band-edge)**

Report No. 13004393S-A-R2  
Test place Shonan EMC Lab.  
Semi Anechoic Chamber No.3  
Date September 9, 2019  
Temperature / Humidity 23 deg.C / 62 %RH  
Engineer Kenichi Adachi  
(1 GHz – 13 GHz)  
Mode Tx 11g, high power, 2412 MHz  
EUT Serial No. B-2  
Antenna Chain-0: Dual Monopole Antenna  
Chain-1: Slot Antenna

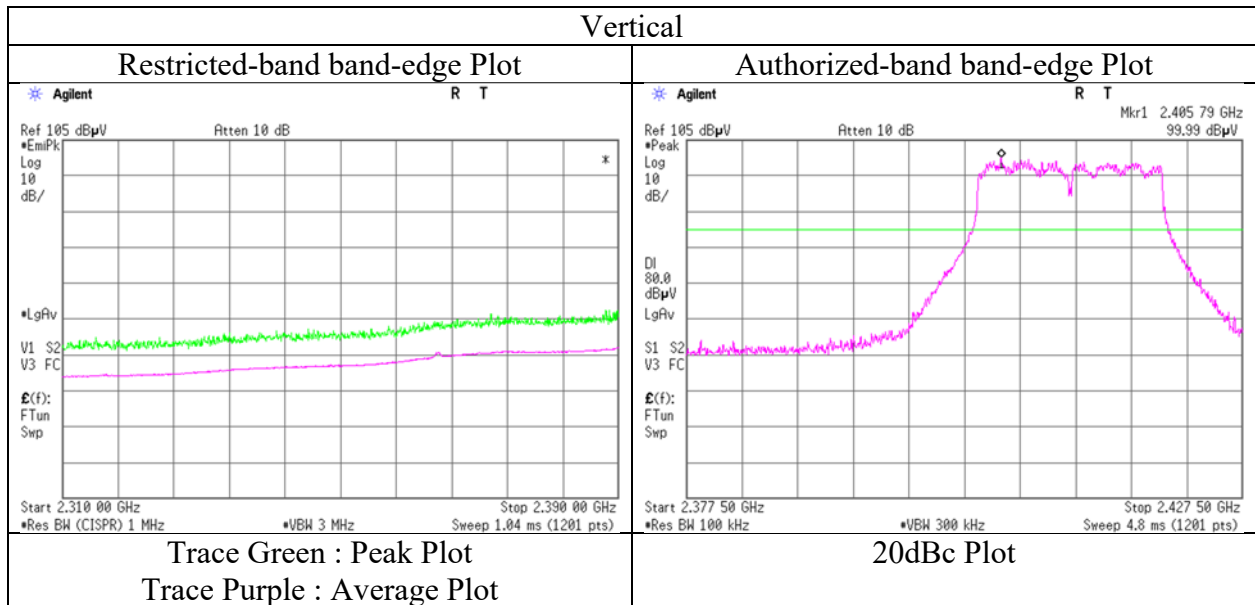
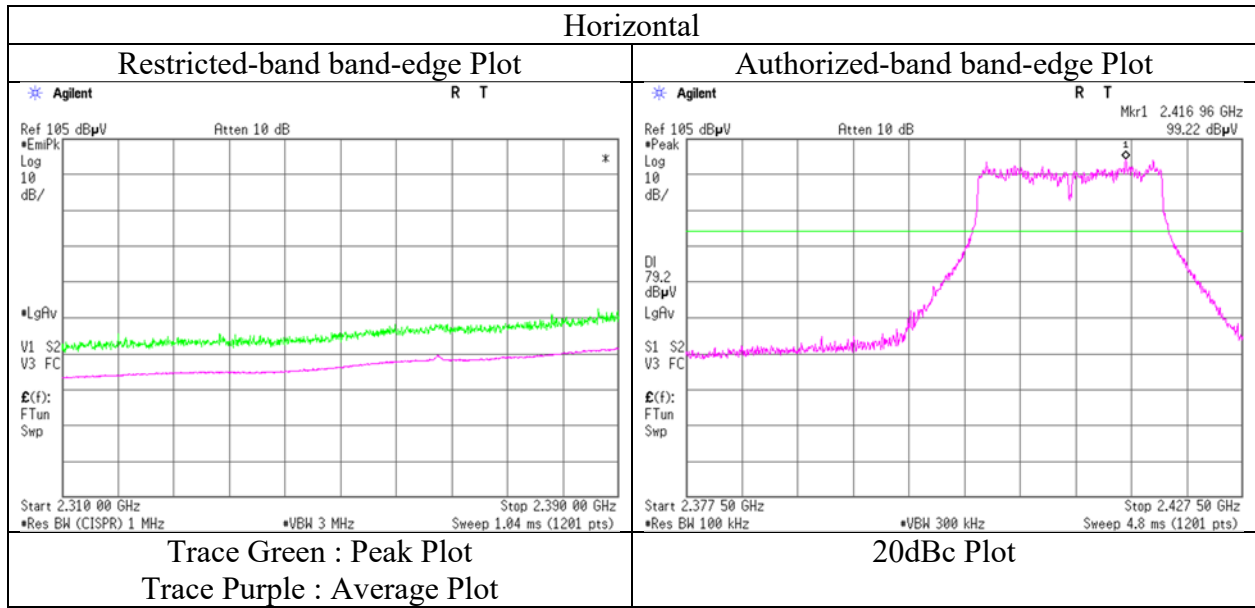

\* The measurement was conducted for a sufficiently long enough time to detect any possible spurious emissions.  
Final result of restricted band edge was shown in tabular data.

## Radiated Spurious Emission

Report No. 13004393S-A-R2  
Test place Shonan EMC Lab.  
Semi Anechoic Chamber No.3 No.3  
Date September 10, 2019 September 13, 2019  
Temperature / Humidity 23 deg.C / 58 %RH 23 deg.C / 52 %RH  
Engineer Takahiro Kawakami Kazuya Noda  
(1 GHz – 13 GHz) (13 GHz – 26.5 GHz)  
Mode Tx 11g, high power, 2437 MHz  
EUT Serial No. B-2  
Antenna Chain-0: Dual Monopole Antenna  
Chain-1: Slot Antenna

(\* PK: Peak, AV: Average, QP: Quasi-Peak)

Polarity	Frequency [MHz]	Detector	Reading [dBuV]	Ant.Fac. [dB/m]	Loss [dB]	Gain [dB]	Distance Factor [dB]	Result [dBuV/m]	Limit [dBuV/m]	Margin [dB]	Height [cm]	Angle [deg]	Remark
Hori.	4874.000	PK	48.21	31.70	6.49	42.89	2.04	45.55	73.9	28.3	146	0	-
Hori.	7311.000	PK	47.93	37.36	7.95	43.13	2.04	52.15	73.9	21.7	144	78	-
Hori.	9748.000	PK	47.37	39.31	9.21	43.02	2.04	54.91	73.9	18.9	100	0	-
Hori.	4874.000	AV	37.62	31.70	6.49	42.89	2.04	34.96	53.9	18.9	146	0	VBW: 300 Hz
Hori.	7311.000	AV	36.85	37.36	7.95	43.13	2.04	41.07	53.9	12.8	144	78	VBW: 300 Hz
Hori.	9748.000	AV	36.45	39.31	9.21	43.02	2.04	43.99	53.9	9.9	100	0	VBW: 300 Hz
Vert.	4874.000	PK	50.40	31.70	6.49	42.89	2.04	47.74	73.9	26.1	142	8	-
Vert.	7311.000	PK	49.13	37.36	7.95	43.13	2.04	53.35	73.9	20.5	103	0	-
Vert.	9748.000	PK	48.74	39.31	9.21	43.02	2.04	56.28	73.9	17.6	100	0	-
Vert.	4874.000	AV	39.53	31.70	6.49	42.89	2.04	36.87	53.9	17.0	142	8	VBW: 300 Hz
Vert.	7311.000	AV	36.64	37.36	7.95	43.13	2.04	40.86	53.9	13.0	103	0	VBW: 300 Hz
Vert.	9748.000	AV	37.22	39.31	9.21	43.02	2.04	44.76	53.9	9.1	100	0	VBW: 300 Hz

Result = Reading + Ant.Fac. + Loss (Cable+(Attenuator or Filter)(below 18 GHz)) - Gain(Amplifier) + Distance factor

Distance factor : 1 GHz - 13 GHz :  $20 \log(3.79 \text{ m} / 3.0 \text{ m}) = 2.04 \text{ dB}$

13 GHz - 40 GHz :  $20 \log(1.0 \text{ m} / 3.0 \text{ m}) = -9.54 \text{ dB}$

**UL Japan, Inc.**

**Shonan EMC Lab.**

1-22-3 Megumigaoka, Hiratsuka-shi, Kanagawa-ken, 259-1220 JAPAN

Telephone : +81 463 50 6400

Facsimile : +81 463 50 6401

## Radiated Spurious Emission

Report No. 13004393S-A-R2  
Test place Shonan EMC Lab.  
Semi Anechoic Chamber No.3 No.3  
Date September 9, 2019 September 13, 2019  
Temperature / Humidity 23 deg.C / 62 %RH 23 deg.C / 52 %RH  
Engineer Kenichi Adachi Kazuya Noda  
(1 GHz – 13 GHz) (13 GHz – 26.5 GHz)  
Mode Tx 11g, high power, 2462 MHz  
EUT Serial No. B-2  
Antenna Chain-0: Dual Monopole Antenna  
Chain-1: Slot Antenna

(\* PK: Peak, AV: Average, QP: Quasi-Peak)

Polarity	Frequency [MHz]	Detector	Reading [dBuV]	Ant.Fac. [dB/m]	Loss [dB]	Gain [dB]	Distance Factor [dB]	Result [dBuV/m]	Limit [dBuV/m]	Margin [dB]	Height [cm]	Angle [deg]	Remark
Hori.	2483.500	PK	64.25	28.24	14.23	41.62	2.04	67.14	73.9	6.7	154	89	-
Hori.	4924.000	PK	50.32	31.82	6.52	42.90	2.04	47.80	73.9	26.1	143	0	-
Hori.	7386.000	PK	50.69	37.49	8.00	43.28	2.04	54.94	73.9	18.9	155	358	-
Hori.	9848.000	PK	49.08	39.33	9.24	42.92	2.04	56.77	73.9	17.1	100	0	-
Hori.	2483.500	AV	48.27	28.24	14.23	41.62	2.04	51.16	53.9	2.7	154	89	VBW: 300 Hz
Hori.	4924.000	AV	38.54	31.82	6.52	42.90	2.04	36.02	53.9	17.8	143	0	VBW: 300 Hz
Hori.	7386.000	AV	38.60	37.49	8.00	43.28	2.04	42.85	53.9	11.0	155	358	VBW: 300 Hz
Hori.	9848.000	AV	37.82	39.33	9.24	42.92	2.04	45.51	53.9	8.3	100	0	VBW: 300 Hz
Vert.	2483.500	PK	66.35	28.24	14.23	41.62	2.04	69.24	73.9	4.6	142	106	-
Vert.	4924.000	PK	48.13	31.82	6.52	42.90	2.04	45.61	73.9	28.2	149	66	-
Vert.	7386.000	PK	47.41	37.49	8.00	43.28	2.04	51.66	73.9	22.2	133	0	-
Vert.	9848.000	PK	47.35	39.33	9.24	42.92	2.04	55.04	73.9	18.8	100	0	-
Vert.	2483.500	AV	49.26	28.24	14.23	41.62	2.04	52.15	53.9	1.7	142	106	VBW: 300 Hz
Vert.	4924.000	AV	36.78	31.82	6.52	42.90	2.04	34.26	53.9	19.6	149	66	VBW: 300 Hz
Vert.	7386.000	AV	36.91	37.49	8.00	43.28	2.04	41.16	53.9	12.7	133	0	VBW: 300 Hz
Vert.	9848.000	AV	37.04	39.33	9.24	42.92	2.04	44.73	53.9	9.1	100	0	VBW: 300 Hz

Result = Reading + Ant.Fac. + Loss (Cable+(Attenuator or Filter)(below 18 GHz)) - Gain(Amplifier) + Distance factor

Distance factor : 1 GHz - 13 GHz :  $20 \log (3.79 \text{ m} / 3.0 \text{ m}) = 2.04 \text{ dB}$

13 GHz - 40 GHz :  $20 \log (1.0 \text{ m} / 3.0 \text{ m}) = -9.54 \text{ dB}$

**UL Japan, Inc.**

**Shonan EMC Lab.**

1-22-3 Megumigaoka, Hiratsuka-shi, Kanagawa-ken, 259-1220 JAPAN

Telephone : +81 463 50 6400

Facsimile : +81 463 50 6401

**Radiated Spurious Emission**  
**(Reference Plot for band-edge)**

Report No. 13004393S-A-R2  
Test place Shonan EMC Lab.  
Semi Anechoic Chamber No.3  
Date September 9, 2019  
Temperature / Humidity 23 deg.C / 62 %RH  
Engineer Kenichi Adachi  
(1 GHz – 13 GHz)  
Mode Tx 11g, high power, 2462 MHz  
EUT Serial No. B-2  
Antenna Chain-0: Dual Monopole Antenna  
Chain-1: Slot Antenna

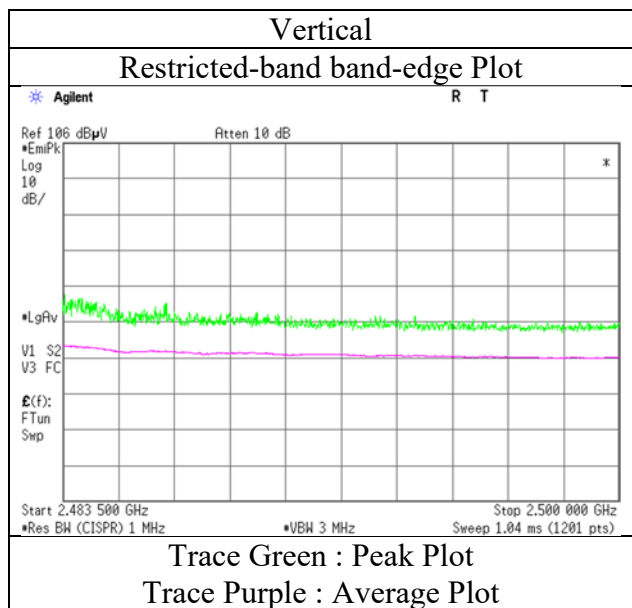
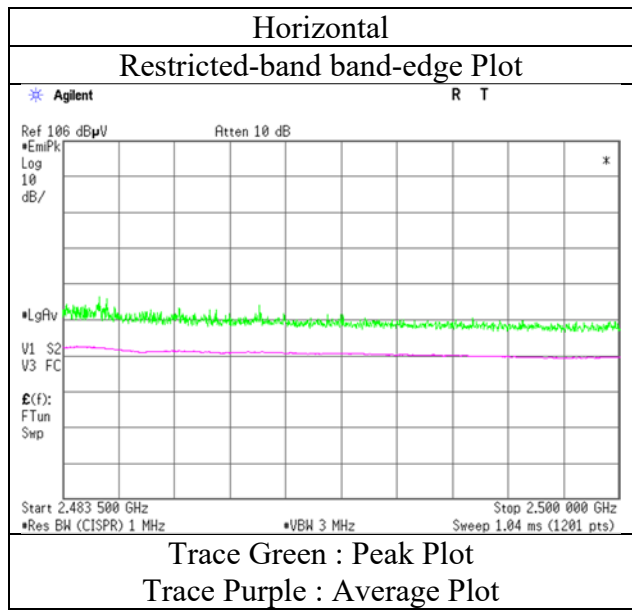

\* The measurement was conducted for a sufficiently long enough time to detect any possible spurious emissions. Final result of restricted band edge was shown in tabular data.

## Radiated Spurious Emission

Report No. 13004393S-A-R2  
Test place Shonan EMC Lab.  
Semi Anechoic Chamber No.3 No.3 No.3  
Date September 8, 2019 September 10, 2019 September 13, 2019  
Temperature / Humidity 23 deg.C / 62 %RH 23 deg.C / 58 %RH 23 deg.C / 52 %RH  
Engineer Kenichi Adachi Takahiro Kawakami Kazuya Noda  
(1 GHz – 2.8 GHz) (2.8 GHz – 13 GHz) (13 GHz – 26.5 GHz)  
Mode Tx 11n-20 MIMO, high power, 2412 MHz  
EUT Serial No. B-2  
Antenna Chain-0: Dual Monopole Antenna  
Chain-1: Slot Antenna

(\* PK: Peak, AV: Average, QP: Quasi-Peak)

Polarity	Frequency [MHz]	Detector	Reading [dBuV]	Ant.Fac. [dB/m]	Loss [dB]	Gain [dB]	Distance Factor [dB]	Result [dBuV/m]	Limit [dBuV/m]	Margin [dB]	Height [cm]	Angle [deg]	Remark
Hori.	2390.000	PK	60.94	28.33	14.15	41.59	2.04	63.87	73.9	10.0	138	96	-
Hori.	4824.000	PK	50.14	31.64	6.46	42.88	2.04	47.40	73.9	26.5	149	0	-
Hori.	7236.000	PK	49.04	37.25	7.89	42.98	2.04	53.24	73.9	20.6	137	0	-
Hori.	9648.000	PK	49.54	38.97	9.18	43.13	2.04	56.60	73.9	17.3	150	19	-
Hori.	2390.000	AV	45.14	28.33	14.15	41.59	2.04	48.07	53.9	5.8	138	96	VBW: 1 kHz
Hori.	4824.000	AV	38.52	31.64	6.46	42.88	2.04	35.78	53.9	18.1	149	0	VBW: 1 kHz
Hori.	7236.000	AV	37.49	37.25	7.89	42.98	2.04	41.69	53.9	12.2	137	0	VBW: 1 kHz
Hori.	9648.000	AV	38.52	38.97	9.18	43.13	2.04	45.58	53.9	8.3	150	19	VBW: 1 kHz
Vert.	2390.000	PK	64.59	28.33	14.15	41.59	2.04	67.52	73.9	6.3	150	104	-
Vert.	4824.000	PK	49.50	31.64	6.46	42.88	2.04	46.76	73.9	27.1	165	335	-
Vert.	7236.000	PK	48.53	37.25	7.89	42.98	2.04	52.73	73.9	21.1	143	0	-
Vert.	9648.000	PK	48.90	38.97	9.18	43.13	2.04	55.96	73.9	17.9	100	0	-
Vert.	2390.000	AV	46.64	28.33	14.15	41.59	2.04	49.57	53.9	4.3	150	104	VBW: 1 kHz
Vert.	4824.000	AV	37.17	31.64	6.46	42.88	2.04	34.43	53.9	19.4	165	335	VBW: 1 kHz
Vert.	7236.000	AV	37.10	37.25	7.89	42.98	2.04	41.30	53.9	12.6	143	0	VBW: 1 kHz
Vert.	9648.000	AV	37.84	38.97	9.18	43.13	2.04	44.90	53.9	9.0	100	0	VBW: 1 kHz

Result = Reading + Ant.Fac. + Loss (Cable+(Attenuator or Filter)(below 18 GHz)) - Gain(Amplifier) + Distance factor

Distance factor : 1 GHz - 13 GHz :  $20 \log(3.79 \text{ m} / 3.0 \text{ m}) = 2.04 \text{ dB}$

13 GHz - 40 GHz :  $20 \log(1.0 \text{ m} / 3.0 \text{ m}) = -9.54 \text{ dB}$

### 20 dBc Data Sheet (RBW 100 kHz, VBW 300 kHz)

Polarity	Frequency [MHz]	Detector	Reading [dBuV]	Ant.Fac. [dB/m]	Loss [dB]	Gain [dB]	Distance Factor [dB]	Result [dBuV/m]	Limit [dBuV/m]	Margin [dB]	Remark
Hori.	2412.000	PK	98.54	28.29	14.16	41.60	2.04	101.43	-	-	Carrier
Hori.	2400.000	PK	62.08	28.31	14.15	41.60	2.04	64.98	81.43	16.40	-
Vert.	2412.000	PK	100.75	28.29	14.16	41.60	2.04	103.64	-	-	Carrier
Vert.	2400.000	PK	63.35	28.31	14.15	41.60	2.04	66.25	83.64	17.30	-

Result = Reading + Ant.Fac. + Loss (Cable+(Attenuator or Filter)(below 18 GHz)) - Gain(Amplifier) + Distance factor

Distance factor : 1 GHz - 13 GHz :  $20 \log(3.79 \text{ m} / 3.0 \text{ m}) = 2.04 \text{ dB}$

13 GHz - 40 GHz :  $20 \log(1.0 \text{ m} / 3.0 \text{ m}) = -9.54 \text{ dB}$

## Radiated Spurious Emission (Reference Plot for band-edge)

Report No.	13004393S-A-R2
Test place	Shonan EMC Lab.
Semi Anechoic Chamber	No.3
Date	September 8, 2019
Temperature / Humidity	23 deg.C / 62 %RH
Engineer	Kenichi Adachi
	(1 GHz – 2.8 GHz)
Mode	Tx 11n-20 MIMO, high power, 2412 MHz
EUT Serial No.	B-2
Antenna	Chain-0: Dual Monopole Antenna Chain-1: Slot Antenna

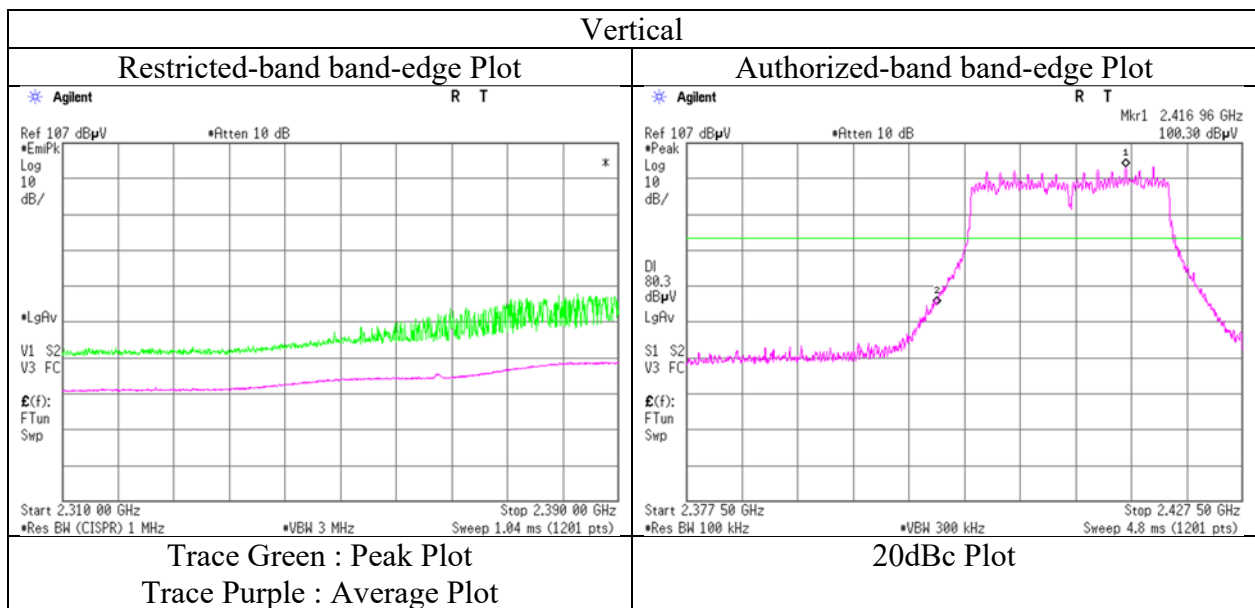
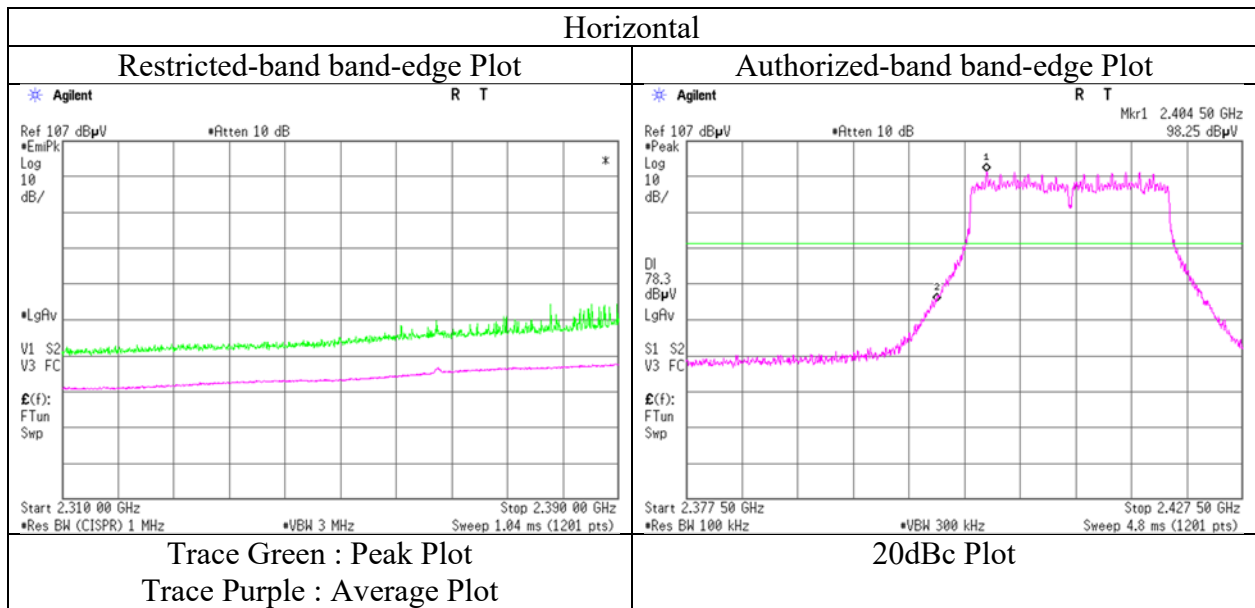

\* The measurement was conducted for a sufficiently long enough time to detect any possible spurious emissions. Final result of restricted band edge was shown in tabular data.

## Radiated Spurious Emission

Report No. 13004393S-A-R2  
Test place Shonan EMC Lab.  
Semi Anechoic Chamber No.3 No.3  
Date September 10, 2019 September 13, 2019  
Temperature / Humidity 23 deg.C / 58 %RH 23 deg.C / 52 %RH  
Engineer Takahiro Kawakami Kazuya Noda  
(1 GHz – 13 GHz) (13 GHz – 26.5 GHz)  
Mode Tx 11n-20 MIMO, high power, 2437 MHz  
EUT Serial No. B-2  
Antenna Chain-0: Dual Monopole Antenna  
Chain-1: Slot Antenna

(\* PK: Peak, AV: Average, QP: Quasi-Peak)

Polarity	Frequency [MHz]	Detector	Reading [dBuV]	Ant.Fac. [dB/m]	Loss [dB]	Gain [dB]	Distance Factor [dB]	Result [dBuV/m]	Limit [dBuV/m]	Margin [dB]	Height [cm]	Angle [deg]	Remark
Hori.	4874.000	PK	49.81	31.70	6.49	42.89	2.04	47.15	73.9	26.8	124	0	-
Hori.	7311.000	PK	48.21	37.36	7.95	43.13	2.04	52.43	73.9	21.5	100	0	-
Hori.	9748.000	PK	47.93	39.31	9.21	43.02	2.04	55.47	73.9	18.4	100	0	-
Hori.	4874.000	AV	38.25	31.70	6.49	42.89	2.04	35.59	53.9	18.3	124	0	VBW: 1 kHz
Hori.	7311.000	AV	37.14	37.36	7.95	43.13	2.04	41.36	53.9	12.5	100	0	VBW: 1 kHz
Hori.	9748.000	AV	37.07	39.31	9.21	43.02	2.04	44.61	53.9	9.3	100	0	VBW: 1 kHz
Vert.	4874.000	PK	49.74	31.70	6.49	42.89	2.04	47.08	73.9	26.8	143	7	-
Vert.	7311.000	PK	48.32	37.36	7.95	43.13	2.04	52.54	73.9	21.4	153	117	-
Vert.	9748.000	PK	47.88	39.31	9.21	43.02	2.04	55.42	73.9	18.5	100	0	-
Vert.	4874.000	AV	39.05	31.70	6.49	42.89	2.04	36.39	53.9	17.5	143	7	VBW: 1 kHz
Vert.	7311.000	AV	37.17	37.36	7.95	43.13	2.04	41.39	53.9	12.5	153	117	VBW: 1 kHz
Vert.	9748.000	AV	37.21	39.31	9.21	43.02	2.04	44.75	53.9	9.1	100	0	VBW: 1 kHz

Result = Reading + Ant.Fac. + Loss (Cable+(Attenuator or Filter)(below 18 GHz)) - Gain(Amplifier) + Distance factor

Distance factor : 1 GHz - 13 GHz :  $20 \log (3.79 \text{ m} / 3.0 \text{ m}) = 2.04 \text{ dB}$

13 GHz - 40 GHz :  $20 \log (1.0 \text{ m} / 3.0 \text{ m}) = -9.54 \text{ dB}$

**UL Japan, Inc.**

**Shonan EMC Lab.**

1-22-3 Megumigaoka, Hiratsuka-shi, Kanagawa-ken, 259-1220 JAPAN

Telephone : +81 463 50 6400

Facsimile : +81 463 50 6401

## Radiated Spurious Emission

Report No.	13004393S-A-R2		
Test place	Shonan EMC Lab.		
Semi Anechoic Chamber	No.3	No.3	No.3
Date	September 8, 2019	September 10, 2019	September 13, 2019
Temperature / Humidity	23 deg.C / 62 %RH	23 deg.C / 58 %RH	23 deg.C / 52 %RH
Engineer	Kenichi Adachi	Takahiro Kawakami	Kazuya Noda
	(1 GHz – 2.8 GHz)	(2.8 GHz – 13 GHz)	(13 GHz – 26.5 GHz)
Mode	Tx 11n-20 MIMO, high power, 2462 MHz		
EUT Serial No.	B-2		
Antenna	Chain-0: Dual Monopole Antenna		
	Chain-1: Slot Antenna		

(\* PK: Peak, AV: Average, QP: Quasi-Peak)

Polarity	Frequency [MHz]	Detector	Reading [dBuV]	Ant.Fac. [dB/m]	Loss [dB]	Gain [dB]	Distance Factor [dB]	Result [dBuV/m]	Limit [dBuV/m]	Margin [dB]	Height [cm]	Angle [deg]	Remark
Hori.	2483.500	PK	59.98	28.24	14.23	41.62	2.04	62.87	73.9	11.0	139	83	-
Hori.	4924.000	PK	49.14	31.82	6.52	42.90	2.04	46.62	73.9	27.2	131	0	-
Hori.	7386.000	PK	48.65	37.49	8.00	43.28	2.04	52.90	73.9	21.0	152	12	-
Hori.	9848.000	PK	47.51	39.33	9.24	42.92	2.04	55.20	73.9	18.7	100	0	-
Hori.	2483.500	AV	47.45	28.24	14.23	41.62	2.04	50.34	53.9	3.5	139	83	VBW: 1 kHz
Hori.	4924.000	AV	38.25	31.82	6.52	42.90	2.04	35.73	53.9	18.1	131	0	VBW: 1 kHz
Hori.	7386.000	AV	37.21	37.49	8.00	43.28	2.04	41.46	53.9	12.4	152	12	VBW: 1 kHz
Hori.	9848.000	AV	36.91	39.33	9.24	42.92	2.04	44.60	53.9	9.3	100	0	VBW: 1 kHz
Vert.	2483.500	PK	62.47	28.24	14.23	41.62	2.04	65.36	73.9	8.5	149	103	-
Vert.	4924.000	PK	50.09	31.82	6.52	42.90	2.04	47.57	73.9	26.3	153	342	-
Vert.	7386.000	PK	48.94	37.49	8.00	43.28	2.04	53.19	73.9	20.7	100	0	-
Vert.	9848.000	PK	49.18	39.33	9.24	42.92	2.04	56.87	73.9	17.0	119	0	-
Vert.	2483.500	AV	47.84	28.24	14.23	41.62	2.04	50.73	53.9	3.1	149	103	VBW: 1 kHz
Vert.	4924.000	AV	39.93	31.82	6.52	42.90	2.04	37.41	53.9	16.4	153	342	VBW: 1 kHz
Vert.	7386.000	AV	37.15	37.49	8.00	43.28	2.04	41.40	53.9	12.5	100	0	VBW: 1 kHz
Vert.	9848.000	AV	36.72	39.33	9.24	42.92	2.04	44.41	53.9	9.4	119	0	VBW: 1 kHz

Result = Reading + Ant.Fac. + Loss (Cable+(Attenuator or Filter)(below 18 GHz)) - Gain(Amplifier) + Distance factor

Distance factor : 1 GHz - 13 GHz :  $20 \log (3.79 \text{ m} / 3.0 \text{ m}) = 2.04 \text{ dB}$

13 GHz - 40 GHz :  $20 \log (1.0 \text{ m} / 3.0 \text{ m}) = -9.54 \text{ dB}$

**UL Japan, Inc.**

**Shonan EMC Lab.**

1-22-3 Megumigaoka, Hiratsuka-shi, Kanagawa-ken, 259-1220 JAPAN

Telephone : +81 463 50 6400

Facsimile : +81 463 50 6401



**Radiated Spurious Emission**  
**(Reference Plot for band-edge)**

Report No.	13004393S-A-R2
Test place	Shonan EMC Lab.
Semi Anechoic Chamber	No.3
Date	September 8, 2019
Temperature / Humidity	23 deg.C / 62 %RH
Engineer	Kenichi Adachi
	(1 GHz – 2.8 GHz)
Mode	Tx 11n-20 MIMO, high power, 2462 MHz
EUT Serial No.	B-2
Antenna	Chain-0: Dual Monopole Antenna
	Chain-1: Slot Antenna

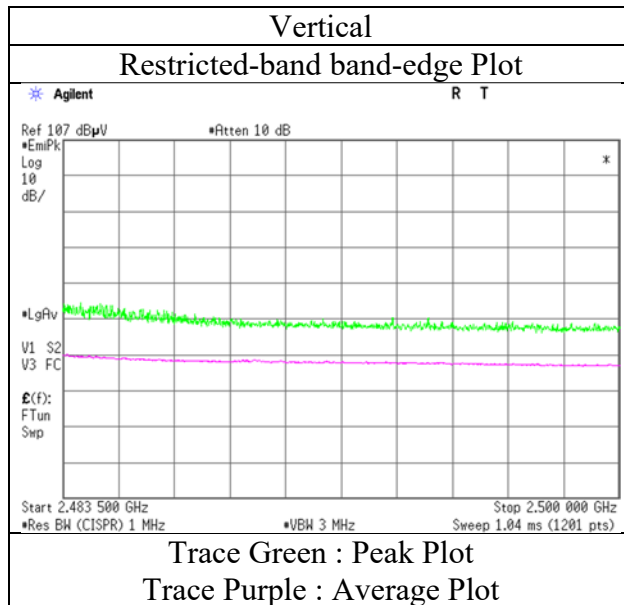
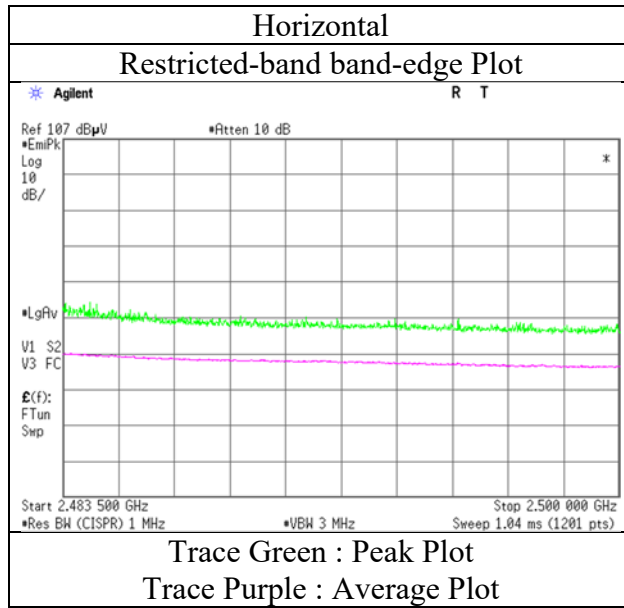

\* The measurement was conducted for a sufficiently long enough time to detect any possible spurious emissions. Final result of restricted band edge was shown in tabular data.

## Radiated Spurious Emission

Report No.	13004393S-A-R2		
Test place	Shonan EMC Lab.		
Semi Anechoic Chamber	No.3	No.3	No.3
Date	September 8, 2019	September 10, 2019	September 13, 2019
Temperature / Humidity	23 deg.C / 62 %RH	23 deg.C / 58 %RH	23 deg.C / 52 %RH
Engineer	Kenichi Adachi	Takahiro Kawakami	Kazuya Noda
	(1 GHz – 2.8 GHz)	(2.8 GHz – 13 GHz)	(13 GHz – 26.5 GHz)
Mode	Tx, 11b, high power, 2412 MHz		
EUT Serial No.	B-2		
Antenna	Chain-0: Dual Monopole Antenna		
	Chain-1: Monopole Antenna		

(\* PK: Peak, AV: Average, QP: Quasi-Peak)

Polarity	Frequency [MHz]	Detector	Reading [dBuV]	Ant.Fac. [dB/m]	Loss [dB]	Gain [dB]	Distance Factor [dB]	Result [dBuV/m]	Limit [dBuV/m]	Margin [dB]	Height [cm]	Angle [deg]	Remark
Hori.	2390.000	PK	52.48	28.33	14.15	41.59	2.15	55.52	73.9	18.3	144	73	-
Hori.	4824.000	PK	49.87	31.64	6.46	42.88	2.15	47.24	73.9	26.6	157	78	-
Hori.	7236.000	PK	49.07	37.25	7.89	42.98	2.15	53.38	73.9	20.5	100	0	-
Hori.	9648.000	PK	48.55	38.97	9.18	43.13	2.15	55.72	73.9	18.1	100	54	-
Hori.	2390.000	AV	40.75	28.33	14.15	41.59	2.15	43.79	53.9	10.1	144	73	VBW: 30 Hz
Hori.	4824.000	AV	38.44	31.64	6.46	42.88	2.15	35.81	53.9	18.0	157	78	VBW: 30 Hz
Hori.	7236.000	AV	36.46	37.25	7.89	42.98	2.15	40.77	53.9	13.1	100	0	VBW: 30 Hz
Hori.	9648.000	AV	37.19	38.97	9.18	43.13	2.15	44.36	53.9	9.5	100	54	VBW: 30 Hz
Vert.	2390.000	PK	50.94	28.33	14.15	41.59	2.15	53.98	73.9	19.9	159	120	-
Vert.	4824.000	PK	49.53	31.64	6.46	42.88	2.15	46.90	73.9	27.0	151	106	-
Vert.	7236.000	PK	48.05	37.25	7.89	42.98	2.15	52.36	73.9	21.5	140	78	-
Vert.	9648.000	PK	48.76	38.97	9.18	43.13	2.15	55.93	73.9	17.9	100	0	-
Vert.	2390.000	AV	39.74	28.33	14.15	41.59	2.15	42.78	53.9	11.1	159	120	VBW: 30 Hz
Vert.	4824.000	AV	38.19	31.64	6.46	42.88	2.15	35.56	53.9	18.3	151	106	VBW: 30 Hz
Vert.	7236.000	AV	36.46	37.25	7.89	42.98	2.15	40.77	53.9	13.1	140	78	VBW: 30 Hz
Vert.	9648.000	AV	37.09	38.97	9.18	43.13	2.15	44.26	53.9	9.6	100	0	VBW: 30 Hz

Result = Reading + Ant.Fac. + Loss (Cable+(Attenuator or Filter)(below 18 GHz)) - Gain(Amplifier) + Distance factor

Distance factor : 1 GHz - 13 GHz :  $20 \log(3.84 \text{ m} / 3.0 \text{ m}) = 2.15 \text{ dB}$

13 GHz - 40 GHz :  $20 \log(1.0 \text{ m} / 3.0 \text{ m}) = -9.54 \text{ dB}$

### 20 dBc Data Sheet (RBW 100 kHz, VBW 300 kHz)

Polarity	Frequency [MHz]	Detector	Reading [dBuV]	Ant.Fac. [dB/m]	Loss [dB]	Gain [dB]	Distance Factor [dB]	Result [dBuV/m]	Limit [dBuV/m]	Margin [dB]	Remark
Hori.	2412.000	PK	104.74	28.29	14.16	41.60	2.15	107.74	-	-	Carrier
Hori.	2400.000	PK	46.54	28.31	14.15	41.60	2.15	49.55	87.74	38.10	-
Vert.	2412.000	PK	101.29	28.29	14.16	41.60	2.15	104.29	-	-	Carrier
Vert.	2400.000	PK	44.31	28.31	14.15	41.60	2.15	47.32	84.29	36.90	-

Result = Reading + Ant.Fac. + Loss (Cable+(Attenuator or Filter)(below 18 GHz)) - Gain(Amplifier) + Distance factor

Distance factor : 1 GHz - 13 GHz :  $20 \log(3.84 \text{ m} / 3.0 \text{ m}) = 2.15 \text{ dB}$

13 GHz - 40 GHz :  $20 \log(1.0 \text{ m} / 3.0 \text{ m}) = -9.54 \text{ dB}$

**UL Japan, Inc.**

**Shonan EMC Lab.**

1-22-3 Megumigaoka, Hiratsuka-shi, Kanagawa-ken, 259-1220 JAPAN

Telephone : +81 463 50 6400

Facsimile : +81 463 50 6401

**Radiated Spurious Emission**  
**(Reference Plot for band-edge)**

Report No.	13004393S-A-R2
Test place	Shonan EMC Lab.
Semi Anechoic Chamber	No.3
Date	September 8, 2019
Temperature / Humidity	23 deg.C / 62 %RH
Engineer	Kenichi Adachi
	(1 GHz – 2.8 GHz)
Mode	Tx, 11b, high power, 2412 MHz
EUT Serial No.	B-2
Antenna	Chain-0: Dual Monopole Antenna Chain-1: Monopole Antenna

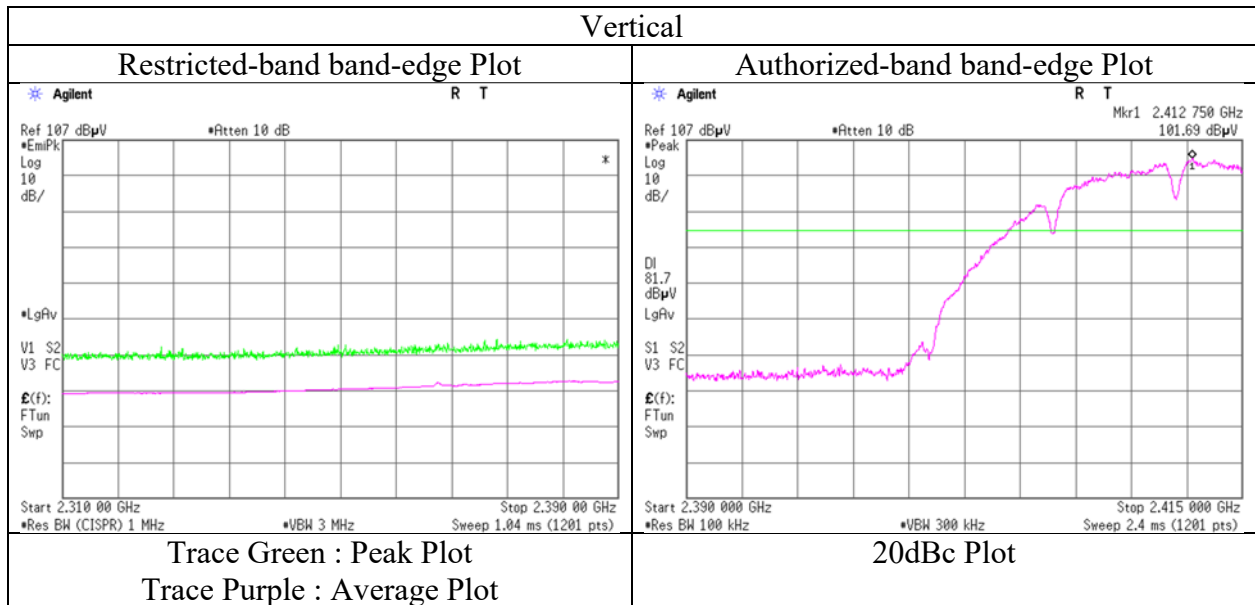
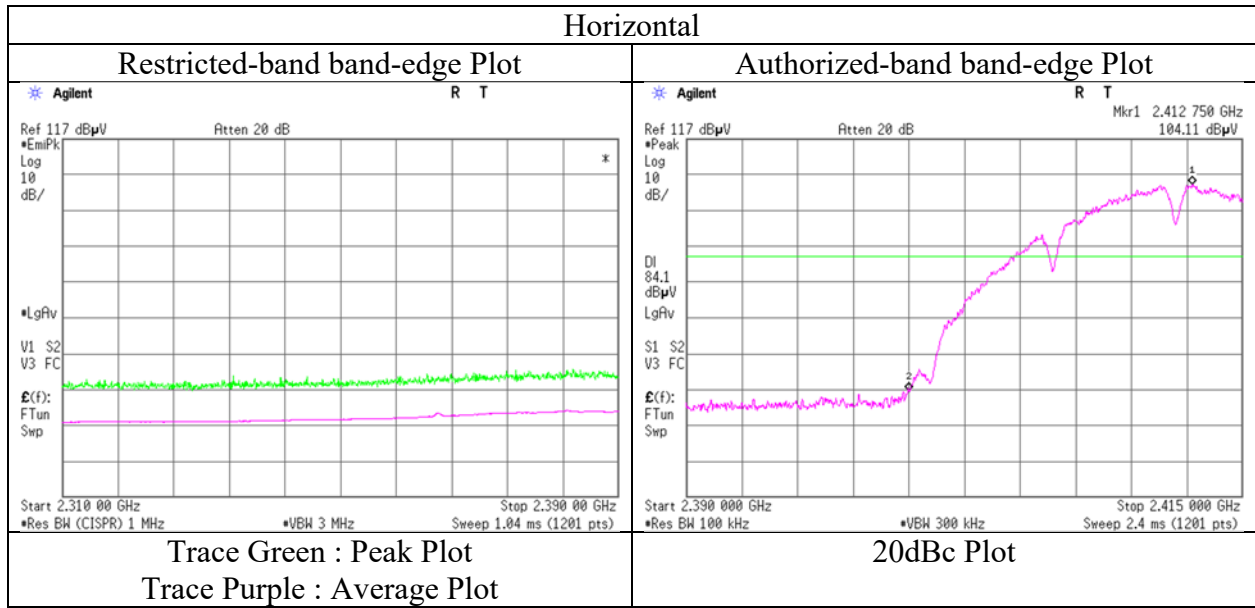

\* The measurement was conducted for a sufficiently long enough time to detect any possible spurious emissions. Final result of restricted band edge was shown in tabular data.

## Radiated Spurious Emission

Report No. 13004393S-A-R2  
Test place Shonan EMC Lab.  
Semi Anechoic Chamber No.3 No.3  
Date September 10, 2019 September 13, 2019  
Temperature / Humidity 23 deg.C / 58 %RH 23 deg.C / 52 %RH  
Engineer Takahiro Kawakami Kazuya Noda  
(1 GHz – 13 GHz) (13 GHz – 26.5 GHz)  
Mode Tx 11b, high power, 2437 MHz  
EUT Serial No. B-2  
Antenna Chain-0: Dual Monopole Antenna  
Chain-1: Monopole Antenna

(\* PK: Peak, AV: Average, QP: Quasi-Peak)

Polarity	Frequency [MHz]	Detector	Reading [dBuV]	Ant.Fac. [dB/m]	Loss [dB]	Gain [dB]	Distance Factor [dB]	Result [dBuV/m]	Limit [dBuV/m]	Margin [dB]	Height [cm]	Angle [deg]	Remark
Hori.	4874.000	PK	50.64	31.70	6.49	42.89	2.15	48.09	73.9	25.8	142	284	-
Hori.	7311.000	PK	49.81	37.36	7.95	43.13	2.15	54.14	73.9	19.7	100	0	-
Hori.	9748.000	PK	48.85	39.31	9.21	43.02	2.15	56.50	73.9	17.4	100	0	-
Hori.	4874.000	AV	39.84	31.70	6.49	42.89	2.15	37.29	53.9	16.6	142	284	VBW: 30 Hz
Hori.	7311.000	AV	36.49	37.36	7.95	43.13	2.15	40.82	53.9	13.0	100	0	VBW: 30 Hz
Hori.	9748.000	AV	36.84	39.31	9.21	43.02	2.15	44.49	53.9	9.4	100	0	VBW: 30 Hz
Vert.	4874.000	PK	50.55	31.70	6.49	42.89	2.15	48.00	73.9	25.9	144	6	-
Vert.	7311.000	PK	49.17	37.36	7.95	43.13	2.15	53.50	73.9	20.4	100	0	-
Vert.	9748.000	PK	49.11	39.31	9.21	43.02	2.15	56.76	73.9	17.1	130	0	-
Vert.	4874.000	AV	39.43	31.70	6.49	42.89	2.15	36.88	53.9	17.0	144	6	VBW: 30 Hz
Vert.	7311.000	AV	36.46	37.36	7.95	43.13	2.15	40.79	53.9	13.1	100	0	VBW: 30 Hz
Vert.	9748.000	AV	36.54	39.31	9.21	43.02	2.15	44.19	53.9	9.7	130	0	VBW: 30 Hz

Result = Reading + Ant.Fac. + Loss (Cable+(Attenuator or Filter)(below 18 GHz)) - Gain(Amplifier) + Distance factor

Distance factor : 1 GHz - 13 GHz :  $20 \log (3.84 \text{ m} / 3.0 \text{ m}) = 2.15 \text{ dB}$

13 GHz - 40 GHz :  $20 \log (1.0 \text{ m} / 3.0 \text{ m}) = -9.54 \text{ dB}$

**UL Japan, Inc.**

**Shonan EMC Lab.**

1-22-3 Megumigaoka, Hiratsuka-shi, Kanagawa-ken, 259-1220 JAPAN

Telephone : +81 463 50 6400

Facsimile : +81 463 50 6401

## Radiated Spurious Emission

Report No.	13004393S-A-R2		
Test place	Shonan EMC Lab.		
Semi Anechoic Chamber	No.3	No.3	No.3
Date	September 8, 2019	September 10, 2019	September 13, 2019
Temperature / Humidity	23 deg.C / 62 %RH	23 deg.C / 58 %RH	23 deg.C / 52 %RH
Engineer	Kenichi Adachi	Takahiro Kawakami	Kazuya Noda
	(1 GHz – 2.8 GHz)	(2.8 GHz – 13 GHz)	(13 GHz – 26.5 GHz)
Mode	Tx 11b, high power, 2462 MHz		
EUT Serial No.	B-2		
Antenna	Chain-0: Dual Monopole Antenna		
	Chain-1: Monopole Antenna		

(\* PK: Peak, AV: Average, QP: Quasi-Peak)

Polarity	Frequency [MHz]	Detector	Reading [dBuV]	Ant.Fac. [dB/m]	Loss [dB]	Gain [dB]	Distance Factor [dB]	Result [dBuV/m]	Limit [dBuV/m]	Margin [dB]	Height [cm]	Angle [deg]	Remark
Hori.	2483.500	PK	52.28	28.24	14.23	41.62	2.15	55.28	73.9	18.6	142	76	-
Hori.	4924.000	PK	50.20	31.82	6.52	42.90	2.15	47.79	73.9	26.1	133	60	-
Hori.	7386.000	PK	49.57	37.49	8.00	43.28	2.15	53.93	73.9	19.9	100	0	-
Hori.	9848.000	PK	48.61	39.33	9.24	42.92	2.15	56.41	73.9	17.4	134	354	-
Hori.	2483.500	AV	40.22	28.24	14.23	41.62	2.15	43.22	53.9	10.6	142	76	VBW: 30 Hz
Hori.	4924.000	AV	39.62	31.82	6.52	42.90	2.15	37.21	53.9	16.6	133	60	VBW: 30 Hz
Hori.	7386.000	AV	36.69	37.49	8.00	43.28	2.15	41.05	53.9	12.8	100	0	VBW: 30 Hz
Hori.	9848.000	AV	36.17	39.33	9.24	42.92	2.15	43.97	53.9	9.9	134	354	VBW: 30 Hz
Vert.	2483.500	PK	51.24	28.24	14.23	41.62	2.15	54.24	73.9	19.6	151	134	-
Vert.	4924.000	PK	50.05	31.82	6.52	42.90	2.15	47.64	73.9	26.2	160	29	-
Vert.	7386.000	PK	48.75	37.49	8.00	43.28	2.15	53.11	73.9	20.7	133	0	-
Vert.	9848.000	PK	48.19	39.33	9.24	42.92	2.15	55.99	73.9	17.9	100	0	-
Vert.	2483.500	AV	39.59	28.24	14.23	41.62	2.15	42.59	53.9	11.3	151	134	VBW: 30 Hz
Vert.	4924.000	AV	39.15	31.82	6.52	42.90	2.15	36.74	53.9	17.1	160	29	VBW: 30 Hz
Vert.	7386.000	AV	36.65	37.49	8.00	43.28	2.15	41.01	53.9	12.8	133	0	VBW: 30 Hz
Vert.	9848.000	AV	36.33	39.33	9.24	42.92	2.15	44.13	53.9	9.7	100	0	VBW: 30 Hz

Result = Reading + Ant.Fac. + Loss (Cable+(Attenuator or Filter)(below 18 GHz)) - Gain(Amplifier) + Distance factor

Distance factor : 1 GHz - 13 GHz :  $20 \log(3.84 \text{ m} / 3.0 \text{ m}) = 2.15 \text{ dB}$

13 GHz - 40 GHz :  $20 \log(1.0 \text{ m} / 3.0 \text{ m}) = -9.54 \text{ dB}$

**UL Japan, Inc.**

**Shonan EMC Lab.**

1-22-3 Megumigaoka, Hiratsuka-shi, Kanagawa-ken, 259-1220 JAPAN

Telephone : +81 463 50 6400

Facsimile : +81 463 50 6401

**Radiated Spurious Emission**  
**(Reference Plot for band-edge)**

Report No.	13004393S-A-R2
Test place	Shonan EMC Lab.
Semi Anechoic Chamber	No.3
Date	September 8, 2019
Temperature / Humidity	23 deg.C / 62 %RH
Engineer	Kenichi Adachi
	(1 GHz – 2.8 GHz)
Mode	Tx 11b, high power, 2462 MHz
EUT Serial No.	B-2
Antenna	Chain-0: Dual Monopole Antenna
	Chain-1: Monopole Antenna

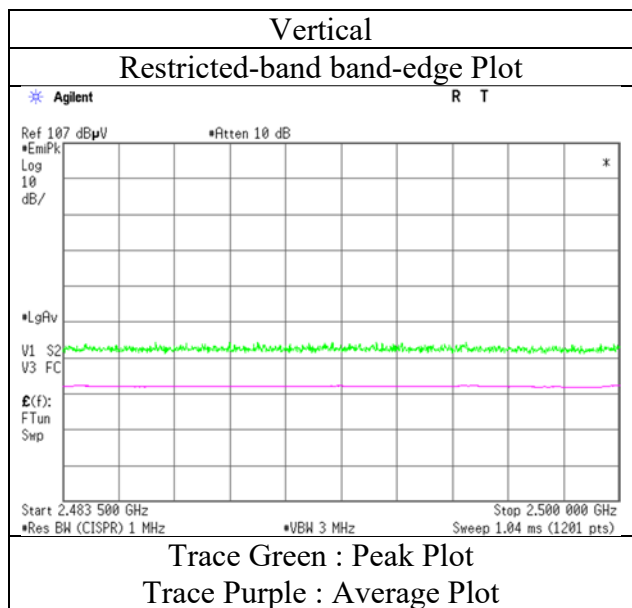
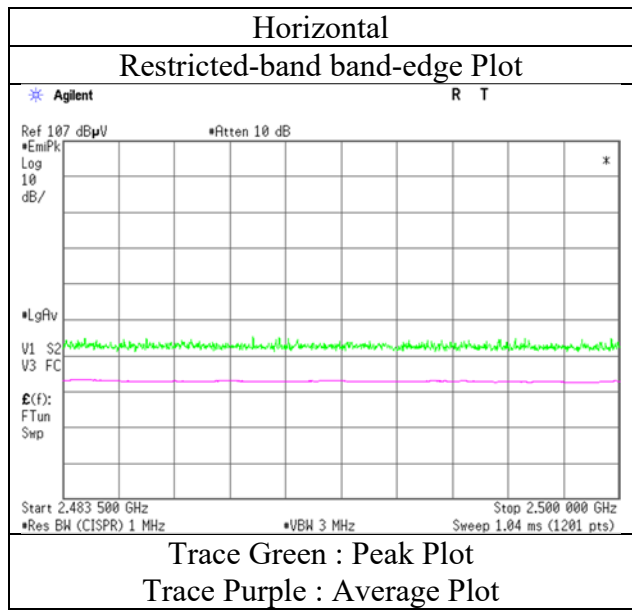

\* The measurement was conducted for a sufficiently long enough time to detect any possible spurious emissions. Final result of restricted band edge was shown in tabular data.

## Radiated Spurious Emission

Report No.	13004393S-A-R2			
Test place	Shonan EMC Lab.			
Semi Anechoic Chamber	No.3	No.3	No.3	No.3
Date	September 17, 2019	September 8, 2019	September 10, 2019	September 13, 2019
Temperature / Humidity	24 deg.C / 65 %RH	23 deg.C / 62 %RH	23 deg.C / 58 %RH	23 deg.C / 52 %RH
Engineer	Kenichi Adachi	Kenichi Adachi	Takahiro Kawakami	Kazuya Noda
	(30 MHz - 1 GHz)	(1 GHz - 2.8 GHz)	(2.8 GHz - 13 GHz)	(13 GHz - 26.5 GHz)
Mode	Tx 11g, high power, 2412 MHz			
EUT Serial No.	B-2			
Antenna	Chain-0: Dual Monopole Antenna Chain-1: Monopole Antenna			

(\* PK: Peak, AV: Average, QP: Quasi-Peak)

Polarity	Frequency [MHz]	Detector	Reading [dBuV]	Ant.Fac. [dB/m]	Loss [dB]	Gain [dB]	Distance Factor [dB]	Result [dBuV/m]	Limit [dBuV/m]	Margin [dB]	Height [cm]	Angle [deg]	Remark
Hori.	67.883	QP	34.78	6.67	6.67	32.18	0.00	15.94	40.0	24.0	271	281	-
Hori.	107.662	QP	33.36	11.41	7.30	32.15	0.00	19.92	43.5	23.5	296	273	-
Hori.	161.286	QP	33.84	15.12	7.91	32.11	0.00	24.76	43.5	18.7	196	117	-
Hori.	239.996	QP	43.14	11.31	8.35	32.02	0.00	30.78	46.0	15.2	129	114	-
Hori.	701.995	QP	33.25	19.37	10.38	31.86	0.00	31.14	46.0	14.8	146	303	-
Hori.	2390.000	PK	63.73	28.33	14.15	41.59	2.15	66.77	73.9	7.1	144	80	-
Hori.	4824.000	PK	49.08	31.64	6.46	42.88	2.15	46.45	73.9	27.4	149	354	-
Hori.	7236.000	PK	48.86	37.25	7.89	42.98	2.15	53.17	73.9	20.7	100	0	-
Hori.	9648.000	PK	48.74	38.97	9.18	43.13	2.15	55.91	73.9	17.9	100	0	-
Hori.	2390.000	AV	47.31	28.33	14.15	41.59	2.15	50.35	53.9	3.5	144	80	VBW: 300 Hz
Hori.	4824.000	AV	38.47	31.64	6.46	42.88	2.15	35.84	53.9	18.0	149	354	VBW: 300 Hz
Hori.	7236.000	AV	36.90	37.25	7.89	42.98	2.15	41.21	53.9	12.6	100	0	VBW: 300 Hz
Hori.	9648.000	AV	36.76	38.97	9.18	43.13	2.15	43.93	53.9	9.9	100	0	VBW: 300 Hz
Vert.	67.756	QP	44.65	6.68	6.66	32.18	0.00	25.81	40.0	14.1	100	207	-
Vert.	107.243	QP	40.76	11.33	7.30	32.15	0.00	27.24	43.5	16.2	100	317	-
Vert.	161.280	QP	36.06	15.12	7.91	32.11	0.00	26.98	43.5	16.5	100	264	-
Vert.	239.996	QP	37.24	11.31	8.35	32.02	0.00	24.88	46.0	21.1	100	277	-
Vert.	731.995	QP	33.98	19.89	10.48	31.81	0.00	32.54	46.0	13.4	100	96	-
Vert.	2390.000	PK	63.34	28.33	14.15	41.59	2.15	66.38	73.9	7.5	135	104	-
Vert.	4824.000	PK	48.64	31.64	6.46	42.88	2.15	46.01	73.9	27.8	136	0	-
Vert.	7236.000	PK	47.92	37.25	7.89	42.98	2.15	52.23	73.9	21.6	100	0	-
Vert.	9648.000	PK	47.76	38.97	9.18	43.13	2.15	54.93	73.9	18.9	100	0	-
Vert.	2390.000	AV	47.01	28.33	14.15	41.59	2.15	50.05	53.9	3.8	135	104	VBW: 300 Hz
Vert.	4824.000	AV	36.97	31.64	6.46	42.88	2.15	34.34	53.9	19.5	136	0	VBW: 300 Hz
Vert.	7236.000	AV	36.82	37.25	7.89	42.98	2.15	41.13	53.9	12.7	100	0	VBW: 300 Hz
Vert.	9648.000	AV	37.09	38.97	9.18	43.13	2.15	44.26	53.9	9.6	100	0	VBW: 300 Hz

Result = Reading + Ant.Fac. + Loss (Cable+(Attenuator or Filter)(below 18 GHz)) - Gain(Amplifier) + Distance factor

Distance factor : 1 GHz - 13 GHz : 20 log ( 3.84 m / 3.0 m ) = 2.15 dB

13 GHz - 40 GHz : 20log (1.0 m / 3.0 m) = -9.54 dB

### 20 dBc Data Sheet (RBW 100 kHz, VBW 300 kHz)

Polarity	Frequency [MHz]	Detector	Reading [dBuV]	Ant.Fac. [dB/m]	Loss [dB]	Gain [dB]	Distance Factor [dB]	Result [dBuV/m]	Limit [dBuV/m]	Margin [dB]	Remark
Hori.	2412.000	PK	97.74	28.29	14.16	41.60	2.15	100.74	-	-	Carrier
Hori.	2400.000	PK	62.77	28.31	14.15	41.60	2.15	65.78	80.74	14.90	-
Vert.	2412.000	PK	97.81	28.29	14.16	41.60	2.15	100.81	-	-	Carrier
Vert.	2400.000	PK	61.58	28.31	14.15	41.60	2.15	64.59	80.81	16.20	-

Result = Reading + Ant.Fac. + Loss (Cable+(Attenuator or Filter)(below 18 GHz)) - Gain(Amplifier) + Distance factor

Distance factor : 1 GHz - 13 GHz : 20 log ( 3.84 m / 3.0 m ) = 2.15 dB

13 GHz - 40 GHz : 20log (1.0 m / 3.0 m) = -9.54 dB

**UL Japan, Inc.**

**Shonan EMC Lab.**

1-22-3 Megumigaoka, Hiratsuka-shi, Kanagawa-ken, 259-1220 JAPAN

Telephone : +81 463 50 6400

Facsimile : +81 463 50 6401

**Radiated Spurious Emission**  
**(Reference Plot for band-edge)**

Report No. 13004393S-A-R2  
Test place Shonan EMC Lab.  
Semi Anechoic Chamber No.3  
Date September 8, 2019  
Temperature / Humidity 23 deg.C / 62 %RH  
Engineer Kenichi Adachi  
(1 GHz – 2.8 GHz)  
Mode Tx 11g, high power, 2412 MHz  
EUT Serial No. B-2  
Antenna Chain-0: Dual Monopole Antenna  
Chain-1: Monopole Antenna

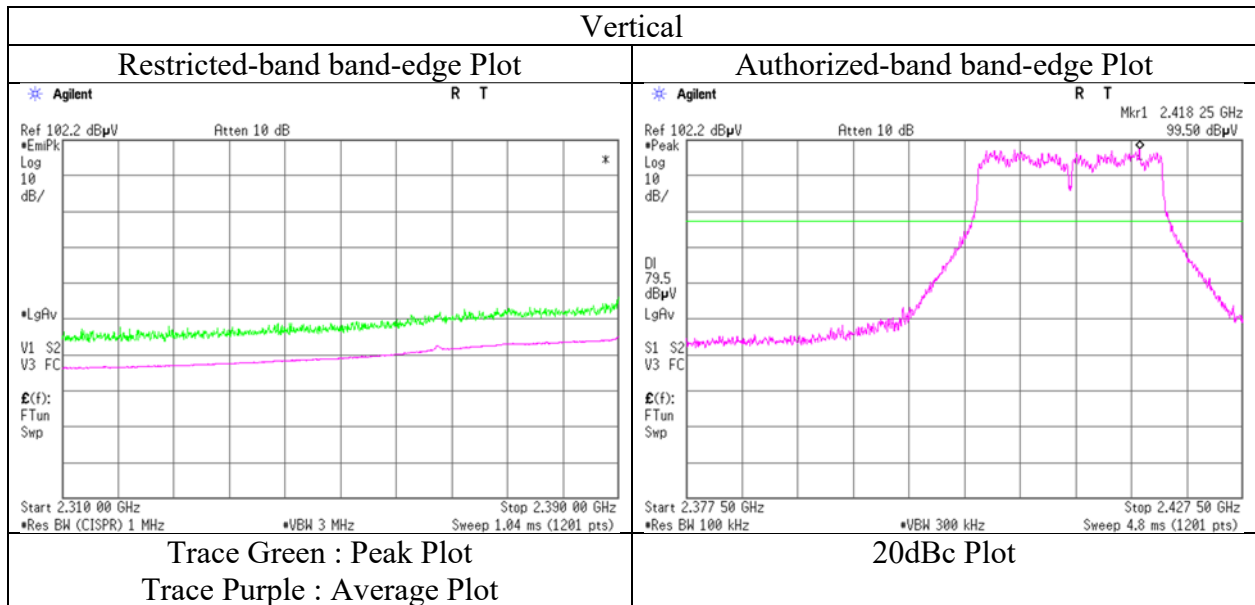
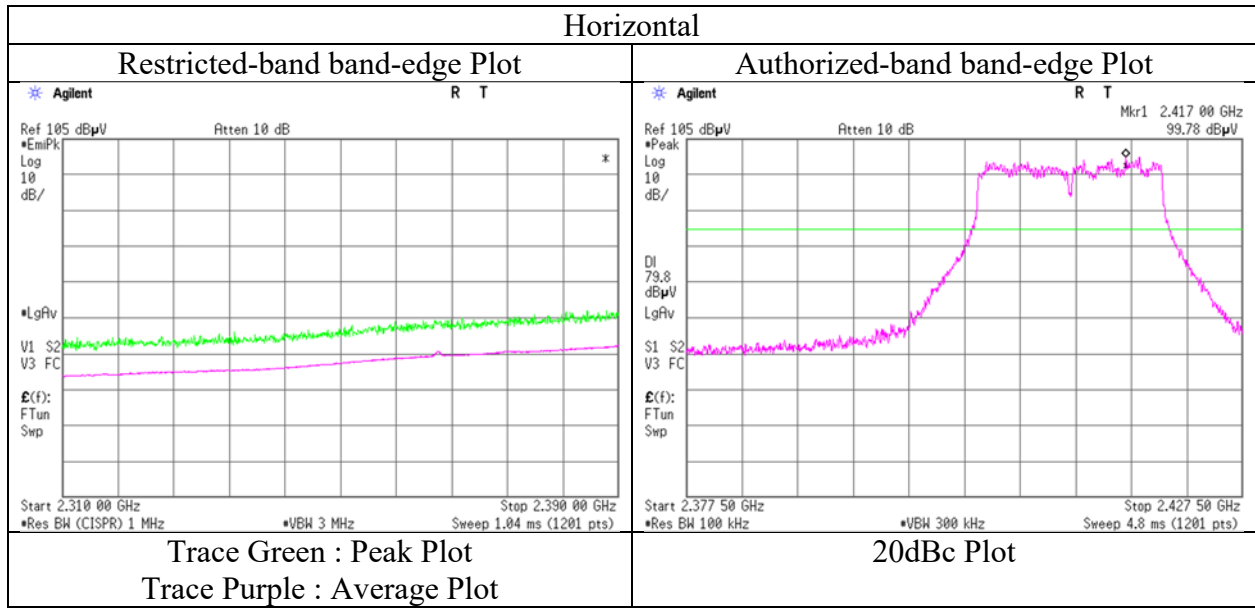

\* The measurement was conducted for a sufficiently long enough time to detect any possible spurious emissions.  
Final result of restricted band edge was shown in tabular data.



## Radiated Spurious Emission

Report No. 13004393S-A-R2  
Test place Shonan EMC Lab.  
Semi Anechoic Chamber No.3 No.3  
Date September 10, 2019 September 13, 2019  
Temperature / Humidity 23 deg.C / 58 %RH 23 deg.C / 52 %RH  
Engineer Takahiro Kawakami Kazuya Noda  
(1 GHz – 13 GHz) (13 GHz – 26.5 GHz)  
Mode Tx 11g, high power, 2437 MHz  
EUT Serial No. A-1  
Antenna Chain-0: Dual Monopole Antenna  
Chain-1: Monopole Antenna

(\* PK: Peak, AV: Average, QP: Quasi-Peak)

Polarity	Frequency [MHz]	Detector	Reading [dBuV]	Ant.Fac. [dB/m]	Loss [dB]	Gain [dB]	Distance Factor [dB]	Result [dBuV/m]	Limit [dBuV/m]	Margin [dB]	Height [cm]	Angle [deg]	Remark
Hori.	4874.000	PK	50.54	31.70	6.49	42.89	2.15	47.99	73.9	25.9	154	335	-
Hori.	7311.000	PK	49.40	37.36	7.95	43.13	2.15	53.73	73.9	20.1	133	22	-
Hori.	9748.000	PK	49.80	39.31	9.21	43.02	2.15	57.45	73.9	16.4	140	0	-
Hori.	4874.000	AV	37.22	31.70	6.49	42.89	2.15	34.67	53.9	19.2	154	335	VBW: 300 Hz
Hori.	7311.000	AV	36.78	37.36	7.95	43.13	2.15	41.11	53.9	12.7	133	22	VBW: 300 Hz
Hori.	9748.000	AV	36.71	39.31	9.21	43.02	2.15	44.36	53.9	9.5	140	0	VBW: 300 Hz
Vert.	4874.000	PK	50.63	31.70	6.49	42.89	2.15	48.08	73.9	25.8	144	0	-
Vert.	7311.000	PK	49.71	37.36	7.95	43.13	2.15	54.04	73.9	19.8	100	0	-
Vert.	9748.000	PK	48.88	39.31	9.21	43.02	2.15	56.53	73.9	17.3	145	0	-
Vert.	4874.000	AV	37.98	31.70	6.49	42.89	2.15	35.43	53.9	18.4	144	0	VBW: 300 Hz
Vert.	7311.000	AV	36.90	37.36	7.95	43.13	2.15	41.23	53.9	12.6	100	0	VBW: 300 Hz
Vert.	9748.000	AV	36.78	39.31	9.21	43.02	2.15	44.43	53.9	9.4	145	0	VBW: 300 Hz

Result = Reading + Ant.Fac. + Loss (Cable+(Attenuator or Filter)(below 18 GHz)) - Gain(Amplifier) + Distance factor

Distance factor : 1 GHz - 13 GHz :  $20 \log(3.84 \text{ m} / 3.0 \text{ m}) = 2.15 \text{ dB}$

13 GHz - 40 GHz :  $20 \log(1.0 \text{ m} / 3.0 \text{ m}) = -9.54 \text{ dB}$

**UL Japan, Inc.**

**Shonan EMC Lab.**

1-22-3 Megumigaoka, Hiratsuka-shi, Kanagawa-ken, 259-1220 JAPAN

Telephone : +81 463 50 6400

Facsimile : +81 463 50 6401

## Radiated Spurious Emission

Report No.	13004393S-A-R2		
Test place	Shonan EMC Lab.		
Semi Anechoic Chamber	No.3	No.3	No.3
Date	September 9, 2019	September 10, 2019	September 13, 2019
Temperature / Humidity	23 deg.C / 62 %RH	23 deg.C / 58 %RH	23 deg.C / 52 %RH
Engineer	Kenichi Adachi	Takahiro Kawakami	Kazuya Noda
	(1 GHz – 2.8 GHz)	(2.8 GHz – 13 GHz)	(13 GHz – 26.5 GHz)
Mode	Tx 11g, high power, 2462 MHz		
EUT Serial No.	B-2		
Antenna	Chain-0: Dual Monopole Antenna		
	Chain-1: Monopole Antenna		

(\* PK: Peak, AV: Average, QP: Quasi-Peak)

Polarity	Frequency [MHz]	Detector	Reading [dBuV]	Ant.Fac. [dB/m]	Loss [dB]	Gain [dB]	Distance Factor [dB]	Result [dBuV/m]	Limit [dBuV/m]	Margin [dB]	Height [cm]	Angle [deg]	Remark
Hori.	2483.500	PK	64.81	28.24	14.23	41.62	2.15	67.81	73.9	6.0	126	86	-
Hori.	4924.000	PK	49.58	31.82	6.52	42.90	2.15	47.17	73.9	26.7	153	9	-
Hori.	7386.000	PK	47.97	37.49	8.00	43.28	2.15	52.33	73.9	21.5	100	0	-
Hori.	9848.000	PK	47.03	39.33	9.24	42.92	2.15	54.83	73.9	19.0	132	38	-
Hori.	2483.500	AV	48.38	28.24	14.23	41.62	2.15	51.38	53.9	2.5	126	86	VBW: 300 Hz
Hori.	4924.000	AV	38.05	31.82	6.52	42.90	2.15	35.64	53.9	18.2	153	9	VBW: 300 Hz
Hori.	7386.000	AV	37.32	37.49	8.00	43.28	2.15	41.68	53.9	12.2	100	0	VBW: 300 Hz
Hori.	9848.000	AV	37.10	39.33	9.24	42.92	2.15	44.90	53.9	9.0	132	38	VBW: 300 Hz
Vert.	2483.500	PK	63.88	28.24	14.23	41.62	2.15	66.88	73.9	7.0	130	109	-
Vert.	4924.000	PK	49.62	31.82	6.52	42.90	2.15	47.21	73.9	26.6	125	338	-
Vert.	7386.000	PK	48.12	37.49	8.00	43.28	2.15	52.48	73.9	21.4	100	0	-
Vert.	9848.000	PK	48.38	39.33	9.24	42.92	2.15	56.18	73.9	17.7	100	0	-
Vert.	2483.500	AV	47.74	28.24	14.23	41.62	2.15	50.74	53.9	3.1	130	109	VBW: 300 Hz
Vert.	4924.000	AV	37.47	31.82	6.52	42.90	2.15	35.06	53.9	18.8	125	338	VBW: 300 Hz
Vert.	7386.000	AV	36.99	37.49	8.00	43.28	2.15	41.35	53.9	12.5	100	0	VBW: 300 Hz
Vert.	9848.000	AV	36.52	39.33	9.24	42.92	2.15	44.32	53.9	9.5	100	0	VBW: 300 Hz

Result = Reading + Ant.Fac. + Loss (Cable+(Attenuator or Filter)(below 18 GHz)) - Gain(Amplifier) + Distance factor

Distance factor : 1 GHz - 13 GHz :  $20 \log(3.84 \text{ m} / 3.0 \text{ m}) = 2.15 \text{ dB}$

13 GHz - 40 GHz :  $20 \log(1.0 \text{ m} / 3.0 \text{ m}) = -9.54 \text{ dB}$

**UL Japan, Inc.**

**Shonan EMC Lab.**

1-22-3 Megumigaoka, Hiratsuka-shi, Kanagawa-ken, 259-1220 JAPAN

Telephone : +81 463 50 6400

Facsimile : +81 463 50 6401

**Radiated Spurious Emission**  
**(Reference Plot for band-edge)**

Report No.	13004393S-A-R2
Test place	Shonan EMC Lab.
Semi Anechoic Chamber	No.3
Date	September 9, 2019
Temperature / Humidity	23 deg.C / 62 %RH
Engineer	Kenichi Adachi
	(1 GHz – 2.8 GHz)
Mode	Tx 11g, high power, 2462 MHz
EUT Serial No.	B-2
Antenna	Chain-0: Dual Monopole Antenna
	Chain-1: Monopole Antenna

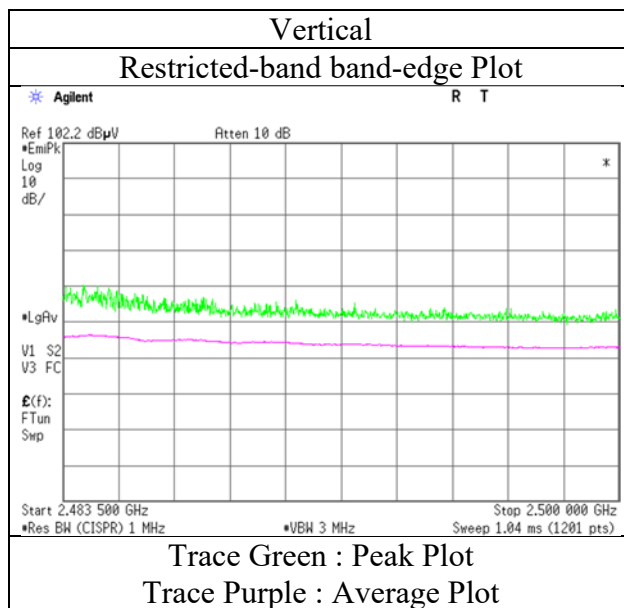
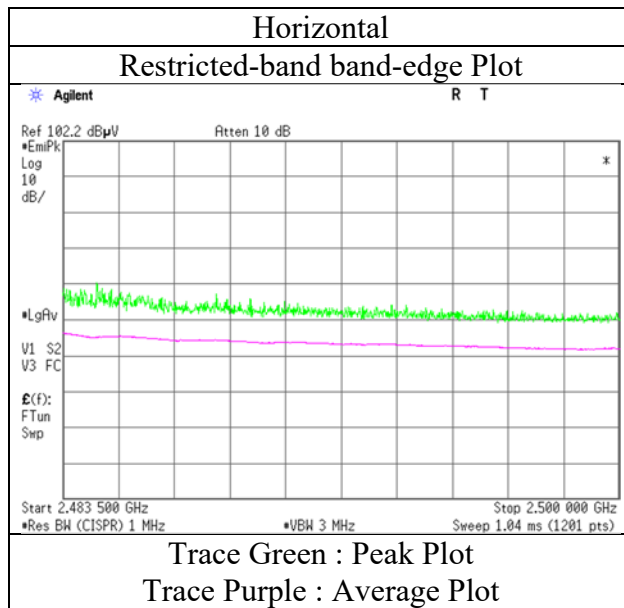

\* The measurement was conducted for a sufficiently long enough time to detect any possible spurious emissions. Final result of restricted band edge was shown in tabular data.

## Radiated Spurious Emission

Report No.	13004393S-A-R2		
Test place	Shonan EMC Lab.		
Semi Anechoic Chamber	No.3	No.3	No.3
Date	September 8, 2019	September 10, 2019	September 13, 2019
Temperature / Humidity	23 deg.C / 62 %RH	23 deg.C / 55 %RH	23 deg.C / 52 %RH
Engineer	Kenichi Adachi	Kazuya Noda	Kazuya Noda
	(1 GHz – 2.8 GHz)	(2.8 GHz – 13 GHz)	(13 GHz – 26.5 GHz)
Mode	Tx 11n-20 MIMO, high power, 2412 MHz		
EUT Serial No.	B-2		
Antenna	Chain-0: Dual Monopole Antenna Chain-1: Monopole Antenna		

(\* PK: Peak, AV: Average, QP: Quasi-Peak)

Polarity	Frequency [MHz]	Detector	Reading [dBuV]	Ant.Fac. [dB/m]	Loss [dB]	Gain [dB]	Distance Factor [dB]	Result [dBuV/m]	Limit [dBuV/m]	Margin [dB]	Height [cm]	Angle [deg]	Remark
Hori.	2390.000	PK	67.32	28.33	14.15	41.59	2.15	70.36	73.9	3.5	145	71	-
Hori.	4824.000	PK	49.37	31.64	6.46	42.88	2.15	46.74	73.9	27.1	299	71	-
Hori.	7236.000	PK	47.92	37.25	7.89	42.98	2.15	52.23	73.9	21.6	100	0	-
Hori.	9648.000	PK	49.21	38.97	9.18	43.13	2.15	56.38	73.9	17.5	132	80	-
Hori.	2390.000	AV	45.06	28.33	14.15	41.59	2.15	48.10	53.9	5.8	145	71	VBW: 1 kHz
Hori.	4824.000	AV	38.38	31.64	6.46	42.88	2.15	35.75	53.9	18.1	299	71	VBW: 1 kHz
Hori.	7236.000	AV	37.34	37.25	7.89	42.98	2.15	41.65	53.9	12.2	100	0	VBW: 1 kHz
Hori.	9648.000	AV	37.91	38.97	9.18	43.13	2.15	45.08	53.9	8.8	132	80	VBW: 1 kHz
Vert.	2390.000	PK	66.05	28.33	14.15	41.59	2.15	69.09	73.9	4.8	158	121	-
Vert.	4824.000	PK	49.41	31.64	6.46	42.88	2.15	46.78	73.9	27.1	109	295	-
Vert.	7236.000	PK	48.56	37.25	7.89	42.98	2.15	52.87	73.9	21.0	100	0	-
Vert.	9648.000	PK	49.33	38.97	9.18	43.13	2.15	56.50	73.9	17.4	129	92	-
Vert.	2390.000	AV	44.96	28.33	14.15	41.59	2.15	48.00	53.9	5.9	158	121	VBW: 1 kHz
Vert.	4824.000	AV	38.79	31.64	6.46	42.88	2.15	36.16	53.9	17.7	109	295	VBW: 1 kHz
Vert.	7236.000	AV	37.39	37.25	7.89	42.98	2.15	41.70	53.9	12.2	100	0	VBW: 1 kHz
Vert.	9648.000	AV	38.29	38.97	9.18	43.13	2.15	45.46	53.9	8.4	129	92	VBW: 1 kHz

Result = Reading + Ant.Fac. + Loss (Cable+(Attenuator or Filter)(below 18 GHz)) - Gain(Amplifier) + Distance factor

Distance factor : 1 GHz - 13 GHz :  $20 \log(3.84 \text{ m} / 3.0 \text{ m}) = 2.15 \text{ dB}$

13 GHz - 40 GHz :  $20 \log(1.0 \text{ m} / 3.0 \text{ m}) = -9.54 \text{ dB}$

### 20 dBc Data Sheet (RBW 100 kHz, VBW 300 kHz)

Polarity	Frequency [MHz]	Detector	Reading [dBuV]	Ant.Fac. [dB/m]	Loss [dB]	Gain [dB]	Distance Factor [dB]	Result [dBuV/m]	Limit [dBuV/m]	Margin [dB]	Remark
Hori.	2412.000	PK	99.87	28.29	14.16	41.60	2.15	102.87	-	-	Carrier
Hori.	2400.000	PK	71.48	28.31	14.15	41.60	2.15	74.49	82.87	8.30	-
Vert.	2412.000	PK	98.34	28.29	14.16	41.60	2.15	101.34	-	-	Carrier
Vert.	2400.000	PK	61.71	28.31	14.15	41.60	2.15	64.72	81.34	16.60	-

Result = Reading + Ant.Fac. + Loss (Cable+(Attenuator or Filter)(below 18 GHz)) - Gain(Amplifier) + Distance factor

Distance factor : 1 GHz - 13 GHz :  $20 \log(3.84 \text{ m} / 3.0 \text{ m}) = 2.15 \text{ dB}$

13 GHz - 40 GHz :  $20 \log(1.0 \text{ m} / 3.0 \text{ m}) = -9.54 \text{ dB}$

**Radiated Spurious Emission**  
**(Reference Plot for band-edge)**

Report No. 13004393S-A-R2  
Test place Shonan EMC Lab.  
Semi Anechoic Chamber No.3  
Date September 8, 2019  
Temperature / Humidity 23 deg.C / 62 %RH  
Engineer Kenichi Adachi  
(1 GHz – 2.8 GHz)  
Mode Tx 11n-20 MIMO, high power, 2412 MHz  
EUT Serial No. B-2  
Antenna Chain-0: Dual Monopole Antenna  
Chain-1: Monopole Antenna

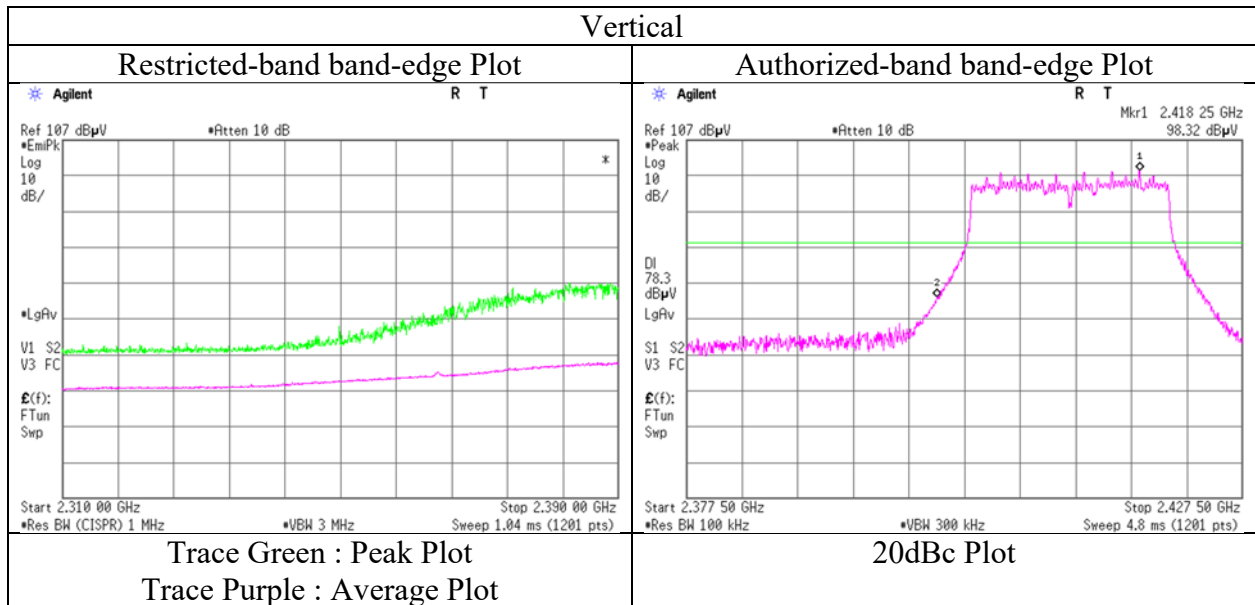
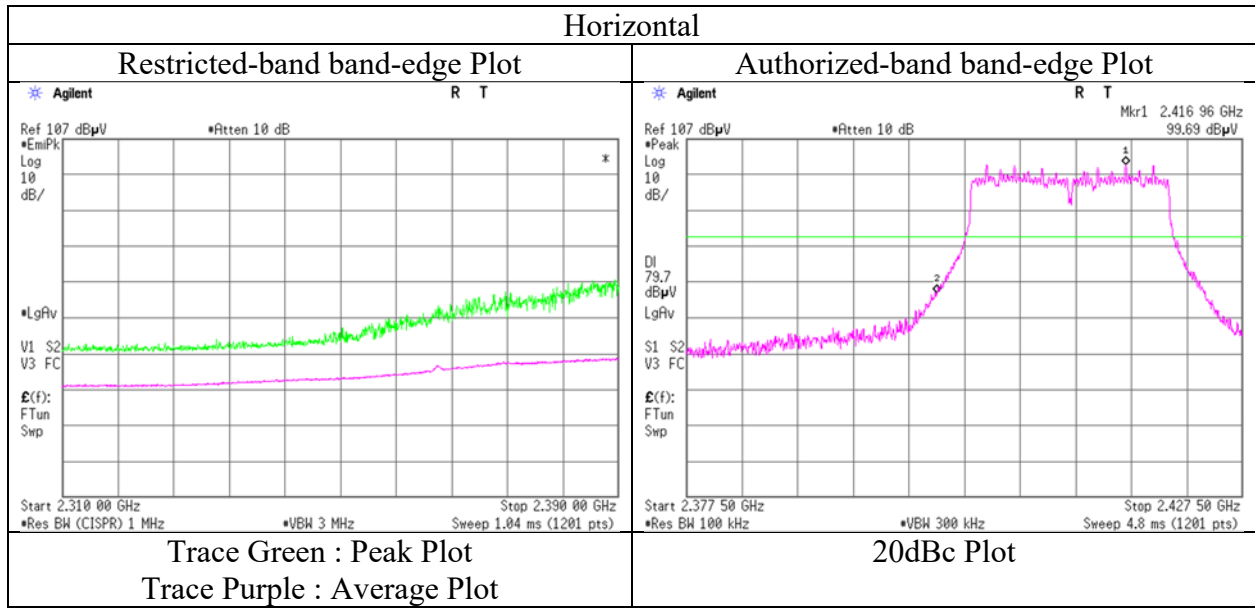

\* The measurement was conducted for a sufficiently long enough time to detect any possible spurious emissions.  
Final result of restricted band edge was shown in tabular data.

**UL Japan, Inc.**

**Shonan EMC Lab.**

1-22-3 Megumigaoka, Hiratsuka-shi, Kanagawa-ken, 259-1220 JAPAN

Telephone : +81 463 50 6400

Facsimile : +81 463 50 6401

## Radiated Spurious Emission

Report No. 13004393S-A-R2  
Test place Shonan EMC Lab.  
Semi Anechoic Chamber No.3 No.3  
Date September 10, 2019 September 13, 2019  
Temperature / Humidity 23 deg.C / 55 %RH 23 deg.C / 52 %RH  
Engineer Kazuya Noda Kazuya Noda  
(1 GHz – 13 GHz) (13 GHz – 26.5 GHz)  
Mode Tx 11n-20 MIMO, high power, 2437 MHz  
EUT Serial No. B-2  
Antenna Chain-0: Dual Monopole Antenna  
Chain-1: Monopole Antenna

(\* PK: Peak, AV: Average, QP: Quasi-Peak)

Polarity	Frequency [MHz]	Detector	Reading [dBuV]	Ant.Fac. [dB/m]	Loss [dB]	Gain [dB]	Distance Factor [dB]	Result [dBuV/m]	Limit [dBuV/m]	Margin [dB]	Height [cm]	Angle [deg]	Remark
Hori.	4874.000	PK	49.44	31.70	6.49	42.89	2.15	46.89	73.9	27.0	135	343	-
Hori.	7311.000	PK	48.51	37.36	7.95	43.13	2.15	52.84	73.9	21.0	100	0	-
Hori.	9748.000	PK	49.11	39.31	9.21	43.02	2.15	56.76	73.9	17.1	140	64	-
Hori.	4874.000	AV	38.22	31.70	6.49	42.89	2.15	35.67	53.9	18.2	135	343	VBW: 1 kHz
Hori.	7311.000	AV	37.12	37.36	7.95	43.13	2.15	41.45	53.9	12.4	100	0	VBW: 1 kHz
Hori.	9748.000	AV	38.14	39.31	9.21	43.02	2.15	45.79	53.9	<b>8.1</b>	140	64	VBW: 1 kHz
Vert.	4874.000	PK	50.53	31.70	6.49	42.89	2.15	47.98	73.9	25.9	284	181	-
Vert.	7311.000	PK	48.12	37.36	7.95	43.13	2.15	52.45	73.9	21.4	100	0	-
Vert.	9748.000	PK	49.05	39.31	9.21	43.02	2.15	56.70	73.9	17.2	231	126	-
Vert.	4874.000	AV	40.05	31.70	6.49	42.89	2.15	37.50	53.9	16.4	284	181	VBW: 1 kHz
Vert.	7311.000	AV	37.33	37.36	7.95	43.13	2.15	41.66	53.9	12.2	100	0	VBW: 1 kHz
Vert.	9748.000	AV	37.69	39.31	9.21	43.02	2.15	45.34	53.9	8.5	231	126	VBW: 1 kHz

Result = Reading + Ant.Fac. + Loss (Cable+(Attenuator or Filter)(below 18 GHz)) - Gain(Amplifier) + Distance factor

Distance factor : 1 GHz - 13 GHz :  $20 \log (3.84 \text{ m} / 3.0 \text{ m}) = 2.15 \text{ dB}$

13 GHz - 40 GHz :  $20 \log (1.0 \text{ m} / 3.0 \text{ m}) = -9.54 \text{ dB}$

**UL Japan, Inc.**

**Shonan EMC Lab.**

1-22-3 Megumigaoka, Hiratsuka-shi, Kanagawa-ken, 259-1220 JAPAN

Telephone : +81 463 50 6400

Facsimile : +81 463 50 6401

## Radiated Spurious Emission

Report No.	13004393S-A-R2		
Test place	Shonan EMC Lab.		
Semi Anechoic Chamber	No.3	No.3	No.3
Date	September 8, 2019	September 10, 2019	September 13, 2019
Temperature / Humidity	23 deg.C / 62 %RH	23 deg.C / 55 %RH	23 deg.C / 52 %RH
Engineer	Kenichi Adachi	Kazuya Noda	Kazuya Noda
	(1 GHz – 2.8 GHz)	(2.8 GHz – 13 GHz)	(13 GHz – 26.5 GHz)
Mode	Tx 11n-20 MIMO, high power, 2462 MHz		
EUT Serial No.	B-2		
Antenna	Chain-0: Dual Monopole Antenna		
	Chain-1: Monopole Antenna		

(\* PK: Peak, AV: Average, QP: Quasi-Peak)

Polarity	Frequency [MHz]	Detector	Reading [dBuV]	Ant.Fac. [dB/m]	Loss [dB]	Gain [dB]	Distance Factor [dB]	Result [dBuV/m]	Limit [dBuV/m]	Margin [dB]	Height [cm]	Angle [deg]	Remark
Hori.	2483.500	PK	61.10	28.24	14.23	41.62	2.15	64.10	73.9	9.8	139	78	-
Hori.	4924.000	PK	49.81	31.82	6.52	42.90	2.15	47.40	73.9	26.5	159	352	-
Hori.	7386.000	PK	48.27	37.49	8.00	43.28	2.15	52.63	73.9	21.2	100	0	-
Hori.	9848.000	PK	48.71	39.33	9.24	42.92	2.15	56.51	73.9	17.3	137	65	-
Hori.	2483.500	AV	46.79	28.24	14.23	41.62	2.15	49.79	53.9	4.1	139	78	VBW: 1 kHz
Hori.	4924.000	AV	38.22	31.82	6.52	42.90	2.15	35.81	53.9	18.0	159	352	VBW: 1 kHz
Hori.	7386.000	AV	37.38	37.49	8.00	43.28	2.15	41.74	53.9	12.1	100	0	VBW: 1 kHz
Hori.	9848.000	AV	37.80	39.33	9.24	42.92	2.15	45.60	53.9	8.3	137	65	VBW: 1 kHz
Vert.	2483.500	PK	58.98	28.24	14.23	41.62	2.15	61.98	73.9	11.9	152	122	-
Vert.	4924.000	PK	49.94	31.82	6.52	42.90	2.15	47.53	73.9	26.3	274	185	-
Vert.	7386.000	PK	48.48	37.49	8.00	43.28	2.15	52.84	73.9	21.0	100	0	-
Vert.	9848.000	PK	48.29	39.33	9.24	42.92	2.15	56.09	73.9	17.8	291	126	-
Vert.	2483.500	AV	45.58	28.24	14.23	41.62	2.15	48.58	53.9	5.3	152	122	VBW: 1 kHz
Vert.	4924.000	AV	38.71	31.82	6.52	42.90	2.15	36.30	53.9	17.6	274	185	VBW: 1 kHz
Vert.	7386.000	AV	37.41	37.49	8.00	43.28	2.15	41.77	53.9	12.1	100	0	VBW: 1 kHz
Vert.	9848.000	AV	38.06	39.33	9.24	42.92	2.15	45.86	53.9	8.0	291	126	VBW: 1 kHz

Result = Reading + Ant.Fac. + Loss (Cable+(Attenuator or Filter)(below 18 GHz)) - Gain(Amplifier) + Distance factor

Distance factor : 1 GHz - 13 GHz :  $20 \log (3.84 \text{ m} / 3.0 \text{ m}) = 2.15 \text{ dB}$

13 GHz - 40 GHz :  $20 \log (1.0 \text{ m} / 3.0 \text{ m}) = -9.54 \text{ dB}$

**Radiated Spurious Emission**  
**(Reference Plot for band-edge)**

Report No. 13004393S-A-R2  
Test place Shonan EMC Lab.  
Semi Anechoic Chamber No.3  
Date September 8, 2019  
Temperature / Humidity 23 deg.C / 62 %RH  
Engineer Kenichi Adachi  
(1 GHz – 2.8 GHz)  
Mode Tx 11n-20 MIMO, high power, 2462 MHz  
EUT Serial No. B-2  
Antenna Chain-0: Dual Monopole Antenna  
Chain-1: Monopole Antenna

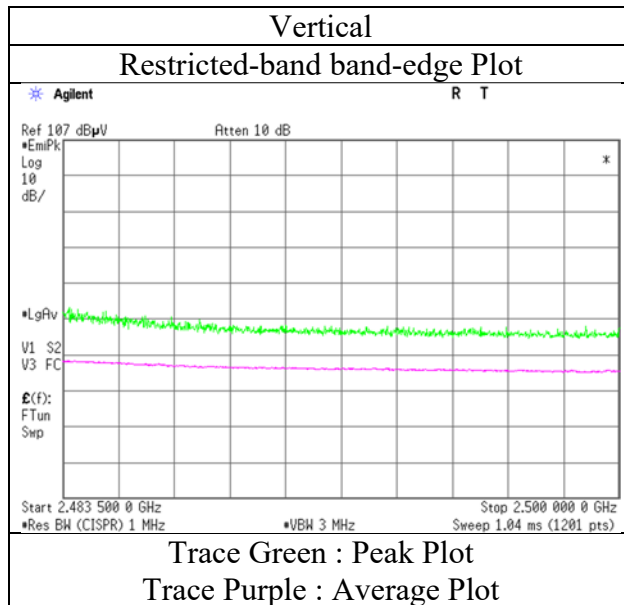
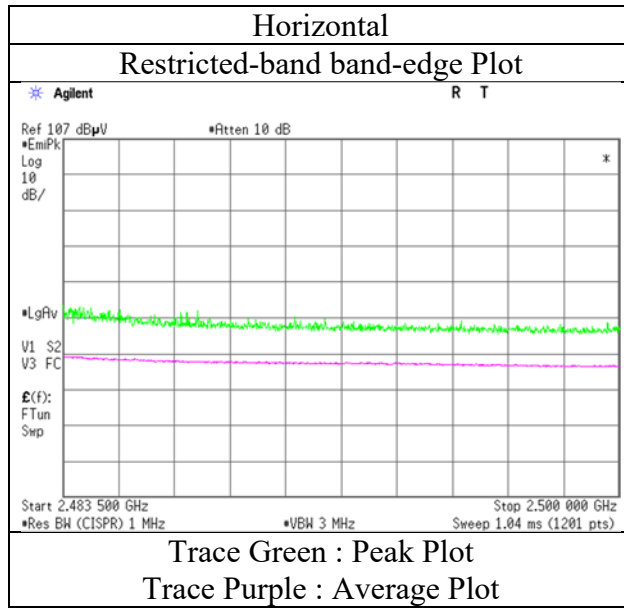

\* The measurement was conducted for a sufficiently long enough time to detect any possible spurious emissions. Final result of restricted band edge was shown in tabular data.



## Radiated Spurious Emission

Report No.	13004393S-A-R2		
Test place	Shonan EMC Lab.		
Semi Anechoic Chamber	No.3	No.3	No.3
Date	September 18, 2019	September 18, 2019	September 19, 2019
Temperature / Humidity	24 deg. C / 58 % RH	23 deg. C / 56 % RH	24 deg. C / 58 % RH
Engineer	Hiromasa Sato	Takahiro Suzuki	Kenichi Adachi
	(30 MHz – 1 GHz)	(1 GHz – 13 GHz)	(13 GHz – 26.5 GHz)
Mode	Tx BT LE 2402 MHz		
EUT Serial No.	A-9		
Antenna	Chain-0: Dual Monopole Antenna		

(\* PK: Peak, AV: Average, QP: Quasi-Peak)

Polarity	Frequency [MHz]	Detector	Reading [dBuV]	Ant.Fac. [dB/m]	Loss [dB]	Gain [dB]	Distance Factor [dB]	Result [dBuV/m]	Limit [dBuV/m]	Margin [dB]	Height [cm]	Angle [deg]	Remark
Hori.	133.437	QP	36.30	13.95	7.50	32.13	0.00	25.62	43.5	17.8	236	207	-
Hori.	714.003	QP	35.00	19.62	10.42	31.84	0.00	33.20	46.0	12.8	165	305	-
Hori.	918.001	QP	28.20	21.64	11.07	30.93	0.00	29.98	46.0	16.0	100	290	-
Hori.	2390.000	PK	51.88	28.33	14.16	41.59	2.15	54.93	73.9	18.9	211	65	-
Hori.	4804.000	PK	50.61	31.62	6.44	42.88	2.15	47.94	73.9	25.9	132	62	-
Hori.	7206.000	PK	48.31	37.23	7.87	42.92	2.15	52.64	73.9	21.2	150	0	-
Hori.	9608.000	PK	48.57	38.84	9.17	43.17	2.15	55.56	73.9	18.3	136	59	-
Vert.	67.432	QP	42.30	6.72	6.65	32.18	0.00	23.49	40.0	16.5	100	174	-
Vert.	107.704	QP	39.20	11.41	7.30	32.15	0.00	25.76	43.5	17.7	100	142	-
Vert.	164.304	QP	35.20	15.25	7.92	32.11	0.00	26.26	43.5	17.2	100	308	-
Vert.	177.029	QP	34.80	15.80	7.88	32.09	0.00	26.39	43.5	17.1	100	325	-
Vert.	678.005	QP	33.70	19.29	10.29	31.90	0.00	31.38	46.0	14.6	100	172	-
Vert.	2390.000	PK	51.25	28.33	14.16	41.59	2.15	54.30	73.9	19.6	119	99	-
Vert.	4804.000	PK	49.81	31.62	6.44	42.88	2.15	47.14	73.9	26.7	119	289	-
Vert.	7206.000	PK	48.03	37.23	7.87	42.92	2.15	52.36	73.9	21.5	150	0	-
Vert.	9608.000	PK	49.03	38.84	9.17	43.17	2.15	56.02	73.9	17.8	114	87	-

Result = Reading + Ant.Fac. + Loss (Cable+(Attenuator or Filter)(below 18 GHz)) - Gain(Amplifier) + Distance factor

Distance factor : 1 GHz - 13 GHz :  $20 \log (3.84 \text{ m} / 3.0 \text{ m}) = 2.14 \text{ dB}$

13 GHz - 40 GHz :  $20 \log (1.0 \text{ m} / 3.0 \text{ m}) = -9.54 \text{ dB}$

### Average measurement value with duty factor

Polarity	Frequency [MHz]	Detector	Reading [dBuV]	Ant.Fac. [dB/m]	Loss [dB]	Gain [dB]	Duty Factor [dB]	Distance Factor [dB]	Result [dBuV/m]	Limit [dBuV/m]	Margin [dB]	Remark
Hori.	2390.000	AV	35.92	28.33	14.16	41.59	3.41	2.15	42.38	53.9	11.5	*1)
Hori.	4804.000	AV	38.89	31.62	6.44	42.88	3.41	2.15	39.63	53.9	14.2	-
Hori.	7206.000	AV	35.27	37.23	7.87	42.92	3.41	2.15	43.01	53.9	10.8	-
Hori.	9608.000	AV	36.34	38.84	9.17	43.17	3.41	2.15	46.74	53.9	7.1	-
Vert.	2390.000	AV	34.67	28.33	14.16	41.59	3.41	2.15	41.13	53.9	12.7	*1)
Vert.	4804.000	AV	39.38	31.62	6.44	42.88	3.41	2.15	40.12	53.9	13.7	-
Vert.	7206.000	AV	36.39	37.23	7.87	42.92	3.41	2.15	44.13	53.9	9.7	-
Vert.	9608.000	AV	36.48	38.84	9.17	43.17	3.41	2.15	46.88	53.9	7.0	-

Result = Reading + Ant.Fac. + Loss (Cable+(Attenuator or Filter)(below 18 GHz)) - Gain(Amplifier) + Duty factor + Distance factor

Distance factor : 1 GHz - 13 GHz :  $20 \log (3.84 \text{ m} / 3.0 \text{ m}) = 2.14 \text{ dB}$

13 GHz - 40 GHz :  $20 \log (1.0 \text{ m} / 3.0 \text{ m}) = -9.54 \text{ dB}$

Duty factor refer to "Duty factor Calculation chart" sheet.

\*1) Not out of band emission (Leakage Power)

### 20 dBc Data Sheet (RBW 100 kHz, VBW 300 kHz)

Polarity	Frequency [MHz]	Detector	Reading [dBuV]	Ant.Fac. [dB/m]	Loss [dB]	Gain [dB]	Distance Factor [dB]	Result [dBuV/m]	Limit [dBuV/m]	Margin [dB]	Remark
Hori.	2402.000	PK	104.05	28.31	14.17	41.60	2.15	107.08	-	-	carrier
Hori.	2400.000	PK	46.21	28.31	14.16	41.60	2.15	49.23	87.08	37.8	-
Vert.	2402.000	PK	103.93	28.31	14.17	41.60	2.15	106.96	-	-	carrier
Vert.	2400.000	PK	45.32	28.31	14.16	41.60	2.15	48.34	86.96	38.6	-

Result = Reading + Ant.Fac. + Loss (Cable+(Attenuator or Filter)(below 18 GHz)) - Gain(Amplifier) + Distance factor

Distance factor : 1 GHz - 13 GHz :  $20 \log (3.84 \text{ m} / 3.0 \text{ m}) = 2.14 \text{ dB}$

13 GHz - 40 GHz :  $20 \log (1.0 \text{ m} / 3.0 \text{ m}) = -9.54 \text{ dB}$

**UL Japan, Inc.**

**Shonan EMC Lab.**

1-22-3 Megumigaoka, Hiratsuka-shi, Kanagawa-ken, 259-1220 JAPAN

Telephone : +81 463 50 6400

Facsimile : +81 463 50 6401

**Radiated Spurious Emission**  
**(Reference Plot for band-edge)**

Report No.	13004393S-A-R2
Test place	Shonan EMC Lab.
Semi Anechoic Chamber	No.3
Date	September 18, 2019
Temperature / Humidity	23 deg. C / 56 % RH
Engineer	Takahi Suzuki
	(1 GHz – 13 GHz)
Mode	Tx BT LE 2402 MHz
EUT Serial No.	A-9
Antenna	Chain-0: Dual Monopole Antenna

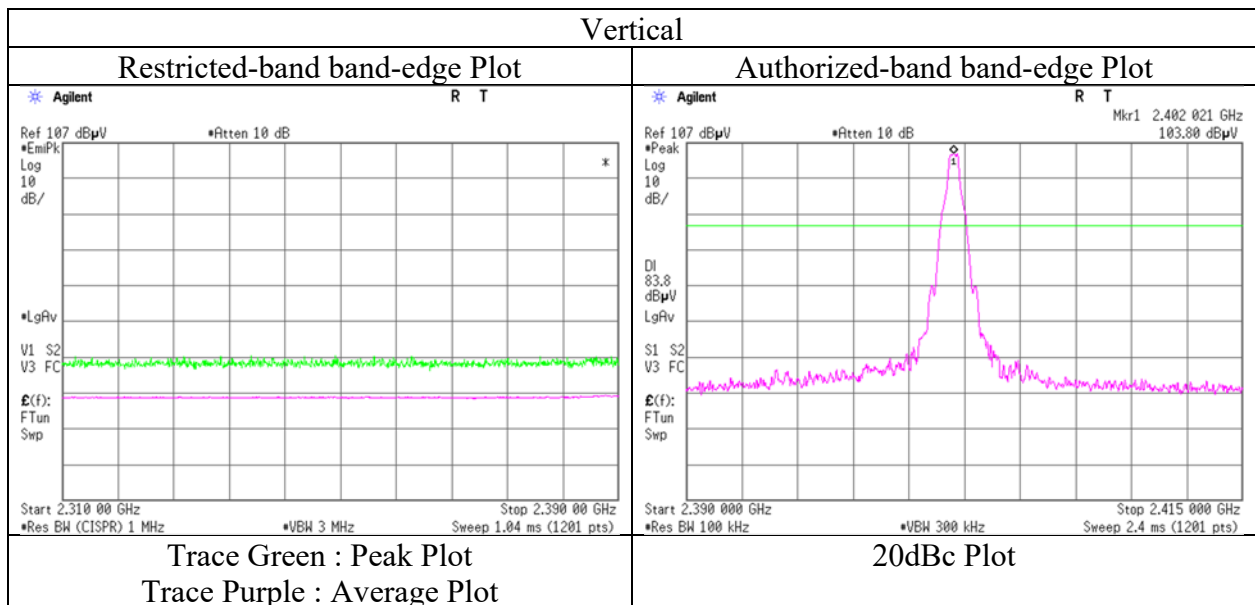
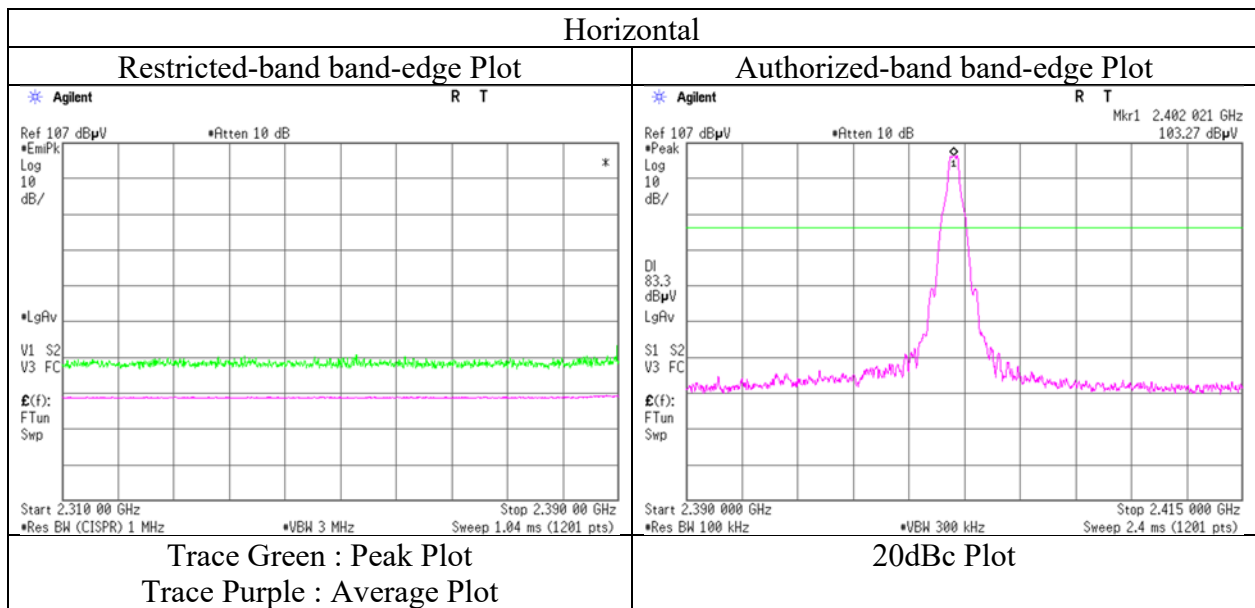

\* The measurement was conducted for a sufficiently long enough time to detect any possible spurious emissions. Final result of restricted band edge was shown in tabular data.

## Radiated Spurious Emission

Report No.	13004393S-A-R2		
Test place	Shonan EMC Lab.		
Semi Anechoic Chamber	No.3	No.3	No.3
Date	September 18, 2019	September 18, 2019	September 19, 2019
Temperature / Humidity	24 deg. C / 58 % RH	23 deg. C / 56 % RH	24 deg. C / 58 % RH
Engineer	Hiromasa Sato (30 MHz – 1 GHz)	Takahiro Suzuki (1 GHz – 13 GHz)	Kenichi Adachi (13 GHz – 26.5 GHz)
Mode	Tx BT LE 2440 MHz		
EUT Serial No.	A-9		
Antenna	Chain-0: Dual Monopole Antenna		

(\* PK: Peak, AV: Average, QP: Quasi-Peak)

Polarity	Frequency [MHz]	Detector	Reading [dBuV]	Ant.Fac. [dB/m]	Loss [dB]	Gain [dB]	Distance Factor [dB]	Result [dBuV/m]	Limit [dBuV/m]	Margin [dB]	Height [cm]	Angle [deg]	Remark
Hori.	133.226	QP	36.40	13.93	7.50	32.13	0.00	25.70	43.5	17.8	236	202	-
Hori.	714.002	QP	34.50	19.62	10.42	31.84	0.00	32.70	46.0	13.3	162	308	-
Hori.	949.838	QP	27.90	21.59	11.17	30.64	0.00	30.02	46.0	15.9	100	290	-
Hori.	4880.000	PK	49.99	31.71	6.49	42.89	2.15	47.45	73.9	26.4	133	67	-
Hori.	7320.000	PK	47.63	37.38	7.95	43.15	2.15	51.96	73.9	21.9	150	0	-
Hori.	9760.000	PK	47.07	39.33	9.21	43.01	2.15	54.75	73.9	19.1	150	0	-
Vert.	67.453	QP	42.60	6.72	6.65	32.18	0.00	23.79	40.0	16.2	100	171	-
Vert.	107.556	QP	38.90	11.39	7.30	32.15	0.00	25.44	43.5	18.0	100	139	-
Vert.	163.507	QP	35.50	15.19	7.92	32.11	0.00	26.50	43.5	17.0	100	305	-
Vert.	176.594	QP	34.60	15.79	7.88	32.09	0.00	26.18	43.5	17.3	100	314	-
Vert.	720.002	QP	33.00	19.75	10.44	31.83	0.00	31.36	46.0	14.6	100	185	-
Vert.	4880.000	PK	48.78	31.71	6.49	42.89	2.15	46.24	73.9	27.6	135	208	-
Vert.	7320.000	PK	48.05	37.38	7.95	43.15	2.15	52.38	73.9	21.5	150	0	-
Vert.	9760.000	PK	47.11	39.33	9.21	43.01	2.15	54.79	73.9	19.1	150	0	-

Result = Reading + Ant.Fac. + Loss (Cable+(Attenuator or Filter)(below 18 GHz)) - Gain(Amplifier) + Distance factor

Distance factor : 1 GHz - 13 GHz :  $20 \log(3.84 \text{ m} / 3.0 \text{ m}) = 2.14 \text{ dB}$

13 GHz - 40 GHz :  $20 \log(1.0 \text{ m} / 3.0 \text{ m}) = -9.54 \text{ dB}$

### Average measurement value with duty factor

Polarity	Frequency [MHz]	Detector	Reading [dBuV]	Ant.Fac. [dB/m]	Loss [dB]	Gain [dB]	Duty Factor [dB]	Distance Factor [dB]	Result [dBuV/m]	Limit [dBuV/m]	Margin [dB]	Remark
Hori.	4880.000	AV	39.98	31.71	6.49	42.89	3.41	2.15	40.85	53.9	13.0	-
Hori.	7320.000	AV	36.26	37.38	7.95	43.15	3.41	2.15	44.00	53.9	9.9	-
Hori.	9760.000	AV	36.38	39.33	9.21	43.01	3.41	2.15	47.47	53.9	6.4	-
Vert.	4880.000	AV	38.32	31.71	6.49	42.89	3.41	2.15	39.19	53.9	14.7	-
Vert.	7320.000	AV	37.13	37.38	7.95	43.15	3.41	2.15	44.87	53.9	9.0	-
Vert.	9760.000	AV	36.19	39.33	9.21	43.01	3.41	2.15	47.28	53.9	6.6	-

Result = Reading + Ant.Fac. + Loss (Cable+(Attenuator or Filter)(below 18 GHz)) - Gain(Amplifier) + Duty factor + Distance factor

Distance factor : 1 GHz - 13 GHz :  $20 \log(3.84 \text{ m} / 3.0 \text{ m}) = 2.14 \text{ dB}$

13 GHz - 40 GHz :  $20 \log(1.0 \text{ m} / 3.0 \text{ m}) = -9.54 \text{ dB}$

Duty factor refer to "Duty factor Calculation chart" sheet.

\*1) Not out of band emission (Leakage Power)

**UL Japan, Inc.**

**Shonan EMC Lab.**

1-22-3 Megumigaoka, Hiratsuka-shi, Kanagawa-ken, 259-1220 JAPAN

Telephone : +81 463 50 6400

Facsimile : +81 463 50 6401

## Radiated Spurious Emission

Report No.	13004393S-A-R2		
Test place	Shonan EMC Lab.		
Semi Anechoic Chamber	No.3	No.3	No.3
Date	September 18, 2019	September 18, 2019	September 19, 2019
Temperature / Humidity	24 deg. C / 58 % RH	23 deg. C / 56 % RH	24 deg. C / 58 % RH
Engineer	Hiromasa Sato	Takahiro Suzuki	Kenichi Adachi
	(30 MHz – 1 GHz)	(1 GHz – 13 GHz)	(13 GHz – 26.5 GHz)
Mode	Tx BT LE 2480 MHz		
EUT Serial No.	A-9		
Antenna	Chain-0: Dual Monopole Antenna		

(\* PK: Peak, AV: Average, QP: Quasi-Peak)

Polarity	Frequency [MHz]	Detector	Reading [dBuV]	Ant.Fac. [dB/m]	Loss [dB]	Gain [dB]	Distance Factor [dB]	Result [dBuV/m]	Limit [dBuV/m]	Margin [dB]	Height [cm]	Angle [deg]	Remark
Hori.	133.397	QP	36.20	13.94	7.50	32.13	0.00	25.51	43.5	17.9	230	200	-
Hori.	708.001	QP	34.10	19.51	10.40	31.85	0.00	32.16	46.0	13.8	159	307	-
Hori.	949.857	QP	27.40	21.59	11.17	30.64	0.00	29.52	46.0	16.4	100	291	-
Hori.	2483.500	PK	58.78	28.24	14.24	41.62	2.15	61.79	73.9	12.1	143	61	-
Hori.	4960.000	PK	48.88	31.96	6.54	42.91	2.15	46.62	73.9	27.2	157	70	-
Hori.	7440.000	PK	47.63	37.56	8.03	43.38	2.15	51.99	73.9	21.9	150	0	-
Hori.	9920.000	PK	46.99	39.18	9.26	42.84	2.15	54.74	73.9	19.1	150	0	-
Vert.	67.531	QP	42.60	6.71	6.65	32.18	0.00	23.78	40.0	16.2	100	175	-
Vert.	107.429	QP	38.90	11.36	7.30	32.15	0.00	25.41	43.5	18.0	100	135	-
Vert.	163.864	QP	35.20	15.21	7.91	32.11	0.00	26.21	43.5	17.2	100	306	-
Vert.	176.696	QP	34.50	15.79	7.88	32.09	0.00	26.08	43.5	17.4	100	319	-
Vert.	714.002	QP	33.40	19.62	10.42	31.84	0.00	31.60	46.0	14.4	100	183	-
Vert.	2483.500	PK	58.27	28.24	14.24	41.62	2.15	61.28	73.9	12.6	115	100	-
Vert.	4960.000	PK	48.99	31.96	6.54	42.91	2.15	46.73	73.9	27.1	165	208	-
Vert.	7440.000	PK	48.47	37.56	8.03	43.38	2.15	52.83	73.9	21.0	150	0	-
Vert.	9920.000	PK	46.09	39.18	9.26	42.84	2.15	53.84	73.9	20.0	150	0	-

Result = Reading + Ant.Fac. + Loss (Cable+(Attenuator or Filter)(below 18 GHz)) - Gain(Amplifier) + Distance factor

Distance factor : 1 GHz - 13 GHz :  $20 \log ( 3.84 \text{ m} / 3.0 \text{ m} ) = 2.14 \text{ dB}$

13 GHz - 40 GHz :  $20 \log ( 1.0 \text{ m} / 3.0 \text{ m} ) = -9.54 \text{ dB}$

### Average measurement value with duty factor

Polarity	Frequency [MHz]	Detector	Reading [dBuV]	Ant.Fac. [dB/m]	Loss [dB]	Gain [dB]	Duty Factor [dB]	Distance Factor [dB]	Result [dBuV/m]	Limit [dBuV/m]	Margin [dB]	Remark
Hori.	2483.500	AV	37.77	28.24	14.24	41.62	3.41	2.15	44.19	53.9	9.7	*1)
Hori.	4960.000	AV	37.69	31.96	6.54	42.91	3.41	2.15	38.84	53.9	15.0	-
Hori.	7440.000	AV	36.15	37.56	8.03	43.38	3.41	2.15	43.92	53.9	9.9	-
Hori.	9920.000	AV	35.27	39.18	9.26	42.84	3.41	2.15	46.43	53.9	7.4	-
Vert.	2483.500	AV	38.42	28.24	14.24	41.62	3.41	2.15	44.84	53.9	9.0	*1)
Vert.	4960.000	AV	37.68	31.96	6.54	42.91	3.41	2.15	38.83	53.9	15.0	-
Vert.	7440.000	AV	36.34	37.56	8.03	43.38	3.41	2.15	44.11	53.9	9.7	-
Vert.	9920.000	AV	34.93	39.18	9.26	42.84	3.41	2.15	46.09	53.9	7.8	-

Result = Reading + Ant.Fac. + Loss (Cable+(Attenuator or Filter)(below 18 GHz)) - Gain(Amplifier) + Duty factor + Distance factor

Distance factor : 1 GHz - 13 GHz :  $20 \log ( 3.84 \text{ m} / 3.0 \text{ m} ) = 2.14 \text{ dB}$

13 GHz - 40 GHz :  $20 \log ( 1.0 \text{ m} / 3.0 \text{ m} ) = -9.54 \text{ dB}$

Duty factor refer to "Duty factor Calculation chart" sheet.

\*1) Not out of band emission (Leakage Power)

**UL Japan, Inc.**

**Shonan EMC Lab.**

1-22-3 Megumigaoka, Hiratsuka-shi, Kanagawa-ken, 259-1220 JAPAN

Telephone : +81 463 50 6400

Facsimile : +81 463 50 6401

**Radiated Spurious Emission**  
**(Reference Plot for band-edge)**

Report No.	13004393S-A-R2
Test place	Shonan EMC Lab.
Semi Anechoic Chamber	No.3
Date	September 18, 2019
Temperature / Humidity	23 deg. C / 56 % RH
Engineer	Takahiro Suzuki (1 GHz – 13 GHz)
Mode	Tx BT LE 2480 MHz
EUT Serial No.	A-9
Antenna	Chain-0: Dual Monopole Antenna

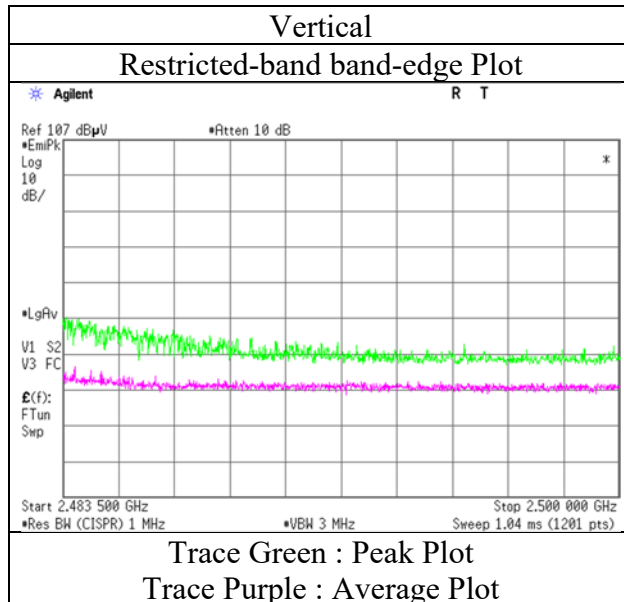
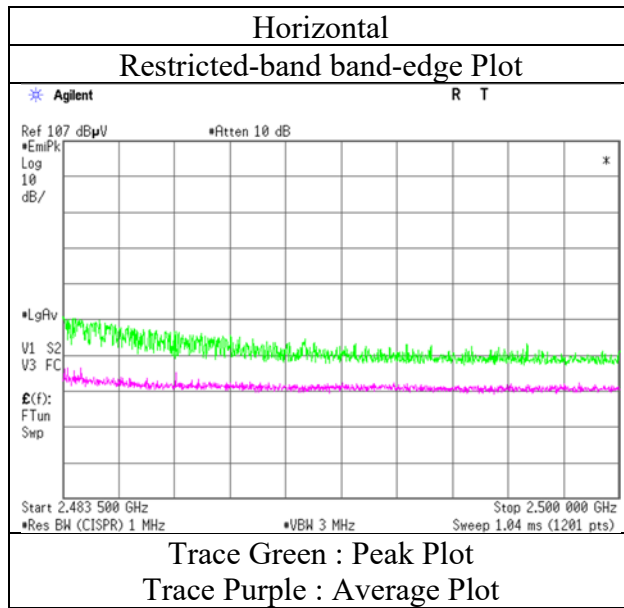

\* The measurement was conducted for a sufficiently long enough time to detect any possible spurious emissions. Final result of restricted band edge was shown in tabular data.

## Radiated Spurious Emission

Report No. 13004393S-A-R2  
Test place Shonan EMC Lab.  
Semi Anechoic Chamber No.3  
Date September 20, 2019  
Temperature / Humidity 24 deg. C / 58 % RH  
Engineer Takahiro Suzuki  
(1 GHz – 2.8 GHz)  
Mode Tx BT LE 2402 MHz with Tx 11ac-40, high power, 5190 MHz  
EUT Serial No. A-9  
Antenna Chain-0: Dual Monopole Antenna  
Chain-1: Dual Monopole Antenna

(\* PK: Peak, AV: Average, QP: Quasi-Peak)

Polarity	Frequency [MHz]	Detector	Reading [dBuV]	Ant.Fac. [dB/m]	Loss [dB]	Gain [dB]	Distance Factor [dB]	Result [dBuV/m]	Limit [dBuV/m]	Margin [dB]	Height [cm]	Angle [deg]	Remark
Hori.	2390.000	PK	54.48	28.33	14.16	41.59	2.15	57.53	73.9	16.3	144	70	-
Vert.	2390.000	PK	54.76	28.33	14.16	41.59	2.15	57.81	73.9	<b>16.0</b>	100	102	-

Result = Reading + Ant.Fac. + Loss (Cable+(Attenuator or Filter)(below 18 GHz)) - Gain(Amplifier) + Distance factor

Distance factor : 1 GHz - 13 GHz :  $20 \log(3.84 \text{ m} / 3.0 \text{ m}) = 2.14 \text{ dB}$

13 GHz - 40 GHz :  $20 \log(1.0 \text{ m} / 3.0 \text{ m}) = -9.54 \text{ dB}$

### Average measurement value with duty factor

Polarity	Frequency [MHz]	Detector	Reading [dBuV]	Ant.Fac. [dB/m]	Loss [dB]	Gain [dB]	Duty Factor [dB]	Distance Factor [dB]	Result [dBuV/m]	Limit [dBuV/m]	Margin [dB]	Remark
Hori.	2390.000	AV	38.63	28.33	14.16	41.59	3.41	2.15	45.09	53.9	<b>8.8</b> *1)	
Vert.	2390.000	AV	37.43	28.33	14.16	41.59	3.41	2.15	43.89	53.9	10.0	*1)

Result = Reading + Ant.Fac. + Loss (Cable+(Attenuator or Filter)(below 18 GHz)) - Gain(Amplifier) + Duty factor + Distance factor

Distance factor : 1 GHz - 13 GHz :  $20 \log(3.84 \text{ m} / 3.0 \text{ m}) = 2.14 \text{ dB}$

13 GHz - 40 GHz :  $20 \log(1.0 \text{ m} / 3.0 \text{ m}) = -9.54 \text{ dB}$

Duty factor refer to "Duty factor Calculation chart" sheet.

\*1) Not out of band emission (Leakage Power)

### 20 dBc Data Sheet (RBW 100 kHz, VBW 300 kHz)

Polarity	Frequency [MHz]	Detector	Reading [dBuV]	Ant.Fac. [dB/m]	Loss [dB]	Gain [dB]	Distance Factor [dB]	Result [dBuV/m]	Limit [dBuV/m]	Margin [dB]	Remark
Hori.	2402.000	PK	103.50	28.31	14.17	41.60	2.15	106.53	-	-	Carrier
Hori.	2400.000	PK	46.02	28.31	14.16	41.60	2.15	49.04	86.53	37.4	-
Vert.	2402.000	PK	102.74	28.31	14.17	41.60	2.15	105.77	-	-	Carrier
Vert.	2400.000	PK	45.09	28.31	14.16	41.60	2.15	48.11	85.77	37.6	-

Result = Reading + Ant.Fac. + Loss (Cable+(Attenuator or Filter)(below 18 GHz)) - Gain(Amplifier) + Distance factor

Distance factor : 1 GHz - 13 GHz :  $20 \log(3.84 \text{ m} / 3.0 \text{ m}) = 2.14 \text{ dB}$

13 GHz - 40 GHz :  $20 \log(1.0 \text{ m} / 3.0 \text{ m}) = -9.54 \text{ dB}$

**Radiated Spurious Emission**  
**(Reference Plot for band-edge)**

Report No. 13004393S-A-R2  
Test place Shonan EMC Lab.  
Semi Anechoic Chamber No.3  
Date September 20, 2019  
Temperature / Humidity 24 deg. C / 58 % RH  
Engineer Takahiro Suzuki  
(1 GHz – 2.8 GHz)  
Mode Tx BT LE 2402 MHz with Tx 11ac-40, high power, 5190 MHz  
EUT Serial No. A-9  
Antenna Chain-0: Dual Monopole Antenna  
Chain-1: Dual Monopole Antenna

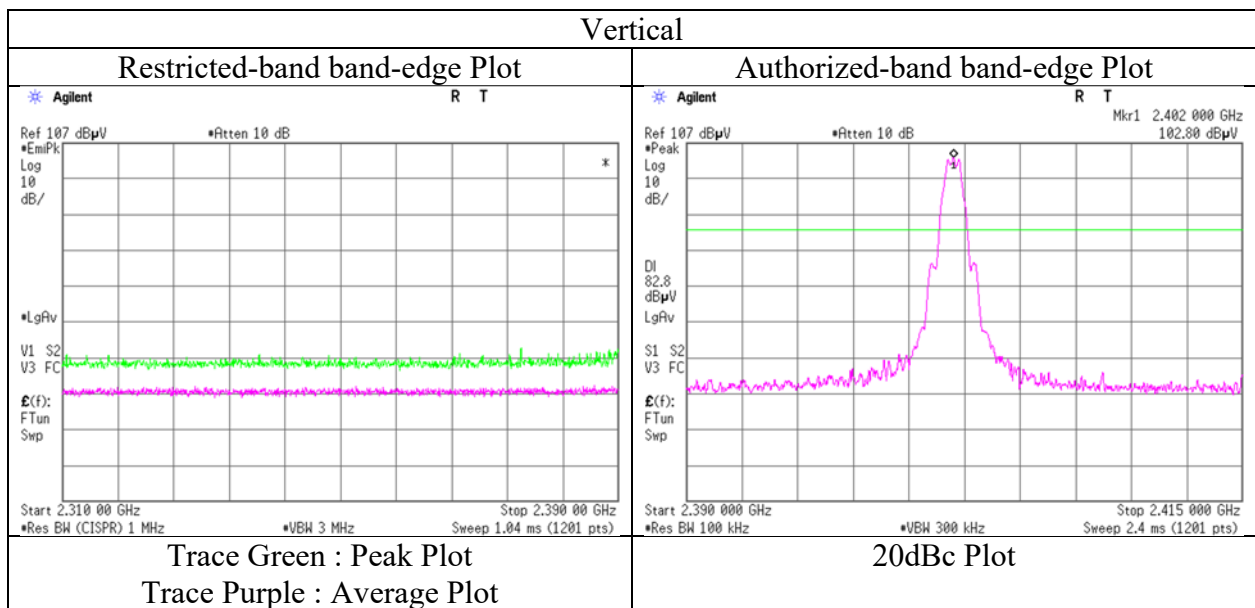
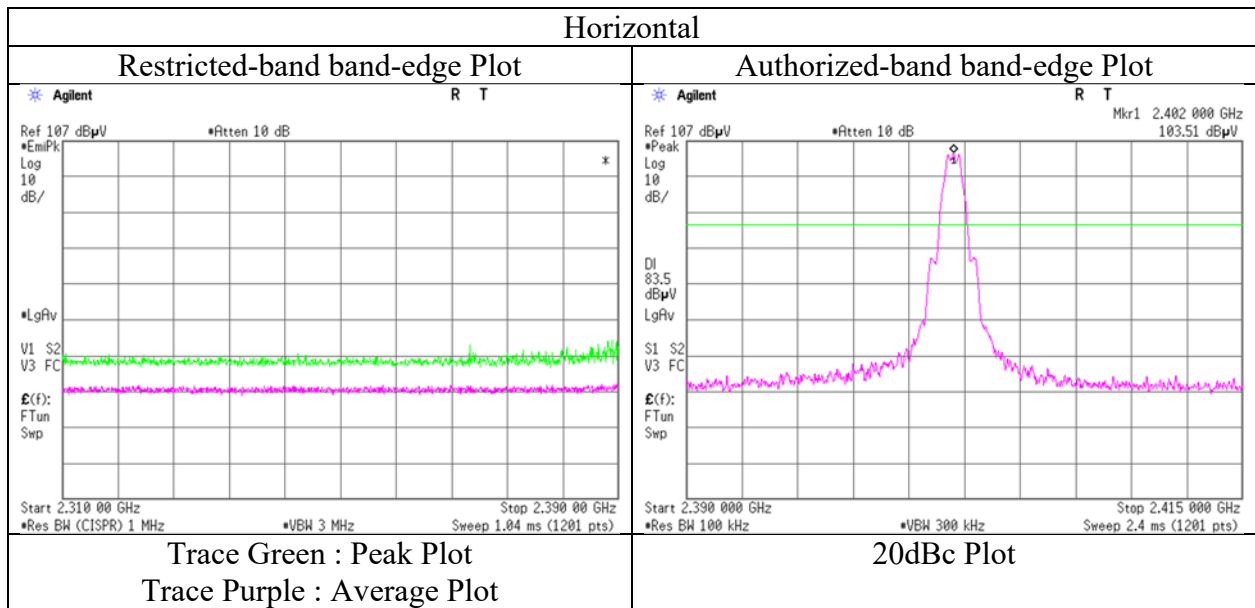

\* The measurement was conducted for a sufficiently long enough time to detect any possible spurious emissions.  
Final result of restricted band edge was shown in tabular data.

## Radiated Spurious Emission

Report No. 13004393S-A-R2  
Test place Shonan EMC Lab.  
Semi Anechoic Chamber No.3 No.3  
Date September 19, 2019 September 20, 2019  
Temperature / Humidity 24 deg. C / 58 % RH 24 deg. C / 58 % RH  
Engineer Takahiro Suzuki Takahiro Suzuki  
(30 MHz – 1 GHz) (1 GHz – 26.5 GHz)  
Mode Tx BT LE 2440 MHz with Tx 11ac-40, high power, 5190 MHz  
EUT Serial No. A-9  
Antenna Chain-0: Dual Monopole Antenna  
Chain-1: Dual Monopole Antenna

(\* PK: Peak, AV: Average, QP: Quasi-Peak)

Polarity	Frequency [MHz]	Detector	Reading [dBuV]	Ant.Fac. [dB/m]	Loss [dB]	Gain [dB]	Distance Factor [dB]	Result [dBuV/m]	Limit [dBuV/m]	Margin [dB]	Height [cm]	Angle [deg]	Remark
Hori.	153.178	QP	35.85	14.82	7.86	32.12	0.00	26.41	43.5	17.0	219	233	-
Hori.	226.276	QP	43.05	11.03	8.25	32.04	0.00	30.29	46.0	15.7	155	186	-
Hori.	239.899	QP	44.29	11.31	8.35	32.02	0.00	31.93	46.0	14.0	100	117	-
Hori.	701.997	QP	37.43	19.37	10.38	31.86	0.00	35.32	46.0	10.6	144	359	-
Hori.	713.952	QP	35.12	19.62	10.42	31.84	0.00	33.32	46.0	12.6	136	29	-
Hori.	945.670	QP	31.98	21.57	11.16	30.68	0.00	34.03	46.0	11.9	100	273	-
Hori.	4880.000	PK	51.04	31.71	6.49	42.89	2.15	48.50	73.9	25.4	130	62	-
Hori.	7320.000	PK	47.55	37.38	7.95	43.15	2.15	51.88	73.9	22.0	150	0	-
Hori.	9760.000	PK	47.28	39.33	9.21	43.01	2.15	54.96	73.9	18.9	150	0	-
Vert.	107.458	QP	44.34	11.37	7.30	32.15	0.00	30.86	43.5	12.6	100	132	-
Vert.	164.547	QP	40.51	15.27	7.92	32.11	0.00	31.59	43.5	11.9	100	353	-
Vert.	707.935	QP	36.37	19.51	10.40	31.85	0.00	34.43	46.0	11.5	100	352	-
Vert.	725.996	QP	36.32	19.86	10.46	31.82	0.00	34.82	46.0	11.1	100	355	-
Vert.	4880.000	PK	49.00	31.71	6.49	42.89	2.15	46.46	73.9	27.4	124	187	-
Vert.	7320.000	PK	47.75	37.38	7.95	43.15	2.15	52.08	73.9	21.8	150	0	-
Vert.	9760.000	PK	47.00	39.33	9.21	43.01	2.15	54.68	73.9	19.2	150	0	-

Result = Reading + Ant.Fac. + Loss (Cable+(Attenuator or Filter)(below 18 GHz)) - Gain(Amplifier) + Distance factor

Distance factor : 1 GHz - 13 GHz :  $20 \log(3.84 \text{ m} / 3.0 \text{ m}) = 2.14 \text{ dB}$

13 GHz - 40 GHz :  $20 \log(1.0 \text{ m} / 3.0 \text{ m}) = -9.54 \text{ dB}$

### Average measurement value with duty factor

Polarity	Frequency [MHz]	Detector	Reading [dBuV]	Ant.Fac. [dB/m]	Loss [dB]	Gain [dB]	Duty Factor [dB]	Distance Factor [dB]	Result [dBuV/m]	Limit [dBuV/m]	Margin [dB]	Remark
Hori.	4880.000	AV	40.04	31.71	6.49	42.89	3.41	2.15	40.91	53.9	12.9	--
Hori.	7320.000	AV	36.19	37.38	7.95	43.15	3.41	2.15	43.93	53.9	9.9	-
Hori.	9760.000	AV	36.28	39.33	9.21	43.01	3.41	2.15	47.37	53.9	6.5	-
Vert.	4880.000	AV	38.87	31.71	6.49	42.89	3.41	2.15	39.74	53.9	14.1	-
Vert.	7320.000	AV	36.98	37.38	7.95	43.15	3.41	2.15	44.72	53.9	9.1	-
Vert.	9760.000	AV	36.08	39.33	9.21	43.01	3.41	2.15	47.17	53.9	6.7	-

Result = Reading + Ant.Fac. + Loss (Cable+(Attenuator or Filter)(below 18 GHz)) - Gain(Amplifier) + Duty factor + Distance factor

Distance factor : 1 GHz - 13 GHz :  $20 \log(3.84 \text{ m} / 3.0 \text{ m}) = 2.14 \text{ dB}$

13 GHz - 40 GHz :  $20 \log(1.0 \text{ m} / 3.0 \text{ m}) = -9.54 \text{ dB}$

Duty factor refer to "Duty factor Calculation chart" sheet.

\*1) Not out of band emission (Leakage Power)



## Radiated Spurious Emission

Report No. 13004393S-A-R2  
Test place Shonan EMC Lab.  
Semi Anechoic Chamber No.3  
Date September 20, 2019  
Temperature / Humidity 24 deg. C / 58 % RH  
Engineer Takahiro Suzuki  
(1 GHz – 2.8 GHz)  
Mode Tx BT LE 2480 MHz with Tx 11ac-40, high power, 5190 MHz  
EUT Serial No. A-9  
Antenna Chain-0: Dual Monopole Antenna  
Chain-1: Dual Monopole Antenna

(\* PK: Peak, AV: Average, QP: Quasi-Peak)

Polarity	Frequency [MHz]	Detector	Reading [dBuV]	Ant.Fac. [dB/m]	Loss [dB]	Gain [dB]	Distance Factor [dB]	Result [dBuV/m]	Limit [dBuV/m]	Margin [dB]	Height [cm]	Angle [deg]	Remark
Hori.	2483.500	PK	53.76	28.24	14.24	41.62	2.15	56.77	73.9	17.1	131	71	-
Vert.	2483.500	PK	60.31	28.24	14.24	41.62	2.15	63.32	73.9	<b>10.5</b>	140	104	-

Result = Reading + Ant.Fac. + Loss (Cable+(Attenuator or Filter)(below 18 GHz)) - Gain(Amplifier) + Distance factor

Distance factor : 1 GHz - 13 GHz :  $20 \log(3.84 \text{ m} / 3.0 \text{ m}) = 2.14 \text{ dB}$

13 GHz - 40 GHz :  $20 \log(1.0 \text{ m} / 3.0 \text{ m}) = -9.54 \text{ dB}$

### Average measurement value with duty factor

Polarity	Frequency [MHz]	Detector	Reading [dBuV]	Ant.Fac. [dB/m]	Loss [dB]	Gain [dB]	Duty Factor [dB]	Distance Factor [dB]	Result [dBuV/m]	Limit [dBuV/m]	Margin [dB]	Remark
Hori.	2483.500	AV	38.45	28.24	14.24	41.62	3.41	2.15	44.87	53.9	9.0	*1)
Vert.	2483.500	AV	39.46	28.24	14.24	41.62	3.41	2.15	45.88	53.9	<b>8.0</b>	*1)

Result = Reading + Ant.Fac. + Loss (Cable+(Attenuator or Filter)(below 18 GHz)) - Gain(Amplifier) + Duty factor + Distance factor

Distance factor : 1 GHz - 13 GHz :  $20 \log(3.84 \text{ m} / 3.0 \text{ m}) = 2.14 \text{ dB}$

13 GHz - 40 GHz :  $20 \log(1.0 \text{ m} / 3.0 \text{ m}) = -9.54 \text{ dB}$

Duty factor refer to "Duty factor Calculation chart" sheet.

\*1) Not out of band emission (Leakage Power)

**Radiated Spurious Emission**  
**(Reference Plot for band-edge)**

Report No. 13004393S-A-R2  
Test place Shonan EMC Lab.  
Semi Anechoic Chamber No.3  
Date September 20, 2019  
Temperature / Humidity 24 deg. C / 58 % RH  
Engineer Takahiro Suzuki  
(1 GHz – 2.8 GHz)  
Mode Tx BT LE 2480 MHz with Tx 11ac-40, high power, 5190 MHz  
EUT Serial No. A-9  
Antenna Chain-0: Dual Monopole Antenna  
Chain-1: Dual Monopole Antenna

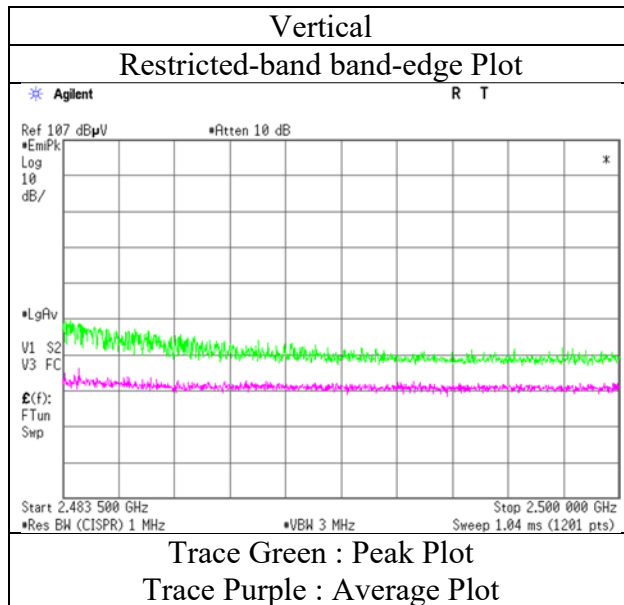
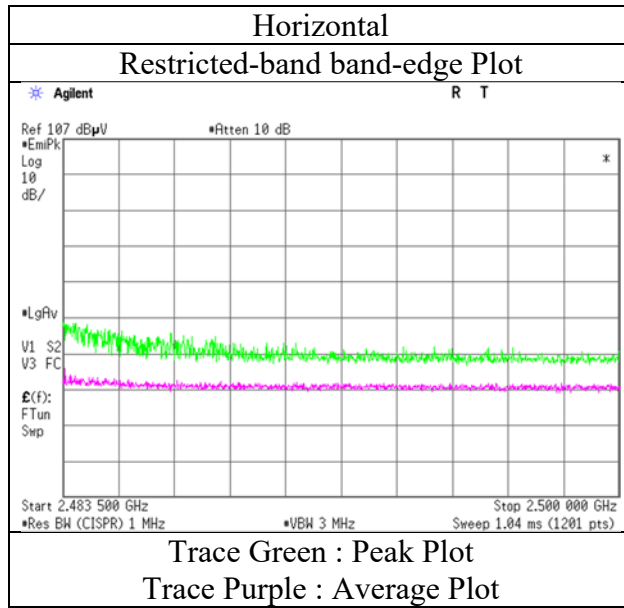

\* The measurement was conducted for a sufficiently long enough time to detect any possible spurious emissions. Final result of restricted band edge was shown in tabular data.

**Radiated Spurious Emission**  
**(Plot data, Worst case)**

Report No.	13004393S-A-R2			
Test place	Shonan EMC Lab.			
Semi Anechoic Chamber	No.3	No.3	No.3	No.3
Date	September 16, 2019	September 8, 2019	September 9, 2019	September 13, 2019
Temperature / Humidity	23 deg.C / 61 %RH	23 deg.C / 62 %RH	24 deg.C / 52 %RH	23 deg.C / 52 %RH
Engineer	Kenichi Adachi	Kenichi Adachi	Kazuya Noda	Kazuya Noda
	(30 MHz – 1 GHz)	(1 GHz – 2.8 GHz)	(2.8 GHz – 13 GHz)	(13 GHz – 26.5 GHz)
Mode	Tx 11g, high power, 2412 MHz			
EUT Serial No.	A-1			
Antenna	Chain-0: Dual Monopole Antenna Chain-1: Dual Monopole Antenna			

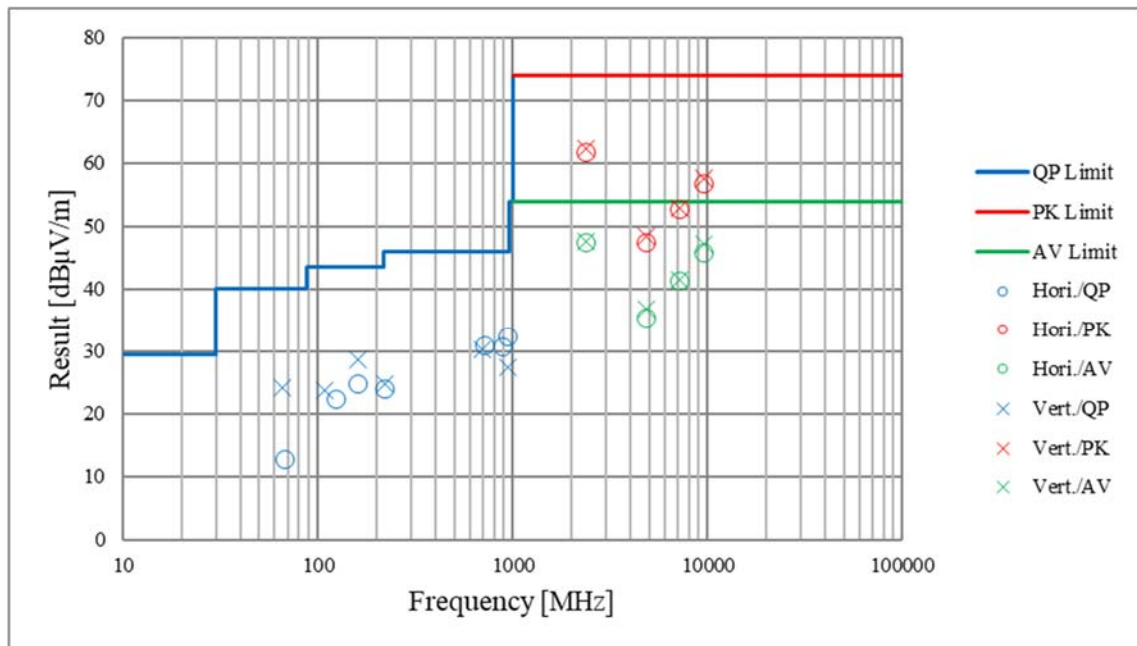

\*These plots data contains sufficient number to show the trend of characteristic features for EUT.

**Radiated Spurious Emission**  
**(Plot data, Worst case)**

Report No.	13004393S-A-R2		
Test place	Shonan EMC Lab.		
Semi Anechoic Chamber	No.3	No.3	No.3
Date	September 18, 2019	September 18, 2019	September 19, 2019
Temperature / Humidity	24 deg. C / 58 % RH	23 deg. C / 56 % RH	24 deg. C / 58 % RH
Engineer	Hiromasa Sato (30 MHz – 1 GHz)	Takahiro Suzuki (1 GHz – 13 GHz)	Kenichi Adachi (13 GHz – 26.5 GHz)
Mode	Tx BT LE 2440 MHz		
EUT Serial No.	A-9		
Antenna	Chain-0: Dual Monopole Antenna		

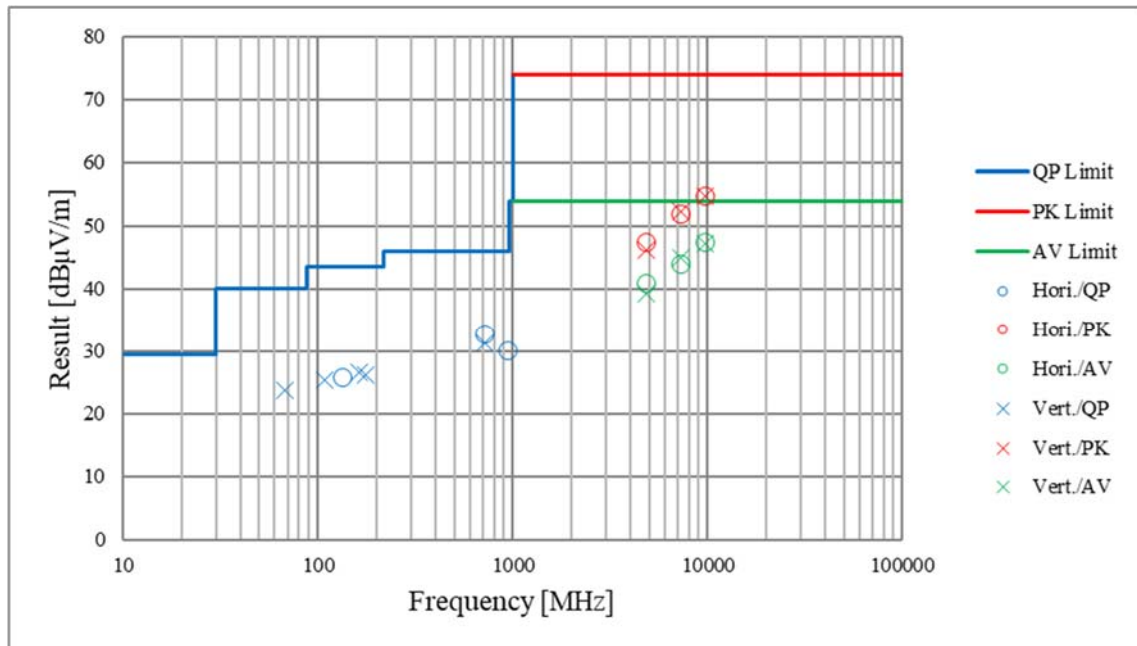

\*These plots data contains sufficient number to show the trend of characteristic features for EUT.

**Radiated Spurious Emission**  
**(Plot data, Worst case)**

Report No.	13004393S-A-R2	
Test place	Shonan EMC Lab.	
Semi Anechoic Chamber	No.3	No.3
Date	September 19, 2019	September 20, 2019
Temperature / Humidity	24 deg. C / 58 % RH	24 deg. C / 58 % RH
Engineer	Takahiro Suzuki	Takahiro Suzuki
	(30 MHz – 1 GHz)	(1 GHz – 26.5 GHz)
Mode	Tx BT LE 2440 MHz with Tx 11ac-40, high power, 5190 MHz	
EUT Serial No.	A-9	
Antenna	Chain-0: Dual Monopole Antenna	
	Chain-1: Dual Monopole Antenna	

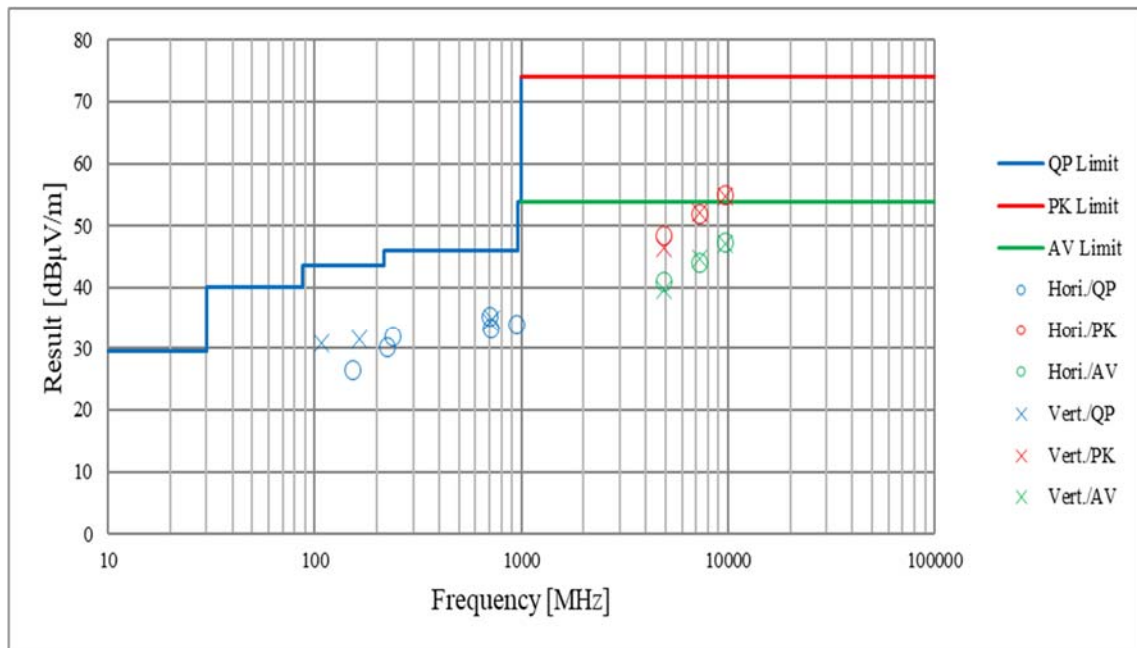

\*These plots data contains sufficient number to show the trend of characteristic features for EUT.

## Conducted Spurious Emission

Report No. 13004393S-A-R2  
Test place Shonan EMC Lab. No.3 Shielded Room  
Date September 23, 2019  
Temperature / Humidity 24 deg. C / 42 % RH  
Engineer Hiromasa Sato  
Mode Tx 11g, high power, 2412 MHz

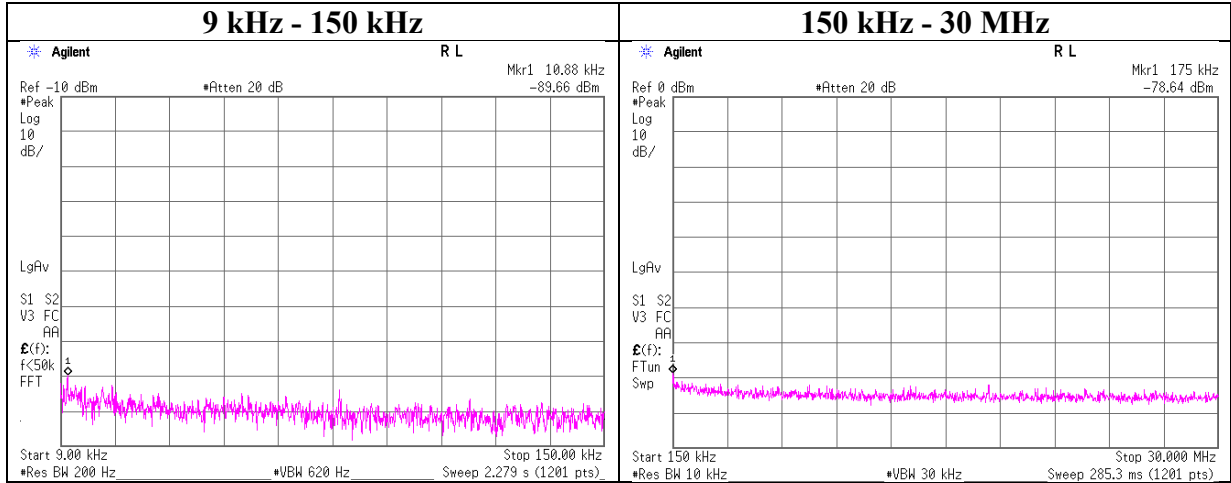

Frequency [kHz]	Reading [dBm]	Cable Loss [dB]	Attenuator Loss [dB]	Antenna Gain* [dBi]	N (Number of Output)	EIRP [dBm]	Distance [m]	Ground bounce [dB]	E (field strength) [dBuV/m]	Limit [dBuV/m]	Margin [dB]	Remark
10.88	-89.7	0.01	9.8	2.0	2	-74.8	300	6.0	-13.6	46.8	60.4	-
175.00	-78.6	0.01	9.8	2.0	2	-63.8	300	6.0	-2.6	22.7	25.3	-

$$E \text{ [dBuV/m]} = \text{EIRP [dBm]} - 20 \log(\text{Distance [m]}) + \text{Ground bounce [dB]} + 104.8 \text{ [dBuV/m]}$$

$$\text{EIRP [dBm]} = \text{Reading [dBm]} + \text{Cable loss [dB]} + \text{Attenuator Loss [dB]} + \text{Antenna gain [dBi]} + 10 * \log(N)$$

N: Number of output

\*2.0 dBi was applied to the test result based on ANSI C63.10 since antenna gain was less than 2.0 dBi.

## Conducted Spurious Emission

Report No.	13004393S-A-R2
Test place	Shonan EMC Lab. No.3 Shielded Room
Date	September 23, 2019
Temperature / Humidity	24 deg. C / 42 % RH
Engineer	Hiromasa Sato
Mode	Tx BT LE 2402 MHz

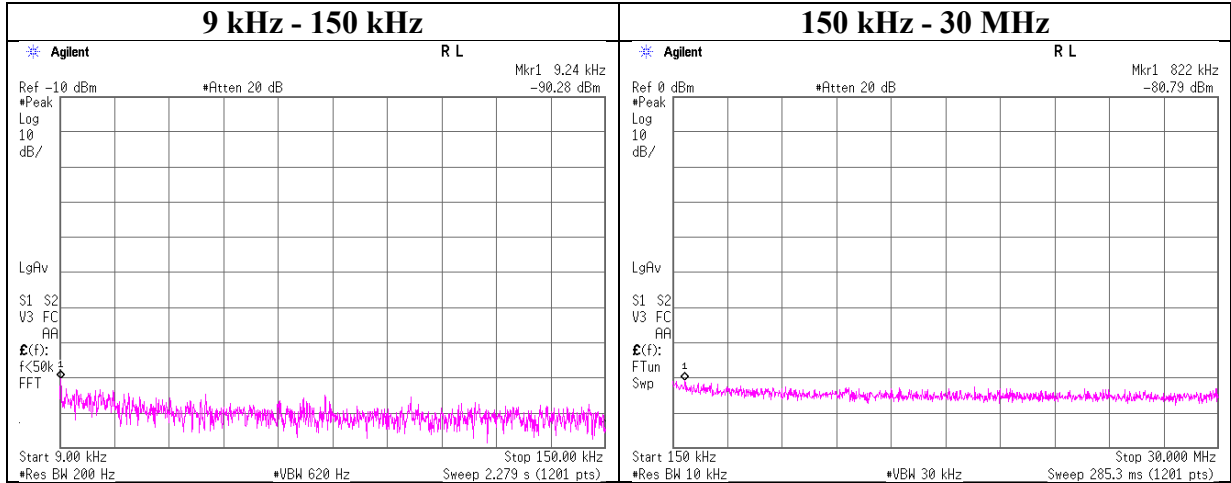

Frequency [kHz]	Reading [dBm]	Cable Loss [dB]	Attenuator Loss [dB]	Antenna Gain* [dBi]	N (Number of Output)	EIRP [dBm]	Distance [m]	Ground bounce [dB]	E (field strength) [dBuV/m]	Limit [dBuV/m]	Margin [dB]	Remark
9.24	-90.3	0.01	9.8	2.0	2	-75.4	300	6.0	-14.2	48.2	62.4	-
822.00	-80.8	0.01	9.8	2.0	2	-66.0	30	6.0	15.3	29.3	14.0	-

$$E \text{ [dBuV/m]} = \text{EIRP [dBm]} - 20 \log(\text{Distance [m]}) + \text{Ground bounce [dB]} + 104.8 \text{ [dBuV/m]}$$

$$\text{EIRP [dBm]} = \text{Reading [dBm]} + \text{Cable loss [dB]} + \text{Attenuator Loss [dB]} + \text{Antenna gain [dBi]} + 10 * \log(N)$$

N: Number of output

\*2.0 dBi was applied to the test result based on ANSI C63.10 since antenna gain was less than 2.0 dBi.

## Conducted Spurious Emission

Report No. 13004393S-A-R2  
Test place Shonan EMC Lab. No.3 Shielded Room  
Date September 23, 2019  
Temperature / Humidity 24 deg. C / 42 % RH  
Engineer Hiromasa Sato  
Mode Tx BT LE 2440 MHz

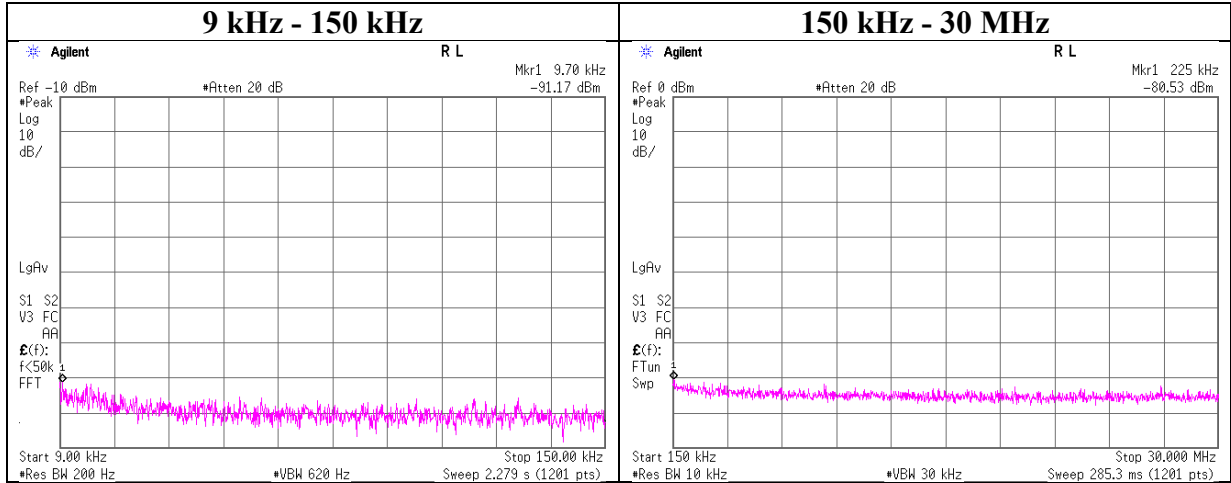

Frequency [kHz]	Reading [dBm]	Cable Loss [dB]	Attenuator Loss [dB]	Antenna Gain* [dBi]	N (Number of Output)	EIRP [dBm]	Distance [m]	Ground bounce [dB]	E (field strength) [dBuV/m]	Limit [dBuV/m]	Margin [dB]	Remark
9.70	-91.2	0.01	9.8	2.0	2	-76.3	300	6.0	-15.1	47.8	62.9	-
225.00	-80.5	0.01	9.8	2.0	2	-65.7	300	6.0	-4.4	20.5	24.9	-

$$E \text{ [dBuV/m]} = \text{EIRP [dBm]} - 20 \log(\text{Distance [m]}) + \text{Ground bounce [dB]} + 104.8 \text{ [dBuV/m]}$$

$$\text{EIRP[dBm]} = \text{Reading [dBm]} + \text{Cable loss [dB]} + \text{Attenuator Loss [dB]} + \text{Antenna gain [dBi]} + 10 * \log(N)$$

N: Number of output

\*2.0 dBi was applied to the test result based on ANSI C63.10 since antenna gain was less than 2.0 dBi.



## Conducted Spurious Emission

Report No. 13004393S-A-R2  
 Test place Shonan EMC Lab. No.3 Shielded Room  
 Date September 23, 2019  
 Temperature / Humidity 24 deg. C / 42 % RH  
 Engineer Hiromasa Sato  
 Mode Tx BT LE 2480 MHz

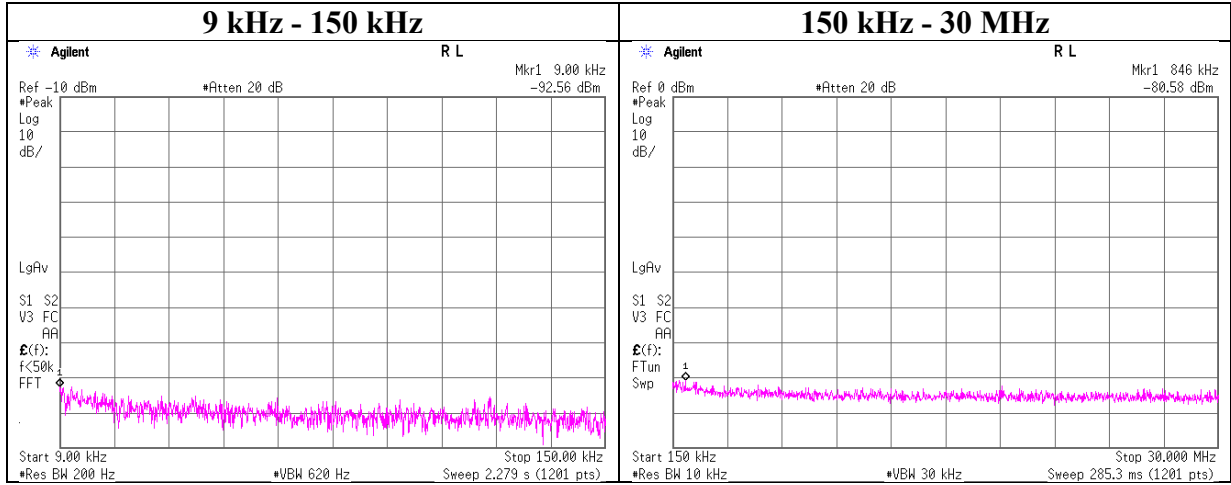

Frequency [kHz]	Reading [dBm]	Cable Loss [dB]	Attenuator Loss [dB]	Antenna Gain* [dBi]	N (Number of Output)	EIRP [dBm]	Distance [m]	Ground bounce [dB]	E (field strength) [dBuV/m]	Limit [dBuV/m]	Margin [dB]	Remark
9.00	-92.6	0.01	9.8	2.0	2	-77.7	300	6.0	-16.5	48.5	65.0	-
846.00	-80.6	0.01	9.8	2.0	2	-65.7	30	6.0	15.5	29.0	13.5	-

$$E \text{ [dBuV/m]} = \text{EIRP [dBm]} - 20 \log(\text{Distance [m]}) + \text{Ground bounce [dB]} + 104.8 \text{ [dBuV/m]}$$

$$\text{EIRP [dBm]} = \text{Reading [dBm]} + \text{Cable loss [dB]} + \text{Attenuator Loss [dB]} + \text{Antenna gain [dBi]} + 10 * \log(N)$$

N: Number of output

\*2.0 dBi was applied to the test result based on ANSI C63.10 since antenna gain was less than 2.0 dBi.

## Power Density

Report No. 13004393S-A-R2  
Test place Shonan EMC Lab. No.3 Shielded Room  
Date September 10, 2019  
Temperature / Humidity 25 deg. C / 53 % RH  
Engineer Takahiro Kawakami  
Mode Tx 11b, high power  
EUT Serial No. A-1

### Antenna 1 + Antenna 2

Freq. [MHz]	Antenna 1 (Chain 0) Result [mW]	Antenna 2 (Chain 1) Result [mW]	Result		Limit [dBm]	Margin [dB]
			[dBm]	[mW]		
2412	0.17	0.15	-4.98	0.32	8.00	12.98
2437	0.12	0.17	-5.42	0.29	8.00	13.42
2462	0.16	0.17	-4.87	0.33	8.00	12.87

Sample Calculation:

Result = Antenna 1 [mW] + Antenna 2 [mW]

### Antenna 1 (Chain 0)

Freq. [MHz]	Reading [dBm]	Cable Loss [dB]	Atten. Loss [dB]	Result		Limit [dBm]	Margin [dB]
				[dBm]	[mW]		
2412	-19.85	2.27	9.82	-7.76	0.17	8.00	15.76
2437	-21.33	2.30	9.82	-9.21	0.12	8.00	17.21
2462	-20.06	2.31	9.82	-7.93	0.16	8.00	15.93

### Antenna 2 (Chain 1)

Freq. [MHz]	Reading [dBm]	Cable Loss [dB]	Atten. Loss [dB]	Result		Limit [dBm]	Margin [dB]
				[dBm]	[mW]		
2412	-20.80	2.39	10.18	-8.23	0.15	8.00	16.23
2437	-20.37	2.41	10.18	-7.78	0.17	8.00	15.78
2462	-20.41	2.41	10.18	-7.82	0.17	8.00	15.82

Sample Calculation:

Result = Reading + Cable Loss (including the cable(s) customer supplied) + Attenuator Loss

## Power Density

Report No. 13004393S-A-R2  
Test place Shonan EMC Lab. No.3 Shielded Room  
Date September 10, 2019  
Temperature / Humidity 25 deg. C / 53 % RH  
Engineer Takahiro Kawakami  
Mode Tx 11g, high power  
EUT Serial No. A-1

### Antenna 1 + Antenna 2

Freq. [MHz]	Antenna 1 (Chain 0)	Antenna 2 (Chain 1)	Result		Limit [dBm]	Margin [dB]
	Result [mW]	Result [mW]	[dBm]	[mW]		
2412	0.07	0.07	-8.55	0.14	8.00	16.55
2437	0.07	0.07	-8.70	0.13	8.00	16.70
2462	0.06	0.08	-8.34	0.15	8.00	16.34

Sample Calculation:

Result = Antenna 1 [mW] + Antenna 2 [mW]

### Antenna 1 (Chain 0)

Freq. [MHz]	Reading [dBm]	Cable Loss [dB]	Atten. Loss [dB]	Result		Limit [dBm]	Margin [dB]
				[dBm]	[mW]		
2412	-23.78	2.27	9.82	-11.69	0.07	8.00	19.69
2437	-23.92	2.30	9.82	-11.80	0.07	8.00	19.80
2462	-24.10	2.31	9.82	-11.97	0.06	8.00	19.97

### Antenna 2 (Chain 1)

Freq. [MHz]	Reading [dBm]	Cable Loss [dB]	Atten. Loss [dB]	Result		Limit [dBm]	Margin [dB]
				[dBm]	[mW]		
2412	-24.00	2.39	10.18	-11.43	0.07	8.00	19.43
2437	-24.22	2.41	10.18	-11.63	0.07	8.00	19.63
2462	-23.40	2.41	10.18	-10.81	0.08	8.00	18.81

Sample Calculation:

Result = Reading + Cable Loss (including the cable(s) customer supplied) + Attenuator Loss

## Power Density

Report No. 13004393S-A-R2  
Test place Shonan EMC Lab. No.3 Shielded Room  
Date September 11, 2019  
Temperature / Humidity 24 deg. C / 58 % RH  
Engineer Takahiro Kawakami  
Mode Tx 11n-20 CDD, high power  
EUT Serial No. A-1

### Antenna 1 + Antenna 2

Freq. [MHz]	Antenna 1 (Chain 0) Result [mW]	Antenna 2 (Chain 1) Result [mW]	Result		Limit [dBm]	Margin [dB]
			[dBm]	[mW]		
2412	0.06	0.06	-9.15	0.12	8.00	17.15
2437	0.06	0.06	-9.17	0.12	8.00	17.17
2462	0.06	0.06	-9.32	0.12	8.00	17.32

Sample Calculation:

Result = Antenna 1 [mW] + Antenna 2 [mW]

### Antenna 1 (Chain 0)

Freq. [MHz]	Reading [dBm]	Cable Loss [dB]	Atten. Loss [dB]	Result		Limit [dBm]	Margin [dB]
				[dBm]	[mW]		
2412	-24.36	2.27	9.82	-12.27	0.06	8.00	20.27
2437	-24.46	2.30	9.82	-12.34	0.06	8.00	20.34
2462	-24.63	2.31	9.82	-12.50	0.06	8.00	20.50

### Antenna 2 (Chain 1)

Freq. [MHz]	Reading [dBm]	Cable Loss [dB]	Atten. Loss [dB]	Result		Limit [dBm]	Margin [dB]
				[dBm]	[mW]		
2412	-24.63	2.39	10.18	-12.06	0.06	8.00	20.06
2437	-24.61	2.41	10.18	-12.02	0.06	8.00	20.02
2462	-24.76	2.41	10.18	-12.17	0.06	8.00	20.17

Sample Calculation:

Result = Reading + Cable Loss (including the cable(s) customer supplied) + Attenuator Loss

## Power Density

Report No. 13004393S-A-R2  
Test place Shonan EMC Lab. No.3 Shielded Room  
Date September 10, 2019  
Temperature / Humidity 25 deg. C / 53 % RH  
Engineer Takahiro Kawakami  
Mode Tx 11n-20 MIMO, high power  
EUT Serial No. A-1

### Antenna 1 + Antenna 2

Freq. [MHz]	Antenna 1 (Chain 0)	Antenna 2 (Chain 1)	Result		Limit [dBm]	Margin [dB]
	Result [mW]	Result [mW]	[dBm]	[mW]		
2412	0.06	0.06	-9.55	0.11	8.00	17.55
2437	0.06	0.06	-9.01	0.13	8.00	17.01
2462	0.06	0.06	-9.27	0.12	8.00	17.27

Sample Calculation:

Result = Antenna 1 [mW] + Antenna 2 [mW]

### Antenna 1 (Chain 0)

Freq. [MHz]	Reading [dBm]	Cable Loss [dB]	Atten. Loss [dB]	Result		Limit [dBm]	Margin [dB]
				[dBm]	[mW]		
2412	-24.67	2.27	9.82	-12.58	0.06	8.00	20.58
2437	-24.28	2.30	9.82	-12.16	0.06	8.00	20.16
2462	-24.60	2.31	9.82	-12.47	0.06	8.00	20.47

### Antenna 2 (Chain 1)

Freq. [MHz]	Reading [dBm]	Cable Loss [dB]	Atten. Loss [dB]	Result		Limit [dBm]	Margin [dB]
				[dBm]	[mW]		
2412	-25.12	2.39	10.18	-12.55	0.06	8.00	20.55
2437	-24.48	2.41	10.18	-11.89	0.06	8.00	19.89
2462	-24.69	2.41	10.18	-12.10	0.06	8.00	20.10

Sample Calculation:

Result = Reading + Cable Loss (including the cable(s) customer supplied) + Attenuator Loss

**Power Density**

EUT Serial No. A-1

11b Antenna (Chain-0)

11b Antenna 2(Chain-1)

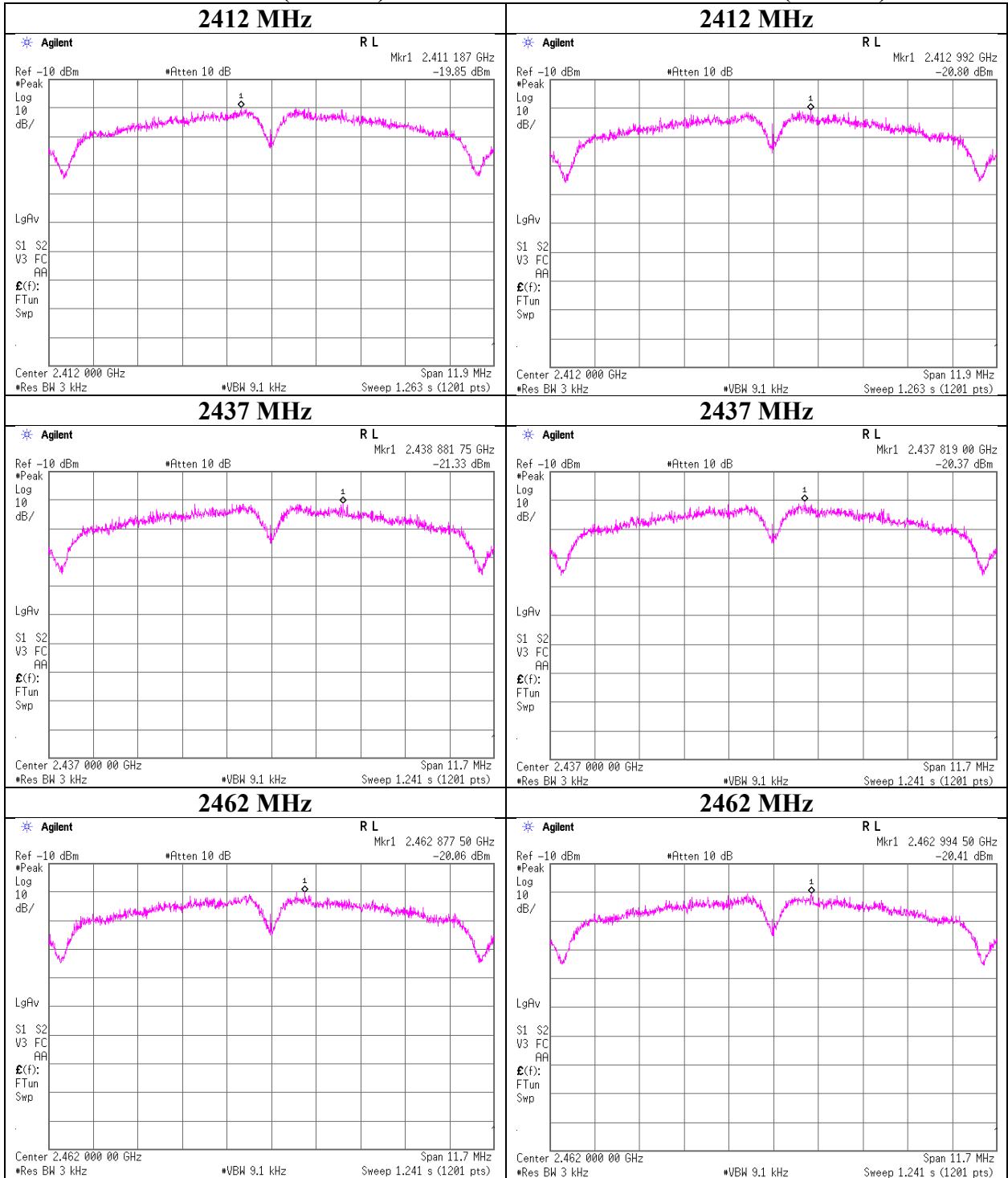

**UL Japan, Inc.**

**Shonan EMC Lab.**

1-22-3 Megumigaoka, Hiratsuka-shi, Kanagawa-ken, 259-1220 JAPAN

Telephone : +81 463 50 6400

Facsimile : +81 463 50 6401

**Power Density**

EUT Serial No. A-1

**11g Antenna (Chain-0)**

**11g Antenna 2(Chain-1)**

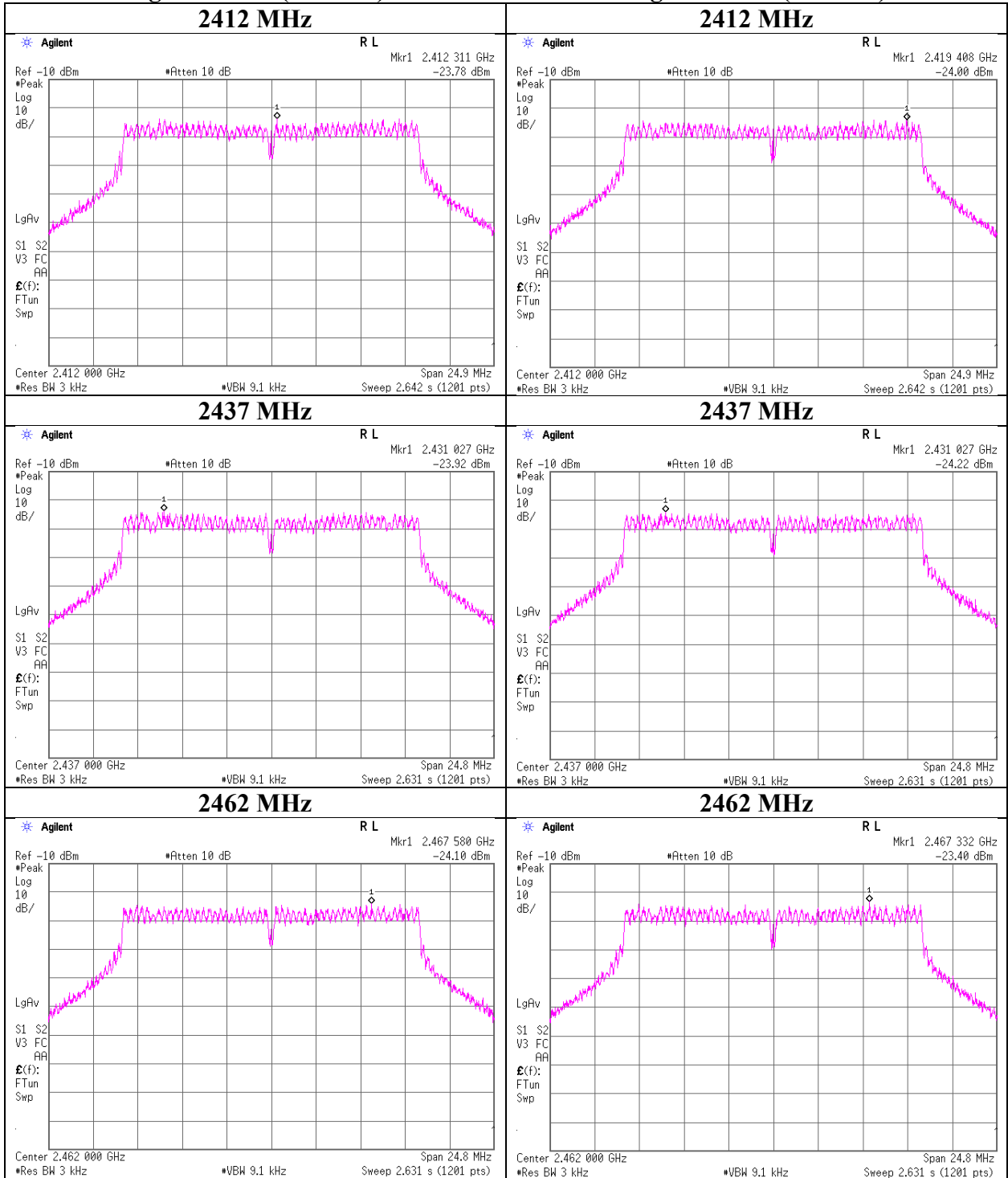

**UL Japan, Inc.**

**Shonan EMC Lab.**

1-22-3 Megumigaoka, Hiratsuka-shi, Kanagawa-ken, 259-1220 JAPAN

Telephone : +81 463 50 6400

Facsimile : +81 463 50 6401

**Power Density**

**EUT Serial No. A-1**

**11n-20 CDD Antenna1 (Chain-0)**

**11n-20 CDD Antenna 2(Chain-1)**

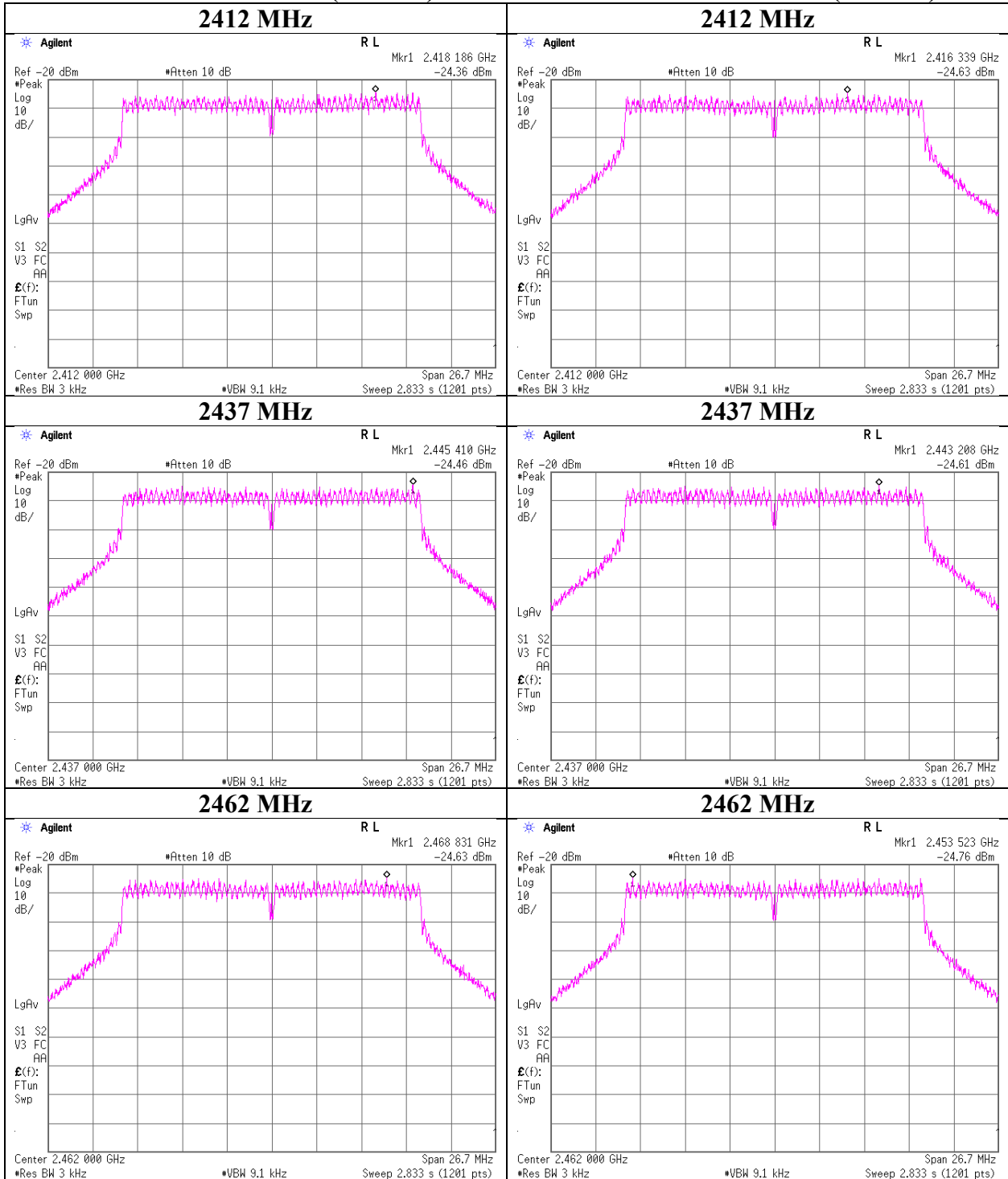

**UL Japan, Inc.**

**Shonan EMC Lab.**

1-22-3 Megumigaoka, Hiratsuka-shi, Kanagawa-ken, 259-1220 JAPAN

Telephone : +81 463 50 6400

Facsimile : +81 463 50 6401



**Power Density**

**EUT Serial No. A-1**

**11n-20 MIMO Antenna1 (Chain-0)**

**11n-20 MIMO Antenna 2(Chain-1)**

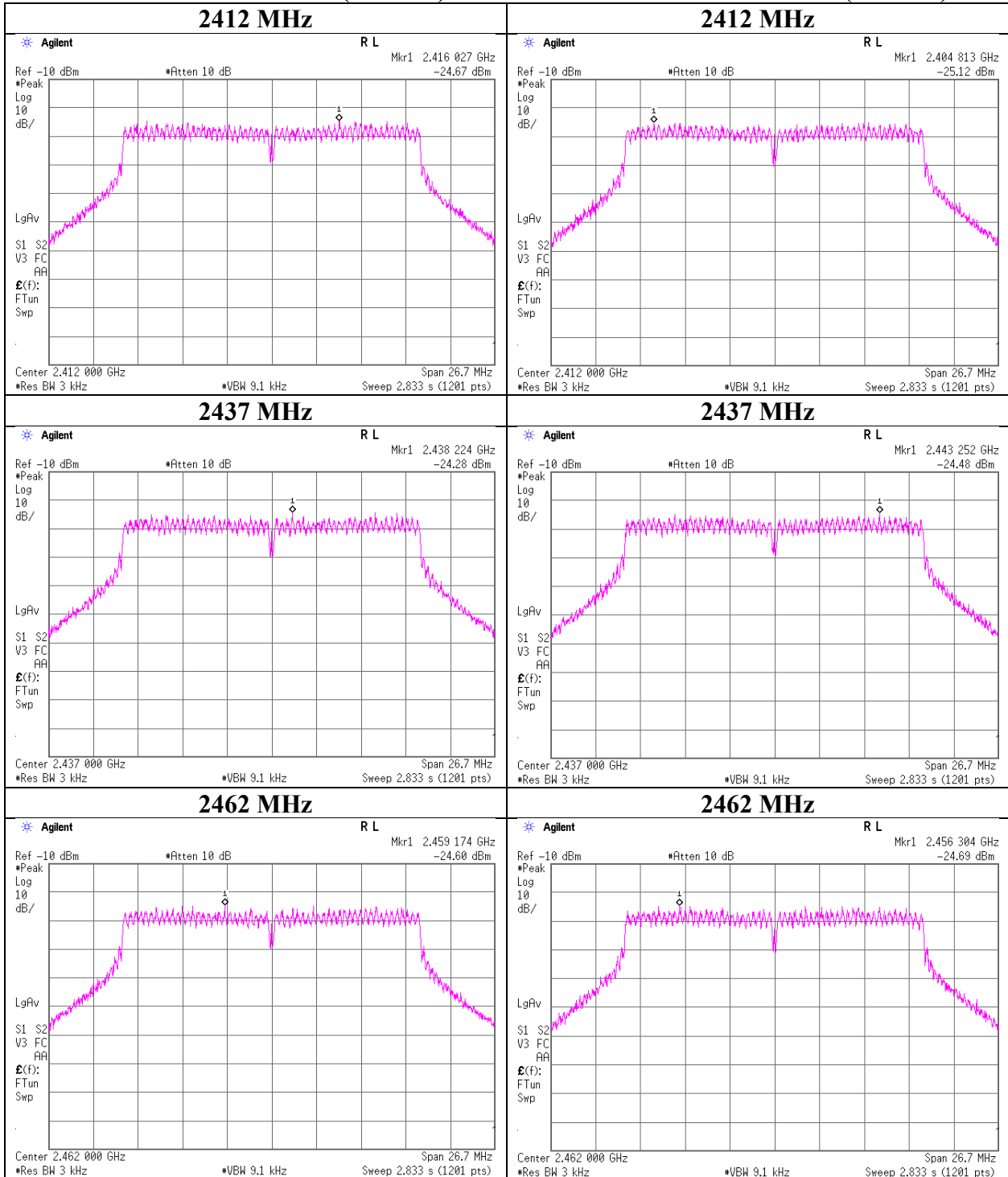

**UL Japan, Inc.**

**Shonan EMC Lab.**

1-22-3 Megumigaoka, Hiratsuka-shi, Kanagawa-ken, 259-1220 JAPAN

Telephone : +81 463 50 6400

Facsimile : +81 463 50 6401

## Power Density

Report No. 13004393S-A-R2  
Test place Shonan EMC Lab. No.3 Shielded Room  
Date September 23, 2019  
Temperature / Humidity 24 deg. C / 42 % RH  
Engineer Hiromasa Sato  
Mode Tx 11b, high power  
EUT Serial No. B-2

### Antenna 1 + Antenna 2

Freq. [MHz]	Antenna 1 (Chain 0)	Antenna 2 (Chain 1)	Result		Limit [dBm]	Margin [dB]
	Result [mW]	Result [mW]	[dBm]	[mW]		
2412	0.15	0.18	-4.81	0.33	8.00	12.81
2437	0.16	0.17	-4.81	0.33	8.00	12.81
2462	0.15	0.17	-4.99	0.32	8.00	12.99

Sample Calculation:

Result = Antenna 1 [mW] + Antenna 2 [mW]

### Antenna 1 (Chain 0)

Freq. [MHz]	Reading [dBm]	Cable Loss [dB]	Atten. Loss [dB]	Result		Limit [dBm]	Margin [dB]
				[dBm]	[mW]		
2412	-20.44	2.27	9.82	-8.35	0.15	8.00	16.35
2437	-20.10	2.30	9.82	-7.98	0.16	8.00	15.98
2462	-20.45	2.31	9.82	-8.32	0.15	8.00	16.32

### Antenna 2 (Chain 1)

Freq. [MHz]	Reading [dBm]	Cable Loss [dB]	Atten. Loss [dB]	Result		Limit [dBm]	Margin [dB]
				[dBm]	[mW]		
2412	-20.00	2.47	10.18	-7.35	0.18	8.00	15.35
2437	-20.33	2.49	10.18	-7.66	0.17	8.00	15.66
2462	-20.38	2.49	10.18	-7.71	0.17	8.00	15.71

Sample Calculation:

Result = Reading + Cable Loss (including the cable(s) customer supplied) + Attenuator Loss

## Power Density

Report No. 13004393S-A-R2  
Test place Shonan EMC Lab. No.3 Shielded Room  
Date September 10, 2019  
Temperature / Humidity 25 deg. C / 53 % RH  
Engineer Takahiro Kawakami  
Mode Tx 11g, high power  
EUT Serial No. B-2

### Antenna 1 + Antenna 2

Freq. [MHz]	Antenna 1 (Chain 0)	Antenna 2 (Chain 1)	Result		Limit [dBm]	Margin [dB]
	Result [mW]	Result [mW]	[dBm]	[mW]		
2412	0.06	0.07	-8.90	0.13	8.00	16.90
2437	0.06	0.06	-9.07	0.12	8.00	17.07
2462	0.06	0.07	-9.09	0.12	8.00	17.09

Sample Calculation:

Result = Antenna 1 [mW] + Antenna 2 [mW]

### Antenna 1 (Chain 0)

Freq. [MHz]	Reading [dBm]	Cable Loss [dB]	Atten. Loss [dB]	Result		Limit [dBm]	Margin [dB]
				[dBm]	[mW]		
2412	-24.26	2.27	9.82	-12.17	0.06	8.00	20.17
2437	-24.29	2.30	9.82	-12.17	0.06	8.00	20.17
2462	-24.48	2.31	9.82	-12.35	0.06	8.00	20.35

### Antenna 2 (Chain 1)

Freq. [MHz]	Reading [dBm]	Cable Loss [dB]	Atten. Loss [dB]	Result		Limit [dBm]	Margin [dB]
				[dBm]	[mW]		
2412	-24.32	2.47	10.18	-11.67	0.07	8.00	19.67
2437	-24.66	2.49	10.18	-11.99	0.06	8.00	19.99
2462	-24.54	2.49	10.18	-11.87	0.07	8.00	19.87

Sample Calculation:

Result = Reading + Cable Loss (including the cable(s) customer supplied) + Attenuator Loss

## Power Density

Report No. 13004393S-A-R2  
Test place Shonan EMC Lab. No.3 Shielded Room  
Date September 11, 2019  
Temperature / Humidity 24 deg. C / 58 % RH  
Engineer Takahiro Kawakami  
Mode Tx 11n-20 CDD, high power  
EUT Serial No. B-2

### Antenna 1 + Antenna 2

Freq. [MHz]	Antenna 1 (Chain 0)	Antenna 2 (Chain 1)	Result		Limit [dBm]	Margin [dB]
	Result [mW]	Result [mW]	[dBm]	[mW]		
2412	0.07	0.06	-8.86	0.13	8.00	16.86
2437	0.06	0.06	-9.27	0.12	8.00	17.27
2462	0.06	0.07	-9.07	0.12	8.00	17.07

Sample Calculation:

Result = Antenna 1 [mW] + Antenna 2 [mW]

### Antenna 1 (Chain 0)

Freq. [MHz]	Reading	Cable Loss [dB]	Atten. Loss [dB]	Result		Limit [dBm]	Margin [dB]
	[dBm]			[dBm]	[mW]		
2412	-23.96	2.27	9.82	-11.87	0.07	8.00	19.87
2437	-24.54	2.30	9.82	-12.42	0.06	8.00	20.42
2462	-24.68	2.31	9.82	-12.55	0.06	8.00	20.55

### Antenna 2 (Chain 1)

Freq. [MHz]	Reading	Cable Loss [dB]	Atten. Loss [dB]	Result		Limit [dBm]	Margin [dB]
	[dBm]			[dBm]	[mW]		
2412	-24.53	2.47	10.18	-11.88	0.06	8.00	19.88
2437	-24.81	2.49	10.18	-12.14	0.06	8.00	20.14
2462	-24.33	2.49	10.18	-11.66	0.07	8.00	19.66

Sample Calculation:

Result = Reading + Cable Loss (including the cable(s) customer supplied) + Attenuator Loss

## Power Density

Report No. 13004393S-A-R2  
Test place Shonan EMC Lab. No.3 Shielded Room  
Date September 10, 2019  
Temperature / Humidity 25 deg. C / 53 % RH  
Engineer Takahiro Kawakami  
Mode Tx 11n-20 MIMO, high power  
EUT Serial No. B-2

### Chain0 + 1

Freq. [MHz]	Antenna 1 (Chain 0)	Antenna 2 (Chain 1)	Result		Limit [dBm]	Margin [dB]
	Result [mW]	Result [mW]	[dBm]	[mW]		
2412	0.07	0.08	-8.35	0.15	8.00	16.35
2437	0.06	0.08	-8.36	0.15	8.00	16.36
2462	0.06	0.08	-8.42	0.14	8.00	16.42

Sample Calculation:

Result = Antenna 1 [mW] + Antenna 2 [mW]

### Chain0

Freq. [MHz]	Reading	Cable Loss [dB]	Atten. Loss [dB]	Result		Limit [dBm]	Margin [dB]
	[dBm]			[dBm]	[mW]		
2412	-23.85	2.27	9.82	-11.76	0.07	8.00	19.76
2437	-24.18	2.30	9.82	-12.06	0.06	8.00	20.06
2462	-24.21	2.31	9.82	-12.08	0.06	8.00	20.08

### Chain1

Freq. [MHz]	Reading	Cable Loss [dB]	Atten. Loss [dB]	Result		Limit [dBm]	Margin [dB]
	[dBm]			[dBm]	[mW]		
2412	-23.64	2.47	10.18	-10.99	0.08	8.00	18.99
2437	-23.45	2.49	10.18	-10.78	0.08	8.00	18.78
2462	-23.53	2.49	10.18	-10.86	0.08	8.00	18.86

Sample Calculation:

Result = Reading + Cable Loss (including the cable(s) customer supplied) + Attenuator Loss

**Power Density**

**EUT Serial No. B-2**

**11b Antenna (Chain-0)**

**11b Antenna 2(Chain-1)**

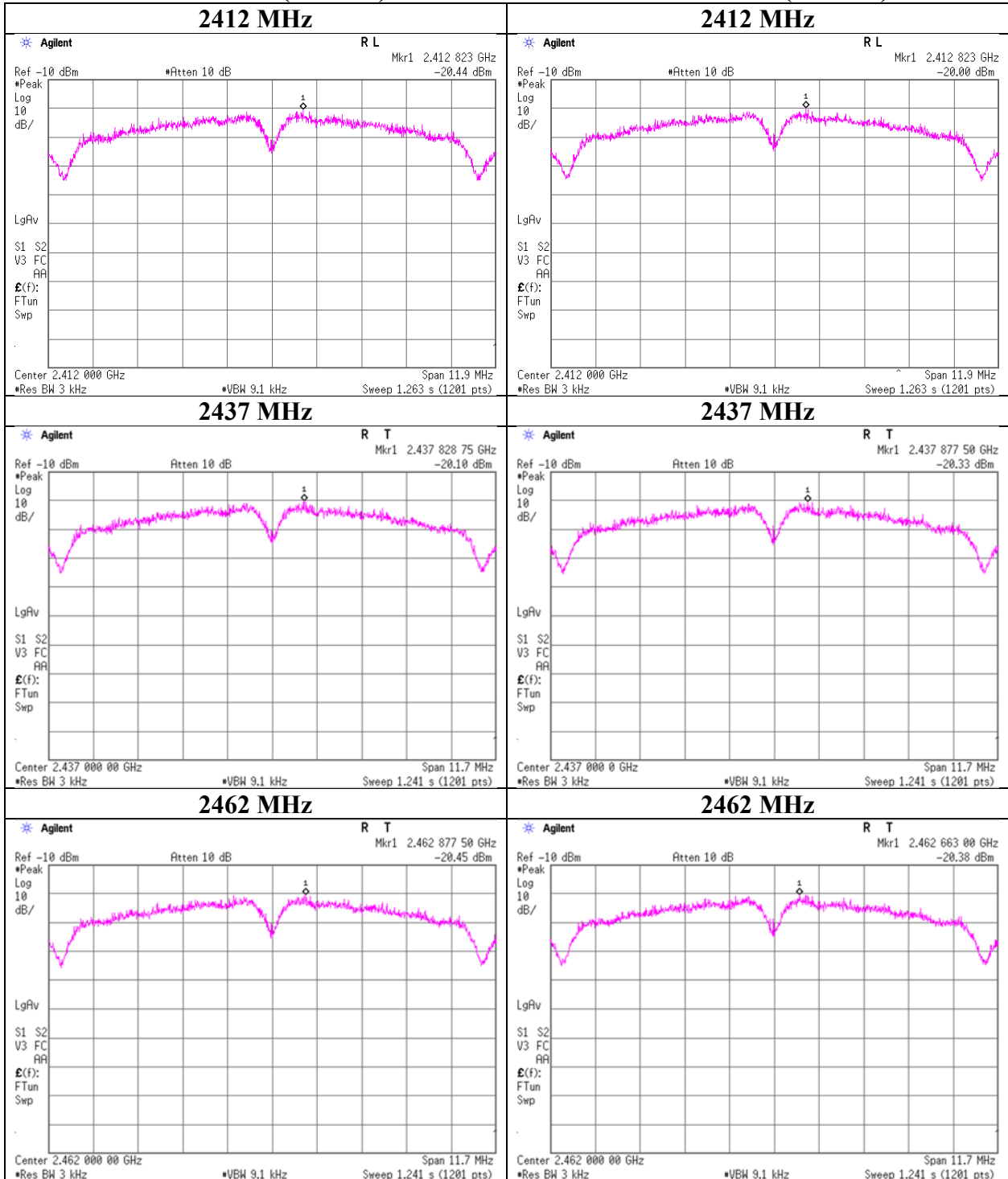

**UL Japan, Inc.**

**Shonan EMC Lab.**

1-22-3 Megumigaoka, Hiratsuka-shi, Kanagawa-ken, 259-1220 JAPAN

Telephone : +81 463 50 6400

Facsimile : +81 463 50 6401

**Power Density**

EUT Serial No. B-2

**11g Antenna (Chain-0)**

**11g Antenna 2(Chain-1)**

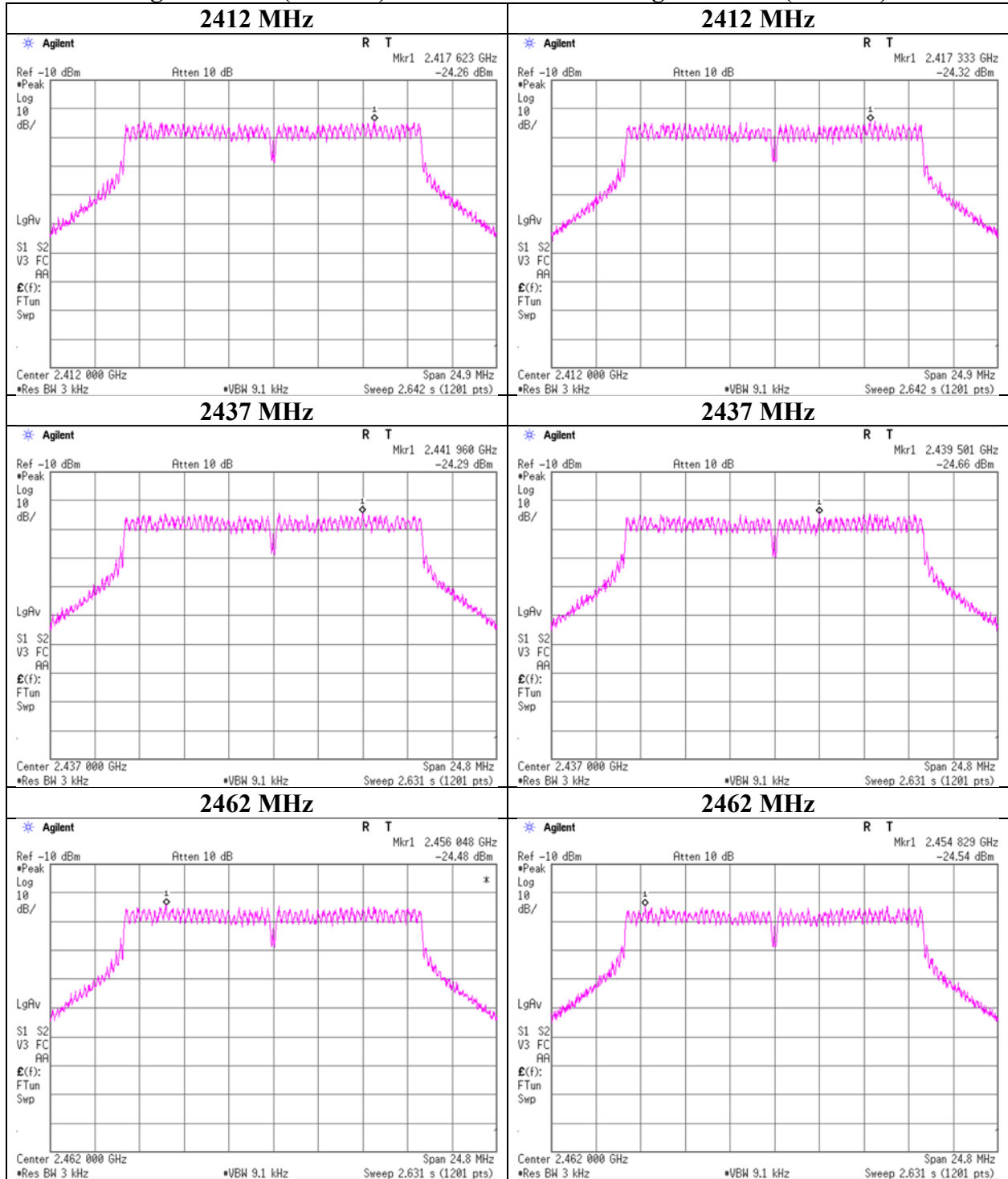

**UL Japan, Inc.**

**Shonan EMC Lab.**

1-22-3 Megumigaoka, Hiratsuka-shi, Kanagawa-ken, 259-1220 JAPAN

Telephone : +81 463 50 6400

Facsimile : +81 463 50 6401

**Power Density**

**EUT Serial No. B-2**

**11n-20 CDD Antenna1 (Chain-0)**

**11n-20 CDD Antenna 2(Chain-1)**

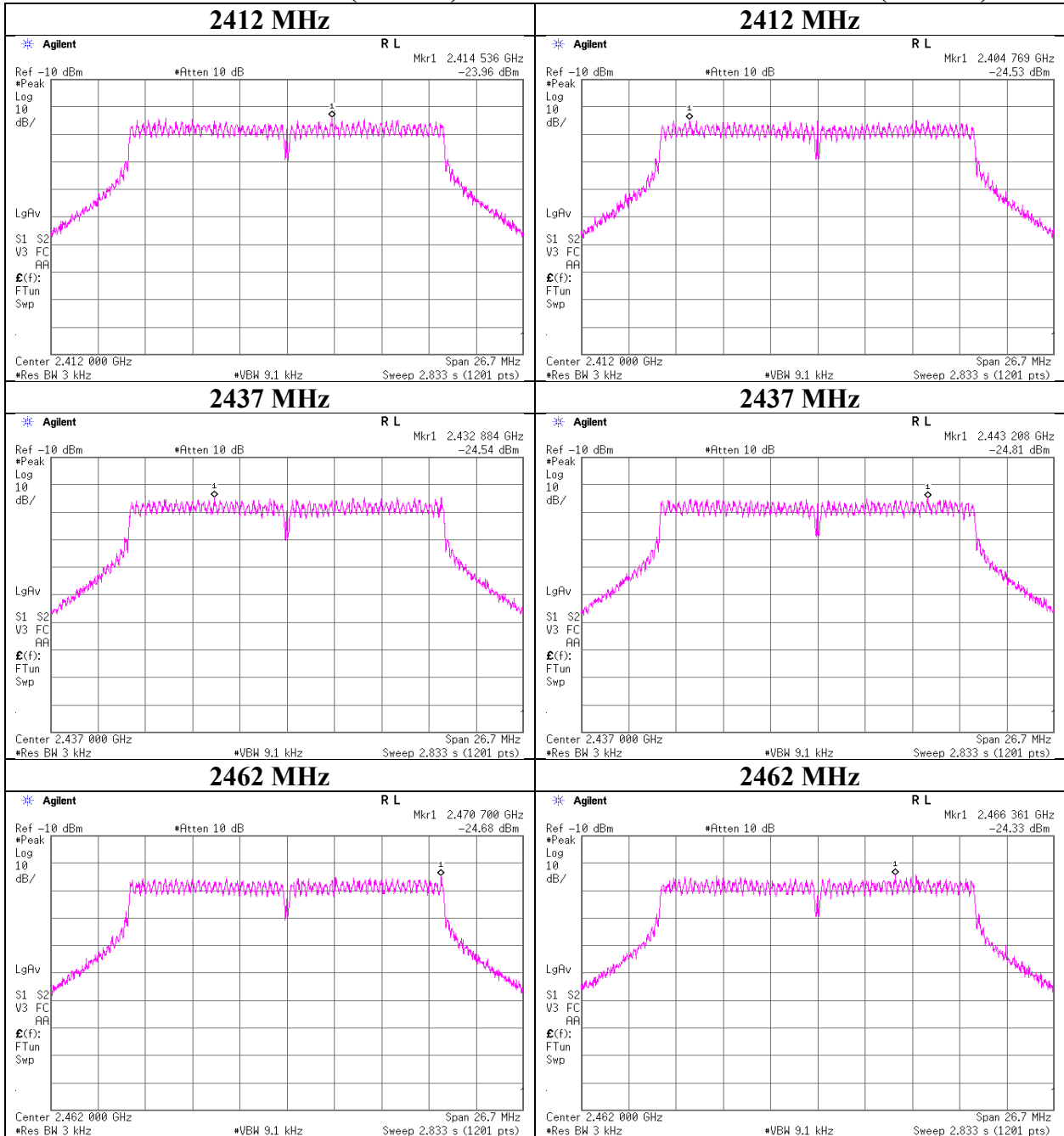

**UL Japan, Inc.**

**Shonan EMC Lab.**

1-22-3 Megumigaoka, Hiratsuka-shi, Kanagawa-ken, 259-1220 JAPAN

Telephone : +81 463 50 6400

Facsimile : +81 463 50 6401



**Power Density**

**EUT Serial No. B-2**

**11n-20 MIMO Antenna1 (Chain-0)**

**11n-20 MIMO Antenna 2(Chain-1)**

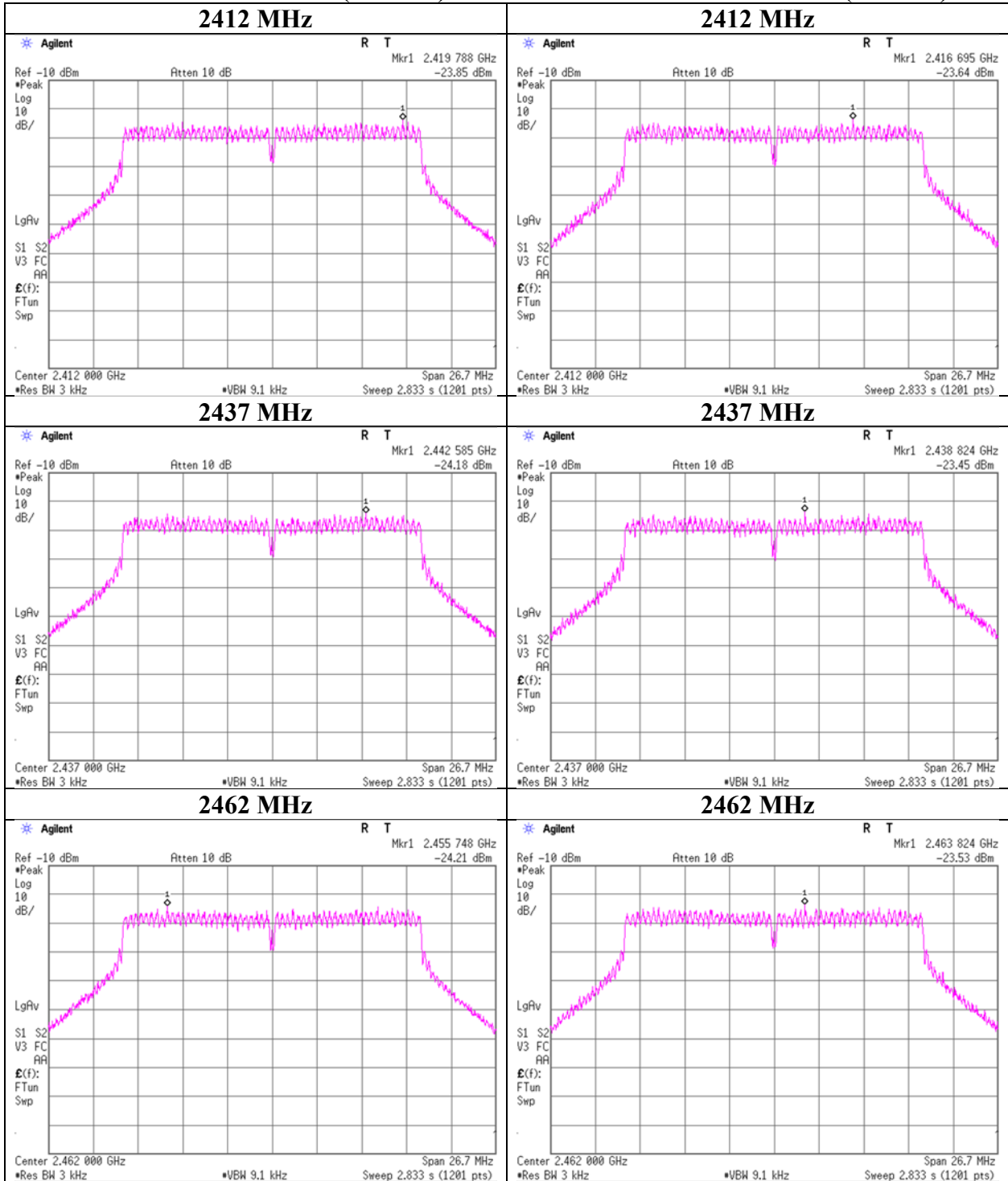

**UL Japan, Inc.**

**Shonan EMC Lab.**

1-22-3 Megumigaoka, Hiratsuka-shi, Kanagawa-ken, 259-1220 JAPAN

Telephone : +81 463 50 6400

Facsimile : +81 463 50 6401

### Power Density

Report No. 13004393S-A-R2  
Test place Shonan EMC Lab. No.3 Shielded Room  
Date September 23, 2019  
Temperature / Humidity 24 deg. C / 42 % RH  
Engineer Hiromasa Sato  
Mode Tx BT LE

#### BT LE

Freq. [MHz]	Reading [dBm]	Cable Loss [dB]	Atten. Loss [dB]	Result [dBm]	Limit [dBm]	Margin [dB]
2402	-16.15	1.32	9.92	-4.91	8.00	12.91
2440	-16.09	1.34	9.92	-4.83	8.00	12.83
2480	-16.10	1.33	9.92	-4.85	8.00	12.85

Sample Calculation:

Result = Reading + Cable Loss (including the cable(s) customer supplied) + Attenuator Loss

\*The equipment and cables were not used for factor 0 dB of the data sheets.

## Power Density

### BT LE

#### 2402 MHz

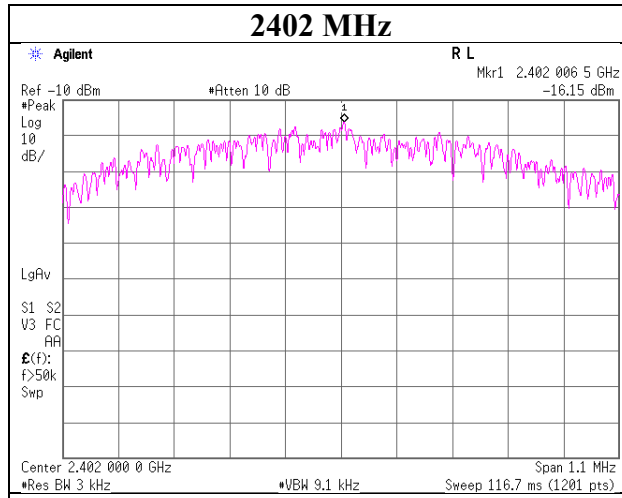

#### 2440 MHz

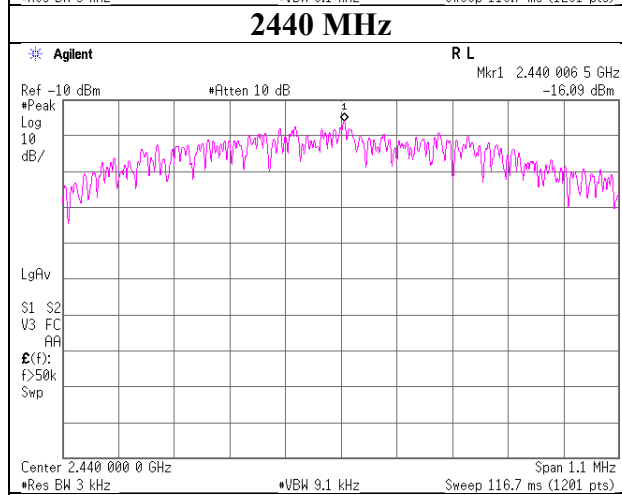

#### 2480 MHz

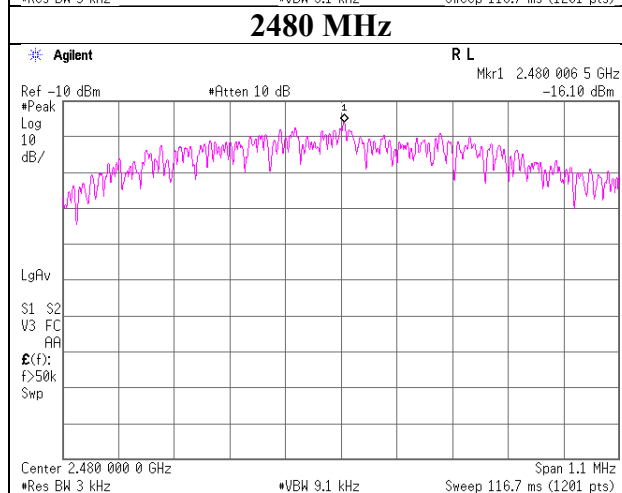

UL Japan, Inc.

Shonan EMC Lab.

1-22-3 Megumigaoka, Hiratsuka-shi, Kanagawa-ken, 259-1220 JAPAN

Telephone : +81 463 50 6400

Facsimile : +81 463 50 6401

## APPENDIX 2: Test instruments

### Test Instruments (1/2)

Local ID	Test Name	LIMS ID	Description	Manufacturer	Model	Serial	Last Calibration Date	Calibration Due Date	Calibration Interval (Month)
SAT10-13	AT	151610	Attenuator	Weinschel Corp.	54A-10	81626	2019/3/27	2020/3/31	12
SAT10-15	AT	160493	Attenuator	Weinschel Corp.	54A-10	83406	2018/12/6	2019/12/30	12
SCC-G13	AT	145166	Coaxial Cable	Suhner	SUCOFLEX 102	31599/2	2018/12/25	2019/12/31	12
SCC-G14	AT	145175	Coaxial Cable	Suhner	SUCOFLEX 102	31600/2	2018/12/25	2019/12/31	12
SCC-H14	AT	144995	Microwave cable	RS Pro	R-132G7210 100CO	-	2019/4/16	2020/4/30	12
SCC-H15	AT	144996	Microwave cable	RS Pro	R-132G7210 100CO	-	2019/4/16	2020/4/30	12
SOS-16	AT	167990	Humidity Indicator	CUSTOM	CTH-202	708Q08R	2019/1/11	2020/1/31	12
SPM-07	AT	146247	Power Meter	AGILENT	8990B	MY510027 2	2019/7/16	2020/7/31	12
SPM-13	AT	169910	Power Meter	EMC Instruments Corporation	8990B	MY510004 48	2019/3/6	2020/3/31	12
SPSS-04	AT	146310	Power sensor	AGILENT	N1923A	MY532600 9	2019/7/16	2020/7/31	12
SPSS-05	AT	146311	Power sensor	AGILENT	N1923A	MY534900 8	2019/7/16	2020/7/31	12
SPSS-06	AT	169911	Power sensor	EMC Instruments Corporation	N1923A	MY572700 04	2019/3/6	2020/3/31	12
SPSS-07	AT	169912	Power sensor	EMC Instruments Corporation	N1923A	MY572900 05	2019/3/6	2020/3/31	12
SRENT-15	AT	160899	Spectrum Analyzer	AGILENT (KEYSIGHT)	E4440A	MY461855 16	2019/1/21	2020/1/31	12
SSA-01	AT	146223	Spectrum Analyzer	AGILENT	N9010A-526	MY480314 82	2019/4/23	2020/4/30	12
STS-04	AT	146211	Digital Hitester	HIOKI	3805-50	80997827	2019/4/2	2020/4/30	12
STR-08	AT,CE, RE	150463	Test Receiver	Rohde & Schwarz	ESW44	101581	2018/11/28	2019/11/30	12
SAT3-10	CE	144960	Attenuator	JFW	50HF-003N	-	2019/8/6	2020/8/31	12
SCC-C6/C7/C8/C10/SRSE-03	CE	145034	Coaxial Cable&RF Selector	Suhner/Fujikura /Suhner/Suhner/ TOYO	141PE/12DSF A/141PE/141 PE/NS4906	-/0901-271(RF Selector)	2019/4/19	2020/4/30	12
SLS-01	CE	145538	LISN	Rohde & Schwarz	ENV216	100511	2019/2/19	2020/2/29	12
SLS-05	CE	145542	LISN	Rohde & Schwarz	ENV216	100516	2019/2/19	2020/2/29	12
SOS-06	CE	146294	Humidity Indicator	A&D	AD-5681	4062118	2018/12/5	2019/12/31	12
STM-05	CE	145762	Terminator	TME	CT-01 BP	-	2018/12/25	2019/12/31	12

**Test Instruments (2/2)**

Local ID	Test Name	LIMS ID	Description	Manufacturer	Model	Serial	Last Calibration Date	Calibration Due Date	Calibration Interval (Month)
COTS-SEMI-5	CE,RE	170932	EMI Software	TSJ	TEPTO-DV3(RE,CE,ME,PE)	-	-	-	-
KJM-02	CE,RE	146432	Measure	TAJIMA	GL19-55	-	-	-	-
STS-03	CE,RE	146210	Digital Hitester	HIOKI	3805-50	80997823	2019/10/1	2020/10/31	12
KSA-08	RE	145089	Spectrum Analyzer	AGILENT	E4446A	MY46180525	2018/10/7	2019/10/31	12
SAEC-03(NSA)	RE	145565	Semi-Anechoic Chamber	TDK	SAEC-03(NSA)	3	2019/4/8	2020/4/30	12
SAEC-03(SVSWR)	RE	145566	Semi-Anechoic Chamber	TDK	SAEC-03(SVSWR)	3	2019/5/3	2020/5/31	12
SAF-03	RE	145126	Pre Amplifier	SONOMA	310N	290213	2019/2/5	2020/2/29	12
SAF-06	RE	145005	Pre Amplifier	Toyo Corporation	TPA0118-36	1440491	2019/2/8	2020/2/29	12
SAF-08	RE	145007	Pre Amplifier	Toyo Corporation	HAP18-26W	19	2019/3/5	2020/3/31	12
SAT10-06	RE	145137	Attenuator	AGILENT	8493C-010	74865	2018/11/25	2019/11/30	12
SAT6-13	RE	167094	Attenuator	JFW	50HF-006N	-	2019/2/5	2020/2/29	12
SBA-03	RE	145023	Biconical Antenna	Schwarzbeck	BBA9106	91032666	2019/5/7	2020/5/31	12
SCC-C1/C2/C3/C4/C5/C10/SRSE-03	RE	145171	Coaxial Cable&RF Selector	Fujikura/Fujikura/Suhner/Suhner/Suhner/Suhner/TOYO	8D2W/12DSFA/141PE/141PE/141PE/141P	-/0901-271(RF Selector)	2019/4/19	2020/4/30	12
SCC-G40	RE	166491	Coaxial Cable	Junkosha	MWX221-01000NFSN MS/B	1612S005	2019/1/25	2020/1/31	12
SCC-G43	RE	156380	Coaxial Cable	HUBER+SUNER	SUCOFLEX_104 E	SN MY 13406/4E	2019/7/3	2020/7/31	12
SCC-G45	RE	168301	Coaxial Cable	HUBER+SUNER	SUCOFLEX 102 E	800137/2EA	2019/3/26	2020/3/31	12
SCC-G57	RE	179540	Coaxial Cable	Huber+Suhner	SUCOFLEX 102	802815/2	2019/5/16	2020/5/31	12
SCC-G58	RE	183047	Coaxial Cable	HUBER+SUNER	SUCOFLEX 104	800287/4A	2019/7/23	2020/7/31	12
SHA-03	RE	145501	Horn Antenna	Schwarzbeck	BBHA9120D	9120D-739	2019/6/26	2020/6/30	12
SHA-04	RE	145512	Horn Antenna	ETS LINDGREN	3160-09	00094868	2019/6/26	2020/6/30	12
SLA-07	RE	145529	Logperiodic Antenna	Schwarzbeck	VUSLP9111B	196	2019/5/7	2020/5/31	12
SOS-05	RE	146293	Humidity Indicator	A&D	AD-5681	4062518	2018/10/25	2019/10/31	12

\*Hyphens for Last Calibration Date, Calibration Due Date and Cal Int (month) are instruments that Calibration is not required (e.g. software), or instruments checked in advance before use.

The expiration date of the calibration is the end of the expired month.

All equipment is calibrated with valid calibrations. Each measurement data is traceable to the national or international standards.

As for some calibrations performed after the tested dates, those test equipment have been controlled by means of an unbroken chains of calibrations.

**Test item:**

- CE: Conducted Emission**
- RE: Radiated Emission**
- AT: Antenna Terminal Conducted test**

**UL Japan, Inc.**  
**Shonan EMC Lab.**

1-22-3 Megumigaoka, Hiratsuka-shi, Kanagawa-ken, 259-1220 JAPAN  
Telephone : +81 463 50 6400  
Facsimile : +81 463 50 6401