



RADIO TEST REPORT

Test Report No. : 12752904H-A-R1

Applicant : Murata Manufacturing Co., Ltd.
Type of Equipment : Gateway
Model No. : LBAC0ZZ1SU
FCC ID : VPYLB1SU
Test regulation : FCC Part 15 Subpart C: 2019
Test Result : Complied (Refer to SECTION 3.2)

1. This test report shall not be reproduced in full or partial, without the written approval of UL Japan, Inc.
2. The results in this report apply only to the sample tested.
3. This sample tested is in compliance with the above regulation.
4. The test results in this report are traceable to the national or international standards.
5. This test report covers Radio technical requirements. It does not cover administrative issues such as Manual or non-Radio test related Requirements. (if applicable)
6. The all test items in this test report are conducted by UL Japan, Inc. Ise EMC Lab.
7. This test report must not be used by the customer to claim product certification, approval, or endorsement by NVLAP, NIST, or any agency of the Federal Government.
8. The information provided from the customer for this report is identified in SECTION 1.
9. This report is a revised version of 12752904H-A. 12752904H-A is replaced with this report.

Date of test: March 28 to April 11, 2019

Representative test engineer: T. Shimada
 Takumi Shimada
 Engineer
 Consumer Technology Division

Approved by: Takayuki Shimada
 Takayuki Shimada
 Leader
 Consumer Technology Division



This laboratory is accredited by the NVLAP LAB CODE 200572-0, U.S.A. The tests reported herein have been performed in accordance with its terms of accreditation. *As for the range of Accreditation in NVLAP, you may refer to the WEB address, http://japan.ul.com/resources/emc_accruited/

- The testing in which "Non-accreditation" is displayed is outside the accreditation scopes in UL Japan.
 There is no testing item of "Non-accreditation".

UL Japan, Inc.
Ise EMC Lab.

4383-326 Asama-cho, Ise-shi, Mie-ken 516-0021 JAPAN
 Telephone : +81 596 24 8999
 Facsimile : +81 596 24 8124

REVISION HISTORY

Original Test Report No.: 12752904H-A

Revision	Test report No.	Date	Page revised	Contents
- (Original)	12752904H-A	April 25, 2019	-	-
1	12752904H-A-R1	July 22, 2019	P 1 and 6	Update of FCC version
1	12752904H-A-R1	July 22, 2019	P 11 and 12	Correction of Shield of list of cable for LAN Cable and USB Cable.
1	12752904H-A-R1	July 22, 2019	P18	Addition of chart data
1	12752904H-A-R1	July 22, 2019	P 26	Correction of unit

CONTENTS	PAGE
SECTION 1: Customer information.....	4
SECTION 2: Equipment under test (E.U.T.).....	4
SECTION 3: Test specification, procedures & results.....	6
SECTION 4: Operation of E.U.T. during testing.....	10
SECTION 5: Conducted Emission.....	13
SECTION 6: Radiated Spurious Emission	14
SECTION 7: Antenna Terminal Conducted Tests.....	16
APPENDIX 1: Test data	17
Conducted Emission	17
6 dB Bandwidth and 99 % Occupied Bandwidth.....	19
Maximum Peak Output Power	22
Average Output Power.....	23
Radiated Spurious Emission	25
Conducted Spurious Emission	31
Power Density	34
APPENDIX 2: Test instruments	36
APPENDIX 3: Photographs of test setup	37
Conducted Emission	37
Radiated Spurious Emission	38
Worst Case Position	39

SECTION 1: Customer information

Company Name : Murata Manufacturing Co., Ltd.
Address : 1-10-1 Higashikotari, Nagaokakyo-shi, Kyoto 617-8555 Japan
Telephone Number : +81-75-955-6736
Facsimile Number : +81-75-955-6634
Contact Person : Motoo Hayashi

The information provided from the customer is as follows;

- Applicant, Type of Equipment, Model No., FCC ID on the cover and other relevant pages
 - Operating/Test Mode(s) (Mode(s)) on all the relevant pages
 - SECTION 1: Customer information
 - SECTION 2: Equipment under test (E.U.T.)
 - SECTION 4: Operation of E.U.T. during testing
- * The laboratory is exempted from liability of any test results affected from the above information in SECTION 2 and 4.

SECTION 2: Equipment under test (E.U.T.)

2.1 Identification of E.U.T.

Type of Equipment : Gateway
Model No. : LBAC0ZZ1SU
Serial No. : Refer to SECTION 4.2
Rating : VBAT: Min 4.75 V / Typ. 5.0 V / Max. 5.25 V
Receipt Date of Sample : March 18, 2019
(Information from test lab.)
Country of Mass-production : Japan, China
Condition of EUT : Production prototype
(Not for Sale: This sample is equivalent to mass-produced items.)
Modification of EUT : No Modification by the test lab

2.2 Product Description

Model: LBAC0ZZ1SU (referred to as the EUT in this report) is a Gateway.

Radio Specification

Sub GHz *1)

Radio Type : Transceiver
Frequency of Operation : 902.5 MHz to 927.5 MHz
Modulation : GFSK
Antenna type : Whip Antenna
Antenna Gain : ANT1: 1.7 dBi (Antenna gain: 2.0 dBi , RF cable loss(150 mm): 0.3 dB)
: ANT2: 1.8 dBi (Antenna gain: 2.0 dBi , RF cable loss(100 mm): 0.2 dB)
Clock frequency (Maximum) : 24 MHz

WLAN

Radio Type : Transceiver
Frequency of Operation : 2412 MHz - 2462 MHz
Modulation : DSSS, OFDM
Bandwidth & Channel spacing : 20 MHz & 5 MHz
Antenna type : Inverse F Antenna
Antenna Gain : 0.0 dBi
Clock frequency (Maximum) : 26 MHz

*1) This test report applies to Sub GHz (902.5 MHz to 927.5 MHz) part.

SECTION 3: Test specification, procedures & results

3.1 Test Specification

Test Specification : FCC Part 15 Subpart C
FCC Part 15 final revised on July 19, 2019 and effective August 19, 2019
except 15.258

Title : FCC 47CFR Part15 Radio Frequency Device Subpart C Intentional Radiators
Section 15.207 Conducted limits
Section 15.247 Operation within the bands 902-928 MHz,
2400-2483.5 MHz, and 5725-5850 MHz

* The revisions made after testing date do not affect the test specification applied to the EUT.
* Also the EUT complies with FCC Part 15 Subpart B.

3.2 Procedures and results

Item	Test Procedure	Specification	Worst margin	Results	Remarks
Conducted Emission	FCC: ANSI C63.10-2013 6. Standard test methods	FCC: Section 15.207	QP 20.24 dB, 0.60702 MHz, L AV 20.24 dB, 0.60588 MHz, N	Complied a)	-
	IC: RSS-Gen 8.8	IC: RSS-Gen 8.8			
6dB Bandwidth	FCC: KDB 558074 D01 15.247 Meas Guidance v05r02	FCC: Section 15.247(a)(2)	See data.	Complied b)	Conducted
	IC: -	IC: RSS-247 5.2(a)			
Maximum Peak Output Power	FCC: KDB 558074 D01 15.247 Meas Guidance v05r02	FCC: Section 15.247(b)(3)	See data.	Complied c)	Conducted
	IC: RSS-Gen 6.12	IC: RSS-247 5.4(d)			
Power Density	FCC: KDB 558074 D01 15.247 Meas Guidance v05r02	FCC: Section 15.247(e)	See data.	Complied d)	Conducted
	IC: -	IC: RSS-247 5.2(b)			
Spurious Emission Restricted Band Edges	FCC: KDB 558074 D01 15.247 Meas Guidance v05r02	FCC: Section15.247(d)	0.5 dB 250.022 MHz, QP, Hori.	Complied# e), f)	Conducted (below 30 MHz)/ Radiated (above 30 MHz) *1)
	IC: RSS-Gen 6.13	IC: RSS-247 5.5 RSS-Gen 8.9 RSS-Gen 8.10			

Note: UL Japan, Inc.'s EMI Work Procedures No. 13-EM-W0420 and 13-EM-W0422.

*1) Radiated test was selected over 30 MHz based on section 15.247(d) and KDB 558074 D01 15.247 Meas Guidance v05r02 8.5 and 8.6.

- a) Refer to APPENDIX 1 (data of Conducted Emission)
- b) Refer to APPENDIX 1 (data of 6 dB Bandwidth and 99 % Occupied Bandwidth)
- c) Refer to APPENDIX 1 (data of Maximum Peak Output Power)
- d) Refer to APPENDIX 1 (data of Power Density)
- e) Refer to APPENDIX 1 (data of Conducted Spurious Emission)
- f) Refer to APPENDIX 1 (data of Radiated Spurious Emission)

Symbols:

Complied The data of this test item has enough margin, more than the measurement uncertainty.
Complied# The data of this test item meets the limits unless the measurement uncertainty is taken into consideration.

* In case any questions arise about test procedure, ANSI C63.10: 2013 is also referred.

FCC Part 15.31 (e)

This EUT provides stable voltage constantly to RF Module regardless of input voltage. Therefore, this EUT complies with the requirement.

FCC Part 15.203 Antenna requirement

The EUT has a unique coupling/antenna connector (Unique connector: R-SMA). Therefore the equipment complies with the requirement of 15.203.

3.3 Addition to standard

Item	Test Procedure	Specification	Worst margin	Results	Remarks
99% Occupied Bandwidth	RSS-Gen 6.7	IC: -	N/A	- a)	Conducted

a) Refer to APPENDIX 1 (data of 6 dB Bandwidth and 99 % Occupied Bandwidth)

Other than above, no addition, exclusion nor deviation has been made from the standard.

3.4 Uncertainty

EMI

There is no applicable rule of uncertainty in this applied standard. Therefore, the following results are derived depending on whether or not laboratory uncertainty is applied.

The following uncertainties have been calculated to provide a confidence level of 95 % using a coverage factor $k=2$.
Ise EMC Lab.

Antenna Terminal test

Test Item	Uncertainty (+/-)
20 dB Bandwidth / 99 % Occupied Bandwidth	0.96 %
Maximum Peak Output Power / Average Output Power	1.3 dB
Carrier Frequency Separation	0.42 %
Dwell time / Burst rate	0.10 %
Conducted Spurious Emission	2.7 dB

Conducted emission

using Item	Frequency range	Uncertainty (+/-)
AMN (LISN)	0.009 MHz to 0.15 MHz	3.8 dB
	0.15 MHz to 30 MHz	3.4 dB

Radiated emission

Measurement distance	Frequency range	Uncertainty (+/-)
3 m	9 kHz to 30 MHz	3.3 dB
10 m		3.2 dB
3 m	30 MHz to 200 MHz (Horizontal) (Vertical)	4.8 dB
		5.0 dB
	200 MHz to 1000 MHz (Horizontal) (Vertical)	5.2 dB
		6.3 dB
10 m	30 MHz to 200 MHz (Horizontal) (Vertical)	4.8 dB
		4.9 dB
	200 MHz to 1000 MHz (Horizontal) (Vertical)	5.0 dB
		5.0 dB
3 m	1 GHz to 6 GHz	5.0 dB
	6 GHz to 18 GHz	5.3 dB
1 m	10 GHz to 26.5 GHz	5.8 dB
	26.5 GHz to 40 GHz	5.8 dB
10 m	1 GHz to 18 GHz	5.2 dB

3.5 Test Location

UL Japan, Inc. Ise EMC Lab.
 4383-326 Asama-cho, Ise-shi, Mie-ken 516-0021 JAPAN
 Telephone: +81 596 24 8999, Facsimile: +81 596 24 8124
 NVLAP Lab. code: 200572-0 / FCC Test Firm Registration Number: 199967

Test site	IC Registration Number	Width x Depth x Height (m)	Size of reference ground plane (m) / horizontal conducting plane	Other rooms	Maximum measurement distance
No.1 semi-anechoic chamber	2973C-1	19.2 x 11.2 x 7.7	7.0 x 6.0	No.1 Power source room	10 m
No.2 semi-anechoic chamber	2973C-2	7.5 x 5.8 x 5.2	4.0 x 4.0	-	3 m
No.3 semi-anechoic chamber	2973C-3	12.0 x 8.5 x 5.9	6.8 x 5.75	No.3 Preparation room	3 m
No.3 shielded room	-	4.0 x 6.0 x 2.7	N/A	-	-
No.4 semi-anechoic chamber	2973C-4	12.0 x 8.5 x 5.9	6.8 x 5.75	No.4 Preparation room	3 m
No.4 shielded room	-	4.0 x 6.0 x 2.7	N/A	-	-
No.5 semi-anechoic chamber	-	6.0 x 6.0 x 3.9	6.0 x 6.0	-	-
No.6 shielded room	-	4.0 x 4.5 x 2.7	4.0 x 4.5	-	-
No.6 measurement room	-	4.75 x 5.4 x 3.0	4.75 x 4.15	-	-
No.7 shielded room	-	4.7 x 7.5 x 2.7	4.7 x 7.5	-	-
No.8 measurement room	-	3.1 x 5.0 x 2.7	3.1 x 5.0	-	-
No.9 measurement room	-	8.8 x 4.6 x 2.8	2.4 x 2.4	-	-
No.11 measurement room	-	6.2 x 4.7 x 3.0	4.8 x 4.6	-	-

* Size of vertical conducting plane (for Conducted Emission test) : 2.0 m x 2.0m for No.1, No.2, No.3, and No.4 semi-anechoic chambers and No.3 and No.4 shielded rooms.

3.6 Test data, Test instruments, and Test set up

Refer to APPENDIX.

SECTION 4: Operation of E.U.T. during testing

4.1 Operating Mode(s)

Mode	Remarks*
Transmitting (Tx)	-
<p>*Power of the EUT was set by the software as follows; Power setting value: A Software: 1SU RF Test FW Ver.1.0 *This setting of software is the worst case. Any conditions under the normal use do not exceed the condition of setting. In addition, end users cannot change the settings of the output power of the product.</p>	

*The details of Operating mode(s)

Test Item	Operating Mode	Tested antenna port	Tested frequency
Conducted Emission	Transmitting (Tx)	1 *1)	915.0 MHz *3)
99 % Occupied Bandwidth 6 dB Bandwidth Spurious Emission (Conducted)	Transmitting (Tx)	1 *1)	902.5 MHz 915.0 MHz 927.5 MHz
Spurious Emission (Radiated)	Transmitting (Tx)	2 *2)	902.5 MHz 915.0 MHz 927.5 MHz
Power Density	Transmitting (Tx)	1 *1)	902.5 MHz 915.0 MHz 927.5 MHz
Maximum Peak Output Power	Transmitting (Tx)	1, 2	902.5 MHz 915.0 MHz 927.5 MHz
<p>*Tests were performed with 100 percent transmission. *1) After the comparison between Antenna 1 and Antenna 2, Conducted Emission and Antenna Terminal Conducted tests were performed with the antenna 1 that had higher power as a representative. *2) After the comparison between Antenna 1 and Antenna 2, Radiated Emission test was performed with the antenna 2 that had higher power as a representative. *3) The mode was tested as a representative, because it had the highest power at antenna terminal test.</p>			

UL Japan, Inc.

Ise EMC Lab.

4383-326 Asama-cho, Ise-shi, Mie-ken 516-0021 JAPAN

Telephone : +81 596 24 8999

Facsimile : +81 596 24 8124

4.2 Configuration and peripherals

For Conducted Emission test

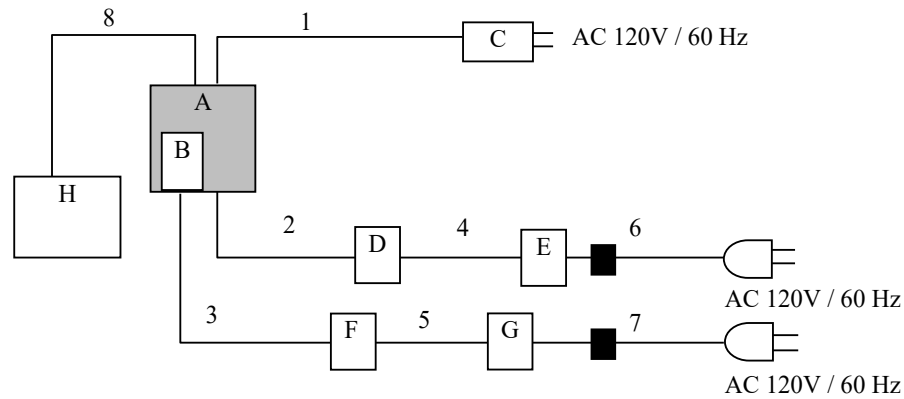

■ : Standard Ferrite Core

* Cabling and setup(s) were taken into consideration and test data was taken under worse case conditions.

Description of EUT and Support equipment

No.	Item	Model number	Serial number	Manufacturer	Remarks
A	Gateway	LBAC0ZZ1SU	R1	Murata Manufacturing Co., Ltd.	EUT
B	Micro SD Card	-	-	-	-
C	AC Adapter	HMD 11PQA	HWHKAAD121094	Huawei Technologies Co Ltd	-
D	Laptop PC	CF-N8HWC DPS	9LKSA04645	Panasonic	-
E	AC Adapter	CF-AA6372B	18054B	Panasonic	-
F	Laptop PC	CF-N8HWC DPS	0CKSA09265	Panasonic	-
G	AC Adapter	CF-AA6372B	6372BM610X10953E	Panasonic	-
H	USB memory	USB4GR	17116DGGNN	SONY	-

List of cables used

No.	Name	Length (m)	Shield		Remarks
			Cable	Connector	
1	USB Cable	2.0	Shielded	Shielded	-
2	LAN Cable	3.0	Unshielded	Unshielded	-
3	LAN Cable	3.0	Unshielded	Unshielded	-
4	DC Cable	1.0	Unshielded	Unshielded	-
5	DC Cable	1.0	Unshielded	Unshielded	-
6	AC Cable	0.8	Unshielded	Unshielded	-
7	AC Cable	0.8	Unshielded	Unshielded	-
8	USB Cable	2.0	Shielded	Shielded	-

UL Japan, Inc.

Ise EMC Lab.

4383-326 Asama-cho, Ise-shi, Mie-ken 516-0021 JAPAN

Telephone : +81 596 24 8999

Facsimile : +81 596 24 8124

For Radiated Emission test and Antenna Terminal Conducted Tests

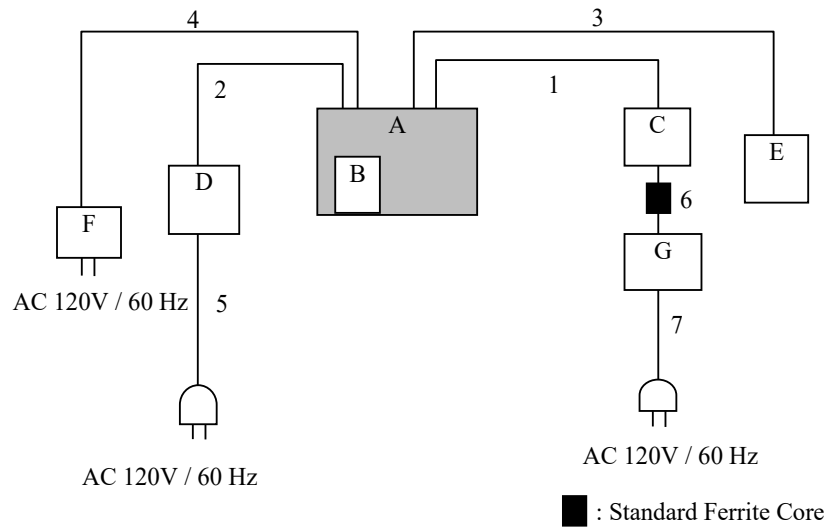

* Cabling and setup(s) were taken into consideration and test data was taken under worse case conditions.

Description of EUT and Support equipment

No.	Item	Model number	Serial number	Manufacturer	Remarks
A	Gateway	LBAC0ZZ1SU	C1 *1) R1 *2)	Murata Manufacturing Co., Ltd.	EUT
B	Micro SD Card	-	-	-	-
C	Laptop PC	CF-N8HWCDPS	OBKSA08729	Panasonic	-
D	LAN Hub	FX-0815	07DK01286C	PLANEX	-
E	USB memory	USM4GR	17116DGGNN	SONY	-
F	AC Adapter	HMD 11PQA	HWHKAAD121094	Huawei Technologies Co Ltd	-
G	AC Adapter	CF-AA6372B M4	6372BM409X18054B	Panasonic	-

*1) Used for Antenna Terminal conducted test

*2) Used for Radiated Emission test

List of cables used

No.	Name	Length (m)	Shield		Remarks
			Cable	Connector	
1	LAN Cable	3.0	Unshielded	Unshielded	-
2	LAN Cable	3.0	Unshielded	Unshielded	-
3	USB Cable	3.0	Shielded	Shielded	-
4	USB Cable	2.0	Shielded	Shielded	-
5	AC Cable	1.7	Unshielded	Unshielded	-
6	DC Cable	1.0	Unshielded	Unshielded	-
7	AC Cable	0.8	Unshielded	Unshielded	-

SECTION 5: Conducted Emission

Test Procedure and conditions

EUT was placed on a urethane platform of nominal size, 1.0 m by 1.5 m, raised 0.8 m above the conducting ground plane.

The rear of tabletop was located 40 cm to the vertical conducting plane. The rear of EUT, including peripherals aligned and flushed with rear of tabletop. All other surfaces of tabletop were at least 80cm from any other grounded conducting surface. EUT was located 80 cm from a Line Impedance Stabilization Network (LISN) / Artificial mains Network (AMN) and excess AC cable was bundled in center.

For the tests on EUT with other peripherals (as a whole system)

I/O cables that were connected to the peripherals were bundled in center. They were folded back and forth forming a bundle 30 cm to 40 cm long and were hanged at a 40 cm height to the ground plane. All unused 50ohm connectors of the LISN (AMN) were resistivity terminated in 50 ohm when not connected to the measuring equipment.

The AC Mains Terminal Continuous disturbance Voltage has been measured with the EUT in a Semi Anechoic Chamber.

The EUT was connected to a LISN (AMN).

An overview sweep with peak detection has been performed.

The test results and limit are rounded off to one decimal place, so some differences might be observed.

Detector	: QP and CISPR AV
Measurement range	: 0.15 MHz - 30 MHz
Test data	: APPENDIX
Test result	: Pass

Figure 1: Test Setup

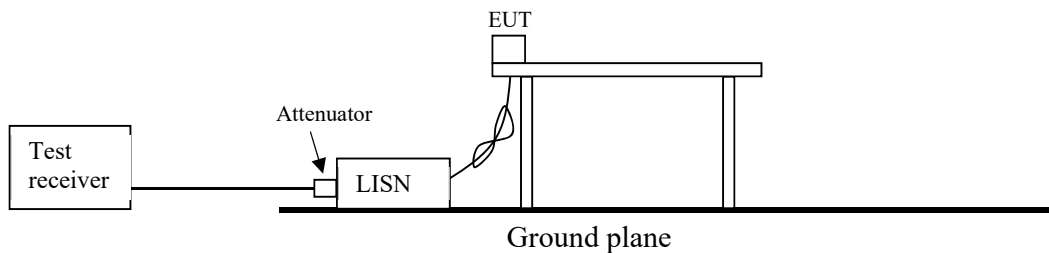

SECTION 6: Radiated Spurious Emission

Test Procedure

It was measured based on "8.5 and 8.6 of KDB 558074 D01 15.247 Meas Guidance v05r02".

[For below 1 GHz]

EUT was placed on a urethane platform of nominal size, 1.0 m by 1.5 m, raised 0.8 m above the conducting ground plane. The Radiated Electric Field Strength has been measured in a Semi Anechoic Chamber with a ground plane.

[For above 1 GHz]

EUT was placed on a urethane platform of nominal size, 0.5 m by 0.5 m, raised 1.5 m above the conducting ground plane.

The Radiated Electric Field Strength has been measured in a Semi Anechoic Chamber with absorbent materials lined on a ground plane.

The height of the measuring antenna varied between 1 and 4 m and EUT was rotated a full revolution in order to obtain the maximum value of the electric field strength.

The measurements were performed for both vertical and horizontal antenna polarization with the Test Receiver, or the Spectrum Analyzer.

The measurements were made with the following detector function of the test receiver and the Spectrum analyzer (in linear mode).

The test was made with the detector (RBW/VBW) in the following table.

When using Spectrum analyzer, the test was made with adjusting span to zero by using peak hold.

Test Antennas are used as below;

Frequency	30 MHz to 200 MHz	200 MHz to 1 GHz	Above 1 GHz
Antenna Type	Biconical	Logperiodic	Horn

In any 100 kHz bandwidth outside the restricted band in which the spread spectrum intentional radiator is operating, the radio frequency power that is produced by the intentional radiator confirmed 20 dB below that in the 100 kHz bandwidth within the band that contains the highest level of the desired power, based on a radiated measurement.

20 dBc was applied to the frequency over the limit of FCC 15.209 / Table 4 of RSS-Gen 8.9(IC) and outside the restricted band of FCC15.205 / Table 6 of RSS-Gen 8.10 (IC).

Frequency	Below 1 GHz	Above 1 GHz		20 dBc
Instrument used	Test Receiver	Spectrum Analyzer		Spectrum Analyzer
Detector	QP	PK	AV *1)	PK
IF Bandwidth	BW 120 kHz	RBW: 1 MHz VBW: 3 MHz	11.12.2.5.1 RBW: 1 MHz VBW: 3 MHz Detector: Power Averaging (RMS) Trace: 100 traces 11.12.2.5.2 The duty cycle was less than 98% for detected noise, a duty factor was added to the 11.12.2.5.1 results.	RBW: 100 kHz VBW: 300 kHz

*1) Average Power Measurement was performed based on ANSI C63.10-2013.

Figure 2: Test Setup

Below 1 GHz

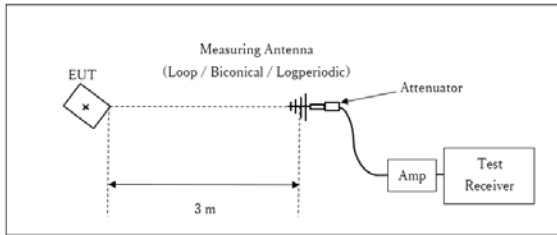

x : Center of turn table

Test Distance: 3 m

1 GHz - 10 GHz

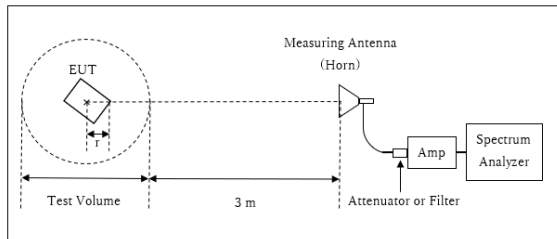

r : Radius of an outer periphery of EUT
 x : Center of turn table

Distance Factor: $20 \times \log(3.9 \text{ m} / 3.0 \text{ m}) = 2.28 \text{ dB}$
 * Test Distance: $(3 + \text{Test Volume} / 2) - r = 3.9 \text{ m}$

Test Volume : 2.0 m
 (Test Volume has been calibrated based on CISPR 16-1-4.)
 $r = 0.1 \text{ m}$

- The carrier level and noise levels were confirmed at each position of X, Y and Z axes of EUT to see the position of maximum noise, and the test was made at the position that has the maximum noise.

The test results and limit are rounded off to one decimal place, so some differences might be observed.

Measurement range : 30 MHz - 10 GHz
Test data : APPENDIX
Test result : Pass

SECTION 7: Antenna Terminal Conducted Tests

Test Procedure

The tests were made with below setting connected to the antenna port.

Test	Span	RBW	VBW	Sweep time	Detector	Trace	Instrument used
6dB Bandwidth	2 MHz	100 kHz	300 kHz	Auto	Peak	Max Hold	Spectrum Analyzer
99% Occupied Bandwidth *1)	Enough width to display emission skirts	1 to 5 % of OBW	Three times of RBW	Auto	Peak	Max Hold	Spectrum Analyzer
Maximum Peak Output Power	-	-	-	Auto	Peak/Average *2)	-	Power Meter (Sensor: 50 MHz BW)
Peak Power Density	1.5 times the 6dB Bandwidth	3 kHz	10 kHz	Auto	Peak	Max Hold	Spectrum Analyzer *3)
Conducted Spurious Emission *4)	9kHz to 150kHz	200 Hz	620 Hz	Auto	Peak	Max Hold	Spectrum Analyzer
	150kHz to 30MHz	9.1 kHz	27 kHz				
*1) Peak hold was applied as Worst-case measurement. *2) Reference data *3) Section 11.10.2 Method PKPSD (peak PSD) of "ANSI C63.10-2013". *4) In the frequency range below 30MHz, RBW was narrowed to separate the noise contents. Then, wide-band noise near the limit was checked separately, however the noise was not detected as shown in the chart.							

The test results and limit are rounded off to two decimals place, so some differences might be observed.
The equipment and cables were not used for factor 0 dB of the data sheets.

Test data : APPENDIX
Test result : Pass

APPENDIX 1: Test data

Conducted Emission

Report No. 12752904H
 Test place Ise EMC Lab. No.4 Semi Anechoic Chamber
 Date April 11, 2019
 Temperature / Humidity 23 deg. C / 30 % RH
 Engineer Tomohisa Nakagawa
 Mode Tx ANT 1 / 915.0MHz

FCC_Part 15 Subpart C (15.207)

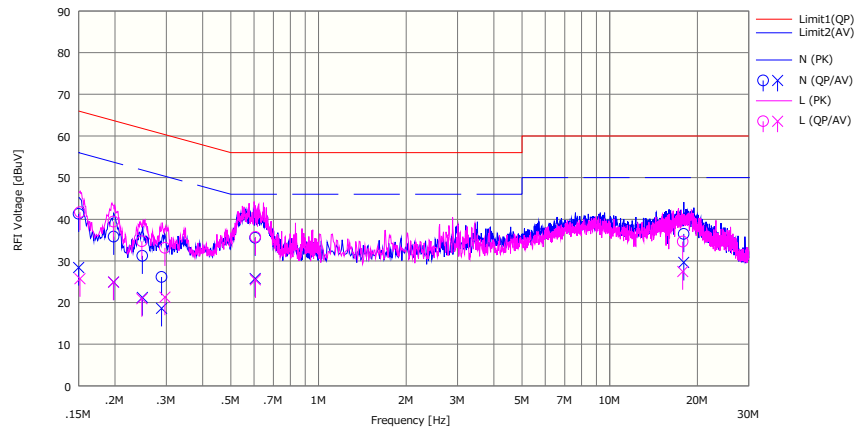

No.	Freq. [MHz]	Reading		USN	LOSS	Results		Limit		Margin		Phase	Comment
		(QP)	(AV)			(QP)	(AV)	(QP)	(AV)	(QP)	(AV)		
		[dBuV]	[dBuV]			[dB]	[dB]	[dBuV]	[dBuV]	[dB]	[dB]		
1	0.15008	27.90	15.00	0.13	13.28	41.31	28.41	66.00	56.00	24.69	27.59	N	
2	0.19785	22.40	11.50	0.13	13.29	35.82	24.92	63.70	53.70	27.88	28.78	N	
3	0.24817	17.80	7.80	0.13	13.29	31.22	21.22	61.80	51.80	30.58	30.58	N	
4	0.28902	12.70	5.20	0.13	13.30	26.13	18.63	60.60	50.60	34.47	31.97	N	
5	0.60588	22.10	12.30	0.14	13.32	35.56	25.76	56.00	46.00	20.44	20.24	N	
6	17.94995	20.60	13.80	1.91	13.95	36.46	29.66	60.00	50.00	23.54	20.34	N	
7	0.15154	28.30	12.30	0.13	13.28	41.71	25.71	65.90	55.90	24.19	30.19	L	
8	0.19764	26.00	11.50	0.13	13.29	39.42	24.92	63.70	53.70	24.28	28.78	L	
9	0.24737	21.30	7.50	0.13	13.29	34.72	20.92	61.80	51.80	27.08	30.88	L	
10	0.29675	19.70	7.90	0.13	13.30	33.13	21.33	60.30	50.30	27.17	28.97	L	
11	0.60702	22.30	12.00	0.14	13.32	35.76	25.46	56.00	46.00	20.24	20.54	L	
12	17.80978	18.80	11.60	1.89	13.95	34.64	27.44	60.00	50.00	25.36	22.56	L	

CHART: WITH FACTOR Peak hold data. CALCULATION : RESULT = READING + LISN + LOSS (CABLE + ATT)
 Except for the above table: adequate margin data below the limits.

Conducted Emission

Report No.	12752904H
Test place	Ise EMC Lab. No.4 Semi Anechoic Chamber
Date	April 11, 2019
Temperature / Humidity	23 deg. C / 30 % RH
Engineer	Tomohisa Nakagawa
Mode	Tx ANT 1

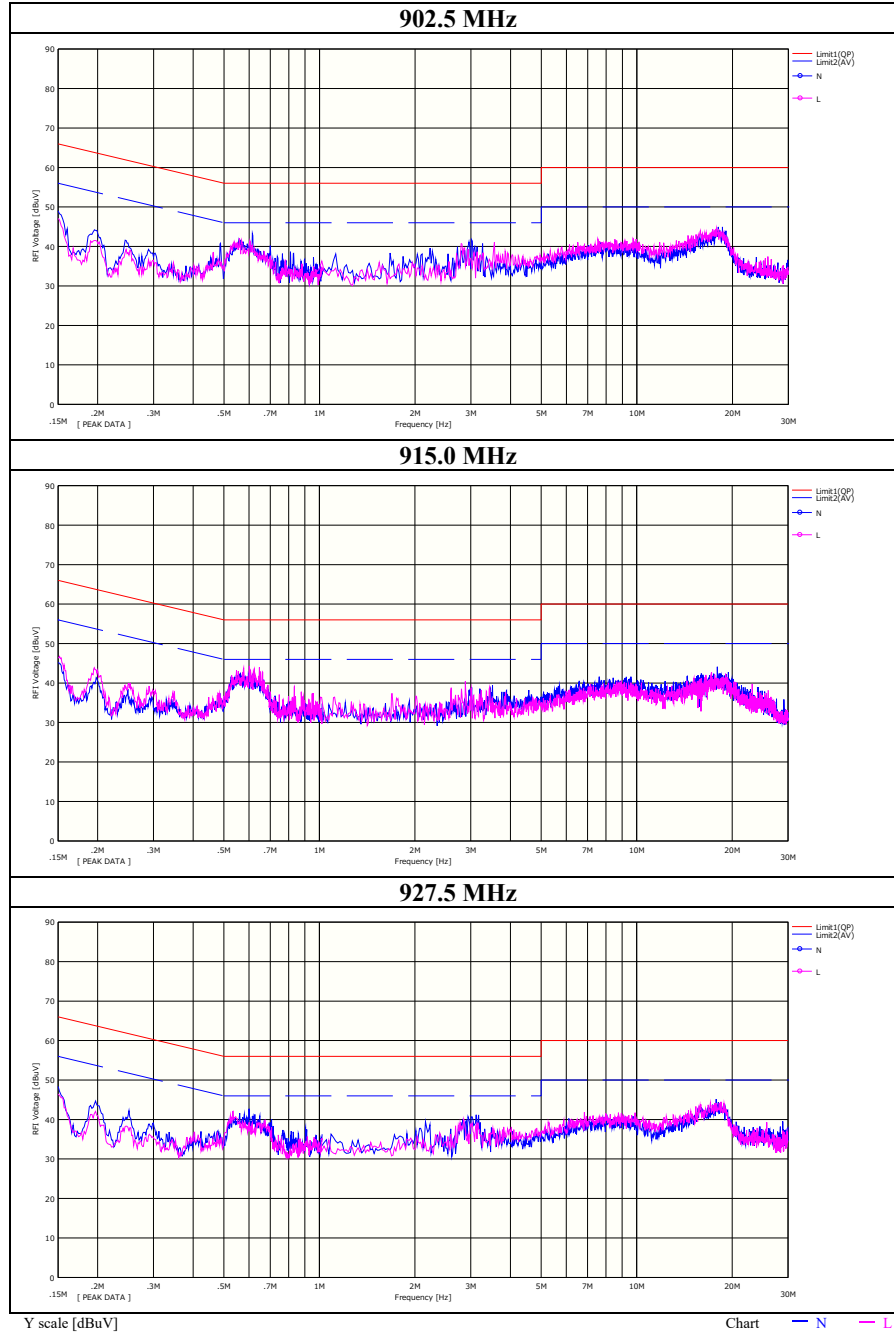

6 dB Bandwidth and 99 % Occupied Bandwidth

Report No. 12752904H
Test place Ise EMC Lab. No.7 Shielded Room
Date April 10, 2019
Temperature / Humidity 23 deg. C / 40 % RH
Engineer Takafumi Noguchi
Mode Tx

Frequency [MHz]	99% Occupied Bandwidth [kHz]	6dB Bandwidth [MHz]	Limit for 6dB Bandwidth [MHz]
902.5	482.8191	0.550	> 0.5000
915.0	480.8668	0.551	> 0.5000
927.5	480.5820	0.551	> 0.5000

99 % Occupied Bandwidth

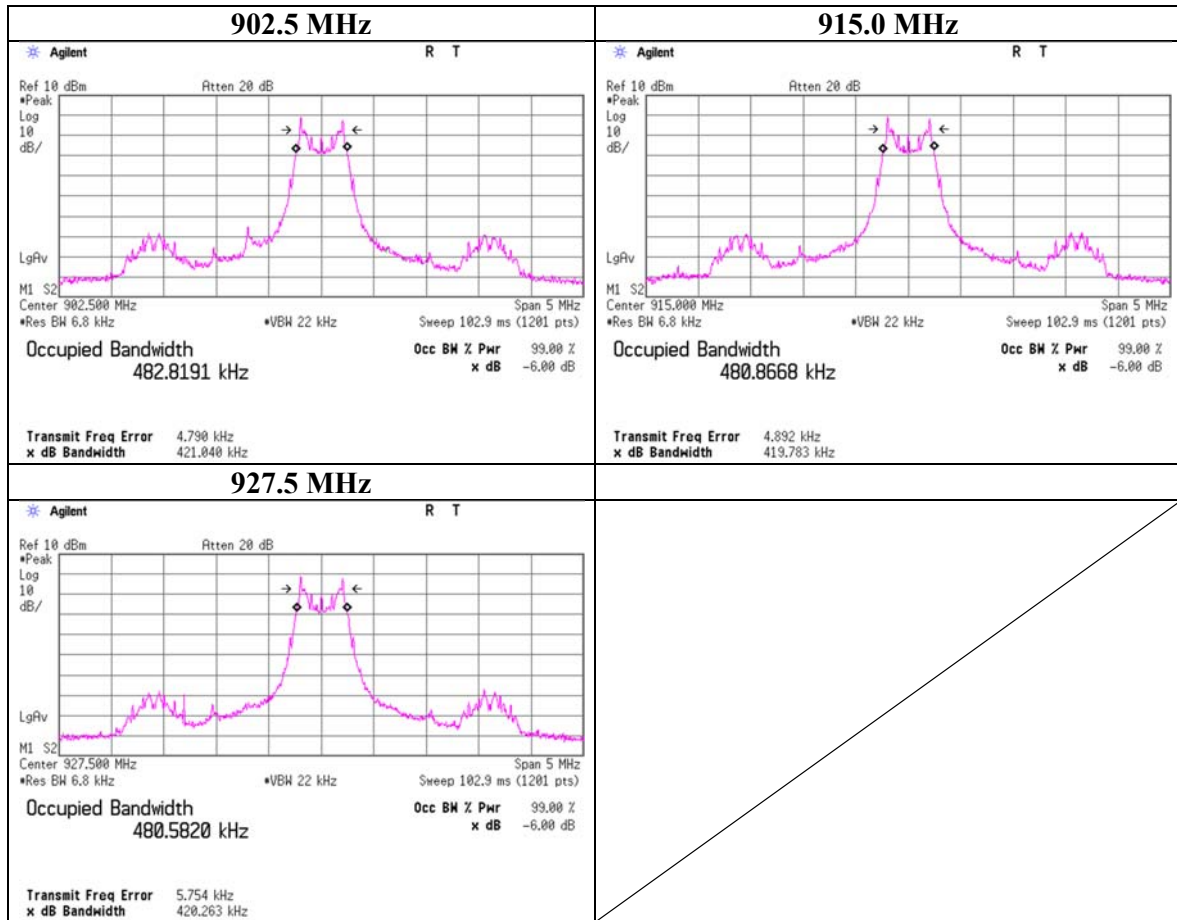

UL Japan, Inc.

Ise EMC Lab.

4383-326 Asama-cho, Ise-shi, Mie-ken 516-0021 JAPAN

Telephone : +81 596 24 8999

Facsimile : +81 596 24 8124

6 dB Bandwidth

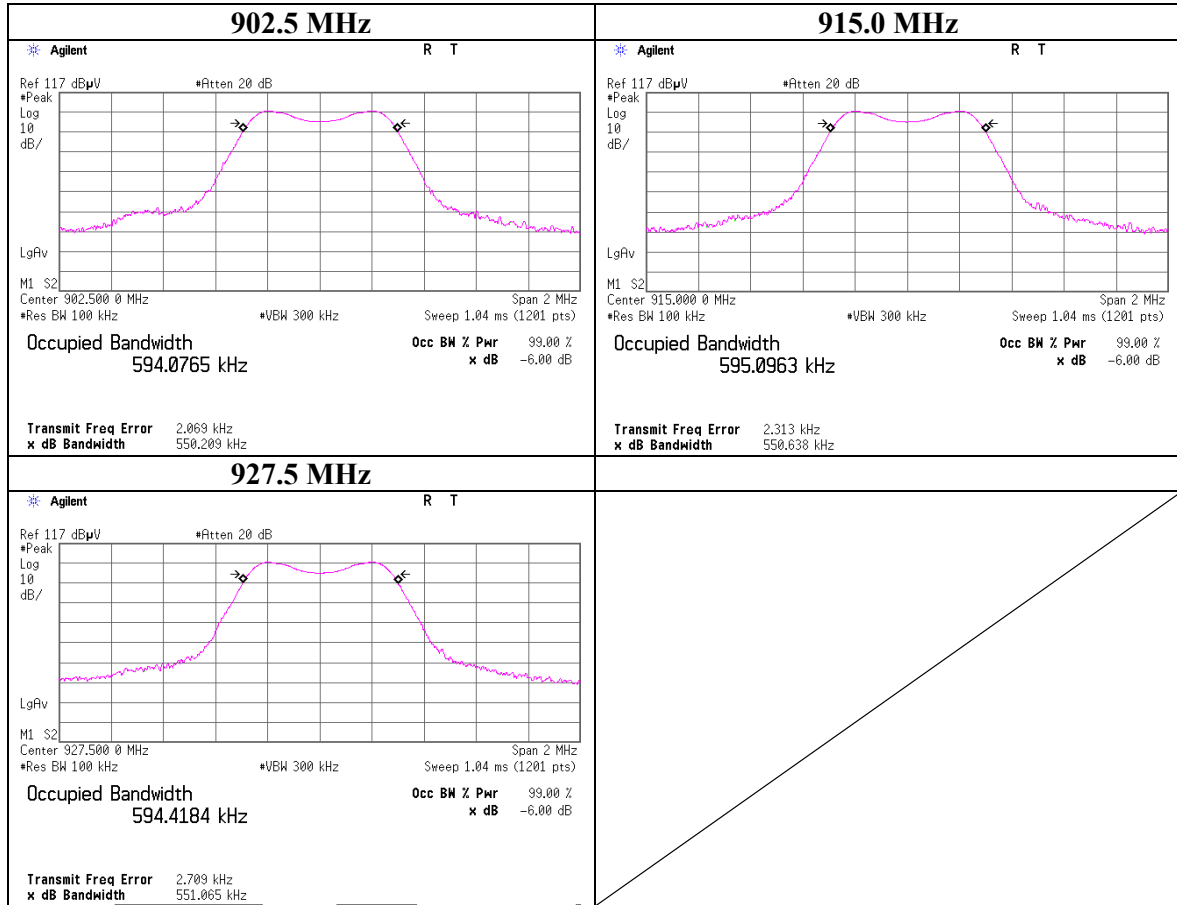

Maximum Peak Output Power

Report No. 12752904H
Test place Ise EMC Lab. No.7 Shielded Room
Date April 10, 2019
Temperature / Humidity 23 deg. C / 40 % RH
Engineer Takafumi Noguchi
Mode Tx

ANT 1				Conducted Power						e.i.r.p. for RSS-247				
Freq. [MHz]	Reading [dBm]	Cable Loss [dB]	Atten. Loss [dB]	Result		Limit		Margin [dB]	Antenna Gain [dBi]	Result		Limit		Margin [dB]
				[dBm]	[mW]	[dBm]	[mW]			[dBm]	[mW]	[dBm]	[mW]	
902.5	0.37	0.18	9.90	10.45	11.09	30.00	1000	19.55	1.70	12.15	16.41	36.02	4000	23.87
915.0	0.40	0.18	9.90	10.48	11.17	30.00	1000	19.52	1.70	12.18	16.52	36.02	4000	23.84
927.5	0.35	0.18	9.90	10.43	11.04	30.00	1000	19.57	1.70	12.13	16.33	36.02	4000	23.89

ANT 2				Conducted Power						e.i.r.p. for RSS-247				
Freq. [MHz]	Reading [dBm]	Cable Loss [dB]	Atten. Loss [dB]	Result		Limit		Margin [dB]	Antenna Gain [dBi]	Result		Limit		Margin [dB]
				[dBm]	[mW]	[dBm]	[mW]			[dBm]	[mW]	[dBm]	[mW]	
902.5	0.23	0.18	9.90	10.31	10.74	30.00	1000	19.69	1.80	12.11	16.26	36.02	4000	23.91
915.0	0.13	0.18	9.90	10.21	10.50	30.00	1000	19.79	1.80	12.01	15.89	36.02	4000	24.01
927.5	0.07	0.18	9.90	10.15	10.35	30.00	1000	19.85	1.80	11.95	15.67	36.02	4000	24.07

Sample Calculation:

Result = Reading + Cable Loss (including the cable(s) customer supplied) + Attenuator Loss

e.i.r.p. Result = Conducted Power Result + Antenna Gain

*The equipment and cables were not used for factor 0 dB of the data sheets.

Average Output Power
(Reference data for RF Exposure)

Report No. 12752904H
Test place Ise EMC Lab. No.7 Shielded Room
Date April 10, 2019
Temperature / Humidity 23 deg. C / 40 % RH
Engineer Takafumi Noguchi
Mode Tx

ANT 1

Freq. [MHz]	Reading [dBm]	Cable Loss [dB]	Atten. Loss [dB]	Result (Time average)	
				[dBm]	[mW]
902.5	-10.87	0.18	9.90	-0.79	0.83
915.0	-10.85	0.18	9.90	-0.77	0.84
927.5	-10.96	0.18	9.90	-0.88	0.82

ANT 2

Freq. [MHz]	Reading [dBm]	Cable Loss [dB]	Atten. Loss [dB]	Result (Time average)	
				[dBm]	[mW]
902.5	-11.04	0.18	9.90	-0.96	0.80
915.0	-11.15	0.18	9.90	-1.07	0.78
927.5	-11.22	0.18	9.90	-1.14	0.77

Sample Calculation:

Result (Time average) = Reading + Cable Loss (including the cable(s) customer supplied) + Attenuator Loss

Burst rate confirmation

Report No. 12752904H
 Test place Ise EMC Lab. No.7 Shielded Room
 Date April 10, 2019
 Temperature / Humidity 23 deg. C / 40 % RH
 Engineer Takafumi Noguchi
 Mode Tx

【ALL tests for except for Average Output Power】

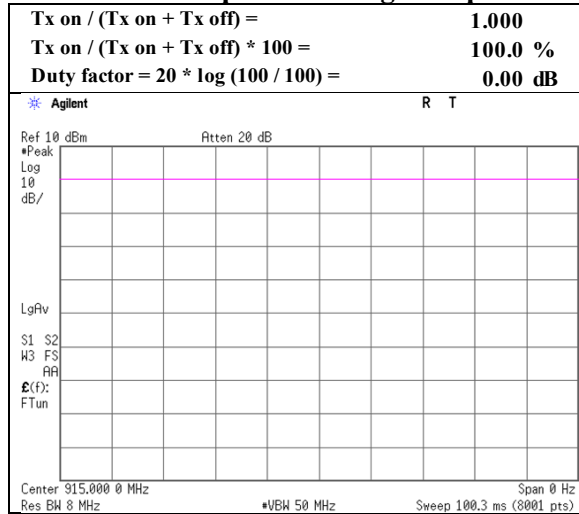

【Average Output Power only *】

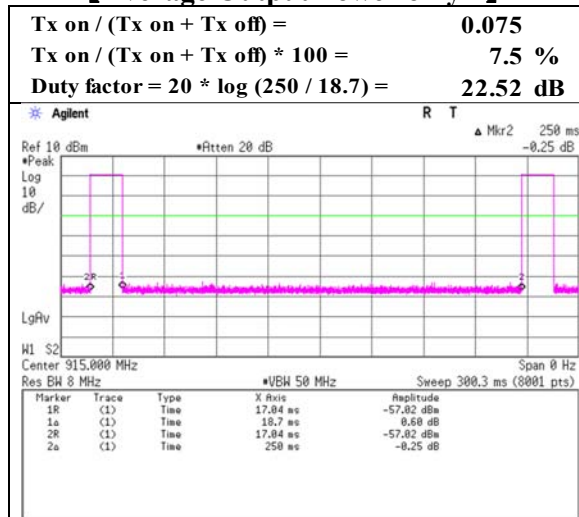

* The Average Output Power test was performed with actual duty cycle transmission.

Radiated Spurious Emission

Report No.	12752904H	
Test place	Ise EMC Lab.	
Semi Anechoic Chamber	No.4	No.4
Date	March 28, 2019	March 29, 2019
Temperature / Humidity	23 deg. C / 32 % RH	24 deg. C / 36 % RH
Engineer	Junki Nagatomi (Below 1 GHz)	Takumi Shimada (Above 1 GHz)
Mode	Tx 902.5MHz	

Polarity	Frequency [MHz]	Detector	Reading [dBuV]	Ant.Fac. [dB/m]	Loss [dB]	Gain [dB]	Duty Factor [dB]	Result [dBuV/m]	Limit [dBuV/m]	Margin [dB]	Remark
Hori.	96.318	QP	39.4	9.5	8.2	32.1	-	24.9	43.5	18.6	
Hori.	250.030	QP	53.6	11.7	9.6	32.0	-	43.0	46.0	3.1	
Hori.	349.983	QP	41.4	15.0	10.3	31.9	-	34.8	46.0	11.3	
Hori.	374.999	QP	45.3	15.1	10.4	31.9	-	38.9	46.0	7.1	
Hori.	499.996	QP	41.1	17.7	11.3	32.0	-	38.1	46.0	7.9	
Hori.	625.029	QP	35.2	19.6	11.9	32.1	-	34.6	46.0	11.4	
Hori.	2707.500	PK	51.4	28.6	5.8	31.2	-	54.5	73.9	19.4	
Hori.	3610.000	PK	42.2	29.4	6.1	30.9	-	46.9	73.9	27.0	Floor noise
Hori.	4512.500	PK	46.4	30.7	6.5	30.7	-	52.9	73.9	21.0	
Hori.	5415.000	PK	42.7	31.7	6.9	30.8	-	50.5	73.9	23.4	Floor noise
Hori.	2707.500	AV	40.7	28.6	5.8	31.2	-	43.8	53.9	10.1	
Hori.	3610.000	AV	28.7	29.4	6.1	30.9	-	33.4	53.9	20.5	Floor noise
Hori.	4512.500	AV	33.7	30.7	6.5	30.7	-	40.2	53.9	13.7	
Hori.	5415.000	AV	28.1	31.7	6.9	30.8	-	36.0	53.9	17.9	Floor noise
Vert.	98.444	QP	43.7	10.0	8.2	32.1	-	29.7	43.5	13.8	
Vert.	250.012	QP	51.3	11.7	9.6	32.0	-	40.7	46.0	5.4	
Vert.	349.998	QP	35.9	15.0	10.3	31.9	-	29.3	46.0	16.8	
Vert.	375.001	QP	40.1	15.1	10.4	31.9	-	33.7	46.0	12.3	
Vert.	500.062	QP	39.3	17.7	11.3	32.0	-	36.3	46.0	9.7	
Vert.	625.001	QP	41.7	19.6	11.9	32.1	-	41.1	46.0	4.9	
Vert.	2707.500	PK	47.9	28.6	5.8	31.2	-	51.1	73.9	22.8	
Vert.	3610.000	PK	42.7	29.4	6.1	30.9	-	47.4	73.9	26.5	Floor noise
Vert.	4512.500	PK	44.4	30.7	6.5	30.7	-	50.9	73.9	23.0	
Vert.	5415.000	PK	42.8	31.7	6.9	30.8	-	50.6	73.9	23.3	Floor noise
Vert.	2707.500	AV	37.1	28.6	5.8	31.2	-	40.2	53.9	13.7	
Vert.	3610.000	AV	28.7	29.4	6.1	30.9	-	33.4	53.9	20.5	Floor noise
Vert.	4512.500	AV	31.9	30.7	6.5	30.7	-	38.4	53.9	15.5	
Vert.	5415.000	AV	28.1	31.7	6.9	30.8	-	36.0	53.9	17.9	Floor noise

Result = Reading + Ant Factor + Loss (Cable+Attenuator+Filter+Distance factor(above 1 GHz)) - Gain(Amplifier)

*Other frequency noises omitted in this report were not seen or had enough margin (more than 20 dB).

Distance factor: 1 GHz - 10 GHz 20log(3.9 m / 3.0 m) = 2.28 dB

20dBc Data Sheet

Polarity	Frequency [MHz]	Detector	Reading [dBuV]	Ant Factor [dB/m]	Loss [dB]	Gain [dB]	Result [dBuV/m]	Limit [dBuV/m]	Margin [dB]	Remark
Hori.	902.500	PK	106.1	21.9	13.3	31.1	110.2	-	-	Carrier
Hori.	900.000	PK	54.1	22.0	13.2	31.1	58.2	90.2	32.0	
Hori.	902.000	PK	60.4	22.0	13.3	31.1	64.5	90.2	25.8	
Hori.	1805.000	PK	38.1	25.6	5.5	32.0	33.4	90.2	56.8	
Vert.	902.500	PK	106.6	21.9	13.3	31.1	110.7	-	-	Carrier
Vert.	900.000	PK	55.6	22.0	13.2	31.1	59.7	90.7	31.0	
Vert.	902.000	PK	60.1	22.0	13.3	31.1	64.2	90.7	26.5	
Vert.	1805.000	PK	35.0	25.6	5.5	32.0	34.0	90.7	56.7	

Result = Reading + Ant Factor + Loss (Cable+Attenuator+Filter+Distance factor(above 1 GHz)) - Gain(Amplifier)

Distance factor: 1 GHz - 10 GHz 20log(3.9 m / 3.0 m) = 2.28 dB

Radiated Spurious Emission
(Reference Plot for band-edge)

Report No.	12752904H
Test place	Ise EMC Lab.
Semi Anechoic Chamber	No.4
Date	March 28, 2019
Temperature / Humidity	23 deg. C / 32 % RH
Engineer	Junki Nagatomi (Below 1 GHz)
Mode	Tx 902.5MHz

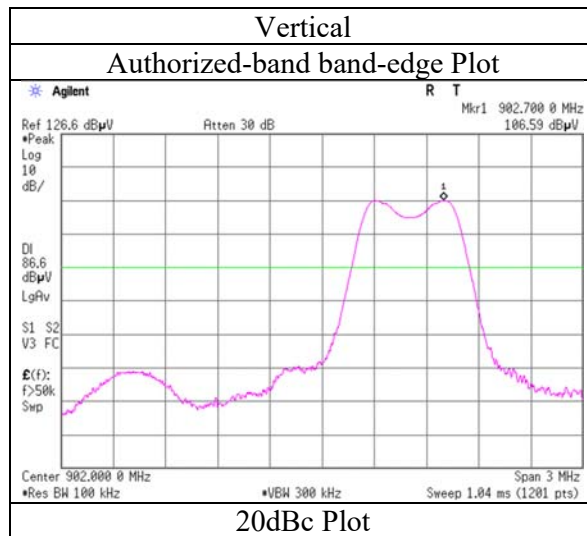
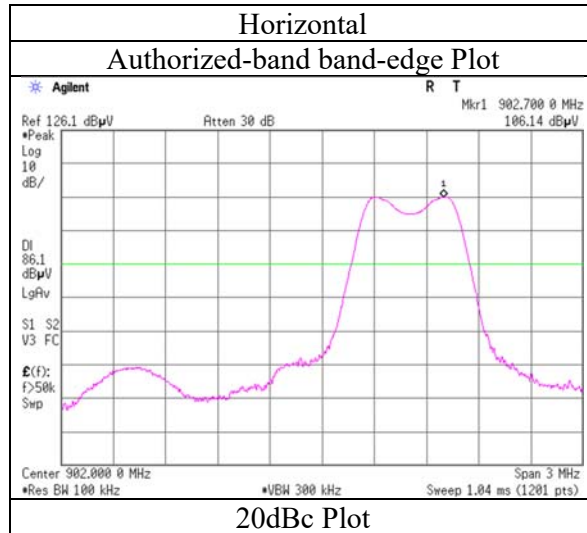

* The measurement was conducted for a sufficiently long enough time to detect any possible spurious emissions.
 Final result of restricted band edge was shown in tabular data.

Radiated Spurious Emission

Report No.	12752904H	
Test place	Ise EMC Lab.	
Semi Anechoic Chamber	No.4	No.4
Date	March 28, 2019	March 29, 2019
Temperature / Humidity	23 deg. C / 32 % RH	24 deg. C / 36 % RH
Engineer	Junki Nagatomi (Below 1 GHz)	Takumi Shimada (Above 1 GHz)
Mode	Tx 915.0MHz	

Polarity	Frequency [MHz]	Detector	Reading [dBuV]	Ant.Fac. [dB/m]	Loss [dB]	Gain [dB]	Duty Factor [dB]	Result [dBuV/m]	Limit [dBuV/m]	Margin [dB]	Remark
Hori.	125.002	QP	39.1	13.2	8.5	32.1	-	28.7	43.5	14.8	
Hori.	131.622	QP	39.7	14.0	8.5	32.1	-	30.1	43.5	13.4	
Hori.	250.029	QP	55.6	0.0	9.6	32.0	-	33.2	46.0	12.8	
Hori.	375.012	QP	42.0	15.1	10.4	31.9	-	35.6	46.0	10.4	
Hori.	500.008	QP	38.6	17.7	11.3	32.0	-	35.6	46.0	10.4	
Hori.	625.052	QP	34.8	19.6	11.9	32.1	-	34.2	46.0	11.8	
Hori.	2745.000	PK	51.7	28.7	5.8	31.2	-	55.0	73.9	18.9	
Hori.	3660.000	PK	42.5	29.2	6.1	30.8	-	47.0	73.9	26.9	Floor noise
Hori.	4575.000	PK	45.1	30.7	6.5	30.7	-	51.7	73.9	22.2	
Hori.	5490.000	PK	41.4	31.9	7.0	30.8	-	49.4	73.9	24.5	Floor noise
Hori.	2745.000	AV	45.9	28.7	5.8	31.2	-	49.2	53.9	4.7	
Hori.	3660.000	AV	28.8	29.2	6.1	30.8	-	33.4	53.9	20.6	Floor noise
Hori.	4575.000	AV	32.7	30.7	6.5	30.7	-	39.2	53.9	14.7	
Hori.	5490.000	AV	28.0	31.9	7.0	30.8	-	36.0	53.9	17.9	Floor noise
Vert.	59.826	QP	44.6	7.7	7.7	32.2	-	27.9	40.0	12.1	
Vert.	125.002	QP	38.6	13.2	8.5	32.1	-	28.2	43.5	15.3	
Vert.	131.622	QP	36.4	14.0	8.5	32.1	-	26.8	43.5	16.7	
Vert.	250.029	QP	50.6	11.7	9.6	32.0	-	40.0	46.0	6.1	
Vert.	375.012	QP	38.6	15.1	10.4	31.9	-	32.2	46.0	13.8	
Vert.	626.221	QP	37.9	19.6	11.9	32.1	-	37.3	46.0	8.7	
Vert.	2745.000	PK	50.0	28.7	5.8	31.2	-	53.3	73.9	20.6	
Vert.	3660.000	PK	43.0	29.2	6.1	30.8	-	47.5	73.9	26.4	Floor noise
Vert.	4575.000	PK	43.7	30.7	6.5	30.7	-	50.3	73.9	23.6	
Vert.	5490.000	PK	42.0	31.9	7.0	30.8	-	50.1	73.9	23.8	Floor noise
Vert.	2745.000	AV	39.1	28.7	5.8	31.2	-	42.4	53.9	11.5	
Vert.	3660.000	AV	28.8	29.2	6.1	30.8	-	33.3	53.9	20.6	Floor noise
Vert.	4575.000	AV	31.2	30.7	6.5	30.7	-	37.8	53.9	16.1	
Vert.	5490.000	AV	28.8	31.9	7.0	30.8	-	36.9	53.9	17.0	Floor noise

Result = Reading + Ant Factor + Loss (Cable+Attenuator+Filter+Distance factor(above 1 GHz)) - Gain(Amplifier)

*Other frequency noises omitted in this report were not seen or had enough margin (more than 20 dB).

Distance factor: 1 GHz - 10 GHz 20log (3.9 m / 3.0 m) = 2.28 dB

20dBc Data Sheet

Polarity	Frequency [MHz]	Detector	Reading [dBuV]	Ant Factor [dB/m]	Loss [dB]	Gain [dB]	Result [dBuV/m]	Limit [dBuV/m]	Margin [dB]	Remark
Hori.	915.000	PK	104.5	21.9	13.3	31.0	108.6	-	-	Carrier
Hori.	1830.000	PK	34.2	25.7	5.5	32.0	33.4	88.6	55.2	
Vert.	915.000	PK	106.8	21.9	13.3	31.0	111.0	-	-	Carrier
Vert.	1830.000	PK	34.7	25.7	5.5	32.0	34.0	91.0	57.0	

Result = Reading + Ant Factor + Loss (Cable+Attenuator+Filter+Distance factor(above 1 GHz)) - Gain(Amplifier)

Distance factor: 1 GHz - 10 GHz 20log (3.9 m / 3.0 m) = 2.28 dB

Radiated Spurious Emission

Report No.	12752904H	
Test place	Ise EMC Lab.	
Semi Anechoic Chamber	No.4	No.4
Date	March 28, 2019	March 29, 2019
Temperature / Humidity	23 deg. C / 32 % RH	24 deg. C / 36 % RH
Engineer	Junki Nagatomi (Below 1 GHz)	Takumi Shimada (Above 1 GHz)
Mode	Tx 927.5MHz	

Polarity	Frequency [MHz]	Detector	Reading [dBuV]	Ant.Fac. [dB/m]	Loss [dB]	Gain [dB]	Duty Factor [dB]	Result [dBuV/m]	Limit [dBuV/m]	Margin [dB]	Remark
Hori.	125.006	QP	39.5	13.2	8.5	32.1	-	29.1	43.5	14.4	
Hori.	250.022	QP	56.1	11.7	9.6	32.0	-	45.5	46.0	0.5	
Hori.	333.316	QP	38.0	14.7	10.2	31.9	-	30.9	46.0	15.1	
Hori.	375.001	QP	41.5	15.1	10.4	31.9	-	35.1	46.0	10.9	
Hori.	500.012	QP	38.4	17.7	11.3	32.0	-	35.4	46.0	10.6	
Hori.	625.060	QP	35.6	19.6	11.9	32.1	-	35.0	46.0	11.0	
Hori.	2782.500	PK	52.9	28.4	5.8	31.2	-	55.9	73.9	18.0	
Hori.	3710.000	PK	42.1	29.1	6.2	30.8	-	46.6	73.9	27.3	Floor noise
Hori.	4637.500	PK	44.2	30.8	6.6	30.7	-	50.9	73.9	23.0	
Hori.	5565.000	PK	42.7	32.0	7.0	30.8	-	51.0	73.9	23.0	Floor noise
Hori.	2782.500	AV	42.9	28.4	5.8	31.2	-	45.9	53.9	8.0	
Hori.	3710.000	AV	28.8	29.1	6.2	30.8	-	33.3	53.9	20.6	Floor noise
Hori.	4637.500	AV	31.2	30.8	6.6	30.7	-	37.9	53.9	16.0	
Hori.	5565.000	AV	28.2	32.0	7.0	30.8	-	36.4	53.9	17.5	Floor noise
Vert.	125.003	QP	44.4	13.2	8.5	32.1	-	34.0	43.5	9.5	
Vert.	250.016	QP	50.9	11.7	9.6	32.0	-	40.3	46.0	5.8	
Vert.	308.200	QP	34.5	13.8	10.0	31.9	-	26.4	46.0	19.6	
Vert.	375.028	QP	38.6	15.1	10.4	31.9	-	32.2	46.0	13.8	
Vert.	500.045	QP	38.7	17.7	11.3	32.0	-	35.7	46.0	10.3	
Vert.	625.084	QP	39.1	19.6	11.9	32.1	-	38.5	46.0	7.5	
Vert.	2782.500	PK	49.8	28.4	5.8	31.2	-	52.8	73.9	21.1	
Vert.	3710.000	PK	42.2	29.1	6.2	30.8	-	46.7	73.9	27.2	Floor noise
Vert.	4637.500	PK	44.7	30.8	6.6	30.7	-	51.4	73.9	22.5	
Vert.	5565.000	PK	42.7	32.0	7.0	30.8	-	50.9	73.9	23.0	Floor noise
Vert.	2782.500	AV	39.3	28.4	5.8	31.2	-	42.3	53.9	11.6	
Vert.	3710.000	AV	28.7	29.1	6.2	30.8	-	33.2	53.9	20.7	Floor noise
Vert.	4637.500	AV	31.4	30.8	6.6	30.7	-	38.1	53.9	15.8	
Vert.	5565.000	AV	28.1	32.0	7.0	30.8	-	36.4	53.9	17.5	Floor noise

Result = Reading + Ant Factor + Loss (Cable+Attenuator+Filter+Distance factor(above 1 GHz)) - Gain(Amplifier)
*Other frequency noises omitted in this report were not seen or had enough margin (more than 20 dB).

Distance factor: 1 GHz - 10 GHz $20\log(3.9\text{ m} / 3.0\text{ m}) = 2.28\text{ dB}$

20dBc Data Sheet

Polarity	Frequency [MHz]	Detector	Reading [dBuV]	Ant Factor [dB/m]	Loss [dB]	Gain [dB]	Result [dBuV/m]	Limit [dBuV/m]	Margin [dB]	Remark
Hori.	927.500	PK	105.4	21.9	13.4	31.0	109.7	-	-	Carrier
Hori.	928.000	PK	60.9	21.9	13.4	31.0	65.1	89.7	24.6	
Hori.	929.100	PK	53.9	21.9	13.4	31.0	58.2	89.7	31.6	
Hori.	1855.000	PK	33.6	25.8	5.5	31.9	33.0	89.7	56.8	
Vert.	927.500	PK	105.5	21.9	13.4	31.0	109.8	-	-	Carrier
Vert.	928.000	PK	60.2	21.9	13.4	31.0	64.5	89.8	25.3	
Vert.	929.100	PK	54.0	21.9	13.4	31.0	58.3	89.8	31.5	
Vert.	1855.000	PK	32.8	25.8	5.5	31.9	32.2	89.8	57.6	

Result = Reading + Ant Factor + Loss (Cable+Attenuator+Filter+Distance factor(above 1 GHz)) - Gain(Amplifier)

Distance factor: 1 GHz - 10 GHz $20\log(3.9\text{ m} / 3.0\text{ m}) = 2.28\text{ dB}$

Radiated Spurious Emission
(Reference Plot for band-edge)

Report No.	12752904H
Test place	Ise EMC Lab.
Semi Anechoic Chamber	No.4
Date	March 28, 2019
Temperature / Humidity	23 deg. C / 32 % RH
Engineer	Junki Nagatomi (Below 1 GHz)
Mode	Tx 927.5MHz

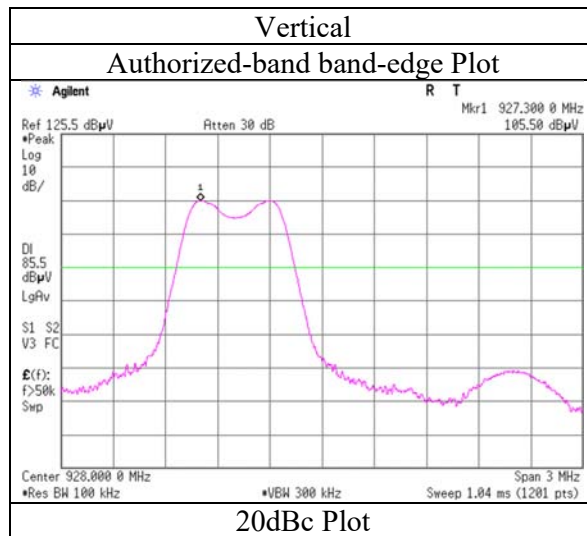
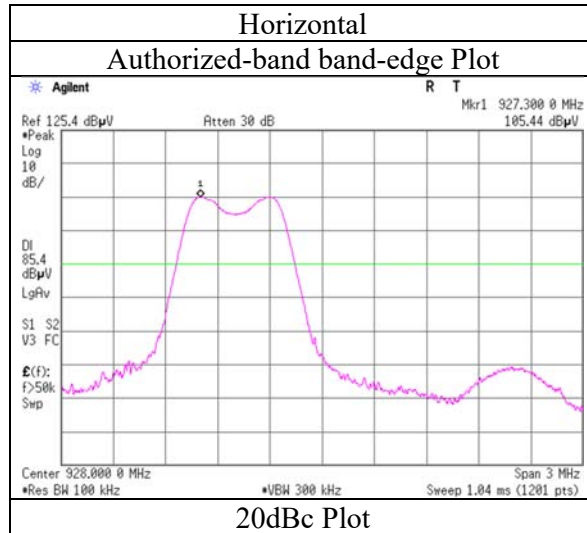

* The measurement was conducted for a sufficiently long enough time to detect any possible spurious emissions.
 Final result of restricted band edge was shown in tabular data.

Radiated Spurious Emission (Plot data, Worst case)

Report No.	12752904H	
Test place	Ise EMC Lab.	
Semi Anechoic Chamber	No.4	No.4
Date	March 28, 2019	March 29, 2019
Temperature / Humidity	23 deg. C / 32 % RH	24 deg. C / 36 % RH
Engineer	Junki Nagatomi (Below 1 GHz)	Takumi Shimada (Above 1 GHz)
Mode	Tx 915.0MHz	

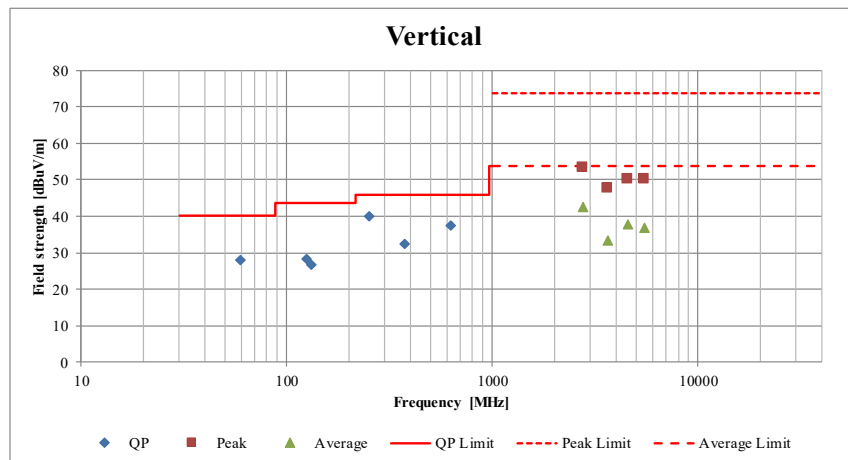
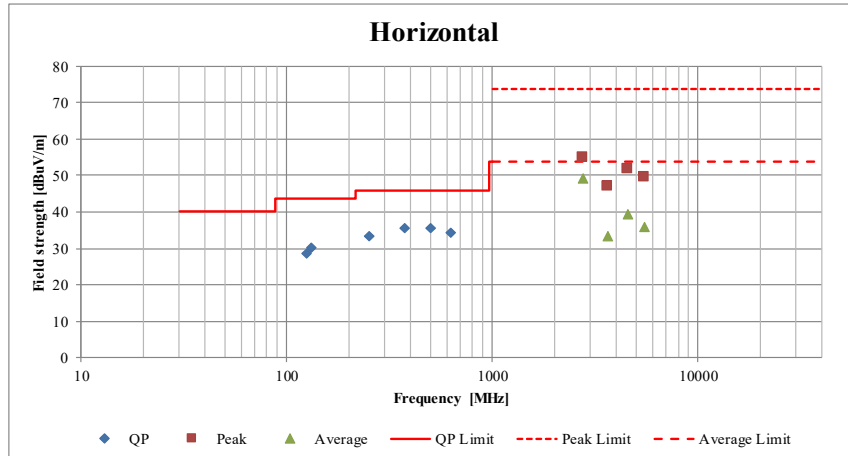

*These plots data contains sufficient number to show the trend of characteristic features for EUT.

Conducted Spurious Emission

Report No. 12752904H
 Test place Ise EMC Lab. No.7 Shielded Room
 Date April 10, 2019
 Temperature / Humidity 23 deg. C / 40 % RH
 Engineer Takafumi Noguchi
 Mode Tx 902.5MHz

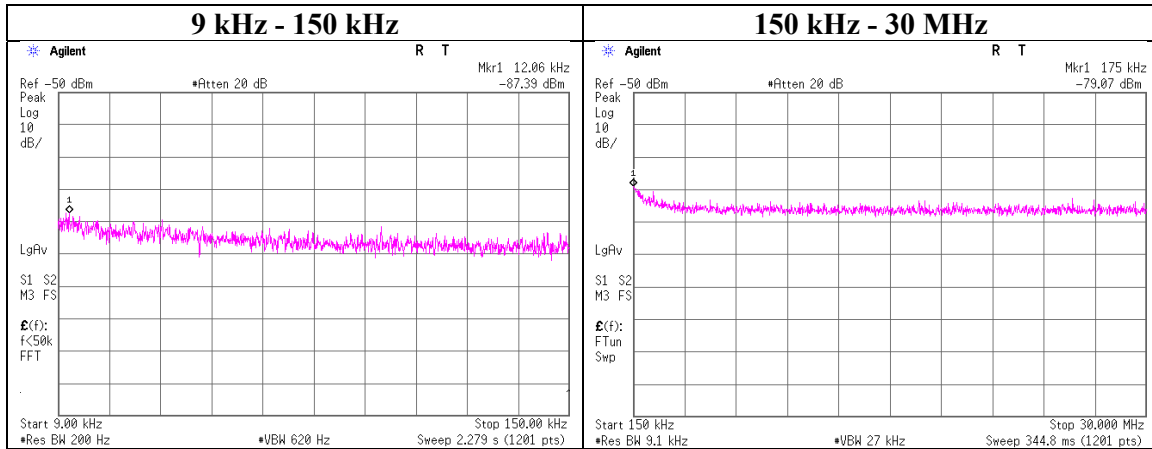

Frequency [kHz]	Reading [dBm]	Cable Loss [dB]	Attenuator Loss [dB]	Antenna Gain* [dBi]	N (Number of Output)	EIRP [dBm]	Distance [m]	Ground bounce [dB]	E (field strength) [dBuV/m]	Limit [dBuV/m]	Margin [dB]	Remark
12.06	-87.4	0.00	9.8	2.0	1	-75.6	300	6.0	-14.3	45.9	60.2	
175.00	-79.1	0.00	9.8	2.0	1	-67.3	300	6.0	-6.0	22.7	28.7	

$E \text{ [dBuV/m]} = \text{EIRP [dBm]} - 20 \log(\text{Distance [m]}) + \text{Ground bounce [dB]} + 104.8 \text{ [dBuV/m]}$

$\text{EIRP [dBm]} = \text{Reading [dBm]} + \text{Cable loss [dB]} + \text{Attenuator Loss [dB]} + \text{Antenna gain [dBi]} + 10 * \log(N)$

N: Number of output

*2.0 dBi was applied to the test result based on ANSI C63.10 since antenna gain was less than 2.0 dBi.

UL Japan, Inc.

Ise EMC Lab.

4383-326 Asama-cho, Ise-shi, Mie-ken 516-0021 JAPAN

Telephone : +81 596 24 8999

Facsimile : +81 596 24 8124

Conducted Spurious Emission

Report No. 12752904H
 Test place Ise EMC Lab. No.7 Shielded Room
 Date April 10, 2019
 Temperature / Humidity 23 deg. C / 40 % RH
 Engineer Takafumi Noguchi
 Mode Tx 915MHz

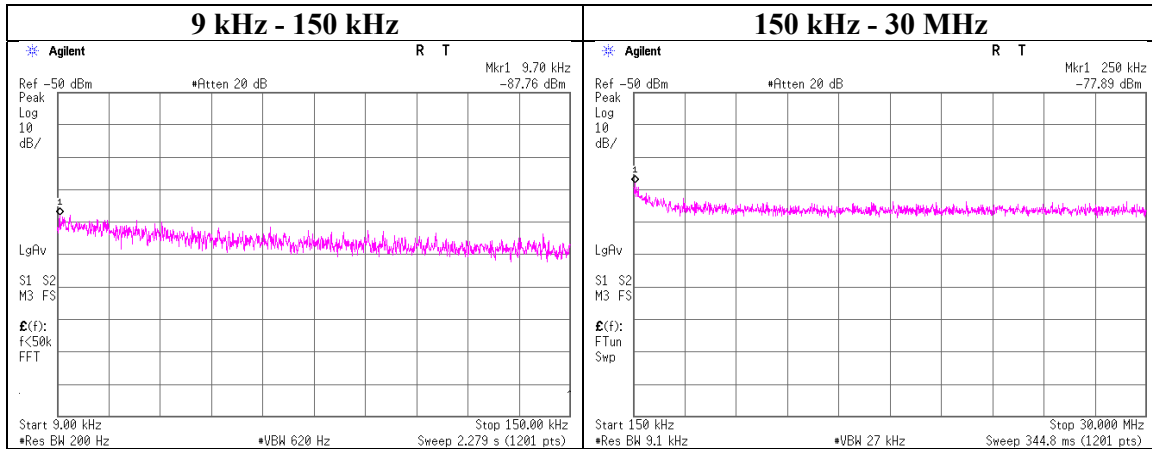

Frequency [kHz]	Reading [dBm]	Cable Loss [dB]	Attenuator Loss [dB]	Antenna Gain* [dBi]	N (Number of Output)	EIRP [dBm]	Distance [m]	Ground bounce [dB]	E (field strength) [dBuV/m]	Limit [dBuV/m]	Margin [dB]	Remark
9.70	-87.8	0.00	9.8	2.0	1	-75.9	300	6.0	-14.7	47.8	62.5	
250.00	-77.9	0.00	9.8	2.0	1	-66.1	300	6.0	-4.8	19.6	24.4	

$E \text{ [dBuV/m]} = \text{EIRP [dBm]} - 20 \log(\text{Distance [m]}) + \text{Ground bounce [dB]} + 104.8 \text{ [dBuV/m]}$

$\text{EIRP [dBm]} = \text{Reading [dBm]} + \text{Cable loss [dB]} + \text{Attenuator Loss [dB]} + \text{Antenna gain [dBi]} + 10 * \log(N)$

N: Number of output

*2.0 dBi was applied to the test result based on ANSI C63.10 since antenna gain was less than 2.0 dBi.

UL Japan, Inc.

Ise EMC Lab.

4383-326 Asama-cho, Ise-shi, Mie-ken 516-0021 JAPAN

Telephone : +81 596 24 8999

Facsimile : +81 596 24 8124

Conducted Spurious Emission

Report No.	12752904H
Test place	Ise EMC Lab. No.7 Shielded Room
Date	April 10, 2019
Temperature / Humidity	23 deg. C / 40 % RH
Engineer	Takafumi Noguchi
Mode	Tx 927.5MHz

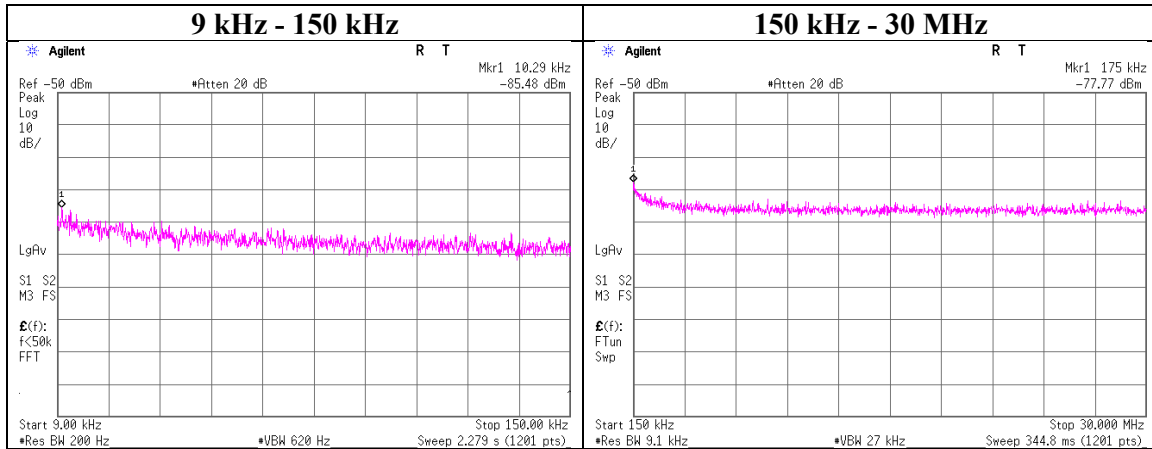

Frequency [kHz]	Reading [dBm]	Cable Loss [dB]	Attenuator Loss [dB]	Antenna Gain* [dBi]	N (Number of Output)	EIRP [dBm]	Distance [m]	Ground bounce [dB]	E (field strength) [dBuV/m]	Limit [dBuV/m]	Margin [dB]	Remark
10.29	-85.5	0.00	9.8	2.0	1	-73.6	300	6.0	-12.4	47.3	59.7	
175.00	-77.8	0.00	9.8	2.0	1	-66.0	300	6.0	-4.7	22.7	27.4	

$E \text{ [dBuV/m]} = \text{EIRP [dBm]} - 20 \log(\text{Distance [m]}) + \text{Ground bounce [dB]} + 104.8 \text{ [dBuV/m]}$

$\text{EIRP [dBm]} = \text{Reading [dBm]} + \text{Cable loss [dB]} + \text{Attenuator Loss [dB]} + \text{Antenna gain [dBi]} + 10 * \log(N)$

N: Number of output

*2.0 dBi was applied to the test result based on ANSI C63.10 since antenna gain was less than 2.0 dBi.

UL Japan, Inc.

Ise EMC Lab.

4383-326 Asama-cho, Ise-shi, Mie-ken 516-0021 JAPAN

Telephone : +81 596 24 8999

Facsimile : +81 596 24 8124

Power Density

Report No. 12752904H
Test place Ise EMC Lab. No.7 Shielded Room
Date April 10, 2019
Temperature / Humidity 23 deg. C / 40 % RH
Engineer Takafumi Noguchi
Mode Tx

ANT 1

Freq. [MHz]	Reading [dBm]	Cable Loss [dB]	Atten. Loss [dB]	Result [dBm]	Limit [dBm]	Margin [dB]
902.5	-3.76	0.18	9.90	6.32	8.00	1.68
915.0	-3.06	0.18	9.90	7.02	8.00	0.98
927.5	-3.00	0.18	9.90	7.08	8.00	0.92

Sample Calculation:

Result = Reading + Cable Loss (including the cable(s) customer supplied) + Attenuator Loss

*The equipment and cables were not used for factor 0 dB of the data sheets.

Power Density

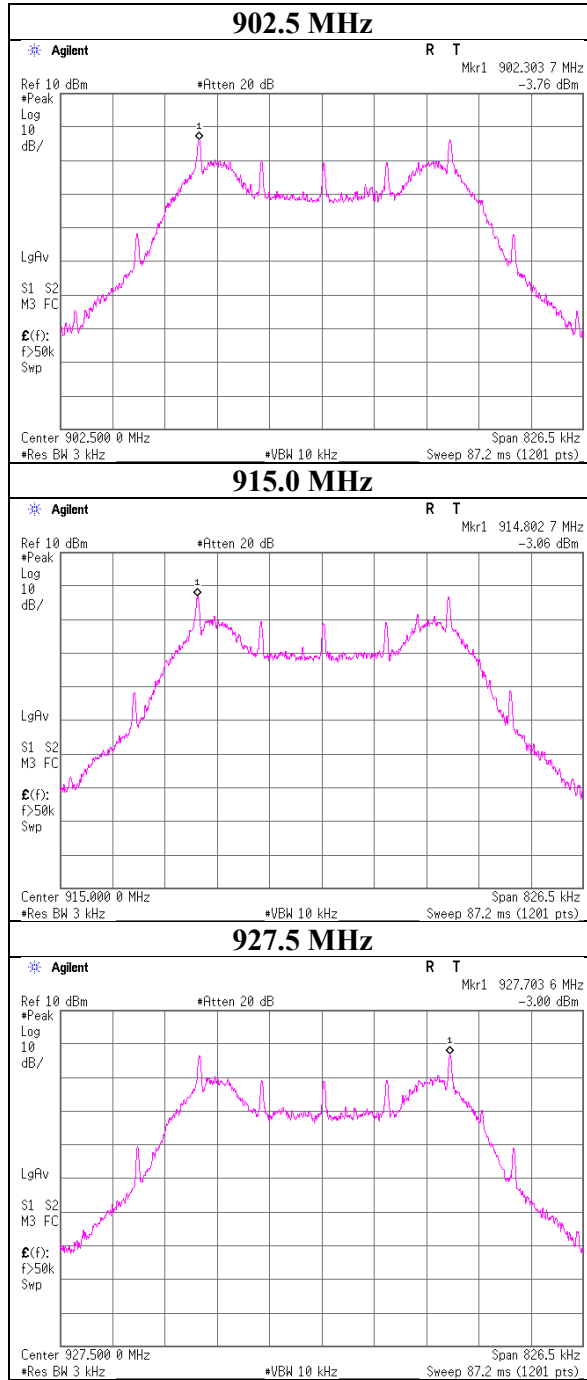

APPENDIX 2: Test instruments

Test Instruments

Test Item	LIMS ID	Description	Manufacturer	Model	Serial	Last Calibration Date	Calibration Due Date	Cal Int
RE	141425	Biconical Antenna	Schwarzbeck	BBA9106	1302	06/01/2018	06/30/2019	12
RE	141267	Logperiodic Antenna (200-1000MHz)	Schwarzbeck	VUSLP9111B	911B-192	03/21/2019	03/31/2020	12
RE	148898	Attenuator	KEYSIGHT	8491A	MY52462282	10/03/2018	10/31/2019	12
RE	141397	Coaxial Cable	UL Japan	-	-	06/13/2018	06/30/2019	12
RE	141583	Pre Amplifier	SONOMA INSTRUMENT	310	260833	02/08/2019	02/29/2020	12
RE/CE	142011	AC4_Semi Anechoic Chamber(NSA)	TDK	Semi Anechoic Chamber 3m	DA-10005	06/28/2018	06/30/2020	24
AT	141830	Power sensor	ANRITSU	MA2411B	738285	05/21/2018	05/31/2019	12
AT	141953	Torque wrench	Huber+Suhner	74 Z-0-0-21	60855	03/12/2018	03/31/2021	36
AT	141572	Thermo-Hygrometer	CUSTOM	CTH-201	3401	01/11/2019	01/31/2020	12
AT	141156	Attenuator(10dB)	Weinschel Corp	2	BL1173	11/02/2018	11/30/2019	12
AT	141279	Microwave Cable	Junkosha	MMX221-00500DMSDMS	1502S303	03/05/2019	03/31/2020	12
AT	141884	Spectrum Analyzer	AGILENT	E4448A	MY44020357	03/13/2019	03/31/2020	12
AT	141809	Power Meter	ANRITSU	ML2495A	825002	05/21/2018	05/31/2019	12
CE	141248	Attenuator	JFW Industries, Inc.	50FP-013H2 N	-	12/06/2018	12/31/2019	12
CE	141217	Coaxial cable	Fujikura/Suhner/TSJ	5D-2W/SFM141/421-010/sucoform141-P	-/04178	06/13/2018	06/30/2019	12
RE/CE	141152	EMI measurement program	TSJ	TEPTO-DV	-	-	-	-
RE/CE	142227	Measure	KOMELON	KMC-36	-	-	-	-
CE	141562	Thermo-Hygrometer	CUSTOM	CTH-201	0010	01/11/2019	01/31/2020	12
CE	141938	Terminator	TME	CT-01BP	-	12/05/2018	12/31/2019	12
CE	141358	LISN(AMN)	Schwarzbeck	NSLK8127	8127-730	07/25/2018	07/31/2019	12
CE	141357	LISN(AMN)	Schwarzbeck	NSLK8127	8127-729	07/24/2018	07/31/2019	12
CE	141950	EMI Test Receiver	Rohde & Schwarz	ESU26	100412	06/15/2018	06/30/2019	12
CE	141545	DIGITAL HiTESTER	HIOKI	3805	51201148	01/29/2019	01/31/2020	12
RE	141562	Thermo-Hygrometer	CUSTOM	CTH-201	0010	01/11/2019	01/31/2020	12
RE	141297	High Pass Filter (1.1-10GHz)	TOKYO KEIKI	TF219CD1	1001	01/10/2019	01/31/2020	12
RE	141412	Microwave Cable	Junkosha	MWX221	1305S002R(1m) / 1405S146(5m)	06/14/2018	06/30/2019	12
RE	141581	MicroWave System Amplifier	AGILENT	83017A	650	10/04/2018	10/31/2019	12
RE	141508	Horn Antenna 1-18GHz	Schwarzbeck	BBHA9120D	9120D-557	06/08/2018	06/30/2019	12
RE	141545	DIGITAL HiTESTER	HIOKI	3805	51201148	01/29/2019	01/31/2020	12
RE	142017	AC4_Semi Anechoic Chamber(SVSWR)	TDK	Semi Anechoic Chamber 3m	DA-10005	04/04/2019	04/30/2020	12

*Hyphens for Last Calibration Date, Calibration Due Date and Cal Int (month) are instruments that Calibration is not required (e.g. software), or instruments checked in advance before use.

The expiration date of the calibration is the end of the expired month.
All equipment is calibrated with valid calibrations. Each measurement data is traceable to the national or international standards.

As for some calibrations performed after the tested dates, those test equipment have been controlled by means of an unbroken chains of calibrations.

Test item: CE: Conducted Emission test
RE: Radiated Emission test
AT: Antenna Terminal Conducted test

UL Japan, Inc.
Ise EMC Lab.

4383-326 Asama-cho, Ise-shi, Mie-ken 516-0021 JAPAN
Telephone : +81 596 24 8999
Facsimile : +81 596 24 8124