



# RADIO TEST REPORT

Test Report No. : 11774441H-A-R2

**Applicant** : Murata Manufacturing Co., Ltd.  
**Type of Equipment** : Communication Module  
**Model No.** : 1MW  
**FCC ID** : VPYLB1MW  
**Test regulation** : FCC Part 15 Subpart C: 2017  
(WLAN, BT LE parts)  
**Test Result** : Complied

1. This test report shall not be reproduced in full or partial, without the written approval of UL Japan, Inc.
2. The results in this report apply only to the sample tested.
3. This sample tested is in compliance with the above regulation.
4. The test results in this report are traceable to the national or international standards.
5. This test report must not be used by the customer to claim product certification, approval, or endorsement by NVLAP, NIST, or any agency of the Federal Government.
6. This test report covers Radio technical requirements. It does not cover administrative issues such as Manual or non-Radio test related Requirements. (if applicable)
7. This report is a revised version of 11774441H-A-R1.

**Date of test:** July 12 to August 31, 2017

**Representative test engineer:**   
Takafumi Noguchi  
Engineer  
Consumer Technology Division

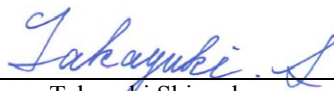
**Approved by:**   
Takayuki Shimada  
Engineer  
Consumer Technology Division

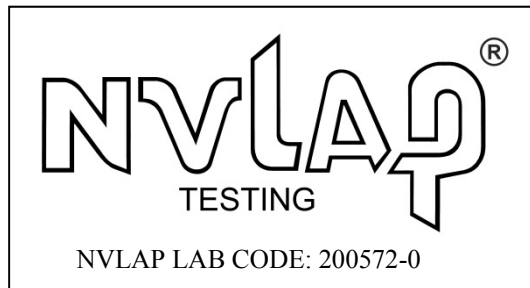

This laboratory is accredited by the NVLAP LAB CODE 200572-0, U.S.A. The tests reported herein have been performed in accordance with its terms of accreditation.  
\*As for the range of Accreditation in NVLAP, you may refer to the WEB address,  
[http://japan.ul.com/resources/emc\\_accredited/](http://japan.ul.com/resources/emc_accredited/)

**UL Japan, Inc.**

**Ise EMC Lab.**

4383-326 Asama-cho, Ise-shi, Mie-ken 516-0021 JAPAN

Telephone : +81 596 24 8999

Facsimile : +81 596 24 8124

13-EM-F0429



---

<b>CONTENTS</b>	<b>PAGE</b>
<b>SECTION 1: Customer information.....</b>	<b>4</b>
<b>SECTION 2: Equipment under test (E.U.T.).....</b>	<b>4</b>
<b>SECTION 3: Test specification, procedures &amp; results.....</b>	<b>6</b>
<b>SECTION 4: Operation of E.U.T. during testing.....</b>	<b>9</b>
<b>SECTION 5: Conducted Emission.....</b>	<b>12</b>
<b>SECTION 6: Radiated Spurious Emission .....</b>	<b>13</b>
<b>SECTION 7: Antenna Terminal Conducted Tests.....</b>	<b>15</b>
<b>APPENDIX 1: Test data .....</b>	<b>16</b>
Conducted Emission .....	16
6dB Bandwidth .....	19
Maximum Peak Output Power .....	22
Average Output Power .....	26
Radiated Spurious Emission .....	30
Conducted Spurious Emission .....	52
Power Density .....	56
99% Occupied Bandwidth .....	61
<b>APPENDIX 2: Test instruments .....</b>	<b>64</b>
<b>APPENDIX 3: Photographs of test setup .....</b>	<b>66</b>
Conducted Emission .....	66
Radiated Spurious Emission .....	67
Worst Case Position .....	68

## **SECTION 1: Customer information**

Company Name : Murata Manufacturing Co., Ltd.  
Address : 1-10-1 Higashikotari, Nagaokakyo-shi, Kyoto 617-8555 Japan  
Telephone Number : +81-75-955-6736  
Facsimile Number : +81-75-955-6634  
Contact Person : Motoo Hayashi

## **SECTION 2: Equipment under test (E.U.T.)**

### **2.1 Identification of E.U.T.**

Type of Equipment : Communication Module  
Model No. : 1MW  
Serial No. : Refer to Section 4, Clause 4.2  
Rating : VBAT: Min. 3.35 V / Typ. 3.6 V / Max. 4.2 V  
VIO: 1.8 V / 3.3 V  
\*VIO doesn't influence the RF characteristic.  
Receipt Date of Sample : June 26, 2017  
Country of Mass-production : China, Japan  
Condition of EUT : Engineering prototype  
(Not for Sale: This sample is equivalent to mass-produced items.)  
Modification of EUT : No Modification by the test lab

### **2.2 Product Description**

Model: 1MW (referred to as the EUT in this report) is a Communication Module.

### **General Specification**

Clock frequency(ies) in the system : 37.4 MHz (X'tal)

**Radio Specification**

Radio Type : Transceiver  
Power Supply (inner) : DC 3.3V

**Specification of Wireless LAN (IEEE802.11b/g/a/n-20/n-40/11ac-20/11ac-40/11ac-80)**

Type of radio	IEEE802.11b *1)	IEEE802.11g/n (20 M band) *1)	IEEE802.11a/n/ac (20 M band)	IEEE802.11n/ac (40 M band)	IEEE802.11ac (80 M band)
Frequency of operation	2412 MHz - 2462 MHz	2412 MHz - 2462 MHz	5180 MHz - 5240 MHz 5260 MHz - 5320 MHz 5500 MHz - 5720 MHz 5745 MHz - 5825 MHz	5190 MHz - 5230 MHz 5270 MHz - 5310 MHz 5510 MHz - 5710 MHz 5755 MHz - 5795 MHz	5210 MHz 5290 MHz 5530 MHz - 5690 MHz 5775 MHz
Type of modulation	DSSS (CCK, DQPSK, DBPSK)	OFDM-CCK (64QAM, 16QAM, QPSK, BPSK)	OFDM (64QAM, 16QAM, QPSK, BPSK, 256QAM(IEEE802.11ac only))		
Channel spacing	5 MHz		20 MHz	40 MHz	80 MHz
Antenna type	Monopole pattern antenna				
Antenna Gain	[RF Cable 30 mm] 2.4 GHz: 0 dBi 5 GHz: 1.5dBi [RF Cable 300 mm] 2.4 GHz: -1.3 dBi 5 GHz: -1.8 dBi				

**Bluetooth (Ver. 4.2 with EDR function)**

	Bluetooth Ver.4.2 with EDR function *1)
Frequency of operation	2402 MHz - 2480 MHz
Type of modulation	BT: FHSS (GFSK, $\pi/4$ DQPSK, 8DPSK) LE: GFSK
Channel spacing	BT: 1 MHz LE: 2 MHz
Antenna type	Monopole pattern antenna
Antenna Gain	[RF Cable 30 mm] 2.4 GHz: 0 dBi [RF Cable 300 mm] 2.4 GHz: -1.3 dBi

\*1) This test report applies to IEEE802.11b/g/n-20 (2412 MHz - 2462 MHz) and Bluetooth Ver.4.2 with EDR function (LE part: 2402 MHz - 2480 MHz).

\* WLAN and Bluetooth do not transmit simultaneously.

### **SECTION 3: Test specification, procedures & results**

#### **3.1 Test Specification**

Test Specification : FCC Part 15 Subpart C  
FCC Part 15 final revised on June 14, 2017 and effective July 14, 2017

Title : FCC 47CFR Part15 Radio Frequency Device Subpart C Intentional Radiators  
Section 15.207 Conducted limits  
Section 15.247 Operation within the bands 902-928MHz,  
2400-2483.5MHz, and 5725-5850MHz

\* The revision on August 29, 2017, does not affect the test specification applied to the EUT.

#### **3.2 Procedures and results**

Item	Test Procedure	Specification	Worst margin	Results	Remarks
Conducted Emission	FCC: ANSI C63.10-2013 6. Standard test methods IC: RSS-Gen 8.8	FCC: Section 15.207 IC: RSS-Gen 8.8	QP 14.0 dB, 24.00020 MHz, N AV 12.2 dB, 24.00020 MHz, N/L	Complied	-
6dB Bandwidth	FCC: KDB 558074 D01 DTS Meas Guidance v04 IC: -	FCC: Section 15.247(a)(2) IC: RSS-247 5.2(a)	See data.	Complied	Conducted
Maximum Peak Output Power	FCC: KDB 558074 D01 DTS Meas Guidance v04 IC: RSS-Gen 6.12	FCC: Section 15.247(b)(3) IC: RSS-247 5.4(d)		Complied	Conducted
Power Density	FCC: KDB 558074 D01 DTS Meas Guidance v04 IC: -	FCC: Section 15.247(e) IC: RSS-247 5.2(b)		Complied	Conducted
Spurious Emission Restricted Band Edges	FCC: KDB 558074 D01 DTS Meas Guidance v04 IC: RSS-Gen 6.13	FCC: Section15.247(d) IC: RSS-247 5.5 RSS-Gen 8.9 RSS-Gen 8.10	0.4 dB 2390.000 MHz, AV, Hori.	Complied	Conducted (below 30 MHz)/ Radiated (above 30 MHz) *1)

Note: UL Japan, Inc.'s EMI Work Procedures No. 13-EM-W0420 and 13-EM-W0422.

\*1) Radiated test was selected over 30 MHz based on section 15.247(d) and KDB 558074 D01 DTS Meas Guidance v04 12.2.7.

\* In case any questions arise about test procedure, ANSI C63.10: 2013 is also referred.

#### **FCC Part 15.31 (e)**

The RF Module has its own regulator.

The RF Module is constantly provided voltage (DC 3.3 V) through the regulator regardless of input voltage.  
Therefore, this EUT complies with the requirement.

#### **FCC Part 15.203/212 Antenna requirement**

The EUT has a unique coupling/antenna connector (Connector Type: JSC).  
Therefore the equipment complies with the requirement of 15.203.

**UL Japan, Inc.**

**Ise EMC Lab.**

4383-326 Asama-cho, Ise-shi, Mie-ken 516-0021 JAPAN

Telephone : +81 596 24 8999

Facsimile : +81 596 24 8124

### 3.3 Addition to standard

Item	Test Procedure	Specification	Worst margin	Results	Remarks
99% Occupied Bandwidth	IC: RSS-Gen 6.6	IC: -	N/A	-	Conducted

Other than above, no addition, exclusion nor deviation has been made from the standard.

### 3.4 Uncertainty

#### EMI

The following uncertainties have been calculated to provide a confidence level of 95 % using a coverage factor  $k = 2$ .  
Ise EMC Lab.

Antenna terminal test	Uncertainty (+/-)
RF output power	1.2 dB
Antenna terminal conducted emission / Power density / Burst power	3.1 dB
Adjacent channel power / Channel power	
Below 3 GHz	1.8 dB
3 GHz to 6 GHz	2.7 dB

Frequency range	Conducted emission using AMN(LISN) (+/-)
0.009 MHz - 0.15 MHz	3.1 dB
0.15 MHz - 30 MHz	2.5 dB

Test distance	Radiated emission (+/-) 9 kHz - 30 MHz
3 m	3.8 dB
10 m	3.6 dB

Polarity	Radiated emission (Below 1 GHz)			
	(3 m*) (+/-)		(10 m*) (+/-)	
	30 MHz - 200 MHz	200 MHz - 1000 MHz	30 MHz - 200 MHz	200 MHz - 1000 MHz
Horizontal	5.0 dB	5.3 dB	5.0 dB	5.0 dB
Vertical	5.2 dB	6.3 dB	5.0 dB	5.0 dB

Radiated emission (Above 1 GHz)				
(3 m*) (+/-)		(1 m*) (+/-)		(10 m*) (+/-)
1 GHz - 6 GHz	6 GHz - 18 GHz	10 GHz - 26.5 GHz	26.5 GHz - 40 GHz	1 GHz - 18 GHz
5.2 dB	5.5 dB	5.5 dB	5.4 dB	5.5 dB

\*Measurement distance

#### Conducted Emission test

The data listed in this test report has enough margin, more than the site margin.

#### Radiated emission test

The data listed in this report meets the limits unless the uncertainty is taken into consideration.

**UL Japan, Inc.**

**Ise EMC Lab.**

4383-326 Asama-cho, Ise-shi, Mie-ken 516-0021 JAPAN

Telephone : +81 596 24 8999

Facsimile : +81 596 24 8124

### 3.5 Test Location

UL Japan, Inc. Ise EMC Lab. \*NVLAP Lab. code: 200572-0  
4383-326 Asama-cho, Ise-shi, Mie-ken 516-0021 JAPAN  
Telephone: +81 596 24 8999, Facsimile: +81 596 24 8124

Test site	IC Registration Number	Width x Depth x Height (m)	Size of reference ground plane (m) / horizontal conducting plane	Other rooms	Maximum measurement distance
No.1 semi-anechoic chamber	2973C-1	19.2 x 11.2 x 7.7	7.0 x 6.0	No.1 Power source room	10 m
No.2 semi-anechoic chamber	2973C-2	7.5 x 5.8 x 5.2	4.0 x 4.0	-	3 m
No.3 semi-anechoic chamber	2973C-3	12.0 x 8.5 x 5.9	6.8 x 5.75	No.3 Preparation room	3 m
No.3 shielded room	-	4.0 x 6.0 x 2.7	N/A	-	-
No.4 semi-anechoic chamber	2973C-4	12.0 x 8.5 x 5.9	6.8 x 5.75	No.4 Preparation room	3 m
No.4 shielded room	-	4.0 x 6.0 x 2.7	N/A	-	-
No.5 semi-anechoic chamber	-	6.0 x 6.0 x 3.9	6.0 x 6.0	-	-
No.6 shielded room	-	4.0 x 4.5 x 2.7	4.0 x 4.5	-	-
No.6 measurement room	-	4.75 x 5.4 x 3.0	4.75 x 4.15	-	-
No.7 shielded room	-	4.7 x 7.5 x 2.7	4.7 x 7.5	-	-
No.8 measurement room	-	3.1 x 5.0 x 2.7	N/A	-	-
No.9 measurement room	-	8.8 x 4.6 x 2.8	2.4 x 2.4	-	-
No.11 measurement room	-	6.2 x 4.7 x 3.0	4.8 x 4.6	-	-

\* Size of vertical conducting plane (for Conducted Emission test) : 2.0 m x 2.0m for No.1, No.2, No.3, and No.4 semi-anechoic chambers and No.3 and No.4 shielded rooms.

### 3.6 Test data, Test instruments, and Test set up

Refer to APPENDIX.

**UL Japan, Inc.**

**Ise EMC Lab.**

4383-326 Asama-cho, Ise-shi, Mie-ken 516-0021 JAPAN

Telephone : +81 596 24 8999

Facsimile : +81 596 24 8124



## **SECTION 4: Operation of E.U.T. during testing**

### **4.1 Operating Mode(s)**

Test operating mode was determined as follows according to “Section 1 of 6 802.11 a/b/g/n testing - Managing Complex Regulatory Approvals - ” of TCB Council Workshop October 2009.

<b>Mode</b>	<b>Remarks*</b>
IEEE 802.11b (11b)	5.5 Mbps, PN9
IEEE 802.11g (11g)	36 Mbps, PN9
IEEE 802.11n 20 MHz BW (11n-20)	6 Mbps, PN9
Bluetooth Low Energy (BT LE)	Maximum Packet Size, PRBS9
*The worst condition was determined based on the test result of Maximum Peak Output Power (Mid Channel)	
*Power of the EUT was set by the software as follows; Power settings: 11b:17 11g: 12.5 11n: 12 BT LE: config:0218 Software: WLAN: MFG Tool Version 7.45.0.0 BTLE: Bluetool 1.8.9.3 *This setting of software is the worst case. Any conditions under the normal use do not exceed the condition of setting. In addition, end users cannot change the settings of the output power of the product.	

\*The details of Operating mode(s) for WLAN

<b>Test Item</b>	<b>Operating Mode</b>	<b>Tested frequency</b>
Conducted Emission, Radiated Spurious Emission (Below 1GHz) Conducted Spurious Emission	Tx 11n-20 *1)	2462 MHz
Radiated Spurious Emission (Above 1GHz)	Tx 11b Tx 11g Tx 11n-20	2412 MHz 2437 MHz 2462 MHz
6dB Bandwidth, Maximum Peak Output Power, Power Density, 99% Occupied Bandwidth	Tx 11b Tx 11g Tx 11n-20	2412 MHz 2437 MHz 2462 MHz
*1) The mode was tested as a representative, because it had the highest power at antenna terminal test.		

\*The details of Operating mode(s) for BT LE

<b>Test Item</b>	<b>Operating Mode</b>	<b>Tested frequency</b>
Conducted Emission, 6dB Bandwidth, Maximum Peak Output Power, Power Density, 99% Occupied Bandwidth, Spurious Emission (Radiated / Conducted)	Tx BT LE	2402 MHz 2440 MHz 2480 MHz

**UL Japan, Inc.**

**Ise EMC Lab.**

4383-326 Asama-cho, Ise-shi, Mie-ken 516-0021 JAPAN

Telephone : +81 596 24 8999

Facsimile : +81 596 24 8124

## 4.2 Configuration and peripherals

### For Conducted Emission test

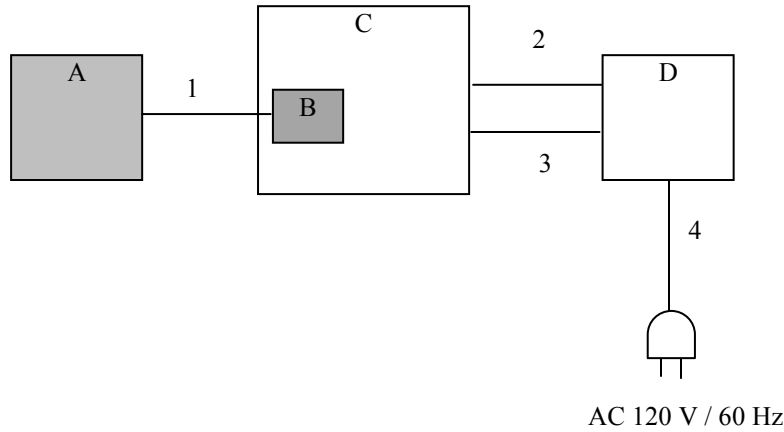

### For all tests other than Conducted Emission test

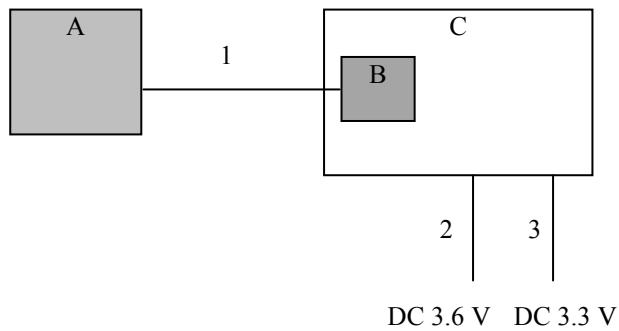

\* Cabling and setup(s) were taken into consideration and test data was taken under worse case conditions.

**Description of EUT and Support equipment**

No.	Item	Model number	Serial number	Manufacturer	Remarks
A	Monopole pattern antenna	Type1KT-30	No.1	Murata Manufacturing Co., Ltd.	EUT *5)
B	Communication Module	1MW	46 *2) 45 *3) 9 *4)	Murata Manufacturing Co., Ltd.	EUT
C	Jig Board	1MW EVB ES1 P2ML5840	-	Murata Manufacturing Co., Ltd.	*6)
D	Regulated DC Power Supply	PW16-5ADP	171116437	TEXIO	-

**List of cables used**

No.	Name	Length (m)	Shield		Remarks
			Cable	Connector	
1	Signal Cable	0.03	Unshielded	Unshielded	*5)
2	DC Cable	0.5 *1) 2.5 *2)	Unshielded	Unshielded	-
3	DC Cable	0.5 *1) 2.5 *2)	Unshielded	Unshielded	-
4	AC Cable	1.00	Unshielded	Unshielded	-

\*1) Used for Conducted Emission test

\*2) Used for Radiated Emission test

\*3) Used for Antenna Terminal Conducted test (Except for BTLE)

\*4) Used for Antenna Terminal Conducted test (BTLE)

\*5) Used for all tests except for Antenna Terminal Conducted test

\*6) The test was performed with the module that as normal assumed implementation conditions.  
The use of a jig does not influence on the test result.

## **SECTION 5: Conducted Emission**

### **Test Procedure and conditions**

EUT was placed on a urethane platform of nominal size, 1.0 m by 1.5 m, raised 0.8 m above the conducting ground plane.

The rear of tabletop was located 40 cm to the vertical conducting plane. The rear of EUT, including peripherals aligned and flushed with rear of tabletop. All other surfaces of tabletop were at least 80cm from any other grounded conducting surface. EUT was located 80 cm from a Line Impedance Stabilization Network (LISN) / Artificial mains Network (AMN) and excess AC cable was bundled in center.

#### 1) For the tests on EUT with other peripherals (as a whole system)

I/O cables that were connected to the peripherals were bundled in center. They were folded back and forth forming a bundle 30 cm to 40 cm long and were hanged at a 40 cm height to the ground plane. All unused 50ohm connectors of the LISN (AMN) were resistivity terminated in 50 ohm when not connected to the measuring equipment.

The AC Mains Terminal Continuous disturbance Voltage has been measured with the EUT in a Semi Anechoic Chamber.

The EUT was connected to a LISN (AMN).

An overview sweep with peak detection has been performed.

The test results and limit are rounded off to one decimal place, so some differences might be observed.

<b>Detector</b>	<b>: QP and CISPR AV</b>
<b>Measurement range</b>	<b>: 0.15 MHz – 30 MHz</b>
<b>Test data</b>	<b>: APPENDIX</b>
<b>Test result</b>	<b>: Pass</b>

## **SECTION 6: Radiated Spurious Emission**

### **Test Procedure**

It was measured based on "11.0 Emissions in non-restricted frequency bands" of "KDB 558074 D01 DTS Meas Guidance v04".

[For below 1 GHz]

EUT was placed on a urethane platform of nominal size, 0.5 m by 1.0 m, raised 0.8 m above the conducting ground plane. The Radiated Electric Field Strength has been measured in a Semi Anechoic Chamber with a ground plane.

[For above 1 GHz]

EUT was placed on a urethane platform of nominal size, 0.5 m by 0.5 m, raised 1.5 m above the conducting ground plane.

The Radiated Electric Field Strength has been measured in a Semi Anechoic Chamber with absorbent materials lined on a ground plane.

The height of the measuring antenna varied between 1 and 4 m and EUT was rotated a full revolution in order to obtain the maximum value of the electric field strength.

The measurements were performed for both vertical and horizontal antenna polarization with the Test Receiver, or the Spectrum Analyzer.

The measurements were made with the following detector function of the test receiver and the Spectrum analyzer (in linear mode).

The test was made with the detector (RBW/VBW) in the following table.

When using Spectrum analyzer, the test was made with adjusting span to zero by using peak hold.

### **Test Antennas are used as below;**

Frequency	30 MHz to 200 MHz	200 MHz to 1 GHz	Above 1 GHz
Antenna Type	Biconical	Logperiodic	Horn

In any 100 kHz bandwidth outside the restricted band in which the spread spectrum intentional radiator is operating, the radio frequency power that is produced by the intentional radiator confirmed 20 dB below that in the 100 kHz bandwidth within the band that contains the highest level of the desired power, based on a radiated measurement.

**20 dBc was applied to the frequency over the limit of FCC 15.209 / Table 4 of RSS-Gen 8.9(IC) and outside the restricted band of FCC15.205 / Table 6 of RSS-Gen 8.10 (IC).**

Frequency	Below 1 GHz	Above 1 GHz		20 dBc
Instrument used	Test Receiver	Spectrum Analyzer		Spectrum Analyzer
Detector	QP	PK	AV *1)	PK
IF Bandwidth	BW 120 kHz	RBW: 1 MHz VBW: 3 MHz	Average Power Method: RBW: 1 MHz VBW: 3 MHz Detector: Power Averaging (RMS) Trace: 100 traces If duty cycle was less than 98%, a duty factor was added to the results.	RBW: 100 kHz VBW: 300kHz
Test Distance	3 m	3.75 m *2) (1 GHz – 10 GHz), 1.0 m *3) (10 GHz – 26.5 GHz)		3.75 m *2) (1 GHz – 10 GHz), 1.0 m *3) (10 GHz – 26.5 GHz)

\*1) Average Power Measurement was performed based on 6.0 & 12.2.5 of "KDB 558074 D01 DTS Meas Guidance v04".

\*2) Distance Factor:  $20 \times \log(3.75 \text{ m} / 3.0 \text{ m}) = 1.94 \text{ dB}$

\*3) Distance Factor:  $20 \times \log(1.0 \text{ m} / 3.0 \text{ m}) = -9.5 \text{ dB}$

- The noise levels were confirmed at each position of X, Y and Z axes of EUT (Antenna and Module) to see the position of maximum noise, and the test was made at the position that has the maximum noise.

The test results and limit are rounded off to one decimal place, so some differences might be observed.

**Measurement range : 30 MHz - 26.5 GHz**  
**Test data : APPENDIX**  
**Test result : Pass**

## **SECTION 7: Antenna Terminal Conducted Tests**

### **Test Procedure**

The tests were made with below setting connected to the antenna port.

<b>Test</b>	<b>Span</b>	<b>RBW</b>	<b>VBW</b>	<b>Sweep time</b>	<b>Detector</b>	<b>Trace</b>	<b>Instrument used</b>
6dB Bandwidth	20 MHz	100 kHz	300 kHz	Auto	Peak	Max Hold	Spectrum Analyzer
99% Occupied Bandwidth *1)	Enough width to display emission skirts	1 to 5 % of OBW	Three times of RBW	Auto	Peak	Max Hold	Spectrum Analyzer
Maximum Peak Output Power	-	-	-	Auto	Peak/Average *2)	-	Power Meter (Sensor: 50 MHz BW)
Peak Power Density	1.5 times the 6dB Bandwidth	3 kHz	10 kHz	Auto	Peak	Max Hold	Spectrum Analyzer *3)
Conducted Spurious Emission *4)	9kHz to 150kHz	200 Hz	620 Hz	Auto	Peak	Max Hold	Spectrum Analyzer
	150kHz to 30MHz	9.1 kHz	27 kHz				

\*1) Peak hold was applied as Worst-case measurement.

\*2) Reference data

\*3) Section 10.2 Method PKPSD (peak PSD) of "KDB 558074 D01 DTS Meas Guidance v04".

\*4) In the frequency range below 30MHz, RBW was narrowed to separate the noise contents.

Then, wide-band noise near the limit was checked separately, however the noise was low enough as shown in the chart.  
(9 kHz - 150 kHz: RBW = 200 Hz, 150 kHz - 30 MHz: RBW = 9.1 kHz).

The test results and limit are rounded off to two decimals place, so some differences might be observed.

**Test data : APPENDIX**

**Test result : Pass**

**UL Japan, Inc.**

**Ise EMC Lab.**

4383-326 Asama-cho, Ise-shi, Mie-ken 516-0021 JAPAN

Telephone : +81 596 24 8999

Facsimile : +81 596 24 8124

**APPENDIX 1: Test data**

**Conducted Emission**

**DATA OF CONDUCTED EMISSION TEST**

UL Japan, Inc. Ise EMC Lab. No.3 Semi Anechoic Chamber  
Date : 2017/07/20

Report No. : 11774441H

Temp./Humi. : 24deg. C / 56% RH  
Engineer : Tomoki Matsui

Mode / Remarks : Tx 11n-20 2462MHz

LIMIT : FCC15.207 QP  
FCC15.207 AV

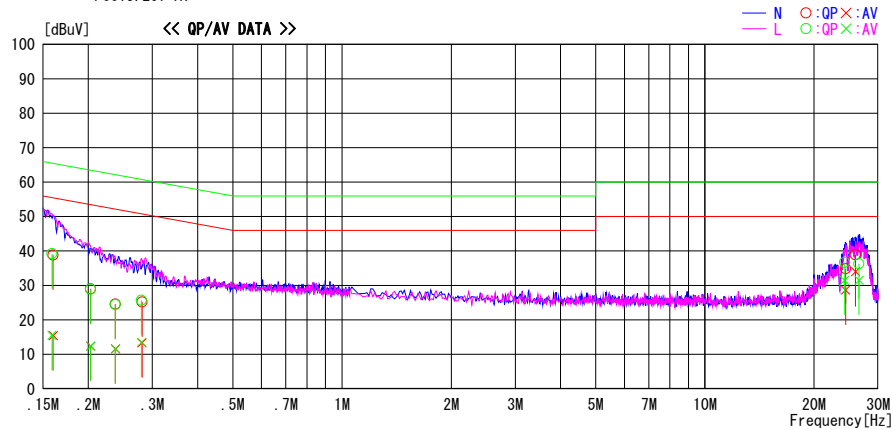

Frequency [MHz]	Reading Level		Corr. Factor	Results		Limit		Margin		Phase	Comment
	QP [dBuV]	AV [dBuV]		QP [dBuV]	AV [dBuV]	QP [dBuV]	AV [dBuV]	QP [dB]	AV [dB]		
0.15992	25.6	2.2	13.2	38.8	15.4	65.5	55.5	26.7	40.1	N	
0.20308	15.8	-0.8	13.2	29.0	12.4	63.5	53.5	34.5	41.1	N	
0.23750	11.4	-1.6	13.2	24.6	11.6	62.2	52.2	37.6	40.6	N	
0.28125	12.0	0.1	13.2	25.2	13.3	60.8	50.8	35.6	37.5	N	
24.41046	20.3	14.0	14.6	34.9	28.6	60.0	50.0	25.1	21.4	N	
25.98873	24.2	19.3	14.7	38.9	34.0	60.0	50.0	21.1	16.0	N	
0.15875	26.0	2.3	13.2	39.2	15.5	65.5	55.5	26.3	40.0	L	
0.20308	15.7	-0.8	13.2	28.9	12.4	63.5	53.5	34.6	41.1	L	
0.23750	11.3	-1.6	13.2	24.5	11.6	62.2	52.2	37.7	40.6	L	
0.28008	12.5	0.3	13.2	25.7	13.5	60.8	50.8	35.1	37.3	L	
24.24963	22.1	16.9	14.6	36.7	31.5	60.0	50.0	23.3	18.5	L	
26.58873	21.6	16.8	14.7	36.3	31.5	60.0	50.0	23.7	18.5	L	

CHART: WITH FACTOR Peak hold data. CALCULATION: RESULT = READING + C.F (LISN + CABLE + ATTN)  
Except for the above table: adequate margin data below the limits.



## Conducted Emission

### DATA OF CONDUCTED EMISSION TEST

UL Japan, Inc. Ise EMC Lab. No.3 Semi Anechoic Chamber  
Date : 2017/07/20

Report No. : 11774441H

Temp./Humi. : 24deg. C / 56% RH  
Engineer : Tomoki Matsui

Mode / Remarks : Tx BTLE 2402MHz

LIMIT : FCC15.207 QP  
FCC15.207 AV

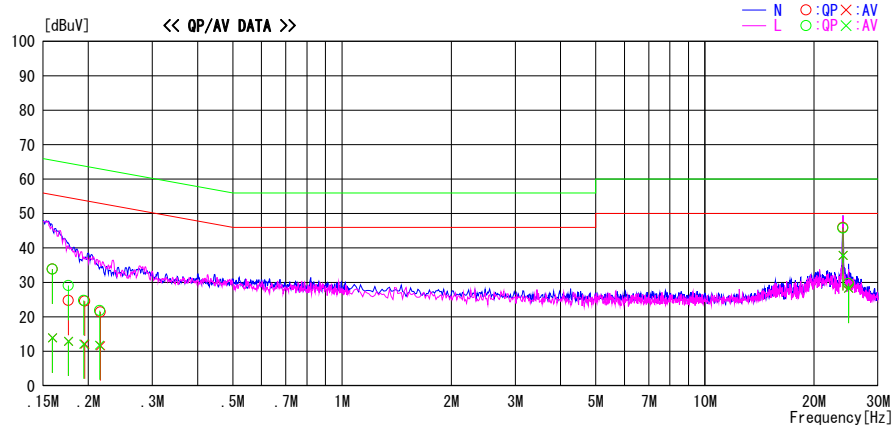

Frequency [MHz]	Reading Level		Corr. Factor [dB]	Results		Limit		Margin		Phase	Comment
	QP [dBuV]	AV [dBuV]		QP [dBuV]	AV [dBuV]	QP [dBuV]	AV [dBuV]	QP [dB]	AV [dB]		
0.15933	20.7	0.7	13.2	33.9	13.9	65.5	55.5	31.6	41.6	N	
0.17625	11.6	-0.3	13.2	24.8	12.9	64.7	54.7	39.9	41.8	N	
0.19550	11.4	-1.1	13.2	24.6	12.1	63.8	53.8	39.2	41.7	N	
0.21592	8.2	-1.6	13.2	21.4	11.6	63.0	53.0	41.6	41.4	N	
24.00020	31.4	23.2	14.6	46.0	37.8	60.0	50.0	14.0	12.2	N	
24.87789	15.0	13.7	14.6	29.6	28.3	60.0	50.0	30.4	21.7	N	
0.15933	20.7	0.7	13.2	33.9	13.9	65.5	55.5	31.6	41.6	L	
0.17625	15.9	-0.3	13.2	29.1	12.9	64.7	54.7	35.6	41.8	L	
0.19433	11.6	-1.1	13.2	24.8	12.1	63.8	53.8	39.0	41.7	L	
0.21475	8.6	-1.4	13.2	21.8	11.8	63.0	53.0	41.2	41.2	L	
24.00002	31.2	23.2	14.6	45.8	37.8	60.0	50.0	14.2	12.2	L	
24.87796	15.1	13.7	14.6	29.7	28.3	60.0	50.0	30.3	21.7	L	

CHART: WITH FACTOR, Peak hold data. CALCULATION: RESULT = READING + C.F(LISN + ATTN + CABLE)  
Except for the above table : adequate margin data below the limits.

## Conducted Emission

Test place	Ise EMC Lab. No.3 Semi Anechoic Chamber
Report No.	11774441H
Date	July 20, 2017
Temperature / Humidity	24 deg. C / 56 % RH
Engineer	Tomoki Matsui
Mode	Tx BT LE

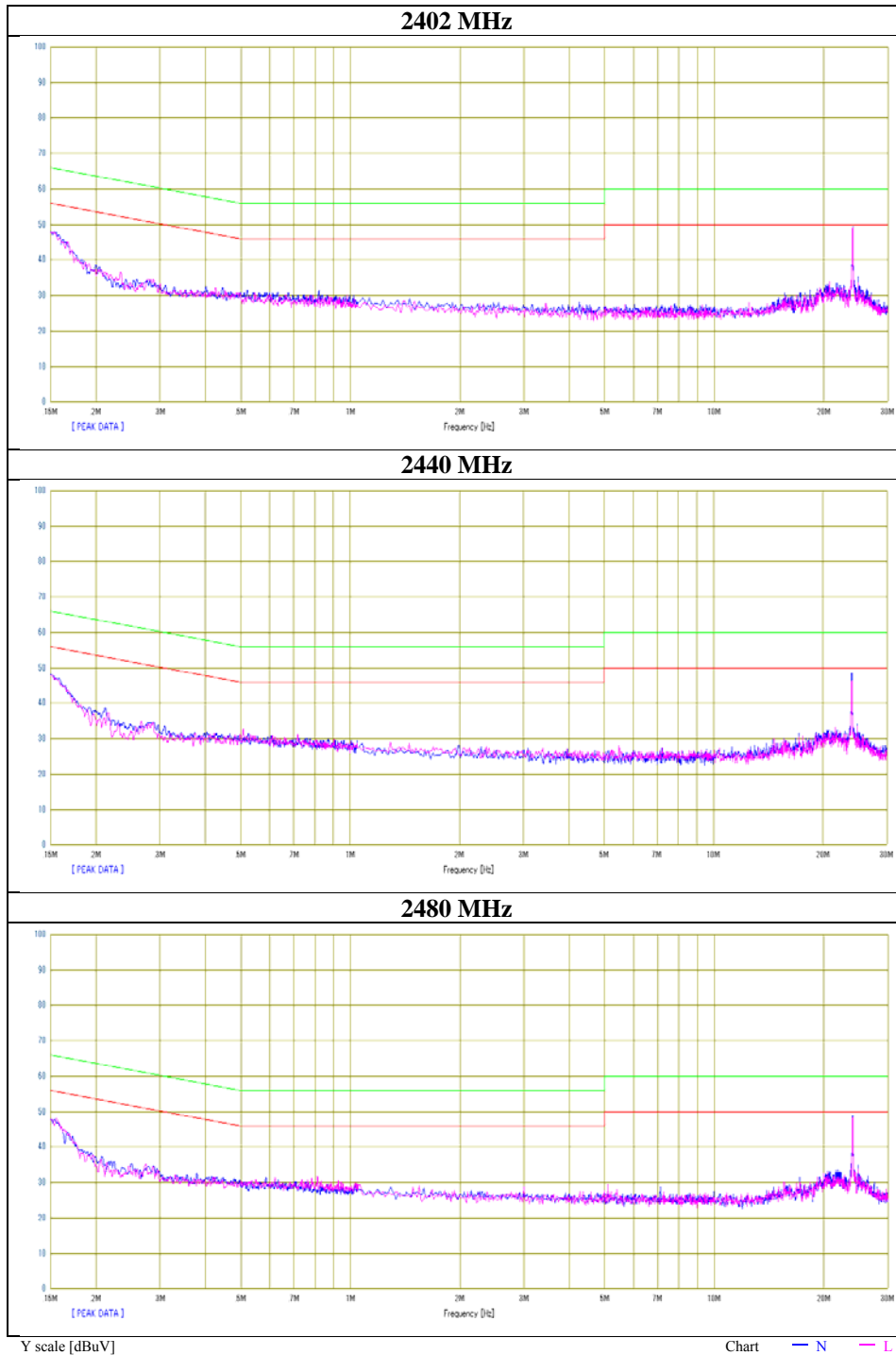

**UL Japan, Inc.**

**Ise EMC Lab.**

4383-326 Asama-cho, Ise-shi, Mie-ken 516-0021 JAPAN

Telephone : +81 596 24 8999

Facsimile : +81 596 24 8124

### 6dB Bandwidth

Test place Ise EMC Lab. No.6 Measurement Room  
Report No. 11774441H  
Date July 13, 2017 July 14, 2017  
Temperature / Humidity 24 deg. C / 62 % RH 25 deg. C / 58 % RH  
Engineer Takafumi Noguchi Takumi Shimada  
Mode Tx

Mode	Frequency [MHz]	6dB Bandwidth [MHz]	Limit [kHz]
11b	2412	8.341	> 500
	2437	8.205	> 500
	2462	8.712	> 500
11g	2412	16.264	> 500
	2437	16.418	> 500
	2462	15.953	> 500
11n-20	2412	17.268	> 500
	2437	17.715	> 500
	2462	16.711	> 500
BT LE	2402	0.715	> 500
	2440	0.707	> 500
	2480	0.715	> 500

### 6dB Bandwidth

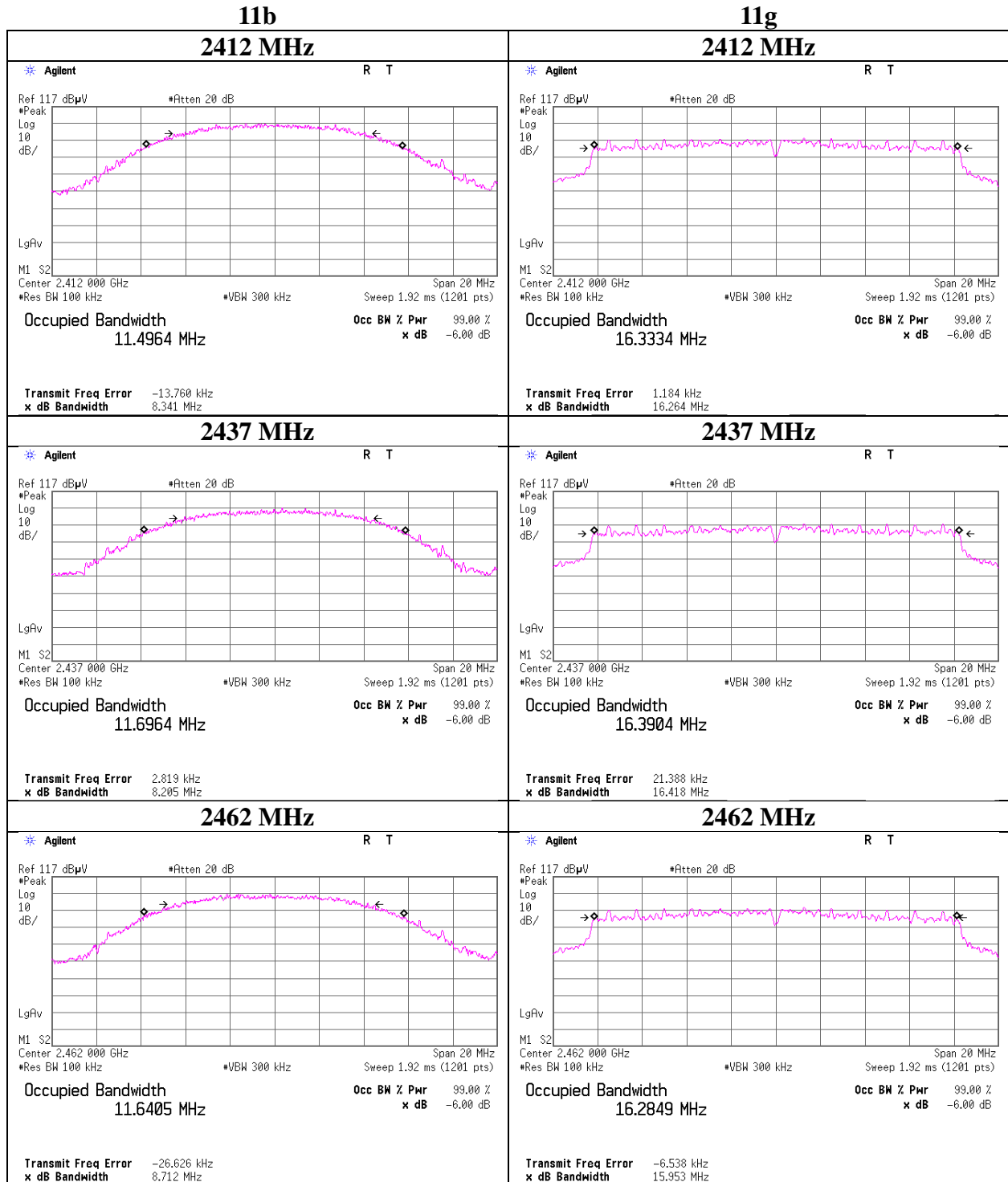

**UL Japan, Inc.**

**Ise EMC Lab.**

4383-326 Asama-cho, Ise-shi, Mie-ken 516-0021 JAPAN

Telephone : +81 596 24 8999

Facsimile : +81 596 24 8124

### 6dB Bandwidth

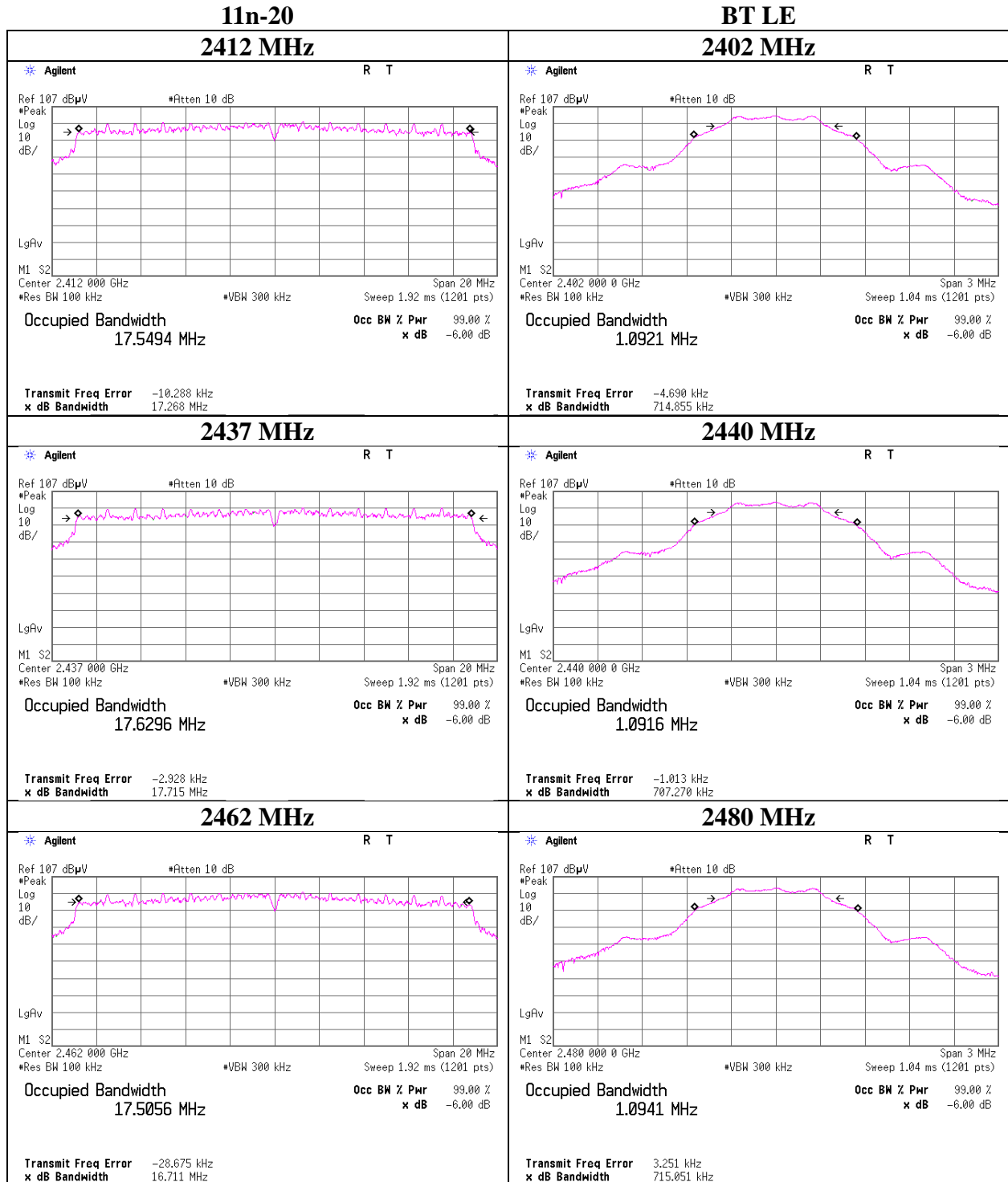

**UL Japan, Inc.**

**Ise EMC Lab.**

4383-326 Asama-cho, Ise-shi, Mie-ken 516-0021 JAPAN

Telephone : +81 596 24 8999

Facsimile : +81 596 24 8124

### Maximum Peak Output Power

Test place	Ise EMC Lab. No.6 Measurement Room	
Report No.	11774441H	
Date	July 13, 2017	July 16, 2017
Temperature / Humidity	24 deg. C / 62 % RH	27 deg. C / 42 % RH
Engineer	Takafumi Noguchi	Takafumi Noguchi
Mode	Tx 11b	

11b

Freq. [MHz]	Reading [dBm]	Cable Loss [dB]	Atten. Loss [dB]	Result		Limit		Margin [dB]
				[dBm]	[mW]	[dBm]	[mW]	
2412	9.43	0.80	10.19	20.42	110.15	30.00	1000	9.58
2437	9.06	0.80	10.19	20.05	101.16	30.00	1000	9.95
2462	9.46	0.80	10.19	20.45	110.92	30.00	1000	9.55

Sample Calculation:

Result = Reading + Cable Loss (including the cable(s) customer supplied) + Attenuator Loss

Antenna 1, 2437MHz

Rate	Reading	Remark
[Mbps]	[dBm]	
1	8.48	
2	8.91	
5.5	9.06	*
11	8.96	

\*: Worst Rate

All comparison were carried out on same frequency and measurement factors.

### Maximum Peak Output Power

Test place	Ise EMC Lab. No.6 Measurement Room
Report No.	11774441H
Date	July 13, 2017
Temperature / Humidity	24 deg. C / 62 % RH
Engineer	Takafumi Noguchi
Mode	Tx 11g

11g

Freq. [MHz]	Reading [dBm]	Cable Loss [dB]	Atten. Loss [dB]	Result		Limit		Margin [dB]
				[dBm]	[mW]	[dBm]	[mW]	
2412	12.17	0.80	10.19	23.16	207.01	30.00	1000	6.84
2437	11.94	0.80	10.19	22.93	196.34	30.00	1000	7.07
2462	12.15	0.80	10.19	23.14	206.06	30.00	1000	6.86

Sample Calculation:

Result = Reading + Cable Loss (including the cable(s) customer supplied) + Attenuator Loss

Antenna 1, 2437 MHz

Rate [Mbps]	Reading [dBm]	Remark
6	11.24	
9	11.50	
12	11.46	
18	11.88	
24	11.31	
36	11.94	*
48	11.42	
54	11.74	

\*: Worst Rate

All comparison were carried out on same frequency and measurement factors.

### Maximum Peak Output Power

Test place	Ise EMC Lab. No.6 Measurement Room
Report No.	11774441H
Date	July 13, 2017
Temperature / Humidity	24 deg. C / 62 % RH
Engineer	Takafumi Noguchi
Mode	Tx 11n-20

11n-20

Freq. [MHz]	Reading [dBm]	Cable Loss [dB]	Atten. Loss [dB]	Result		Limit		Margin [dB]
				[dBm]	[mW]	[dBm]	[mW]	
2412	12.60	0.80	10.19	23.59	228.56	30.00	1000	6.41
2437	12.30	0.80	10.19	23.29	213.30	30.00	1000	6.71
2462	12.74	0.80	10.19	23.73	236.05	30.00	1000	6.27

Sample Calculation:

Result = Reading + Cable Loss (including the cable(s) customer supplied) + Attenuator Loss

Antenna 1, 2437 MHz

MCS Number	Reading [dBm]	Remark
0	12.17	
1	12.04	
2	11.86	
3	11.97	
4	12.06	
5	11.55	
6	12.30	*
7	11.91	

\*: Worst Rate

All comparison were carried out on same frequency and measurement factors.



### Maximum Peak Output Power

Test place Ise EMC Lab. No.11 Measurement Room  
Report No. 11774441H  
Date August 31, 2017  
Temperature / Humidity 24 deg. C / 49 % RH  
Engineer Takafumi Noguchi  
Mode Tx BT LE

Freq. [MHz]	Reading [dBm]	Cable Loss [dB]	Atten. Loss [dB]	Result		Limit		Margin [dB]
				[dBm]	[mW]	[dBm]	[mW]	
2402	-5.08	0.80	10.01	5.73	3.74	30.00	1000	24.27
2440	-7.52	0.80	10.01	3.29	2.13	30.00	1000	26.71
2480	-7.25	0.80	10.01	3.56	2.27	30.00	1000	26.44

Sample Calculation:

Result = Reading + Cable Loss (including the cable(s) customer supplied) + Attenuator Loss

**Average Output Power**  
**(Reference data for RF Exposure / SAR testing)**

Test place : Ise EMC Lab. No.6 Measurement Room  
Report No. : 11774441H  
Date : July 13, 2017 July 16, 2017  
Temperature / Humidity : 24 deg. C / 62 % RH 27 deg. C / 42 % RH  
Engineer : Takafumi Noguchi Takafumi Noguchi  
Mode : Tx

**11b 1 Mbps**

Freq. [MHz]	Reading [dBm]	Cable Loss [dB]	Atten. Loss [dB]	Result (Time average)		Duty factor [dB]	Result (Burst power average)	
				[dBm]	[mW]		[dBm]	[mW]
2412	5.99	0.80	10.19	16.98	49.89	0.00	16.98	49.89
2437	5.48	0.80	10.19	16.47	44.36	0.00	16.47	44.36
2462	5.92	0.80	10.19	16.91	49.09	0.00	16.91	49.09

**11g 6 Mbps**

Freq. [MHz]	Reading [dBm]	Cable Loss [dB]	Atten. Loss [dB]	Result (Time average)		Duty factor [dB]	Result (Burst power average)	
				[dBm]	[mW]		[dBm]	[mW]
2412	2.67	0.80	10.19	13.66	23.23	0.06	13.72	23.55
2437	2.46	0.80	10.19	13.45	22.13	0.06	13.51	22.44
2462	2.76	0.80	10.19	13.75	23.71	0.06	13.81	24.04

**11n-20 MCS 0**

Freq. [MHz]	Reading [dBm]	Cable Loss [dB]	Atten. Loss [dB]	Result (Time average)		Duty factor [dB]	Result (Burst power average)	
				[dBm]	[mW]		[dBm]	[mW]
2412	1.41	0.80	10.19	12.40	17.38	0.07	12.47	17.66
2437	1.27	0.80	10.19	12.26	16.83	0.07	12.33	17.10
2462	1.56	0.80	10.19	12.55	17.99	0.07	12.62	18.28

Sample Calculation:

Result (Time average) = Reading + Cable Loss (including the cable(s) customer supplied) + Attenuator Loss  
Result (Burst power average) = Time average + Duty factor

**The average output power was measured with the lowest order modulation and  
lowest data rate configuration in each IEEE 802.11 mode based on KDB 248227 D01.**

**Average Output Power**  
**(Reference data for RF Exposure / SAR testing)**

Test place : Ise EMC Lab. No.11 Measurement Room  
Report No. : 11774441H  
Date : August 31, 2017  
Temperature / Humidity : 24 deg. C / 49 % RH  
Engineer : Takafumi Noguchi  
Mode : Tx BT LE

Freq. [MHz]	Reading [dBm]	Cable Loss [dB]	Atten. Loss [dB]	Result (Time average)		Duty factor [dB]	Result (Burst power average)	
				[dBm]	[mW]		[dBm]	[mW]
2402	-7.38	0.80	10.01	3.43	2.20	1.93	5.36	3.44
2440	-9.74	0.80	10.01	1.07	1.28	1.93	3.00	2.00
2480	-9.51	0.80	10.01	1.30	1.35	1.93	3.23	2.10

Sample Calculation:

Result (Time average) = Reading + Cable Loss (including the cable(s) customer supplied) + Attenuator Loss

Result (Burst power average) = Time average + Duty factor

### Burst rate confirmation

Test place : Ise EMC Lab. No.6 Measurement Room  
Report No. : 11774441H  
Date : July 13, 2017  
Temperature / Humidity : 24 deg. C / 62 % RH  
Engineer : Takafumi Noguchi  
Mode : Tx

#### 11b 5.5 Mbps

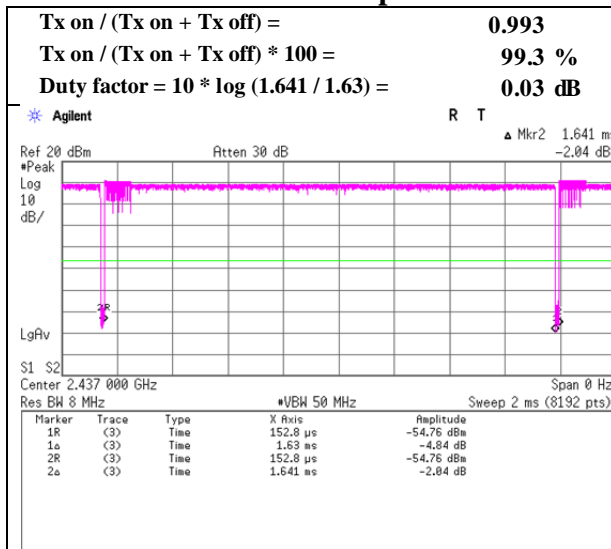

#### 11g 36 Mbps

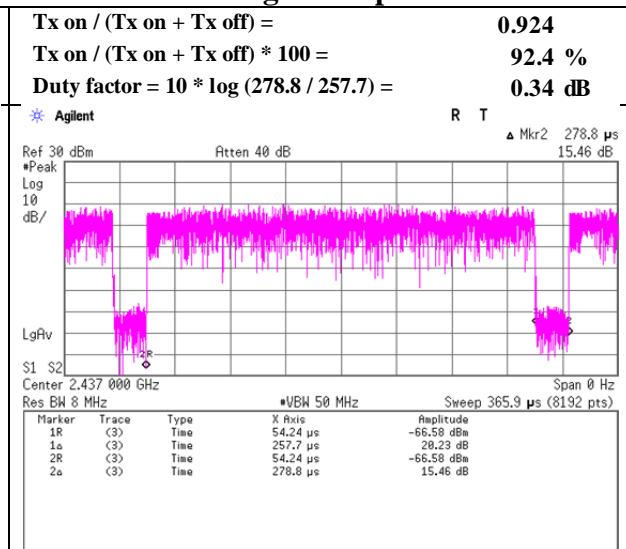

#### 11n-20 MCS 6

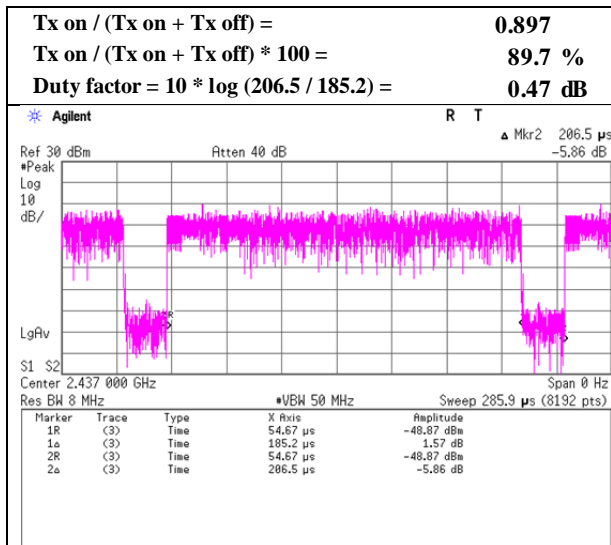

#### BT LE

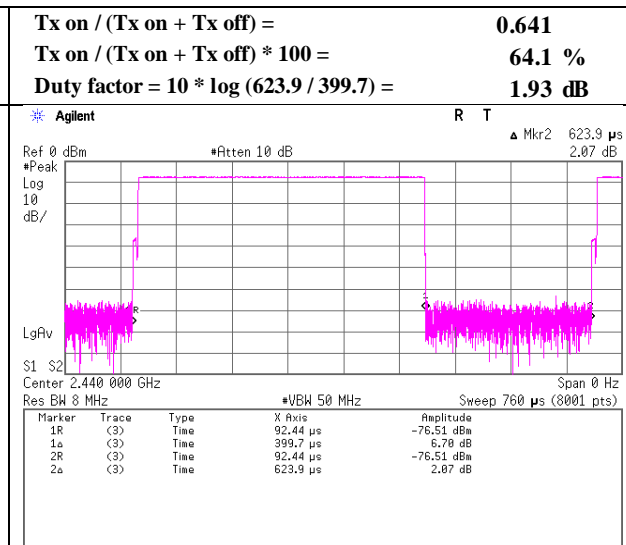

\* Since the burst rate is not different between the channels, the data has been obtained on the representative channel.

### Burst rate confirmation

Test place	Ise EMC Lab. No.6 Measurement Room
Report No.	11774441H
Date	July 13, 2017
Temperature / Humidity	24 deg. C / 62 % RH
Engineer	Takafumi Noguchi
Mode	Tx

#### 11b 1 Mbps

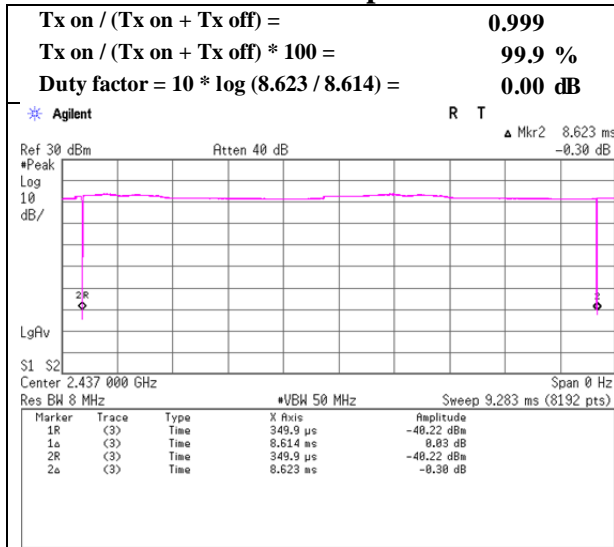

#### 11g 6 Mbps

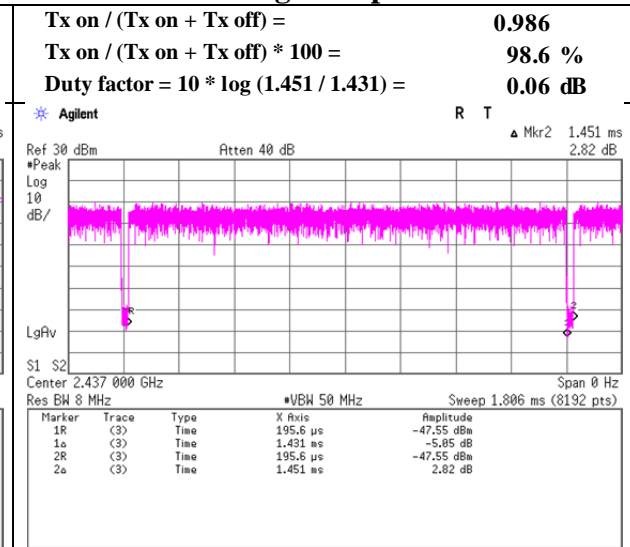

#### 11n-20 MCS 0

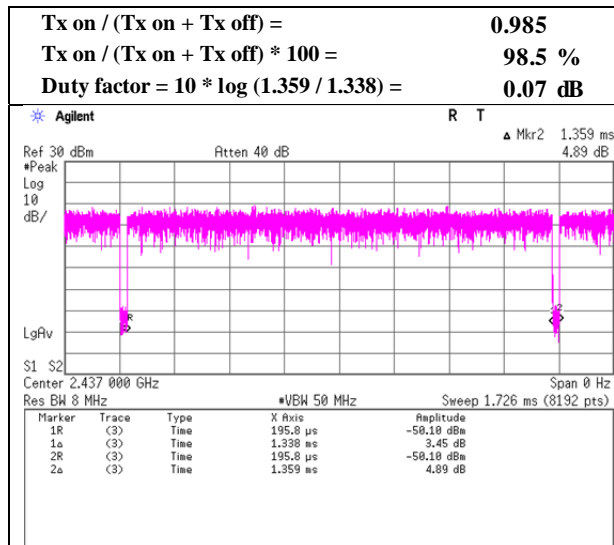

\* Since the burst rate is not different between the channels, the data has been obtained on the representative channel.

## Radiated Spurious Emission

Test place : Ise EMC Lab. No.2 Semi Anechoic Chamber  
Report No. : 11774441H  
Date : July 12, 2017      July 13, 2017      July 14, 2017  
Temperature / Humidity : 22 deg. C / 66 % RH    21 deg. C / 57 % RH    21 deg. C / 57 % RH  
Engineer : Tomoki Matsui      Takafumi Noguchi      Masafumi Niwa  
            (1 GHz -10 GHz)      (10 GHz -18 GHz)      (18 GHz -26.5 GHz)  
Mode : Tx 11b 2412 MHz

Polarity	Frequency [MHz]	Detector	Reading [dBuV]	Ant.Fac. [dB/m]	Loss [dB]	Gain [dB]	Duty Factor [dB]	Result [dBuV/m]	Limit [dBuV/m]	Margin [dB]	Remark
Hori	2390.000	PK	56.7	27.0	4.9	34.6	-	54.0	73.9	19.9	
Hori	4824.000	PK	42.3	31.3	7.6	33.8	-	47.4	73.9	26.5	Floor noise
Hori	7236.000	PK	41.7	35.7	8.4	33.9	-	51.9	73.9	22.0	Floor noise
Hori	9648.000	PK	42.0	38.2	9.3	34.5	-	55.0	73.9	18.9	Floor noise
Hori	2390.000	AV	46.6	27.0	4.9	34.6	-	43.9	53.9	10.0	
Hori	4824.000	AV	33.2	31.3	7.6	33.8	-	38.3	53.9	15.6	Floor noise
Hori	7236.000	AV	32.9	35.7	8.4	33.9	-	43.1	53.9	10.8	Floor noise
Hori	9648.000	AV	33.2	38.2	9.3	34.5	-	46.2	53.9	7.7	Floor noise
Vert	2390.000	PK	53.7	27.0	4.9	34.6	-	51.0	73.9	22.9	
Vert	4824.000	PK	42.3	31.3	7.6	33.8	-	47.4	73.9	26.5	Floor noise
Vert	7236.000	PK	41.7	35.7	8.4	33.9	-	51.9	73.9	22.0	Floor noise
Vert	9648.000	PK	42.0	38.2	9.3	34.5	-	55.0	73.9	18.9	Floor noise
Vert	2390.000	AV	42.9	27.0	4.9	34.6	-	40.2	53.9	13.7	
Vert	4824.000	AV	33.2	31.3	7.6	33.8	-	38.3	53.9	15.6	Floor noise
Vert	7236.000	AV	32.9	35.7	8.4	33.9	-	43.1	53.9	10.8	Floor noise
Vert	9648.000	AV	33.2	38.2	9.3	34.5	-	46.2	53.9	7.7	Floor noise

Result = Reading + Ant Factor + Loss (Cable+Attenuator+Filter+Distance factor(above 1 GHz)) - Gain(Amplifier)

\*Other frequency noises omitted in this report were not seen or had enough margin (more than 20 dB).

Distance factor:    1 GHz - 10 GHz    20log (3.75 m / 3.0 m) = 1.94 dB  
                          10 GHz - 26.5 GHz 20log (1.0 m / 3.0 m) = -9.5 dB

### 20dBc Data Sheet

Polarity	Frequency [MHz]	Detector	Reading [dBuV]	Ant Factor [dB/m]	Loss [dB]	Gain [dB]	Result [dBuV/m]	Limit [dBuV/m]	Margin [dB]	Remark
Hori	2412.000	PK	108.6	27.0	5.1	34.6	106.1	-	-	Carrier
Hori	2398.504	PK	70.4	27.0	5.0	34.6	67.8	86.1	18.3	
Hori	2400.000	PK	62.9	27.0	5.0	34.6	60.3	86.1	25.8	
Vert	2412.000	PK	106.1	27.0	5.1	34.6	103.6	-	-	Carrier
Vert	2398.504	PK	67.1	27.0	5.0	34.6	64.5	83.6	19.1	
Vert	2400.000	PK	59.9	27.0	5.0	34.6	57.3	83.6	26.3	

Result = Reading + Ant Factor + Loss (Cable+Attenuator+Filter+Distance factor(above 1 GHz)) - Gain(Amplifier)

## Radiated Spurious Emission (Reference Plot for band-edge)

Test place	Ise EMC Lab. No.2 Semi Anechoic Chamber
Report No.	11774441H
Date	July 12, 2017
Temperature / Humidity	22 deg. C / 66 % RH
Engineer	Tomoki Matsui
	(1 GHz -10 GHz)
Mode	Tx 11b 2412 MHz

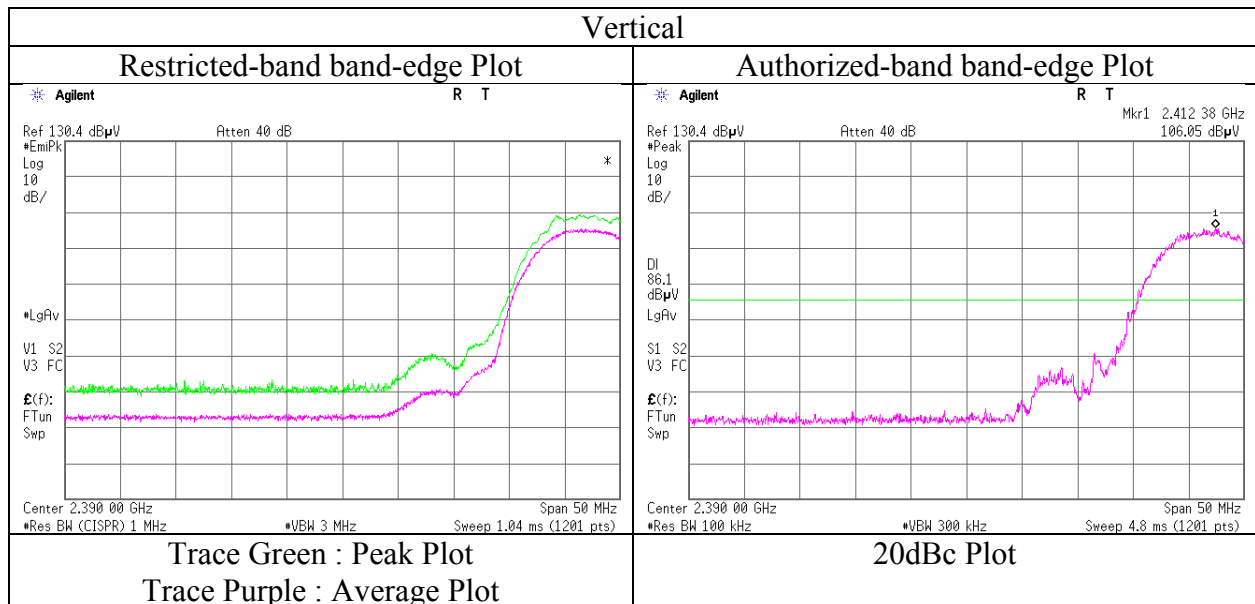
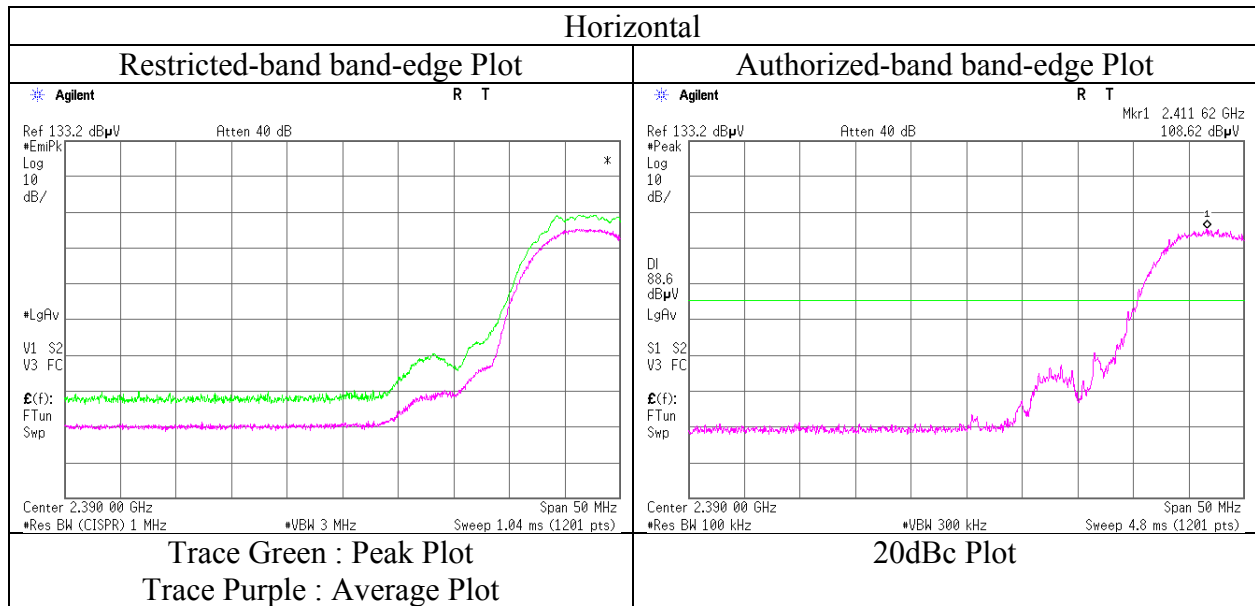

\* Final result of restricted band edge was shown in tabular data.

**UL Japan, Inc.**

**Ise EMC Lab.**

4383-326 Asama-cho, Ise-shi, Mie-ken 516-0021 JAPAN

Telephone : +81 596 24 8999

Facsimile : +81 596 24 8124

## Radiated Spurious Emission

Test place	Ise EMC Lab. No.2 Semi Anechoic Chamber		
Report No.	11774441H		
Date	July 12, 2017	July 13, 2017	July 14, 2017
Temperature / Humidity	22 deg. C / 66 % RH	21 deg. C / 57 % RH	21 deg. C / 57 % RH
Engineer	Tomoki Matsui	Takafumi Noguchi	Masafumi Niwa
	(1 GHz -10 GHz)	(10 GHz -18 GHz)	(18 GHz -26.5 GHz)
Mode	Tx 11b 2437 MHz		

Polarity	Frequency [MHz]	Detector	Reading [dBuV]	Ant.Fac. [dB/m]	Loss [dB]	Gain [dB]	Duty Factor [dB]	Result [dBuV/m]	Limit [dBuV/m]	Margin [dB]	Remark
Hori	4874.000	PK	43.1	31.4	7.6	33.8	-	48.3	73.9	25.6	Floor noise
Hori	7311.000	PK	43.6	35.7	8.5	33.9	-	53.9	73.9	20.0	Floor noise
Hori	9748.000	PK	42.9	38.2	9.2	34.5	-	55.8	73.9	18.1	Floor noise
Hori	4874.000	AV	34.2	31.4	7.6	33.8	-	39.4	53.9	14.5	Floor noise
Hori	7311.000	AV	34.2	35.7	8.5	33.9	-	44.5	53.9	9.4	Floor noise
Hori	9748.000	AV	34.3	38.2	9.2	34.5	-	47.2	53.9	6.7	Floor noise
Vert	4874.000	PK	43.1	31.4	7.6	33.8	-	48.3	73.9	25.6	Floor noise
Vert	7311.000	PK	43.6	35.7	8.5	33.9	-	53.9	73.9	20.0	Floor noise
Vert	9748.000	PK	42.9	38.2	9.2	34.5	-	55.8	73.9	18.1	Floor noise
Vert	4874.000	AV	34.2	31.4	7.6	33.8	-	39.4	53.9	14.5	Floor noise
Vert	7311.000	AV	34.2	35.7	8.5	33.9	-	44.5	53.9	9.4	Floor noise
Vert	9748.000	AV	34.3	38.2	9.2	34.5	-	47.2	53.9	6.7	Floor noise

Result = Reading + Ant Factor + Loss (Cable+Attenuator+Filter+Distance factor(above 1 GHz)) - Gain(Amplifier)

\*Other frequency noises omitted in this report were not seen or had enough margin (more than 20 dB).

Distance factor:    1 GHz - 10 GHz    20log (3.75 m / 3.0 m) = 1.94 dB  
                          10 GHz - 26.5 GHz 20log (1.0 m / 3.0 m) = -9.5 dB



## Radiated Spurious Emission

Test place	Ise EMC Lab. No.2 Semi Anechoic Chamber		
Report No.	11774441H		
Date	July 12, 2017	July 13, 2017	July 14, 2017
Temperature / Humidity	22 deg. C / 66 % RH	21 deg. C / 57 % RH	21 deg. C / 57 % RH
Engineer	Tomoki Matsui	Takafumi Noguchi	Masafumi Niwa
	(1 GHz -10 GHz)	(10 GHz -18 GHz)	(18 GHz -26.5 GHz)
Mode	Tx 11b 2462 MHz		

Polarity	Frequency [MHz]	Detector	Reading [dBuV]	Ant.Fac. [dB/m]	Loss [dB]	Gain [dB]	Duty Factor [dB]	Result [dBuV/m]	Limit [dBuV/m]	Margin [dB]	Remark
Hori	2483.500	PK	54.6	27.0	5.1	34.6	-	52.1	73.9	21.8	
Hori	4924.000	PK	42.3	31.5	7.5	33.8	-	47.5	73.9	26.4	Floor noise
Hori	7386.000	PK	42.2	35.8	8.5	34.0	-	52.5	73.9	21.4	Floor noise
Hori	9848.000	PK	41.8	38.2	9.2	34.5	-	54.7	73.9	19.2	Floor noise
Hori	2483.500	AV	44.0	27.0	5.1	34.6	-	41.5	53.9	12.4	
Hori	4924.000	AV	33.6	31.5	7.5	33.8	-	38.8	53.9	15.1	Floor noise
Hori	7386.000	AV	33.3	35.8	8.5	34.0	-	43.6	53.9	10.3	Floor noise
Hori	9848.000	AV	33.6	38.2	9.2	34.5	-	46.5	53.9	7.4	Floor noise
Vert	2483.500	PK	51.9	27.0	5.1	34.6	-	49.4	73.9	24.5	
Vert	4924.000	PK	42.3	31.5	7.5	33.8	-	47.5	73.9	26.4	Floor noise
Vert	7386.000	PK	42.2	35.8	8.5	34.0	-	52.5	73.9	21.4	Floor noise
Vert	9848.000	PK	41.8	38.2	9.2	34.5	-	54.7	73.9	19.2	Floor noise
Vert	2483.500	AV	40.6	27.0	5.1	34.6	-	38.1	53.9	15.8	
Vert	4924.000	AV	33.6	31.5	7.5	33.8	-	38.8	53.9	15.1	Floor noise
Vert	7386.000	AV	33.3	35.8	8.5	34.0	-	43.6	53.9	10.3	Floor noise
Vert	9848.000	AV	33.6	38.2	9.2	34.5	-	46.5	53.9	7.4	Floor noise

Result = Reading + Ant Factor + Loss (Cable+Attenuator+Filter+Distance factor(above 1 GHz)) - Gain(Amplifier)

\*Other frequency noises omitted in this report were not seen or had enough margin (more than 20 dB).

Distance factor:     1 GHz - 10 GHz    20log (3.75 m / 3.0 m) = 1.94 dB  
                          10 GHz - 26.5 GHz 20log (1.0 m / 3.0 m) = -9.5 dB

**Radiated Spurious Emission**  
**(Reference Plot for band-edge)**

Test place	Ise EMC Lab. No.2 Semi Anechoic Chamber
Report No.	11774441H
Date	July 12, 2017
Temperature / Humidity	22 deg. C / 66 % RH
Engineer	Tomoki Matsui
	(1 GHz -10 GHz)
Mode	Tx 11b 2462 MHz

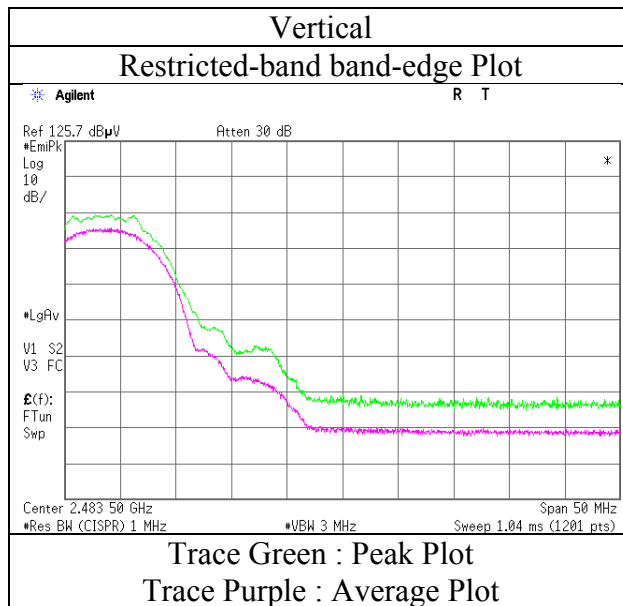
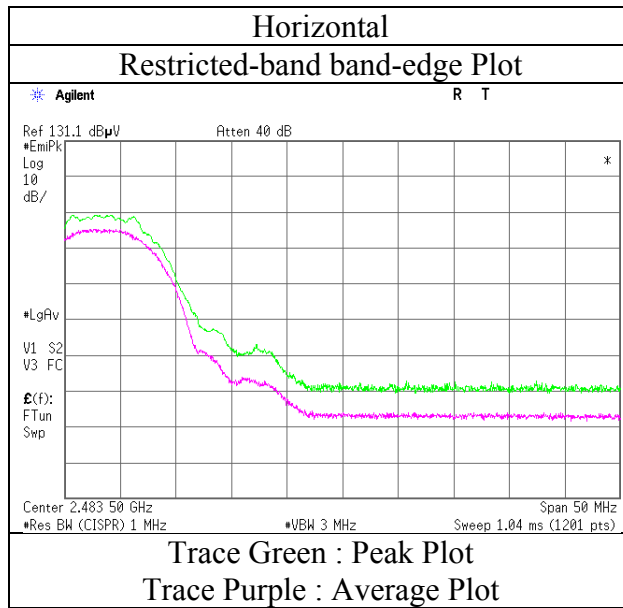

\* Final result of restricted band edge was shown in tabular data.



## Radiated Spurious Emission (Reference Plot for band-edge)

Test place	Ise EMC Lab. No.2 Semi Anechoic Chamber
Report No.	11774441H
Date	July 13, 2017
Temperature / Humidity	21 deg. C / 57 % RH
Engineer	Takafumi Noguchi
	(1 GHz -10 GHz)
Mode	Tx 11g 2412 MHz

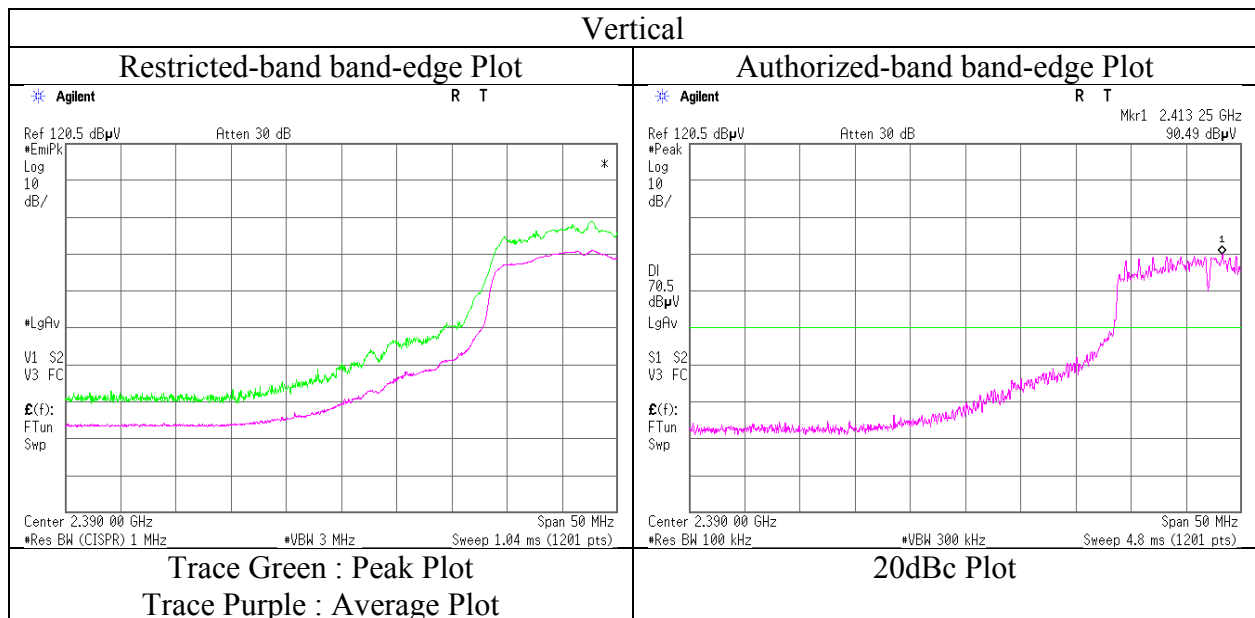
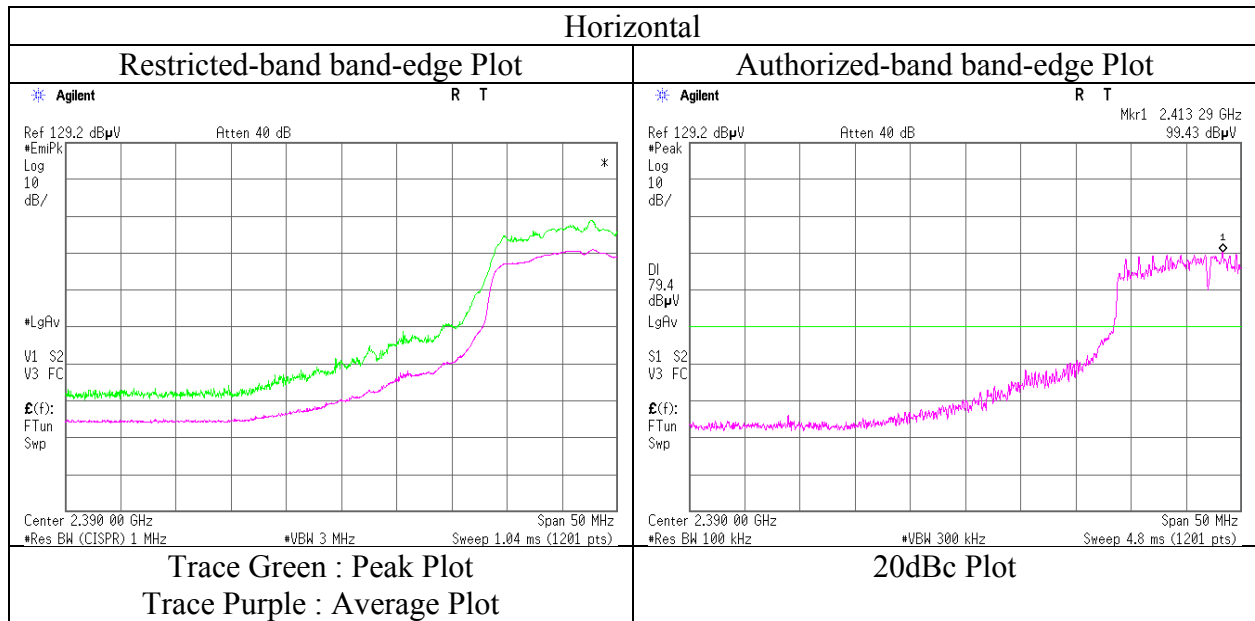

\* Final result of restricted band edge was shown in tabular data.

## Radiated Spurious Emission

Test place : Ise EMC Lab. No.2 Semi Anechoic Chamber  
Report No. : 11774441H  
Date : July 13, 2017                      July 14, 2017  
Temperature / Humidity : 21 deg. C / 57 % RH    21 deg. C / 57 % RH  
Engineer : Takafumi Noguchi            Masafumi Niwa  
                  (1 GHz -18 GHz)            (18 GHz -26.5 GHz)  
Mode : Tx 11g 2437 MHz

Polarity	Frequency [MHz]	Detector	Reading [dBuV]	Ant.Fac. [dB/m]	Loss [dB]	Gain [dB]	Duty Factor [dB]	Result [dBuV/m]	Limit [dBuV/m]	Margin [dB]	Remark
Hori	4874.000	PK	42.8	31.4	7.6	33.8	-	48.0	73.9	25.9	Floor noise
Hori	7311.000	PK	43.0	35.7	8.5	33.9	-	53.3	73.9	20.6	Floor noise
Hori	9748.000	PK	42.7	38.2	9.2	34.5	-	55.6	73.9	18.3	Floor noise
Hori	4874.000	AV	32.4	31.4	7.6	33.8	-	37.6	53.9	16.3	Floor noise
Hori	7311.000	AV	33.7	35.7	8.5	33.9	-	44.0	53.9	9.9	Floor noise
Hori	9748.000	AV	33.6	38.2	9.2	34.5	-	46.5	53.9	7.4	Floor noise
Vert	4874.000	PK	43.0	31.4	7.6	33.8	-	48.2	73.9	25.7	Floor noise
Vert	7311.000	PK	43.4	35.7	8.5	33.9	-	53.7	73.9	20.2	Floor noise
Vert	9748.000	PK	47.2	38.2	9.2	34.5	-	60.1	73.9	13.8	Floor noise
Vert	4874.000	AV	33.7	31.4	7.6	33.8	-	38.9	53.9	15.0	Floor noise
Vert	7311.000	AV	33.8	35.7	8.5	33.9	-	44.1	53.9	9.8	Floor noise
Vert	9748.000	AV	33.7	38.2	9.2	34.5	-	46.6	53.9	7.3	Floor noise

Result = Reading + Ant Factor + Loss (Cable+Attenuator+Filter+Distance factor(above 1 GHz)) - Gain(Amplifier)

\*Other frequency noises omitted in this report were not seen or had enough margin (more than 20 dB).

Distance factor:    1 GHz - 10 GHz    20log (3.75 m / 3.0 m) = 1.94 dB  
                          10 GHz - 26.5 GHz 20log (1.0 m / 3.0 m) = -9.5 dB



**Radiated Spurious Emission**  
**(Reference Plot for band-edge)**

Test place Ise EMC Lab. No.2 Semi Anechoic Chamber  
Report No. 11774441H  
Date July 13, 2017  
Temperature / Humidity 21 deg. C / 57 % RH  
Engineer Takafumi Noguchi  
(1 GHz -10 GHz)  
Mode Tx 11g 2462 MHz

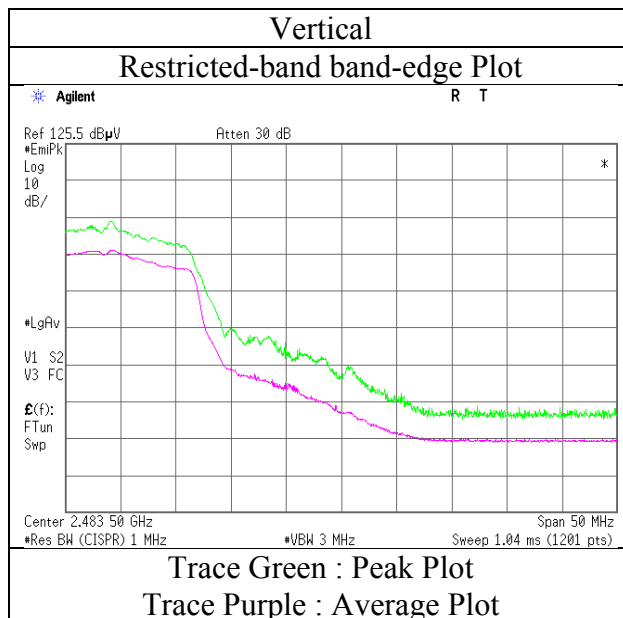
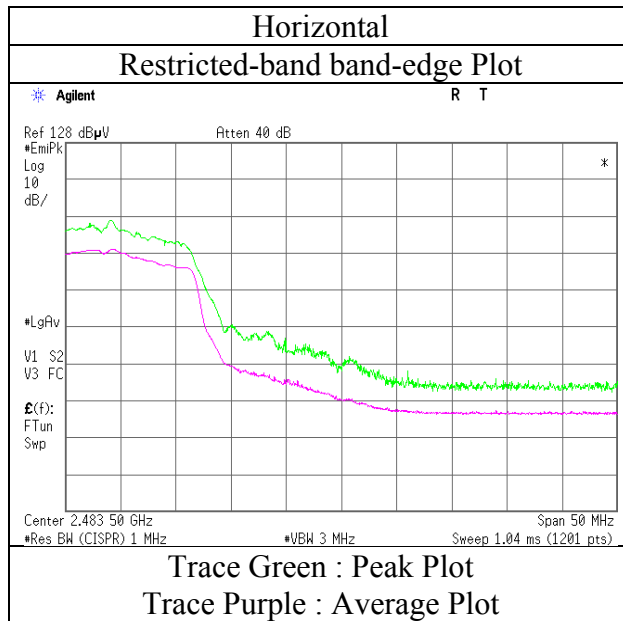

\* Final result of restricted band edge was shown in tabular data.

## Radiated Spurious Emission

Test place	Ise EMC Lab. No.2 Semi Anechoic Chamber		
Report No.	11774441H		
Date	July 12, 2017	July 13, 2017	July 14, 2017
Temperature / Humidity	22 deg. C / 66 % RH	21 deg. C / 57 % RH	21 deg. C / 57 % RH
Engineer	Tomoki Matsui (1 GHz -10 GHz)	Takafumi Noguchi (10 GHz -18 GHz)	Masafumi Niwa (18 GHz -26.5 GHz)
Mode	Tx 11n-20 2412 MHz		

Polarity	Frequency [MHz]	Detector	Reading [dBuV]	Ant.Fac. [dB/m]	Loss [dB]	Gain [dB]	Duty Factor [dB]	Result [dBuV/m]	Limit [dBuV/m]	Margin [dB]	Remark
Hori	2390.000	PK	69.1	27.0	4.9	34.6	-	66.4	73.9	7.5	
Hori	4824.000	PK	42.3	31.3	7.6	33.8	-	47.4	73.9	26.5	Floor noise
Hori	7236.000	PK	41.7	35.7	8.4	33.9	-	51.9	73.9	22.0	Floor noise
Hori	9648.000	PK	42.0	38.2	9.3	34.5	-	55.0	73.9	18.9	Floor noise
Hori	2390.000	AV	54.2	27.0	4.9	34.6	0.5	52.0	53.9	1.9	*1)
Hori	4824.000	AV	33.2	31.3	7.6	33.8	-	38.3	53.9	15.6	Floor noise
Hori	7236.000	AV	32.9	35.7	8.4	33.9	-	43.1	53.9	10.8	Floor noise
Hori	9648.000	AV	33.2	38.2	9.3	34.5	-	46.2	53.9	7.7	Floor noise
Vert	2390.000	PK	68.5	27.0	4.9	34.6	-	65.8	73.9	8.1	
Vert	4824.000	PK	42.3	31.3	7.6	33.8	-	47.4	73.9	26.5	Floor noise
Vert	7236.000	PK	41.7	35.7	8.4	33.9	-	51.9	73.9	22.0	Floor noise
Vert	9648.000	PK	42.0	38.2	9.3	34.5	-	55.0	73.9	18.9	Floor noise
Vert	2390.000	AV	54.2	27.0	4.9	34.6	0.5	52.0	53.9	1.9	*1)
Vert	4824.000	AV	33.2	31.3	7.6	33.8	-	38.3	53.9	15.6	Floor noise
Vert	7236.000	AV	32.9	35.7	8.4	33.9	-	43.1	53.9	10.8	Floor noise
Vert	9648.000	AV	33.2	38.2	9.3	34.5	-	46.2	53.9	7.7	Floor noise

Result = Reading + Ant Factor + Loss (Cable+Attenuator+Filter+Distance factor(above 1 GHz)) - Gain(Amplifier) + Duty factor

\*Other frequency noises omitted in this report were not seen or had enough margin (more than 20 dB).

Distance factor:     1 GHz - 10 GHz    20log (3.75 m / 3.0 m) = 1.94 dB  
                          10 GHz - 26.5 GHz 20log (1.0 m / 3.0 m) = -9.5 dB

\*1) Not Out of Band emission(Leakage Power)

### 20dBc Data Sheet

Polarity	Frequency [MHz]	Detector	Reading [dBuV]	Ant Factor [dB/m]	Loss [dB]	Gain [dB]	Result [dBuV/m]	Limit [dBuV/m]	Margin [dB]	Remark
Hori	2412.000	PK	97.5	27.0	5.1	34.6	95.0	-	-	Carrier
Hori	2400.000	PK	65.9	27.0	5.0	34.6	63.3	75.0	11.7	
Vert	2412.000	PK	94.8	27.0	5.1	34.6	92.3	-	-	Carrier
Vert	2400.000	PK	64.5	27.0	5.0	34.6	61.9	72.3	10.4	

Result = Reading + Ant Factor + Loss (Cable+Attenuator+Filter+Distance factor(above 1 GHz)) - Gain(Amplifier)



## Radiated Spurious Emission (Reference Plot for band-edge)

Test place	Ise EMC Lab. No.2 Semi Anechoic Chamber
Report No.	11774441H
Date	July 12, 2017
Temperature / Humidity	22 deg. C / 66 % RH
Engineer	Tomoki Matsui
	(1 GHz -10 GHz)
Mode	Tx 11n-20 2412 MHz

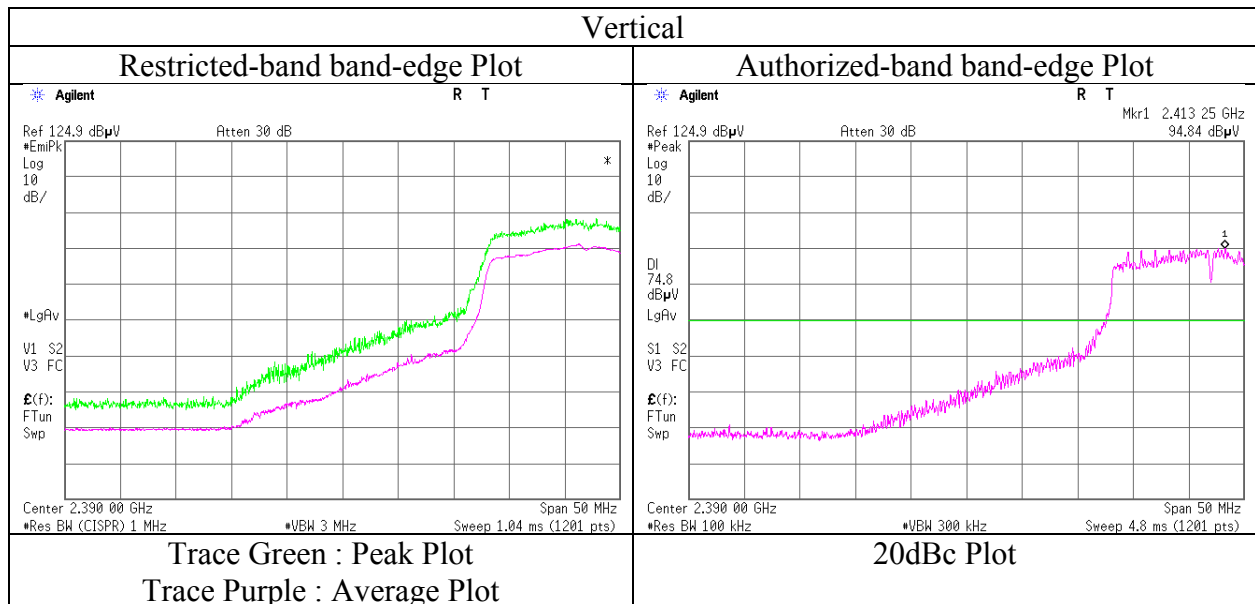
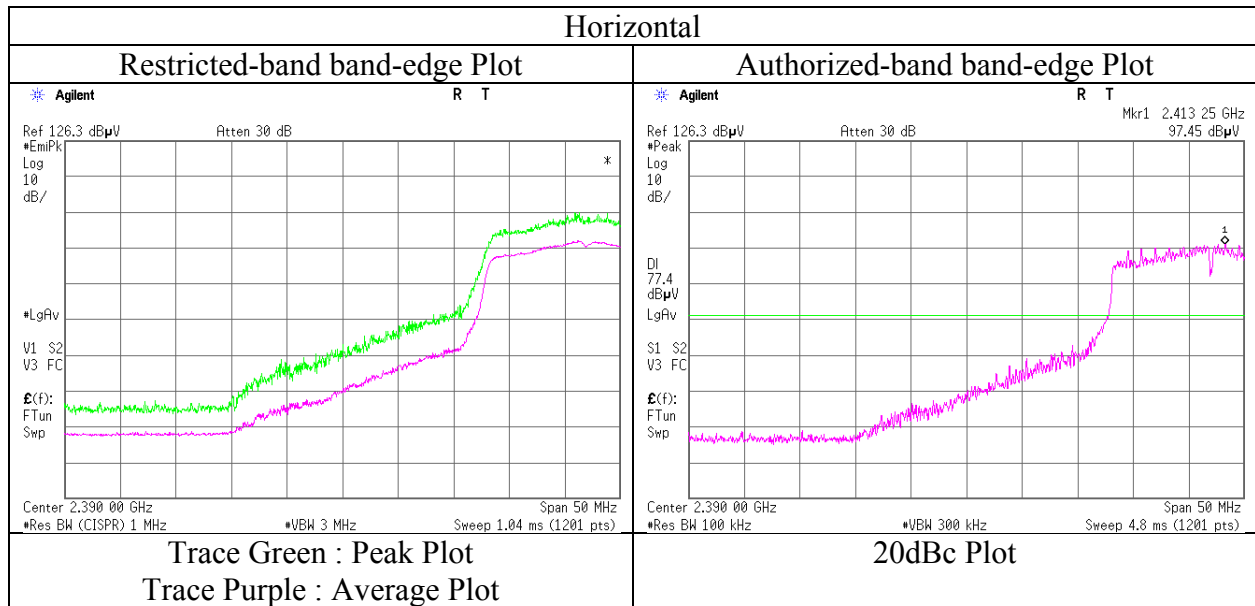

\* Final result of restricted band edge was shown in tabular data.

**UL Japan, Inc.**

**Ise EMC Lab.**

4383-326 Asama-cho, Ise-shi, Mie-ken 516-0021 JAPAN

Telephone : +81 596 24 8999

Facsimile : +81 596 24 8124

## Radiated Spurious Emission

Test place	Ise EMC Lab. No.2 Semi Anechoic Chamber		
Report No.	11774441H		
Date	July 12, 2017	July 13, 2017	July 14, 2017
Temperature / Humidity	22 deg. C / 66 % RH	21 deg. C / 57 % RH	21 deg. C / 57 % RH
Engineer	Tomoki Matsui (1 GHz -10 GHz)	Takafumi Noguchi (10 GHz -18 GHz)	Masafumi Niwa (18 GHz -26.5 GHz)
Mode	Tx 11n-20 2437 MHz		

Polarity	Frequency [MHz]	Detector	Reading [dBuV]	Ant.Fac. [dB/m]	Loss [dB]	Gain [dB]	Duty Factor [dB]	Result [dBuV/m]	Limit [dBuV/m]	Margin [dB]	Remark
Hori	4874.000	PK	43.1	31.4	7.6	33.8	-	48.3	73.9	25.6	Floor noise
Hori	7311.000	PK	43.6	35.7	8.5	33.9	-	53.9	73.9	20.0	Floor noise
Hori	9748.000	PK	42.9	38.2	9.2	34.5	-	55.8	73.9	18.1	Floor noise
Hori	4874.000	AV	34.2	31.4	7.6	33.8	-	39.4	53.9	14.5	Floor noise
Hori	7311.000	AV	34.2	35.7	8.5	33.9	-	44.5	53.9	9.4	Floor noise
Hori	9748.000	AV	34.3	38.2	9.2	34.5	-	47.2	53.9	6.7	Floor noise
Vert	4874.000	PK	43.1	31.4	7.6	33.8	-	48.3	73.9	25.6	Floor noise
Vert	7311.000	PK	43.6	35.7	8.5	33.9	-	53.9	73.9	20.0	Floor noise
Vert	9748.000	PK	42.9	38.2	9.2	34.5	-	55.8	73.9	18.1	Floor noise
Vert	4874.000	AV	34.2	31.4	7.6	33.8	-	39.4	53.9	14.5	Floor noise
Vert	7311.000	AV	34.2	35.7	8.5	33.9	-	44.5	53.9	9.4	Floor noise
Vert	9748.000	AV	34.3	38.2	9.2	34.5	-	47.2	53.9	6.7	Floor noise

Result = Reading + Ant Factor + Loss (Cable+Attenuator+Filter+Distance factor(above 1 GHz)) - Gain(Amplifier)

\*Other frequency noises omitted in this report were not seen or had enough margin (more than 20 dB).

Distance factor:     1 GHz - 10 GHz    20log(3.75 m / 3.0 m) = 1.94 dB  
                          10 GHz - 26.5 GHz 20log(1.0 m / 3.0 m) = -9.5 dB

## Radiated Spurious Emission

Test place : Ise EMC Lab. No.2 Semi Anechoic Chamber  
Report No. : 11774441H  
Date : July 13, 2017      July 14, 2017      July 15, 2017  
Temperature / Humidity : 21 deg. C / 57 % RH    21 deg. C / 57 % RH    23 deg. C / 65 % RH  
Engineer : Takafumi Noguchi    Masafumi Niwa    Takumi Shimada  
(1 GHz -18 GHz)    (18 GHz -26.5 GHz)    (30 MHz -1000 MHz)  
Mode : Tx 11n-20 2462 MHz

Polarity	Frequency [MHz]	Detector	Reading [dBuV]	Ant.Fac. [dB/m]	Loss [dB]	Gain [dB]	Duty Factor [dB]	Result [dBuV/m]	Limit [dBuV/m]	Margin [dB]	Remark
Hori	40.000	QP	24.6	14.1	6.8	28.2	-	17.3	40.0	22.7	Floor noise
Hori	100.000	QP	25.7	10.1	7.4	28.0	-	15.2	43.5	28.3	Floor noise
Hori	150.000	QP	23.8	14.8	7.8	27.8	-	18.6	43.5	24.9	Floor noise
Hori	300.000	QP	23.0	13.4	8.8	27.2	-	18.0	46.0	28.0	Floor noise
Hori	500.000	QP	23.7	17.7	9.8	28.1	-	23.1	46.0	22.9	Floor noise
Hori	700.000	QP	22.9	19.8	10.5	27.6	-	25.6	46.0	20.4	Floor noise
Hori	2483.500	PK	69.2	27.0	5.1	34.6	-	66.7	73.9	7.2	
Hori	4924.000	PK	42.3	31.5	7.5	33.8	-	47.5	73.9	26.4	Floor noise
Hori	7386.000	PK	42.2	35.8	8.5	34.0	-	52.5	73.9	21.4	Floor noise
Hori	9848.000	PK	41.8	38.2	9.2	34.5	-	54.7	73.9	19.2	Floor noise
Hori	2483.500	AV	53.5	27.0	5.1	34.6	0.5	51.5	53.9	2.4	*1)
Hori	4924.000	AV	33.6	31.5	7.5	33.8	-	38.8	53.9	15.1	Floor noise
Hori	7386.000	AV	33.3	35.8	8.5	34.0	-	43.6	53.9	10.3	Floor noise
Hori	9848.000	AV	33.6	38.2	9.2	34.5	-	46.5	53.9	7.4	Floor noise
Vert	40.000	QP	24.6	14.1	6.8	28.2	-	17.3	40.0	22.7	Floor noise
Vert	100.000	QP	24.4	10.1	7.4	28.0	-	13.9	43.5	29.6	Floor noise
Vert	150.000	QP	23.9	14.8	7.8	27.8	-	18.7	43.5	24.8	Floor noise
Vert	300.000	QP	23.1	13.4	8.8	27.2	-	18.1	46.0	27.9	Floor noise
Vert	500.000	QP	23.6	17.7	9.8	28.1	-	23.0	46.0	23.0	Floor noise
Vert	700.000	QP	22.9	19.8	10.5	27.6	-	25.6	46.0	20.4	Floor noise
Vert	2483.500	PK	65.9	27.0	5.1	34.6	-	63.4	73.9	10.5	
Vert	4924.000	PK	42.3	31.5	7.5	33.8	-	47.5	73.9	26.4	Floor noise
Vert	7386.000	PK	42.2	35.8	8.5	34.0	-	52.5	73.9	21.4	Floor noise
Vert	9848.000	PK	41.8	38.2	9.2	34.5	-	54.7	73.9	19.2	Floor noise
Vert	2483.500	AV	51.3	27.0	5.1	34.6	0.5	49.3	53.9	4.6	*1)
Vert	4924.000	AV	33.6	31.5	7.5	33.8	-	38.8	53.9	15.1	Floor noise
Vert	7386.000	AV	33.3	35.8	8.5	34.0	-	43.6	53.9	10.3	Floor noise
Vert	9848.000	AV	33.6	38.2	9.2	34.5	-	46.5	53.9	7.4	Floor noise

Result = Reading + Ant Factor + Loss (Cable+Attenuator+Filter+Distance factor(above 1 GHz)) - Gain(Amplifier) + Duty factor

\*Other frequency noises omitted in this report were not seen or had enough margin (more than 20 dB).

Distance factor:      1 GHz - 10 GHz    20log(3.75 m / 3.0 m) = 1.94 dB  
                              10 GHz - 26.5 GHz    20log(1.0 m / 3.0 m) = -9.5 dB

\*1) Not Out of Band emission(Leakage Power)

**Radiated Spurious Emission**  
**(Reference Plot for band-edge)**

Test place : Ise EMC Lab. No.2 Semi Anechoic Chamber  
Report No. : 11774441H  
Date : July 13, 2017  
Temperature / Humidity : 21 deg. C / 57 % RH  
Engineer : Takafumi Noguchi  
(1 GHz -10 GHz)  
Mode : Tx 11n-20 2462 MHz

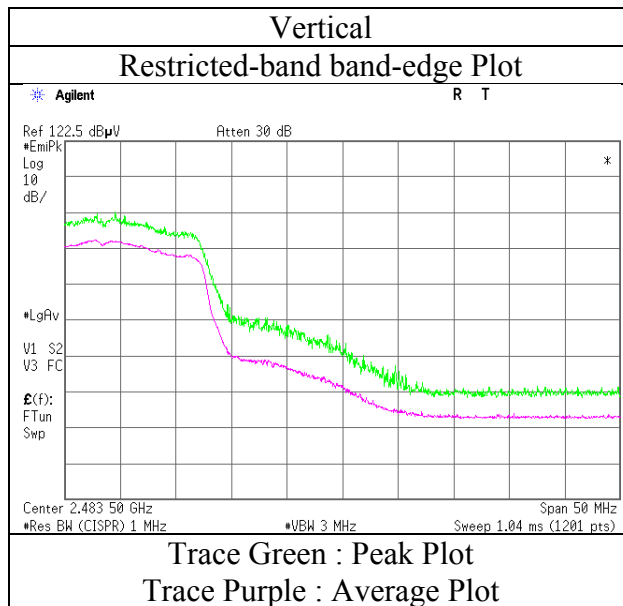
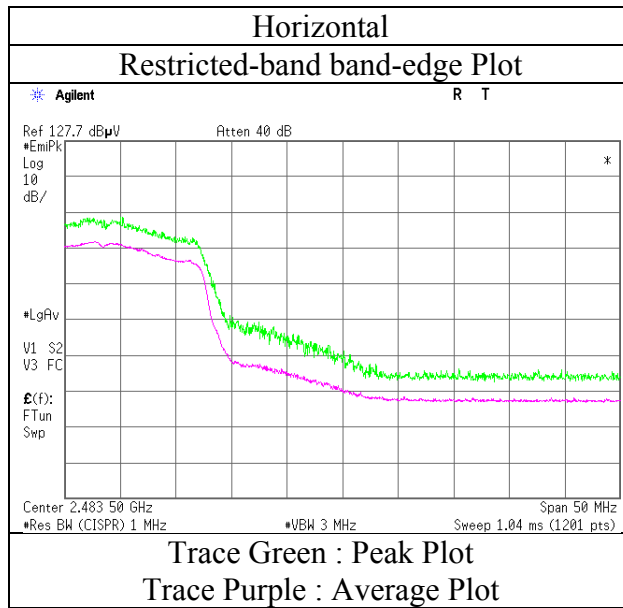

\* Final result of restricted band edge was shown in tabular data.

## Radiated Spurious Emission (Plot data, Worst case)

Test place	Ise EMC Lab. No.2 Semi Anechoic Chamber		
Report No.	11774441H		
Date	July 13, 2017	July 14, 2017	July 15, 2017
Temperature / Humidity	21 deg. C / 57 % RH	21 deg. C / 57 % RH	23 deg. C / 65 % RH
Engineer	Takafumi Noguchi (1 GHz -18 GHz)	Masafumi Niwa (18 GHz -26.5 GHz)	Takumi Shimada (30 MHz -1000 MHz)
Mode	Tx 11n-20 2462 MHz		

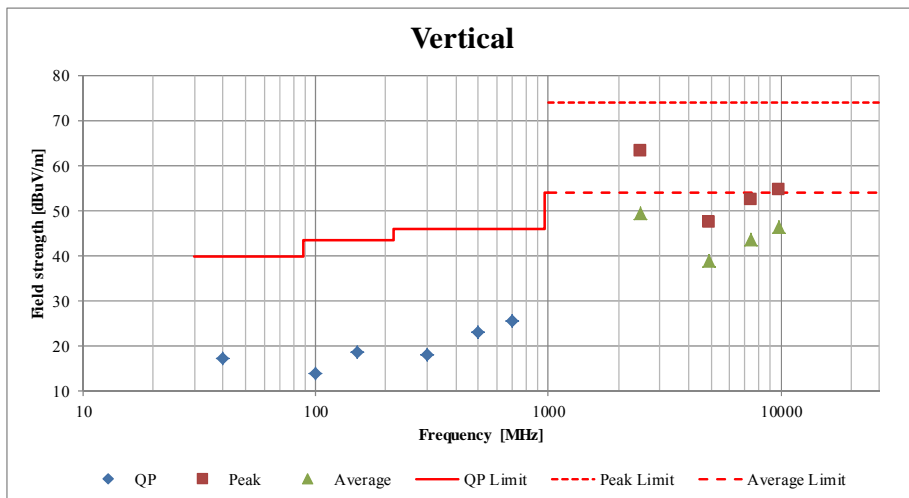
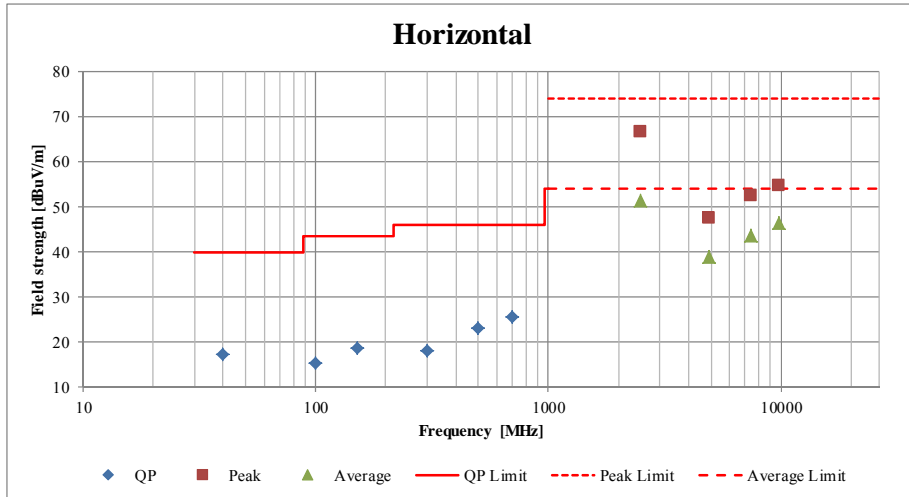

\*These plots data contains sufficient number to show the trend of characteristic features for EUT.

## Radiated Spurious Emission

Test place : Ise EMC Lab. No.2 Semi Anechoic Chamber  
Report No. : 11774441H  
Date : July 12, 2017      July 14, 2017      July 15, 2017  
Temperature / Humidity : 22 deg. C / 66 % RH    21 deg. C / 57 % RH    23 deg. C / 65 % RH  
Engineer : Tomoki Matsui      Masafumi Niwa      Takumi Shimada  
(1 GHz -10 GHz)      (10 GHz -26.5 GHz)    (30 MHz -1000 MHz)  
Mode : Tx BT LE 2402 MHz

Polarity	Frequency [MHz]	Detector	Reading [dBuV]	Ant.Fac. [dB/m]	Loss [dB]	Gain [dB]	Duty Factor [dB]	Result [dBuV/m]	Limit [dBuV/m]	Margin [dB]	Remark
Hori	40.000	QP	24.6	14.1	6.8	28.2	-	17.3	40.0	22.7	Floor noise
Hori	100.000	QP	25.8	10.1	7.4	28.0	-	15.3	43.5	28.2	Floor noise
Hori	150.000	QP	23.8	14.8	7.8	27.8	-	18.6	43.5	24.9	Floor noise
Hori	300.000	QP	23.2	13.4	8.8	27.2	-	18.2	46.0	27.8	Floor noise
Hori	500.000	QP	23.9	17.7	9.8	28.1	-	23.3	46.0	22.7	Floor noise
Hori	700.000	QP	22.8	19.8	10.5	27.6	-	25.5	46.0	20.5	Floor noise
Hori	2390.000	PK	44.2	27.0	4.9	34.6	-	41.5	73.9	32.4	
Hori	4804.000	PK	42.6	31.3	7.6	33.8	-	47.7	73.9	26.2	Floor noise
Hori	7206.000	PK	41.6	35.6	8.4	33.9	-	51.7	73.9	22.2	Floor noise
Hori	9608.000	PK	43.4	38.2	9.3	34.5	-	56.4	73.9	17.5	Floor noise
Hori	2390.000	AV	35.2	27.0	4.9	34.6	1.9	34.4	53.9	19.5	*1)
Hori	4804.000	AV	33.6	31.3	7.6	33.8	-	38.7	53.9	15.2	Floor noise
Hori	7206.000	AV	33.9	35.6	8.4	33.9	-	44.0	53.9	9.9	Floor noise
Hori	9608.000	AV	33.8	38.2	9.3	34.5	-	46.8	53.9	7.1	Floor noise
Vert	40.000	QP	24.7	14.1	6.8	28.2	-	17.4	40.0	22.6	Floor noise
Vert	100.000	QP	24.8	10.1	7.4	28.0	-	14.3	43.5	29.2	Floor noise
Vert	150.000	QP	23.8	14.8	7.8	27.8	-	18.6	43.5	24.9	Floor noise
Vert	300.000	QP	23.1	13.4	8.8	27.2	-	18.1	46.0	27.9	Floor noise
Vert	500.000	QP	23.8	17.7	9.8	28.1	-	23.2	46.0	22.8	Floor noise
Vert	700.000	QP	22.9	19.8	10.5	27.6	-	25.6	46.0	20.4	Floor noise
Vert	2390.000	PK	44.3	27.0	4.9	34.6	-	41.6	73.9	32.3	
Vert	4804.000	PK	42.6	31.3	7.6	33.8	-	47.7	73.9	26.2	Floor noise
Vert	7206.000	PK	41.6	35.6	8.4	33.9	-	51.7	73.9	22.2	Floor noise
Vert	9608.000	PK	43.4	38.2	9.3	34.5	-	56.4	73.9	17.5	Floor noise
Vert	2390.000	AV	35.3	27.0	4.9	34.6	1.9	34.5	53.9	19.4	*1)
Vert	4804.000	AV	33.6	31.3	7.6	33.8	-	38.7	53.9	15.2	Floor noise
Vert	7206.000	AV	33.9	35.6	8.4	33.9	-	44.0	53.9	9.9	Floor noise
Vert	9608.000	AV	33.8	38.2	9.3	34.5	-	46.8	53.9	7.1	Floor noise

Result = Reading + Ant Factor + Loss (Cable+Attenuator+Filter+Distance factor(above 1 GHz)) - Gain(Amplifier) + Duty factor

\*Other frequency noises omitted in this report were not seen or had enough margin (more than 20 dB).

Distance factor:      1 GHz - 10 GHz      20log(3.75 m / 3.0 m) = 1.94 dB  
                                 10 GHz - 26.5 GHz      20log(1.0 m / 3.0 m) = -9.5 dB

\*1) Not Out of Band emission(Leakage Power)

### 20dBc Data Sheet

Polarity	Frequency [MHz]	Detector	Reading [dBuV]	Ant Factor [dB/m]	Loss [dB]	Gain [dB]	Result [dBuV/m]	Limit [dBuV/m]	Margin [dB]	Remark
Hori	2402.000	PK	101.8	27.0	5.0	34.6	99.2	-	-	Carrier
Hori	2400.000	PK	45.2	27.0	5.0	34.6	42.6	79.2	36.6	
Vert	2402.000	PK	98.0	27.0	5.0	34.6	95.4	-	-	Carrier
Vert	2400.000	PK	42.1	27.0	5.0	34.6	39.5	75.4	35.9	

Result = Reading + Ant Factor + Loss (Cable+Attenuator+Filter+Distance factor(above 1 GHz)) - Gain(Amplifier)

**UL Japan, Inc.**

**Ise EMC Lab.**

4383-326 Asama-cho, Ise-shi, Mie-ken 516-0021 JAPAN

Telephone : +81 596 24 8999

Facsimile : +81 596 24 8124

**Radiated Spurious Emission**  
**(Reference Plot for band-edge)**

Test place Ise EMC Lab. No.2 Semi Anechoic Chamber  
Report No. 11774441H  
Date July 12, 2017  
Temperature / Humidity 22 deg. C / 66 % RH  
Engineer Tomoki Matsui  
(1 GHz -10 GHz)  
Mode Tx BT LE 2402 MHz

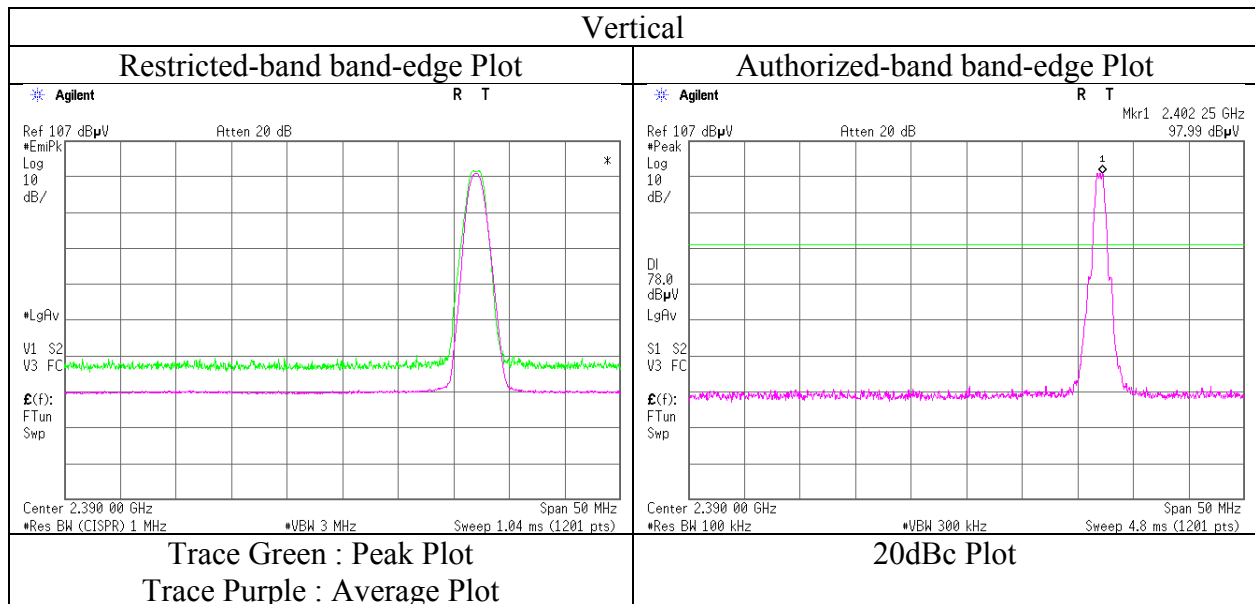
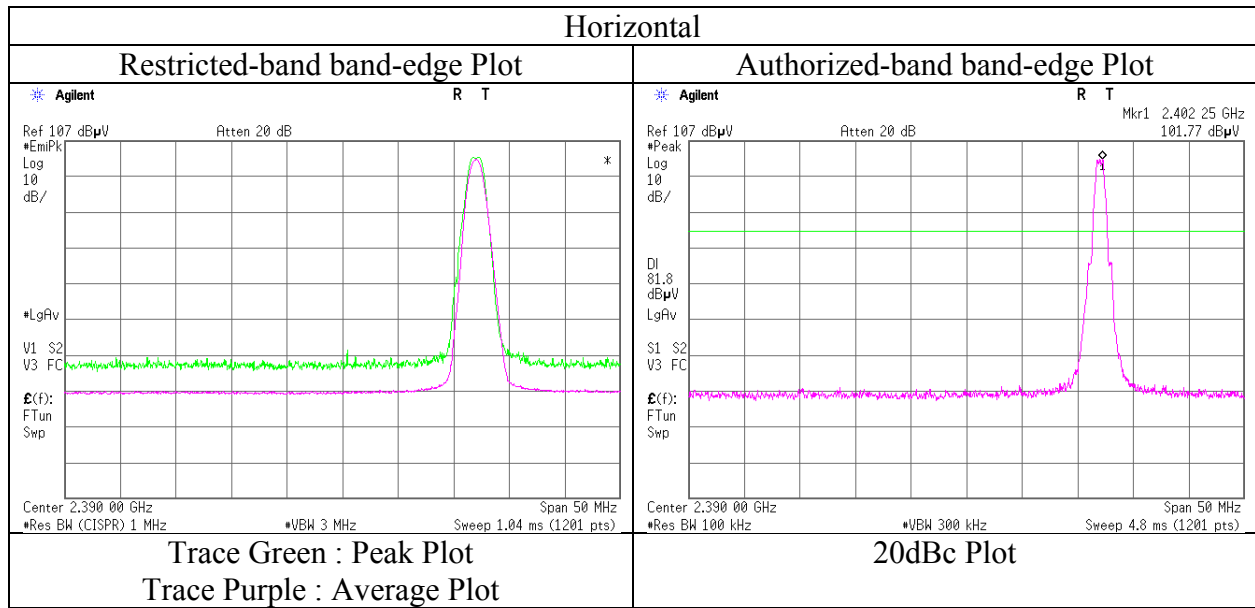

\* Final result of restricted band edge was shown in tabular data.

## Radiated Spurious Emission

Test place	Ise EMC Lab. No.2 Semi Anechoic Chamber		
Report No.	11774441H		
Date	July 12, 2017	July 14, 2017	July 15, 2017
Temperature / Humidity	22 deg. C / 66 % RH	21 deg. C / 57 % RH	23 deg. C / 65 % RH
Engineer	Tomoki Matsui	Masafumi Niwa	Takumi Shimada
	(1 GHz -10 GHz)	(10 GHz -26.5 GHz)	(30 MHz -1000 MHz)
Mode	Tx BT LE 2440 MHz		

Polarity	Frequency [MHz]	Detector	Reading [dBuV]	Ant.Fac. [dB/m]	Loss [dB]	Gain [dB]	Duty Factor [dB]	Result [dBuV/m]	Limit [dBuV/m]	Margin [dB]	Remark
Hori	40.000	QP	24.7	14.1	6.8	28.2	-	17.4	40.0	22.6	Floor noise
Hori	100.000	QP	25.9	10.1	7.4	28.0	-	15.4	43.5	28.1	Floor noise
Hori	150.000	QP	23.8	14.8	7.8	27.8	-	18.6	43.5	24.9	Floor noise
Hori	300.000	QP	23.2	13.4	8.8	27.2	-	18.2	46.0	27.8	Floor noise
Hori	500.000	QP	23.9	17.7	9.8	28.1	-	23.3	46.0	22.7	Floor noise
Hori	700.000	QP	22.8	19.8	10.5	27.6	-	25.5	46.0	20.5	Floor noise
Hori	4880.000	PK	43.0	31.4	7.5	33.8	-	48.1	73.9	25.8	Floor noise
Hori	7320.000	PK	42.2	35.8	8.5	33.9	-	52.6	73.9	21.3	Floor noise
Hori	9760.000	PK	42.3	38.2	9.2	34.5	-	55.2	73.9	18.7	Floor noise
Hori	4880.000	AV	33.9	31.4	7.5	33.8	-	39.0	53.9	14.9	Floor noise
Hori	7320.000	AV	33.3	35.8	8.5	33.9	-	43.7	53.9	10.2	Floor noise
Hori	9760.000	AV	33.6	38.2	9.2	34.5	-	46.5	53.9	7.4	Floor noise
Vert	40.000	QP	24.7	14.1	6.8	28.2	-	17.4	40.0	22.6	Floor noise
Vert	100.000	QP	24.8	10.1	7.4	28.0	-	14.3	43.5	29.2	Floor noise
Vert	150.000	QP	23.9	14.8	7.8	27.8	-	18.7	43.5	24.8	Floor noise
Vert	300.000	QP	23.1	13.4	8.8	27.2	-	18.1	46.0	27.9	Floor noise
Vert	500.000	QP	23.9	17.7	9.8	28.1	-	23.3	46.0	22.7	Floor noise
Vert	700.000	QP	22.9	19.8	10.5	27.6	-	25.6	46.0	20.4	Floor noise
Vert	4880.000	PK	43.0	31.4	7.5	33.8	-	48.1	73.9	25.8	Floor noise
Vert	7320.000	PK	42.2	35.8	8.5	33.9	-	52.6	73.9	21.3	Floor noise
Vert	9760.000	PK	42.3	38.2	9.2	34.5	-	55.2	73.9	18.7	Floor noise
Vert	4880.000	AV	33.9	31.4	7.5	33.8	-	39.0	53.9	14.9	Floor noise
Vert	7320.000	AV	33.3	35.8	8.5	33.9	-	43.7	53.9	10.2	Floor noise
Vert	9760.000	AV	33.6	38.2	9.2	34.5	-	46.5	53.9	7.4	Floor noise

Result = Reading + Ant Factor + Loss (Cable+Attenuator+Filter+Distance factor(above 1 GHz)) - Gain(Amplifier)

\*Other frequency noises omitted in this report were not seen or had enough margin (more than 20 dB).

Distance factor:      1 GHz - 10 GHz      20log (3.75 m / 3.0 m) = 1.94 dB  
                                 10 GHz - 26.5 GHz 20log (1.0 m / 3.0 m) = -9.5 dB



## Radiated Spurious Emission

Test place	Ise EMC Lab. No.2 Semi Anechoic Chamber		
Report No.	11774441H		
Date	July 12, 2017	July 14, 2017	July 15, 2017
Temperature / Humidity	22 deg. C / 66 % RH	21 deg. C / 57 % RH	23 deg. C / 65 % RH
Engineer	Tomoki Matsui	Masafumi Niwa	Takumi Shimada
	(1 GHz -10 GHz)	(10 GHz -26.5 GHz)	(30 MHz -1000 MHz)
Mode	Tx BT LE 2480 MHz		

Polarity	Frequency [MHz]	Detector	Reading [dBuV]	Ant.Fac. [dB/m]	Loss [dB]	Gain [dB]	Duty Factor [dB]	Result [dBuV/m]	Limit [dBuV/m]	Margin [dB]	Remark
Hori	40.000	QP	24.7	14.1	6.8	28.2	-	17.4	40.0	22.6	Floor noise
Hori	100.000	QP	25.9	10.1	7.4	28.0	-	15.4	43.5	28.1	Floor noise
Hori	150.000	QP	23.9	14.8	7.8	27.8	-	18.7	43.5	24.8	Floor noise
Hori	300.000	QP	23.2	13.4	8.8	27.2	-	18.2	46.0	27.8	Floor noise
Hori	500.000	QP	23.9	17.7	9.8	28.1	-	23.3	46.0	22.7	Floor noise
Hori	700.000	QP	22.9	19.8	10.5	27.6	-	25.6	46.0	20.4	Floor noise
Hori	2483.500	PK	47.5	27.0	5.1	34.6	-	45.0	73.9	28.9	
Hori	4960.000	PK	42.6	31.6	7.6	33.8	-	48.0	73.9	25.9	Floor noise
Hori	7440.000	PK	42.4	35.9	8.5	34.0	-	52.8	73.9	21.1	Floor noise
Hori	9920.000	PK	42.8	38.2	9.3	34.6	-	55.7	73.9	18.2	Floor noise
Hori	2483.500	AV	37.4	27.0	5.1	34.6	1.9	36.8	53.9	17.1	*1)
Hori	4960.000	AV	33.3	31.6	7.3	33.8	-	38.4	53.9	15.5	Floor noise
Hori	7440.000	AV	33.3	35.9	8.5	34.0	-	43.7	53.9	10.2	Floor noise
Hori	9920.000	AV	34.4	38.2	9.1	34.6	-	47.1	53.9	6.8	Floor noise
Vert	40.000	QP	24.6	14.1	6.8	28.2	-	17.3	40.0	22.7	Floor noise
Vert	100.000	QP	24.8	10.1	7.4	28.0	-	14.3	43.5	29.2	Floor noise
Vert	150.000	QP	23.9	14.8	7.8	27.8	-	18.7	43.5	24.8	Floor noise
Vert	300.000	QP	23.1	13.4	8.8	27.2	-	18.1	46.0	27.9	Floor noise
Vert	500.000	QP	23.8	17.7	9.8	28.1	-	23.2	46.0	22.8	Floor noise
Vert	700.000	QP	22.9	19.8	10.5	27.6	-	25.6	46.0	20.4	Floor noise
Vert	2483.500	PK	45.2	27.0	5.1	34.6	-	42.7	73.9	31.2	
Vert	4960.000	PK	42.6	31.6	7.6	33.8	-	48.0	73.9	25.9	Floor noise
Vert	7440.000	PK	42.4	35.9	8.5	34.0	-	52.8	73.9	21.1	Floor noise
Vert	9920.000	PK	42.8	38.2	9.3	34.6	-	55.7	73.9	18.2	Floor noise
Vert	2483.500	AV	36.1	27.0	5.1	34.6	1.9	35.5	53.9	18.4	*1)
Vert	4960.000	AV	33.3	31.6	7.3	33.8	-	38.4	53.9	15.5	Floor noise
Vert	7440.000	AV	33.3	35.9	8.5	34.0	-	43.7	53.9	10.2	Floor noise
Vert	9920.000	AV	34.4	38.2	9.1	34.6	-	47.1	53.9	6.8	Floor noise

Result = Reading + Ant Factor + Loss (Cable+Attenuator+Filter+Distance factor(above 1 GHz)) - Gain(Amplifier) + Duty factor

\*Other frequency noises omitted in this report were not seen or had enough margin (more than 20 dB).

Distance factor: 1 GHz - 10 GHz  $20\log(3.75\text{ m} / 3.0\text{ m}) = 1.94\text{ dB}$   
10 GHz - 26.5 GHz  $20\log(1.0\text{ m} / 3.0\text{ m}) = -9.5\text{ dB}$

\*1) Not Out of Band emission(Leakage Power)

**Radiated Spurious Emission**  
**(Reference Plot for band-edge)**

Test place	Ise EMC Lab. No.2 Semi Anechoic Chamber
Report No.	11774441H
Date	July 12, 2017
Temperature / Humidity	22 deg. C / 66 % RH
Engineer	Tomoki Matsui (1 GHz -10 GHz)
Mode	Tx BT LE 2480 MHz

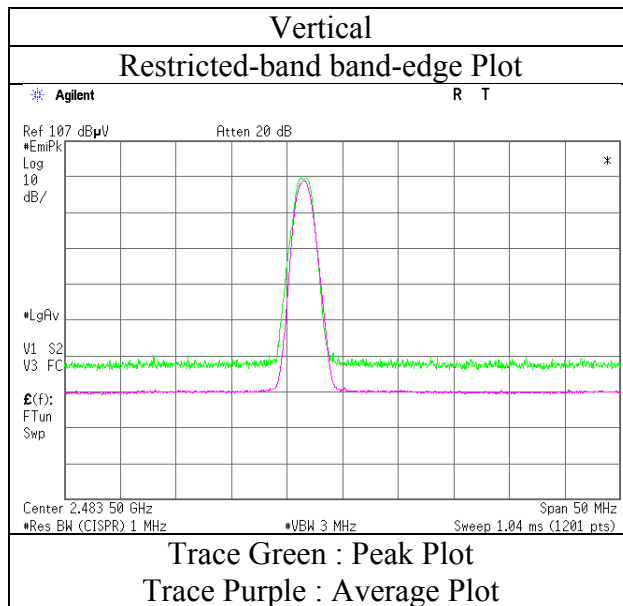
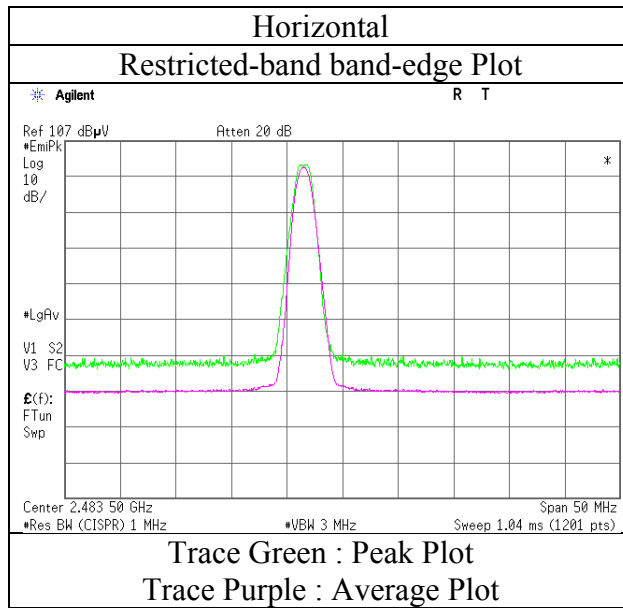

\* Final result of restricted band edge was shown in tabular data.

**Radiated Spurious Emission**  
**(Plot data, Worst case)**

Test place	Ise EMC Lab. No.2 Semi Anechoic Chamber		
Report No.	11774441H		
Date	July 12, 2017	July 14, 2017	July 15, 2017
Temperature / Humidity	22 deg. C / 66 % RH	21 deg. C / 57 % RH	23 deg. C / 65 % RH
Engineer	Tomoki Matsui	Masafumi Niwa	Takumi Shimada
	(1 GHz -10 GHz)	(10 GHz -26.5 GHz)	(30 MHz -1000 MHz)
Mode	Tx BT LE 2402 MHz		

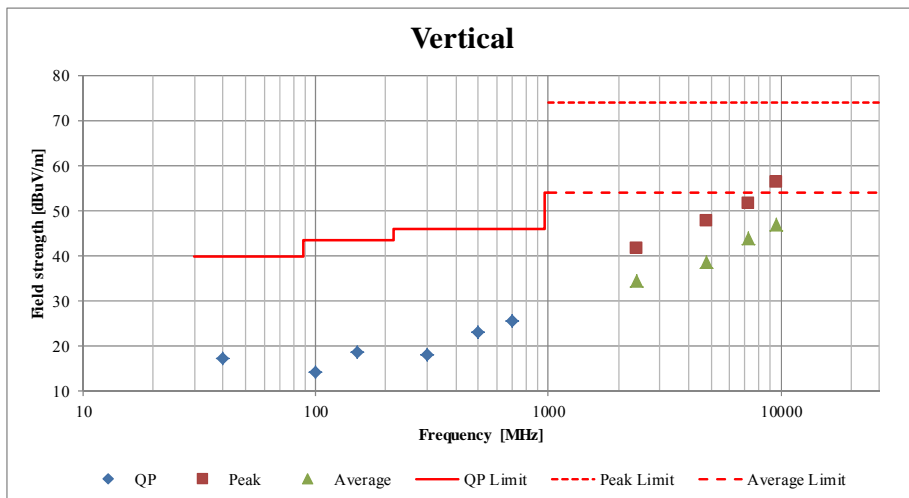
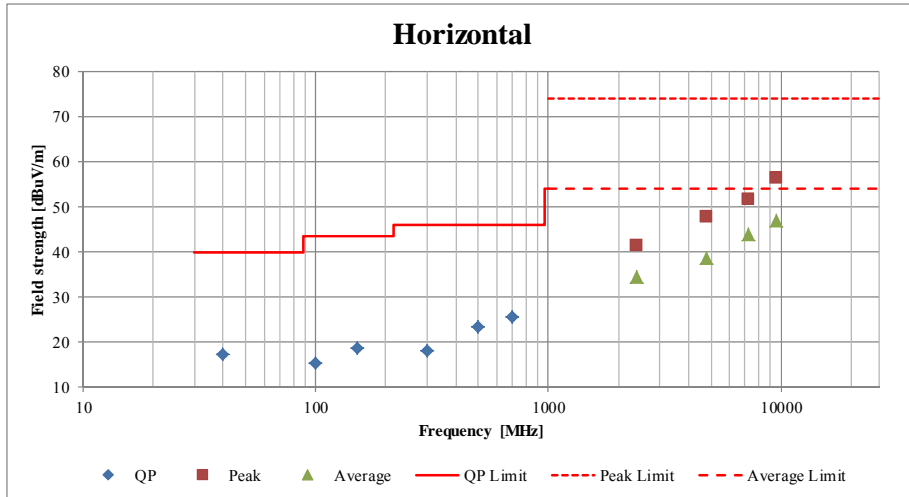

\*These plots data contains sufficient number to show the trend of characteristic features for EUT.

## Conducted Spurious Emission

Test place	Ise EMC Lab. No.11 Measurement Room
Report No.	11774441H
Date	July 13, 2017
Temperature / Humidity	24 deg. C / 62 % RH
Engineer	Takafumi Noguchi
Mode	Tx 11n-20 2462 MHz

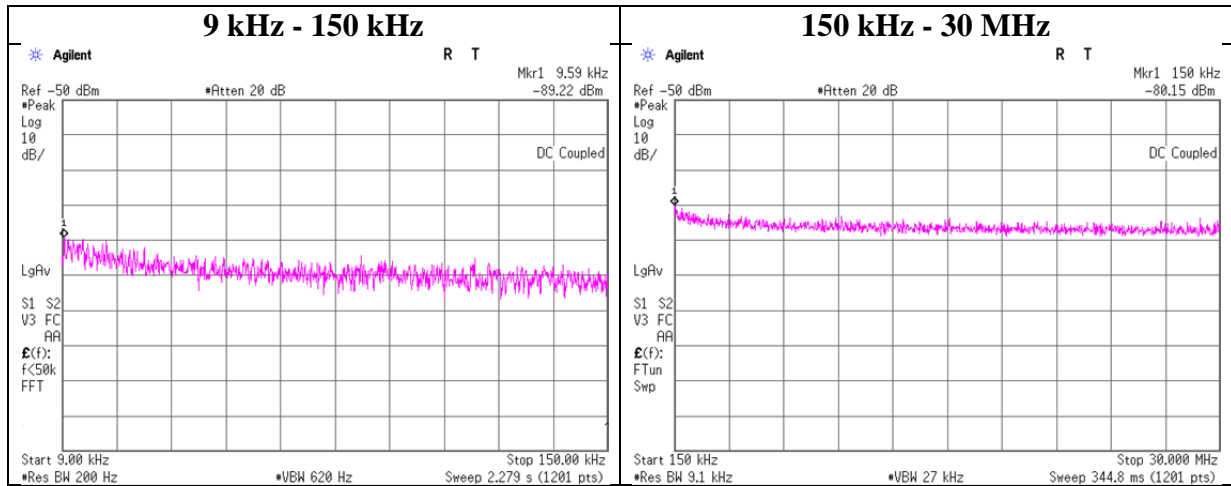

Frequency [kHz]	Reading [dBm]	Cable Loss [dB]	Attenuator Loss [dB]	Antenna Gain* [dBi]	N (Number of Output)	EIRP [dBm]	Distance [m]	Ground bounce [dB]	E (field strength) [dBuV/m]	Limit [dBuV/m]	Margin [dB]	Remark
9.59	-89.2	0.80	9.8	2.0	1	-76.6	300	6.0	-15.3	47.9	63.2	
150.00	-80.2	0.80	9.8	2.0	1	-67.5	300	6.0	-6.3	24.0	30.3	

$$E \text{ [dBuV/m]} = \text{EIRP [dBm]} - 20 \log (\text{Distance [m]}) + \text{Ground bounce [dB]} + 104.8 \text{ [dBuV/m]}$$

$$\text{EIRP [dBm]} = \text{Reading [dBm]} + \text{Cable loss [dB]} + \text{Attenuator Loss [dB]} + \text{Antenna gain [dBi]} + 10 * \log (N)$$

N: Number of output

\*2.0 dBi was applied to the test result based on KDB 558074 since antenna gain was less than 2.0 dBi.

**UL Japan, Inc.**

**Ise EMC Lab.**

4383-326 Asama-cho, Ise-shi, Mie-ken 516-0021 JAPAN

Telephone : +81 596 24 8999

Facsimile : +81 596 24 8124

### Conducted Spurious Emission

Test place : Ise EMC Lab. No.11 Measurement Room  
Report No. : 11774441H  
Date : July 13, 2017  
Temperature / Humidity : 24 deg. C / 62 % RH  
Engineer : Takafumi Noguchi  
Mode : Tx BT LE 2402 MHz

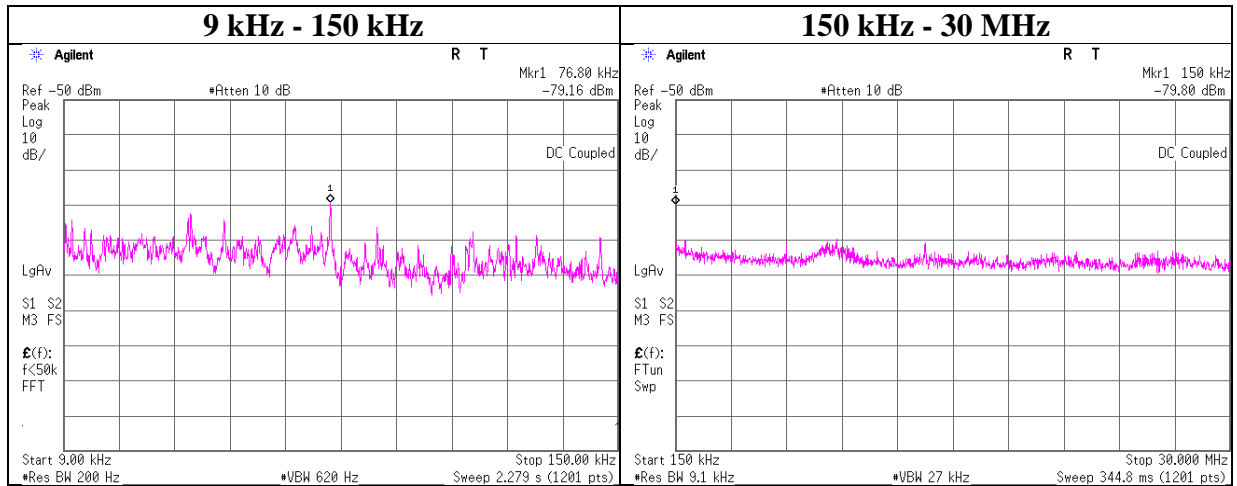

Frequency [kHz]	Reading [dBm]	Cable Loss [dB]	Attenuator Loss [dB]	Antenna Gain* [dBi]	N (Number of Output)	EIRP [dBm]	Distance [m]	Ground bounce [dB]	E (field strength) [dBuV/m]	Limit [dBuV/m]	Margin [dB]	Remark
76.80	-79.2	0.80	9.8	2.0	1	-66.5	300	6.0	-5.3	29.8	35.1	
150.00	-79.8	0.80	9.8	2.0	1	-67.2	300	6.0	-5.9	24.0	29.9	

$E \text{ [dBuV/m]} = \text{EIRP [dBm]} - 20 \log(\text{Distance [m]}) + \text{Ground bounce [dB]} + 104.8 \text{ [dBuV/m]}$

$\text{EIRP [dBm]} = \text{Reading [dBm]} + \text{Cable loss [dB]} + \text{Attenuator Loss [dB]} + \text{Antenna gain [dBi]} + 10 * \log(N)$

N: Number of output

\*2.0 dBi was applied to the test result based on KDB 558074 since antenna gain was less than 2.0 dBi.

## Conducted Spurious Emission

Test place	Ise EMC Lab. No.11 Measurement Room
Report No.	11774441H
Date	July 13, 2017
Temperature / Humidity	24 deg. C / 62 % RH
Engineer	Takafumi Noguchi
Mode	Tx BT LE 2440 MHz

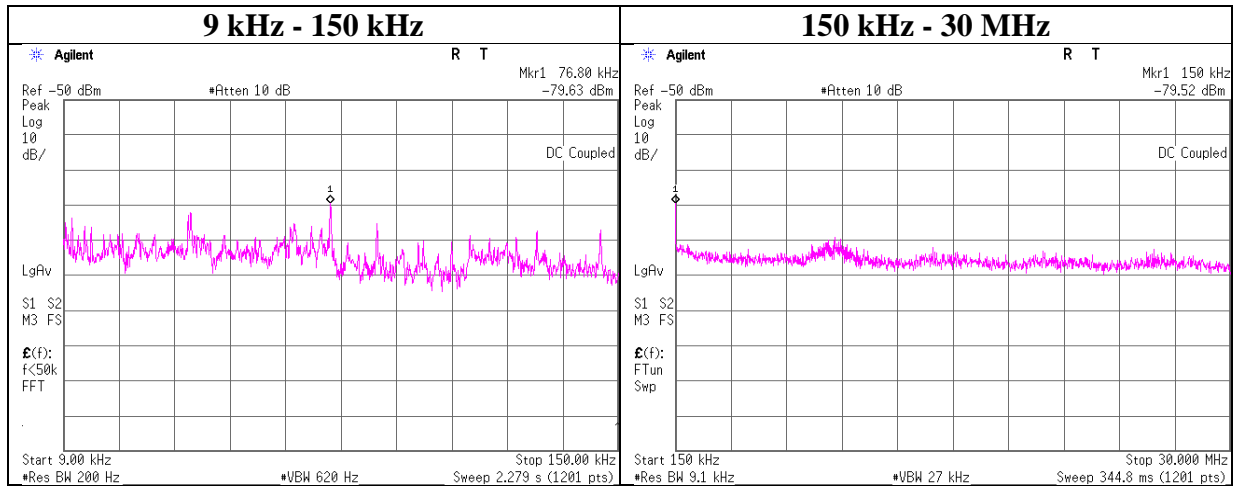

Frequency [kHz]	Reading [dBm]	Cable Loss [dB]	Attenuator Loss [dB]	Antenna Gain* [dBi]	N (Number of Output)	EIRP [dBm]	Distance [m]	Ground bounce [dB]	E (field strength) [dBuV/m]	Limit [dBuV/m]	Margin [dB]	Remark
76.63	-79.6	0.80	9.8	2.0	1	-67.0	300	6.0	-5.7	29.9	35.6	
150.00	-79.5	0.80	9.8	2.0	1	-66.9	300	6.0	-5.6	24.0	29.6	

$$E \text{ [dBuV/m]} = \text{EIRP [dBm]} - 20 \log(\text{Distance [m]}) + \text{Ground bounce [dB]} + 104.8 \text{ [dBuV/m]}$$

$$\text{EIRP [dBm]} = \text{Reading [dBm]} + \text{Cable loss [dB]} + \text{Attenuator Loss [dB]} + \text{Antenna gain [dBi]} + 10 * \log(N)$$

N: Number of output

\*2.0 dBi was applied to the test result based on KDB 558074 since antenna gain was less than 2.0 dBi.

## Conducted Spurious Emission

Test place : Ise EMC Lab. No.11 Measurement Room  
Report No. : 11774441H  
Date : July 13, 2017  
Temperature / Humidity : 24 deg. C / 62 % RH  
Engineer : Takafumi Noguchi  
Mode : Tx BT LE 2480 MHz

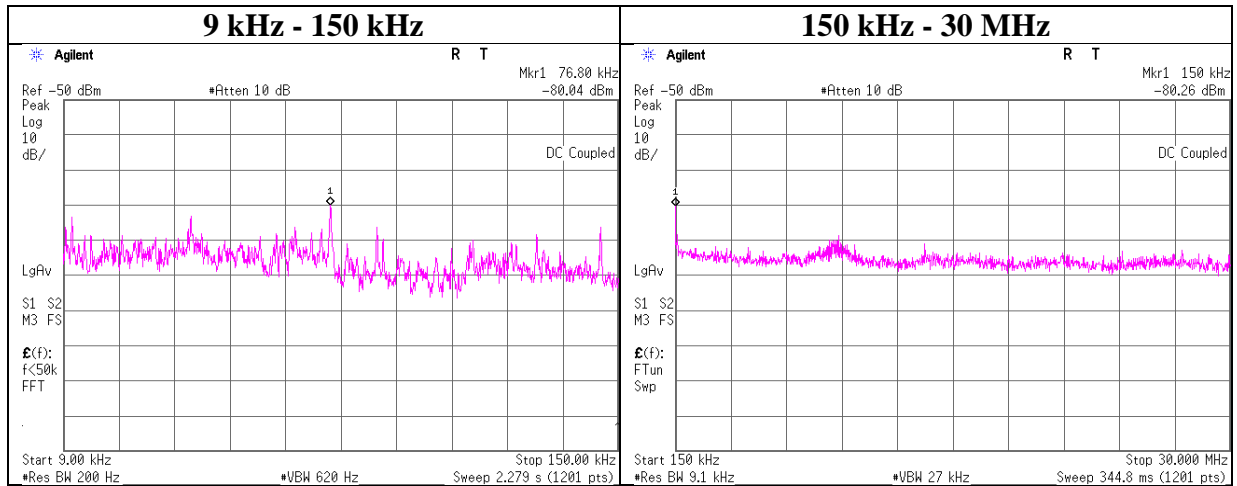

Frequency [kHz]	Reading [dBm]	Cable Loss [dB]	Attenuator Loss [dB]	Antenna Gain* [dBi]	N (Number of Output)	EIRP [dBm]	Distance [m]	Ground bounce [dB]	E (field strength) [dBuV/m]	Limit [dBuV/m]	Margin [dB]	Remark
76.80	-80.0	0.80	9.8	2.0	1	-67.4	300	6.0	-6.1	29.8	35.9	
150.00	-80.3	0.80	9.8	2.0	1	-67.6	300	6.0	-6.4	24.0	30.4	

$$E \text{ [dBuV/m]} = \text{EIRP [dBm]} - 20 \log(\text{Distance [m]}) + \text{Ground bounce [dB]} + 104.8 \text{ [dBuV/m]}$$

$$\text{EIRP [dBm]} = \text{Reading [dBm]} + \text{Cable loss [dB]} + \text{Attenuator Loss [dB]} + \text{Antenna gain [dBi]} + 10 * \log(N)$$

N: Number of output

\*2.0 dBi was applied to the test result based on KDB 558074 since antenna gain was less than 2.0 dBi.

### Power Density

Test place Ise EMC Lab. No.11 Measurement Room  
Report No. 11774441H  
Date July 13, 2017 July 16, 2017  
Temperature / Humidity 24 deg. C / 62 % RH 27 deg. C / 42 % RH  
Engineer Takafumi Noguchi Takafumi Noguchi  
Mode Tx

11b

Freq. [MHz]	Reading [dBm]	Cable Loss [dB]	Atten. Loss [dB]	Result [dBm]	Limit [dBm]	Margin [dB]
2412.00	-16.39	0.80	10.19	-5.40	8.00	13.40
2437.00	-16.65	0.80	10.19	-5.66	8.00	13.66
2462.00	-16.61	0.80	10.19	-5.62	8.00	13.62

11g

Freq. [MHz]	Reading [dBm]	Cable Loss [dB]	Atten. Loss [dB]	Result [dBm]	Limit [dBm]	Margin [dB]
2412.00	-23.17	0.80	10.19	-12.18	8.00	20.18
2437.00	-22.98	0.80	10.19	-11.99	8.00	19.99
2462.00	-22.96	0.80	10.19	-11.97	8.00	19.97

11n-20

Freq. [MHz]	Reading [dBm]	Cable Loss [dB]	Atten. Loss [dB]	Result [dBm]	Limit [dBm]	Margin [dB]
2412.00	-22.65	0.80	10.19	-11.66	8.00	19.66
2437.00	-23.91	0.80	10.19	-12.92	8.00	20.92
2462.00	-22.89	0.80	10.19	-11.90	8.00	19.90

Sample Calculation:

Result = Reading + Cable Loss (including the cable(s) customer supplied) + Attenuator Loss



**Power Density**

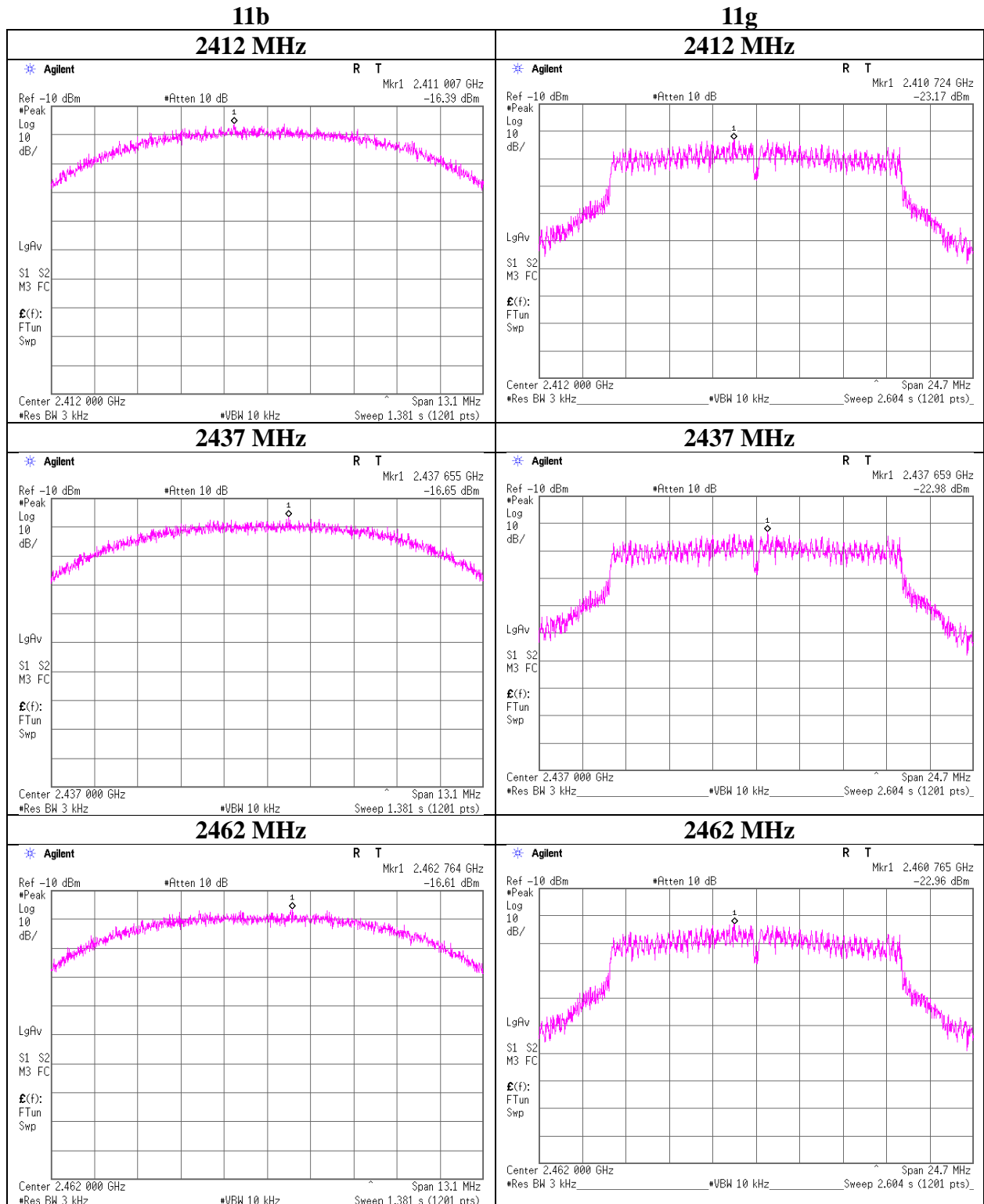

## Power Density

11n-20

2412 MHz

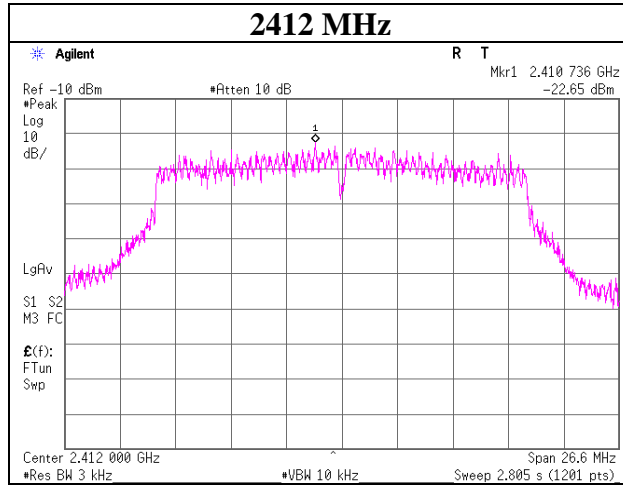

2437 MHz

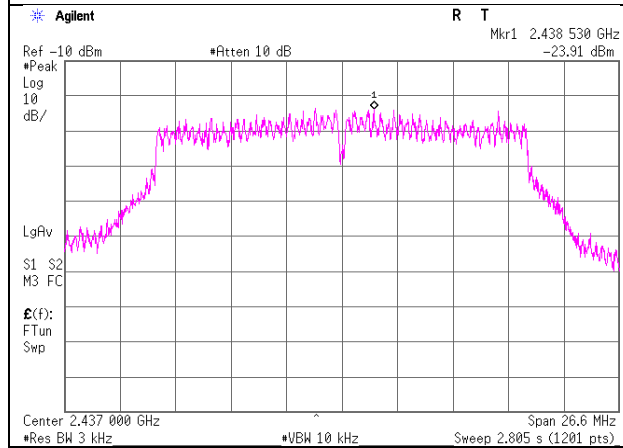

2462 MHz

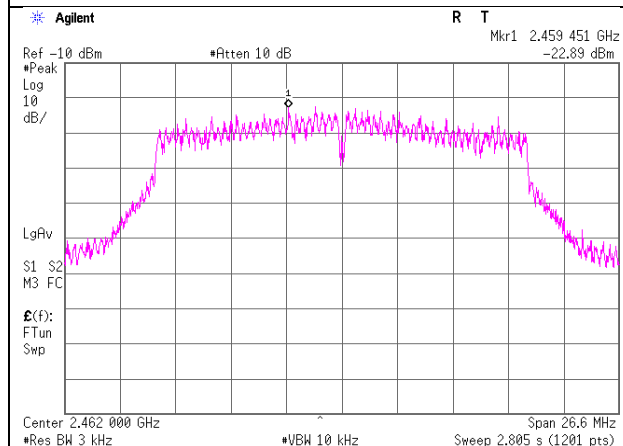

UL Japan, Inc.

Ise EMC Lab.

4383-326 Asama-cho, Ise-shi, Mie-ken 516-0021 JAPAN

Telephone : +81 596 24 8999

Facsimile : +81 596 24 8124

### Power Density

Test place : Ise EMC Lab. No.6 Measurement Room  
Report No. : 11774441H  
Date : July 14, 2017  
Temperature / Humidity : 25 deg. C / 58 % RH  
Engineer : Takumi Shimada  
Mode : Tx BT LE

BT LE

Freq. [MHz]	Reading [dBm]	Cable Loss [dB]	Atten. Loss [dB]	Result [dBm]	Limit [dBm]	Margin [dB]
2402.00	-19.50	0.80	10.19	-8.51	8.00	16.51
2440.00	-20.63	0.80	10.19	-9.64	8.00	17.64
2480.00	-20.88	0.80	10.20	-9.88	8.00	17.88

Sample Calculation:

Result = Reading + Cable Loss (including the cable(s) customer supplied) + Attenuator Loss

## Power Density

### BT LE

#### 2402 MHz

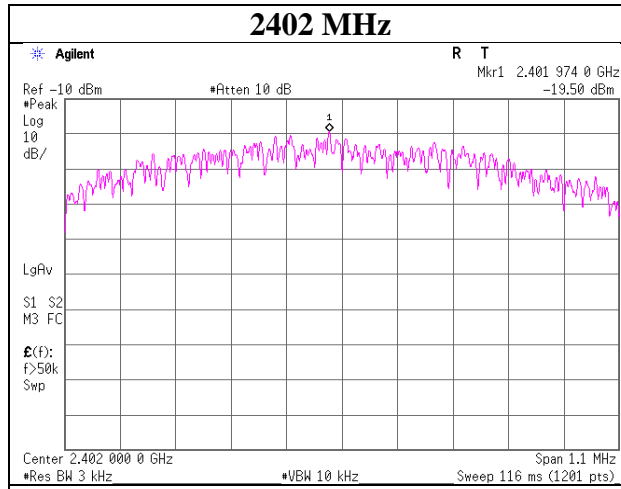

#### 2440 MHz

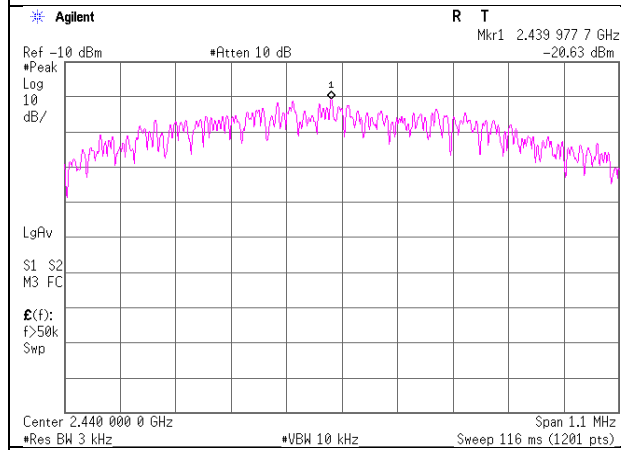

#### 2480 MHz

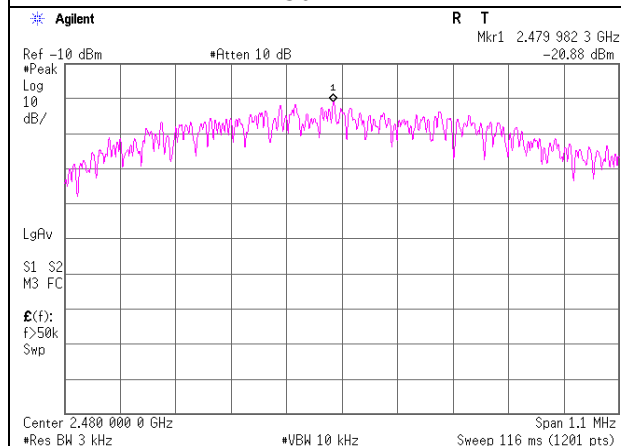

UL Japan, Inc.

Ise EMC Lab.

4383-326 Asama-cho, Ise-shi, Mie-ken 516-0021 JAPAN

Telephone : +81 596 24 8999

Facsimile : +81 596 24 8124

## 99% Occupied Bandwidth

Test place	Ise EMC Lab. No.11 Measurement Room
Report No.	11774441H
Date	July 13, 2017
Temperature / Humidity	24 deg. C / 62 % RH
Engineer	Takafumi Noguchi
Mode	Tx

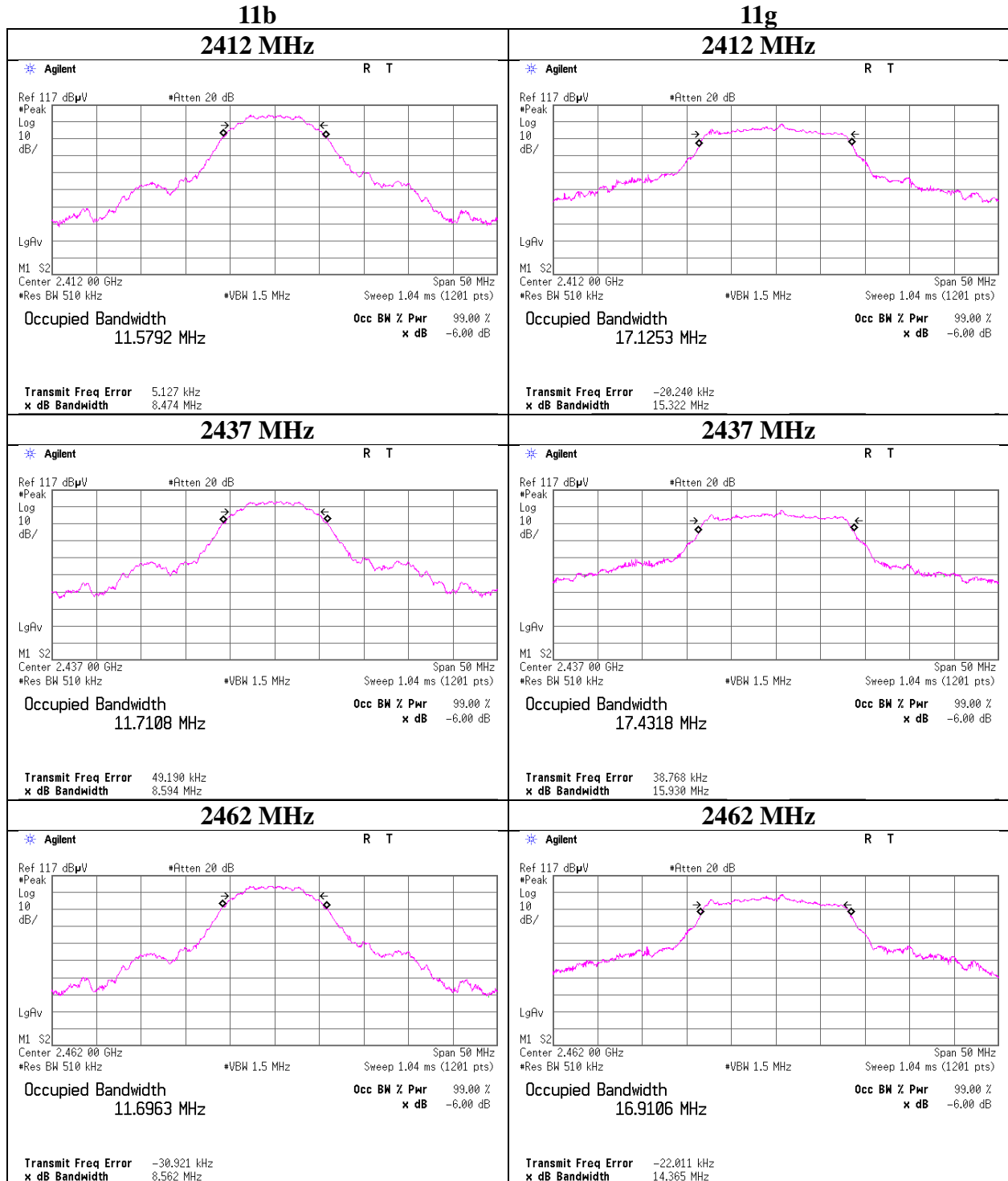

## 99% Occupied Bandwidth

Test place	Ise EMC Lab. No.11 Measurement Room
Report No.	11774441H
Date	July 13, 2017
Temperature / Humidity	24 deg. C / 62 % RH
Engineer	Takafumi Noguchi
Mode	Tx

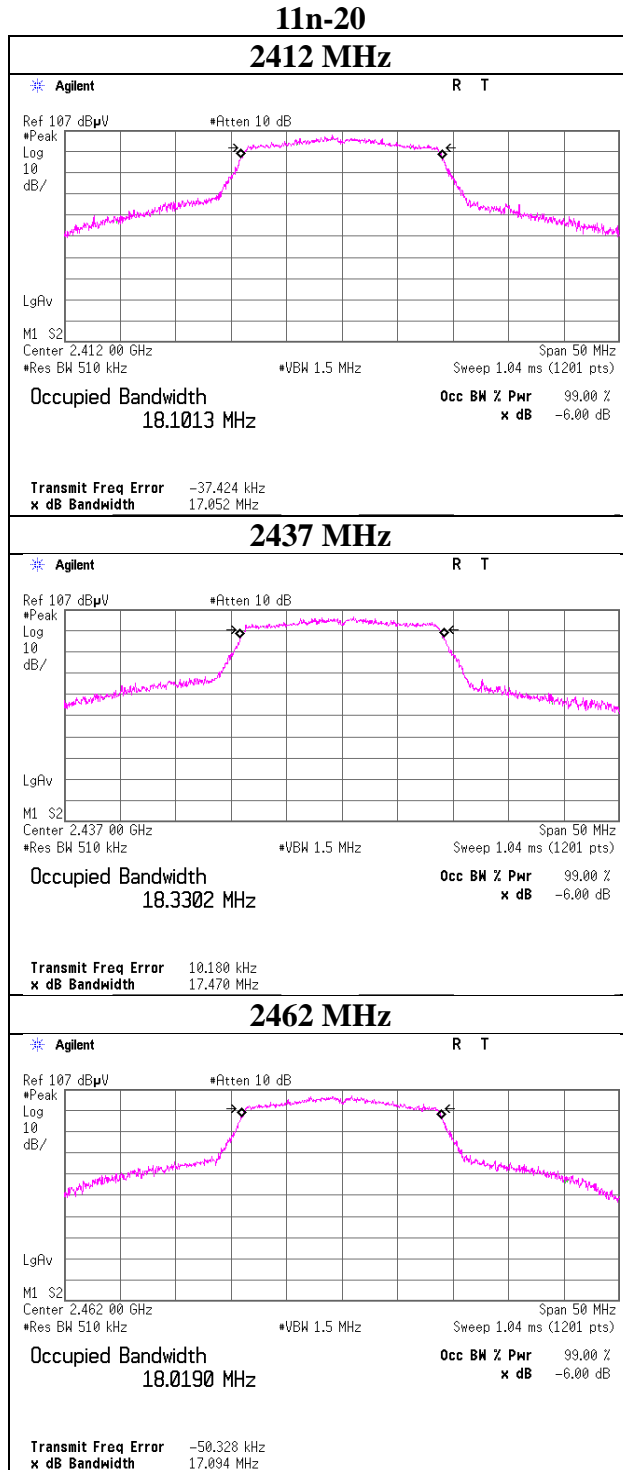

## 99% Occupied Bandwidth

Test place	Ise EMC Lab. No.6 Measurement Room
Report No.	11774441H
Date	July 14, 2017
Temperature / Humidity	25 deg. C / 58 % RH
Engineer	Takumi Shimada
Mode	Tx

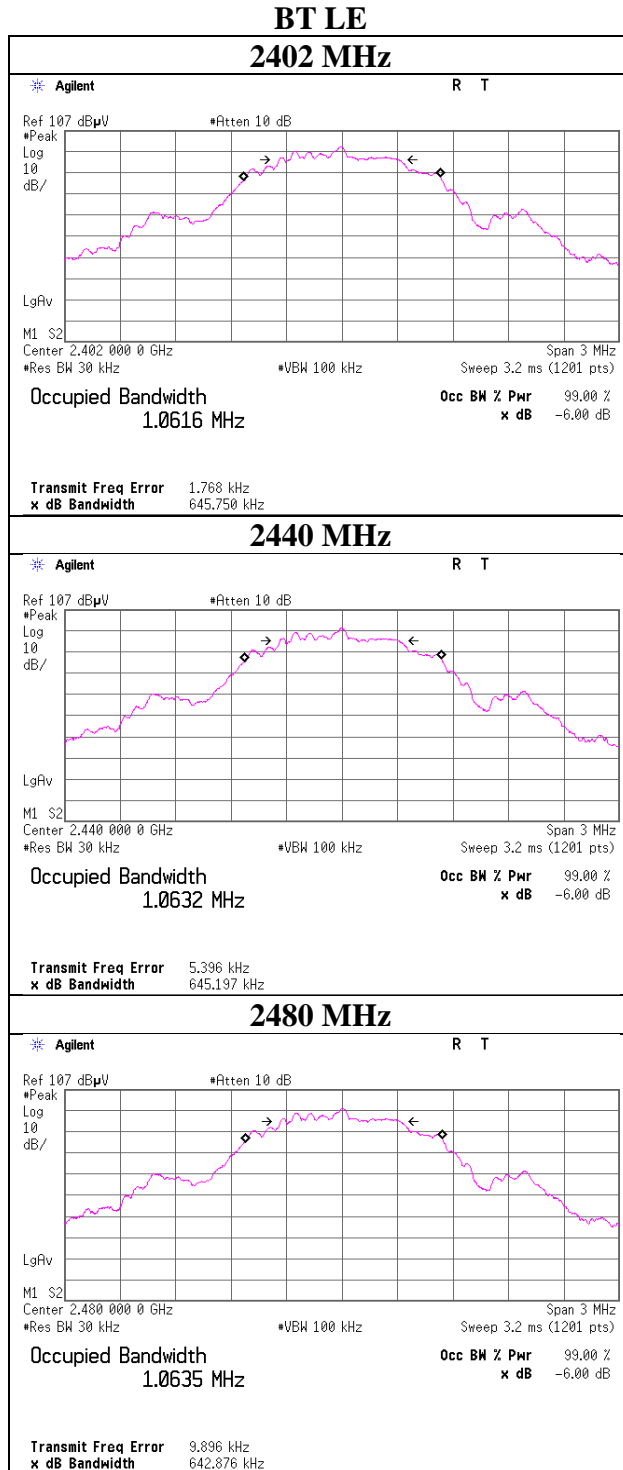

**UL Japan, Inc.**

**Ise EMC Lab.**

4383-326 Asama-cho, Ise-shi, Mie-ken 516-0021 JAPAN

Telephone : +81 596 24 8999

Facsimile : +81 596 24 8124

## APPENDIX 2: Test instruments

### Test equipment

Control No.	Instrument	Manufacturer	Model No	Serial No	Test Item	Calibration Date * Interval(month)
MPSE-11	Power sensor	Anritsu	MA2411B	011737	AT	2016/10/07 * 12
MAT-56	Attenuator(10dB)	Suhner	6810.19.A	-	AT	2016/12/14 * 12
MOS-19	Thermo-Hygrometer	Custom	CTH-201	0001	AT	2016/12/13 * 12
MCC-174	Microwave Cable	Junkosha	MWX221	1409S497	AT	2017/03/13 * 12
MAT-22	Attenuator(10dB) 1-18GHz	Orient Microwave	BX10-0476-00	-	AT	2017/03/21 * 12
MSA-15	Spectrum Analyzer	Agilent	E4440A	MY46187105	AT	2016/10/13 * 12
MPM-08	Power Meter	Anritsu	ML2495A	6K00003338	AT	2016/10/07 * 12
MMM-17	DIGITAL HiTESTER	Hioki	3805	070900530	AT	2017/01/19 * 12
MAEC-02	Semi Anechoic Chamber(NSA)	TDK	Semi Anechoic Chamber 3m	DA-06902	RE	2016/08/02 * 12 *1)
MOS-22	Thermo-Hygrometer	Custom	CTH-201	0003	RE	2016/12/13 * 12
MJM-14	Measure	KOMELON	KMC-36	-	RE	-
COTS-MEMI	EMI measurement program	TSJ	TEPTO-DV	-	RE./ CE	-
MSA-14	Spectrum Analyzer	Agilent	E4440A	MY48250080	RE	2016/10/14 * 12
MHA-06	Horn Antenna 1-18GHz	Schwarzbeck	BBHA9120D	254	RE	2017/02/24 * 12
MCC-216	Microwave Cable	Junkosha	MWX221	1604S253(1 m) / 1608S087(5 m)	RE	2016/08/29 * 12 *1)
MPA-10	Pre Amplifier	Agilent	8449B	3008A02142	RE	2017/01/16 * 12
MMM-01	Digital Tester	Fluke	FLUKE 26-3	78030611	RE	2016/08/23 * 12 *1)
MHF-26	High Pass Filter 3.5-18.0GHz	UL Japan	HPF SELECTOR	002	RE	2016/09/19 * 12
MHA-02	Horn Antenna 18-26.5GHz	EMCO	3160-09	1265	RE	2017/02/24 * 12
MHA-29	Horn Antenna 26.5-40GHz	ETS LINDGREN	3160-10	00152399	RE	2016/09/28 * 12
MPA-22	Pre Amplifier	MITEQ, Inc	AMF-6F-2600400-3 3-8P / AMF-4F-2600400-3 3-8P	1871355 /1871328	RE	2016/09/06 * 12
MCC-55	Microwave Cable	Suhner	SUCOFLEX101	2874(1m) / 2877(5m)	RE	2017/03/02 * 12
MSA-04	Spectrum Analyzer	Agilent	E4448A	US44300523	RE	2016/11/10 * 12
MBA-08	Biconical Antenna	Schwarzbeck	VHA9103B	08031	RE	2016/09/29 * 12
MLA-21	Logperiodic Antenna(200-1000MHz)	Schwarzbeck	VUSLP9111B	911B-190	RE	2017/01/05 * 12
MAT-07	Attenuator(6dB)	Weinschel Corp	2	BK7970	RE	2016/11/28 * 12
MCC-12	Coaxial Cable	Fujikura/Agilent	-	-	RE	2017/02/24 * 12
MPA-09	Pre Amplifier	Agilent	8447D	2944A10845	RE	2016/09/13 * 12
MTR-03	Test Receiver	Rohde & Schwarz	ESCI	100300	RE	2016/10/21 * 12
MSA-16	Spectrum Analyzer	Agilent	E4440A	MY46186390	AT	2017/02/21 * 12
MPM-16	Power Meter	Agilent	8990B	MY51000271	AT	2017/04/28 * 12
MPSE-22	Power sensor	Agilent	N1923A	MY54070003	AT	2017/04/28 * 12
MAT-10	Attenuator(10dB)	Weinschel Corp	2	BL1173	AT	2016/11/28 * 12
MAEC-03	Semi Anechoic Chamber(NSA)	TDK	Semi Anechoic Chamber 3m	DA-10005	CE	2016/10/20 * 12
MOS-13	Thermo-Hygrometer	Custom	CTH-180	1301	CE	2017/01/20 * 12
MJM-16	Measure	KOMELON	KMC-36	-	CE	-
MSA-03	Spectrum Analyzer	Agilent	E4448A	MY44020357	CE	2017/05/29 * 12
MTR-08	Test Receiver	Rohde & Schwarz	ESCI	100767	CE	2016/09/15 * 12
MLS-23	LISN(AMN)	Schwarzbeck	NSLK8127	8127-729	CE(EUT)	2016/07/07 * 12 *1)
MCC-112	Coaxial cable	Fujikura/Suhner/TSJ	5D-2W(10m)/SFM14 1(3m)/sucoform141- PE(1m)/421-010(1.5 m)/RFM-E321(Switc her)	-/00640	CE	2017/07/12 * 12
MAT-66	Attenuator(13dB)	JFW Industries, Inc.	50FP-013H2 N	-	CE	2016/12/24 * 12
MMM-08	DIGITAL HiTESTER	Hioki	3805	051201197	CE	2017/01/19 * 12

**UL Japan, Inc.**

**Ise EMC Lab.**

4383-326 Asama-cho, Ise-shi, Mie-ken 516-0021 JAPAN

Telephone : +81 596 24 8999

Facsimile : +81 596 24 8124



**\*1) This test equipment was used for the tests before the expiration date of the calibration.**

**The expiration date of the calibration is the end of the expired month.**

**All equipment is calibrated with valid calibrations. Each measurement data is traceable to the national or international standards.**

**As for some calibrations performed after the tested dates, those test equipment have been controlled by means of an unbroken chains of calibrations.**

**Test Item: CE: Conducted Emission test  
RE: Radiated Emission test  
AT: Antenna Terminal Conducted test**