



RADIO TEST REPORT

Test Report No. : 11774441H-B-R2

Applicant : Murata Manufacturing Co., Ltd.
Type of Equipment : Communication Module
Model No. : 1MW
FCC ID : VPYLB1MW
Test regulation : FCC Part 15 Subpart C: 2017
(Bluetooth part)
Test Result : Complied

1. This test report shall not be reproduced in full or partial, without the written approval of UL Japan, Inc.
2. The results in this report apply only to the sample tested.
3. This sample tested is in compliance with the above regulation.
4. The test results in this report are traceable to the national or international standards.
5. This test report must not be used by the customer to claim product certification, approval, or endorsement by NVLAP, NIST, or any agency of the Federal Government.
6. This test report covers Radio technical requirements. It does not cover administrative issues such as Manual or non-Radio test related Requirements. (if applicable)
7. This report is a revised version of 11774441H-B-R1.

Date of test: June 29 to July 20, 2017

Representative test engineer:



Takumi Shimada

Engineer

Consumer Technology Division

Approved by:

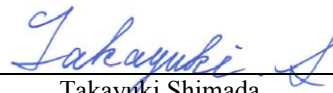

Takayuki Shimada

Engineer

Consumer Technology Division



NVLAP LAB CODE: 200572-0

This laboratory is accredited by the NVLAP LAB CODE 200572-0, U.S.A. The tests reported herein have been performed in accordance with its terms of accreditation.
*As for the range of Accreditation in NVLAP, you may refer to the WEB address,
http://japan.ul.com/resources/emc_accredited/

UL Japan, Inc.

Ise EMC Lab.

4383-326 Asama-cho, Ise-shi, Mie-ken 516-0021 JAPAN

Telephone : +81 596 24 8999

Facsimile : +81 596 24 8124

13-EM-F0429

CONTENTS	PAGE
SECTION 1: Customer information.....	4
SECTION 2: Equipment under test (E.U.T.).....	4
SECTION 3: Test specification, procedures & results.....	6
SECTION 4: Operation of E.U.T. during testing.....	9
SECTION 5: Conducted Emission.....	12
SECTION 6: Radiated Spurious Emission	13
SECTION 7: Antenna Terminal Conducted Tests.....	14
APPENDIX 1: Test data	15
Conducted Emission	15
20dB Bandwidth and Carrier Frequency Separation.....	19
Number of Hopping Frequency	22
Dwell time.....	24
Maximum Peak Output Power	27
Average Output Power	28
Radiated Spurious Emission	30
Conducted Spurious Emission	41
Conducted Emission Band Edge compliance	47
99%Occupied Bandwidth	49
APPENDIX 2: Test instruments	51
APPENDIX 3: Photographs of test setup	53
Conducted Emission	53
Radiated Spurious Emission	54
Worst Case Position	55

Radio Specification

Radio Type : Transceiver
Power Supply (inner) : DC 3.3 V

Specification of Wireless LAN (IEEE802.11b/g/a/n-20/n-40/11ac-20/11ac-40/11ac-80)

Type of radio	IEEE802.11b	IEEE802.11g/n (20 M band)	IEEE802.11a/n/ac (20 M band)	IEEE802.11n/ac (40 M band)	IEEE802.11ac (80 M band)
Frequency of operation	2412 MHz - 2462 MHz	2412 MHz - 2462 MHz	5180 MHz - 5240 MHz 5260 MHz - 5320 MHz 5500 MHz - 5720 MHz 5745 MHz - 5825 MHz	5190 MHz - 5230 MHz 5270 MHz - 5310 MHz 5510 MHz - 5710 MHz 5755 MHz - 5795 MHz	5210 MHz 5290 MHz 5530 MHz - 5690 MHz 5775 MHz
Type of modulation	DSSS (CCK, DQPSK, DBPSK)	OFDM-CCK (64QAM, 16QAM, QPSK, BPSK)	OFDM (64QAM, 16QAM, QPSK, BPSK, 256QAM(IEEE802.11ac only))		
Channel spacing	5 MHz		20 MHz	40 MHz	80 MHz
Antenna type	Monopole pattern antenna				
Antenna Gain	[RF Cable 30 mm] 2.4 GHz: 0 dBi 5 GHz: 1.5dBi [RF Cable 300 mm] 2.4 GHz: -1.3 dBi 5 GHz: -1.8 dBi				

Bluetooth (Ver. 4.2 with EDR function)

	Bluetooth Ver.4.2 with EDR function *1)
Frequency of operation	2402 MHz - 2480 MHz
Type of modulation	BT: FHSS (GFSK, $\pi/4$ DQPSK, 8DPSK) LE: GFSK
Channel spacing	BT: 1 MHz LE: 2 MHz
Antenna type	Monopole pattern antenna
Antenna Gain	[RF Cable 30 mm] 2.4 GHz: 0 dBi [RF Cable 300 mm] 2.4 GHz: -1.3 dBi

*1) This test report applies to Bluetooth Ver.4.2 with EDR function (2402 MHz - 2480 MHz) except for Bluetooth Low Energy.
* WLAN and Bluetooth do not transmit simultaneously.

SECTION 3: Test specification, procedures & results

3.1 Test Specification

Test Specification : FCC Part 15 Subpart C
FCC Part 15 final revised on June 14, 2017 and effective July 14, 2017

Title : FCC 47CFR Part15 Radio Frequency Device Subpart C Intentional Radiators
Section 15.207 Conducted limits
Section 15.247 Operation within the bands 902-928MHz,
2400-2483.5MHz, and 5725-5850MHz

* The revision on August 29, 2017, does not affect the test specification applied to the EUT.

3.2 Procedures and results

Item	Test Procedure	Specification	Worst Margin	Results	Remarks
Conducted Emission	FCC: ANSI C63.10-2013 6. Standard test methods IC: RSS-Gen 8.8	FCC: Section 15.207 IC: RSS-Gen 8.8	QP 14.9 dB, 24.00017 MHz, N/ 24.00037 MHz, L AV 13.1 dB, 24.00017 MHz, N/ 24.00037 MHz, L	Complied	-
Carrier Frequency Separation	FCC: FCC Public Notice DA 00-705 IC: -	FCC: Section15.247(a)(1) IC: RSS-247 5.1 (b)	See data.	Complied	Conducted
20dB Bandwidth	FCC: FCC Public Notice DA 00-705 IC: -	FCC: Section15.247(a)(1) IC: RSS-247 5.1 (a)		Complied	Conducted
Number of Hopping Frequency	FCC: FCC Public Notice DA 00-705 IC: -	FCC: Section15.247(a)(1)(iii) IC: RSS-247 5.1 (d)		Complied	Conducted
Dwell time	FCC: FCC Public Notice DA 00-705 IC: -	FCC: Section15.247(a)(1)(iii) IC: RSS-247 5.1 (d)		Complied	Conducted
Maximum Peak Output Power	FCC: FCC Public Notice DA 00-705 IC: RSS-Gen 6.12	FCC: Section15.247 (b)(1) IC: RSS-247 5.4 (b)		Complied	Conducted
Spurious Emission & Band Edge Compliance	FCC: FCC Public Notice DA 00-705 IC: RSS-Gen 6.13	FCC: Section15.247(d) IC: RSS-247 5.5 RSS-Gen 8.9 RSS-Gen 8.10		22.1 dB 2483.500 MHz, AV, Hori.	Complied
Note: UL Japan, Inc.'s EMI Work Procedures No. 13-EM-W0420 and 13-EM-W0422. *1) Radiated test was selected over 30 MHz based on section 15.247(d).					

* In case any questions arise about test procedure, ANSI C63.10: 2013 is also referred.

FCC Part 15.31 (e)

The RF Module has its own regulator.

The RF Module is constantly provided voltage (DC 3.3 V) through the regulator regardless of input voltage.
Therefore, this EUT complies with the requirement.

FCC Part 15.203/212 Antenna requirement

The EUT has a unique coupling/antenna connector (Connector Type: JSC).
Therefore the equipment complies with the requirement of 15.203.

UL Japan, Inc.

Ise EMC Lab.

4383-326 Asama-cho, Ise-shi, Mie-ken 516-0021 JAPAN

Telephone : +81 596 24 8999

Facsimile : +81 596 24 8124

3.3 Addition to standard

Item	Test Procedure	Specification	Worst margin	Results	Remarks
99% Occupied Bandwidth	IC: RSS-Gen 6.6	IC: -	N/A	-	Conducted

Other than above, no addition, exclusion nor deviation has been made from the standard.

3.4 Uncertainty

EMI

The following uncertainties have been calculated to provide a confidence level of 95 % using a coverage factor $k=2$.
Ise EMC Lab.

Antenna terminal test	Uncertainty (+/-)
RF output power	1.2 dB
Antenna terminal conducted emission / Power density / Burst power	3.1 dB
Adjacent channel power / Channel power	
Below 3 GHz	1.8 dB
3 GHz to 6 GHz	2.7 dB

Frequency range	Conducted emission using AMN(LISN) (+/-)
0.009 MHz - 0.15 MHz	3.1 dB
0.15 MHz - 30 MHz	2.5 dB

Test distance	Radiated emission (+/-) 9 kHz - 30 MHz
3 m	3.8 dB
10 m	3.6 dB

Polarity	Radiated emission (Below 1 GHz)			
	(3 m*) (+/-)		(10 m*) (+/-)	
	30 MHz - 200 MHz	200 MHz - 1000 MHz	30 MHz - 200 MHz	200 MHz - 1000 MHz
Horizontal	5.0 dB	5.3 dB	5.0 dB	5.0 dB
Vertical	5.2 dB	6.3 dB	5.0 dB	5.0 dB

Radiated emission (Above 1 GHz)				
	(3 m*) (+/-)	(1 m*) (+/-)		(10 m*) (+/-)
	1 GHz - 6 GHz	10 GHz - 26.5 GHz	26.5 GHz - 40 GHz	1 GHz - 18 GHz
	5.2 dB	5.5 dB	5.4 dB	5.5 dB

*Measurement distance

Conducted Emission test

The data listed in this test report has enough margin, more than the site margin.

Radiated emission test

The data listed in this test report has enough margin, more than the site margin.

UL Japan, Inc.

Ise EMC Lab.

4383-326 Asama-cho, Ise-shi, Mie-ken 516-0021 JAPAN

Telephone : +81 596 24 8999

Facsimile : +81 596 24 8124

3.5 Test Location

UL Japan, Inc. Ise EMC Lab. *NVLAP Lab. code: 200572-0
4383-326 Asama-cho, Ise-shi, Mie-ken 516-0021 JAPAN
Telephone: +81 596 24 8999, Facsimile: +81 596 24 8124

Test site	IC Registration Number	Width x Depth x Height (m)	Size of reference ground plane (m) / horizontal conducting plane	Other rooms	Maximum measurement distance
No.1 semi-anechoic chamber	2973C-1	19.2 x 11.2 x 7.7	7.0 x 6.0	No.1 Power source room	10 m
No.2 semi-anechoic chamber	2973C-2	7.5 x 5.8 x 5.2	4.0 x 4.0	-	3 m
No.3 semi-anechoic chamber	2973C-3	12.0 x 8.5 x 5.9	6.8 x 5.75	No.3 Preparation room	3 m
No.3 shielded room	-	4.0 x 6.0 x 2.7	N/A	-	-
No.4 semi-anechoic chamber	2973C-4	12.0 x 8.5 x 5.9	6.8 x 5.75	No.4 Preparation room	3 m
No.4 shielded room	-	4.0 x 6.0 x 2.7	N/A	-	-
No.5 semi-anechoic chamber	-	6.0 x 6.0 x 3.9	6.0 x 6.0	-	-
No.6 shielded room	-	4.0 x 4.5 x 2.7	4.0 x 4.5	-	-
No.6 measurement room	-	4.75 x 5.4 x 3.0	4.75 x 4.15	-	-
No.7 shielded room	-	4.7 x 7.5 x 2.7	4.7 x 7.5	-	-
No.8 measurement room	-	3.1 x 5.0 x 2.7	N/A	-	-
No.9 measurement room	-	8.8 x 4.6 x 2.8	2.4 x 2.4	-	-
No.11 measurement room	-	6.2 x 4.7 x 3.0	4.8 x 4.6	-	-

* Size of vertical conducting plane (for Conducted Emission test) : 2.0 m x 2.0 m for No.1, No.2, No.3, and No.4 semi-anechoic chambers and No.3 and No.4 shielded rooms.

3.6 Test data, Test instruments, and Test set up

Refer to APPENDIX.

UL Japan, Inc.

Ise EMC Lab.

4383-326 Asama-cho, Ise-shi, Mie-ken 516-0021 JAPAN

Telephone : +81 596 24 8999

Facsimile : +81 596 24 8124

SECTION 4: Operation of E.U.T. during testing

4.1 Operating Mode(s)

Bluetooth (BT): Transmitting (Tx), Payload: PRBS9

Details of Operating Mode(s)

Test Item	Mode	Tested frequency
Conducted Emission, Spurious Emission (Conducted/Radiated)	Tx (Hopping Off) DH5, 3DH5	2402 MHz 2441 MHz 2480 MHz
Carrier Frequency Separation	Tx (Hopping On) DH5, 3DH5	2402 MHz 2441 MHz 2480 MHz
20dB Bandwidth	Tx (Hopping Off) DH5, 3DH5	2402 MHz 2441 MHz 2480 MHz
Number of Hopping Frequency	Tx (Hopping On) DH5, 3DH5	-
Dwell time	Tx (Hopping On), -DH1, DH3, DH5 -3DH1, 3DH3, 3DH5	-
Maximum Peak Output Power	Tx (Hopping Off) DH5, 2DH5, 3DH5	2402 MHz 2441 MHz 2480 MHz
Band Edge Compliance (Conducted)	Tx DH5, 3DH5 -Hopping On -Hopping Off	2402 MHz 2480 MHz
99% Occupied Bandwidth	Tx DH5, 3DH5 -Hopping On -Hopping Off	2402 MHz 2441 MHz 2480 MHz
<p>*As a result of preliminary test, the formal test was performed with the above modes, which had the maximum payload length (except Dwell time test) *2DH mode (2Mb/s EDR: pi/4DQPSK) was excluded for other tests than power measurement by using 3DH mode (3 Mb/s EDR: 8DPSK) as a representative. * It is considered that the non-tested packet type (e.g. inquiry) can be omitted as it is complied with above all the test items based on Bluetooth Core specification.</p> <p>*EUT has the power settings by the software as follows; Power settings: Config:0218 Software: Bluetool 1.8.9.3 *This setting of software is the worst case. Any conditions under the normal use do not exceed the condition of setting. In addition, end users cannot change the settings of the output power of the product.</p>		

4.2 Configuration and peripherals

For Conducted Emission test

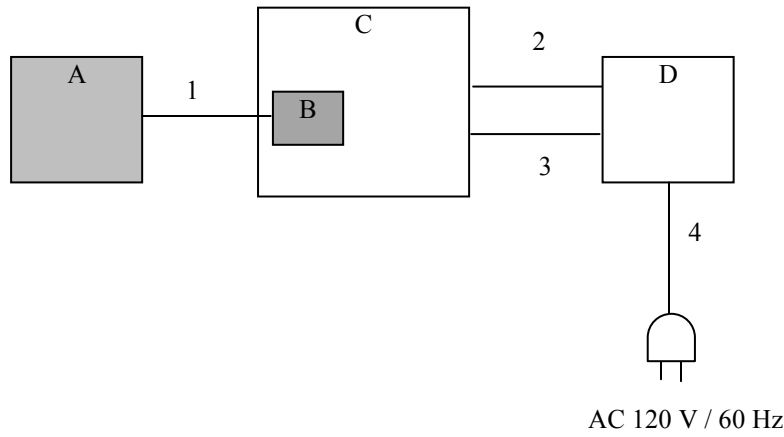

For all tests other than Conducted Emission test

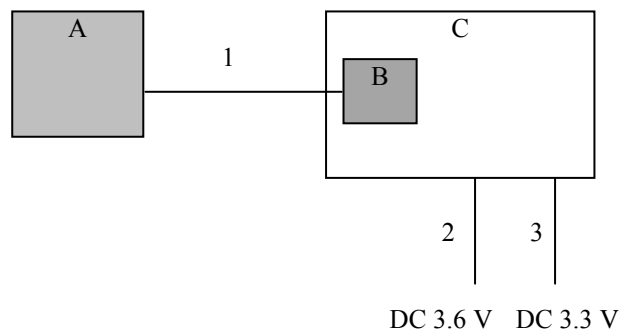

* Cabling and setup(s) were taken into consideration and test data was taken under worse case conditions.

Description of EUT and Support equipment

No.	Item	Model number	Serial number	Manufacturer	Remarks
A	Monopole pattern antenna	Type1KT-30	No.1	Murata Manufacturing Co., Ltd.	EUT *4)
B	Communication Module	1MW	46 *2) 45 *3)	Murata Manufacturing Co., Ltd.	EUT
C	Jig Board	1MW EVB ES1 P2ML5840	-	Murata Manufacturing Co., Ltd.	*5)
D	Regulated DC Power Supply	PW16-5ADP	171116437	TEXIO	-

List of cables used

No.	Name	Length (m)	Shield		Remarks
			Cable	Connector	
1	Signal Cable	0.03	Unshielded	Unshielded	*4)
2	DC Cable	0.5 *1) 2.5 *2)	Unshielded	Unshielded	-
3	DC Cable	0.5 *1) 2.5 *2)	Unshielded	Unshielded	-
4	AC Cable	1.00	Unshielded	Unshielded	-

*1) Used for Conducted Emission test

*2) Used for Radiated Emission test

*3) Used for Antenna Terminal Conducted test

*4) Used for all tests except for Antenna Terminal Conducted test

*5) The test was performed with the module that as normal assumed implementation conditions.
The use of a jig does not influence on the test result.

UL Japan, Inc.

Ise EMC Lab.

4383-326 Asama-cho, Ise-shi, Mie-ken 516-0021 JAPAN

Telephone : +81 596 24 8999

Facsimile : +81 596 24 8124

SECTION 5: Conducted Emission

Test Procedure and conditions

EUT was placed on a urethane platform of nominal size, 1.0 m by 1.5 m, raised 0.8 m above the conducting ground plane.

The rear of tabletop was located 40 cm to the vertical conducting plane. The rear of EUT, including peripherals aligned and flushed with rear of tabletop. All other surfaces of tabletop were at least 80 cm from any other grounded conducting surface. EUT was located 80 cm from a Line Impedance Stabilization Network (LISN) / Artificial mains Network (AMN) and excess AC cable was bundled in center.

1) For the tests on EUT with other peripherals (as a whole system)

I/O cables that were connected to the peripherals were bundled in center. They were folded back and forth forming a bundle 30 cm to 40 cm long and were hanged at a 40 cm height to the ground plane. All unused 50 ohm connectors of the LISN (AMN) were resistivity terminated in 50 ohm when not connected to the measuring equipment.

The AC Mains Terminal Continuous disturbance Voltage has been measured with the EUT in a Semi Anechoic Chamber.

The EUT was connected to a LISN (AMN).

An overview sweep with peak detection has been performed.

The test results and limit are rounded off to one decimal place, so some differences might be observed.

Detector : QP and CISPR AV
Measurement range : 0.15 MHz - 30 MHz
Test data : APPENDIX
Test result : Pass

SECTION 6: Radiated Spurious Emission

Test Procedure

[For below 1 GHz]

EUT was placed on a urethane platform of nominal size, 0.5 m by 1.0 m, raised 0.8 m above the conducting ground plane. The Radiated Electric Field Strength has been measured in a Semi Anechoic Chamber with a ground plane.

[For above 1 GHz]

EUT was placed on a urethane platform of nominal size, 0.5 m by 0.5 m, raised 1.5 m above the conducting ground plane.

The Radiated Electric Field Strength has been measured in a Semi Anechoic Chamber with absorbent materials lined on a ground plane.

The height of the measuring antenna varied between 1 and 4 m and EUT was rotated a full revolution in order to obtain the maximum value of the electric field strength.

The measurements were performed for both vertical and horizontal antenna polarization with the Test Receiver, or the Spectrum Analyzer.

The measurements were made with the following detector function of the test receiver and the Spectrum analyzer (in linear mode).

The test was made with the detector (RBW/VBW) in the following table.

When using Spectrum analyzer, the test was made with adjusting span to zero by using peak hold.

Test Antennas are used as below;

Frequency	30 MHz to 200 MHz	200 MHz to 1 GHz	Above 1 GHz
Antenna Type	Biconical	Logperiodic	Horn

In any 100 kHz bandwidth outside the restricted band in which the spread spectrum intentional radiator is operating, the radio frequency power that is produced by the intentional radiator confirmed 20 dB below that in the 100 kHz bandwidth within the band that contains the highest level of the desired power, based on a radiated measurement.

20 dBc was applied to the frequency over the limit of FCC 15.209 / Table 4 of RSS-Gen 8.9 (IC) and outside the restricted band of FCC15.205 / Table 6 of RSS-Gen 8.10 (IC).

Frequency	Below 1 GHz	Above 1 GHz		20 dBc
Instrument used	Test Receiver	Spectrum Analyzer		Spectrum Analyzer
Detector	QP	PK	AV	PK
IF Bandwidth	BW 120 kHz	RBW: 1 MHz VBW: 3 MHz	RBW: 1 MHz VBW: 10 Hz *1)	RBW: 100 kHz VBW: 300 kHz
Test Distance	3 m	3.75 m*2) (1 GHz – 10 GHz), 1.0 m*3) (10 GHz – 26.5 GHz)		3.75 m*2) (1 GHz – 10 GHz), 1 m*3) (10 GHz – 26.5 GHz)

*1) Although DA 00-705 accepts VBW = 10 Hz for AV measurements, it was confirmed that superfluous smoothing was not performed.

*2) Distance Factor: $20 \times \log(3.75 \text{ m}/3.0 \text{ m}) = 1.94 \text{ dB}$

*3) Distance Factor: $20 \times \log(1.0 \text{ m}/3.0 \text{ m}) = -9.5 \text{ dB}$

- The carrier level and noise levels were confirmed at each position of X, Y and Z axes of EUT (Antenna and Module) to see the position of maximum noise, and the test was made at the position that has the maximum noise.

The test results and limit are rounded off to one decimal place, so some differences might be observed.

Measurement range : 30 MHz - 26.5 GHz

Test data : APPENDIX

Test result : Pass

UL Japan, Inc.

Ise EMC Lab.

4383-326 Asama-cho, Ise-shi, Mie-ken 516-0021 JAPAN

Telephone : +81 596 24 8999

Facsimile : +81 596 24 8124

SECTION 7: Antenna Terminal Conducted Tests

Test Procedure

The tests were made with below setting connected to the antenna port.

Test	Span	RBW	VBW	Sweep time	Detector	Trace	Instrument used
20dB Bandwidth	3 MHz	30 kHz	100 kHz	Auto	Peak	Max Hold	Spectrum Analyzer
99% Occupied Bandwidth *1)	Enough width to display emission skirts	1 to 5 % of OBW	Three times of RBW	Auto	Peak	Max Hold	Spectrum Analyzer
Maximum Peak Output Power	-	-	-	Auto	Peak Average *2)	-	Power Meter (Sensor: 50MHz BW)
Carrier Frequency Separation	3 MHz	30 kHz	100 kHz	Auto	Peak	Max Hold	Spectrum Analyzer
Number of Hopping Frequency	30 MHz	300 kHz	1 MHz	Auto	Peak	Max Hold	Spectrum Analyzer
Dwell Time	Zero Span	100 kHz, 1 MHz	300 kHz, 3 MHz	As necessary capture the entire dwell time per hopping channel	Peak	Clear Write	Spectrum Analyzer
Conducted Spurious Emission *3)	9 kHz to 150 kHz	200 Hz	620 Hz	Auto	Peak	Max Hold	Spectrum Analyzer
	150 kHz to 30 MHz	9.1 kHz	27 kHz				
	30 MHz to 25 GHz	100 kHz	300 kHz				
Conducted Spurious Emission Band Edge compliance	10 MHz	100 kHz	300 kHz	Auto	Peak	Max Hold	Spectrum Analyzer

*1) Peak hold was applied as Worst-case measurement.

*2) Reference data

*3) In the frequency range below 30MHz, RBW was narrowed to separate the noise contents.

Then, wide-band noise near the limit was checked separately, however the noise was low enough as shown in the chart.

(9 kHz - 150 kHz: RBW = 200Hz, 150 kHz - 30 MHz: RBW = 9.1 kHz).

The test results and limit are rounded off to two decimals place, so some differences might be observed.

Test data : APPENDIX
Test result : Pass

APPENDIX 1: Test data

Conducted Emission

DATA OF CONDUCTED EMISSION TEST

UL Japan, Inc. Ise EMC Lab. No.3 Semi Anechoic Chamber
Date : 2017/07/20

Report No. 11774441H

Temp./Humi. : 24deg. C / 56% RH
Engineer : Tomoki Matsui

Mode / Remarks : Tx DH5 2402MHz

LIMIT : FCC15.207 QP
FCC15.207 AV

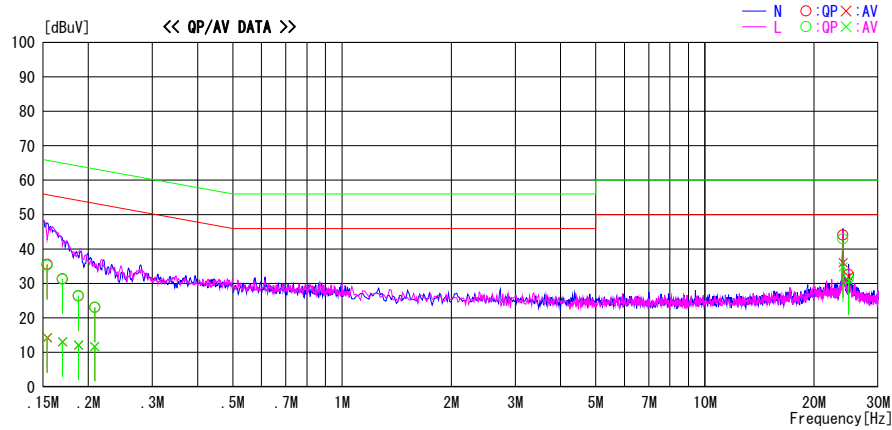

Frequency [MHz]	Reading Level		Corr. Factor [dB]	Results		Limit		Margin		Phase	Comment
	QP [dBuV]	AV [dBuV]		QP [dBuV]	AV [dBuV]	QP [dBuV]	AV [dBuV]	QP [dB]	AV [dB]		
0.15408	22.5	1.2	13.1	35.6	14.3	65.8	55.8	30.2	41.5	N	
0.16983	18.1	-0.1	13.2	31.3	13.1	65.0	55.0	33.7	41.9	N	
0.18792	13.3	-1.0	13.1	26.4	12.1	64.1	54.1	37.7	42.0	N	
0.20833	9.8	-1.5	13.2	23.0	11.7	63.3	53.3	40.3	41.6	N	
24.00081	29.5	21.4	14.6	44.1	36.0	60.0	50.0	15.9	14.0	N	
24.87749	18.0	17.4	14.6	32.6	32.0	60.0	50.0	27.4	18.0	N	
0.15408	22.2	1.0	13.1	35.3	14.1	65.8	55.8	30.5	41.7	L	
0.16983	18.0	-0.2	13.2	31.2	13.0	65.0	55.0	33.8	42.0	L	
0.18792	13.3	-1.0	13.2	26.5	12.2	64.1	54.1	37.6	41.9	L	
0.20833	9.8	-1.5	13.2	23.0	11.7	63.3	53.3	40.3	41.6	L	
24.00057	28.3	20.2	14.6	42.9	34.8	60.0	50.0	17.1	15.2	L	
24.87729	16.9	16.3	14.6	31.5	30.9	60.0	50.0	28.5	19.1	L	

CHART: WITH FACTOR Peak hold data. CALCULATION : RESULT = READING + C.F (LISN + CABLE + ATTEN)
Except for the above table: adequate margin data below the limits.

Conducted Emission

Test place	Ise EMC Lab. No.3 Semi Anechoic Chamber
Report No.	11774441H
Date	July 20, 2017
Temperature / Humidity	24 deg. C / 56 % RH
Engineer	Tomoki Matsui
Mode	Tx, Hopping Off, DH5

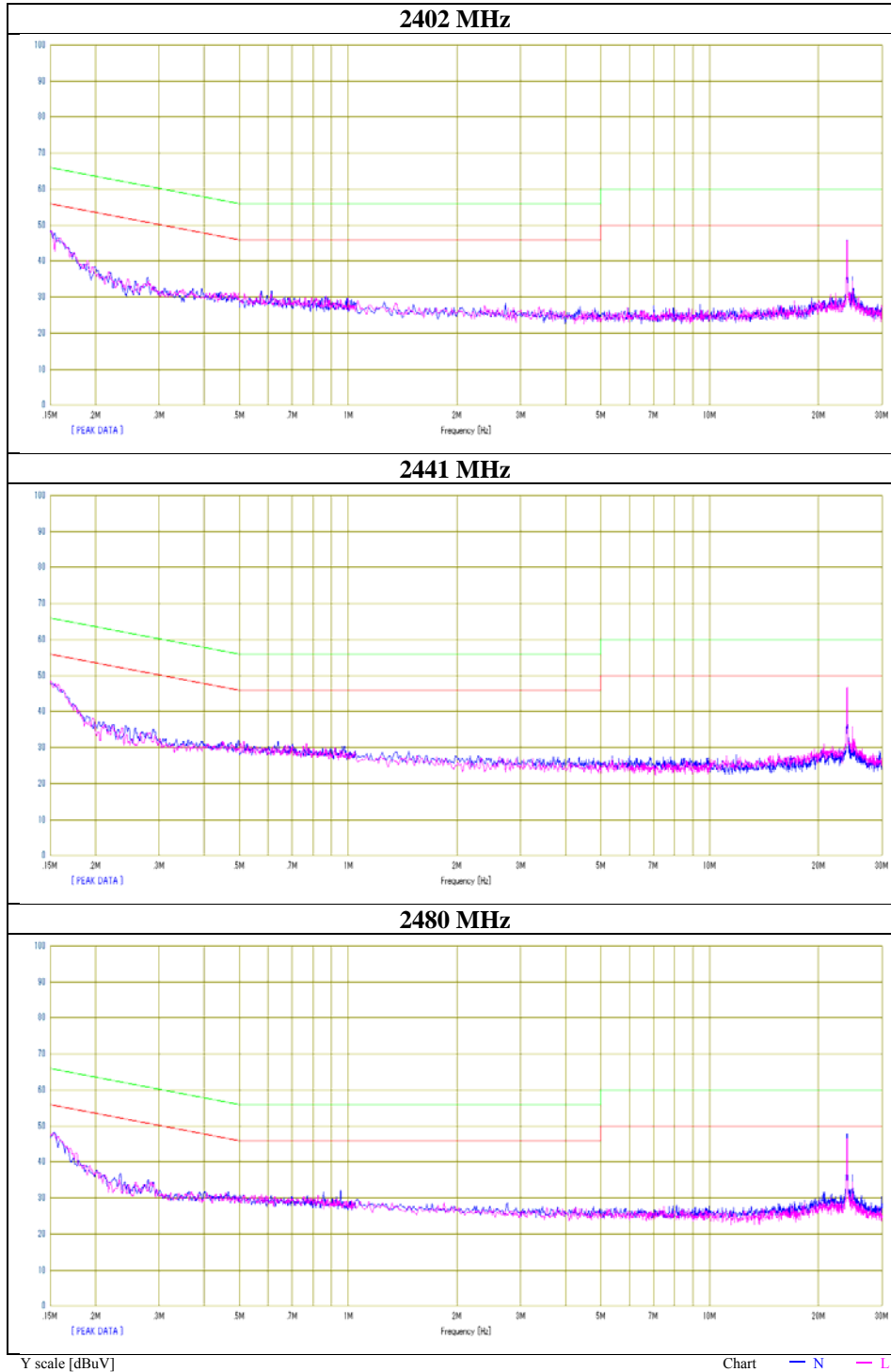

UL Japan, Inc.

Ise EMC Lab.

4383-326 Asama-cho, Ise-shi, Mie-ken 516-0021 JAPAN

Telephone : +81 596 24 8999

Facsimile : +81 596 24 8124

Conducted Emission

DATA OF CONDUCTED EMISSION TEST

UL Japan, Inc. Ise EMC Lab. No.3 Semi Anechoic Chamber
Date : 2017/07/20

Report No. : 11774441H

Temp./Humi. : 24deg. C / 56% RH
Engineer : Tomoki Matsui

Mode / Remarks : Tx 3DH5 2402MHz

LIMIT : FCC15.207 QP
FCC15.207 AV

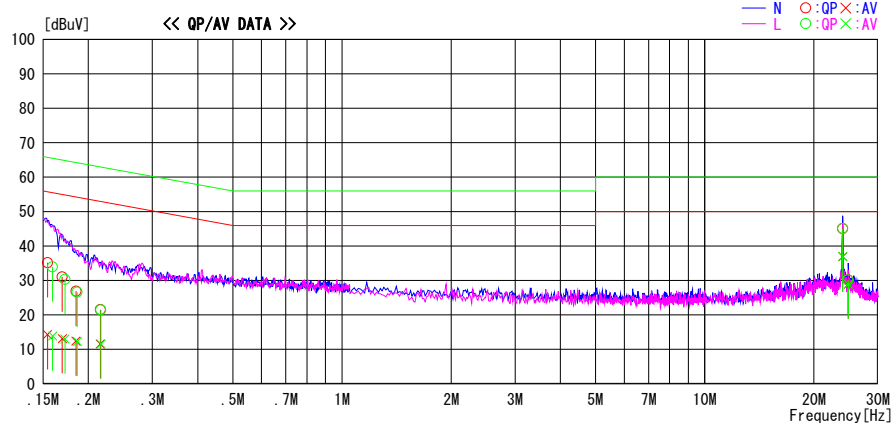

Frequency [MHz]	Reading Level		Corr. Factor [dB]	Results		Limit		Margin		Phase	Comment
	QP [dBuV]	AV [dBuV]		QP [dBuV]	AV [dBuV]	QP [dBuV]	AV [dBuV]	QP [dB]	AV [dB]		
0.15429	22.0	1.1	13.2	35.2	14.3	65.8	55.8	30.6	41.5	N	
0.16939	17.8	-0.1	13.2	31.0	13.1	65.0	55.0	34.0	41.9	N	
0.18491	13.7	-0.8	13.2	26.9	12.4	64.3	54.3	37.4	41.9	N	
0.21562	8.3	-1.6	13.2	21.5	11.6	63.0	53.0	41.5	41.4	N	
24.00017	30.5	22.3	14.6	45.1	36.9	60.0	50.0	14.9	13.1	N	
24.87777	15.5	14.4	14.6	30.1	29.0	60.0	50.0	29.9	21.0	N	
0.15933	20.8	0.7	13.2	34.0	13.9	65.5	55.5	31.5	41.6	L	
0.17217	17.1	-0.2	13.2	30.3	13.0	64.9	54.9	34.6	41.9	L	
0.18617	13.4	-0.9	13.2	26.6	12.3	64.2	54.2	37.6	41.9	L	
0.21650	8.2	-1.6	13.2	21.4	11.6	63.0	53.0	41.6	41.4	L	
24.00037	30.5	22.3	14.6	45.1	36.9	60.0	50.0	14.9	13.1	L	
24.87777	15.5	14.4	14.6	30.1	29.0	60.0	50.0	29.9	21.0	L	

CHART: WITH FACTOR, Peak hold data. CALCULATION: RESULT = READING + C.F(LISN + ATTN + CABLE)
Except for the above table : adequate margin data below the limits.

Conducted Emission

Test place	Ise EMC Lab. No.3 Semi Anechoic Chamber
Report No.	11774441H
Date	July 20, 2017
Temperature / Humidity	24 deg. C / 56 % RH
Engineer	Tomoki Matsui
Mode	Tx, Hopping Off, 3DH5

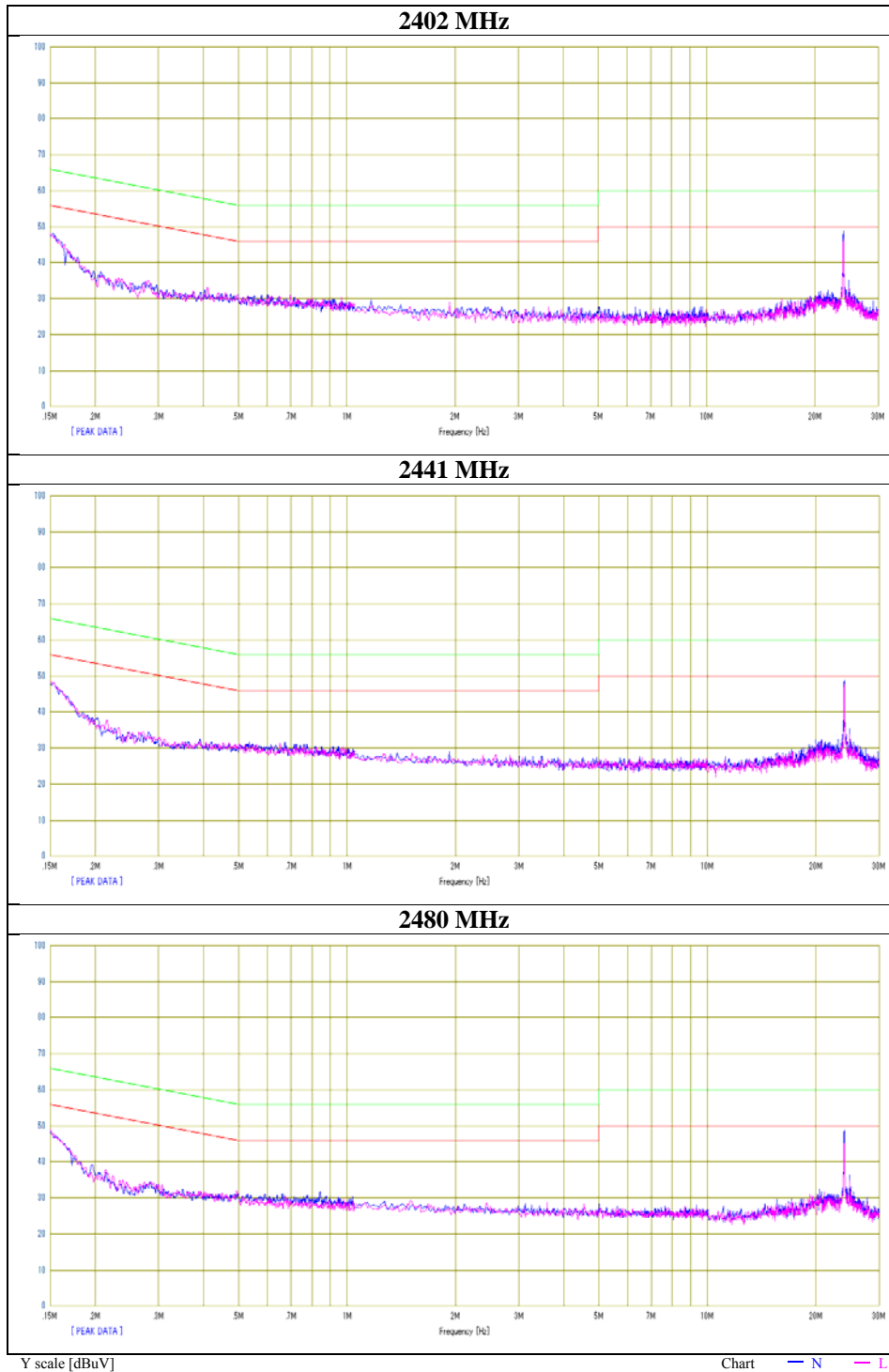

UL Japan, Inc.

Ise EMC Lab.

4383-326 Asama-cho, Ise-shi, Mie-ken 516-0021 JAPAN

Telephone : +81 596 24 8999

Facsimile : +81 596 24 8124

20dB Bandwidth and Carrier Frequency Separation

Test place : Ise EMC Lab. No.6 Measurement Room
Report No. : 11774441H
Date : July 14, 2017
Temperature / Humidity : 25 deg. C / 58 % RH
Engineer : Takumi Shimada
Mode : Tx, Hopping Off, DH5

Mode	Freq. [MHz]	20dB Bandwidth [MHz]	Carrier Frequency Separation [MHz]	Limit for Carrier Frequency separation [MHz]
DH5	2402.0	0.995	1.000	≥ 0.663
DH5	2441.0	0.955	1.000	≥ 0.637
DH5	2480.0	0.989	1.000	≥ 0.659
3DH5	2402.0	1.317	1.000	≥ 0.878
3DH5	2441.0	1.318	1.000	≥ 0.879
3DH5	2480.0	1.331	1.000	≥ 0.887

Limit: Two-thirds of 20dB Bandwidth or 25kHz (whichever is greater).
No limit applies to 20dB Bandwidth.

20dB Bandwidth and Carrier Frequency Separation

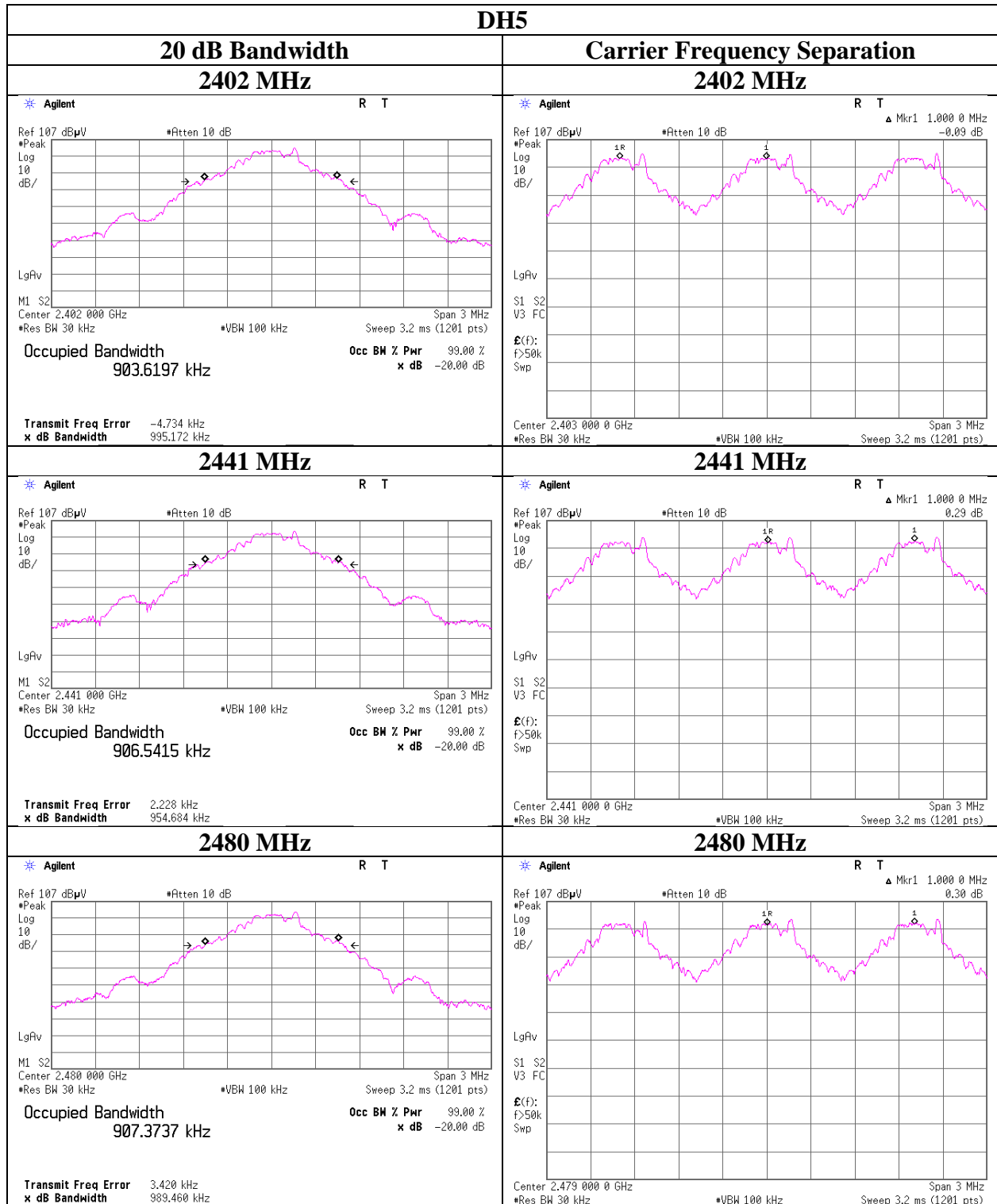

UL Japan, Inc.

Ise EMC Lab.

4383-326 Asama-cho, Ise-shi, Mie-ken 516-0021 JAPAN

Telephone : +81 596 24 8999

Facsimile : +81 596 24 8124

20dB Bandwidth and Carrier Frequency Separation

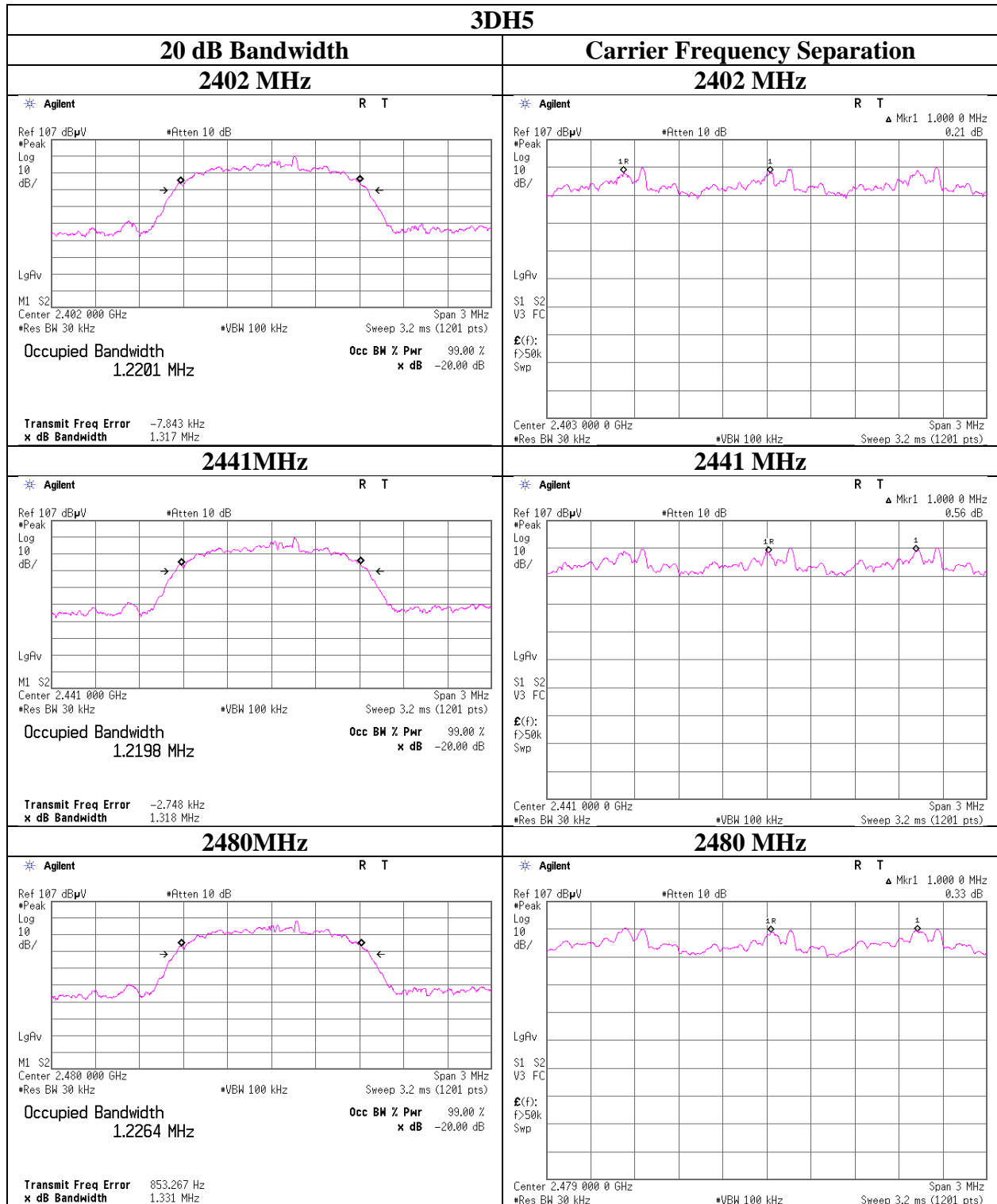

UL Japan, Inc.

Ise EMC Lab.

4383-326 Asama-cho, Ise-shi, Mie-ken 516-0021 JAPAN

Telephone : +81 596 24 8999

Facsimile : +81 596 24 8124

Number of Hopping Frequency

Test place Ise EMC Lab. No.6 Measurement Room
Report No. 11774441H
Date July 14, 2017
Temperature / Humidity 25 deg. C / 58 % RH
Engineer Takumi Shimada
Mode Tx, Hopping On

Mode	Number of channel [channels]	Limit [channels]
DH5	79	≥ 15
3DH5	79	≥ 15

Test was not performed at AFH mode whose number of hopping channel is 20 channels because this Bluetooth radio is in compliance of Bluetooth Specification.

Number of Hopping Frequency

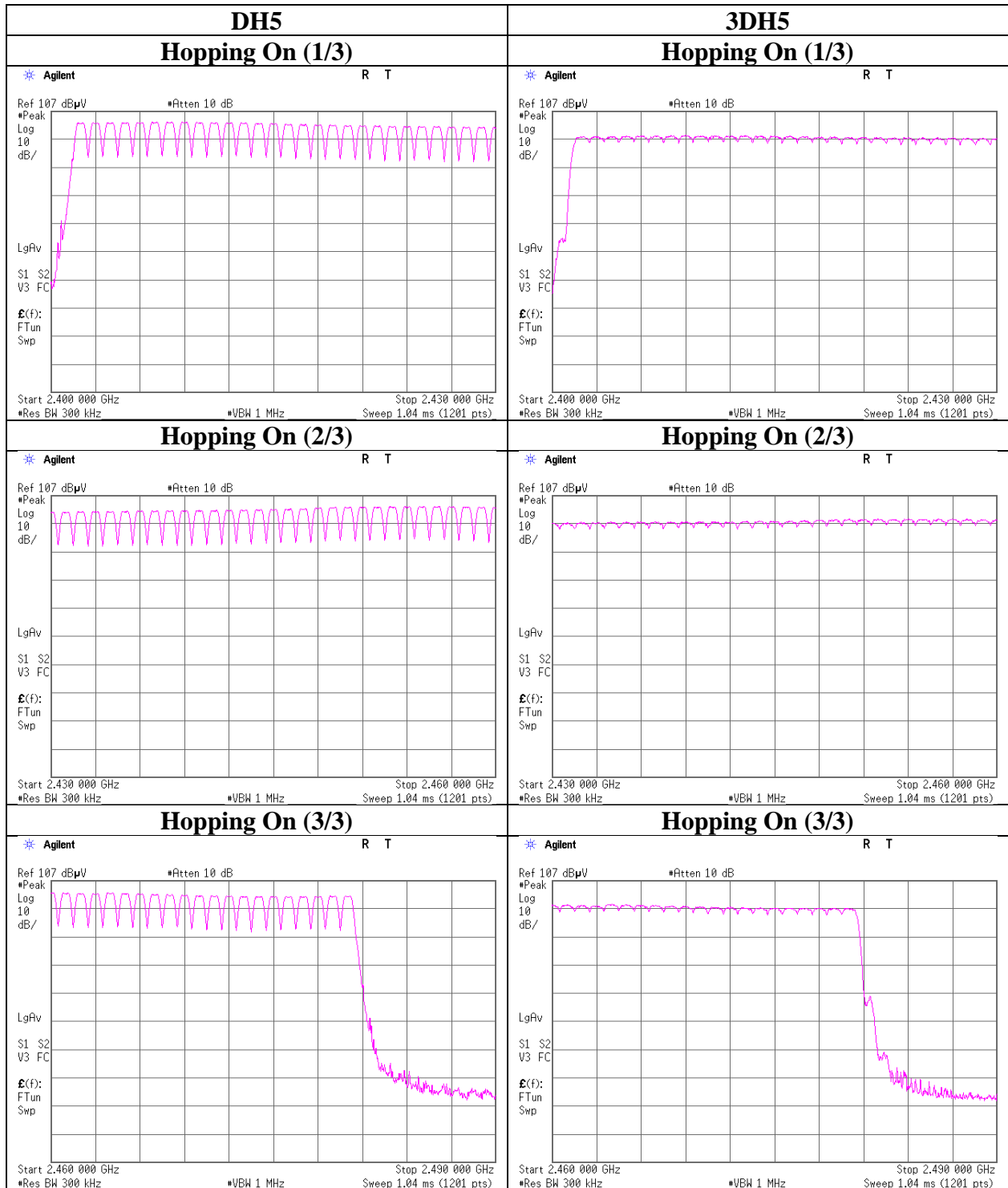

UL Japan, Inc.

Ise EMC Lab.

4383-326 Asama-cho, Ise-shi, Mie-ken 516-0021 JAPAN

Telephone : +81 596 24 8999

Facsimile : +81 596 24 8124

Dwell time

Test place : Ise EMC Lab. No.6 Measurement Room
Report No. : 11774441H
Date : July 14, 2017
Temperature / Humidity : 25 deg. C / 58 % RH
Engineer : Takumi Shimada
Mode : Tx, Hopping On

Mode	Number of transmission in a 31.6(79 Hopping x 0.4) / 12.8 (32 Hopping x 0.4) second period				Length of transmission [msec]	Result [msec]	Limit [msec]
	47.8 times / 5 sec.	x	31.6 sec. =	303 times			
DH1	47.8 times / 5 sec.	x	31.6 sec. =	303 times	0.423	128	400
DH3	25.6 times / 5 sec.	x	31.6 sec. =	162 times	1.692	274	400
DH5	20.4 times / 5 sec.	x	31.6 sec. =	129 times	2.944	380	400
3DH1	44.8 times / 5 sec.	x	31.6 sec. =	284 times	0.431	122	400
3DH3	24.2 times / 5 sec.	x	31.6 sec. =	153 times	1.690	259	400
3DH5	19.4 times / 5 sec.	x	31.6 sec. =	123 times	2.944	362	400

Sample Calculation

Result = Number of transmission x Length of transmission

*Average data of 5 tests.(except Inquiry)

Mode	Sampling [times]					Average [times]
	1	2	3	4	5	
DH1	47	50	48	47	47	47.8
DH3	30	23	25	26	24	25.6
DH5	23	19	19	20	21	20.4
3DH1	43	46	45	46	44	44.8
3DH3	25	25	24	21	26	24.2
3DH5	20	22	18	20	17	19.4

Sample Calculation

Average = Summation (Sampling 1 to 5) / 5

This device complies with the Bluetooth protocol for FHSS operation, employing a pseudo random channel selection and hopping rate to ensure that the occupancy time in $N \times 0.4s$, where N is the number of channels being used in the hopping sequence ($20 \leq N \leq 79$), is always less than $0.4s$ regardless of packet size. This is confirmed in the test report for $N = 79$.

Dwell time

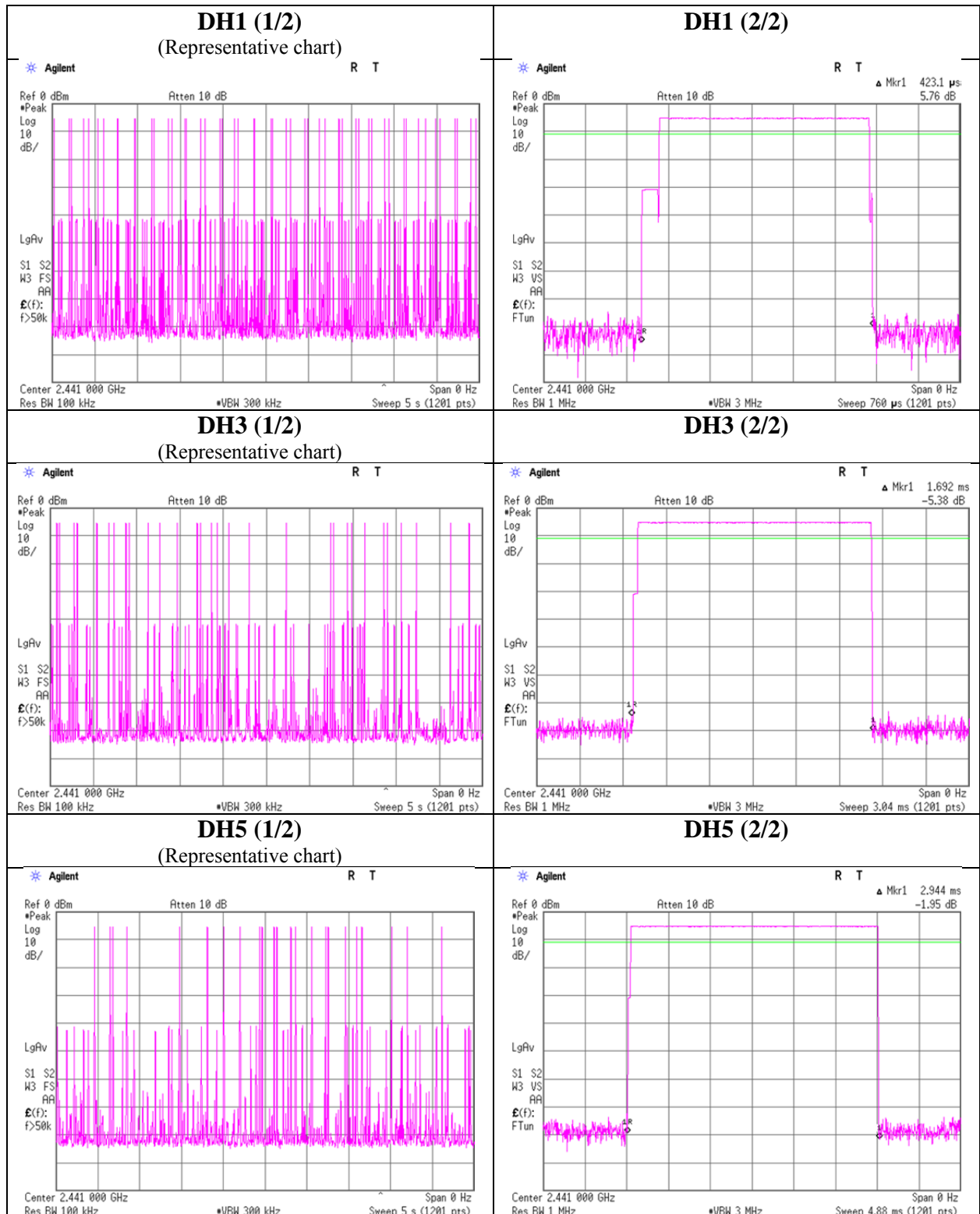

UL Japan, Inc.

Ise EMC Lab.

4383-326 Asama-cho, Ise-shi, Mie-ken 516-0021 JAPAN

Telephone : +81 596 24 8999

Facsimile : +81 596 24 8124

Dwell time

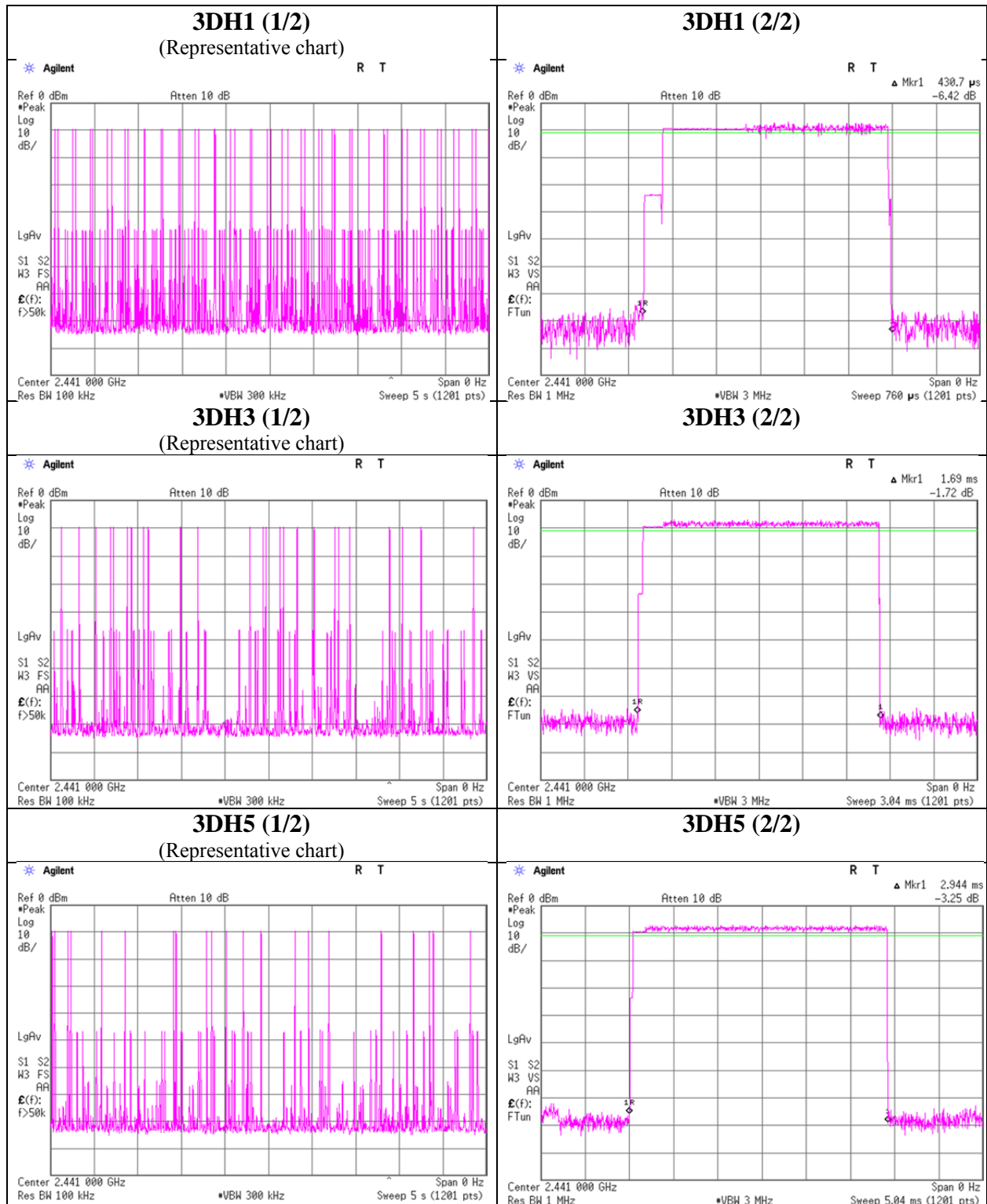

UL Japan, Inc.

Ise EMC Lab.

4383-326 Asama-cho, Ise-shi, Mie-ken 516-0021 JAPAN

Telephone : +81 596 24 8999

Facsimile : +81 596 24 8124

Maximum Peak Output Power

Test place : Ise EMC Lab. No.6 Measurement Room
Report No. : 11774441H
Date : July 13, 2017
Temperature / Humidity : 24 deg. C / 58 % RH
Engineer : Takafumi Noguchi
Mode : Tx, Hopping Off

Mode	Freq. [MHz]	Reading [dBm]	Cable Loss [dB]	Atten. Loss [dB]	Result		Limit		Margin [dB]
					[dBm]	[mW]	[dBm]	[mW]	
DH5	2402.0	-3.91	0.80	10.19	7.08	5.11	20.96	125	13.88
DH5	2441.0	-4.92	0.80	10.19	6.07	4.05	20.96	125	14.89
DH5	2480.0	-5.14	0.80	10.20	5.86	3.85	20.96	125	15.10
2DH5	2402.0	-6.31	0.80	10.19	4.68	2.94	20.96	125	16.28
2DH5	2441.0	-6.63	0.80	10.19	4.36	2.73	20.96	125	16.60
2DH5	2480.0	-7.11	0.80	10.20	3.89	2.45	20.96	125	17.07
3DH5	2402.0	-6.22	0.80	10.19	4.77	3.00	20.96	125	16.19
3DH5	2441.0	-6.53	0.80	10.19	4.46	2.79	20.96	125	16.50
3DH5	2480.0	-7.03	0.80	10.20	3.97	2.49	20.96	125	16.99

Sample Calculation:

Result = Reading + Cable Loss (including the cable(s) customer supplied) + Attenuator Loss

*The equipment and cables were not used for factor 0 dB of the data sheets.

As this device had AFH mode and frequency separation could not meet the requirement of over 20dB BW without 2/3 relaxation, 125mW power limit was applied to it.

Average Output Power
(Reference data for RF Exposure / SAR testing)

Test place : Ise EMC Lab. No.6 Measurement Room
Report No. : 11774441H
Date : July 13, 2017
Temperature / Humidity : 24 deg. C / 58 % RH
Engineer : Takafumi Noguchi
Mode : Tx, Hopping Off

Mode	Freq. [MHz]	Reading [dBm]	Cable Loss [dB]	Atten. Loss [dB]	Result (Time average)		Duty factor [dB]	Result (Burst power average)	
					[dBm]	[mW]		[dBm]	[mW]
DH5	2402.0	-5.20	0.80	10.19	5.79	3.79	1.07	6.86	4.85
DH5	2441.0	-6.21	0.80	10.19	4.78	3.01	1.07	5.85	3.85
DH5	2480.0	-6.42	0.80	10.20	4.58	2.87	1.07	5.65	3.67
2DH5	2402.0	-10.04	0.80	10.19	0.95	1.24	1.08	2.03	1.60
2DH5	2441.0	-10.30	0.80	10.19	0.69	1.17	1.08	1.77	1.50
2DH5	2480.0	-10.82	0.80	10.20	0.18	1.04	1.08	1.26	1.34
3DH5	2402.0	-10.01	0.80	10.19	0.98	1.25	1.06	2.04	1.60
3DH5	2441.0	-10.27	0.80	10.19	0.72	1.18	1.06	1.78	1.51
3DH5	2480.0	-10.79	0.80	10.20	0.21	1.05	1.06	1.27	1.34

Sample Calculation:

Result (Time average) = Reading + Cable Loss (including the cable(s) customer supplied) + Attenuator Loss

Result (Burst power average) = Time average + Duty factor

*The equipment and cables were not used for factor 0 dB of the data sheets.

Burst Rate Confirmation

Test place	Ise EMC Lab. No.11 Measurement Room	
Report No.	11774441H	
Date	June 29, 2017	July 13, 2017
Temperature / Humidity	24 deg. C / 65 % RH	24 deg. C / 58 % RH
Engineer	Takumi Shimada	Takafumi Noguchi
Mode	Tx, Hopping Off	

DH5

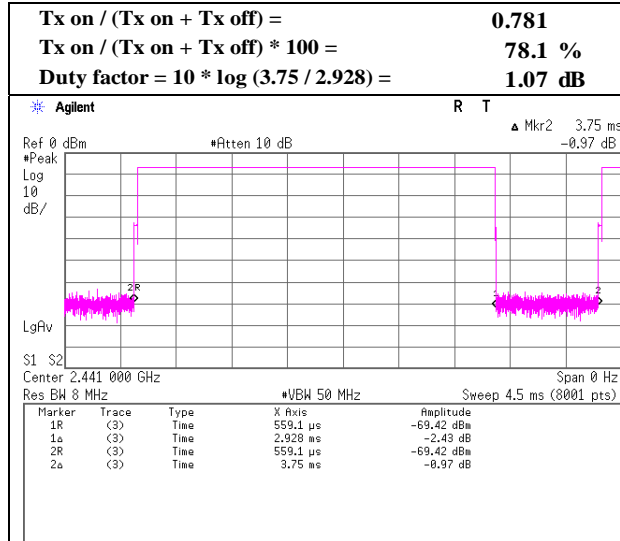

2DH5

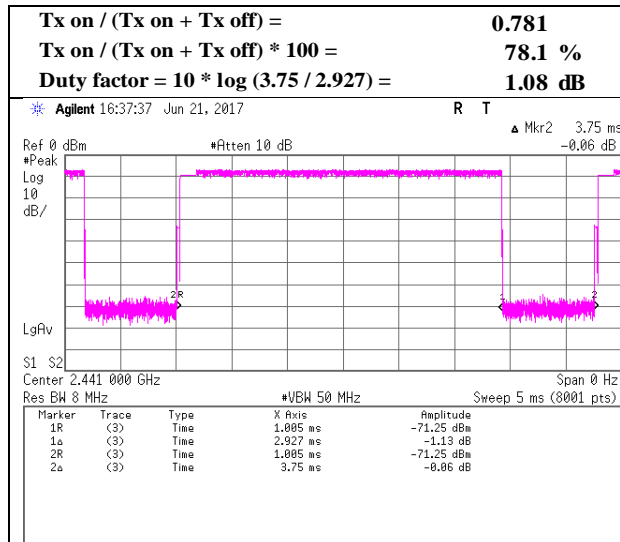

3DH5

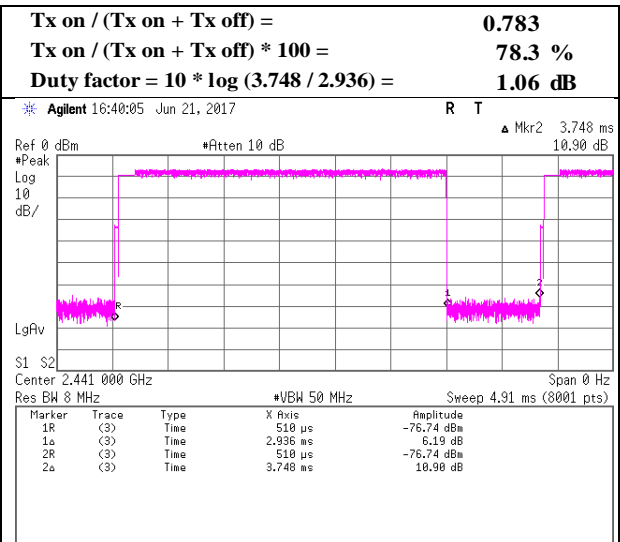

Radiated Spurious Emission

Report No. 11774441H
Test place Ise EMC Lab.
Semi Anechoic Chamber No.2 No.2 No.2
Date July 12, 2017 July 14, 2017 July 15, 2017
Temperature / Humidity 22 deg. C / 66 % RH 21 deg. C / 57 % RH 23 deg. C / 65 % RH
Engineer Tomoki Matsui Masafumi Niwa Takumi Shimada
(1 GHz -10 GHz) (10 GHz -26.5 GHz) (30 MHz -1000 MHz)
Mode Tx, Hopping Off, DH5 2402 MHz

Polarity	Frequency [MHz]	Detector	Reading [dBuV]	Ant.Fac. [dB/m]	Loss [dB]	Gain [dB]	Result [dBuV/m]	Limit [dBuV/m]	Margin [dB]	Remark
Hori	40.000	QP	24.6	14.1	6.8	28.2	17.3	40.0	22.7	Floor noise
Hori	100.000	QP	25.9	10.1	7.4	28.0	15.4	43.5	28.1	Floor noise
Hori	150.000	QP	23.9	14.8	7.8	27.8	18.7	43.5	24.8	Floor noise
Hori	300.000	QP	23.0	13.4	8.8	27.2	18.0	46.0	28.0	Floor noise
Hori	500.000	QP	23.6	17.7	9.8	28.1	23.0	46.0	23.0	Floor noise
Hori	700.000	QP	22.8	19.8	10.5	27.6	25.5	46.0	20.5	Floor noise
Hori	2390.000	PK	43.9	27.0	4.9	34.6	41.2	73.9	32.7	
Hori	4804.000	PK	42.6	31.3	7.6	33.8	47.7	73.9	26.2	Floor noise
Hori	7206.000	PK	41.6	35.6	8.4	33.9	51.7	73.9	22.2	Floor noise
Hori	9608.000	PK	43.4	38.2	9.3	34.5	56.4	73.9	17.5	Floor noise
Hori	2390.000	AV	31.7	27.0	4.9	34.6	29.0	53.9	24.9	
Hori	4804.000	AV	29.8	31.3	7.6	33.8	34.9	53.9	19.0	Floor noise
Hori	7206.000	AV	29.8	35.6	8.4	33.9	39.9	53.9	14.0	Floor noise
Hori	9608.000	AV	30.0	38.2	9.3	34.5	43.0	53.9	10.9	Floor noise
Vert	40.000	QP	24.5	14.1	6.8	28.2	17.2	40.0	22.8	Floor noise
Vert	100.000	QP	24.6	10.1	7.4	28.0	14.1	43.5	29.4	Floor noise
Vert	150.000	QP	23.8	14.8	7.8	27.8	18.6	43.5	24.9	Floor noise
Vert	300.000	QP	23.1	13.4	8.8	27.2	18.1	46.0	27.9	Floor noise
Vert	500.000	QP	23.6	17.7	9.8	28.1	23.0	46.0	23.0	Floor noise
Vert	700.000	QP	22.9	19.8	10.5	27.6	25.6	46.0	20.4	Floor noise
Vert	2390.000	PK	44.1	27.0	4.9	34.6	41.4	73.9	32.5	
Vert	4804.000	PK	42.6	31.3	7.6	33.8	47.7	73.9	26.2	Floor noise
Vert	7206.000	PK	41.6	35.6	8.4	33.9	51.7	73.9	22.2	Floor noise
Vert	9608.000	PK	43.4	38.2	9.3	34.5	56.4	73.9	17.5	Floor noise
Vert	2390.000	AV	31.6	27.0	4.9	34.6	28.9	53.9	25.0	
Vert	4804.000	AV	29.8	31.3	7.6	33.8	34.9	53.9	19.0	Floor noise
Vert	7206.000	AV	29.8	35.6	8.4	33.9	39.9	53.9	14.0	Floor noise
Vert	9608.000	AV	30.0	38.2	9.3	34.5	43.0	53.9	10.9	Floor noise

Result = Reading + Ant Factor + Loss (Cable+Attenuator+Filter+Distance factor(above 1 GHz)) - Gain(Amplifier)

*Other frequency noises omitted in this report were not seen or had enough margin (more than 20 dB).

Distance factor: 1 GHz - 10 GHz 20log (3.75 m / 3.0 m) = 1.94 dB

10 GHz - 26.5 GHz 20log (1.0 m / 3.0 m) = -9.5 dB

20dBc Data Sheet

Polarity	Frequency [MHz]	Detector	Reading [dBuV]	Ant Factor [dB/m]	Loss [dB]	Gain [dB]	Result [dBuV/m]	Limit [dBuV/m]	Margin [dB]	Remark
Hori	2402.000	PK	103.2	27.0	5.0	34.6	100.6	-	-	Carrier
Hori	2400.000	PK	44.0	27.0	5.0	34.6	41.4	80.6	39.2	
Vert	2402.000	PK	99.2	27.0	5.0	34.6	96.6	-	-	Carrier
Vert	2400.000	PK	40.7	27.0	5.0	34.6	38.1	76.6	38.5	

Result = Reading + Ant Factor + Loss (Cable+Attenuator+Filter+Distance factor(above 1 GHz)) - Gain(Amplifier)

***These results have sufficient margin without taking account Dwell time factor.**

UL Japan, Inc.

Ise EMC Lab.

4383-326 Asama-cho, Ise-shi, Mie-ken 516-0021 JAPAN

Telephone : +81 596 24 8999

Facsimile : +81 596 24 8124

Radiated Spurious Emission
(Reference Plot for band-edge)

Report No. 11774441H
Test place Ise EMC Lab.
Semi Anechoic Chamber No.2
Date July 12, 2017
Temperature / Humidity 22 deg. C / 66 % RH
Engineer Tomoki Matsui
(1 GHz -10 GHz)
Mode Tx, Hopping Off, DH5 2402 MHz

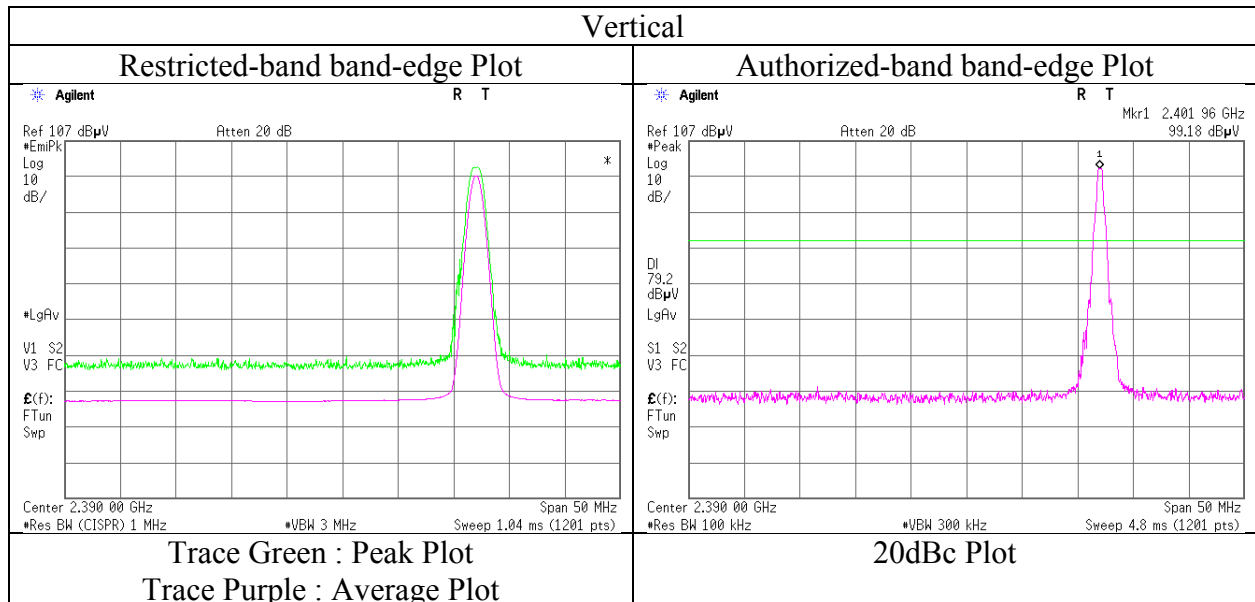
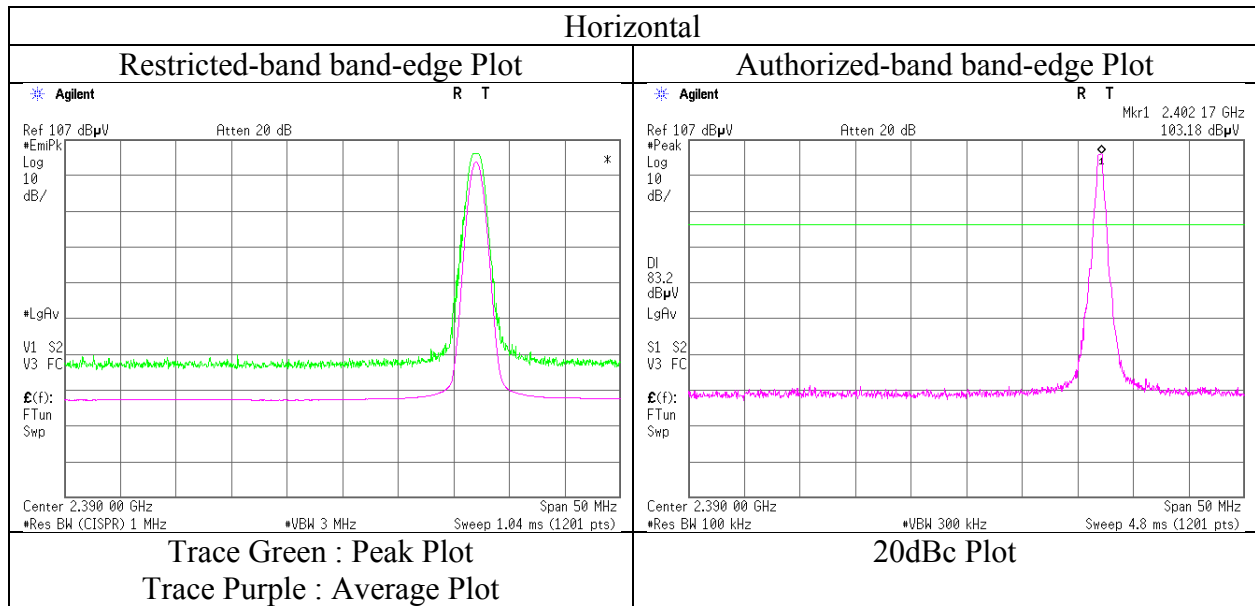

* Final result of restricted band edge was shown in tabular data.

Radiated Spurious Emission

Report No. 11774441H
Test place Ise EMC Lab.
Semi Anechoic Chamber No.2 No.2 No.2
Date July 12, 2017 July 14, 2017 July 15, 2017
Temperature / Humidity 22 deg. C / 66 % RH 21 deg. C / 57 % RH 23 deg. C / 65 % RH
Engineer Tomoki Matsui Masafumi Niwa Takumi Shimada
(1 GHz -10 GHz) (10 GHz -26.5 GHz) (30 MHz -1000 MHz)
Mode Tx, Hopping Off, DH5 2441 MHz

Polarity	Frequency [MHz]	Detector	Reading [dBuV]	Ant.Fac. [dB/m]	Loss [dB]	Gain [dB]	Result [dBuV/m]	Limit [dBuV/m]	Margin [dB]	Remark
Hori	40.000	QP	24.6	14.1	6.8	28.2	17.3	40.0	22.7	Floor noise
Hori	100.000	QP	25.7	10.1	7.4	28.0	15.2	43.5	28.3	Floor noise
Hori	150.000	QP	23.9	14.8	7.8	27.8	18.7	43.5	24.8	Floor noise
Hori	300.000	QP	23.1	13.4	8.8	27.2	18.1	46.0	27.9	Floor noise
Hori	500.000	QP	23.6	17.7	9.8	28.1	23.0	46.0	23.0	Floor noise
Hori	700.000	QP	22.8	19.8	10.5	27.6	25.5	46.0	20.5	Floor noise
Hori	4882.000	PK	42.5	31.4	7.5	33.8	47.6	73.9	26.3	Floor noise
Hori	7323.000	PK	42.1	35.8	8.5	33.9	52.5	73.9	21.4	Floor noise
Hori	9764.000	PK	41.8	38.2	9.2	34.5	54.7	73.9	19.2	Floor noise
Hori	4882.000	AV	30.0	31.4	7.5	33.8	35.1	53.9	18.8	Floor noise
Hori	7323.000	AV	29.4	35.8	8.5	33.9	39.8	53.9	14.1	Floor noise
Hori	9764.000	AV	29.8	38.2	9.2	34.5	42.7	53.9	11.2	Floor noise
Vert	40.000	QP	24.6	14.1	6.8	28.2	17.3	40.0	22.7	Floor noise
Vert	100.000	QP	24.7	10.1	7.4	28.0	14.2	43.5	29.3	Floor noise
Vert	150.000	QP	23.9	14.8	7.8	27.8	18.7	43.5	24.8	Floor noise
Vert	300.000	QP	23.1	13.4	8.8	27.2	18.1	46.0	27.9	Floor noise
Vert	500.000	QP	23.7	17.7	9.8	28.1	23.1	46.0	22.9	Floor noise
Vert	700.000	QP	22.9	19.8	10.5	27.6	25.6	46.0	20.4	Floor noise
Vert	4882.000	PK	42.5	31.4	7.5	33.8	47.6	73.9	26.3	Floor noise
Vert	7323.000	PK	42.1	35.8	8.5	33.9	52.5	73.9	21.4	Floor noise
Vert	9764.000	PK	41.8	38.2	9.2	34.5	54.7	73.9	19.2	Floor noise
Vert	4882.000	AV	30.0	31.4	7.5	33.8	35.1	53.9	18.8	Floor noise
Vert	7323.000	AV	29.4	35.8	8.5	33.9	39.8	53.9	14.1	Floor noise
Vert	9764.000	AV	29.8	38.2	9.2	34.5	42.7	53.9	11.2	Floor noise

Result = Reading + Ant Factor + Loss (Cable+Attenuator+Filter+Distance factor(above 1 GHz)) - Gain(Amplifier)

*Other frequency noises omitted in this report were not seen or had enough margin (more than 20 dB).

Distance factor: 1 GHz - 10 GHz 20log(3.75 m / 3.0 m) = 1.94 dB
10 GHz - 26.5 GHz 20log(1.0 m / 3.0 m) = -9.5 dB

***These results have sufficient margin without taking account Dwell time factor.**

Radiated Spurious Emission

Report No. 11774441H
Test place Ise EMC Lab.
Semi Anechoic Chamber No.2 No.2 No.2
Date July 12, 2017 July 14, 2017 July 15, 2017
Temperature / Humidity 22 deg. C / 66 % RH 21 deg. C / 57 % RH 23 deg. C / 65 % RH
Engineer Tomoki Matsui Masafumi Niwa Takumi Shimada
(1 GHz -10 GHz) (10 GHz -26.5 GHz) (30 MHz -1000 MHz)
Mode Tx, Hopping Off, DH5 2480 MHz

Polarity	Frequency [MHz]	Detector	Reading [dBuV]	Ant.Fac. [dB/m]	Loss [dB]	Gain [dB]	Result [dBuV/m]	Limit [dBuV/m]	Margin [dB]	Remark
Hori	40.000	QP	24.6	14.1	6.8	28.2	17.3	40.0	22.7	Floor noise
Hori	100.000	QP	25.8	10.1	7.4	28.0	15.3	43.5	28.2	Floor noise
Hori	150.000	QP	24.0	14.8	7.8	27.8	18.8	43.5	24.7	Floor noise
Hori	300.000	QP	23.1	13.4	8.8	27.2	18.1	46.0	27.9	Floor noise
Hori	500.000	QP	23.6	17.7	9.8	28.1	23.0	46.0	23.0	Floor noise
Hori	700.000	QP	22.8	19.8	10.5	27.6	25.5	46.0	20.5	Floor noise
Hori	2483.500	PK	48.6	27.0	5.1	34.6	46.1	73.9	27.8	Floor noise
Hori	4960.000	PK	42.6	31.6	7.6	33.8	48.0	73.9	25.9	Floor noise
Hori	7440.000	PK	42.4	35.9	8.5	34.0	52.8	73.9	21.1	Floor noise
Hori	9920.000	PK	42.8	38.2	9.3	34.6	55.7	73.9	18.2	Floor noise
Hori	2483.500	AV	34.3	27.0	5.1	34.6	31.8	53.9	22.1	Floor noise
Hori	4960.000	AV	30.9	31.6	7.6	33.8	36.3	53.9	17.6	Floor noise
Hori	7440.000	AV	30.7	35.9	8.5	34.0	41.1	53.9	12.8	Floor noise
Hori	9920.000	AV	31.1	38.2	9.3	34.6	44.0	53.9	9.9	Floor noise
Vert	40.000	QP	24.6	14.1	6.8	28.2	17.3	40.0	22.7	Floor noise
Vert	100.000	QP	24.7	10.1	7.4	28.0	14.2	43.5	29.3	Floor noise
Vert	150.000	QP	23.9	14.8	7.8	27.8	18.7	43.5	24.8	Floor noise
Vert	300.000	QP	23.1	13.4	8.8	27.2	18.1	46.0	27.9	Floor noise
Vert	500.000	QP	23.7	17.7	9.8	28.1	23.1	46.0	22.9	Floor noise
Vert	700.000	QP	22.9	19.8	10.5	27.6	25.6	46.0	20.4	Floor noise
Vert	2483.500	PK	46.5	27.0	5.1	34.6	44.0	73.9	29.9	Floor noise
Vert	4960.000	PK	42.6	31.6	7.6	33.8	48.0	73.9	25.9	Floor noise
Vert	7440.000	PK	42.4	35.9	8.5	34.0	52.8	73.9	21.1	Floor noise
Vert	9920.000	PK	42.8	38.2	9.3	34.6	55.7	73.9	18.2	Floor noise
Vert	2483.500	AV	32.8	27.0	5.1	34.6	30.3	53.9	23.6	Floor noise
Vert	4960.000	AV	30.9	31.6	7.6	33.8	36.3	53.9	17.6	Floor noise
Vert	7440.000	AV	30.7	35.9	8.5	34.0	41.1	53.9	12.8	Floor noise
Vert	9920.000	AV	31.1	38.2	9.3	34.6	44.0	53.9	9.9	Floor noise

Result = Reading + Ant Factor + Loss (Cable+Attenuator+Filter+Distance factor(above 1 GHz)) - Gain(Amplifier)

*Other frequency noises omitted in this report were not seen or had enough margin (more than 20 dB).

Distance factor: 1 GHz - 10 GHz 20log (3.75 m / 3.0 m) = 1.94 dB
10 GHz - 26.5 GHz 20log (1.0 m / 3.0 m) = -9.5 dB

***These results have sufficient margin without taking account Dwell time factor.**

Radiated Spurious Emission
(Reference Plot for band-edge)

Report No. 11774441H
Test place Ise EMC Lab.
Semi Anechoic Chamber No.2
Date July 12, 2017
Temperature / Humidity 22 deg. C / 66 % RH
Engineer Tomoki Matsui
(1 GHz -10 GHz)
Mode Tx, Hopping Off, DH5 2480 MHz

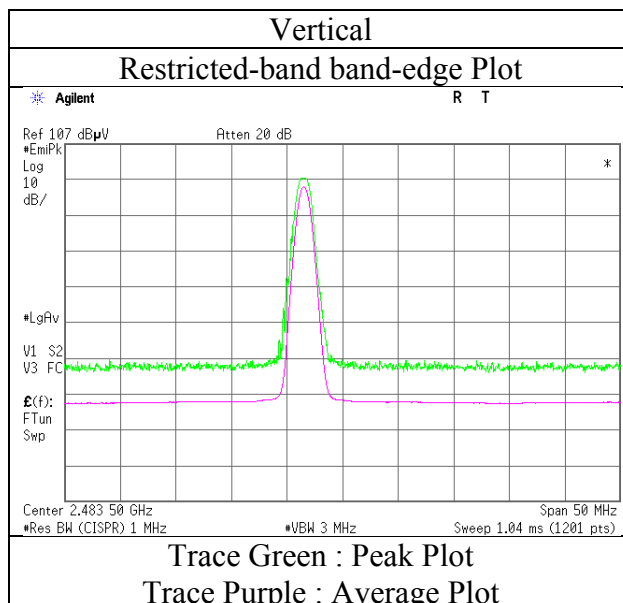
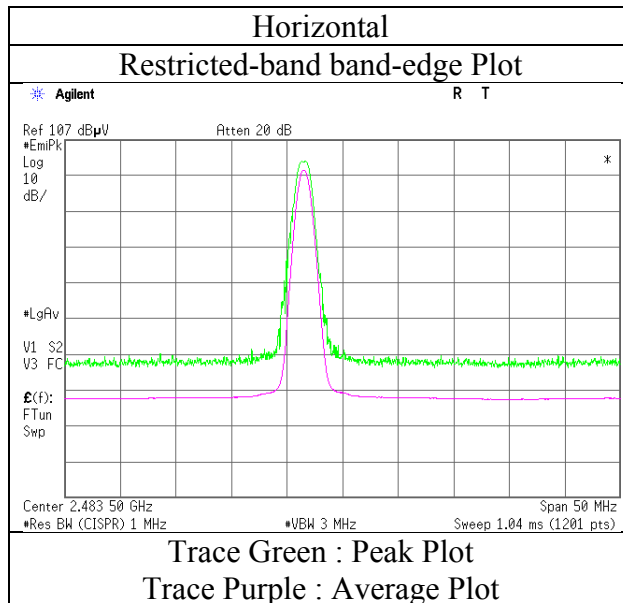

* Final result of restricted band edge was shown in tabular data.

Radiated Spurious Emission

Report No. 11774441H
Test place Ise EMC Lab.
Semi Anechoic Chamber No.2 No.2 No.2
Date July 12, 2017 July 14, 2017 July 15, 2017
Temperature / Humidity 22 deg. C / 66 % RH 21 deg. C / 57 % RH 23 deg. C / 65 % RH
Engineer Tomoki Matsui Masafumi Niwa Takumi Shimada
(1 GHz -10 GHz) (10 GHz -26.5 GHz) (30 MHz -1000 MHz)
Mode Tx, Hopping Off, 3DH5 2402 MHz

Polarity	Frequency [MHz]	Detector	Reading [dBuV]	Ant.Fac. [dB/m]	Loss [dB]	Gain [dB]	Result [dBuV/m]	Limit [dBuV/m]	Margin [dB]	Remark
Hori	40.000	QP	24.6	14.1	6.8	28.2	17.3	40.0	22.7	Floor noise
Hori	100.000	QP	25.9	10.1	7.4	28.0	15.4	43.5	28.1	Floor noise
Hori	150.000	QP	23.8	14.8	7.8	27.8	18.6	43.5	24.9	Floor noise
Hori	300.000	QP	23.0	13.4	8.8	27.2	18.0	46.0	28.0	Floor noise
Hori	500.000	QP	23.7	17.7	9.8	28.1	23.1	46.0	22.9	Floor noise
Hori	700.000	QP	22.9	19.8	10.5	27.6	25.6	46.0	20.4	Floor noise
Hori	2390.000	PK	43.4	27.0	4.9	34.6	40.7	73.9	33.2	
Hori	4804.000	PK	42.6	31.3	7.6	33.8	47.7	73.9	26.2	Floor noise
Hori	7206.000	PK	41.6	35.6	8.4	33.9	51.7	73.9	22.2	Floor noise
Hori	9608.000	PK	43.4	38.2	9.3	34.5	56.4	73.9	17.5	Floor noise
Hori	2390.000	AV	31.5	27.0	4.9	34.6	28.8	53.9	25.1	
Hori	4804.000	AV	29.8	31.3	7.6	33.8	34.9	53.9	19.0	Floor noise
Hori	7206.000	AV	29.8	35.6	8.4	33.9	39.9	53.9	14.0	Floor noise
Hori	9608.000	AV	30.0	38.2	9.3	34.5	43.0	53.9	10.9	Floor noise
Vert	40.000	QP	24.5	14.1	6.8	28.2	17.2	40.0	22.8	Floor noise
Vert	100.000	QP	24.8	10.1	7.4	28.0	14.3	43.5	29.2	Floor noise
Vert	150.000	QP	23.9	14.8	7.8	27.8	18.7	43.5	24.8	Floor noise
Vert	300.000	QP	23.1	13.4	8.8	27.2	18.1	46.0	27.9	Floor noise
Vert	500.000	QP	23.7	17.7	9.8	28.1	23.1	46.0	22.9	Floor noise
Vert	700.000	QP	22.9	19.8	10.5	27.6	25.6	46.0	20.4	Floor noise
Vert	2390.000	PK	44.1	27.0	4.9	34.6	41.4	73.9	32.5	
Vert	4804.000	PK	42.6	31.3	7.6	33.8	47.7	73.9	26.2	Floor noise
Vert	7206.000	PK	41.6	35.6	8.4	33.9	51.7	73.9	22.2	Floor noise
Vert	9608.000	PK	43.4	38.2	9.3	34.5	56.4	73.9	17.5	Floor noise
Vert	2390.000	AV	31.5	27.0	4.9	34.6	28.8	53.9	25.1	
Vert	4804.000	AV	29.8	31.3	7.6	33.8	34.9	53.9	19.0	Floor noise
Vert	7206.000	AV	29.8	35.6	8.4	33.9	39.9	53.9	14.0	Floor noise
Vert	9608.000	AV	30.0	38.2	9.3	34.5	43.0	53.9	10.9	Floor noise

Result = Reading + Ant Factor + Loss (Cable+Attenuator+Filter+Distance factor(above 1 GHz)) - Gain(Amplifier)
*Other frequency noises omitted in this report were not seen or had enough margin (more than 20 dB).

Distance factor: 1 GHz - 10 GHz 20log (3.75 m / 3.0 m) = 1.94 dB
10 GHz - 26.5 GHz 20log (1.0 m / 3.0 m) = -9.5 dB

20dBc Data Sheet

Polarity	Frequency [MHz]	Detector	Reading [dBuV]	Ant Factor [dB/m]	Loss [dB]	Gain [dB]	Result [dBuV/m]	Limit [dBuV/m]	Margin [dB]	Remark
Hori	2402.000	PK	98.0	27.0	5.0	34.6	95.4	-	-	Carrier
Hori	2400.000	PK	39.8	27.0	5.0	34.6	37.2	75.4	38.2	
Vert	2402.000	PK	94.8	27.0	5.0	34.6	92.2	-	-	Carrier
Vert	2400.000	PK	38.9	27.0	5.0	34.6	36.3	72.2	35.9	

Result = Reading + Ant Factor + Loss (Cable+Attenuator+Filter+Distance factor(above 1 GHz)) - Gain(Amplifier)

***These results have sufficient margin without taking account Dwell time factor.**

UL Japan, Inc.

Ise EMC Lab.

4383-326 Asama-cho, Ise-shi, Mie-ken 516-0021 JAPAN

Telephone : +81 596 24 8999

Facsimile : +81 596 24 8124

Radiated Spurious Emission
(Reference Plot for band-edge)

Report No.	11774441H
Test place	Ise EMC Lab.
Semi Anechoic Chamber	No.2
Date	July 12, 2017
Temperature / Humidity	22 deg. C / 66 % RH
Engineer	Tomoki Matsui
	(1 GHz -10 GHz)
Mode	Tx, Hopping Off, 3DH5 2402 MHz

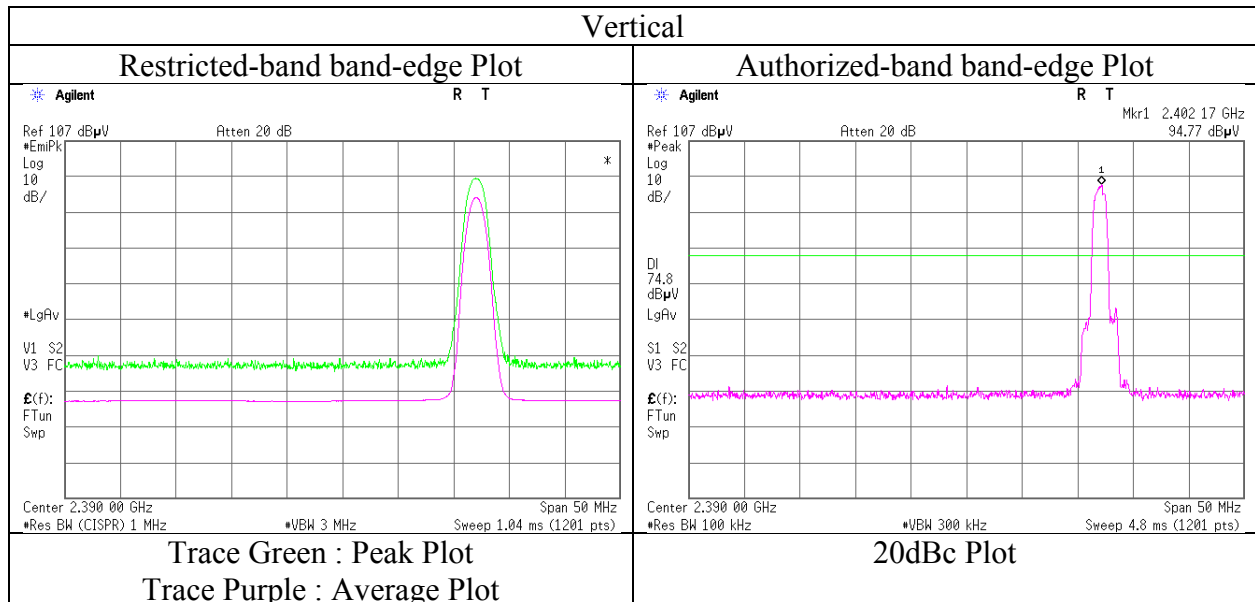
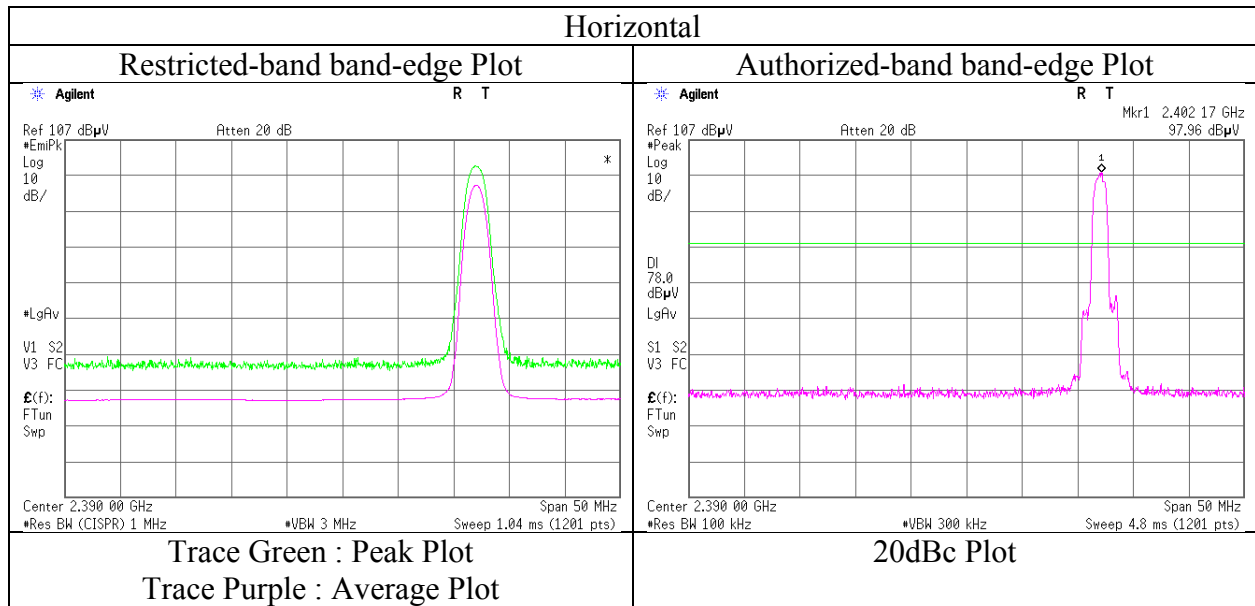

* Final result of restricted band edge was shown in tabular data.

UL Japan, Inc.

Ise EMC Lab.

4383-326 Asama-cho, Ise-shi, Mie-ken 516-0021 JAPAN

Telephone : +81 596 24 8999

Facsimile : +81 596 24 8124

Radiated Spurious Emission

Report No. 11774441H
Test place Ise EMC Lab.
Semi Anechoic Chamber No.2 No.2 No.2
Date July 12, 2017 July 14, 2017 July 15, 2017
Temperature / Humidity 22 deg. C / 66 % RH 21 deg. C / 57 % RH 23 deg. C / 65 % RH
Engineer Tomoki Matsui Masafumi Niwa Takumi Shimada
(1 GHz -10 GHz) (10 GHz -26.5 GHz) (30 MHz -1000 MHz)
Mode Tx, Hopping Off, 3DH5 2441 MHz

Polarity	Frequency [MHz]	Detector	Reading [dBuV]	Ant.Fac. [dB/m]	Loss [dB]	Gain [dB]	Result [dBuV/m]	Limit [dBuV/m]	Margin [dB]	Remark
Hori	40.000	QP	24.6	14.1	6.8	28.2	17.3	40.0	22.7	Floor noise
Hori	100.000	QP	25.7	10.1	7.4	28.0	15.2	43.5	28.3	Floor noise
Hori	150.000	QP	23.8	14.8	7.8	27.8	18.6	43.5	24.9	Floor noise
Hori	300.000	QP	23.1	13.4	8.8	27.2	18.1	46.0	27.9	Floor noise
Hori	500.000	QP	23.7	17.7	9.8	28.1	23.1	46.0	22.9	Floor noise
Hori	700.000	QP	22.8	19.8	10.5	27.6	25.5	46.0	20.5	Floor noise
Hori	4882.000	PK	42.5	31.4	7.5	33.8	47.6	73.9	26.3	Floor noise
Hori	7323.000	PK	42.1	35.8	8.5	33.9	52.5	73.9	21.4	Floor noise
Hori	9764.000	PK	41.8	38.2	9.2	34.5	54.7	73.9	19.2	Floor noise
Hori	4882.000	AV	30.0	31.4	7.5	33.8	35.1	53.9	18.8	Floor noise
Hori	7323.000	AV	29.4	35.8	8.5	33.9	39.8	53.9	14.1	Floor noise
Hori	9764.000	AV	29.8	38.2	9.2	34.5	42.7	53.9	11.2	Floor noise
Vert	40.000	QP	24.6	14.1	6.8	28.2	17.3	40.0	22.7	Floor noise
Vert	100.000	QP	24.7	10.1	7.4	28.0	14.2	43.5	29.3	Floor noise
Vert	150.000	QP	23.9	14.8	7.8	27.8	18.7	43.5	24.8	Floor noise
Vert	300.000	QP	23.1	13.4	8.8	27.2	18.1	46.0	27.9	Floor noise
Vert	500.000	QP	23.8	17.7	9.8	28.1	23.2	46.0	22.8	Floor noise
Vert	700.000	QP	22.9	19.8	10.5	27.6	25.6	46.0	20.4	Floor noise
Vert	4882.000	PK	42.5	31.4	7.5	33.8	47.6	73.9	26.3	Floor noise
Vert	7323.000	PK	42.1	35.8	8.5	33.9	52.5	73.9	21.4	Floor noise
Vert	9764.000	PK	41.8	38.2	9.2	34.5	54.7	73.9	19.2	Floor noise
Vert	4882.000	AV	30.0	31.4	7.5	33.8	35.1	53.9	18.8	Floor noise
Vert	7323.000	AV	29.4	35.8	8.5	33.9	39.8	53.9	14.1	Floor noise
Vert	9764.000	AV	29.8	38.2	9.2	34.5	42.7	53.9	11.2	Floor noise

Result = Reading + Ant Factor + Loss (Cable+Attenuator+Filter+Distance factor(above 1 GHz)) - Gain(Amplifier)

*Other frequency noises omitted in this report were not seen or had enough margin (more than 20 dB).

Distance factor: 1 GHz - 10 GHz 20log(3.75 m / 3.0 m) = 1.94 dB
10 GHz - 26.5 GHz 20log(1.0 m / 3.0 m) = -9.5 dB

***These results have sufficient margin without taking account Dwell time factor.**

Radiated Spurious Emission

Report No. 11774441H
Test place Ise EMC Lab.
Semi Anechoic Chamber No.2 No.2 No.2
Date July 12, 2017 July 14, 2017 July 15, 2017
Temperature / Humidity 22 deg. C / 66 % RH 21 deg. C / 57 % RH 23 deg. C / 65 % RH
Engineer Tomoki Matsui Masafumi Niwa Takumi Shimada
(1 GHz -10 GHz) (10 GHz -26.5 GHz) (30 MHz -1000 MHz)
Mode Tx, Hopping Off, 3DH5 2480 MHz

Polarity	Frequency [MHz]	Detector	Reading [dBuV]	Ant.Fac. [dB/m]	Loss [dB]	Gain [dB]	Result [dBuV/m]	Limit [dBuV/m]	Margin [dB]	Remark
Hori	40.000	QP	24.6	14.1	6.8	28.2	17.3	40.0	22.7	Floor noise
Hori	100.000	QP	25.8	10.1	7.4	28.0	15.3	43.5	28.2	Floor noise
Hori	150.000	QP	23.9	14.8	7.8	27.8	18.7	43.5	24.8	Floor noise
Hori	300.000	QP	23.2	13.4	8.8	27.2	18.2	46.0	27.8	Floor noise
Hori	500.000	QP	23.7	17.7	9.8	28.1	23.1	46.0	22.9	Floor noise
Hori	700.000	QP	22.9	19.8	10.5	27.6	25.6	46.0	20.4	Floor noise
Hori	2483.500	PK	48.1	27.0	5.1	34.6	45.6	73.9	28.3	
Hori	4960.000	PK	42.6	31.6	7.6	33.8	48.0	73.9	25.9	Floor noise
Hori	7440.000	PK	42.4	35.9	8.5	34.0	52.8	73.9	21.1	Floor noise
Hori	9920.000	PK	42.8	38.2	9.3	34.6	55.7	73.9	18.2	Floor noise
Hori	2483.500	AV	33.0	27.0	5.1	34.6	30.5	53.9	23.4	
Hori	4960.000	AV	30.9	31.6	7.6	33.8	36.3	53.9	17.6	Floor noise
Hori	7440.000	AV	30.7	35.9	8.5	34.0	41.1	53.9	12.8	Floor noise
Hori	9920.000	AV	31.1	38.2	9.3	34.6	44.0	53.9	9.9	Floor noise
Vert	40.000	QP	24.6	14.1	6.8	28.2	17.3	40.0	22.7	Floor noise
Vert	100.000	QP	24.9	10.1	7.4	28.0	14.4	43.5	29.1	Floor noise
Vert	150.000	QP	23.9	14.8	7.8	27.8	18.7	43.5	24.8	Floor noise
Vert	300.000	QP	23.1	13.4	8.8	27.2	18.1	46.0	27.9	Floor noise
Vert	500.000	QP	23.8	17.7	9.8	28.1	23.2	46.0	22.8	Floor noise
Vert	700.000	QP	22.9	19.8	10.5	27.6	25.6	46.0	20.4	Floor noise
Vert	2483.500	PK	46.1	27.0	5.1	34.6	43.6	73.9	30.3	
Vert	4960.000	PK	42.6	31.6	7.6	33.8	48.0	73.9	25.9	Floor noise
Vert	7440.000	PK	42.4	35.9	8.5	34.0	52.8	73.9	21.1	Floor noise
Vert	9920.000	PK	42.8	38.2	9.3	34.6	55.7	73.9	18.2	Floor noise
Vert	2483.500	AV	32.2	27.0	5.1	34.6	29.7	53.9	24.2	
Vert	4960.000	AV	30.9	31.6	7.6	33.8	36.3	53.9	17.6	Floor noise
Vert	7440.000	AV	30.7	35.9	8.5	34.0	41.1	53.9	12.8	Floor noise
Vert	9920.000	AV	31.1	38.2	9.3	34.6	44.0	53.9	9.9	Floor noise

Result = Reading + Ant Factor + Loss (Cable+Attenuator+Filter+Distance factor(above 1 GHz)) - Gain(Amplifier)

*Other frequency noises omitted in this report were not seen or had enough margin (more than 20 dB).

Distance factor: 1 GHz - 10 GHz 20log(3.75 m / 3.0 m) = 1.94 dB
10 GHz - 26.5 GHz 20log(1.0 m / 3.0 m) = -9.5 dB

***These results have sufficient margin without taking account Dwell time factor.**

Radiated Spurious Emission
(Reference Plot for band-edge)

Report No. 11774441H
Test place Ise EMC Lab.
Semi Anechoic Chamber No.2
Date July 12, 2017
Temperature / Humidity 22 deg. C / 66 % RH
Engineer Tomoki Matsui
(1 GHz -10 GHz)
Mode Tx, Hopping Off, 3DH5 2480 MHz

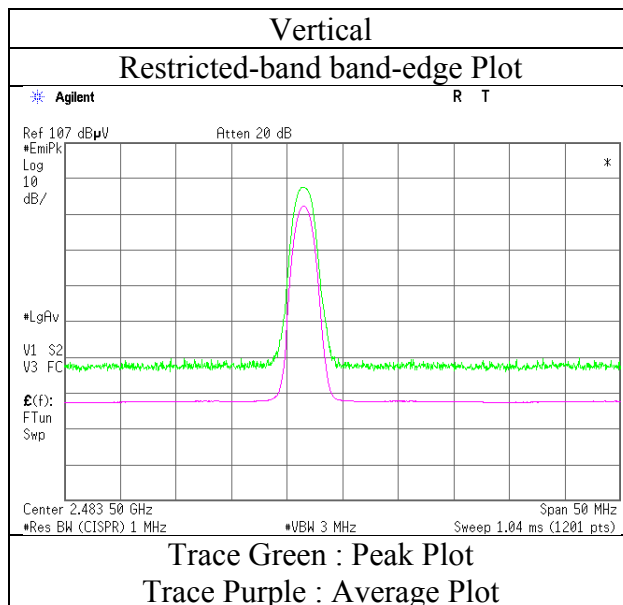
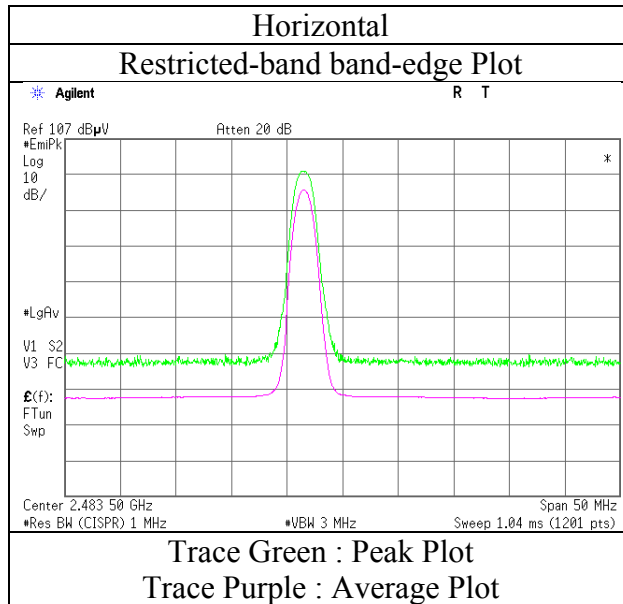

* Final result of restricted band edge was shown in tabular data.

Radiated Spurious Emission
(Plot data, Worst case)

Report No.	11774441H		
Test place	Ise EMC Lab.		
Semi Anechoic Chamber	No.2	No.2	No.2
Date	July 12, 2017	July 14, 2017	July 15, 2017
Temperature / Humidity	22 deg. C / 66 % RH	21 deg. C / 57 % RH	23 deg. C / 65 % RH
Engineer	Tomoki Matsui	Masafumi Niwa	Takumi Shimada
	(1 GHz -10 GHz)	(10 GHz -26.5 GHz)	(30 MHz -1000 MHz)
Mode	Tx, Hopping Off, DH5 2402 MHz		

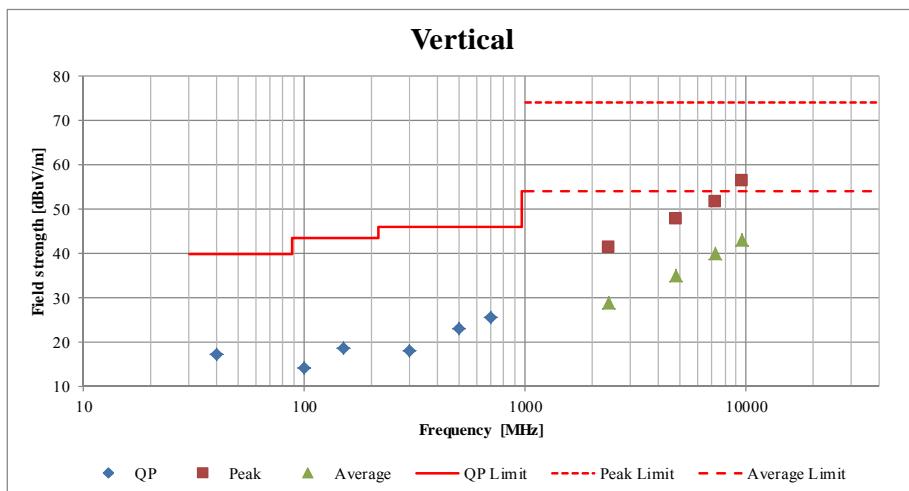
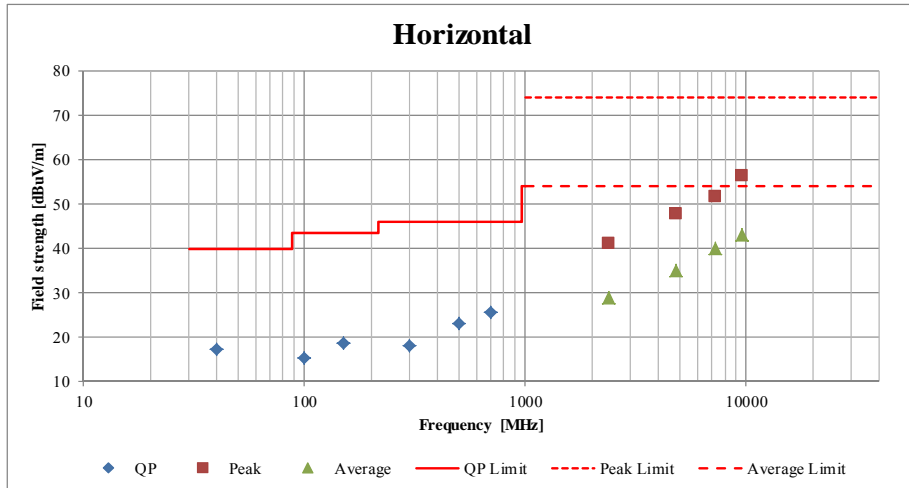

*These plots data contains sufficient number to show the trend of characteristic features for EUT.

Conducted Spurious Emission

Test place	Ise EMC Lab. No.6 Measurement Room
Report No.	11774441H
Date	July 14, 2017
Temperature / Humidity	25 deg. C / 58 % RH
Engineer	Takumi Shimada
Mode	Tx, Hopping Off, DH5

2402 MHz

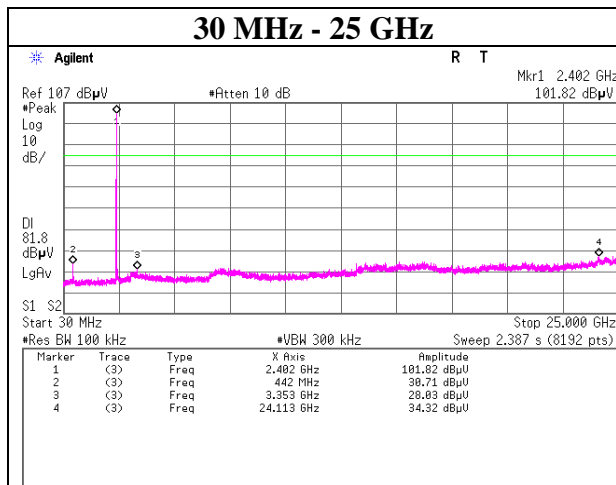
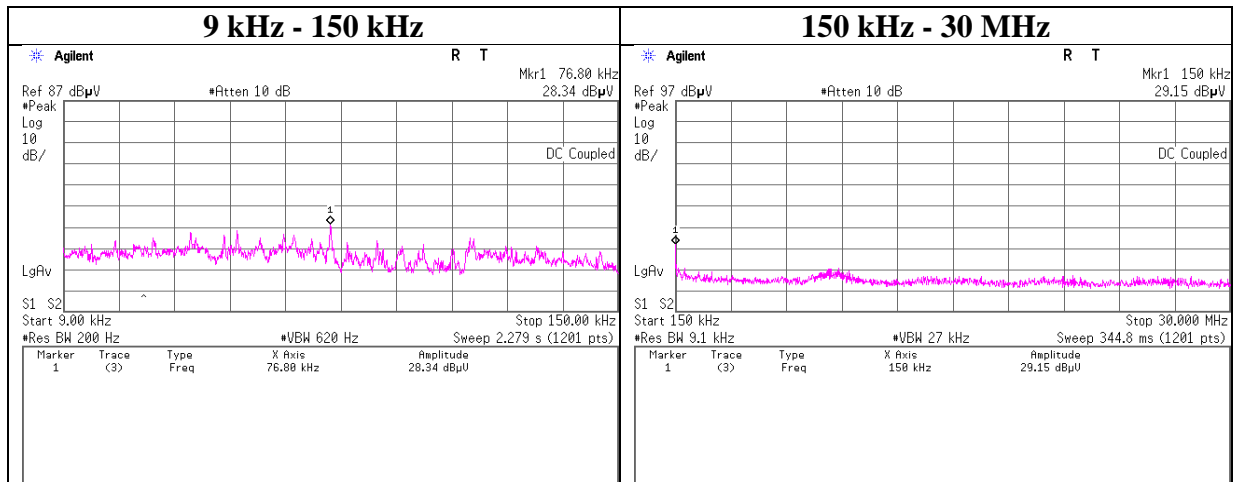

UL Japan, Inc.

Ise EMC Lab.

4383-326 Asama-cho, Ise-shi, Mie-ken 516-0021 JAPAN

Telephone : +81 596 24 8999

Facsimile : +81 596 24 8124

Conducted Spurious Emission

Test place	Ise EMC Lab. No.6 Measurement Room
Report No.	11774441H
Date	July 14, 2017
Temperature / Humidity	25 deg. C / 58 % RH
Engineer	Takumi Shimada
Mode	Tx, Hopping Off, DH5

2441 MHz

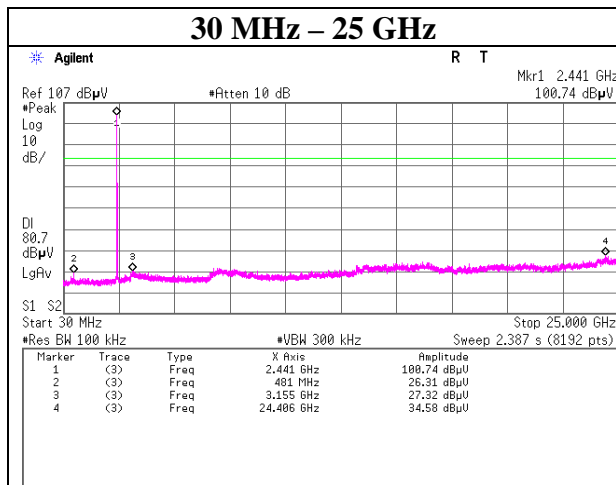
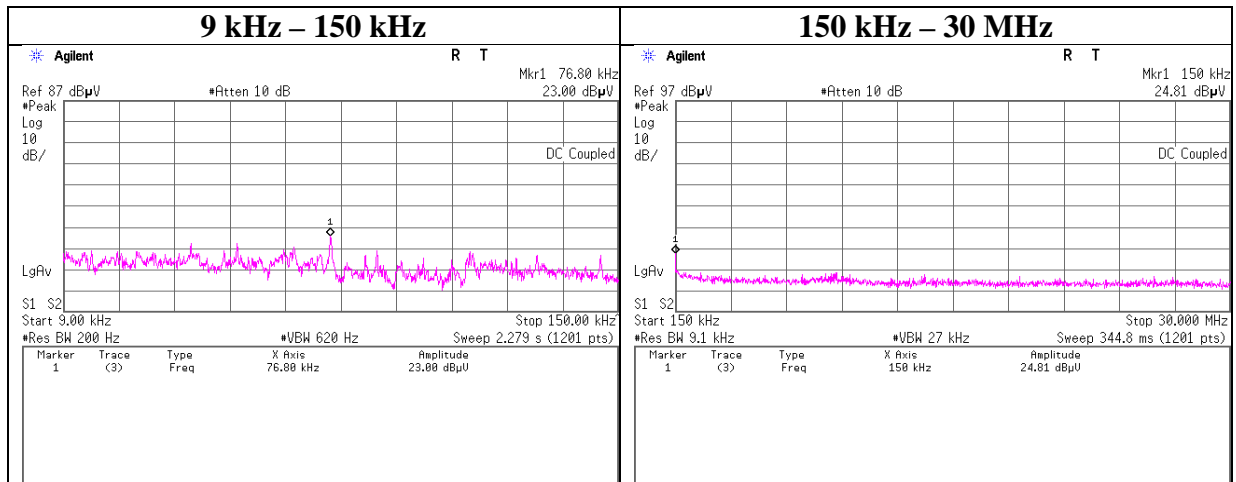

UL Japan, Inc.

Ise EMC Lab.

4383-326 Asama-cho, Ise-shi, Mie-ken 516-0021 JAPAN

Telephone : +81 596 24 8999

Facsimile : +81 596 24 8124

Conducted Spurious Emission

Test place	Ise EMC Lab. No.6 Measurement Room
Report No.	11774441H
Date	July 14, 2017
Temperature / Humidity	25 deg. C / 58 % RH
Engineer	Takumi Shimada
Mode	Tx, Hopping Off, DH5

2480 MHz

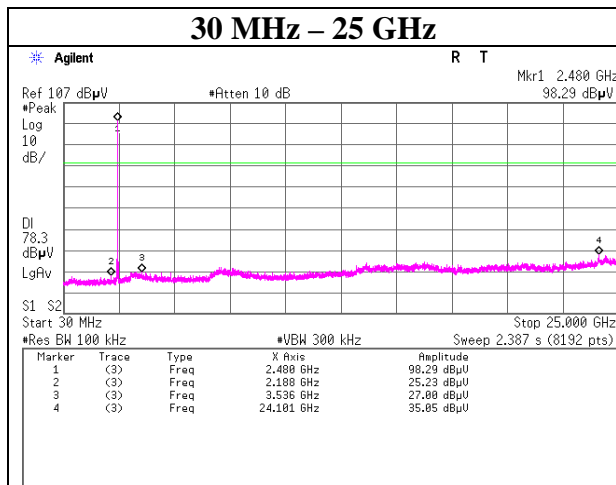
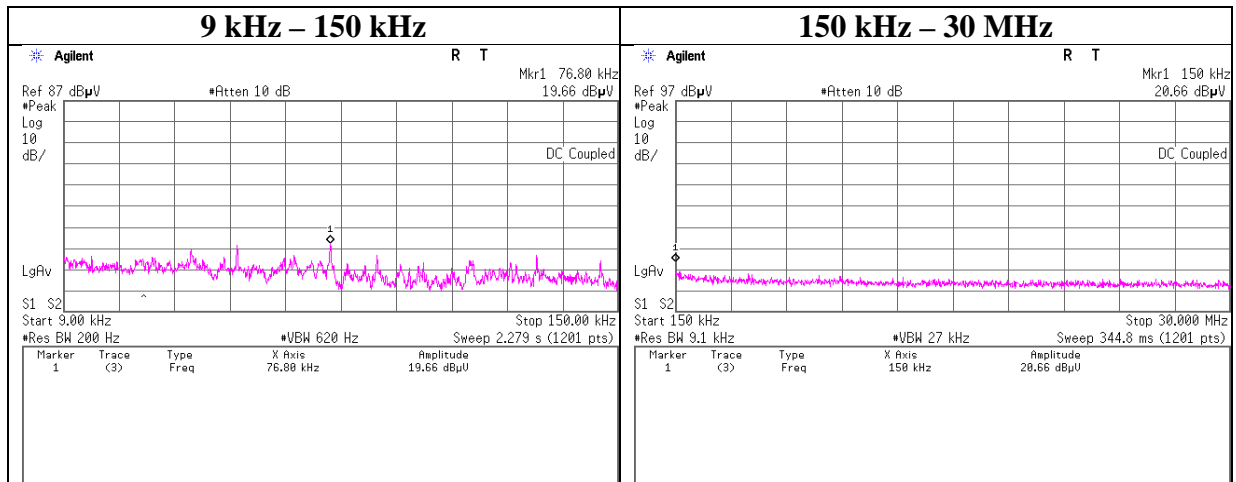

Conducted Spurious Emission

Test place	Ise EMC Lab. No.6 Measurement Room
Report No.	11774441H
Date	July 14, 2017
Temperature / Humidity	25 deg. C / 58 % RH
Engineer	Takumi Shimada
Mode	Tx, Hopping Off, 3DH5

2402 MHz

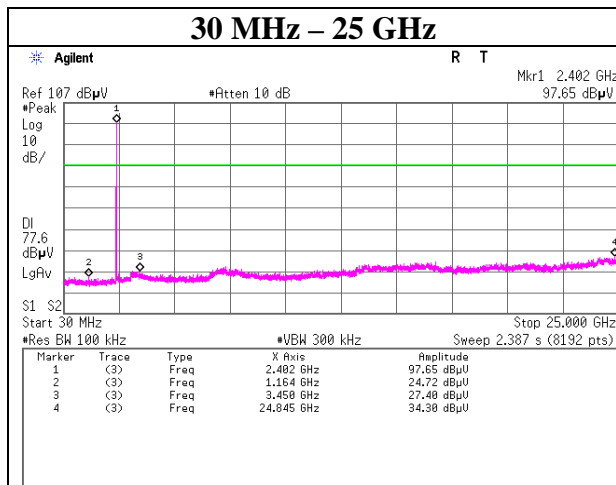
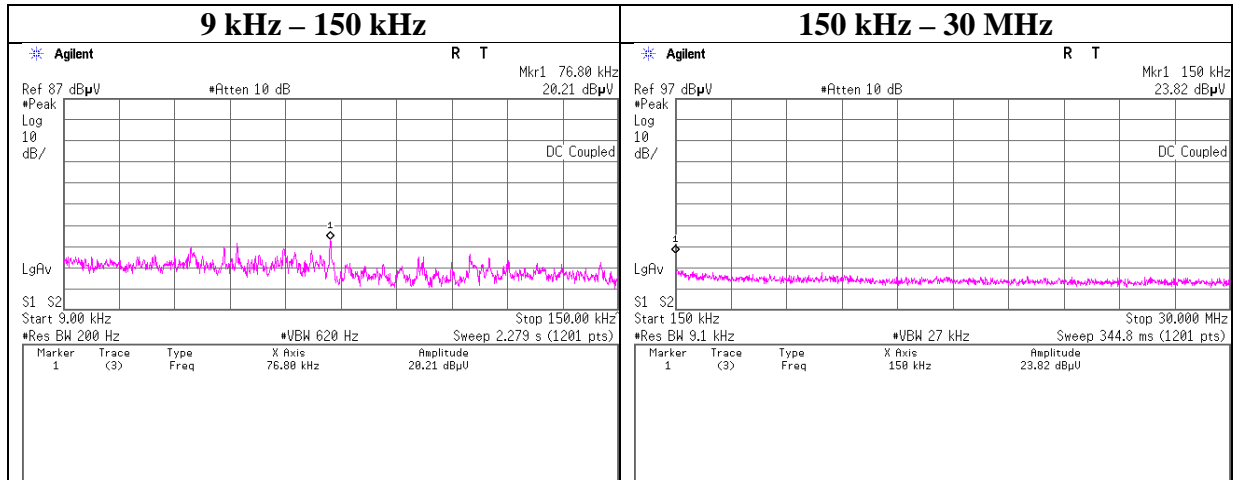

Conducted Spurious Emission

Test place	Ise EMC Lab. No.6 Measurement Room
Report No.	11774441H
Date	July 14, 2017
Temperature / Humidity	25 deg. C / 58 % RH
Engineer	Takumi Shimada
Mode	Tx, Hopping Off, 3DH5

2441 MHz

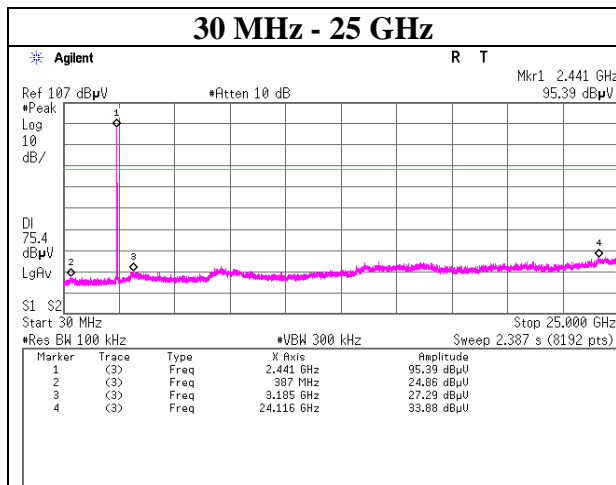
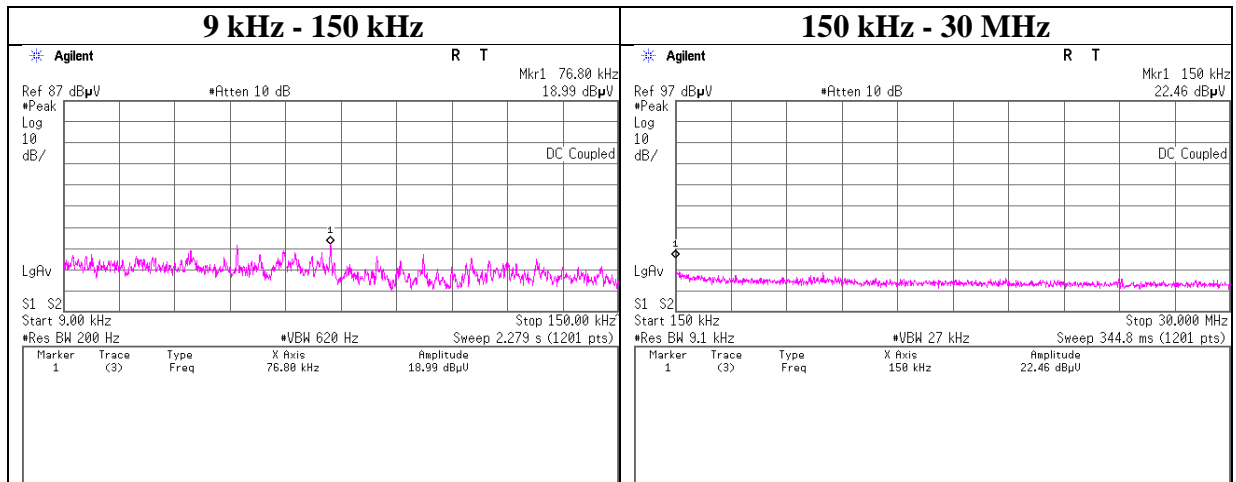

Conducted Spurious Emission

Test place	Ise EMC Lab. No.6 Measurement Room
Report No.	11774441H
Date	July 14, 2017
Temperature / Humidity	25 deg. C / 58 % RH
Engineer	Takumi Shimada
Mode	Tx, Hopping Off, 3DH5

2480 MHz

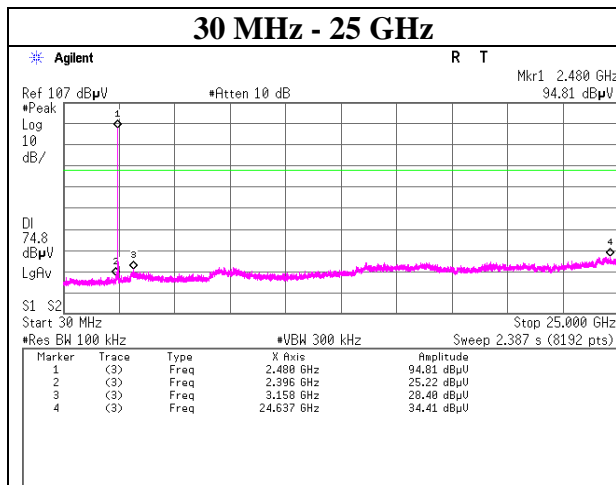
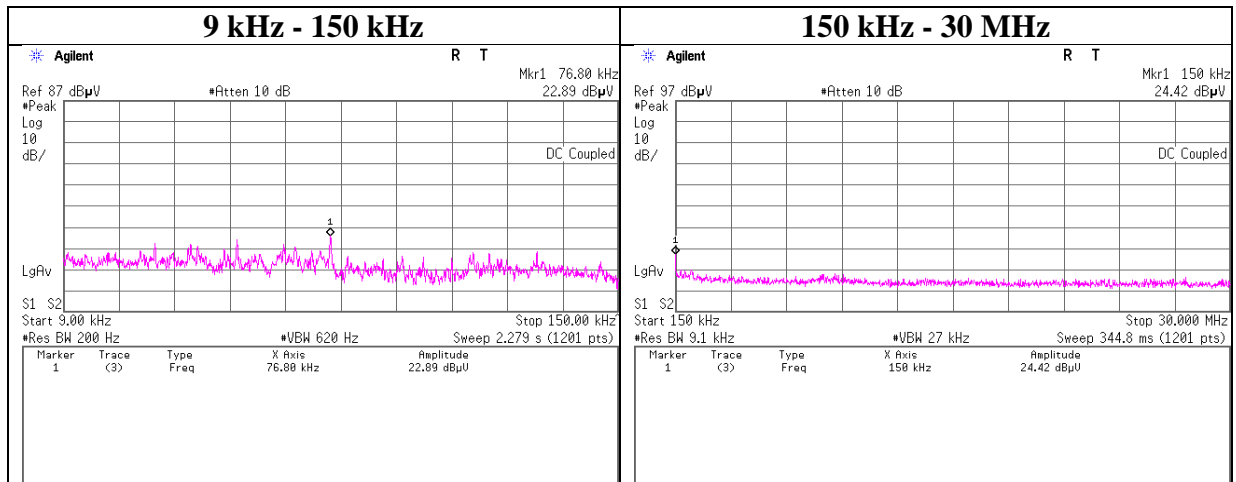

Conducted Emission Band Edge compliance

Test place	Ise EMC Lab. No.6 Measurement Room
Report No.	11774441H
Date	July 14, 2017
Temperature / Humidity	25 deg. C / 58 % RH
Engineer	Takumi Shimada
Mode	Tx DH5

Hopping On

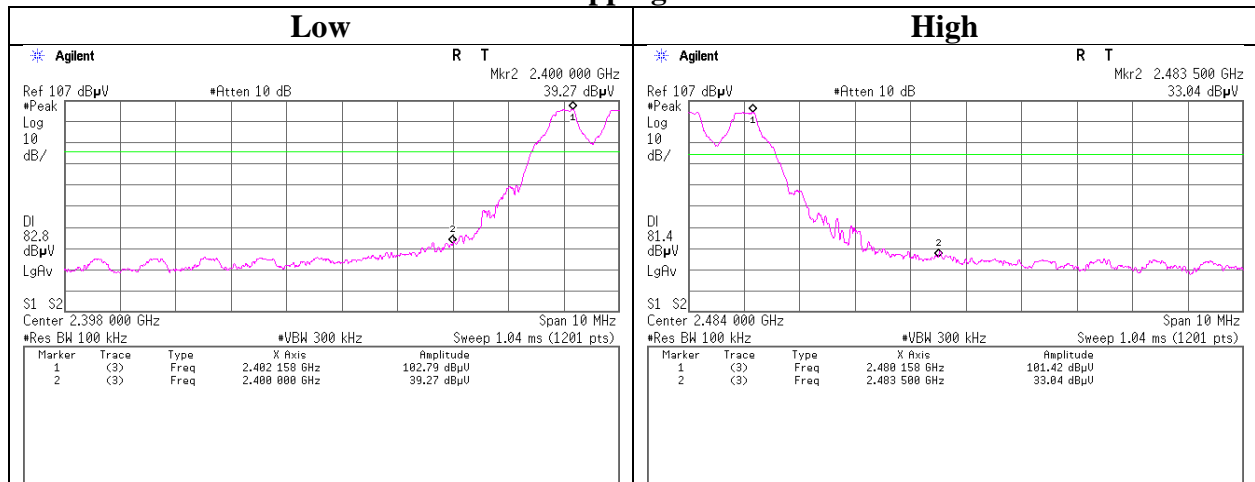

Hopping Off

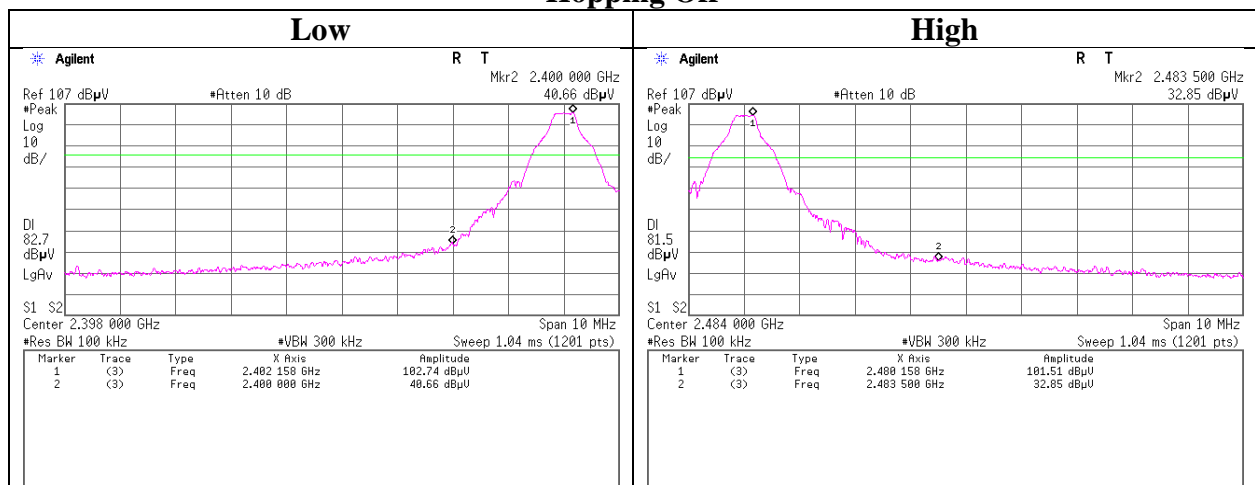

UL Japan, Inc.

Ise EMC Lab.

4383-326 Asama-cho, Ise-shi, Mie-ken 516-0021 JAPAN

Telephone : +81 596 24 8999

Facsimile : +81 596 24 8124

Conducted Emission Band Edge compliance

Test place	Ise EMC Lab. No.6 Measurement Room
Report No.	11774441H
Date	July 14, 2017
Temperature / Humidity	25 deg. C / 58 % RH
Engineer	Takumi Shimada
Mode	Tx 3DH5

Hopping On

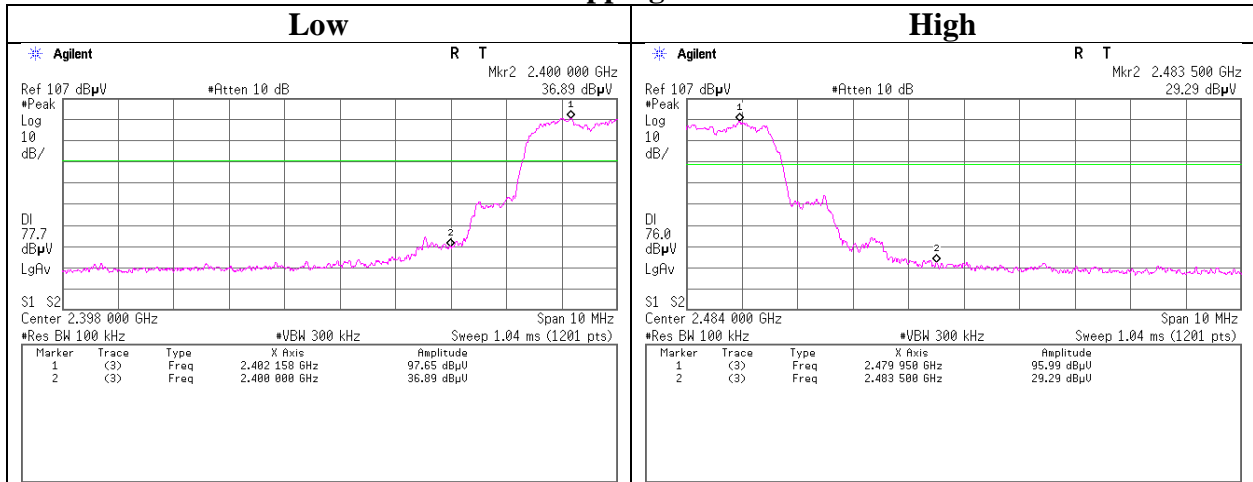

Hopping Off

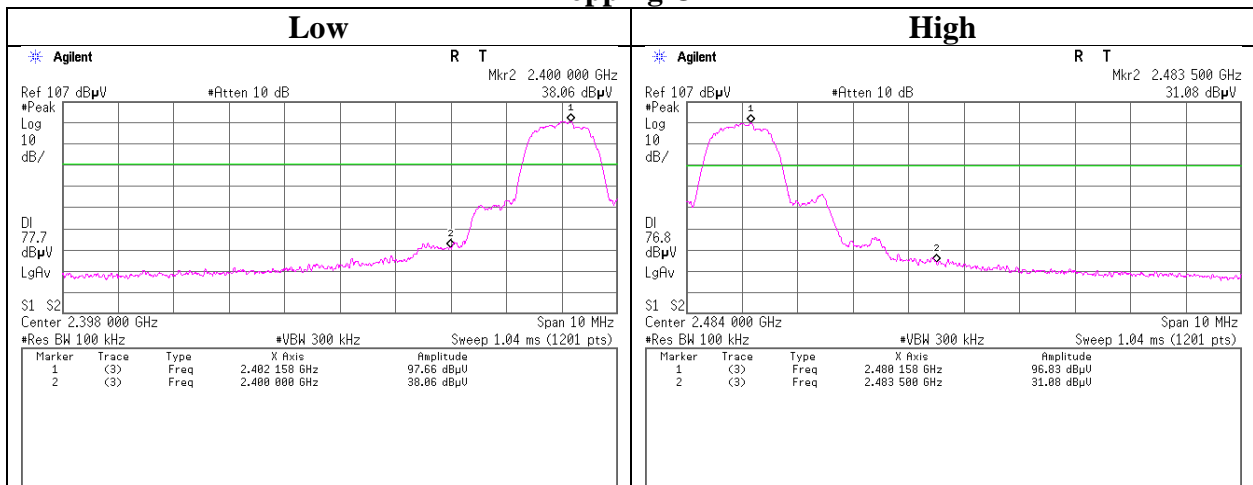

UL Japan, Inc.

Ise EMC Lab.

4383-326 Asama-cho, Ise-shi, Mie-ken 516-0021 JAPAN

Telephone : +81 596 24 8999

Facsimile : +81 596 24 8124

99% Occupied Bandwidth

Test place	Ise EMC Lab. No.6 Measurement Room
Report No.	11774441H
Date	July 14, 2017
Temperature / Humidity	25 deg. C / 58 % RH
Engineer	Takumi Shimada
Mode	Tx Hopping Off

Hopping Off, DH5

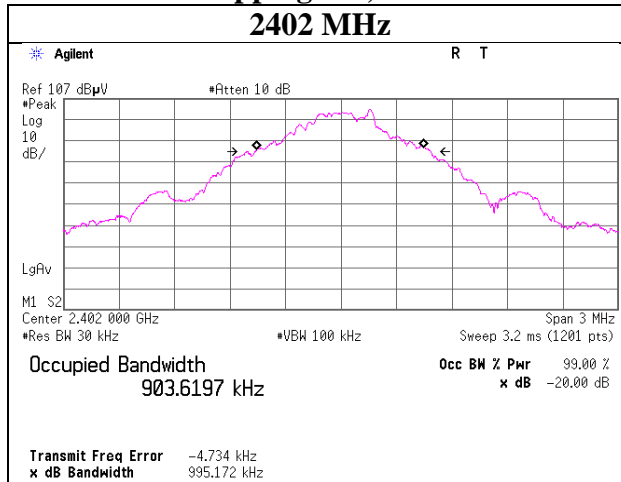

Hopping Off, 3DH5

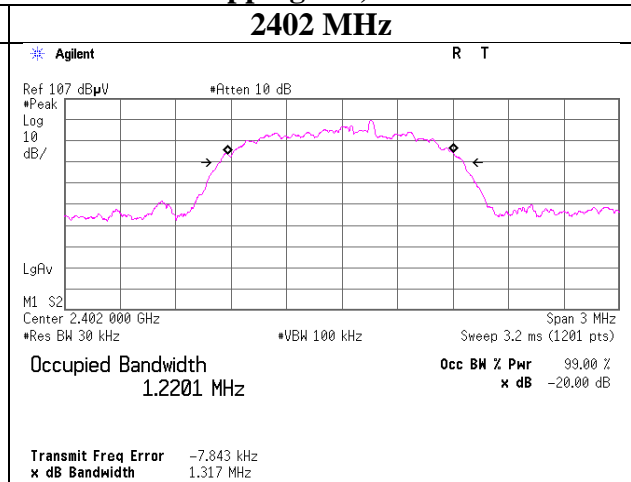

2441 MHz

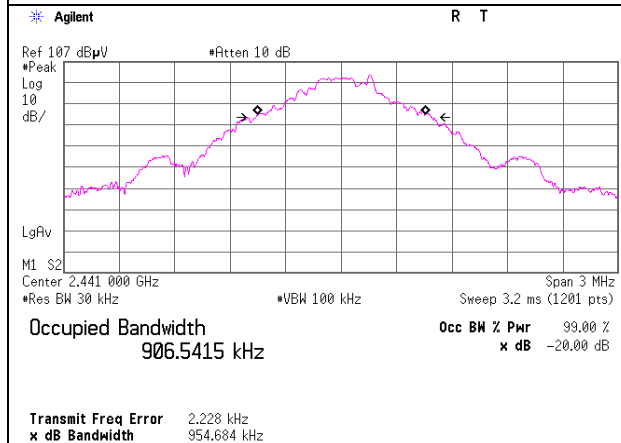

2441 MHz

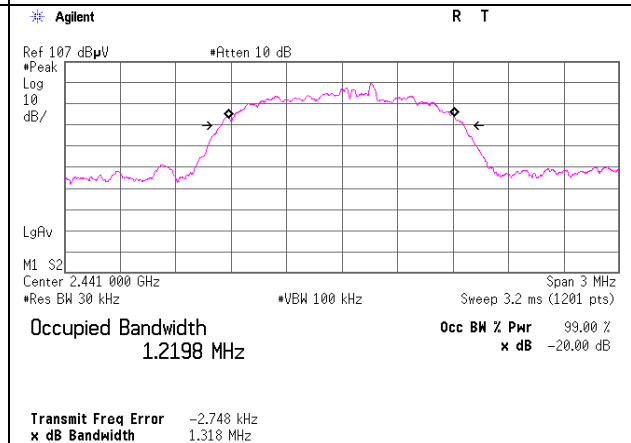

2480 MHz

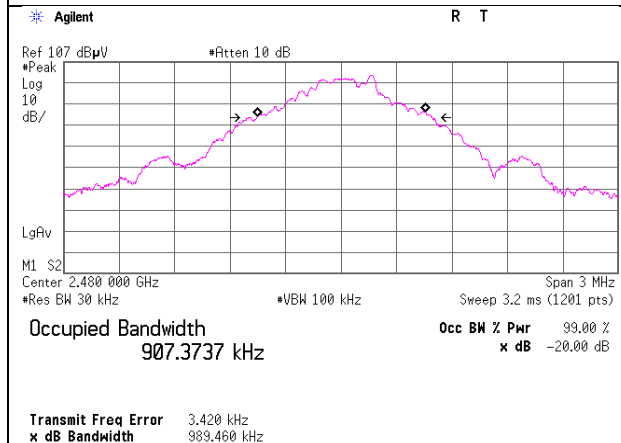

2480 MHz

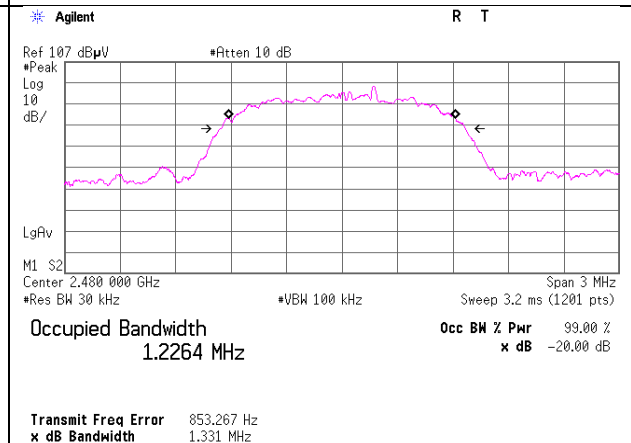

UL Japan, Inc.

Ise EMC Lab.

4383-326 Asama-cho, Ise-shi, Mie-ken 516-0021 JAPAN

Telephone : +81 596 24 8999

Facsimile : +81 596 24 8124

APPENDIX 2: Test instruments

Test equipment

Control No.	Instrument	Manufacturer	Model No	Serial No	Test Item	Calibration Date * Interval(month)
MPSE-11	Power sensor	Anritsu	MA2411B	011737	AT	2016/10/07 * 12
MAT-56	Attenuator(10dB)	Suhner	6810.19.A	-	AT	2016/12/14 * 12
MOS-19	Thermo-Hygrometer	Custom	CTH-201	0001	AT	2016/12/13 * 12
MCC-174	Microwave Cable	Junkosha	MWX221	1409S497	AT	2017/03/13 * 12
MAT-22	Attenuator(10dB) 1-18GHz	Orient Microwave	BX10-0476-00	-	AT	2017/03/21 * 12
MSA-15	Spectrum Analyzer	Agilent	E4440A	MY46187105	AT	2016/10/13 * 12
MPM-08	Power Meter	Anritsu	ML2495A	6K00003338	AT	2016/10/07 * 12
MMM-17	DIGITAL HiTESTER	Hioki	3805	070900530	AT	2017/01/19 * 12
MAEC-02	Semi Anechoic Chamber(NSA)	TDK	Semi Anechoic Chamber 3m	DA-06902	RE	2016/08/02 * 12
MOS-22	Thermo-Hygrometer	Custom	CTH-201	0003	RE	2016/12/13 * 12
MJM-14	Measure	KOMELON	KMC-36	-	RE	-
COTS-MEMI	EMI measurement program	TSJ	TEPTO-DV	-	RE./ CE	-
MSA-14	Spectrum Analyzer	Agilent	E4440A	MY48250080	RE	2016/10/14 * 12
MHA-06	Horn Antenna 1-18GHz	Schwarzbeck	BBHA9120D	254	RE	2017/02/24 * 12
MCC-216	Microwave Cable	Junkosha	MWX221	1604S253(1 m) / 1608S087(5 m)	RE	2016/08/29 * 12
MPA-10	Pre Amplifier	Agilent	8449B	3008A02142	RE	2017/01/16 * 12
MMM-01	Digital Tester	Fluke	FLUKE 26-3	78030611	RE	2016/08/23 * 12
MHF-26	High Pass Filter 3.5-18.0GHz	UL Japan	HPF SELECTOR	002	RE	2016/09/19 * 12
MHA-02	Horn Antenna 18-26.5GHz	EMCO	3160-09	1265	RE	2017/02/24 * 12
MHA-29	Horn Antenna 26.5-40GHz	ETS LINDGREN	3160-10	00152399	RE	2016/09/28 * 12
MPA-22	Pre Amplifier	MITEQ, Inc	AMF-6F-2600400-3 3-8P / AMF-4F-2600400-3 3-8P	1871355 /1871328	RE	2016/09/06 * 12
MCC-55	Microwave Cable	Suhner	SUCOFLEX101	2874(1m) / 2877(5m)	RE	2017/03/02 * 12
MSA-04	Spectrum Analyzer	Agilent	E4448A	US44300523	RE	2016/11/10 * 12
MBA-08	Biconical Antenna	Schwarzbeck	VHA9103B	08031	RE	2016/09/29 * 12
MLA-21	Logperiodic Antenna(200-1000MHz)	Schwarzbeck	VUSLP9111B	911B-190	RE	2017/01/05 * 12
MAT-07	Attenuator(6dB)	Weinschel Corp	2	BK7970	RE	2016/11/28 * 12
MCC-12	Coaxial Cable	Fujikura/Agilent	-	-	RE	2017/02/24 * 12
MPA-09	Pre Amplifier	Agilent	8447D	2944A10845	RE	2016/09/13 * 12
MTR-03	Test Receiver	Rohde & Schwarz	ESCI	100300	RE	2016/10/21 * 12
MSA-16	Spectrum Analyzer	Agilent	E4440A	MY46186390	AT	2017/02/21 * 12
MPM-16	Power Meter	Agilent	8990B	MY51000271	AT	2017/04/28 * 12
MPSE-22	Power sensor	Agilent	N1923A	MY54070003	AT	2017/04/28 * 12
MAT-10	Attenuator(10dB)	Weinschel Corp	2	BL1173	AT	2016/11/28 * 12
MAEC-03	Semi Anechoic Chamber(NSA)	TDK	Semi Anechoic Chamber 3m	DA-10005	CE	2016/10/20 * 12
MOS-13	Thermo-Hygrometer	Custom	CTH-180	1301	CE	2017/01/20 * 12
MJM-16	Measure	KOMELON	KMC-36	-	CE	-
MSA-03	Spectrum Analyzer	Agilent	E4448A	MY44020357	CE	2017/05/29 * 12
MTR-08	Test Receiver	Rohde & Schwarz	ESCI	100767	CE	2016/09/15 * 12
MLS-23	LISN(AMN)	Schwarzbeck	NSLK8127	8127-729	CE(EUT)	2016/07/07 * 12
MCC-112	Coaxial cable	Fujikura/Suhner/TSJ	5D-2W(10m)/SFM14 1(3m)/sucoform141- PE(1m)/421-010(1.5 m)/RFM-E321(Swite her)	-/00640	CE	2017/07/12 * 12
MAT-66	Attenuator(13dB)	JFW Industries, Inc.	50FP-013H2 N	-	CE	2016/12/24 * 12
MMM-08	DIGITAL HiTESTER	Hioki	3805	051201197	CE	2017/01/19 * 12

UL Japan, Inc.

Ise EMC Lab.

4383-326 Asama-cho, Ise-shi, Mie-ken 516-0021 JAPAN

Telephone : +81 596 24 8999

Facsimile : +81 596 24 8124

The expiration date of the calibration is the end of the expired month.

All equipment is calibrated with valid calibrations. Each measurement data is traceable to the national or international standards.

As for some calibrations performed after the tested dates, those test equipment have been controlled by means of an unbroken chains of calibrations.

**Test Item: CE: Conducted Emission test
RE: Radiated Emission test
AT: Antenna Terminal Conducted test**