



RADIO TEST REPORT

Test Report No. : 11219693H-A

Applicant : Murata Manufacturing Co., Ltd.
Type of Equipment : Communication Module
Model No. : Type1HD
FCC ID : VPYLB1HD
Test regulation : FCC Part 15 Subpart C: 2016
Test Result : Complied

1. This test report shall not be reproduced in full or partial, without the written approval of UL Japan, Inc.
2. The results in this report apply only to the sample tested.
3. This sample tested is in compliance with the above regulation.
4. The test results in this report are traceable to the national or international standards.
5. This test report must not be used by the customer to claim product certification, approval, or endorsement by NVLAP, NIST, or any agency of the Federal Government.
6. This test report covers Radio technical requirements. It does not cover administrative issues such as Manual or non-Radio test related Requirements. (if applicable)

Date of test: March 30 to May 12, 2016

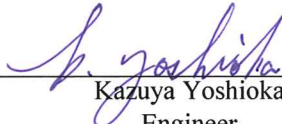
Representative test engineer: 
Kazuya Yoshioka
Engineer
Consumer Technology Division

Approved by: 
Takayuki Shimada
Engineer
Consumer Technology Division

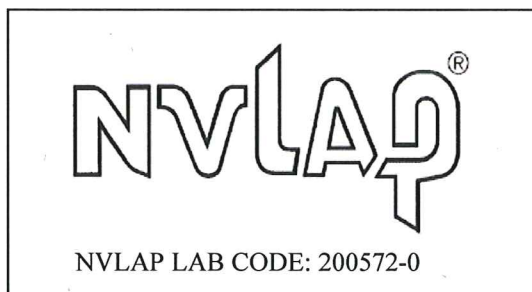

This laboratory is accredited by the NVLAP LAB CODE 200572-0, U.S.A. The tests reported herein have been performed in accordance with its terms of accreditation.
*As for the range of Accreditation in NVLAP, you may refer to the WEB address,
http://japan.ul.com/resources/emc_accredited/

CONTENTS	PAGE
SECTION 1: Customer information.....	4
SECTION 2: Equipment under test (E.U.T.).....	4
SECTION 3: Test specification, procedures & results.....	5
SECTION 4: Operation of E.U.T. during testing.....	8
SECTION 5: Conducted Emission.....	11
SECTION 6: Radiated Spurious Emission	12
SECTION 7: Antenna Terminal Conducted Tests.....	14
APPENDIX 1: Test data	15
Conducted Emission	15
6dB Bandwidth	16
Maximum Peak Output Power	19
Average Output Power	22
Radiated Spurious Emission	24
Conducted Spurious Emission	39
Power Density	40
99% Occupied Bandwidth	44
APPENDIX 2: Test instruments	46
APPENDIX 3: Photographs of test setup	48
Conducted Emission	48
Radiated Spurious Emission	49
Worst Case Position	50

SECTION 1: Customer information

Company Name : Murata Manufacturing Co., Ltd.
Address : 1-10-1 Higashikotari, Nagaokakyo-shi, Kyoto 617-8555 Japan
Telephone Number : +81-75-955-6736
Facsimile Number : +81-75-955-6634
Contact Person : Motoo Hayashi

SECTION 2: Equipment under test (E.U.T.)

2.1 Identification of E.U.T.

Type of Equipment : Communication Module
Model No. : Type1HD
Serial No. : Refer to Section 4, Clause 4.2
Rating : VDD_WLAN: Min3.2V, Typ3.3V, Max4.8V
 *VDD_IO_MCU: Min2.7V, Typ3.3V, Max3.6V
 *This doesn't influence the RF Characteristic.
Receipt Date of Sample : March 30, 2016
Country of Mass-production : China
Condition of EUT : Engineering prototype
 (Not for Sale: This sample is equivalent to mass-produced items.)
Modification of EUT : No Modification by the test lab

2.2 Product Description

Model: Type1HD (referred to as the EUT in this report) is a Communication Module.

General Specification

Clock frequency(ies) in the system : 32.768kHz, 37.4MHz, 26MHz
Operating temperature : -40 deg. C to +85 deg. C

Radio Specification

WLAN (IEEE802.11b/g/n-20)

Equipment Type	Transceiver
Frequency of Operation	2412 MHz - 2462 MHz
Type of Modulation	DSSS, OFDM
Bandwidth & Channel spacing	20 MHz & 5 MHz
Method of frequency generation	Synthesizer
Power Supply (inner)	3.3 V
Antenna Type	Monopole Antenna
Antenna Gain	-2.6 dBi

SECTION 3: Test specification, procedures & results

3.1 Test Specification

Test Specification : FCC Part 15 Subpart C
FCC part 15 final revised on April 6, 2016.

Title : FCC 47CFR Part15 Radio Frequency Device Subpart C Intentional Radiators
Section 15.207 Conducted limits
Section 15.247 Operation within the bands 902-928MHz,
2400-2483.5MHz, and 5725-5850MHz

3.2 Procedures and results

Item	Test Procedure	Specification	Worst margin	Results	Remarks
Conducted Emission	FCC: ANSI C63.10-2013 6. Standard test methods IC: RSS-Gen 8.8	FCC: Section 15.207 IC: RSS-Gen 8.8	QP 29.6 dB, 7.15822 MHz, L AV 25.3 dB, 7.15822 MHz, L	Complied	-
6dB Bandwidth	FCC: KDB 558074 D01 DTS Meas Guidance v03r05 IC: -	FCC: Section 15.247(a)(2) IC: RSS-247 5.2(1)	See data.	Complied	Conducted
Maximum Peak Output Power	FCC: KDB 558074 D01 DTS Meas Guidance v03r05 IC: RSS-Gen 6.12	FCC: Section 15.247(b)(3) IC: RSS-247 5.4(4)		Complied	Conducted
Power Density	FCC: KDB 558074 D01 DTS Meas Guidance v03r05 IC: -	FCC: Section 15.247(e) IC: RSS-247 5.2(2)		Complied	Conducted
Spurious Emission Restricted Band Edges	FCC: KDB 558074 D01 DTS Meas Guidance v03r04 IC: RSS-Gen 6.13	FCC: Section 15.247(d) IC: RSS-247 5.5 RSS-Gen 8.9 RSS-Gen 8.10	1.8 dB 2390.000 MHz, AV, Vertical	Complied	Conducted (below 30 MHz)/ Radiated (above 30 MHz) *1)

Note: UL Japan, Inc.'s EMI Work Procedures No. 13-EM-W0420 and 13-EM-W0422.

*1) Radiated test was selected over 30 MHz based on section 15.247(d) and KDB 558074 D01 DTS Meas Guidance v03r05 12.2.7.

* In case any questions arise about test procedure, ANSI C63.10: 2013 is also referred.

FCC Part 15.31 (e)

The RF Module has its own regulator.

The RF Module is constantly provided voltage (3.3V) through the regulator regardless of input voltage. Therefore, this EUT complies with the requirement.

FCC Part 15.203/212 Antenna requirement

It is impossible for end users to replace the antenna, because the antenna is mounted inside of the EUT. Therefore, the equipment complies with the antenna requirement of Section 15.203/212.

UL Japan, Inc.

Ise EMC Lab.

4383-326 Asama-cho, Ise-shi, Mie-ken 516-0021 JAPAN

Telephone : +81 596 24 8999

Facsimile : +81 596 24 8124

3.3 Addition to standard

Item	Test Procedure	Specification	Worst margin	Results	Remarks
99% Occupied Bandwidth	IC: RSS-Gen 6.6	IC: -	N/A	-	Conducted

Other than above, no addition, exclusion nor deviation has been made from the standard.

3.4 Uncertainty

EMI

The following uncertainties have been calculated to provide a confidence level of 95 % using a coverage factor $k = 2$.
Ise EMC Lab.

Antenna terminal test Uncertainty (+/-)							
Power meter		Conducted emission and Power density			Conducted emission		Channel power
Below 1 GHz	Above 1 GHz	Below 1 GHz	1 GHz - 3 GHz	3 GHz - 18 GHz	18 GHz - 26.5 GHz	26.5 GHz - 40 GHz	
0.9 dB	1.0 dB	1.4 dB	1.7 dB	2.8 dB	2.8 dB	2.9 dB	

Frequency range	Conducted emission using AMN(LISN) (+dB)
0.009 – 0.15MHz	3.5 dB
0.15 – 30MHz	2.9 dB

Test distance	Radiated emission (+dB) 9 kHz - 30 MHz
3m	3.8 dB
10m	3.7 dB

Polarity	Radiated emission (Below 1GHz)			
	(3 m*)(+dB)		(10 m*)(+dB)	
	30 – 200 MHz	200 – 1000MHz	30 – 200 MHz	200 – 1000MHz
Horizontal	4.9 dB	5.2 dB	4.9 dB	5.0 dB
Vertical	4.6 dB	5.9 dB	5.0 dB	5.0 dB

Radiated emission				
(3 m*)(+dB)		(1 m*)(+dB)	(0.5 m*)(+dB)	(10 m*)(+dB)
1 – 6GHz	6 – 18GHz	10 – 26.5 GHz	26.5 – 40GHz	1 -18 GHz
5.1 dB	5.3 dB	5.1 dB	5.1 dB	5.3 dB

*Measurement distance

Conducted Emission test

The data listed in this test report has enough margin, more than the site margin.

Radiated emission test

The data listed in this report meets the limits unless the uncertainty is taken into consideration.

3.5 Test Location

UL Japan, Inc. Ise EMC Lab. *NVLAP Lab. code: 200572-0
4383-326 Asama-cho, Ise-shi, Mie-ken 516-0021 JAPAN
Telephone: +81 596 24 8999, Facsimile: +81 596 24 8124

Test site	IC Registration Number	Width x Depth x Height (m)	Size of reference ground plane (m) / horizontal conducting plane	Other rooms	Maximum measurement distance
No.1 semi-anechoic chamber	2973C-1	19.2 x 11.2 x 7.7	7.0 x 6.0	No.1 Power source room	10 m
No.2 semi-anechoic chamber	2973C-2	7.5 x 5.8 x 5.2	4.0 x 4.0	-	3 m
No.3 semi-anechoic chamber	2973C-3	12.0 x 8.5 x 5.9	6.8 x 5.75	No.3 Preparation room	3 m
No.3 shielded room	-	4.0 x 6.0 x 2.7	N/A	-	-
No.4 semi-anechoic chamber	2973C-4	12.0 x 8.5 x 5.9	6.8 x 5.75	No.4 Preparation room	3 m
No.4 shielded room	-	4.0 x 6.0 x 2.7	N/A	-	-
No.5 semi-anechoic chamber	-	6.0 x 6.0 x 3.9	6.0 x 6.0	-	-
No.6 shielded room	-	4.0 x 4.5 x 2.7	4.0 x 4.5	-	-
No.6 measurement room	-	4.75 x 5.4 x 3.0	4.75 x 4.15	-	-
No.7 shielded room	-	4.7 x 7.5 x 2.7	4.7 x 7.5	-	-
No.8 measurement room	-	3.1 x 5.0 x 2.7	N/A	-	-
No.9 measurement room	-	8.8 x 4.6 x 2.8	2.4 x 2.4	-	-
No.11 measurement room	-	6.2 x 4.7 x 3.0	4.8 x 4.6	-	-

* Size of vertical conducting plane (for Conducted Emission test) : 2.0 m x 2.0m for No.1, No.2, No.3, and No.4 semi-anechoic chambers and No.3 and No.4 shielded rooms.

3.6 Test data, Test instruments, and Test set up

Refer to APPENDIX.

UL Japan, Inc.

Ise EMC Lab.

4383-326 Asama-cho, Ise-shi, Mie-ken 516-0021 JAPAN

Telephone : +81 596 24 8999

Facsimile : +81 596 24 8124

SECTION 4: Operation of E.U.T. during testing

4.1 Operating Mode(s)

Test operating mode was determined as follows according to “Section 1 of 6 802.11 a/b/g/n testing - Managing Complex Regulatory Approvals - ” of TCB Council Workshop October 2009.

Mode	Remarks*
IEEE 802.11b (11b)	11 Mbps, PN9
IEEE 802.11g (11g)	6 Mbps, PN9
IEEE 802.11n SISO 20 MHz BW (11n-20)	MCS 5, PN9
*The worst condition was determined based on the test result of Maximum Peak Output Power (Mid Channel)	
*Power of the EUT was set by the software as follows; Power settings: 11b: 17dBm, 11g: 13dBm, 11n-20: 12dBm Software: WICED-SDK-3.5.1	
*This setting of software is the worst case. Any conditions under the normal use do not exceed the condition of setting. In addition, end users cannot change the settings of the output power of the product.	

*The details of Operating mode(s)

Test Item	Operating Mode	Tested frequency
Conducted Emission, Radiated Spurious Emission (Below 1 GHz), Conducted Spurious Emission	11g Tx *1)	2412 MHz
Radiated Spurious Emission (Above 1 GHz)	11b Tx	2412 MHz
	11g Tx *2)	2437 MHz 2462 MHz
	11n-20 Tx *3)	2412 MHz 2462 MHz
6dB Bandwidth, Maximum Peak Output Power, Power Density, 99% Occupied Bandwidth	11b Tx 11g Tx 11n-20 Tx	2412 MHz 2437 MHz 2462 MHz
*1) The mode was tested as a representative, because it had the highest power at antenna terminal test. *2) Since 11g and 11n-20 have the same modulation method and no differences in transmitting specification, test was performed on the representative mode that had the highest peak output power *3) Only band edge test was tested on this mode, because the 11g Tx mode had the higher power at antenna terminal test.		

4.2 Configuration and peripherals

[Conducted emission test]

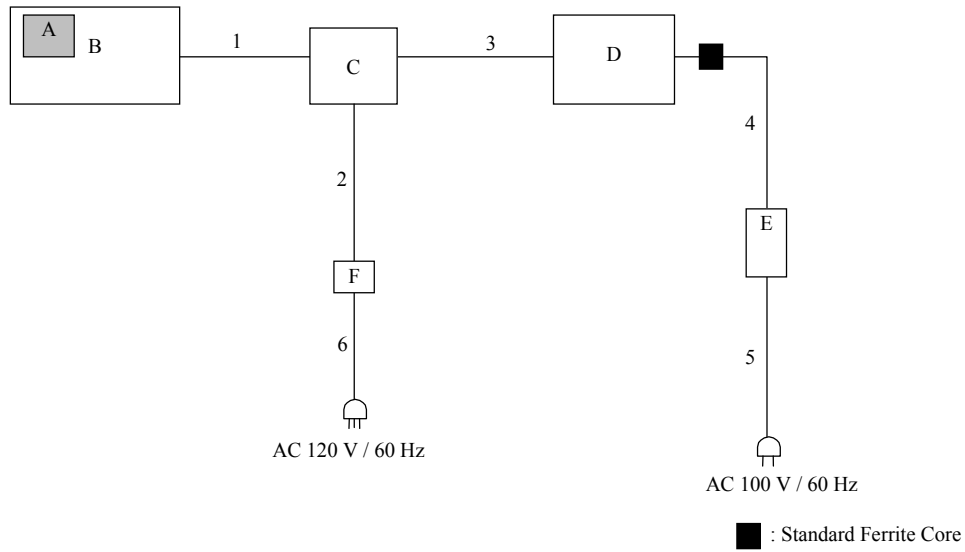

[Radiated emission test]

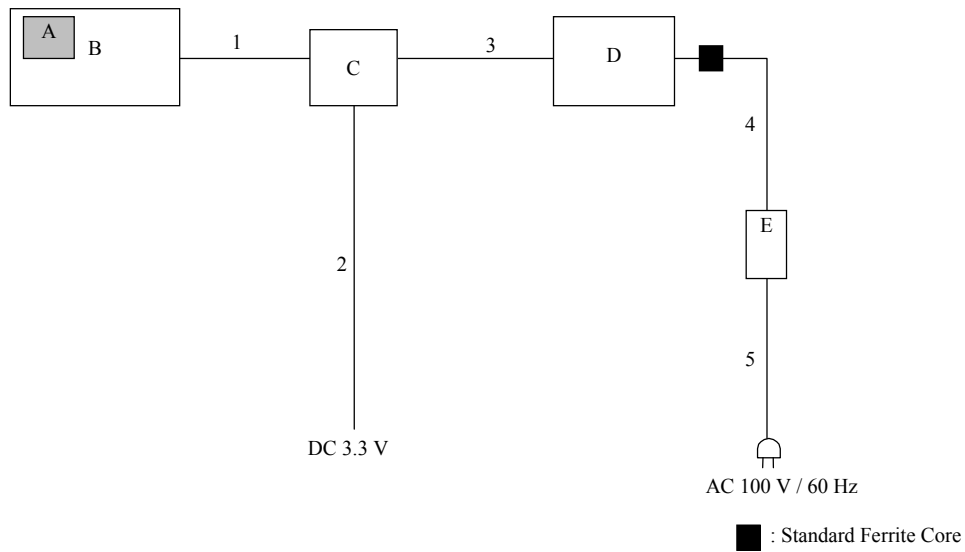

* Cabling and setup(s) were taken into consideration and test data was taken under worse case conditions.

Description of EUT

No.	Item	Model number	Serial number	Manufacturer	Remarks
A	Communication Module	Type1HD	3 *1) 26 *2)	Murata Manufacturing Co., Ltd.	EUT
B	Jig Board	-	-	Murata Manufacturing Co., Ltd.	*3)
C	Jig Board	-	-	Murata Manufacturing Co., Ltd.	-
D	Laptop PC	CF-N8	9LKSA04645	Panasonic	-
E	AC Adapter	CF-AA6372B	6372BM610214975E	Panasonic	-
F	DC power supply	PW18-1.3AT	08016530	KENWOOD TMI	-

*1) Used for Antenna Terminal conducted test

*2) Used for Conducted Emission test and Radiated Emission test

*3) The use of a jig does not influence on the test result.

List of cables used

No.	Name	Length (m)	Shield		Remarks
			Cable	Connector	
1	DC and Signal Cable	0.15	Unshielded	Unshielded	-
2	DC Cable	1.40	Unshielded	Unshielded	-
3	USB Cable	3.70	Shielded	Shielded	-
4	DC Cable	1.00	Unshielded	Unshielded	-
5	AC Cable	0.80	Unshielded	Unshielded	-
6	AC Cable	1.80	Unshielded	Unshielded	-

UL Japan, Inc.

Ise EMC Lab.

4383-326 Asama-cho, Ise-shi, Mie-ken 516-0021 JAPAN

Telephone : +81 596 24 8999

Facsimile : +81 596 24 8124

SECTION 5: Conducted Emission

Test Procedure and conditions

EUT was placed on a urethane platform of nominal size, 1.0 m by 1.5 m, raised 0.8 m above the conducting ground plane.

The rear of tabletop was located 40 cm to the vertical conducting plane. The rear of EUT, including peripherals aligned and flushed with rear of tabletop. All other surfaces of tabletop were at least 80cm from any other grounded conducting surface. EUT was located 80 cm from a Line Impedance Stabilization Network (LISN) / Artificial mains Network (AMN) and excess AC cable was bundled in center.

For the tests on EUT with other peripherals (as a whole system)

I/O cables that were connected to the peripherals were bundled in center. They were folded back and forth forming a bundle 30 cm to 40 cm long and were hanged at a 40 cm height to the ground plane. All unused 50ohm connectors of the LISN (AMN) were resistivity terminated in 50 ohm when not connected to the measuring equipment.

The AC Mains Terminal Continuous disturbance Voltage has been measured with the EUT in a Semi Anechoic Chamber.

The EUT was connected to a LISN (AMN).

An overview sweep with peak detection has been performed.

The test results and limit are rounded off to one decimal place, so some differences might be observed.

Detector : QP and CISPR AV
Measurement range : 0.15 MHz – 30 MHz
Test data : APPENDIX
Test result : Pass

SECTION 6: Radiated Spurious Emission

Test Procedure

It was measured based on "11.0 Emissions in non-restricted frequency bands" of "558074 D01 DTS Meas Guidance v03r05".

[For below 1GHz]

EUT was placed on a urethane platform of nominal size, 0.5 m by 1.0 m, raised 0.8 m above the conducting ground plane. The Radiated Electric Field Strength has been measured in a Semi Anechoic Chamber with a ground plane.

[For above 1GHz]

EUT was placed on a urethane platform of nominal size, 0.5 m by 0.5 m, raised 1.5 m above the conducting ground plane.

The Radiated Electric Field Strength has been measured in a Semi Anechoic Chamber with absorbent materials lined on a ground plane.

The height of the measuring antenna varied between 1 and 4 m and EUT was rotated a full revolution in order to obtain the maximum value of the electric field strength.

The measurements were performed for both vertical and horizontal antenna polarization with the Test Receiver, or the Spectrum Analyzer.

The measurements were made with the following detector function of the test receiver and the Spectrum analyzer (in linear mode).

The test was made with the detector (RBW/VBW) in the following table.

When using Spectrum analyzer, the test was made with adjusting span to zero by using peak hold.

Test Antennas are used as below;

Frequency	30 MHz to 200 MHz	200 MHz to 1 GHz	Above 1 GHz
Antenna Type	Biconical	Logperiodic	Horn

In any 100 kHz bandwidth outside the restricted band in which the spread spectrum intentional radiator is operating, the radio frequency power that is produced by the intentional radiator confirmed 20 dB below that in the 100 kHz bandwidth within the band that contains the highest level of the desired power, based on a radiated measurement.

20 dBc was applied to the frequency over the limit of FCC 15.209 / Table 4 of RSS-Gen 8.9(IC) and outside the restricted band of FCC15.205 / Table 6 of RSS-Gen 8.10 (IC).

Frequency	Below 1 GHz	Above 1 GHz		20 dBc
Instrument used	Test Receiver	Spectrum Analyzer		Spectrum Analyzer
Detector	QP	PK	AV *3)	PK
IF Bandwidth	BW 120 kHz	RBW: 1 MHz VBW: 3 MHz	Average Power Method: <u>12.2.5.1 (11b / 11g)</u> RBW: 1 MHz VBW: 3 MHz Detector: Power Averaging (RMS) Trace: 100 traces <u>12.2.5.2 (11n-20)</u> RBW: 1 MHz VBW: 3 MHz Detector: Power Averaging (RMS) Trace: 100 traces Duty factor was added to the results.	RBW: 100 kHz VBW: 300kHz
Test Distance	3m	4.5 m *1) (1 GHz – 10 GHz), 1 m *2) (10 GHz – 26.5 GHz)		4.5 m *1) (1 GHz – 10 GHz), 1 m *2) (10 GHz – 26.5 GHz)

*1) Distance Factor: $20 \times \log(4.5 \text{ m} / 3.0 \text{ m}) = 3.5 \text{ dB}$

*2) Distance Factor: $20 \times \log(1.0 \text{ m} / 3.0 \text{ m}) = -9.5 \text{ dB}$

*3) Average Power Measurement was performed based on 6.0 & 12.2.5 of "KDB 558074 D01 DTS Meas Guidance v03r05"

- The carrier level and noise levels were confirmed at each position of X, Y and Z axes of EUT to see the position of maximum noise, and the test was made at the position that has the maximum noise.

The test results and limit are rounded off to one decimal place, so some differences might be observed.

Measurement range : 30 M - 26.5 GHz
Test data : APPENDIX
Test result : Pass

UL Japan, Inc.

Ise EMC Lab.

4383-326 Asama-cho, Ise-shi, Mie-ken 516-0021 JAPAN

Telephone : +81 596 24 8999

Facsimile : +81 596 24 8124

SECTION 7: Antenna Terminal Conducted Tests

Test Procedure

The tests were made with below setting connected to the antenna port.

Test	Span	RBW	VBW	Sweep time	Detector	Trace	Instrument used
6dB Bandwidth	20 MHz	100 kHz	300 kHz	Auto	Peak	Max Hold	Spectrum Analyzer
99% Occupied Bandwidth *1)	Enough width to display emission skirts	1 to 5 % of OBW	Three times of RBW	Auto	Peak	Max Hold	Spectrum Analyzer
Maximum Peak Output Power	-	-	-	Auto	Peak/ Average *2)	-	Power Meter (Sensor: 50 MHz BW)
Peak Power Density	1.5 times the 6dB Bandwidth	3 kHz	10 kHz	Auto	Peak	Max Hold	Spectrum Analyzer *3)
Conducted Spurious Emission *4)	9kHz to 150kHz	200 Hz	620 Hz	Auto	Peak	Max Hold	Spectrum Analyzer
	150kHz to 30MHz	9.1 kHz	27 kHz				

*1) Peak hold was applied as Worst-case measurement.

*2) Reference data

*3) Section 10.2 Method PKPSD (peak PSD) of "KDB 558074 D01 DTS Meas Guidance v03r05".

*4) In the frequency range below 30MHz, RBW was narrowed to separate the noise contents.

Then, wide-band noise near the limit was checked separately, however the noise was not detected as shown in the chart.

(9 kHz - 150 kHz: RBW = 200 Hz, 150 kHz - 30 MHz: RBW = 9.1 kHz)

The test results and limit are rounded off to two decimals place, so some differences might be observed.

Test data : **APPENDIX**
Test result : **Pass**

APPENDIX 1: Test data

Conducted Emission

DATA OF CONDUCTED EMISSION TEST

UL Japan, Inc. Ise EMC Lab. No.4 Semi Anechoic Chamber
Date : 2016/05/12

Report No. : 11219693H

Temp./Humi. : 22deg. C / 54% RH
Engineer : Kazuya Yoshioka

Mode / Remarks : WLAN 11g 2412MHz

LIMIT : FCC15.207 QP
FCC15.207 AV

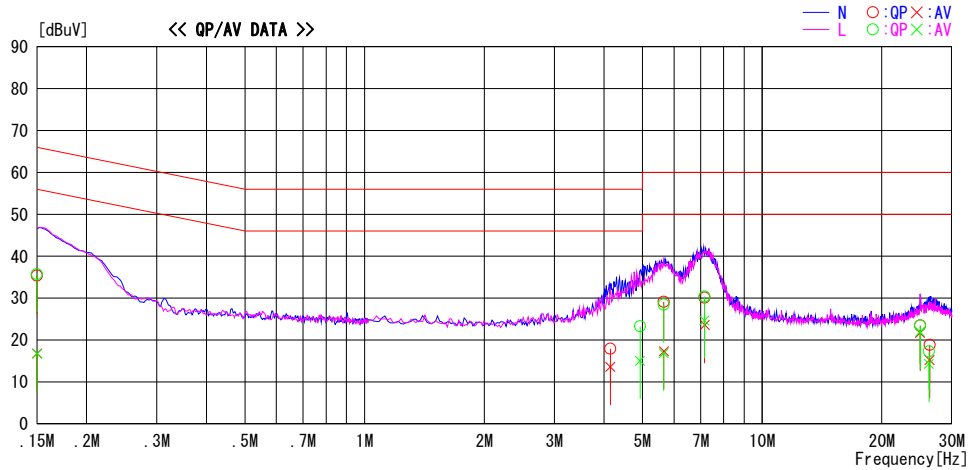

Frequency [MHz]	Reading Level		Corr. Factor [dB]	Results		Limit		Margin		Phase	Comment
	QP [dBuV]	AV [dBuV]		QP [dBuV]	AV [dBuV]	QP [dBuV]	AV [dBuV]	QP [dB]	AV [dB]		
0.15000	22.0	3.4	13.4	35.4	16.8	66.0	56.0	30.6	39.2	N	
4.15122	4.2	-0.1	13.7	17.9	13.6	56.0	46.0	38.1	32.4	N	
5.65811	15.2	3.5	13.9	29.1	17.4	60.0	50.0	30.9	32.6	N	
7.16512	16.2	9.7	13.9	30.1	23.6	60.0	50.0	29.9	26.4	N	
24.95711	8.7	6.9	14.8	23.5	21.7	60.0	50.0	36.5	28.3	N	
26.38410	4.0	0.4	14.8	18.8	15.2	60.0	50.0	41.2	34.8	N	
0.15000	22.3	3.4	13.4	35.7	16.8	66.0	56.0	30.3	39.2	L	
4.93200	9.5	1.3	13.8	23.3	15.1	56.0	46.0	32.7	30.9	L	
5.65120	14.6	3.0	13.9	28.5	16.9	60.0	50.0	31.5	33.1	L	
7.15822	16.5	10.8	13.9	30.4	24.7	60.0	50.0	29.6	25.3	L	
24.95740	8.7	7.2	14.8	23.5	22.0	60.0	50.0	36.5	28.0	L	
26.25441	2.5	-0.5	14.8	17.3	14.3	60.0	50.0	42.7	35.7	L	

CHART : WITH FACTOR, Peak hold data. CALCULATION : RESULT = READING + C.F (LISN + ATTN + CABLE)
Except for the above table : adequate margin data below the limits.

6dB Bandwidth

Test place Ise EMC Lab. No.6 Measurement Room
Report No. 11219693H
Date March 31, 2016 May 11, 2016
Temperature / Humidity 23 deg. C / 45 % RH 26 deg. C / 50 % RH
Engineer Shinichi Miyazono Takafumi Noguchi
Mode Tx

Mode	Frequency [MHz]	6dB Bandwidth [MHz]	Limit [kHz]
11b	2412	8.650	> 500
	2437	8.666	> 500
	2462	8.387	> 500
11g	2412	15.798	> 500
	2437	15.658	> 500
	2462	15.818	> 500
11n-20	2412	17.199	> 500
	2437	17.320	> 500
	2462	17.248	> 500

6dB Bandwidth

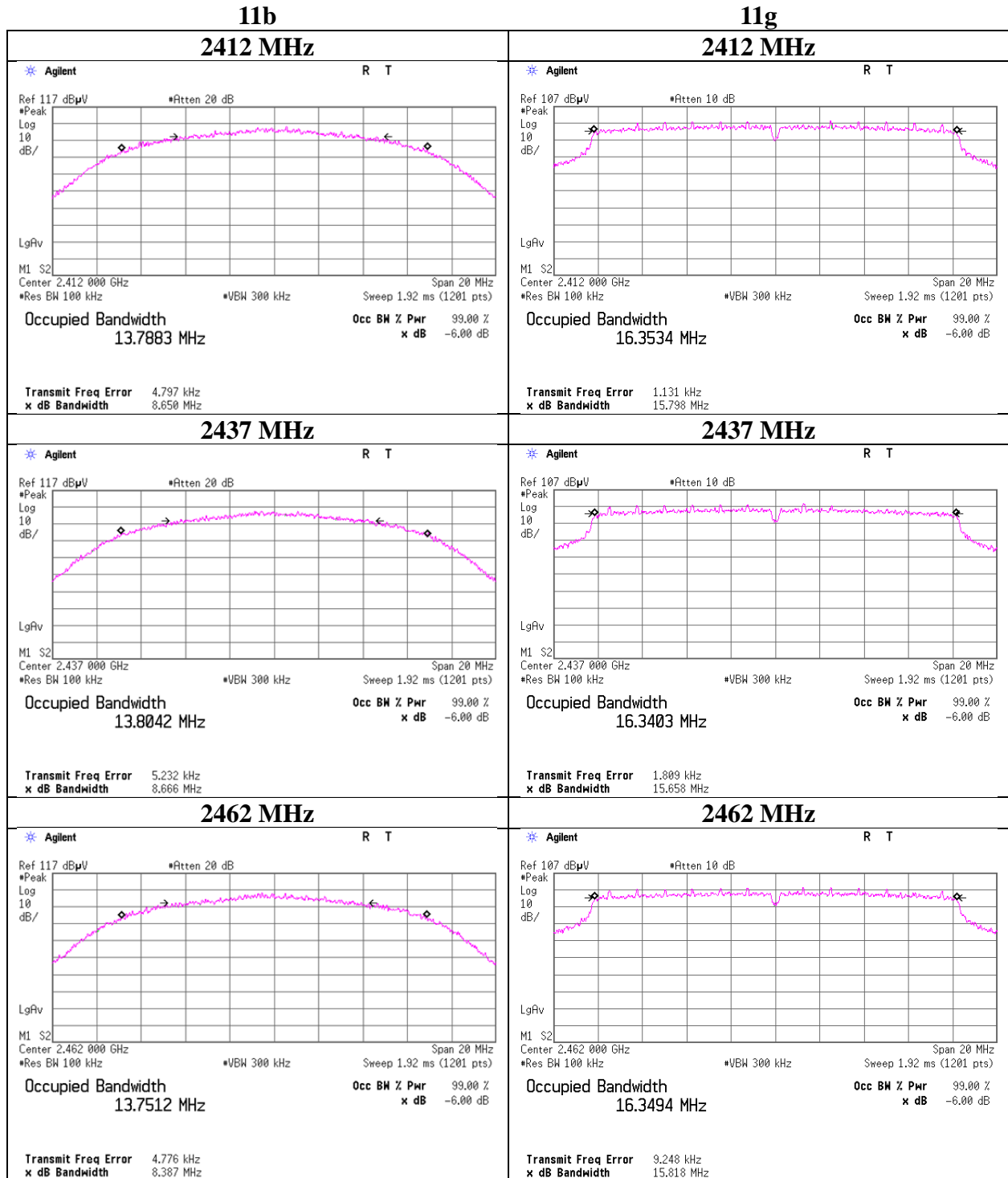

6dB Bandwidth

11n-20

2412 MHz

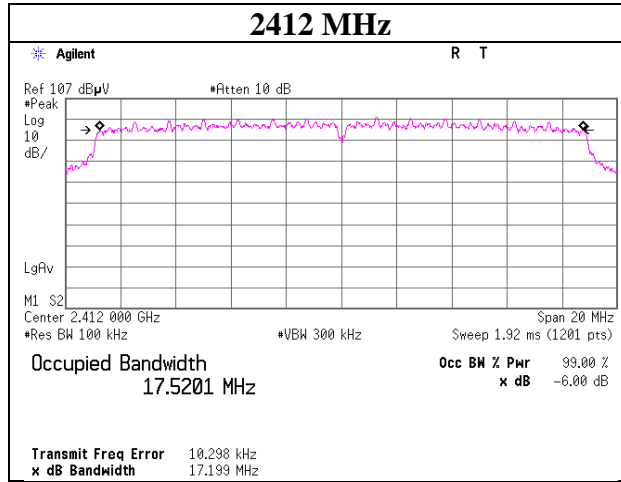

2437 MHz

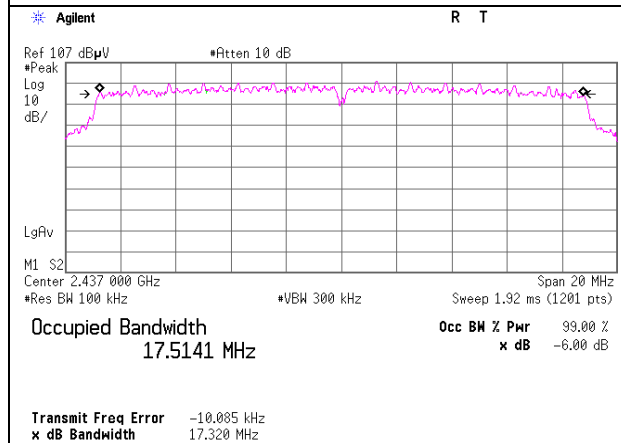

2462 MHz

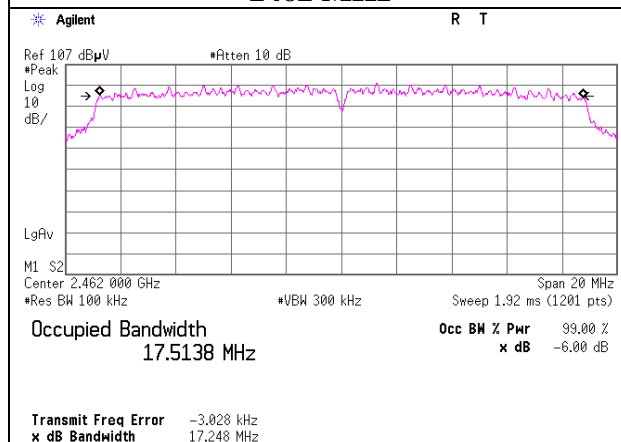

UL Japan, Inc.

Ise EMC Lab.

4383-326 Asama-cho, Ise-shi, Mie-ken 516-0021 JAPAN

Telephone : +81 596 24 8999

Facsimile : +81 596 24 8124

Maximum Peak Output Power

Test place	Ise EMC Lab. No.6 Measurement Room
Report No.	11219693H
Date	March 30, 2016
Temperature / Humidity	23 deg. C / 34 % RH
Engineer	Hiroyuki Furutaka
Mode	Tx 11b

Freq. [MHz]	Reading [dBm]	Cable Loss [dB]	Atten. Loss [dB]	Result		Limit		Margin [dB]
				[dBm]	[mW]	[dBm]	[mW]	
2412	8.73	1.97	10.08	20.78	119.67	30.00	1000	9.22
2437	8.80	1.98	10.08	20.86	121.90	30.00	1000	9.14
2462	8.78	1.99	10.08	20.85	121.62	30.00	1000	9.15

Sample Calculation:

Result = Reading + Cable Loss (including the cable(s) customer supplied) + Attenuator Loss

2437MHz

Rate	Reading	Remark
[Mbps]	[dBm]	
1	8.34	
2	8.52	
5.5	8.54	
11	8.80	*

*: Worst Rate

All comparison were carried out on same frequency and measurement factors.

Maximum Peak Output Power

Test place	Ise EMC Lab. No.6 Measurement Room	
Report No.	11219693H	
Date	March 30, 2016	May 11, 2016
Temperature / Humidity	23 deg. C / 34 % RH	26 deg. C / 50 % RH
Engineer	Hiroyuki Furutaka	Takafumi Noguchi
Mode	Tx 11g	

Freq. [MHz]	Reading [dBm]	Cable Loss [dB]	Atten. Loss [dB]	Result		Limit		Margin [dB]
				[dBm]	[mW]	[dBm]	[mW]	
2412	14.78	1.64	9.54	25.96	394.46	30.00	1000	4.04
2437	14.65	1.65	9.54	25.84	383.71	30.00	1000	4.16
2462	14.60	1.65	9.54	25.79	379.31	30.00	1000	4.21

Sample Calculation:

Result = Reading + Cable Loss (including the cable(s) customer supplied) + Attenuator Loss

2437 MHz

Rate [Mbps]	Reading [dBm]	Remark
6	13.74	*
9	13.44	
12	13.21	
18	12.83	
24	13.05	
36	13.30	
48	13.15	
54	12.58	

*: Worst Rate

All comparison were carried out on same frequency and measurement factors.

Maximum Peak Output Power

Test place	Ise EMC Lab. No.6 Measurement Room	
Report No.	11219693H	
Date	March 30, 2016	May 11, 2016
Temperature / Humidity	23 deg. C / 34 % RH	26 deg. C / 50 % RH
Engineer	Hiroyuki Furutaka	Takafumi Noguchi
Mode	Tx 11n-20	

Freq. [MHz]	Reading [dBm]	Cable Loss [dB]	Atten. Loss [dB]	Result		Limit		Margin [dB]
				[dBm]	[mW]	[dBm]	[mW]	
2412	14.06	1.64	9.54	25.24	334.20	30.00	1000	4.76
2437	13.99	1.65	9.54	25.18	329.61	30.00	1000	4.82
2462	13.97	1.65	9.54	25.16	328.10	30.00	1000	4.84

Sample Calculation:

Result = Reading + Cable Loss (including the cable(s) customer supplied) + Attenuator Loss

2437 MHz

MCS Number	Reading [dBm]	Remark
0	12.87	
1	12.79	
2	12.99	
3	12.33	
4	11.30	
5	13.02*	
6	11.83	
7	11.56	

* Worst MCS

* Worst Condition

All comparison were carried out on same frequency and measurement factors.

Average Output Power
(Reference data for RF Exposure)

Test place	Ise EMC Lab. No.6 Measurement Room
Report No.	11219693H
Date	March 30, 2016
Temperature / Humidity	23 deg. C / 34 % RH
Engineer	Hiroyuki Furutaka
Mode	Tx

11b 11 Mbps

Freq. [MHz]	Reading [dBm]	Cable Loss [dB]	Atten. Loss [dB]	Result (Time average)		Duty factor [dB]	Result (Burst power average)	
				[dBm]	[mW]		[dBm]	[mW]
2412	5.88	1.97	10.08	17.93	62.09	0.07	18.00	63.10
2437	5.89	1.98	10.08	17.95	62.37	0.07	18.02	63.39
2462	5.85	1.99	10.08	17.92	61.94	0.07	17.99	62.95

11g 6 Mbps

Freq. [MHz]	Reading [dBm]	Cable Loss [dB]	Atten. Loss [dB]	Result (Time average)		Duty factor [dB]	Result (Burst power average)	
				[dBm]	[mW]		[dBm]	[mW]
2412	2.58	1.64	9.54	13.76	23.77	0.05	13.81	24.04
2437	2.54	1.65	9.54	13.73	23.60	0.05	13.78	23.88
2462	2.48	1.65	9.54	13.67	23.28	0.05	13.72	23.55

11n-20 MCS 5

Freq. [MHz]	Reading [dBm]	Cable Loss [dB]	Atten. Loss [dB]	Result (Time average)		Duty factor [dB]	Result (Burst power average)	
				[dBm]	[mW]		[dBm]	[mW]
2412	1.15	1.64	9.54	12.33	17.10	0.43	12.76	18.88
2437	1.13	1.65	9.54	12.32	17.06	0.43	12.75	18.84
2462	1.10	1.65	9.54	12.29	16.94	0.43	12.72	18.71

Sample Calculation:

Result (Time average) = Reading + Cable Loss (including the cable(s) customer supplied) + Attenuator

Result (Burst power average) = Time average + Duty factor

Burst rate confirmation

Test place Ise EMC Lab. No.6 Measurement Room
 Report No. 11219693H
 Date March 30, 2016 May 11, 2016
 Temperature / Humidity 23 deg. C / 34 % RH 26 deg. C / 50 % RH
 Engineer Hiroyuki Furutaka Takafumi Noguchi
 Mode Tx

11b 11 Mbps

11g 6 Mbps

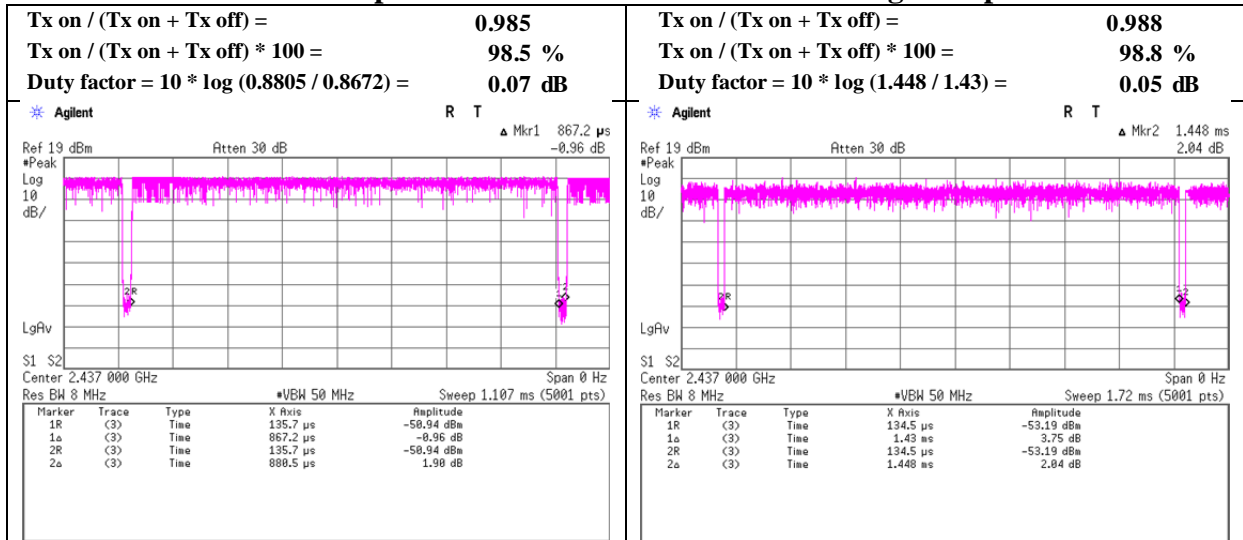

11n-20 MCS 5

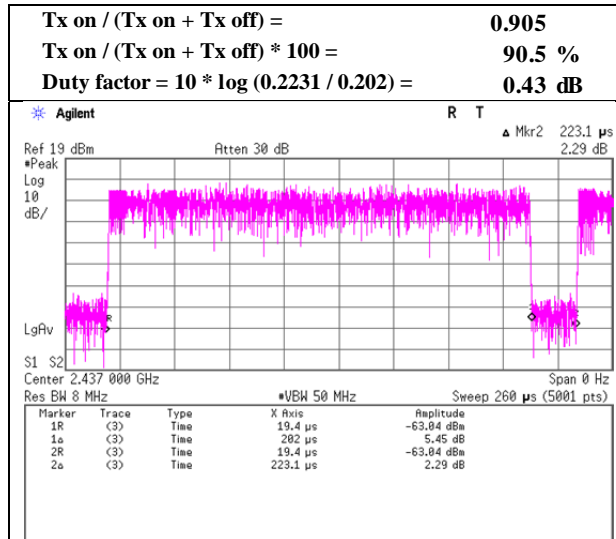

Radiated Spurious Emission

Test place : Ise EMC Lab. No.3 Semi Anechoic Chamber
Report No. : 11219693H
Date : April 1, 2016 April 2, 2016
Temperature / Humidity : 21 deg. C / 31 % RH 21 deg. C / 31 % RH
Engineer : Yuta Moriya Yuta Moriya
 (1-10GHz) (Above 10GHz)
Mode : Tx 11b 2412 MHz

Polarity	Frequency [MHz]	Detector	Reading [dBuV]	Ant.Fac. [dB/m]	Loss [dB]	Gain [dB]	Result [dBuV/m]	Limit [dBuV/m]	Margin [dB]	Remark
Hori	2390.000	PK	56.6	26.9	6.8	32.7	57.6	73.9	16.3	
Hori	3618.042	PK	42.8	29.4	8.9	32.1	49.0	73.9	24.9	
Hori	4824.000	PK	40.9	31.8	8.1	31.8	49.0	73.9	24.9	Floor noise
Hori	7236.000	PK	40.2	36.0	8.8	32.6	52.4	73.9	21.5	Floor noise
Hori	9648.000	PK	40.4	38.2	9.6	33.3	54.9	73.9	19.0	Floor noise
Hori	2390.000	AV	47.0	26.9	6.8	32.7	48.0	53.9	5.9	
Hori	3618.042	AV	36.1	29.4	8.9	32.1	42.3	53.9	11.6	
Hori	4824.000	AV	30.1	31.8	8.1	31.8	38.2	53.9	15.7	Floor noise
Hori	7236.000	AV	32.0	36.0	8.8	32.6	44.2	53.9	9.7	Floor noise
Hori	9648.000	AV	32.1	38.2	9.6	33.3	46.6	53.9	7.3	Floor noise
Vert	2390.000	PK	53.2	26.9	6.8	32.7	54.2	73.9	19.7	
Vert	3618.042	PK	42.7	29.4	8.9	32.1	48.9	73.9	25.0	
Vert	4824.000	PK	41.0	31.8	8.1	31.8	49.1	73.9	24.8	Floor noise
Vert	7236.000	PK	40.1	36.0	8.8	32.6	52.3	73.9	21.6	Floor noise
Vert	9648.000	PK	40.2	38.2	9.6	33.3	54.7	73.9	19.2	Floor noise
Vert	2390.000	AV	43.9	26.9	6.8	32.7	44.9	53.9	9.0	
Vert	3618.042	AV	36.7	29.4	8.9	32.1	42.9	53.9	11.0	
Vert	4824.000	AV	30.2	31.8	8.1	31.8	38.3	53.9	15.6	Floor noise
Vert	7236.000	AV	31.5	36.0	8.8	32.6	43.7	53.9	10.2	Floor noise
Vert	9648.000	AV	32.0	38.2	9.6	33.3	46.5	53.9	7.4	Floor noise

Result = Reading + Ant Factor + Loss (Cable+Attenuator+Filter+Distance factor(above 1 GHz)) - Gain(Amplifier)

*Other frequency noises omitted in this report were not seen or had enough margin (more than 20 dB).

Distance factor: 1 GHz - 10 GHz 20log (4.5 m / 3.0 m) = 3.5 dB
 10 GHz - 26.5 GHz 20log (1.0 m / 3.0 m) = -9.5 dB

20dBc Data Sheet

Polarity	Frequency [MHz]	Detector	Reading [dBuV]	Ant Factor [dB/m]	Loss [dB]	Gain [dB]	Result [dBuV/m]	Limit [dBuV/m]	Margin [dB]	Remark
Hori	2412.000	PK	104.8	26.9	6.8	32.7	105.8	-	-	Carrier
Hori	2400.000	PK	65.1	26.9	6.8	32.7	66.1	85.8	19.7	
Vert	2412.000	PK	103.5	26.9	6.8	32.7	104.5	-	-	Carrier
Vert	2400.000	PK	60.6	26.9	6.8	32.7	61.6	84.5	22.9	

Result = Reading + Ant Factor + Loss (Cable+Attenuator+Filter+Distance factor(above 1 GHz)) - Gain(Amplifier)

Radiated Spurious Emission (Reference Plot for band-edge)

Test place	Ise EMC Lab. No.3 Semi Anechoic Chamber
Report No.	11219693H
Date	April 1, 2016
Temperature / Humidity	21 deg. C / 31 % RH
Engineer	Yuta Moriya
Mode	Tx 11b 2412 MHz

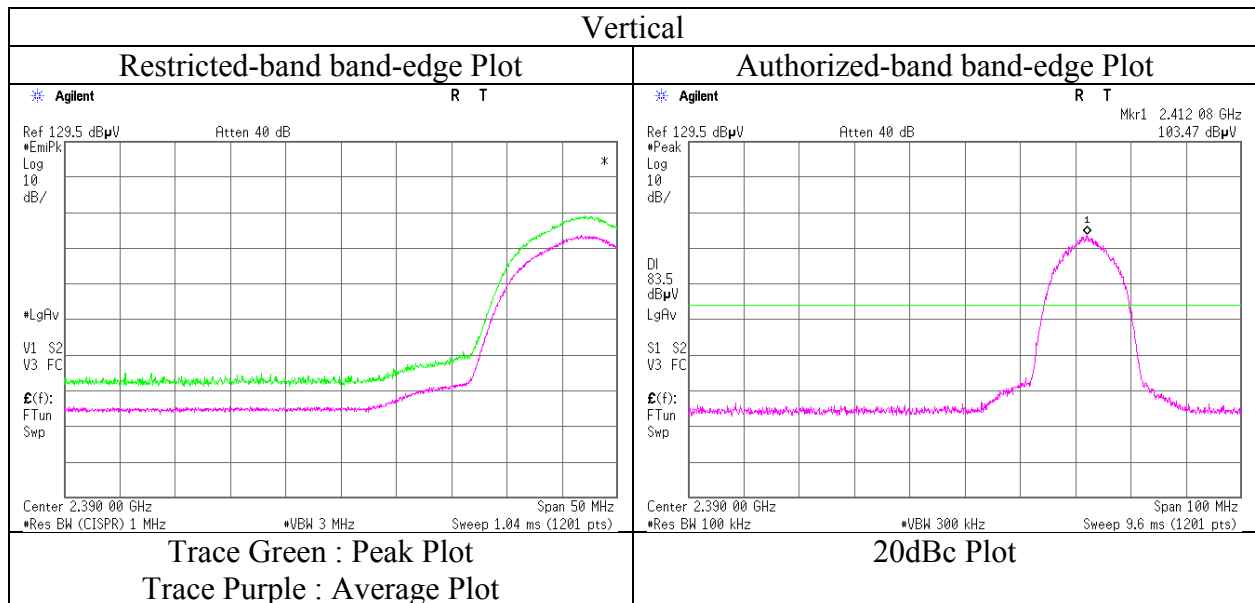
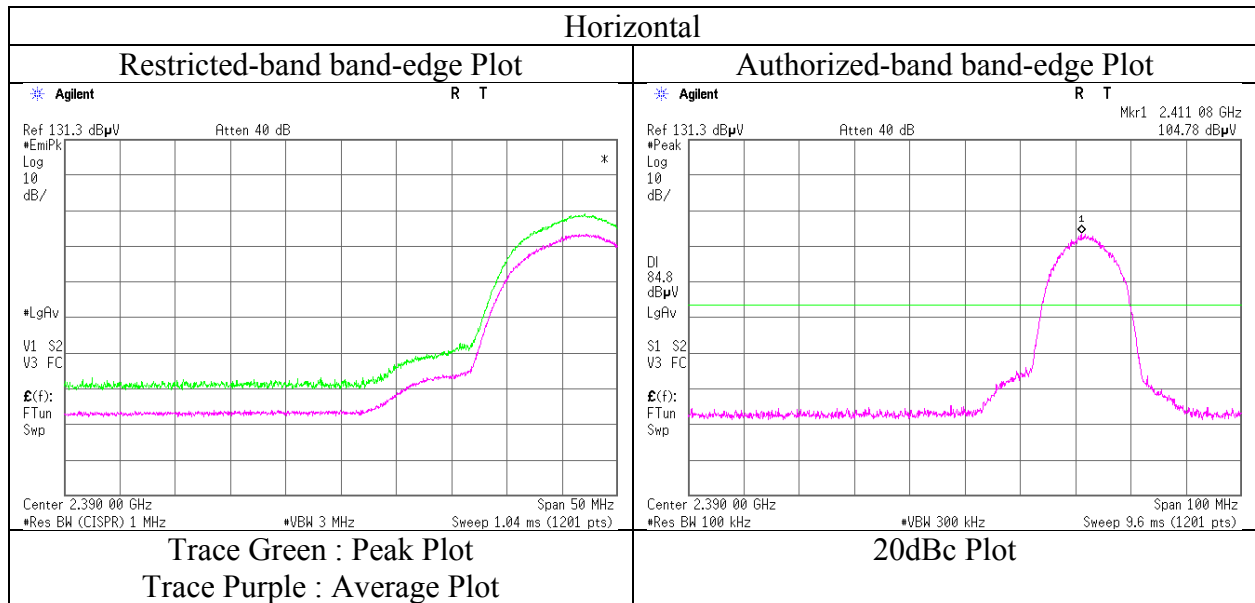

* Final result of restricted band edge was shown in tabular data.

UL Japan, Inc.

Ise EMC Lab.

4383-326 Asama-cho, Ise-shi, Mie-ken 516-0021 JAPAN

Telephone : +81 596 24 8999

Facsimile : +81 596 24 8124

Radiated Spurious Emission

Test place : Ise EMC Lab. No.3 Semi Anechoic Chamber
Report No. : 11219693H
Date : April 1, 2016 April 2, 2016
Temperature / Humidity : 21 deg. C / 31 % RH 21 deg. C / 31 % RH
Engineer : Yuta Moriya Yuta Moriya
 (1-10GHz) (Above 10GHz)
Mode : Tx 11b 2437 MHz

Polarity	Frequency [MHz]	Detector	Reading [dBuV]	Ant.Fac. [dB/m]	Loss [dB]	Gain [dB]	Result [dBuV/m]	Limit [dBuV/m]	Margin [dB]	Remark
Hori	3655.508	PK	42.3	29.4	8.9	32.1	48.5	73.9	25.4	
Hori	4874.000	PK	38.7	31.9	8.1	31.7	47.0	73.9	26.9	Floor noise
Hori	7311.000	PK	40.2	36.0	8.9	32.6	52.5	73.9	21.4	Floor noise
Hori	9748.000	PK	40.5	38.2	9.6	33.3	55.0	73.9	18.9	Floor noise
Hori	3655.508	AV	35.9	29.4	8.9	32.1	42.1	53.9	11.8	
Hori	4874.000	AV	31.2	31.9	8.1	31.7	39.5	53.9	14.4	Floor noise
Hori	7311.000	AV	32.3	36.0	8.9	32.6	44.6	53.9	9.3	Floor noise
Hori	9748.000	AV	32.4	38.2	9.6	33.3	46.9	53.9	7.0	Floor noise
Vert	3655.508	PK	44.1	29.4	8.9	32.1	50.3	73.9	23.6	
Vert	4874.000	PK	39.4	31.9	8.1	31.7	47.7	73.9	26.2	Floor noise
Vert	7311.000	PK	39.9	36.0	8.9	32.6	52.2	73.9	21.7	Floor noise
Vert	9748.000	PK	40.3	38.2	9.6	33.3	54.8	73.9	19.1	Floor noise
Vert	3655.508	AV	37.1	29.4	8.2	32.1	42.6	53.9	11.3	
Vert	4874.000	AV	31.2	31.9	8.1	31.7	39.5	53.9	14.4	Floor noise
Vert	7311.000	AV	31.1	36.0	8.9	32.6	43.4	53.9	10.5	Floor noise
Vert	9748.000	AV	32.1	38.2	9.6	33.3	46.6	53.9	7.3	Floor noise

Result = Reading + Ant Factor + Loss (Cable+Attenuator+Filter+Distance factor(above 1 GHz)) - Gain(Amplifier)

*Other frequency noises omitted in this report were not seen or had enough margin (more than 20 dB).

Distance factor: 1 GHz - 10 GHz 20log (4.5 m / 3.0 m) = 3.5 dB
 10 GHz - 26.5 GHz 20log (1.0 m / 3.0 m) = -9.5 dB

Radiated Spurious Emission

Test place Ise EMC Lab. No.3 Semi Anechoic Chamber
Report No. 11219693H
Date April 1, 2016 April 2, 2016
Temperature / Humidity 21 deg. C / 31 % RH 21 deg. C / 31 % RH
Engineer Yuta Moriya Yuta Moriya
(1-10GHz) (Above 10GHz)
Mode Tx 11b 2462 MHz

Polarity	Frequency [MHz]	Detector	Reading [dBuV]	Ant.Fac. [dB/m]	Loss [dB]	Gain [dB]	Result [dBuV/m]	Limit [dBuV/m]	Margin [dB]	Remark
Hori	2483.500	PK	49.3	26.9	6.8	32.6	50.4	73.9	23.5	
Hori	3692.914	PK	42.0	29.5	8.9	32.1	48.3	73.9	25.6	
Hori	4924.000	PK	38.5	32.0	8.0	31.7	46.8	73.9	27.1	Floor noise
Hori	7386.000	PK	40.6	36.0	8.9	32.7	52.8	73.9	21.1	Floor noise
Hori	9848.000	PK	40.3	38.2	9.6	33.3	54.8	73.9	19.1	Floor noise
Hori	2483.500	AV	41.2	26.9	6.8	32.6	42.3	53.9	11.6	
Hori	3692.914	AV	35.6	29.5	8.9	32.1	41.9	53.9	12.0	
Hori	4924.000	AV	31.4	32.0	8.0	31.7	39.7	53.9	14.2	Floor noise
Hori	7386.000	AV	32.6	36.0	8.9	32.7	44.8	53.9	9.1	Floor noise
Hori	9848.000	AV	32.5	38.2	9.6	33.3	47.0	53.9	6.9	Floor noise
Vert	2483.500	PK	50.2	26.9	6.8	32.6	51.3	73.9	22.6	
Vert	3692.914	PK	43.4	29.5	8.9	32.1	49.7	73.9	24.2	
Vert	4924.000	PK	39.0	32.0	8.0	31.7	47.3	73.9	26.6	Floor noise
Vert	7386.000	PK	39.8	36.0	8.9	32.7	52.0	73.9	21.9	Floor noise
Vert	9848.000	PK	40.6	38.2	9.6	33.3	55.1	73.9	18.8	Floor noise
Vert	2483.500	AV	41.2	26.9	6.8	32.6	42.3	53.9	11.6	
Vert	3692.914	AV	35.5	29.5	8.1	32.1	41.0	53.9	12.9	
Vert	4924.000	AV	31.4	32.0	8.0	31.7	39.7	53.9	14.2	Floor noise
Vert	7386.000	AV	31.3	36.0	8.9	32.7	43.5	53.9	10.4	Floor noise
Vert	9848.000	AV	32.3	38.2	9.6	33.3	46.8	53.9	7.1	Floor noise

Result = Reading + Ant Factor + Loss (Cable+Attenuator+Filter+Distance factor(above 1 GHz)) - Gain(Amplifier)

*Other frequency noises omitted in this report were not seen or had enough margin (more than 20 dB).

Distance factor: 1 GHz - 10 GHz $20\log(4.5\text{ m} / 3.0\text{ m}) = 3.5\text{ dB}$
10 GHz - 26.5 GHz $20\log(1.0\text{ m} / 3.0\text{ m}) = -9.5\text{ dB}$

Radiated Spurious Emission
(Reference Plot for band-edge)

Test place	Ise EMC Lab. No.3 Semi Anechoic Chamber
Report No.	11219693H
Date	April 1, 2016
Temperature / Humidity	21 deg. C / 31 % RH
Engineer	Yuta Moriya
Mode	Tx 11b 2462 MHz

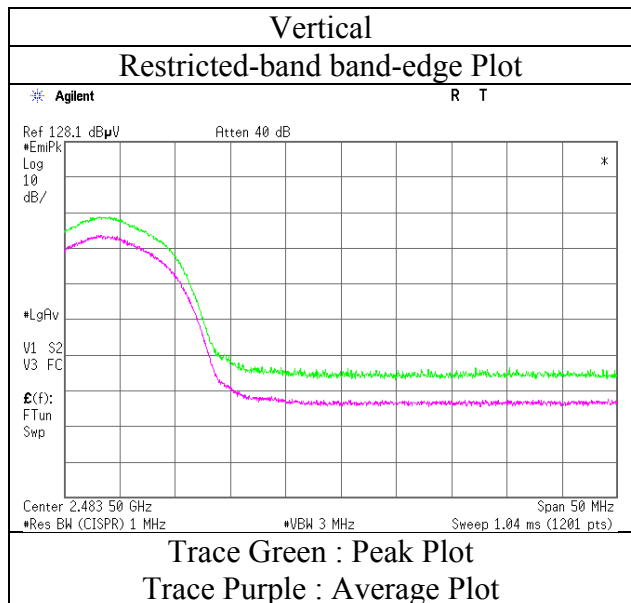
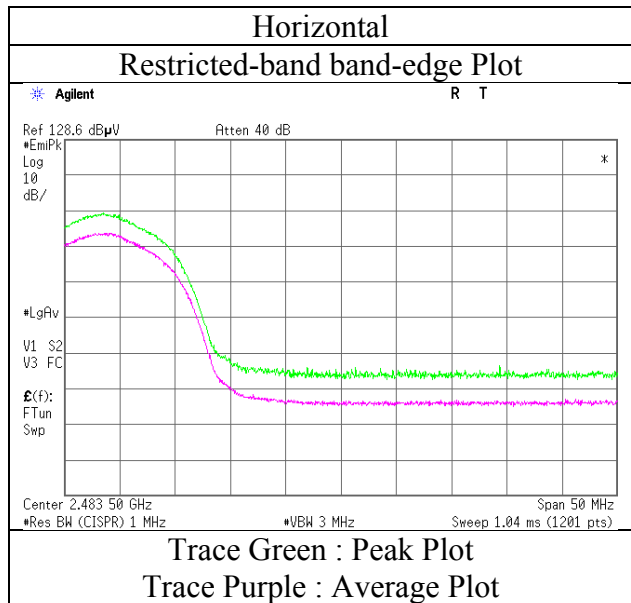

* Final result of restricted band edge was shown in tabular data.

Radiated Spurious Emission

Test place : Ise EMC Lab. No.4 Semi Anechoic Chamber
Report No. : 11219693H
Date : May 11, 2016 May 12, 2016
Temperature / Humidity : 22 deg. C / 54 % RH 22 deg. C / 54 % RH
Engineer : Kazuya Yoshioka Kazuya Yoshioka
(Above 1GHz) (Below 1GHz)
Mode : Tx 11g 2412 MHz

Polarity	Frequency [MHz]	Detector	Reading [dBuV]	Ant.Fac. [dB/m]	Loss [dB]	Gain [dB]	Result [dBuV/m]	Limit [dBuV/m]	Margin [dB]	Remark
Hori	120.006	QP	35.1	12.8	8.3	32.0	24.2	43.5	19.3	
Hori	224.565	QP	42.3	11.7	9.3	31.9	31.4	46.0	14.6	
Hori	249.520	QP	44.5	12.3	9.5	31.9	34.4	46.0	11.6	
Hori	288.588	QP	40.9	13.2	9.8	31.8	32.1	46.0	13.9	
Hori	336.868	QP	39.6	14.3	10.2	31.9	32.2	46.0	13.8	
Hori	349.347	QP	39.8	14.6	10.3	31.9	32.8	46.0	13.2	
Hori	2381.462	PK	62.6	27.9	6.8	32.1	65.2	73.9	8.7	
Hori	2390.000	PK	63.9	27.9	6.8	32.1	66.5	73.9	7.4	
Hori	4824.000	PK	39.3	32.9	9.2	31.3	50.1	73.9	23.8	Floor noise
Hori	7236.000	PK	41.5	36.8	10.4	32.6	56.1	73.9	17.8	Floor noise
Hori	9648.000	PK	42.5	38.1	11.2	32.6	59.2	73.9	14.7	
Hori	2381.462	AV	42.7	27.9	6.8	32.1	45.3	53.9	8.6	
Hori	2390.000	AV	45.9	27.9	6.8	32.1	48.5	53.9	5.4	
Hori	4824.000	AV	28.7	32.9	9.2	31.3	39.5	53.9	14.4	Floor noise
Hori	7236.000	AV	29.7	36.8	10.4	32.6	44.3	53.9	9.6	Floor noise
Hori	9648.000	AV	33.1	38.1	11.2	32.6	49.8	53.9	4.1	
Vert	126.792	QP	36.4	13.4	8.4	32.0	26.2	43.5	17.3	
Vert	224.577	QP	44.4	11.7	9.3	31.9	33.5	46.0	12.5	
Vert	249.532	QP	40.8	12.3	9.5	31.9	30.7	46.0	15.3	
Vert	289.110	QP	40.4	13.2	9.8	31.8	31.6	46.0	14.4	
Vert	336.852	QP	42.9	14.3	10.2	31.9	35.5	46.0	10.5	
Vert	349.339	QP	41.9	14.6	10.3	31.9	34.9	46.0	11.1	
Vert	2387.250	PK	63.6	27.9	6.8	32.1	66.2	73.9	7.7	
Vert	2390.000	PK	64.9	27.9	6.8	32.1	67.5	73.9	6.4	
Vert	4824.000	PK	39.5	32.9	9.2	31.3	50.3	73.9	23.6	Floor noise
Vert	7236.000	PK	41.8	36.8	10.4	32.6	56.4	73.9	17.5	Floor noise
Vert	9648.000	PK	43.5	38.1	11.2	32.6	60.2	73.9	13.7	
Vert	2387.250	AV	42.2	27.9	6.8	32.1	44.8	53.9	9.1	
Vert	2390.000	AV	47.1	27.9	6.8	32.1	49.7	53.9	4.2	
Vert	4824.000	AV	28.7	32.9	9.2	31.3	39.5	53.9	14.4	Floor noise
Vert	7236.000	AV	29.7	36.8	10.4	32.6	44.3	53.9	9.6	Floor noise
Vert	9648.000	AV	33.8	38.1	11.2	32.6	50.5	53.9	3.4	

Result = Reading + Ant Factor + Loss (Cable+Attenuator+Filter+Distance factor(above 1 GHz)) - Gain(Amplifier)

*Other frequency noises omitted in this report were not seen or had enough margin (more than 20 dB).

Distance factor: 1 GHz - 10 GHz 20log (4.5m / 3.0 m) = 3.53 dB
 10 GHz - 26.5 GHz 20log (1.0 m / 3.0 m) = -9.5 dB

20dBc Data Sheet

Polarity	Frequency [MHz]	Detector	Reading [dBuV]	Ant Factor [dB/m]	Loss [dB]	Gain [dB]	Result [dBuV/m]	Limit [dBuV/m]	Margin [dB]	Remark
Hori	2412.000	PK	95.3	28.0	6.8	32.1	98.0	-	-	Carrier
Hori	2400.000	PK	64.7	28.0	6.8	32.1	67.4	78.0	10.6	
Vert	2412.000	PK	95.0	28.0	6.8	32.1	97.7	-	-	Carrier
Vert	2400.000	PK	64.5	28.0	6.8	32.1	67.2	77.7	10.5	

Result = Reading + Ant Factor + Loss (Cable+Attenuator+Filter+Distance factor(above 1 GHz)) - Gain(Amplifier)

Distance factor: 1 GHz - 10 GHz 20log (4.5m / 3.0 m) = 3.53 dB

Radiated Spurious Emission
(Reference Plot for band-edge)

Test place : Ise EMC Lab. No.4 Semi Anechoic Chamber
Report No. : 11219693H
Date : May 11, 2016
Temperature / Humidity : 22 deg. C / 54 % RH
Engineer : Kazuya Yoshioka
Mode : Tx 11g 2412 MHz

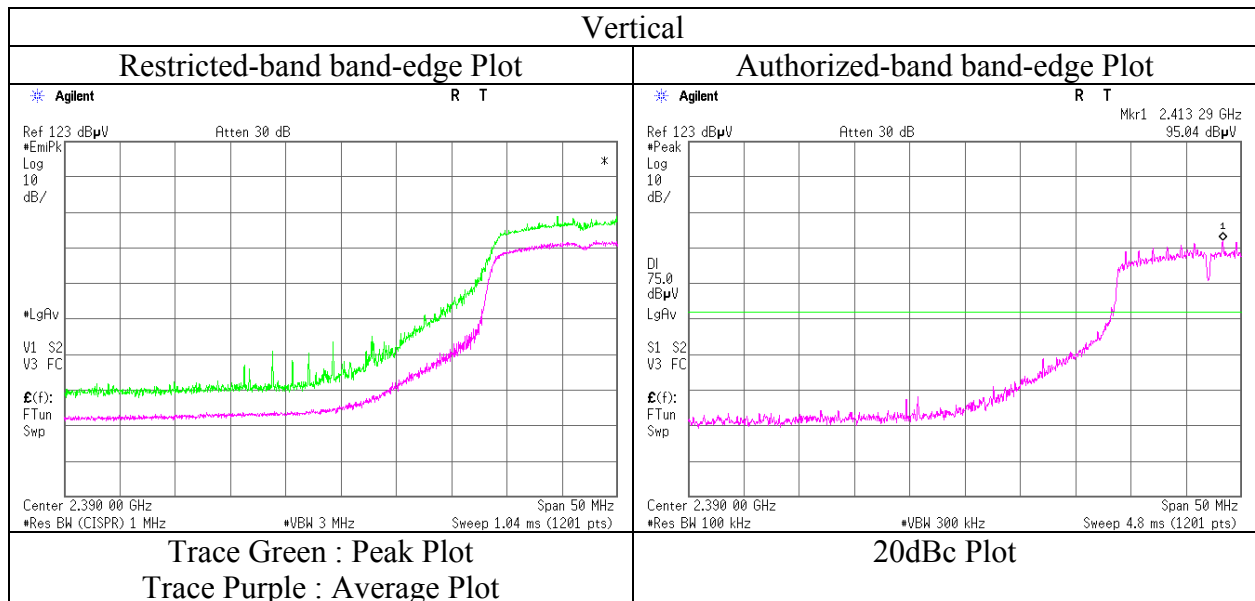
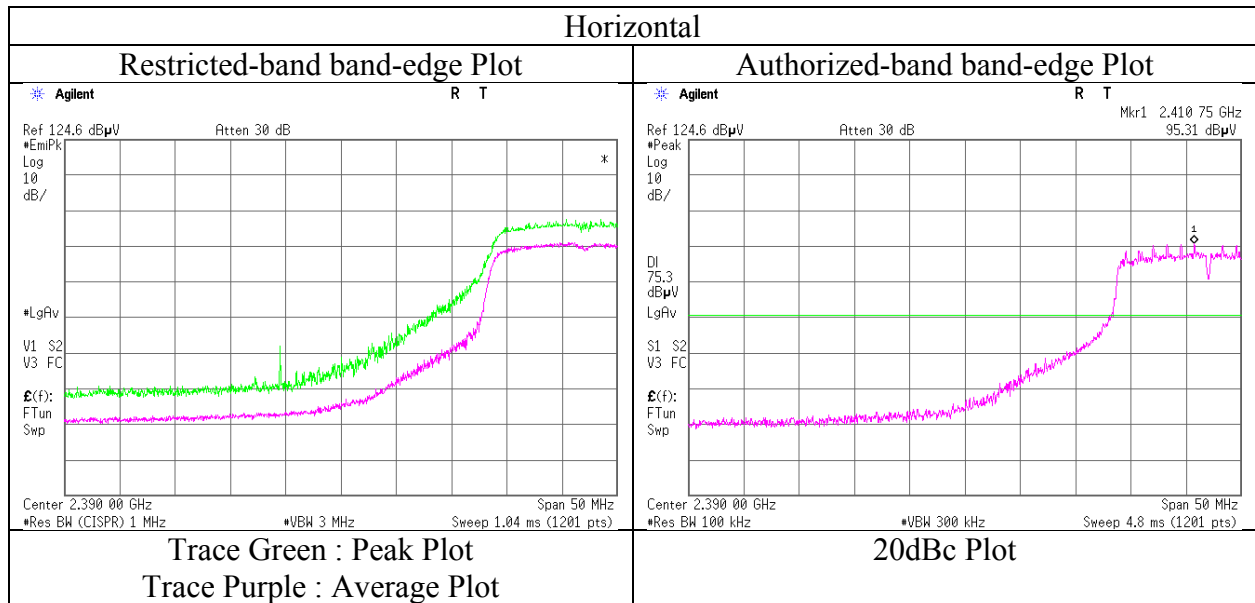

* Final result of restricted band edge was shown in tabular data.

Radiated Spurious Emission
(Plot data, Worst case)

Test place	Ise EMC Lab. No.4 Semi Anechoic Chamber	
Report No.	11219693H	
Date	May 11, 2016	May 12, 2016
Temperature / Humidity	22 deg. C / 54 % RH	22 deg. C / 54 % RH
Engineer	Kazuya Yoshioka (Above 1GHz)	Kazuya Yoshioka (Below 1GHz)
Mode	Tx 11g 2412 MHz	

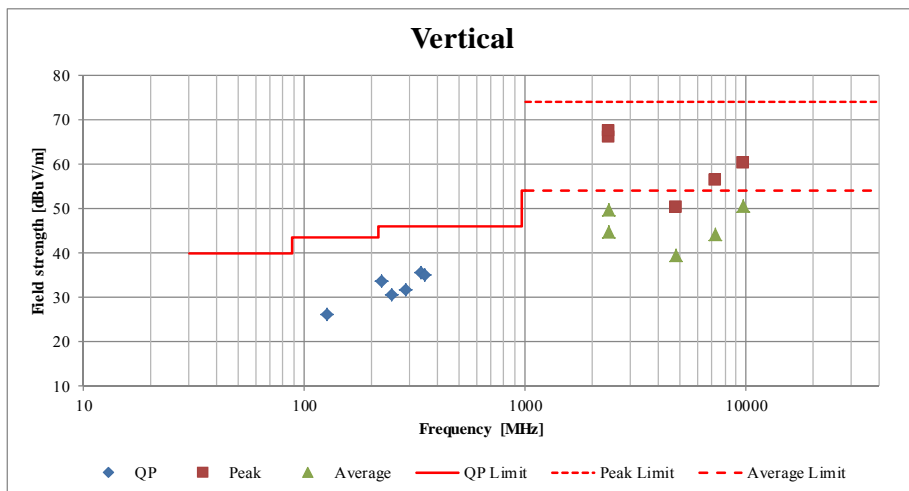
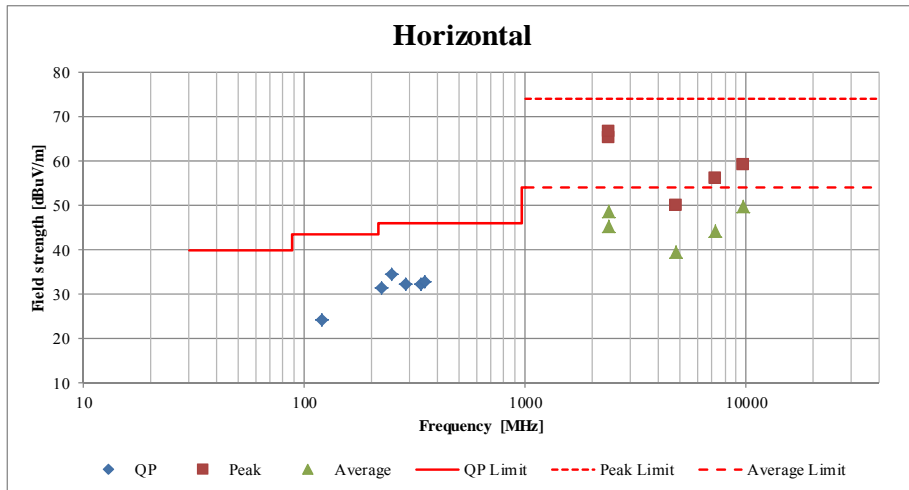

*These plots data contains sufficient number to show the trend of characteristic features for EUT.

Radiated Spurious Emission

Test place : Ise EMC Lab. No.4 Semi Anechoic Chamber
Report No. : 11219693H
Date : May 11, 2016
Temperature / Humidity : 22 deg. C / 54 % RH
Engineer : Kazuya Yoshioka
Mode : Tx 11g 2437 MHz

Polarity	Frequency [MHz]	Detector	Reading [dBuV]	Ant.Fac. [dB/m]	Loss [dB]	Gain [dB]	Result [dBuV/m]	Limit [dBuV/m]	Margin [dB]	Remark
Hori	4874.000	PK	38.8	33.1	9.2	31.3	49.8	73.9	24.1	Floor noise
Hori	7311.000	PK	40.9	36.8	10.4	32.6	55.5	73.9	18.4	Floor noise
Hori	9748.000	PK	42.4	38.2	11.2	32.7	59.1	73.9	14.8	
Hori	4874.000	AV	30.5	33.1	9.2	31.3	41.5	53.9	12.4	Floor noise
Hori	7311.000	AV	32.1	36.8	10.4	32.6	46.7	53.9	7.2	Floor noise
Hori	9748.000	AV	35.0	38.2	11.2	32.7	51.7	53.9	2.2	
Vert	4874.000	PK	39.2	33.1	9.2	31.3	50.2	73.9	23.7	Floor noise
Vert	7311.000	PK	41.0	36.8	10.4	32.6	55.6	73.9	18.3	Floor noise
Vert	9748.000	PK	42.4	38.2	11.2	32.7	59.1	73.9	14.8	
Vert	4874.000	AV	30.5	33.1	9.2	31.3	41.5	53.9	12.4	Floor noise
Vert	7311.000	AV	32.1	36.8	10.4	32.6	46.7	53.9	7.2	Floor noise
Vert	9748.000	AV	34.9	38.2	11.2	32.7	51.6	53.9	2.3	

Result = Reading + Ant Factor + Loss (Cable+Attenuator+Filter+Distance factor(above 1 GHz)) - Gain(Amplifier)

*Other frequency noises omitted in this report were not seen or had enough margin (more than 20 dB).

Distance factor: 1 GHz - 10 GHz $20\log(4.5\text{m} / 3.0\text{m}) = 3.53\text{ dB}$
10 GHz - 26.5 GHz $20\log(1.0\text{m} / 3.0\text{m}) = -9.5\text{ dB}$

Radiated Spurious Emission

Test place : Ise EMC Lab. No.4 Semi Anechoic Chamber
Report No. : 11219693H
Date : May 11, 2016
Temperature / Humidity : 22 deg. C / 54 % RH
Engineer : Kazuya Yoshioka
Mode : Tx 11g 2462 MHz

Polarity	Frequency [MHz]	Detector	Reading [dBuV]	Ant.Fac. [dB/m]	Loss [dB]	Gain [dB]	Result [dBuV/m]	Limit [dBuV/m]	Margin [dB]	Remark
Hori	2483.500	PK	58.2	28.1	6.9	32.1	61.1	73.9	12.8	
Hori	4924.000	PK	39.4	33.3	9.3	31.3	50.7	73.9	23.2	Floor noise
Hori	7386.000	PK	40.1	36.8	10.4	32.6	54.7	73.9	19.2	Floor noise
Hori	9848.000	PK	41.6	38.2	11.2	32.7	58.3	73.9	15.6	
Hori	2483.500	AV	42.2	28.1	6.9	32.1	45.1	53.9	8.8	
Hori	4924.000	AV	28.5	33.3	9.3	31.3	39.8	53.9	14.1	Floor noise
Hori	7386.000	AV	30.2	36.8	10.4	32.6	44.8	53.9	9.1	Floor noise
Hori	9848.000	AV	32.6	38.2	11.2	32.7	49.3	53.9	4.6	
Vert	2483.500	PK	59.3	28.1	6.9	32.1	62.2	73.9	11.7	
Vert	4924.000	PK	39.7	33.3	9.3	31.3	51.0	73.9	22.9	Floor noise
Vert	7386.000	PK	40.5	36.8	10.4	32.6	55.1	73.9	18.8	Floor noise
Vert	9848.000	PK	41.8	38.2	11.2	32.7	58.5	73.9	15.4	
Vert	2483.500	AV	45.6	28.1	6.9	32.1	48.5	53.9	5.4	
Vert	4924.000	AV	28.5	33.3	9.3	31.3	39.8	53.9	14.1	Floor noise
Vert	7386.000	AV	30.2	36.8	10.4	32.6	44.8	53.9	9.1	Floor noise
Vert	9848.000	AV	32.8	38.2	11.2	32.7	49.5	53.9	4.4	

Result = Reading + Ant Factor + Loss (Cable+Attenuator+Filter+Distance factor(above 1 GHz)) - Gain(Amplifier)

*Other frequency noises omitted in this report were not seen or had enough margin (more than 20 dB).

Distance factor: 1 GHz - 10 GHz $20\log(4.5\text{ m} / 3.0\text{ m}) = 3.53\text{ dB}$
10 GHz - 26.5 GHz $20\log(1.0\text{ m} / 3.0\text{ m}) = -9.5\text{ dB}$

Radiated Spurious Emission
(Reference Plot for band-edge)

Test place : Ise EMC Lab. No.4 Semi Anechoic Chamber
Report No. : 11219693H
Date : May 11, 2016
Temperature / Humidity : 22 deg. C / 54 % RH
Engineer : Kazuya Yoshioka
Mode : Tx 11g 2462 MHz

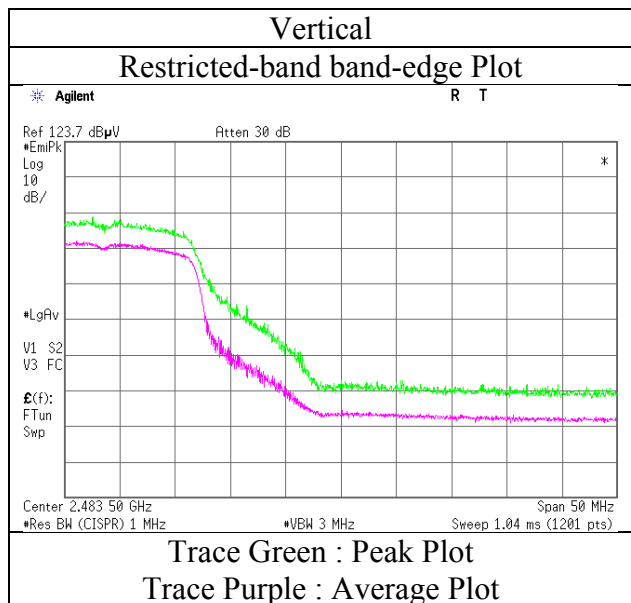
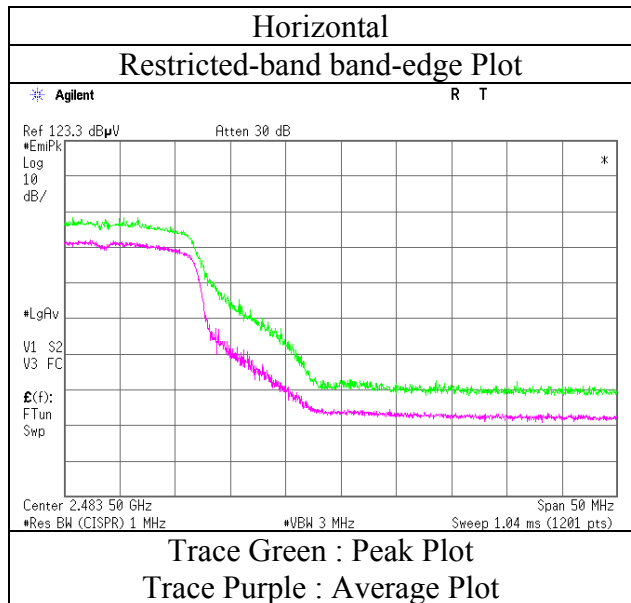

* Final result of restricted band edge was shown in tabular data.

Radiated Spurious Emission

Test place : Ise EMC Lab. No.4 Semi Anechoic Chamber
Report No. : 11219693H
Date : May 11, 2016
Temperature / Humidity : 22 deg. C / 54 % RH
Engineer : Kazuya Yoshioka

Mode : Tx 11n-20 2412 MHz

Polarity	Frequency [MHz]	Detector	Reading [dBuV]	Ant.Fac. [dB/m]	Loss [dB]	Gain [dB]	Duty Factor [dB]	Result [dBuV/m]	Limit [dBuV/m]	Margin [dB]	Remark
Hori	2388.375	PK	64.8	27.9	6.8	32.1	-	67.4	73.9	6.5	
Hori	2390.000	PK	62.5	27.9	6.8	32.1	-	65.1	73.9	8.8	
Hori	2388.375	AV	43.1	27.9	6.8	32.1	0.4	46.1	53.9	7.8	*1)
Hori	2390.000	AV	43.7	27.9	6.8	32.1	0.4	46.7	53.9	7.2	*1)
Vert	2387.725	PK	63.0	27.9	6.8	32.1	-	65.6	73.9	8.3	
Vert	2390.000	PK	63.6	27.9	6.8	32.1	-	66.2	73.9	7.7	
Vert	2387.725	AV	47.8	27.9	6.8	32.1	0.4	50.8	53.9	3.1	*1)
Vert	2390.000	AV	49.1	27.9	6.8	32.1	0.4	52.1	53.9	1.8	*1)

Result = Reading + Ant Factor + Loss (Cable+Attenuator+Filter+Distance factor(above 1 GHz)) - Gain(Amplifier) + Duty factor

*Other frequency noises omitted in this report were not seen or had enough margin (more than 20 dB).

Distance factor: 1 GHz - 10 GHz $20\log(4.5\text{ m} / 3.0\text{ m}) = 3.53\text{ dB}$
10 GHz - 26.5 GHz $20\log(1.0\text{ m} / 3.0\text{ m}) = -9.5\text{ dB}$

*1) Not Out of Band emission(Leakage Power)

20dBc Data Sheet

Polarity	Frequency [MHz]	Detector	Reading [dBuV]	Ant Factor [dB/m]	Loss [dB]	Gain [dB]	Result [dBuV/m]	Limit [dBuV/m]	Margin [dB]	Remark
Hori	2412.000	PK	94.1	28.0	6.8	32.1	96.8	-	-	Carrier
Hori	2400.000	PK	64.4	28.0	6.8	32.1	67.1	76.8	9.7	
Vert	2412.000	PK	94.2	28.0	6.8	32.1	96.9	-	-	Carrier
Vert	2400.000	PK	63.4	28.0	6.8	32.1	66.1	76.9	10.8	

Result = Reading + Ant Factor + Loss (Cable+Attenuator+Filter+Distance factor(above 1 GHz)) - Gain(Amplifier)

Distance factor: 1 GHz - 10 GHz $20\log(4.5\text{ m} / 3.0\text{ m}) = 3.53\text{ dB}$

Radiated Spurious Emission
(Reference Plot for band-edge)

Test place : Ise EMC Lab. No.4 Semi Anechoic Chamber
Report No. : 11219693H
Date : May 11, 2016
Temperature / Humidity : 22 deg. C / 54 % RH
Engineer : Kazuya Yoshioka
Mode : Tx 11n-20 2412 MHz

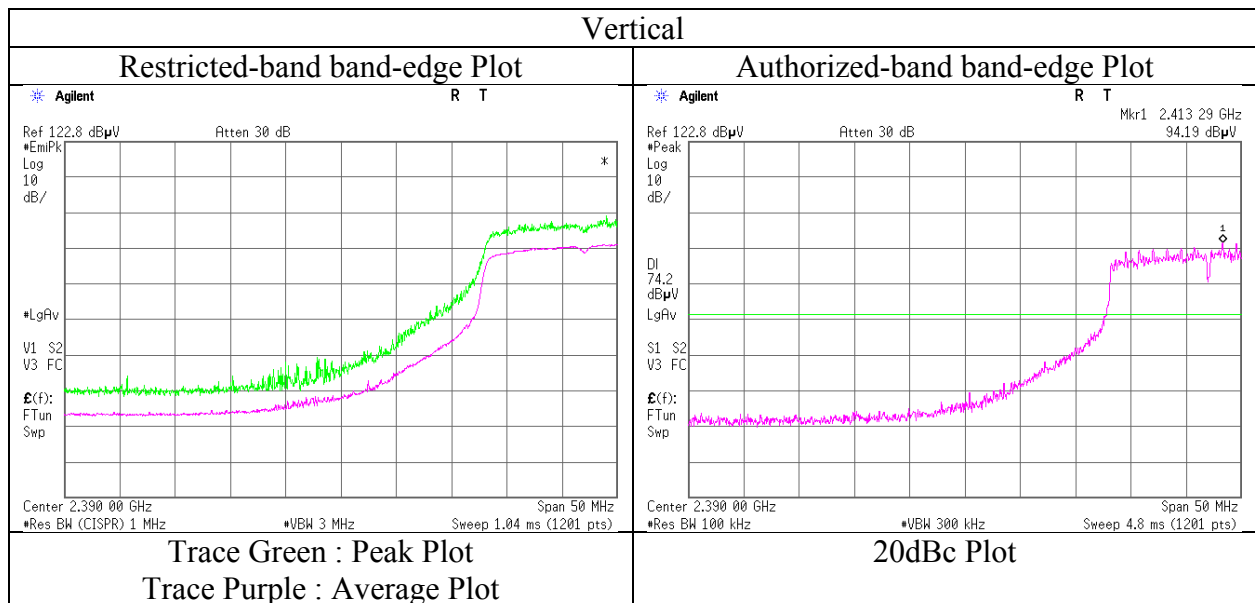
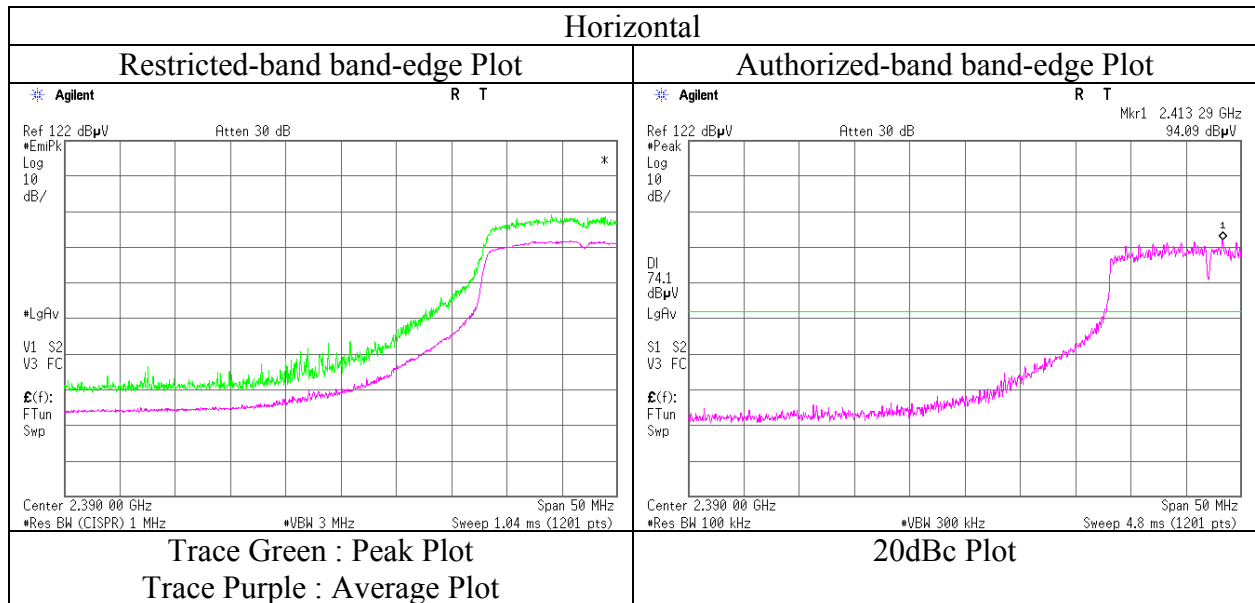

* Final result of restricted band edge was shown in tabular data.

Radiated Spurious Emission

Test place : Ise EMC Lab. No.4 Semi Anechoic Chamber
Report No. : 11219693H
Date : May 11, 2016
Temperature / Humidity : 22 deg. C / 54 % RH
Engineer : Kazuya Yoshioka

Mode : Tx 11n-20 2462 MHz

Polarity	Frequency [MHz]	Detector	Reading [dBuV]	Ant.Fac. [dB/m]	Loss [dB]	Gain [dB]	Duty Factor [dB]	Result [dBuV/m]	Limit [dBuV/m]	Margin [dB]	Remark
Hori	2483.500	PK	59.8	28.1	6.9	32.1	-	62.7	73.9	11.2	
Hori	2485.733	PK	57.1	28.1	6.9	32.1	-	60.0	73.9	13.9	
Hori	2483.500	AV	39.5	28.1	6.9	32.1	0.4	42.8	53.9	11.1	*1)
Hori	2485.733	AV	38.7	28.1	6.9	32.1	0.4	42.0	53.9	11.9	*1)
Vert	2483.500	PK	59.5	28.1	6.9	32.1	-	62.4	73.9	11.5	
Vert	2487.897	PK	58.7	28.1	6.9	32.1	-	61.6	73.9	12.3	
Vert	2483.500	AV	44.4	28.1	6.9	32.1	0.4	47.7	53.9	6.2	*1)
Vert	2487.897	AV	39.5	28.1	6.9	32.1	0.4	42.8	53.9	11.1	*1)

Result = Reading + Ant Factor + Loss (Cable+Attenuator+Filter+Distance factor(above 1 GHz)) - Gain(Amplifier) + Duty factor

*Other frequency noises omitted in this report were not seen or had enough margin (more than 20 dB).

Distance factor: 1 GHz - 10 GHz $20\log(4.5\text{m} / 3.0\text{m}) = 3.53\text{ dB}$
10 GHz - 26.5 GHz $20\log(1.0\text{m} / 3.0\text{m}) = -9.5\text{ dB}$

*1) Not Out of Band emission(Leakage Power)

Radiated Spurious Emission
(Reference Plot for band-edge)

Test place : Ise EMC Lab. No.4 Semi Anechoic Chamber
Report No. : 11219693H
Date : May 11, 2016
Temperature / Humidity : 22 deg. C / 54 % RH
Engineer : Kazuya Yoshioka
Mode : Tx 11n-20 2462 MHz

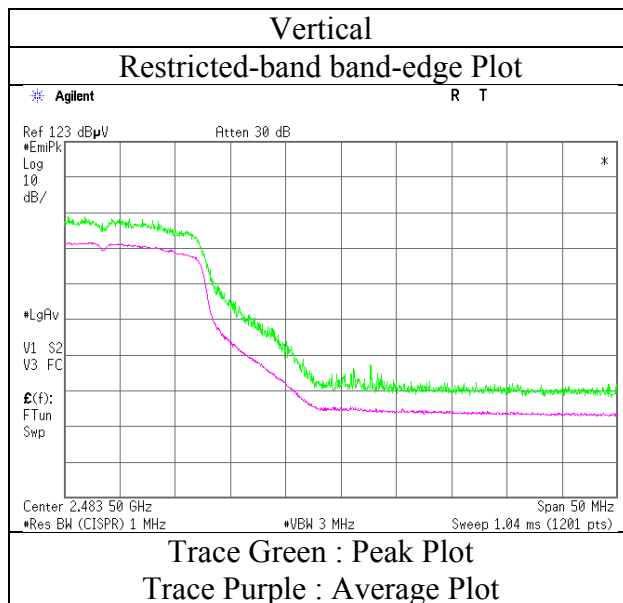
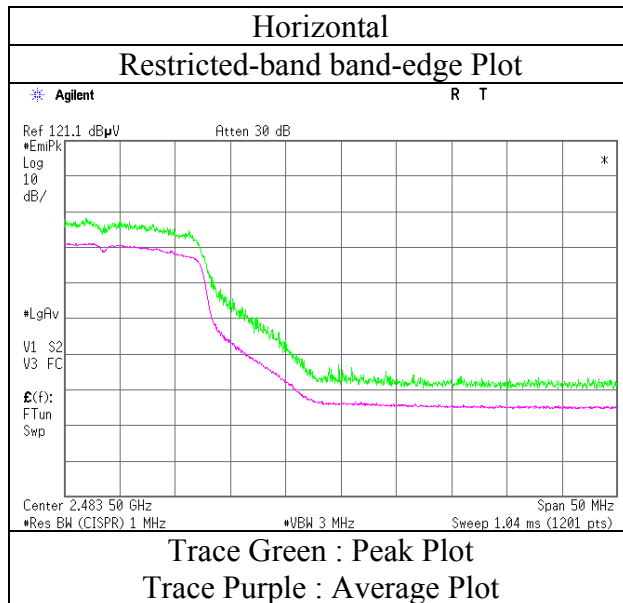

* Final result of restricted band edge was shown in tabular data.

Conducted Spurious Emission

Test place	Ise EMC Lab. No.6 Measurement Room
Report No.	11219693H
Date	May 11, 2016
Temperature / Humidity	26 deg. C / 50 % RH
Engineer	Takafumi Noguchi
Mode	Tx 11g 2412 MHz

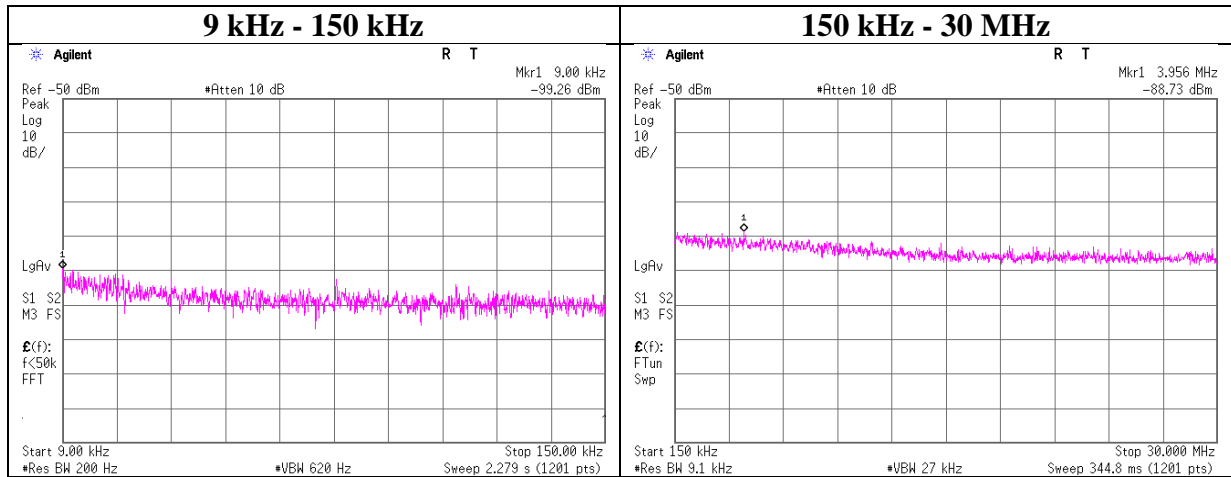

Frequency [kHz]	Reading [dBm]	Cable Loss [dB]	Attenuator Loss [dB]	Antenna Gain [dBi]	N (Number of Output)	EIRP [dBm]	Distance [m]	Ground bounce [dB]	E (field strength) [dBuV/m]	Limit [dBuV/m]	Margin [dB]	Remark
9.00	-99.3	0.70	9.8	2.0	1	-86.7	300	6.0	-25.5	48.5	74.0	
3956.00	-88.7	0.70	9.9	2.0	1	-76.1	30	6.0	5.1	29.5	24.4	

$E = \text{EIRP} - 20 \log(D) + \text{Ground bounce} + 104.8 \text{ [dBuV/m]}$

$\text{EIRP} = \text{Reading} + \text{Cable Loss} + \text{Attenuator Loss} + \text{Antenna Gain} + 10 * \log(N)$

Power Density

Test place Ise EMC Lab. No.6 Measurement Room
Report No. 11219693H
Date March 31, 2016 May 11, 2016
Temperature / Humidity 23 deg. C / 45 % RH 26 deg. C / 50 % RH
Engineer Shinichi Miyazono Takafumi Noguchi
Mode Tx

11b

Freq. [MHz]	Reading [dBm]	Cable Loss [dB]	Atten. Loss [dB]	Result [dBm]	Limit [dBm]	Margin [dB]
2412.00	-17.27	1.97	10.08	-5.22	8.00	13.22
2437.00	-16.31	1.98	10.08	-4.25	8.00	12.25
2462.00	-17.25	1.99	10.08	-5.18	8.00	13.18

11g

Freq. [MHz]	Reading [dBm]	Cable Loss [dB]	Atten. Loss [dB]	Result [dBm]	Limit [dBm]	Margin [dB]
2412.00	-21.90	1.64	9.54	-10.72	8.00	18.72
2437.00	-21.38	1.65	9.54	-10.19	8.00	18.19
2462.00	-22.33	1.65	9.54	-11.14	8.00	19.14

Sample Calculation:

Result = Reading + Cable Loss (including the cable(s) customer supplied) + Attenuator

Power Density

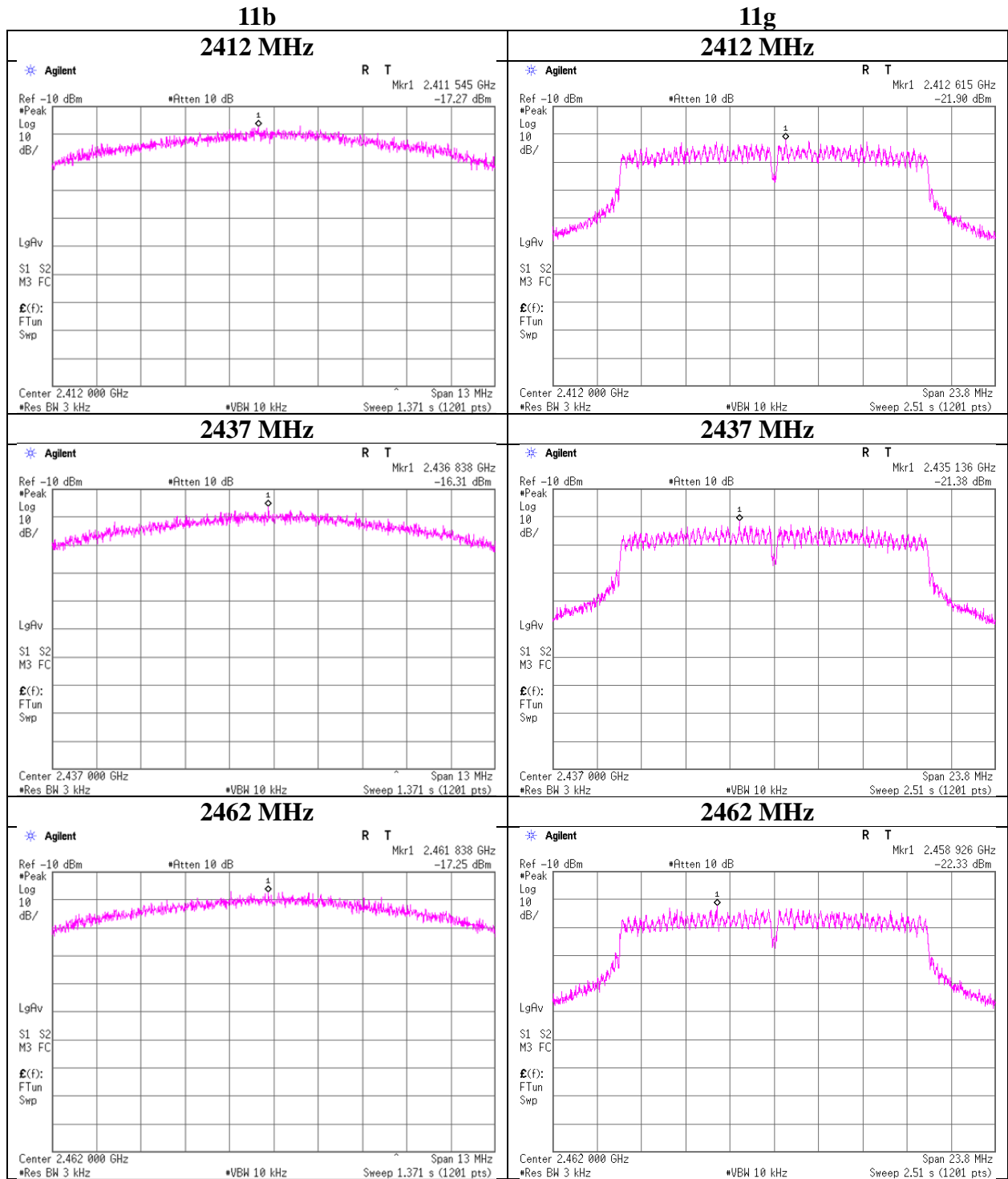

UL Japan, Inc.

Ise EMC Lab.

4383-326 Asama-cho, Ise-shi, Mie-ken 516-0021 JAPAN

Telephone : +81 596 24 8999

Facsimile : +81 596 24 8124

Power Density

Test place Ise EMC Lab. No.6 Measurement Room
Report No. 11219693H
Date May 11, 2016
Temperature / Humidity 26 deg. C / 50 % RH
Engineer Takafumi Noguchi
Mode Tx

11n-20

Freq. [MHz]	Reading [dBm]	Cable Loss [dB]	Atten. Loss [dB]	Result		Limit [dBm]	Margin [dB]
				[dBm]	[mW]		
2412.00	-23.83	1.64	9.54	-12.65	0.05	8.00	20.65
2437.00	-23.79	1.65	9.54	-12.60	0.05	8.00	20.60
2462.00	-23.34	1.65	9.54	-12.15	0.06	8.00	20.15

Sample Calculation:

Result = Reading + Cable Loss (including the cable(s) customer supplied) + Attenuator Loss

Power Density

11n-20

2412 MHz

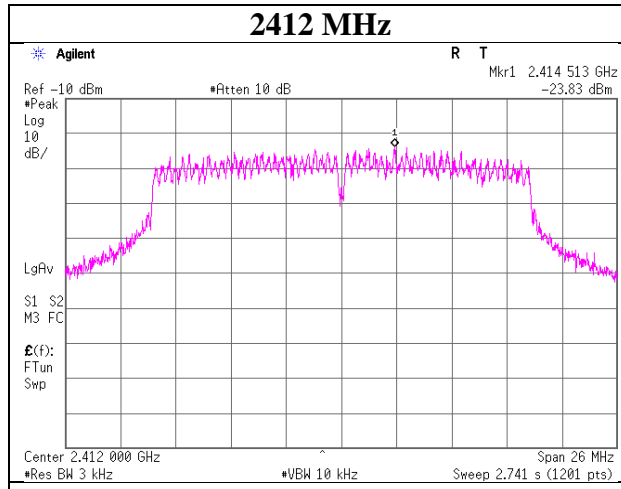

2437 MHz

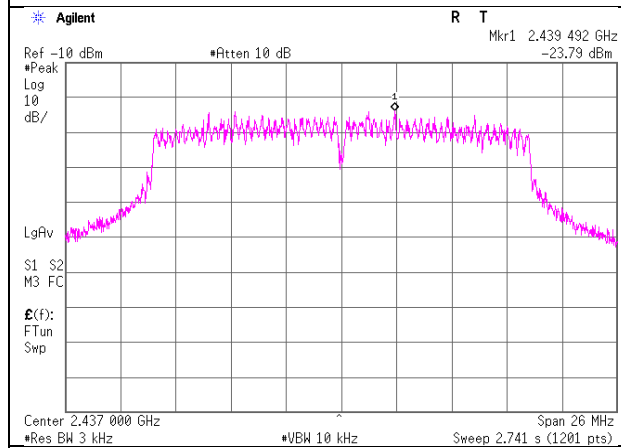

2462 MHz

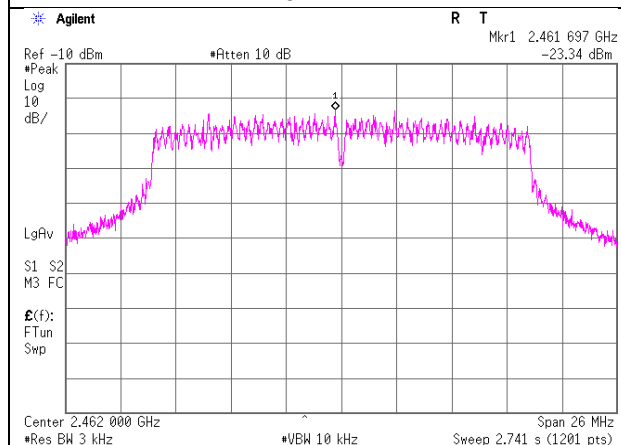

UL Japan, Inc.

Ise EMC Lab.

4383-326 Asama-cho, Ise-shi, Mie-ken 516-0021 JAPAN

Telephone : +81 596 24 8999

Facsimile : +81 596 24 8124

99% Occupied Bandwidth

Test place Report No. Date Temperature / Humidity Engineer Mode	Ise EMC Lab. No.6 Measurement Room 11219693H March 31, 2016 23 deg. C / 45 % RH Shinichi Miyazono Tx
	May 11, 2016 26 deg. C / 50 % RH Takafumi Noguchi

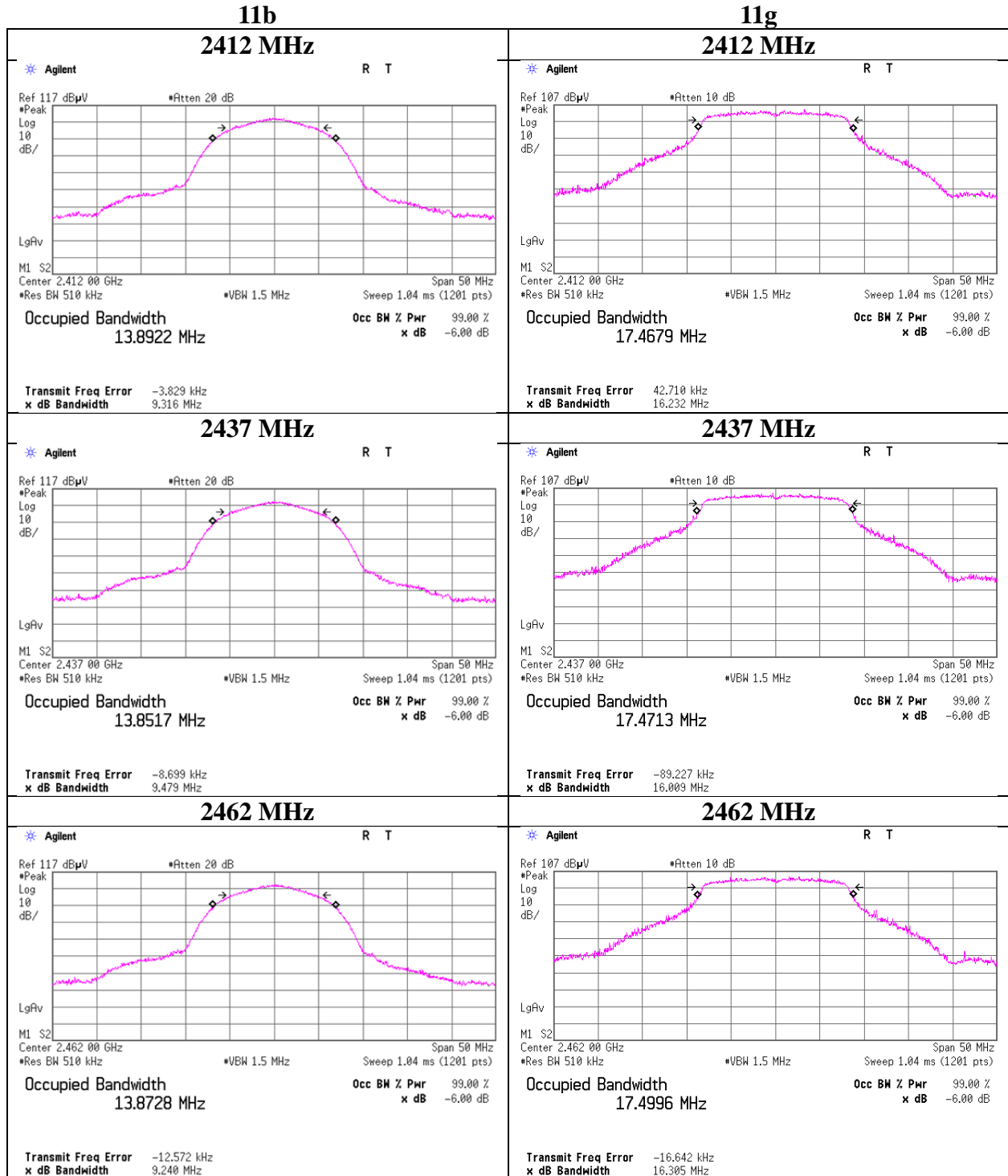

UL Japan, Inc.

Ise EMC Lab.

4383-326 Asama-cho, Ise-shi, Mie-ken 516-0021 JAPAN

Telephone : +81 596 24 8999

Facsimile : +81 596 24 8124

99% Occupied Bandwidth

Test place	Ise EMC Lab. No.6 Measurement Room
Report No.	11219693H
Date	May 11, 2016
Temperature / Humidity	26 deg. C / 50 % RH
Engineer	Takafumi Noguchi
Mode	Tx

11n-20

2412 MHz

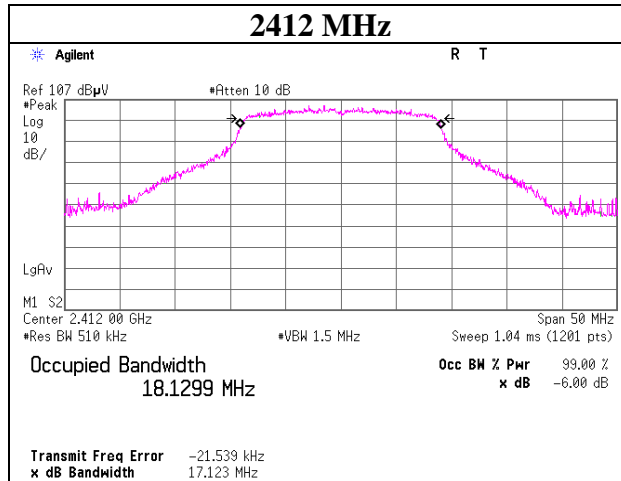

2437 MHz

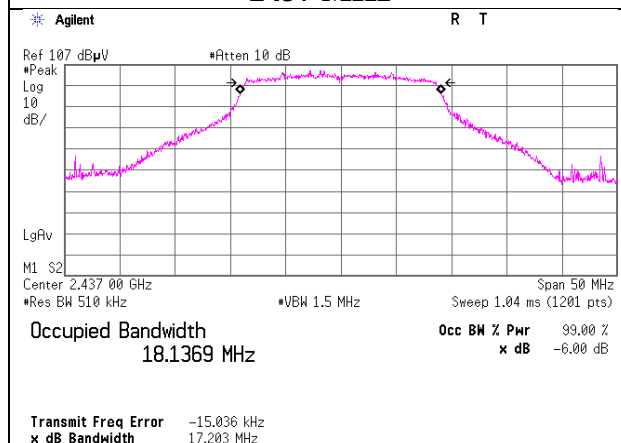

2462 MHz

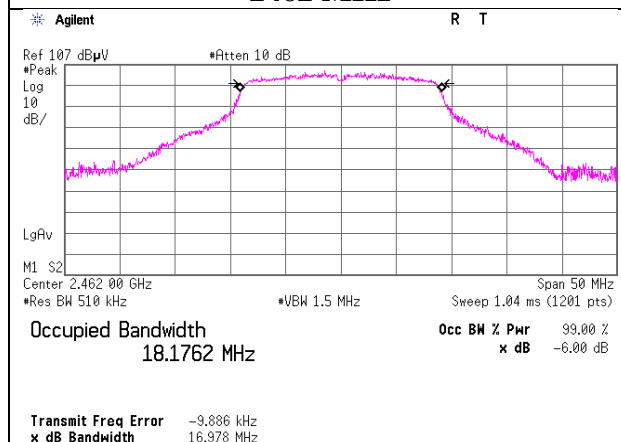

UL Japan, Inc.

Ise EMC Lab.

4383-326 Asama-cho, Ise-shi, Mie-ken 516-0021 JAPAN

Telephone : +81 596 24 8999

Facsimile : +81 596 24 8124

APPENDIX 2: Test instruments

Test equipment (1/2)

Control No.	Instrument	Manufacturer	Model No	Serial No	Test Item	Calibration Date * Interval(month)
MPM-09	Power Meter	Anritsu	ML2495A	6K00003348	AT	2015/10/19 * 12
MPSE-12	Power sensor	Anritsu	MA2411B	011598	AT	2015/10/19 * 12
MCC-138	Microwave cable	HUBER+SUHNER	SUCOFLEX 102	37953/2	AT	2015/10/08 * 12
MAT-20	Attenuator(10dB)(above 1GHz)	HIROSE ELECTRIC CO.,LTD.	AT-110	-	AT	2016/01/08 * 12
MCC-38	Coaxial Cable	UL Japan	-	-	AT	2015/12/07 * 12
MAEC-03	Semi Anechoic Chamber(NSA)	TDK	Semi Anechoic Chamber 3m	DA-10005	RE	2015/10/01 * 12
MOS-13	Thermo-Hygrometer	Custom	CTH-180	1301	RE	2016/01/21 * 12
MJM-16	Measure	KOMELON	KMC-36	-	RE	-
MSA-15	Spectrum Analyzer	Agilent	E4440A	MY46187105	RE	2015/11/11 * 12
MHA-20	Horn Antenna 1-18GHz	Schwarzbeck	BBHA9120D	258	RE	2015/05/18 * 12
MCC-167	Microwave Cable	Junkosha	MWX221	1404S374(1m) / 1405S074(5m)	RE	2015/05/21 * 12
MPA-11	MicroWave System Amplifier	Agilent	83017A	MY39500779	RE	2016/03/24 * 12
MMM-08	DIGITAL HiTESTER	Hioki	3805	051201197	RE	2016/01/13 * 12
MHF-25	High Pass Filter 3.5-18.0GHz	UL Japan	HPF SELECTOR	001	RE	2015/09/16 * 12
MHA-16	Horn Antenna 15-40GHz	Schwarzbeck	BBHA9170	BBHA9170306	RE	2015/05/19 * 12
MMM-12	DIGITAL HiTESTER	Hioki	3805	060500120	AT	2016/02/23 * 12
MOS-14	Thermo-Hygrometer	Custom	CTH-201	1401	AT	2016/01/21 * 12
MAT-10	Attenuator(10dB)	Weinschel Corp	2	BL1173	AT	2015/11/10 * 12
MAT-90	Attenuator	Weinschel Associates	WA56-10	56100306	AT	2015/06/01 * 12
MCC-144	Microwave Cable	Junkosha	MWX221	1207S407	AT	2015/08/06 * 12
MSA-10	Spectrum Analyzer	Agilent	E4448A	MY46180655	AT	2016/02/24 * 12
MPM-12	Power Meter	Anritsu	ML2495A	0825002	AT	2015/06/09 * 12
MPSE-17	Power sensor	Anritsu	MA2411B	0738285	AT	2015/06/09 * 12
MAEC-04	Semi Anechoic Chamber(NSA)	TDK	Semi Anechoic Chamber 3m	DA-10005	RE/CE	2015/10/02 * 12
MOS-15	Thermo-Hygrometer	Custom	CTH-180	1501	RE/CE	2016/01/21 * 12
MJM-26	Measure	KOMELON	KMC-36	-	RE/CE	-
COTS-MEMI	EMI measurement program	TSJ	TEPTO-DV	-	RE/CE	-
MRENT-126	Spectrum Analyzer	KEYSIGHT	E4440A	MY46185516	RE	2015/07/31 * 12
MHA-21	Horn Antenna 1-18GHz	Schwarzbeck	BBHA9120D	9120D-557	RE	2015/08/10 * 12
MCC-141	Microwave Cable	Junkosha	MWX221	1305S002R(1m) / 1405S146(5m)	RE	2015/06/22 * 12
MPA-12	MicroWave System Amplifier	Agilent	83017A	00650	RE	2015/10/01 * 12
MHA-17	Horn Antenna 15-40GHz	Schwarzbeck	BBHA9170	BBHA9170307	RE	2015/06/06 * 12
MMM-10	DIGITAL HiTESTER	Hioki	3805	051201148	RE/CE	2016/01/18 * 12
MHF-26	High Pass Filter 3.5-18.0GHz	UL Japan	HPF SELECTOR	002	RE	2015/09/17 * 12
MTR-10	EMI Test Receiver	Rohde & Schwarz	ESR26	101408	RE/CE	2016/01/29 * 12

UL Japan, Inc.

Ise EMC Lab.

4383-326 Asama-cho, Ise-shi, Mie-ken 516-0021 JAPAN

Telephone : +81 596 24 8999

Facsimile : +81 596 24 8124

Test equipment (2/2)

Control No.	Instrument	Manufacturer	Model No	Serial No	Test Item	Calibration Date * Interval(month)
MBA-05	Biconical Antenna	Schwarzbeck	BBA9106	1302	RE	2015/11/02 * 12
MLA-23	Logperiodic Antenna(200-1000MHz)	Schwarzbeck	VUSLP9111B	911B-192	RE	2016/01/30 * 12
MCC-50	Coaxial Cable	UL Japan	-	-	RE	2015/06/19 * 12
MAT-68	Attenuator	Anritsu	MP721B	6200961025	RE	2015/11/12 * 12
MPA-14	Pre Amplifier	SONOMA INSTRUMENT	310	260833	RE	2016/03/18 * 12
MLS-23	LISN(AMN)	Schwarzbeck	NSLK8127	8127-729	CE(EUT)	2015/07/10 * 12
MLS-24	LISN(AMN)	Schwarzbeck	NSLK8127	8127-730	CE(AE)	2015/07/10 * 12
MTA-53	Terminator	TME	CT-01BP	-	CE	2015/12/01 * 12
MAT-67	Attenuator	JFW Industries, Inc.	50FP-013H2 N	-	CE	2016/01/14 * 12
MCC-113	Coaxial cable	Fujikura/Suhner/TSJ	5D-2W(10m)/SFM141(5m)/421-010(1m)/sucoform141-PE(1m)/RFM-E121(Switcher)	-/04178	CE	2015/07/02 * 12

The expiration date of the calibration is the end of the expired month.

All equipment is calibrated with valid calibrations. Each measurement data is traceable to the national or international standards.

As for some calibrations performed after the tested dates, those test equipment have been controlled by means of an unbroken chains of calibrations.

**Test Item: CE: Conducted Emission test
RE: Radiated Emission test
AT: Antenna Terminal Conducted test**

UL Japan, Inc.

Ise EMC Lab.

4383-326 Asama-cho, Ise-shi, Mie-ken 516-0021 JAPAN

Telephone : +81 596 24 8999

Facsimile : +81 596 24 8124