

## Partial FCC Test Report

**Report No.:** RF160316C18-3

**FCC ID:** VPYLB1EN

**Test Model:** LBEE5ZZ1EN

**Received Date:** Mar. 16, 2016

**Test Date:** Apr. 02, 2016 ~ Apr. 12, 2016

**Issued Date:** Apr. 26, 2016

**Applicant:** MURATA MANUFACTURING CO., LTD.

**Address:** 10-1, Higashikotari 1-chome, Nagaokakyo-shi, Kyoto 617-8555 Japan

**Issued By:** Bureau Veritas Consumer Products Services (H.K.) Ltd., Taoyuan Branch

**Lab Address:** No. 47-2, 14th Ling, Chia Pau Vil., Lin Kou Dist., New Taipei City, Taiwan  
( R.O.C )

**Test Location:** No. 19, Hwa Ya 2nd Rd, Wen Hwa Tsuen, Kwei Shan Hsiang, Taoyuan  
Hsien 333, Taiwan, R.O.C.



This report is for your exclusive use. Any copying or replication of this report to or for any other person or entity, or use of our name or trademark, is permitted only with our prior written permission. This report sets forth our findings solely with respect to the test samples identified herein. The results set forth in this report are not indicative or representative of the quality or characteristics of the lot from which a test sample was taken or any similar or identical product unless specifically and expressly noted. Our report includes all of the tests requested by you and the results thereof based upon the information that you provided to us. You have 60 days from date of issuance of this report to notify us of any material error or omission caused by our negligence, provided, however, that such notice shall be in writing and shall specifically address the issue you wish to raise. A failure to raise such issue within the prescribed time shall constitute your unqualified acceptance of the completeness of this report, the tests conducted and the correctness of the report contents. Unless specific mention, the uncertainty of measurement has been explicitly taken into account to declare the compliance or non-compliance to the specification. The report must not be used by the client to claim product certification, approval, or endorsement by TAF or any government agencies.

## Table of Contents

<b>Release Control Record .....</b>	<b>3</b>
<b>1 Certificate of Conformity .....</b>	<b>4</b>
<b>2 Summary of Test Results.....</b>	<b>5</b>
2.1 Measurement Uncertainty.....	5
2.2 Modification Record .....	5
<b>3 General Information .....</b>	<b>6</b>
3.1 General Description of EUT .....	6
3.2 Description of Test Modes.....	8
3.2.1 Test Mode Applicability and Tested Channel Detail.....	10
3.3 Description of Support Units .....	12
3.3.1 Configuration of System under Test .....	12
3.4 General Description of Applied Standards.....	12
<b>4 Test Types and Results .....</b>	<b>13</b>
4.1 Radiated Emission and Bandedge Measurement .....	13
4.1.1 Limits of Radiated Emission and Bandedge Measurement .....	13
4.1.2 Limits of Unwanted Emission Out of the Restricted Bands.....	13
4.1.3 Test Instruments .....	14
4.1.4 Test Procedures.....	15
4.1.5 Deviation from Test Standard .....	15
4.1.6 Test Set Up .....	16
4.1.7 EUT Operating Conditions.....	16
4.1.8 Test Results .....	17
4.2 Conducted Emission Measurement.....	153
4.2.1 Limits of Conducted Emission Measurement .....	153
4.2.2 Test Instruments .....	153
4.2.3 Test Procedures.....	154
4.2.4 Deviation from Test Standard .....	154
4.2.5 Test Setup.....	154
4.2.6 EUT Operating Conditions.....	154
4.2.7 Test Results .....	155
<b>5 Pictures of Test Arrangements.....</b>	<b>159</b>
<b>Appendix – Information on the Testing Laboratories .....</b>	<b>160</b>



### Release Control Record

Issue No.	Description	Date Issued
RF160316C18-3	Original Release	Apr. 26, 2016

## 1 Certificate of Conformity

**Product:** Communication Module

**Brand:** Murata

**Test Model:** LBEE5ZZ1EN

**Sample Status:** Identical Prototype

**Applicant:** MURATA MANUFACTURING CO., LTD.

**Test Date:** Apr. 02, 2016 ~ Apr. 12, 2016

**Standards:** 47 CFR FCC Part 15, Subpart E (Section 15.407)  
ANSI C63.10:2013

The above equipment has been tested by **Bureau Veritas Consumer Products Services (H.K.) Ltd., Taoyuan Branch**, and found compliance with the requirement of the above standards. The test record, data evaluation & Equipment Under Test (EUT) configurations represented herein are true and accurate accounts of the measurements of the sample's EMC characteristics under the conditions specified in this report.

**Prepared by :** Gina Liu , **Date:** Apr. 26, 2016  
Gina Liu / Specialist

**Approved by :** David Huang , **Date:** Apr. 26, 2016  
David Huang / Project Engineer

## 2 Summary of Test Results

47 CFR FCC Part 15, Subpart E (Section 15.407)			
FCC Clause	Test Item	Result	Remarks
15.407(b)(6)	AC Power Conducted Emissions	Pass	Meet the requirement of limit. Minimum passing margin is -15.22 dB at 2.502 MHz.
15.407(b) (1/2/3/4/6)	Radiated Emissions & Band Edge Measurement	Pass	Meet the requirement of limit. Minimum passing margin is -4.62 dB at 5725 MHz.
15.407(a)(1/2 /3)	Max Average Transmit Power	N/A	Refer to Note
15.407(a)(1/2 /3)	Peak Power Spectral Density	N/A	Refer to Note
15.407(e)	6 dB Bandwidth	N/A	Refer to Note
15.407(g)	Frequency Stability	N/A	Refer to Note
15.203	Antenna Requirement	N/A	Refer to Note

Note: Only test item of Conducted and Radiated Emissions were performed for this report. Other testing data is referring to UL Japan, Inc. module report (Test Report No.: 10689818H-C, Issue Date: Jun. 17, 2015).

### 2.1 Measurement Uncertainty

Where relevant, the following measurement uncertainty levels have been estimated for tests performed on the EUT as specified in CISPR 16-4-2:

Measurement	Frequency	Expanded Uncertainty (k=2) (±)
Radiated Emissions up to 1 GHz	30 MHz ~ 200 MHz	2.93 dB
	200 MHz ~1000 MHz	2.95 dB
Radiated Emissions above 1 GHz	1 GHz ~ 18 GHz	2.26 dB
	18 GHz ~ 40 GHz	1.94 dB

### 2.2 Modification Record

There were no modifications required for compliance.

### 3 General Information

#### 3.1 General Description of EUT

<b>Product</b>	Communication Module
<b>Brand</b>	Murata
<b>Test Model</b>	LBEE5ZZ1EN
<b>Status of EUT</b>	Identical Prototype
<b>Power Supply Rating</b>	19.5 Vdc (adapter)
<b>Modulation Type</b>	256QAM, 64QAM, 16QAM, QPSK, BPSK
<b>Modulation Technology</b>	OFDM
<b>Transfer Rate</b>	802.11a: 54.0/ 48.0/ 36.0/ 24.0/ 18.0/ 12.0/ 9.0/ 6.0 Mbps 802.11n: up to MCS7 802.11ac: up to V9
<b>Operating Frequency</b>	5180 ~ 5240 MHz, 5260 ~ 5320 MHz, 5500 ~ 5700 MHz, 5745 ~ 5825 MHz
<b>Number of Channel</b>	5180 ~ 5240 MHz: 4 for 802.11a, 802.11n (HT20) 2 for 802.11ac (VHT40) 1 for 802.11ac (VHT80) 5260 ~ 5320 MHz: 4 for 802.11a, 802.11n (HT20) 2 for 802.11ac (VHT40) 1 for 802.11ac (VHT80) 5500 ~ 5700 MHz: 11 for 802.11a, 802.11n (HT20) 5 for 802.11ac (VHT40) 2 for 802.11ac (VHT80) 5745 ~ 5825 MHz: 5 for 802.11a, 802.11n (HT20) 2 for 802.11ac (VHT40) 1 for 802.11ac (VHT80)
<b>Antenna Type</b>	Refer to Note as below
<b>Antenna Connector</b>	N/A
<b>Accessory Device</b>	N/A
<b>Data Cable Supplied</b>	N/A

**Note:**

- The EUT incorporates a MIMO function. Physically, the EUT provides two completed transmitters and two receivers.

Modulation Mode	Tx Function
802.11a	1TX
802.11n (HT20)	1TX, 2TX
802.11ac (VHT40)	1TX, 2TX
802.11ac (VHT80)	1TX, 2TX

\* The modulation and bandwidth are similar for 802.11n mode for HT20 and 802.11ac mode for VHT40 / VHT80, therefore investigated worst case to representative mode in test report. (Final test mode refer section 3.2.1)

2. The antenna information is listed as below.

Antenna Type	Brand Name	Parts Number	Antenna Gain (dBi)			
			5180-5240 MHz	5260-5320 MHz	5500-5700 MHz	5745-5825 MHz
Dipole	Laird	WLAN Main Antenna: PDV24515-DE1	Main: 4.0	Main: 4.0	Main: 4.0	Main: 3.9
		WLAN Aux Antenna: PDV24515-DE1	Aux: 4.0	Aux: 4.0	Aux: 4.0	Aux: 3.9
Monopole	Taoglas Antenna Solution Ltd.	WLAN Main Antenna: MA761.B.BICG.014	Main: 4.11	Main: 4.11	Main: 4.11	Main: 4.11
		WLAN Aux Antenna: MA761.B.BICG.014	Aux: 4.51	Aux: 4.51	Aux: 4.51	Aux: 4.51

3. The EUT is authorized for use in specific End-product. Please refer to below table for more details.

Item	Brand	Model
Industrial Computer	Dell	N01PC

4. The above EUT information is declared by manufacturer and for more detailed features description, please refer to the manufacturer's specifications or user's manual.

### 3.2 Description of Test Modes

#### FOR 5180 ~ 5240 MHz

4 channels are provided for 802.11a, 802.11n (HT20):

Channel	Frequency (MHz)	Channel	Frequency (MHz)
36	5180	44	5220
40	5200	48	5240

2 channels are provided for 802.11 ac (VHT40):

Channel	Frequency (MHz)	Channel	Frequency (MHz)
38	5190	46	5230

1 channel is provided for 802.11ac (VHT80):

Channel	Frequency (MHz)
42	5210

#### FOR 5260 ~ 5320 MHz

4 channels are provided for 802.11a, 802.11n (HT20):

Channel	Frequency (MHz)	Channel	Frequency (MHz)
52	5260	60	5300
56	5280	64	5320

2 channels are provided for 802.11 ac (VHT40):

Channel	Frequency (MHz)	Channel	Frequency (MHz)
54	5270	62	5310

1 channel is provided for 802.11ac (VHT80):

Channel	Frequency (MHz)
58	5290



**FOR 5500 ~ 5700 MHz**

11 channels are provided for 802.11a, 802.11n (HT20):

Channel	Frequency (MHz)	Channel	Frequency (MHz)
100	5500	124	5620
104	5520	128	5640
108	5540	132	5660
112	5560	136	5680
116	5580	140	5700
120	5600		

5 channels are provided for 802.11 ac (VHT40):

Channel	Frequency (MHz)	Channel	Frequency (MHz)
102	5510	126	5630
110	5550	134	5670
118	5590		

2 channels are provided for 802.11 ac (VHT80):

Channel	Frequency (MHz)	Channel	Frequency (MHz)
106	5530	122	5610

**FOR 5745 ~ 5825 MHz:**

5 channels are provided for 802.11a, 802.11n (HT20):

Channel	Frequency (MHz)	Channel	Frequency (MHz)
149	5745	161	5805
153	5765	165	5825
157	5785		

2 channels are provided for 802.11 ac (VHT40):

Channel	Frequency (MHz)	Channel	Frequency (MHz)
151	5755	159	5795

1 channel is provided for 802.11 ac (VHT80):

Channel	Frequency (MHz)
155	5775

### 3.2.1 Test Mode Applicability and Tested Channel Detail

EUT Configure Mode	Applicable To				Description
	RE $\geq$ 1G	RE $<$ 1G	PLC	APCM	
A	√	√	√	-	1TX (Dipol Antenna)
B	√	-	-	-	2TX (Dipol Antenna)
C	√	√	√	-	1TX (Momopole Antenna)
D	√	-	-	-	2TX (Momopole Antenna)

Where **RE $\geq$ 1G**: Radiated Emission above 1 GHz      **RE $<$ 1G**: Radiated Emission below 1 GHz  
**PLC**: Power Line Conducted Emission      **APCM**: Antenna Port Conducted Measurement

**NOTE:**

- The EUT had been pre-tested on the positioned of each 3 axis. The worst case was found when positioned on **Z-plane** for Mode A, B and **X-plane** for Mode C, D.
- "-" means no effect.

#### **Radiated Emission Test (Above 1 GHz):**

- Pre-Scan has been conducted to determine the worst-case mode from all possible combinations between available modulations, data rates and antenna ports (if EUT with antenna diversity architecture).
- Following channel(s) was (were) selected for the final test as listed below.

EUT Configure Mode	Frequency Band (MHz)	Mode	Available Channel	Tested Channel	Modulation Technology	Modulation Type	Data Rate (Mbps)
A, C	5180-5240	802.11a	36 to 48	36, 44, 48	OFDM	BPSK	6.0
A, B, C, D		802.11n (HT20)	36 to 48	36, 44, 48	OFDM	BPSK	MCS0
		802.11ac (VHT40)	38 to 46	38, 46	OFDM	BPSK	MCS0
		802.11ac (VHT80)	42	42	OFDM	BPSK	V0
A, C	5260-5320	802.11a	52 to 64	52, 60, 64	OFDM	BPSK	6.0
A, B, C, D		802.11n (HT20)	52 to 64	52, 60, 64	OFDM	BPSK	MCS0
		802.11ac (VHT40)	54 to 62	54, 62	OFDM	BPSK	MCS0
		802.11ac (VHT80)	58	58	OFDM	BPSK	V0
A, C	5500-5700	802.11a	100 to 140	100, 116, 140	OFDM	BPSK	6.0
A, B, C, D		802.11n (HT20)	100 to 140	100, 116, 140	OFDM	BPSK	MCS0
		802.11ac (VHT40)	102 to 134	102, 110, 134	OFDM	BPSK	MCS0
		802.11ac (VHT80)	106 to 122	106, 122	OFDM	BPSK	V0
A, C	5745-5825	802.11a	149 to 165	149, 157, 165	OFDM	BPSK	6.0
A, B, C, D		802.11n (HT20)	149 to 165	149, 157, 165	OFDM	BPSK	MCS0
		802.11ac (VHT40)	151 to 159	151, 159	OFDM	BPSK	MCS0
		802.11ac (VHT80)	155	155	OFDM	BPSK	V0

#### **Radiated Emission Test (Below 1 GHz):**

- Pre-Scan has been conducted to determine the worst-case mode from all possible combinations between available modulations, data rates and antenna ports (if EUT with antenna diversity architecture).
- Following channel(s) was (were) selected for the final test as listed below.

EUT Configure Mode	Frequency Band (MHz)	Mode	Available Channel	Tested Channel	Modulation Technology	Modulation Type	Data Rate (Mbps)
A, C	5180-5240	802.11a	36 to 48	36	OFDM	BPSK	6.0
	5260-5320	802.11a	52 to 64	64	OFDM	BPSK	6.0
	5500-5700	802.11ac (VHT80)	106 to 122	106	OFDM	BPSK	V0
	5745-5825	802.11a	149 to 165	165	OFDM	BPSK	6.0

**Power Line Conducted Emission Test:**

- Pre-Scan has been conducted to determine the worst-case mode from all possible combinations between available modulations, data rates and antenna ports (if EUT with antenna diversity architecture).
- Following channel(s) was (were) selected for the final test as listed below.

EUT Configure Mode	Frequency Band (MHz)	Mode	Available Channel	Tested Channel	Modulation Technology	Modulation Type	Data Rate (Mbps)
A, C	5180-5320	802.11a	36 to 64	36	OFDM	BPSK	6.0

**Test Condition:**

Applicable To	Environmental Conditions	Input Power	Tested by
RE $\geq$ 1G	25 deg. C, 65 % RH	120 Vac, 60 Hz	Toby Tian, Anson Lin, Gavin Wu
RE $<$ 1G	25 deg. C, 65 % RH	120 Vac, 60 Hz	Toby Tian
PLC	25 deg. C, 65 % RH	120 Vac, 60 Hz	Toby Tian

### 3.3 Description of Support Units

The EUT has been tested as an independent unit together with other necessary accessories or support units.

#### 3.3.1 Configuration of System under Test

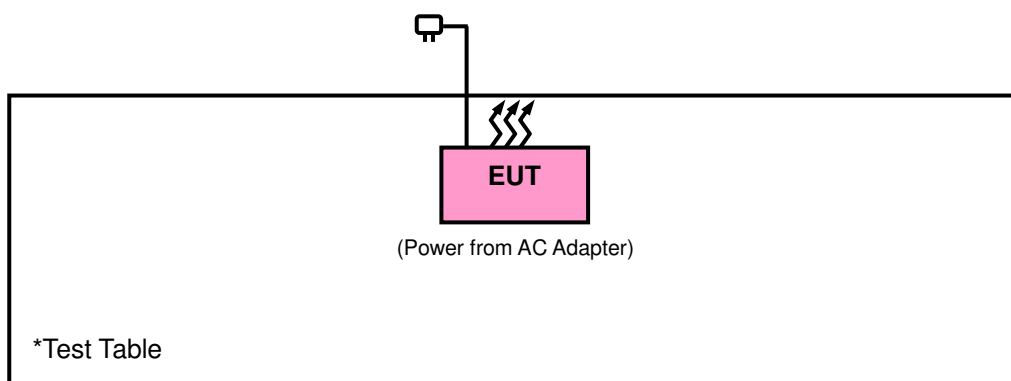

### 3.4 General Description of Applied Standards

The EUT is a RF Product. According to the specifications of the manufacturer, it must comply with the requirements of the following standards:

**FCC Part 15, Subpart E (15.407)**

**789033 D02 General UNII Test Procedures New Rules v01r02**

**644545 D01 Guidance for IEEE 802 11ac v01r02**

**662911 D01 Multiple Transmitter Output v02r01**

**ANSI C63.10-2013**

All test items have been performed and recorded as per the above standards.

**NOTE:** The EUT has been verified to comply with the requirements of FCC Part 15, Subpart B, Class B (DoC).  
The test report has been issued separately.

## 4 Test Types and Results

### 4.1 Radiated Emission and Bandedge Measurement

#### 4.1.1 Limits of Radiated Emission and Bandedge Measurement

Radiated emissions which fall in the restricted bands must comply with the radiated emission limits specified as below table. Other emissions shall be at least 20 dB below the highest level of the desired power:

Frequencies (MHz)	Field Strength (microvolts/meter)	Measurement Distance (meters)
0.009 ~ 0.490	2400/F (kHz)	300
0.490 ~ 1.705	24000/F (kHz)	30
1.705 ~ 30.0	30	30
30 ~ 88	100	3
88 ~ 216	150	3
216 ~ 960	200	3
Above 960	500	3

#### NOTE:

1. The lower limit shall apply at the transition frequencies.
2. Emission level (dBuV/m) = 20 log Emission level (uV/m).
3. For frequencies above 1000 MHz, the field strength limits are based on average detector, however, the peak field strength of any emission shall not exceed the maximum permitted average limits, specified above by more than 20 dB under any condition of modulation.

#### 4.1.2 Limits of Unwanted Emission Out of the Restricted Bands

Applicable To	Limit	
789033 D02 General UNII Test Procedures New Rules v01r02	Field Strength at 3 m	
	PK: 74 (dBμV/m)	AV: 54 (dBμV/m)
Applicable To	EIRP Limit	Equivalent Field Strength at 3 m
15.407(b)(1)	PK: -27 (dBm/MHz)	PK: 68.2 (dBμV/m)
15.407(b)(2)		
15.407(b)(3)		
15.407(b)(4)	PK: -27 (dBm/MHz) <sup>*1</sup> PK: -17 (dBm/MHz) <sup>*2</sup>	PK: 68.2 (dBμV/m) <sup>*1</sup> PK: 78.2 (dBμV/m) <sup>*2</sup>

**NOTE:** <sup>\*1</sup> beyond 10 MHz of the band edge <sup>\*2</sup> within 10 MHz of band edge

The following formula is used to convert the equipment isotropic radiated power (eirp) to field strength:

$$E = \frac{1000000\sqrt{30P}}{3} \mu\text{V/m, where P is the eirp (Watts).}$$

#### 4.1.3 Test Instruments

Description & Manufacturer	Model No.	Serial No.	Date of Calibration	Due Date of Calibration
Test Receiver Agilent	N9038A	MY51210203	Jan. 21, 2016	Jan. 20, 2017
Spectrum Analyzer Agilent	N9010A	MY52220314	Sep. 03, 2015	Sep. 02, 2016
Spectrum Analyzer ROHDE & SCHWARZ	FSU43	101261	Dec. 17, 2015	Dec. 16, 2016
BILOG Antenna SCHWARZBECK	VULB9168	9168-472	Jan. 07, 2016	Jan. 06, 2017
HORN Antenna SCHWARZBECK	BBHA 9120 D	9120D-969	Jan. 18, 2016	Jan. 17, 2017
HORN Antenna SCHWARZBECK	BBHA 9170	9170-480	Jan. 08, 2016	Jan. 07, 2017
Loop Antenna	EM-6879	269	Jul. 31, 2015	Jul. 30, 2016
Bluetooth Tester	CBT	100980	Apr. 27, 2015	Apr. 26, 2017
Agilent Communications Tester-Wireless	8960 Series 10	MY53201073	Jul. 03, 2015	Jul. 02, 2017
Preamplifier EMCI	EMC 012645	980115	Dec. 21, 2015	Dec. 20, 2016
Preamplifier EMCI	EMC 184045	980116	Dec. 21, 2015	Dec. 20, 2016
Preamplifier EMCI	EMC 330H	980112	Dec. 28, 2015	Dec. 27, 2016
Power Meter Anritsu	ML2495A	1232002	Sep. 21, 2015	Sep. 20, 2016
Power Sensor Anritsu	MA2411B	1207325	Sep. 21, 2015	Sep. 20, 2016
RF signal cable HUBER+SUHNNER	SUCOFLEX 104	309219/4 2950114	Oct. 12, 2015	Oct. 11, 2016
RF signal cable HUBER+SUHNNER	SUCOFLEX 104	250130/4	Oct. 12, 2015	Oct. 11, 2016
RF Coaxial Cable Worken	8D-FB	Cable-Ch10-01	Oct. 12, 2015	Oct. 11, 2016
Software BV ADT	E3 6.120103	NA	NA	NA
Antenna Tower MF	MFA-440H	NA	NA	NA
Turn Table MF	MFT-201SS	NA	NA	NA
Antenna Tower & Turn Table Controller MF	MF-7802	NA	NA	NA

Note: 1. The calibration interval of the above test instruments is 12 / 24 months and the calibrations are traceable to NML/ROC and NIST/USA.

2. The test was performed in HwaYa Chamber 10.

3. The horn antenna and preamplifier (model: EMC 184045) are used only for the measurement of emission frequency above 1 GHz if tested.

4. The FCC Site Registration No. is 690701.

5. The IC Site Registration No. is IC7450F-10.

#### 4.1.4 Test Procedures

- a. The EUT was placed on the top of a rotating table 0.8 meters (for below 1 GHz) / 1.5 meters (for above 1 GHz) above the ground at 3 meter chamber room for test. The table was rotated 360 degrees to determine the position of the highest radiation.
- b. The EUT was set 3 meters away from the interference-receiving antenna, which was mounted on the top of a variable-height antenna tower.
- c. The height of antenna is varied from one meter to four meters above the ground to determine the maximum value of the field strength. Both horizontal and vertical polarizations of the antenna are set to make the measurement.
- d. For each suspected emission, the EUT was arranged to its worst case and then the antenna was tuned to heights from 1 meter to 4 meters and the rotatable table was turned from 0 degrees to 360 degrees to find the maximum reading.
- e. The test-receiver system was set to quasi-peak detect function and specified bandwidth with maximum hold mode when the test frequency is below 1 GHz.
- f. The test-receiver system was set to peak and average detected function and specified bandwidth with maximum hold mode when the test frequency is above 1 GHz. If the peak reading value also meets average limit, measurement with the average detector is unnecessary.

**Note:**

1. The resolution bandwidth and video bandwidth of test receiver/spectrum analyzer is 120 kHz for Quasi-peak detection (QP) at frequency below 1 GHz.
2. The resolution bandwidth of test receiver/spectrum analyzer is 1 MHz and the video bandwidth is 3 MHz for Peak detection (PK) at frequency above 1 GHz.
3. The resolution bandwidth of test receiver/spectrum analyzer is 1 MHz and the video bandwidth is 3 MHz for RMS Average (Duty cycle < 98 %) for Average detection (AV) at frequency above 1 GHz, then the measurement results was added to a correction factor ( $10 \log(1/\text{duty cycle})$ ).
4. The resolution bandwidth of test receiver/spectrum analyzer is 1 MHz and the video bandwidth is 10 Hz (Duty cycle  $\geq$  98 %) for Average detection (AV) at frequency above 1 GHz.
5. All modes of operation were investigated and the worst-case emissions are reported.

#### 4.1.5 Deviation from Test Standard

No deviation.

#### 4.1.6 Test Set Up

##### <Frequency Range below 1 GHz>

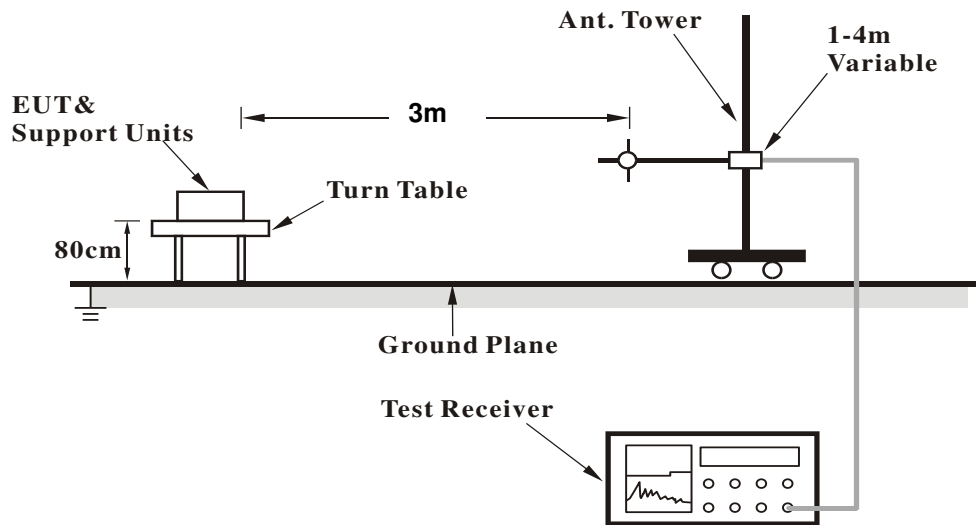

##### <Frequency Range above 1 GHz>

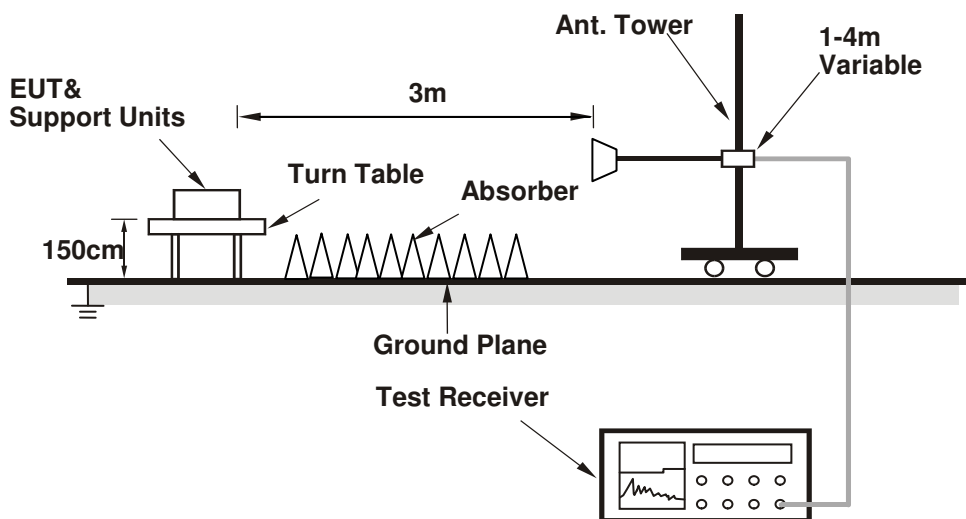

For the actual test configuration, please refer to the attached file (Test Setup Photo).

#### 4.1.7 EUT Operating Conditions

- Placed the EUT on a testing table.
- Use the software to control the EUT under transmission condition continuously at specific channel frequency.



#### 4.1.8 Test Results

#### Above 1 GHz Data :

#### Mode A

#### 802.11a

EUT Test Condition		Measurement Detail	
Channel	Channel 36	Frequency Range	1 GHz ~ 40 GHz
Input Power	120 Vac, 60 Hz	Detector Function	Peak (PK) Average (AV)
Environmental Conditions	25 deg. C, 65 % RH	Tested By	Toby Tian

Antenna Polarity & Test Distance: Horizontal at 3 m										
Frequency (MHz)	Emission Level (dBuV/m)	Read Level (dBuV)	Limit (dBuV/m)	Margin (dB)	Antenna Factor (dB/m)	Cable Loss (dB)	Preamp Factor (dB)	Antenna Height (cm)	Table Angle (Degree)	Remark
5146	42.91	42.71	54	-11.09	31.32	6.2	37.32	203	62	Average
5146	60.79	60.59	74	-13.21	31.32	6.2	37.32	203	62	Peak
5180	92.84	92.61			31.35	6.22	37.34	203	62	Average
5180	102.69	102.46			31.35	6.22	37.34	203	62	Peak
5442	38.53	37.77	54	-15.47	31.55	6.34	37.13	203	62	Average
5442	60.25	59.49	74	-13.75	31.55	6.34	37.13	203	62	Peak

Antenna Polarity & Test Distance: Vertical at 3 m										
Frequency (MHz)	Emission Level (dBuV/m)	Read Level (dBuV)	Limit (dBuV/m)	Margin (dB)	Antenna Factor (dB/m)	Cable Loss (dB)	Preamp Factor (dB)	Antenna Height (cm)	Table Angle (Degree)	Remark
5150	44.73	44.53	54	-9.27	31.32	6.2	37.32	198	34	Average
5150	61.07	60.87	74	-12.93	31.32	6.2	37.32	198	34	Peak
5180	95.2	94.97			31.35	6.22	37.34	198	34	Average
5180	105.18	104.95			31.35	6.22	37.34	198	34	Peak
5376	38.68	38.06	54	-15.32	31.49	6.31	37.18	198	34	Average
5376	60.92	60.3	74	-13.08	31.49	6.31	37.18	198	34	Peak

#### Remarks:

- Emission Level = Read Level + Antenna Factor + Cable Loss - Preamp Factor  
Margin value = Emission level – Limit value
- 5180 MHz: Fundamental Frequency

EUT Test Condition		Measurement Detail	
Channel	Channel 44	Frequency Range	1 GHz ~ 40 GHz
Input Power	120 Vac, 60 Hz	Detector Function	Peak (PK) Average (AV)
Environmental Conditions	25 deg. C, 65 % RH	Tested By	Toby Tian

Antenna Polarity & Test Distance: Horizontal at 3 m										
Frequency (MHz)	Emission Level (dBuV/m)	Read Level (dBuV)	Limit (dBuV/m)	Margin (dB)	Antenna Factor (dB/m)	Cable Loss (dB)	Preamp Factor (dB)	Antenna Height (cm)	Table Angle (Degree)	Remark
5034	39.26	39.12	54	-14.74	31.23	6.15	37.24	202	58	Average
5034	60.26	60.12	74	-13.74	31.23	6.15	37.24	202	58	Peak
5220	91.97	91.72			31.37	6.24	37.36	202	58	Average
5220	102.68	102.43			31.37	6.24	37.36	202	58	Peak
5450	38.75	37.93	54	-15.25	31.56	6.34	37.08	202	58	Average
5450	60.13	59.31	74	-13.87	31.56	6.34	37.08	202	58	Peak
Antenna Polarity & Test Distance: Vertical at 3 m										
Frequency (MHz)	Emission Level (dBuV/m)	Read Level (dBuV)	Limit (dBuV/m)	Margin (dB)	Antenna Factor (dB/m)	Cable Loss (dB)	Preamp Factor (dB)	Antenna Height (cm)	Table Angle (Degree)	Remark
5148	39.47	39.27	54	-14.53	31.32	6.2	37.32	198	28	Average
5148	61.03	60.83	74	-12.97	31.32	6.2	37.32	198	28	Peak
5220	94.38	94.13			31.37	6.24	37.36	198	28	Average
5220	105.24	104.99			31.37	6.24	37.36	198	28	Peak
5416	38.82	38.15	54	-15.18	31.53	6.32	37.18	198	28	Average
5416	60.19	59.52	74	-13.81	31.53	6.32	37.18	198	28	Peak

Remarks:

- Emission Level = Read Level + Antenna Factor + Cable Loss - Preamp Factor  
Margin value = Emission level – Limit value
- 5220 MHz: Fundamental Frequency

EUT Test Condition		Measurement Detail	
Channel	Channel 48	Frequency Range	1 GHz ~ 40 GHz
Input Power	120 Vac, 60 Hz	Detector Function	Peak (PK) Average (AV)
Environmental Conditions	25 deg. C, 65 % RH	Tested By	Toby Tian

Antenna Polarity & Test Distance: Horizontal at 3 m										
Frequency (MHz)	Emission Level (dBuV/m)	Read Level (dBuV)	Limit (dBuV/m)	Margin (dB)	Antenna Factor (dB/m)	Cable Loss (dB)	Preamp Factor (dB)	Antenna Height (cm)	Table Angle (Degree)	Remark
5014	38.36	38.23	54	-15.64	31.21	6.15	37.23	200	60	Average
5014	60.81	60.68	74	-13.19	31.21	6.15	37.23	200	60	Peak
5240	92.13	91.81			31.39	6.25	37.32	200	60	Average
5240	102.82	102.5			31.39	6.25	37.32	200	60	Peak
5454	38.62	37.8	54	-15.38	31.56	6.34	37.08	200	60	Average
5454	60.98	60.16	74	-13.02	31.56	6.34	37.08	200	60	Peak
Antenna Polarity & Test Distance: Vertical at 3 m										
Frequency (MHz)	Emission Level (dBuV/m)	Read Level (dBuV)	Limit (dBuV/m)	Margin (dB)	Antenna Factor (dB/m)	Cable Loss (dB)	Preamp Factor (dB)	Antenna Height (cm)	Table Angle (Degree)	Remark
5090	39.14	38.94	54	-14.86	31.28	6.19	37.27	199	21	Average
5090	61.42	61.22	74	-12.58	31.28	6.19	37.27	199	21	Peak
5240	95.62	95.3			31.39	6.25	37.32	199	21	Average
5240	105.46	105.14			31.39	6.25	37.32	199	21	Peak
5430	38.63	37.89	54	-15.37	31.55	6.32	37.13	199	21	Average
5430	60.23	59.49	74	-13.77	31.55	6.32	37.13	199	21	Peak

Remarks:

- Emission Level = Read Level + Antenna Factor + Cable Loss - Preamp Factor  
Margin value = Emission level – Limit value
- 5240 MHz: Fundamental Frequency

EUT Test Condition		Measurement Detail	
Channel	Channel 52	Frequency Range	1 GHz ~ 40 GHz
Input Power	120 Vac, 60 Hz	Detector Function	Peak (PK) Average (AV)
Environmental Conditions	25 deg. C, 65 % RH	Tested By	Toby Tian

Antenna Polarity & Test Distance: Horizontal at 3 m										
Frequency (MHz)	Emission Level (dBuV/m)	Read Level (dBuV)	Limit (dBuV/m)	Margin (dB)	Antenna Factor (dB/m)	Cable Loss (dB)	Preamp Factor (dB)	Antenna Height (cm)	Table Angle (Degree)	Remark
5054	38.51	38.35	54	-15.49	31.24	6.17	37.25	200	54	Average
5054	60.02	59.86	74	-13.98	31.24	6.17	37.25	200	54	Peak
5260	93.07	92.68			31.41	6.25	37.27	200	54	Average
5260	103.9	103.51			31.41	6.25	37.27	200	54	Peak
5458	38.74	37.92	54	-15.26	31.56	6.34	37.08	200	54	Average
5458	60.34	59.52	74	-13.66	31.56	6.34	37.08	200	54	Peak
Antenna Polarity & Test Distance: Vertical at 3 m										
Frequency (MHz)	Emission Level (dBuV/m)	Read Level (dBuV)	Limit (dBuV/m)	Margin (dB)	Antenna Factor (dB/m)	Cable Loss (dB)	Preamp Factor (dB)	Antenna Height (cm)	Table Angle (Degree)	Remark
5132	38.96	38.75	54	-15.04	31.31	6.2	37.3	180	30	Average
5132	60.19	59.98	74	-13.81	31.31	6.2	37.3	180	30	Peak
5260	96	95.61			31.41	6.25	37.27	180	30	Average
5260	106.65	106.26			31.41	6.25	37.27	180	30	Peak
5434	38.77	38.03	54	-15.23	31.55	6.32	37.13	180	30	Average
5434	60.5	59.76	74	-13.5	31.55	6.32	37.13	180	30	Peak

Remarks:

- Emission Level = Read Level + Antenna Factor + Cable Loss - Preamp Factor  
Margin value = Emission level – Limit value
- 5260 MHz: Fundamental Frequency

EUT Test Condition		Measurement Detail	
Channel	Channel 60	Frequency Range	1 GHz ~ 40 GHz
Input Power	120 Vac, 60 Hz	Detector Function	Peak (PK) Average (AV)
Environmental Conditions	25 deg. C, 65 % RH	Tested By	Toby Tian

Antenna Polarity & Test Distance: Horizontal at 3 m										
Frequency (MHz)	Emission Level (dBuV/m)	Read Level (dBuV)	Limit (dBuV/m)	Margin (dB)	Antenna Factor (dB/m)	Cable Loss (dB)	Preamp Factor (dB)	Antenna Height (cm)	Table Angle (Degree)	Remark
5034	38.38	38.24	54	-15.62	31.23	6.15	37.24	192	49	Average
5034	60.37	60.23	74	-13.63	31.23	6.15	37.24	192	49	Peak
5300	93.84	93.32			31.44	6.27	37.19	192	49	Average
5300	103.81	103.29			31.44	6.27	37.19	192	49	Peak
5396	39.11	38.46	54	-14.89	31.52	6.31	37.18	192	49	Average
5396	59.78	59.13	74	-14.22	31.52	6.31	37.18	192	49	Peak
Antenna Polarity & Test Distance: Vertical at 3 m										
Frequency (MHz)	Emission Level (dBuV/m)	Read Level (dBuV)	Limit (dBuV/m)	Margin (dB)	Antenna Factor (dB/m)	Cable Loss (dB)	Preamp Factor (dB)	Antenna Height (cm)	Table Angle (Degree)	Remark
5086	38.76	38.59	54	-15.24	31.27	6.17	37.27	179	27	Average
5086	59.52	59.35	74	-14.48	31.27	6.17	37.27	179	27	Peak
5300	96	95.48			31.44	6.27	37.19	179	27	Average
5300	106.57	106.05			31.44	6.27	37.19	179	27	Peak
5424	39.19	38.52	54	-14.81	31.53	6.32	37.18	179	27	Average
5424	60.58	59.91	74	-13.42	31.53	6.32	37.18	179	27	Peak

Remarks:

- Emission Level = Read Level + Antenna Factor + Cable Loss - Preamp Factor  
Margin value = Emission level – Limit value
- 5300 MHz: Fundamental Frequency

EUT Test Condition		Measurement Detail	
Channel	Channel 64	Frequency Range	1 GHz ~ 40 GHz
Input Power	120 Vac, 60 Hz	Detector Function	Peak (PK) Average (AV)
Environmental Conditions	25 deg. C, 65 % RH	Tested By	Toby Tian

Antenna Polarity & Test Distance: Horizontal at 3 m										
Frequency (MHz)	Emission Level (dBuV/m)	Read Level (dBuV)	Limit (dBuV/m)	Margin (dB)	Antenna Factor (dB/m)	Cable Loss (dB)	Preamp Factor (dB)	Antenna Height (cm)	Table Angle (Degree)	Remark
5104	38.35	38.16	54	-15.65	31.28	6.19	37.28	190	53	Average
5104	59.88	59.69	74	-14.12	31.28	6.19	37.28	190	53	Peak
5320	93.91	93.36			31.45	6.29	37.19	190	53	Average
5320	103.87	103.32			31.45	6.29	37.19	190	53	Peak
5350	42.09	41.5	54	-11.91	31.48	6.29	37.18	190	53	Average
5350	63.14	62.55	74	-10.86	31.48	6.29	37.18	190	53	Peak
Antenna Polarity & Test Distance: Vertical at 3 m										
Frequency (MHz)	Emission Level (dBuV/m)	Read Level (dBuV)	Limit (dBuV/m)	Margin (dB)	Antenna Factor (dB/m)	Cable Loss (dB)	Preamp Factor (dB)	Antenna Height (cm)	Table Angle (Degree)	Remark
5146	38.72	38.52	54	-15.28	31.32	6.2	37.32	177	28	Average
5146	60.38	60.18	74	-13.62	31.32	6.2	37.32	177	28	Peak
5320	96.05	95.5			31.45	6.29	37.19	177	28	Average
5320	106.43	105.88			31.45	6.29	37.19	177	28	Peak
5352	43.75	43.16	54	-10.25	31.48	6.29	37.18	177	28	Average
5352	64.42	63.83	74	-9.58	31.48	6.29	37.18	177	28	Peak

Remarks:

- Emission Level = Read Level + Antenna Factor + Cable Loss - Preamp Factor  
Margin value = Emission level – Limit value
- 5320 MHz: Fundamental Frequency

EUT Test Condition		Measurement Detail	
Channel	Channel 100	Frequency Range	1 GHz ~ 40 GHz
Input Power	120 Vac, 60 Hz	Detector Function	Peak (PK) Average (AV)
Environmental Conditions	25 deg. C, 65 % RH	Tested By	Anson Lin

Antenna Polarity & Test Distance: Horizontal at 3 m										
Frequency (MHz)	Emission Level (dBuV/m)	Read Level (dBuV)	Limit (dBuV/m)	Margin (dB)	Antenna Factor (dB/m)	Cable Loss (dB)	Preamp Factor (dB)	Antenna Height (cm)	Table Angle (Degree)	Remark
5434	40.76	40.02	54	-13.24	31.55	6.32	37.13	100	57	Average
5434	60.72	59.98	74	-13.28	31.55	6.32	37.13	100	57	Peak
5470	60.15	59.32	68.2	-8.05	31.57	6.34	37.08	100	57	Peak
5500	88.63	87.7			31.6	6.36	37.03	100	57	Average
5500	98.83	97.9			31.6	6.36	37.03	100	57	Peak
5725	60	58.72	68.2	-8.2	31.96	6.75	37.43	100	57	Peak
Antenna Polarity & Test Distance: Vertical at 3 m										
Frequency (MHz)	Emission Level (dBuV/m)	Read Level (dBuV)	Limit (dBuV/m)	Margin (dB)	Antenna Factor (dB/m)	Cable Loss (dB)	Preamp Factor (dB)	Antenna Height (cm)	Table Angle (Degree)	Remark
5394	41.23	40.59	54	-12.77	31.51	6.31	37.18	219	22	Average
5394	60.53	59.89	74	-13.47	31.51	6.31	37.18	219	22	Peak
5470	60.62	59.79	68.2	-7.58	31.57	6.34	37.08	219	22	Peak
5500	94.14	93.21			31.6	6.36	37.03	219	22	Average
5500	104.39	103.46			31.6	6.36	37.03	219	22	Peak
5725	60.23	58.95	68.2	-7.97	31.96	6.75	37.43	219	22	Peak

Remarks:

- Emission Level = Read Level + Antenna Factor + Cable Loss - Preamp Factor  
Margin value = Emission level – Limit value
- 5500 MHz: Fundamental Frequency
- 5470 MHz & 5725 MHz: Out of Restricted Band

EUT Test Condition		Measurement Detail	
Channel	Channel 116	Frequency Range	1 GHz ~ 40 GHz
Input Power	120 Vac, 60 Hz	Detector Function	Peak (PK) Average (AV)
Environmental Conditions	25 deg. C, 65 % RH	Tested By	Anson Lin

Antenna Polarity & Test Distance: Horizontal at 3 m										
Frequency (MHz)	Emission Level (dBuV/m)	Read Level (dBuV)	Limit (dBuV/m)	Margin (dB)	Antenna Factor (dB/m)	Cable Loss (dB)	Preamp Factor (dB)	Antenna Height (cm)	Table Angle (Degree)	Remark
5448	40.57	39.8	54	-13.43	31.56	6.34	37.13	100	57	Average
5448	60.33	59.56	74	-13.67	31.56	6.34	37.13	100	57	Peak
5470	58.36	57.53	68.2	-9.84	31.57	6.34	37.08	100	57	Peak
5580	89.41	88.37			31.71	6.49	37.16	100	57	Average
5580	99.13	98.09			31.71	6.49	37.16	100	57	Peak
5725	60	58.72	68.2	-8.2	31.96	6.75	37.43	100	57	Peak
Antenna Polarity & Test Distance: Vertical at 3 m										
Frequency (MHz)	Emission Level (dBuV/m)	Read Level (dBuV)	Limit (dBuV/m)	Margin (dB)	Antenna Factor (dB/m)	Cable Loss (dB)	Preamp Factor (dB)	Antenna Height (cm)	Table Angle (Degree)	Remark
5458	40.66	39.84	54	-13.34	31.56	6.34	37.08	221	20	Average
5458	61.47	60.65	74	-12.53	31.56	6.34	37.08	221	20	Peak
5470	60.47	59.64	68.2	-7.73	31.57	6.34	37.08	221	20	Peak
5580	95.79	94.75			31.71	6.49	37.16	221	20	Average
5580	105.33	104.29			31.71	6.49	37.16	221	20	Peak
5725	61.66	60.38	68.2	-6.54	31.96	6.75	37.43	221	20	Peak

Remarks:

- Emission Level = Read Level + Antenna Factor + Cable Loss - Preamp Factor  
Margin value = Emission level – Limit value
- 5580 MHz: Fundamental Frequency
- 5470 MHz & 5725 MHz: Out of Restricted Band



EUT Test Condition		Measurement Detail	
Channel	Channel 140	Frequency Range	1 GHz ~ 40 GHz
Input Power	120 Vac, 60 Hz	Detector Function	Peak (PK) Average (AV)
Environmental Conditions	25 deg. C, 65 % RH	Tested By	Anson Lin

Antenna Polarity & Test Distance: Horizontal at 3 m										
Frequency (MHz)	Emission Level (dBuV/m)	Read Level (dBuV)	Limit (dBuV/m)	Margin (dB)	Antenna Factor (dB/m)	Cable Loss (dB)	Preamp Factor (dB)	Antenna Height (cm)	Table Angle (Degree)	Remark
5460	40.83	40.01	54	-13.17	31.56	6.34	37.08	103	67	Average
5460	60.65	59.83	74	-13.35	31.56	6.34	37.08	103	67	Peak
5470	58.65	57.82	68.2	-9.55	31.57	6.34	37.08	103	67	Peak
5700	90.3	89.11			31.9	6.69	37.4	103	67	Average
5700	100.38	99.19			31.9	6.69	37.4	103	67	Peak
5725	61.27	59.99	68.2	-6.93	31.96	6.75	37.43	103	67	Peak
Antenna Polarity & Test Distance: Vertical at 3 m										
Frequency (MHz)	Emission Level (dBuV/m)	Read Level (dBuV)	Limit (dBuV/m)	Margin (dB)	Antenna Factor (dB/m)	Cable Loss (dB)	Preamp Factor (dB)	Antenna Height (cm)	Table Angle (Degree)	Remark
5420	40.53	39.86	54	-13.47	31.53	6.32	37.18	217	19	Average
5420	60.82	60.15	74	-13.18	31.53	6.32	37.18	217	19	Peak
5470	60.15	59.32	68.2	-8.05	31.57	6.34	37.08	217	19	Peak
5700	94.47	93.28			31.9	6.69	37.4	217	19	Average
5700	104.7	103.51			31.9	6.69	37.4	217	19	Peak
5725	62.8	61.52	68.2	-5.4	31.96	6.75	37.43	217	19	Peak

Remarks:

- Emission Level = Read Level + Antenna Factor + Cable Loss - Preamp Factor  
Margin value = Emission level – Limit value
- 5700 MHz: Fundamental Frequency
- 5470 MHz & 5725 MHz: Out of Restricted Band

EUT Test Condition		Measurement Detail	
Channel	Channel 149	Frequency Range	1 GHz ~ 40 GHz
Input Power	120 Vac, 60 Hz	Detector Function	Peak (PK) Average (AV)
Environmental Conditions	25 deg. C, 65 % RH	Tested By	Gavin Wu

Antenna Polarity & Test Distance: Horizontal at 3 m										
Frequency (MHz)	Emission Level (dBuV/m)	Read Level (dBuV)	Limit (dBuV/m)	Margin (dB)	Antenna Factor (dB/m)	Cable Loss (dB)	Preamp Factor (dB)	Antenna Height (cm)	Table Angle (Degree)	Remark
*5714	60.42	59.23	68.2	-7.78	31.93	6.69	37.43	194	63	Peak
*5725	67.37	66.09	78.2	-10.83	31.96	6.75	37.43	194	63	Peak
5745	95	93.73			31.99	6.75	37.47	194	63	Average
5745	105.58	104.31			31.99	6.75	37.47	194	63	Peak
*5850	58.84	57.32	78.2	-19.36	32.15	6.88	37.51	194	63	Peak
*5861	60.14	58.51	68.2	-8.06	32.18	6.95	37.5	194	63	Peak
Antenna Polarity & Test Distance: Vertical at 3 m										
Frequency (MHz)	Emission Level (dBuV/m)	Read Level (dBuV)	Limit (dBuV/m)	Margin (dB)	Antenna Factor (dB/m)	Cable Loss (dB)	Preamp Factor (dB)	Antenna Height (cm)	Table Angle (Degree)	Remark
*5714	60.13	58.94	68.2	-8.07	31.93	6.69	37.43	199	15	Peak
*5725	65.16	63.88	78.2	-13.04	31.96	6.75	37.43	199	15	Peak
5745	93.2	91.93			31.99	6.75	37.47	199	15	Average
5745	103.38	102.11			31.99	6.75	37.47	199	15	Peak
*5850	59.87	58.35	78.2	-18.33	32.15	6.88	37.51	199	15	Peak
*5861	58.95	57.32	68.2	-9.25	32.18	6.95	37.5	199	15	Peak

Remarks:

- Emission Level = Read Level + Antenna Factor + Cable Loss - Preamp Factor  
Margin value = Emission level – Limit value
- 5745 MHz: Fundamental Frequency
- \*: Out of Restricted Band

EUT Test Condition		Measurement Detail	
Channel	Channel 157	Frequency Range	1 GHz ~ 40 GHz
Input Power	120 Vac, 60 Hz	Detector Function	Peak (PK) Average (AV)
Environmental Conditions	25 deg. C, 65 % RH	Tested By	Gavin Wu

Antenna Polarity & Test Distance: Horizontal at 3 m										
Frequency (MHz)	Emission Level (dBuV/m)	Read Level (dBuV)	Limit (dBuV/m)	Margin (dB)	Antenna Factor (dB/m)	Cable Loss (dB)	Preamp Factor (dB)	Antenna Height (cm)	Table Angle (Degree)	Remark
*5714	59.06	57.87	68.2	-9.14	31.93	6.69	37.43	195	63	Peak
*5725	59.51	58.23	78.2	-18.69	31.96	6.75	37.43	195	63	Peak
5785	95.97	94.65			32.04	6.82	37.54	195	63	Average
5785	105.15	103.83			32.04	6.82	37.54	195	63	Peak
*5850	60.97	59.45	78.2	-17.23	32.15	6.88	37.51	195	63	Peak
*5861	59.14	57.51	68.2	-9.06	32.18	6.95	37.5	195	63	Peak

Antenna Polarity & Test Distance: Vertical at 3 m										
Frequency (MHz)	Emission Level (dBuV/m)	Read Level (dBuV)	Limit (dBuV/m)	Margin (dB)	Antenna Factor (dB/m)	Cable Loss (dB)	Preamp Factor (dB)	Antenna Height (cm)	Table Angle (Degree)	Remark
*5714	59.57	58.38	68.2	-8.63	31.93	6.69	37.43	197	13	Peak
*5725	59.06	57.78	78.2	-19.14	31.96	6.75	37.43	197	13	Peak
5785	93.12	91.8			32.04	6.82	37.54	197	13	Average
5785	103.73	102.41			32.04	6.82	37.54	197	13	Peak
*5850	59.56	58.04	78.2	-18.64	32.15	6.88	37.51	197	13	Peak
*5861	60.08	58.45	68.2	-8.12	32.18	6.95	37.5	197	13	Peak

Remarks:

- Emission Level = Read Level + Antenna Factor + Cable Loss - Preamp Factor  
Margin value = Emission level – Limit value
- 5785 MHz: Fundamental Frequency
- \*: Out of Restricted Band

EUT Test Condition		Measurement Detail	
Channel	Channel 165	Frequency Range	1 GHz ~ 40 GHz
Input Power	120 Vac, 60 Hz	Detector Function	Peak (PK) Average (AV)
Environmental Conditions	25 deg. C, 65 % RH	Tested By	Gavin Wu

Antenna Polarity & Test Distance: Horizontal at 3 m										
Frequency (MHz)	Emission Level (dBuV/m)	Read Level (dBuV)	Limit (dBuV/m)	Margin (dB)	Antenna Factor (dB/m)	Cable Loss (dB)	Preamp Factor (dB)	Antenna Height (cm)	Table Angle (Degree)	Remark
*5714	60.37	59.18	68.2	-7.83	31.93	6.69	37.43	195	62	Peak
*5725	59.08	57.8	78.2	-19.12	31.96	6.75	37.43	195	62	Peak
5825	95.55	94.08			32.12	6.88	37.53	195	62	Average
5825	105.26	103.79			32.12	6.88	37.53	195	62	Peak
*5850	62.78	61.26	78.2	-15.42	32.15	6.88	37.51	195	62	Peak
*5861	62.47	60.84	68.2	-5.73	32.18	6.95	37.5	195	62	Peak
Antenna Polarity & Test Distance: Vertical at 3 m										
Frequency (MHz)	Emission Level (dBuV/m)	Read Level (dBuV)	Limit (dBuV/m)	Margin (dB)	Antenna Factor (dB/m)	Cable Loss (dB)	Preamp Factor (dB)	Antenna Height (cm)	Table Angle (Degree)	Remark
*5714	58.15	56.96	68.2	-10.05	31.93	6.69	37.43	197	14	Peak
*5725	60.26	58.98	78.2	-17.94	31.96	6.75	37.43	197	14	Peak
5825	93.22	91.75			32.12	6.88	37.53	197	14	Average
5825	103.08	101.61			32.12	6.88	37.53	197	14	Peak
*5850	62.44	60.92	78.2	-15.76	32.15	6.88	37.51	197	14	Peak
*5861	60.97	59.34	68.2	-7.23	32.18	6.95	37.5	197	14	Peak

Remarks:

- Emission Level = Read Level + Antenna Factor + Cable Loss - Preamp Factor  
Margin value = Emission level – Limit value
- 5825 MHz: Fundamental Frequency
- \*: Out of Restricted Band

### 802.11n (HT20)

EUT Test Condition		Measurement Detail	
Channel	Channel 36	Frequency Range	1 GHz ~ 40 GHz
Input Power	120 Vac, 60 Hz	Detector Function	Peak (PK) Average (AV)
Environmental Conditions	25 deg. C, 65 % RH	Tested By	Toby Tian

#### Antenna Polarity & Test Distance: Horizontal at 3 m

Frequency (MHz)	Emission Level (dBuV/m)	Read Level (dBuV)	Limit (dBuV/m)	Margin (dB)	Antenna Factor (dB/m)	Cable Loss (dB)	Preamp Factor (dB)	Antenna Height (cm)	Table Angle (Degree)	Remark
5054	39.15	38.99	54	-14.85	31.24	6.17	37.25	203	64	Average
5054	59.82	59.66	74	-14.18	31.24	6.17	37.25	203	64	Peak
5180	88.63	88.4			31.35	6.22	37.34	203	64	Average
5180	98.52	98.29			31.35	6.22	37.34	203	64	Peak
5418	38.45	37.78	54	-15.55	31.53	6.32	37.18	203	64	Average
5418	60.82	60.15	74	-13.18	31.53	6.32	37.18	203	64	Peak

#### Antenna Polarity & Test Distance: Vertical at 3 m

Frequency (MHz)	Emission Level (dBuV/m)	Read Level (dBuV)	Limit (dBuV/m)	Margin (dB)	Antenna Factor (dB/m)	Cable Loss (dB)	Preamp Factor (dB)	Antenna Height (cm)	Table Angle (Degree)	Remark
5130	40.16	39.95	54	-13.84	31.31	6.2	37.3	202	33	Average
5130	61.08	60.87	74	-12.92	31.31	6.2	37.3	202	33	Peak
5180	90.14	89.91			31.35	6.22	37.34	202	33	Average
5180	100.92	100.69			31.35	6.22	37.34	202	33	Peak
5436	38.63	37.89	54	-15.37	31.55	6.32	37.13	202	33	Average
5436	60.71	59.97	74	-13.29	31.55	6.32	37.13	202	33	Peak

Remarks:

- Emission Level = Read Level + Antenna Factor + Cable Loss - Preamp Factor  
Margin value = Emission level – Limit value
- 5180 MHz: Fundamental Frequency

EUT Test Condition		Measurement Detail	
Channel	Channel 44	Frequency Range	1 GHz ~ 40 GHz
Input Power	120 Vac, 60 Hz	Detector Function	Peak (PK) Average (AV)
Environmental Conditions	25 deg. C, 65 % RH	Tested By	Toby Tian

Antenna Polarity & Test Distance: Horizontal at 3 m										
Frequency (MHz)	Emission Level (dBuV/m)	Read Level (dBuV)	Limit (dBuV/m)	Margin (dB)	Antenna Factor (dB/m)	Cable Loss (dB)	Preamp Factor (dB)	Antenna Height (cm)	Table Angle (Degree)	Remark
5144	38.43	38.23	54	-15.57	31.32	6.2	37.32	202	56	Average
5144	60.16	59.96	74	-13.84	31.32	6.2	37.32	202	56	Peak
5220	88.81	88.56			31.37	6.24	37.36	202	56	Average
5220	98.57	98.32			31.37	6.24	37.36	202	56	Peak
5436	38.57	37.83	54	-15.43	31.55	6.32	37.13	202	56	Average
5436	60.33	59.59	74	-13.67	31.55	6.32	37.13	202	56	Peak
Antenna Polarity & Test Distance: Vertical at 3 m										
Frequency (MHz)	Emission Level (dBuV/m)	Read Level (dBuV)	Limit (dBuV/m)	Margin (dB)	Antenna Factor (dB/m)	Cable Loss (dB)	Preamp Factor (dB)	Antenna Height (cm)	Table Angle (Degree)	Remark
5134	38.72	38.51	54	-15.28	31.31	6.2	37.3	201	36	Average
5134	60.92	60.71	74	-13.08	31.31	6.2	37.3	201	36	Peak
5220	91.43	91.18			31.37	6.24	37.36	201	36	Average
5220	101	100.75			31.37	6.24	37.36	201	36	Peak
5392	38.61	37.97	54	-15.39	31.51	6.31	37.18	201	36	Average
5392	60.45	59.81	74	-13.55	31.51	6.31	37.18	201	36	Peak

Remarks:

- Emission Level = Read Level + Antenna Factor + Cable Loss - Preamp Factor  
Margin value = Emission level – Limit value
- 5220 MHz: Fundamental Frequency

EUT Test Condition		Measurement Detail	
Channel	Channel 48	Frequency Range	1 GHz ~ 40 GHz
Input Power	120 Vac, 60 Hz	Detector Function	Peak (PK) Average (AV)
Environmental Conditions	25 deg. C, 65 % RH	Tested By	Toby Tian

Antenna Polarity & Test Distance: Horizontal at 3 m										
Frequency (MHz)	Emission Level (dBuV/m)	Read Level (dBuV)	Limit (dBuV/m)	Margin (dB)	Antenna Factor (dB/m)	Cable Loss (dB)	Preamp Factor (dB)	Antenna Height (cm)	Table Angle (Degree)	Remark
5020	38.17	38.05	54	-15.83	31.21	6.15	37.24	200	70	Average
5020	60.87	60.75	74	-13.13	31.21	6.15	37.24	200	70	Peak
5240	88.84	88.52			31.39	6.25	37.32	200	70	Average
5240	98.58	98.26			31.39	6.25	37.32	200	70	Peak
5384	38.57	37.93	54	-15.43	31.51	6.31	37.18	200	70	Average
5384	60.85	60.21	74	-13.15	31.51	6.31	37.18	200	70	Peak
Antenna Polarity & Test Distance: Vertical at 3 m										
Frequency (MHz)	Emission Level (dBuV/m)	Read Level (dBuV)	Limit (dBuV/m)	Margin (dB)	Antenna Factor (dB/m)	Cable Loss (dB)	Preamp Factor (dB)	Antenna Height (cm)	Table Angle (Degree)	Remark
5144	38.43	38.23	54	-15.57	31.32	6.2	37.32	199	41	Average
5144	60.39	60.19	74	-13.61	31.32	6.2	37.32	199	41	Peak
5240	91.53	91.21			31.39	6.25	37.32	199	41	Average
5240	101.14	100.82			31.39	6.25	37.32	199	41	Peak
5406	38.73	38.07	54	-15.27	31.52	6.32	37.18	199	41	Average
5406	60.94	60.28	74	-13.06	31.52	6.32	37.18	199	41	Peak

Remarks:

- Emission Level = Read Level + Antenna Factor + Cable Loss - Preamp Factor  
Margin value = Emission level – Limit value
- 5240 MHz: Fundamental Frequency

EUT Test Condition		Measurement Detail	
Channel	Channel 52	Frequency Range	1 GHz ~ 40 GHz
Input Power	120 Vac, 60 Hz	Detector Function	Peak (PK) Average (AV)
Environmental Conditions	25 deg. C, 65 % RH	Tested By	Toby Tian

Antenna Polarity & Test Distance: Horizontal at 3 m										
Frequency (MHz)	Emission Level (dBuV/m)	Read Level (dBuV)	Limit (dBuV/m)	Margin (dB)	Antenna Factor (dB/m)	Cable Loss (dB)	Preamp Factor (dB)	Antenna Height (cm)	Table Angle (Degree)	Remark
5118	38.47	38.27	54	-15.53	31.29	6.19	37.28	199	58	Average
5118	60.05	59.85	74	-13.95	31.29	6.19	37.28	199	58	Peak
5260	89.03	88.64			31.41	6.25	37.27	199	58	Average
5260	99.8	99.41			31.41	6.25	37.27	199	58	Peak
5382	38.59	37.95	54	-15.41	31.51	6.31	37.18	199	58	Average
5382	60.78	60.14	74	-13.22	31.51	6.31	37.18	199	58	Peak
Antenna Polarity & Test Distance: Vertical at 3 m										
Frequency (MHz)	Emission Level (dBuV/m)	Read Level (dBuV)	Limit (dBuV/m)	Margin (dB)	Antenna Factor (dB/m)	Cable Loss (dB)	Preamp Factor (dB)	Antenna Height (cm)	Table Angle (Degree)	Remark
5138	38.73	38.52	54	-15.27	31.31	6.2	37.3	180	25	Average
5138	60.81	60.6	74	-13.19	31.31	6.2	37.3	180	25	Peak
5260	92.53	92.14			31.41	6.25	37.27	180	25	Average
5260	102.02	101.63			31.41	6.25	37.27	180	25	Peak
5380	38.61	37.97	54	-15.39	31.51	6.31	37.18	180	25	Average
5380	60.51	59.87	74	-13.49	31.51	6.31	37.18	180	25	Peak

Remarks:

- Emission Level = Read Level + Antenna Factor + Cable Loss - Preamp Factor  
Margin value = Emission level – Limit value
- 5260 MHz: Fundamental Frequency



EUT Test Condition		Measurement Detail	
Channel	Channel 60	Frequency Range	1 GHz ~ 40 GHz
Input Power	120 Vac, 60 Hz	Detector Function	Peak (PK) Average (AV)
Environmental Conditions	25 deg. C, 65 % RH	Tested By	Toby Tian

Antenna Polarity & Test Distance: Horizontal at 3 m										
Frequency (MHz)	Emission Level (dBuV/m)	Read Level (dBuV)	Limit (dBuV/m)	Margin (dB)	Antenna Factor (dB/m)	Cable Loss (dB)	Preamp Factor (dB)	Antenna Height (cm)	Table Angle (Degree)	Remark
5066	38.29	38.12	54	-15.71	31.25	6.17	37.25	203	57	Average
5066	60.53	60.36	74	-13.47	31.25	6.17	37.25	203	57	Peak
5300	89.13	88.61			31.44	6.27	37.19	203	57	Average
5300	99.71	99.19			31.44	6.27	37.19	203	57	Peak
5450	38.74	37.92	54	-15.26	31.56	6.34	37.08	203	57	Average
5450	60.88	60.06	74	-13.12	31.56	6.34	37.08	203	57	Peak
Antenna Polarity & Test Distance: Vertical at 3 m										
Frequency (MHz)	Emission Level (dBuV/m)	Read Level (dBuV)	Limit (dBuV/m)	Margin (dB)	Antenna Factor (dB/m)	Cable Loss (dB)	Preamp Factor (dB)	Antenna Height (cm)	Table Angle (Degree)	Remark
5118	38.46	38.26	54	-15.54	31.29	6.19	37.28	179	31	Average
5118	59.99	59.79	74	-14.01	31.29	6.19	37.28	179	31	Peak
5300	92.8	92.28			31.44	6.27	37.19	179	31	Average
5300	102	101.48			31.44	6.27	37.19	179	31	Peak
5374	38.83	38.21	54	-15.17	31.49	6.31	37.18	179	31	Average
5374	61.32	60.7	74	-12.68	31.49	6.31	37.18	179	31	Peak

Remarks:

- Emission Level = Read Level + Antenna Factor + Cable Loss - Preamp Factor  
Margin value = Emission level – Limit value
- 5300 MHz: Fundamental Frequency

EUT Test Condition		Measurement Detail	
Channel	Channel 64	Frequency Range	1 GHz ~ 40 GHz
Input Power	120 Vac, 60 Hz	Detector Function	Peak (PK) Average (AV)
Environmental Conditions	25 deg. C, 65 % RH	Tested By	Toby Tian

Antenna Polarity & Test Distance: Horizontal at 3 m										
Frequency (MHz)	Emission Level (dBuV/m)	Read Level (dBuV)	Limit (dBuV/m)	Margin (dB)	Antenna Factor (dB/m)	Cable Loss (dB)	Preamp Factor (dB)	Antenna Height (cm)	Table Angle (Degree)	Remark
5132	38.34	38.13	54	-15.66	31.31	6.2	37.3	189	48	Average
5132	60.28	60.07	74	-13.72	31.31	6.2	37.3	189	48	Peak
5320	89.22	88.67			31.45	6.29	37.19	189	48	Average
5320	99.73	99.18			31.45	6.29	37.19	189	48	Peak
5456	39.51	38.69	54	-14.49	31.56	6.34	37.08	189	48	Average
5456	60.58	59.76	74	-13.42	31.56	6.34	37.08	189	48	Peak
Antenna Polarity & Test Distance: Vertical at 3 m										
Frequency (MHz)	Emission Level (dBuV/m)	Read Level (dBuV)	Limit (dBuV/m)	Margin (dB)	Antenna Factor (dB/m)	Cable Loss (dB)	Preamp Factor (dB)	Antenna Height (cm)	Table Angle (Degree)	Remark
5136	38.62	38.41	54	-15.38	31.31	6.2	37.3	179	19	Average
5136	61.04	60.83	74	-12.96	31.31	6.2	37.3	179	19	Peak
5320	92.67	92.12			31.45	6.29	37.19	179	19	Average
5320	102	101.45			31.45	6.29	37.19	179	19	Peak
5456	40.13	39.31	54	-13.87	31.56	6.34	37.08	179	19	Average
5456	60.13	59.31	74	-13.87	31.56	6.34	37.08	179	19	Peak

Remarks:

- Emission Level = Read Level + Antenna Factor + Cable Loss - Preamp Factor  
Margin value = Emission level – Limit value
- 5320 MHz: Fundamental Frequency

EUT Test Condition		Measurement Detail	
Channel	Channel 100	Frequency Range	1 GHz ~ 40 GHz
Input Power	120 Vac, 60 Hz	Detector Function	Peak (PK) Average (AV)
Environmental Conditions	25 deg. C, 65 % RH	Tested By	Anson Lin

Antenna Polarity & Test Distance: Horizontal at 3 m										
Frequency (MHz)	Emission Level (dBuV/m)	Read Level (dBuV)	Limit (dBuV/m)	Margin (dB)	Antenna Factor (dB/m)	Cable Loss (dB)	Preamp Factor (dB)	Antenna Height (cm)	Table Angle (Degree)	Remark
5378	38.39	37.75	54	-15.61	31.51	6.31	37.18	120	57	Average
5378	60.83	60.19	74	-13.17	31.51	6.31	37.18	120	57	Peak
5470	59.28	58.45	68.2	-8.92	31.57	6.34	37.08	120	57	Peak
5500	83.01	82.08			31.6	6.36	37.03	120	57	Average
5500	93.64	92.71			31.6	6.36	37.03	120	57	Peak
5725	59.59	58.37	68.2	-8.61	31.96	6.69	37.43	120	57	Peak
Antenna Polarity & Test Distance: Vertical at 3 m										
Frequency (MHz)	Emission Level (dBuV/m)	Read Level (dBuV)	Limit (dBuV/m)	Margin (dB)	Antenna Factor (dB/m)	Cable Loss (dB)	Preamp Factor (dB)	Antenna Height (cm)	Table Angle (Degree)	Remark
5412	38.89	38.22	54	-15.11	31.53	6.32	37.18	220	20	Average
5412	60.48	59.81	74	-13.52	31.53	6.32	37.18	220	20	Peak
5470	59.52	58.69	68.2	-8.68	31.57	6.34	37.08	220	20	Peak
5500	89.97	89.04			31.6	6.36	37.03	220	20	Average
5500	99.17	98.24			31.6	6.36	37.03	220	20	Peak
5725	60.94	59.66	68.2	-7.26	31.96	6.75	37.43	220	20	Peak

Remarks:

- Emission Level = Read Level + Antenna Factor + Cable Loss - Preamp Factor  
Margin value = Emission level – Limit value
- 5500 MHz: Fundamental Frequency
- 5470 MHz & 5725 MHz: Out of Restricted Band

EUT Test Condition		Measurement Detail	
Channel	Channel 116	Frequency Range	1 GHz ~ 40 GHz
Input Power	120 Vac, 60 Hz	Detector Function	Peak (PK) Average (AV)
Environmental Conditions	25 deg. C, 65 % RH	Tested By	Gavin Wu

Antenna Polarity & Test Distance: Horizontal at 3 m										
Frequency (MHz)	Emission Level (dBuV/m)	Read Level (dBuV)	Limit (dBuV/m)	Margin (dB)	Antenna Factor (dB/m)	Cable Loss (dB)	Preamp Factor (dB)	Antenna Height (cm)	Table Angle (Degree)	Remark
5392	38.48	37.84	54	-15.52	31.51	6.31	37.18	124	55	Average
5392	60.7	60.06	74	-13.3	31.51	6.31	37.18	124	55	Peak
5470	57.77	56.94	68.2	-10.43	31.57	6.34	37.08	124	55	Peak
5580	83.05	82.01			31.71	6.49	37.16	124	55	Average
5580	93.79	92.75			31.71	6.49	37.16	124	55	Peak
5725	59.86	58.58	68.2	-8.34	31.96	6.75	37.43	124	55	Peak
Antenna Polarity & Test Distance: Vertical at 3 m										
Frequency (MHz)	Emission Level (dBuV/m)	Read Level (dBuV)	Limit (dBuV/m)	Margin (dB)	Antenna Factor (dB/m)	Cable Loss (dB)	Preamp Factor (dB)	Antenna Height (cm)	Table Angle (Degree)	Remark
5412	38.62	37.95	54	-15.38	31.53	6.32	37.18	232	20	Average
5412	60.09	59.42	74	-13.91	31.53	6.32	37.18	232	20	Peak
5470	58.14	57.31	68.2	-10.06	31.57	6.34	37.08	232	20	Peak
5580	89.6	88.56			31.71	6.49	37.16	232	20	Average
5580	99.75	98.71			31.71	6.49	37.16	232	20	Peak
5725	58.86	57.58	68.2	-9.34	31.96	6.75	37.43	232	20	Peak

Remarks:

- Emission Level = Read Level + Antenna Factor + Cable Loss - Preamp Factor  
Margin value = Emission level – Limit value
- 5580 MHz: Fundamental Frequency
- 5470 MHz & 5725 MHz: Out of Restricted Band

EUT Test Condition		Measurement Detail	
Channel	Channel 140	Frequency Range	1 GHz ~ 40 GHz
Input Power	120 Vac, 60 Hz	Detector Function	Peak (PK) Average (AV)
Environmental Conditions	25 deg. C, 65 % RH	Tested By	Gavin Wu

**Antenna Polarity & Test Distance: Horizontal at 3 m**

Frequency (MHz)	Emission Level (dBuV/m)	Read Level (dBuV)	Limit (dBuV/m)	Margin (dB)	Antenna Factor (dB/m)	Cable Loss (dB)	Preamp Factor (dB)	Antenna Height (cm)	Table Angle (Degree)	Remark
5436	38.51	37.77	54	-15.49	31.55	6.32	37.13	122	54	Average
5436	59.95	59.21	74	-14.05	31.55	6.32	37.13	122	54	Peak
5470	57.55	56.72	68.2	-10.65	31.57	6.34	37.08	122	54	Peak
5700	83.16	82.23			31.6	6.36	37.03	122	54	Average
5700	93.5	92.31			31.9	6.69	37.4	122	54	Peak
5725	60.36	59.08	68.2	-7.84	31.96	6.75	37.43	122	54	Peak

**Antenna Polarity & Test Distance: Vertical at 3 m**

Frequency (MHz)	Emission Level (dBuV/m)	Read Level (dBuV)	Limit (dBuV/m)	Margin (dB)	Antenna Factor (dB/m)	Cable Loss (dB)	Preamp Factor (dB)	Antenna Height (cm)	Table Angle (Degree)	Remark
5458	38.66	37.84	54	-15.34	31.56	6.34	37.08	243	13	Average
5458	60.47	59.65	74	-13.53	31.56	6.34	37.08	243	13	Peak
5470	60.97	60.14	68.2	-7.23	31.57	6.34	37.08	243	13	Peak
5700	89.1	87.91			31.9	6.69	37.4	243	13	Average
5700	99.19	98			31.9	6.69	37.4	243	13	Peak
5725	61.04	59.76	68.2	-7.16	31.96	6.75	37.43	243	13	Peak

Remarks:

- Emission Level = Read Level + Antenna Factor + Cable Loss - Preamp Factor  
Margin value = Emission level – Limit value
- 5700 MHz: Fundamental Frequency
- 5470 MHz & 5725 MHz: Out of Restricted Band

EUT Test Condition		Measurement Detail	
Channel	Channel 149	Frequency Range	1 GHz ~ 40 GHz
Input Power	120 Vac, 60 Hz	Detector Function	Peak (PK) Average (AV)
Environmental Conditions	25 deg. C, 65 % RH	Tested By	Gavin Wu

Antenna Polarity & Test Distance: Horizontal at 3 m										
Frequency (MHz)	Emission Level (dBuV/m)	Read Level (dBuV)	Limit (dBuV/m)	Margin (dB)	Antenna Factor (dB/m)	Cable Loss (dB)	Preamp Factor (dB)	Antenna Height (cm)	Table Angle (Degree)	Remark
*5714	60.06	58.87	68.2	-8.14	31.93	6.69	37.43	202	64	Peak
*5725	60.92	59.64	78.2	-17.28	31.96	6.75	37.43	202	64	Peak
5745	89.4	88.13			31.99	6.75	37.47	202	64	Average
5745	99.88	98.61			31.99	6.75	37.47	202	64	Peak
*5850	59.05	57.53	78.2	-19.15	32.15	6.88	37.51	202	64	Peak
*5861	60.29	58.66	68.2	-7.91	32.18	6.95	37.5	202	64	Peak

Antenna Polarity & Test Distance: Vertical at 3 m										
Frequency (MHz)	Emission Level (dBuV/m)	Read Level (dBuV)	Limit (dBuV/m)	Margin (dB)	Antenna Factor (dB/m)	Cable Loss (dB)	Preamp Factor (dB)	Antenna Height (cm)	Table Angle (Degree)	Remark
*5714	60.29	59.1	68.2	-7.91	31.93	6.69	37.43	191	14	Peak
*5725	61.98	60.7	78.2	-16.22	31.96	6.75	37.43	191	14	Peak
5745	87.22	85.95			31.99	6.75	37.47	191	14	Average
5745	97.79	96.52			31.99	6.75	37.47	191	14	Peak
*5850	61.72	60.2	78.2	-16.48	32.15	6.88	37.51	191	14	Peak
*5861	59.36	57.73	68.2	-8.84	32.18	6.95	37.5	191	14	Peak

Remarks:

- Emission Level = Read Level + Antenna Factor + Cable Loss - Preamp Factor  
Margin value = Emission level – Limit value
- 5745 MHz: Fundamental Frequency
- \*: Out of Restricted Band

EUT Test Condition		Measurement Detail	
Channel	Channel 157	Frequency Range	1 GHz ~ 40 GHz
Input Power	120 Vac, 60 Hz	Detector Function	Peak (PK) Average (AV)
Environmental Conditions	25 deg. C, 65 % RH	Tested By	Gavin Wu

Antenna Polarity & Test Distance: Horizontal at 3 m										
Frequency (MHz)	Emission Level (dBuV/m)	Read Level (dBuV)	Limit (dBuV/m)	Margin (dB)	Antenna Factor (dB/m)	Cable Loss (dB)	Preamp Factor (dB)	Antenna Height (cm)	Table Angle (Degree)	Remark
*5714	60.65	59.46	68.2	-7.55	31.93	6.69	37.43	202	62	Peak
*5725	61.23	59.95	78.2	-16.97	31.96	6.75	37.43	202	62	Peak
5785	89	87.68			32.04	6.82	37.54	202	62	Average
5785	99.42	98.1			32.04	6.82	37.54	202	62	Peak
*5850	60.34	58.82	78.2	-17.86	32.15	6.88	37.51	202	62	Peak
*5861	59.75	58.12	68.2	-8.45	32.18	6.95	37.5	202	62	Peak
Antenna Polarity & Test Distance: Vertical at 3 m										
Frequency (MHz)	Emission Level (dBuV/m)	Read Level (dBuV)	Limit (dBuV/m)	Margin (dB)	Antenna Factor (dB/m)	Cable Loss (dB)	Preamp Factor (dB)	Antenna Height (cm)	Table Angle (Degree)	Remark
*5714	58.4	57.21	68.2	-9.8	31.93	6.69	37.43	196	17	Peak
*5725	59.88	58.6	78.2	-18.32	31.96	6.75	37.43	196	17	Peak
5785	87.05	85.73			32.04	6.82	37.54	196	17	Average
5785	97.63	96.31			32.04	6.82	37.54	196	17	Peak
*5850	59.35	57.83	78.2	-18.85	32.15	6.88	37.51	196	17	Peak
*5861	59.09	57.46	68.2	-9.11	32.18	6.95	37.5	196	17	Peak

Remarks:

- Emission Level = Read Level + Antenna Factor + Cable Loss - Preamp Factor  
Margin value = Emission level – Limit value
- 5785 MHz: Fundamental Frequency
- \*: Out of Restricted Band

EUT Test Condition		Measurement Detail	
Channel	Channel 165	Frequency Range	1 GHz ~ 40 GHz
Input Power	120 Vac, 60 Hz	Detector Function	Peak (PK) Average (AV)
Environmental Conditions	25 deg. C, 65 % RH	Tested By	Gavin Wu

Antenna Polarity & Test Distance: Horizontal at 3 m										
Frequency (MHz)	Emission Level (dBuV/m)	Read Level (dBuV)	Limit (dBuV/m)	Margin (dB)	Antenna Factor (dB/m)	Cable Loss (dB)	Preamp Factor (dB)	Antenna Height (cm)	Table Angle (Degree)	Remark
*5714	59.37	58.18	68.2	-8.83	31.93	6.69	37.43	194	62	Peak
*5725	59.18	57.9	78.2	-19.02	31.96	6.75	37.43	194	62	Peak
5825	89.62	88.15			32.12	6.88	37.53	194	62	Average
5825	99.68	98.21			32.12	6.88	37.53	194	62	Peak
*5850	59.58	58.06	78.2	-18.62	32.15	6.88	37.51	194	62	Peak
*5861	60.15	58.52	68.2	-8.05	32.18	6.95	37.5	194	62	Peak
Antenna Polarity & Test Distance: Vertical at 3 m										
Frequency (MHz)	Emission Level (dBuV/m)	Read Level (dBuV)	Limit (dBuV/m)	Margin (dB)	Antenna Factor (dB/m)	Cable Loss (dB)	Preamp Factor (dB)	Antenna Height (cm)	Table Angle (Degree)	Remark
*5714	59.1	57.91	68.2	-9.1	31.93	6.69	37.43	194	29	Peak
*5725	60.23	58.95	78.2	-17.97	31.96	6.75	37.43	194	29	Peak
5825	87.55	86.08			32.12	6.88	37.53	194	29	Average
5825	97.42	95.95			32.12	6.88	37.53	194	29	Peak
*5850	59.27	57.75	78.2	-18.93	32.15	6.88	37.51	194	29	Peak
*5861	59.31	57.68	68.2	-8.89	32.18	6.95	37.5	194	29	Peak

Remarks:

- Emission Level = Read Level + Antenna Factor + Cable Loss - Preamp Factor  
Margin value = Emission level – Limit value
- 5825 MHz: Fundamental Frequency
- \*: Out of Restricted Band



802.11ac (VHT40)

EUT Test Condition		Measurement Detail	
Channel	Channel 38	Frequency Range	1 GHz ~ 40 GHz
Input Power	120 Vac, 60 Hz	Detector Function	Peak (PK) Average (AV)
Environmental Conditions	25 deg. C, 65 % RH	Tested By	Toby Tian

Antenna Polarity & Test Distance: Horizontal at 3 m										
Frequency (MHz)	Emission Level (dBuV/m)	Read Level (dBuV)	Limit (dBuV/m)	Margin (dB)	Antenna Factor (dB/m)	Cable Loss (dB)	Preamp Factor (dB)	Antenna Height (cm)	Table Angle (Degree)	Remark
5062	40.14	39.97	54	-13.86	31.25	6.17	37.25	193	66	Average
5062	60.26	60.09	74	-13.74	31.25	6.17	37.25	193	66	Peak
5190	84.39	84.16			31.35	6.22	37.34	193	66	Average
5190	94.02	93.79			31.35	6.22	37.34	193	66	Peak
5434	39.01	38.27	54	-14.99	31.55	6.32	37.13	193	66	Average
5434	60.93	60.19	74	-13.07	31.55	6.32	37.13	193	66	Peak

Antenna Polarity & Test Distance: Vertical at 3 m										
Frequency (MHz)	Emission Level (dBuV/m)	Read Level (dBuV)	Limit (dBuV/m)	Margin (dB)	Antenna Factor (dB/m)	Cable Loss (dB)	Preamp Factor (dB)	Antenna Height (cm)	Table Angle (Degree)	Remark
5122	41.91	41.73	54	-12.09	31.29	6.19	37.3	198	27	Average
5122	60.03	59.85	74	-13.97	31.29	6.19	37.3	198	27	Peak
5190	86.94	86.71			31.35	6.22	37.34	198	27	Average
5190	96.6	96.37			31.35	6.22	37.34	198	27	Peak
5426	39.04	38.32	54	-14.96	31.53	6.32	37.13	198	27	Average
5426	61.19	60.47	74	-12.81	31.53	6.32	37.13	198	27	Peak

Remarks:

- Emission Level = Read Level + Antenna Factor + Cable Loss - Preamp Factor  
Margin value = Emission level – Limit value
- 5190 MHz: Fundamental Frequency

EUT Test Condition		Measurement Detail	
Channel	Channel 46	Frequency Range	1 GHz ~ 40 GHz
Input Power	120 Vac, 60 Hz	Detector Function	Peak (PK) Average (AV)
Environmental Conditions	25 deg. C, 65 % RH	Tested By	Toby Tian

Antenna Polarity & Test Distance: Horizontal at 3 m										
Frequency (MHz)	Emission Level (dBuV/m)	Read Level (dBuV)	Limit (dBuV/m)	Margin (dB)	Antenna Factor (dB/m)	Cable Loss (dB)	Preamp Factor (dB)	Antenna Height (cm)	Table Angle (Degree)	Remark
5032	38.69	38.55	54	-15.31	31.23	6.15	37.24	193	53	Average
5032	60.39	60.25	74	-13.61	31.23	6.15	37.24	193	53	Peak
5230	84.61	84.3			31.39	6.24	37.32	193	53	Average
5230	94.15	93.84			31.39	6.24	37.32	193	53	Peak
5416	38.92	38.25	54	-15.08	31.53	6.32	37.18	193	53	Average
5416	60.26	59.59	74	-13.74	31.53	6.32	37.18	193	53	Peak

Antenna Polarity & Test Distance: Vertical at 3 m										
Frequency (MHz)	Emission Level (dBuV/m)	Read Level (dBuV)	Limit (dBuV/m)	Margin (dB)	Antenna Factor (dB/m)	Cable Loss (dB)	Preamp Factor (dB)	Antenna Height (cm)	Table Angle (Degree)	Remark
5056	38.96	38.79	54	-15.04	31.25	6.17	37.25	200	19	Average
5056	60.28	60.11	74	-13.72	31.25	6.17	37.25	200	19	Peak
5230	86.93	86.62			31.39	6.24	37.32	200	19	Average
5230	96.65	96.34			31.39	6.24	37.32	200	19	Peak
5370	38.93	38.31	54	-15.07	31.49	6.31	37.18	200	19	Average
5370	60.73	60.11	74	-13.27	31.49	6.31	37.18	200	19	Peak

Remarks:

- Emission Level = Read Level + Antenna Factor + Cable Loss - Preamp Factor  
Margin value = Emission level – Limit value
- 5230 MHz: Fundamental Frequency

EUT Test Condition		Measurement Detail	
Channel	Channel 54	Frequency Range	1 GHz ~ 40 GHz
Input Power	120 Vac, 60 Hz	Detector Function	Peak (PK) Average (AV)
Environmental Conditions	25 deg. C, 65 % RH	Tested By	Toby Tian

Antenna Polarity & Test Distance: Horizontal at 3 m										
Frequency (MHz)	Emission Level (dBuV/m)	Read Level (dBuV)	Limit (dBuV/m)	Margin (dB)	Antenna Factor (dB/m)	Cable Loss (dB)	Preamp Factor (dB)	Antenna Height (cm)	Table Angle (Degree)	Remark
5134	38.89	38.68	54	-15.11	31.31	6.2	37.3	201	52	Average
5134	60.88	60.67	74	-13.12	31.31	6.2	37.3	201	52	Peak
5270	84.57	84.18			31.41	6.25	37.27	201	52	Average
5270	94.47	94.08			31.41	6.25	37.27	201	52	Peak
5458	39.03	38.21	54	-14.97	31.56	6.34	37.08	201	52	Average
5458	60.04	59.22	74	-13.96	31.56	6.34	37.08	201	52	Peak
Antenna Polarity & Test Distance: Vertical at 3 m										
Frequency (MHz)	Emission Level (dBuV/m)	Read Level (dBuV)	Limit (dBuV/m)	Margin (dB)	Antenna Factor (dB/m)	Cable Loss (dB)	Preamp Factor (dB)	Antenna Height (cm)	Table Angle (Degree)	Remark
5104	39.04	38.85	54	-14.96	31.28	6.19	37.28	188	22	Average
5104	60.8	60.61	74	-13.2	31.28	6.19	37.28	188	22	Peak
5270	87.59	87.2			31.41	6.25	37.27	188	22	Average
5270	97.1	96.71			31.41	6.25	37.27	188	22	Peak
5456	39.1	38.28	54	-14.9	31.56	6.34	37.08	188	22	Average
5456	61.03	60.21	74	-12.97	31.56	6.34	37.08	188	22	Peak

Remarks:

- Emission Level = Read Level + Antenna Factor + Cable Loss - Preamp Factor  
Margin value = Emission level – Limit value
- 5270 MHz: Fundamental Frequency

EUT Test Condition		Measurement Detail	
Channel	Channel 62	Frequency Range	1 GHz ~ 40 GHz
Input Power	120 Vac, 60 Hz	Detector Function	Peak (PK) Average (AV)
Environmental Conditions	25 deg. C, 65 % RH	Tested By	Toby Tian

Antenna Polarity & Test Distance: Horizontal at 3 m										
Frequency (MHz)	Emission Level (dBuV/m)	Read Level (dBuV)	Limit (dBuV/m)	Margin (dB)	Antenna Factor (dB/m)	Cable Loss (dB)	Preamp Factor (dB)	Antenna Height (cm)	Table Angle (Degree)	Remark
5034	38.61	38.47	54	-15.39	31.23	6.15	37.24	201	60	Average
5034	60.53	60.39	74	-13.47	31.23	6.15	37.24	201	60	Peak
5310	84.54	84.01			31.45	6.27	37.19	201	60	Average
5310	94.37	93.84			31.45	6.27	37.19	201	60	Peak
5362	39.24	38.62	54	-14.76	31.49	6.31	37.18	201	60	Average
5362	61.01	60.39	74	-12.99	31.49	6.31	37.18	201	60	Peak
Antenna Polarity & Test Distance: Vertical at 3 m										
Frequency (MHz)	Emission Level (dBuV/m)	Read Level (dBuV)	Limit (dBuV/m)	Margin (dB)	Antenna Factor (dB/m)	Cable Loss (dB)	Preamp Factor (dB)	Antenna Height (cm)	Table Angle (Degree)	Remark
5038	38.89	38.74	54	-15.11	31.24	6.15	37.24	177	33	Average
5038	59.81	59.66	74	-14.19	31.24	6.15	37.24	177	33	Peak
5310	87.61	87.08			31.45	6.27	37.19	177	33	Average
5310	97.04	96.51			31.45	6.27	37.19	177	33	Peak
5390	40.14	39.5	54	-13.86	31.51	6.31	37.18	177	33	Average
5390	61.45	60.81	74	-12.55	31.51	6.31	37.18	177	33	Peak

Remarks:

- Emission Level = Read Level + Antenna Factor + Cable Loss - Preamp Factor  
Margin value = Emission level – Limit value
- 5310 MHz: Fundamental Frequency

EUT Test Condition		Measurement Detail	
Channel	Channel 102	Frequency Range	1 GHz ~ 40 GHz
Input Power	120 Vac, 60 Hz	Detector Function	Peak (PK) Average (AV)
Environmental Conditions	25 deg. C, 65 % RH	Tested By	Gavin Wu

Antenna Polarity & Test Distance: Horizontal at 3 m										
Frequency (MHz)	Emission Level (dBuV/m)	Read Level (dBuV)	Limit (dBuV/m)	Margin (dB)	Antenna Factor (dB/m)	Cable Loss (dB)	Preamp Factor (dB)	Antenna Height (cm)	Table Angle (Degree)	Remark
5436	40.98	40.24	54	-13.02	31.55	6.32	37.13	120	57	Average
5436	60.6	59.86	74	-13.4	31.55	6.32	37.13	120	57	Peak
5470	60.16	59.33	68.2	-8.04	31.57	6.34	37.08	120	57	Peak
5510	78.63	77.73			31.6	6.36	37.06	120	57	Average
5510	88.74	87.84			31.6	6.36	37.06	120	57	Peak
5725	60.29	59.01	68.2	-7.91	31.96	6.75	37.43	120	57	Peak
Antenna Polarity & Test Distance: Vertical at 3 m										
Frequency (MHz)	Emission Level (dBuV/m)	Read Level (dBuV)	Limit (dBuV/m)	Margin (dB)	Antenna Factor (dB/m)	Cable Loss (dB)	Preamp Factor (dB)	Antenna Height (cm)	Table Angle (Degree)	Remark
5414	39.59	38.92	54	-14.41	31.53	6.32	37.18	211	10	Average
5414	60.55	59.88	74	-13.45	31.53	6.32	37.18	211	10	Peak
5470	59.19	58.36	68.2	-9.01	31.57	6.34	37.08	211	10	Peak
5510	83.1	82.2			31.6	6.36	37.06	211	10	Average
5510	93.84	92.94			31.6	6.36	37.06	211	10	Peak
5725	61	59.72	68.2	-7.2	31.96	6.75	37.43	211	10	Peak

Remarks:

- Emission Level = Read Level + Antenna Factor + Cable Loss - Preamp Factor  
Margin value = Emission level – Limit value
- 5510 MHz: Fundamental Frequency
- 5470 MHz & 5725 MHz: Out of Restricted Band

EUT Test Condition		Measurement Detail	
Channel	Channel 110	Frequency Range	1 GHz ~ 40 GHz
Input Power	120 Vac, 60 Hz	Detector Function	Peak (PK) Average (AV)
Environmental Conditions	25 deg. C, 65 % RH	Tested By	Gavin Wu

Antenna Polarity & Test Distance: Horizontal at 3 m										
Frequency (MHz)	Emission Level (dBuV/m)	Read Level (dBuV)	Limit (dBuV/m)	Margin (dB)	Antenna Factor (dB/m)	Cable Loss (dB)	Preamp Factor (dB)	Antenna Height (cm)	Table Angle (Degree)	Remark
5416	38.81	38.14	54	-15.19	31.53	6.32	37.18	125	56	Average
5416	60.99	60.32	74	-13.01	31.53	6.32	37.18	125	56	Peak
5470	59.23	58.4	68.2	-8.97	31.57	6.34	37.08	125	56	Peak
5550	78.1	77.09			31.68	6.42	37.09	125	56	Average
5550	88.87	87.86			31.68	6.42	37.09	125	56	Peak
5725	60.05	58.77	68.2	-8.15	31.96	6.75	37.43	125	56	Peak
Antenna Polarity & Test Distance: Vertical at 3 m										
Frequency (MHz)	Emission Level (dBuV/m)	Read Level (dBuV)	Limit (dBuV/m)	Margin (dB)	Antenna Factor (dB/m)	Cable Loss (dB)	Preamp Factor (dB)	Antenna Height (cm)	Table Angle (Degree)	Remark
5452	38.98	38.16	54	-15.02	31.56	6.34	37.08	224	7	Average
5452	60.14	59.32	74	-13.86	31.56	6.34	37.08	224	7	Peak
5470	58.8	57.97	68.2	-9.4	31.57	6.34	37.08	224	7	Peak
5550	83.13	82.12			31.68	6.42	37.09	224	7	Average
5550	93.1	92.09			31.68	6.42	37.09	224	7	Peak
5725	60.84	59.56	68.2	-7.36	31.96	6.75	37.43	224	7	Peak

Remarks:

- Emission Level = Read Level + Antenna Factor + Cable Loss - Preamp Factor  
Margin value = Emission level – Limit value
- 5550 MHz: Fundamental Frequency
- 5470 MHz & 5725 MHz: Out of Restricted Band

EUT Test Condition		Measurement Detail	
Channel	Channel 134	Frequency Range	1 GHz ~ 40 GHz
Input Power	120 Vac, 60 Hz	Detector Function	Peak (PK) Average (AV)
Environmental Conditions	25 deg. C, 65 % RH	Tested By	Gavin Wu

Antenna Polarity & Test Distance: Horizontal at 3 m										
Frequency (MHz)	Emission Level (dBuV/m)	Read Level (dBuV)	Limit (dBuV/m)	Margin (dB)	Antenna Factor (dB/m)	Cable Loss (dB)	Preamp Factor (dB)	Antenna Height (cm)	Table Angle (Degree)	Remark
5364	38.91	38.29	54	-15.09	31.49	6.31	37.18	123	56	Average
5364	61.1	60.48	74	-12.9	31.49	6.31	37.18	123	56	Peak
5470	59.2	58.37	68.2	-9	31.57	6.34	37.08	123	56	Peak
5670	78.71	77.55			31.88	6.62	37.34	123	56	Average
5670	88.52	87.36			31.88	6.62	37.34	123	56	Peak
5725	59.83	58.55	68.2	-8.37	31.96	6.75	37.43	123	56	Peak
Antenna Polarity & Test Distance: Vertical at 3 m										
Frequency (MHz)	Emission Level (dBuV/m)	Read Level (dBuV)	Limit (dBuV/m)	Margin (dB)	Antenna Factor (dB/m)	Cable Loss (dB)	Preamp Factor (dB)	Antenna Height (cm)	Table Angle (Degree)	Remark
5404	39.03	38.37	54	-14.97	31.52	6.32	37.18	227	17	Average
5404	59.84	59.18	74	-14.16	31.52	6.32	37.18	227	17	Peak
5470	58.62	57.79	68.2	-9.58	31.57	6.34	37.08	227	17	Peak
5670	83.64	82.48			31.88	6.62	37.34	227	17	Average
5670	93.74	92.58			31.88	6.62	37.34	227	17	Peak
5725	59.95	58.67	68.2	-8.25	31.96	6.75	37.43	227	17	Peak

Remarks:

- Emission Level = Read Level + Antenna Factor + Cable Loss - Preamp Factor  
Margin value = Emission level – Limit value
- 5670 MHz: Fundamental Frequency
- 5470 MHz & 5725 MHz: Out of Restricted Band

EUT Test Condition		Measurement Detail	
Channel	Channel 151	Frequency Range	1 GHz ~ 40 GHz
Input Power	120 Vac, 60 Hz	Detector Function	Peak (PK) Average (AV)
Environmental Conditions	25 deg. C, 65 % RH	Tested By	Gavin Wu

Antenna Polarity & Test Distance: Horizontal at 3 m										
Frequency (MHz)	Emission Level (dBuV/m)	Read Level (dBuV)	Limit (dBuV/m)	Margin (dB)	Antenna Factor (dB/m)	Cable Loss (dB)	Preamp Factor (dB)	Antenna Height (cm)	Table Angle (Degree)	Remark
*5714	59.97	58.78	68.2	-8.23	31.93	6.69	37.43	191	65	Peak
*5725	60.02	58.74	78.2	-18.18	31.96	6.75	37.43	191	65	Peak
5755	83.4	82.11			32.01	6.75	37.47	191	65	Average
5755	93.6	92.31			32.01	6.75	37.47	191	65	Peak
*5850	59.79	58.27	78.2	-18.41	32.15	6.88	37.51	191	65	Peak
*5861	59.35	57.72	68.2	-8.85	32.18	6.95	37.5	191	65	Peak

Antenna Polarity & Test Distance: Vertical at 3 m										
Frequency (MHz)	Emission Level (dBuV/m)	Read Level (dBuV)	Limit (dBuV/m)	Margin (dB)	Antenna Factor (dB/m)	Cable Loss (dB)	Preamp Factor (dB)	Antenna Height (cm)	Table Angle (Degree)	Remark
*5714	59.42	58.23	68.2	-8.78	31.93	6.69	37.43	181	29	Peak
*5725	60.05	58.77	78.2	-18.15	31.96	6.75	37.43	181	29	Peak
5755	81.08	79.79			32.01	6.75	37.47	181	29	Average
5755	91.62	90.33			32.01	6.75	37.47	181	29	Peak
*5850	58.24	56.72	78.2	-19.96	32.15	6.88	37.51	181	29	Peak
*5861	59.08	57.45	68.2	-9.12	32.18	6.95	37.5	181	29	Peak

Remarks:

- Emission Level = Read Level + Antenna Factor + Cable Loss - Preamp Factor  
Margin value = Emission level – Limit value
- 5755 MHz: Fundamental Frequency
- \*: Out of Restricted Band



EUT Test Condition		Measurement Detail	
Channel	Channel 159	Frequency Range	1 GHz ~ 40 GHz
Input Power	120 Vac, 60 Hz	Detector Function	Peak (PK) Average (AV)
Environmental Conditions	25 deg. C, 65 % RH	Tested By	Gavin Wu

Antenna Polarity & Test Distance: Horizontal at 3 m										
Frequency (MHz)	Emission Level (dBuV/m)	Read Level (dBuV)	Limit (dBuV/m)	Margin (dB)	Antenna Factor (dB/m)	Cable Loss (dB)	Preamp Factor (dB)	Antenna Height (cm)	Table Angle (Degree)	Remark
*5714	60	58.81	68.2	-8.2	31.93	6.69	37.43	199	62	Peak
*5725	60.11	58.83	78.2	-18.09	31.96	6.75	37.43	199	62	Peak
5795	83.94	82.59			32.07	6.82	37.54	199	62	Average
5795	93.42	92.07			32.07	6.82	37.54	199	62	Peak
*5850	60.06	58.54	78.2	-18.14	32.15	6.88	37.51	199	62	Peak
*5861	59.45	57.82	68.2	-8.75	32.18	6.95	37.5	199	62	Peak
Antenna Polarity & Test Distance: Vertical at 3 m										
Frequency (MHz)	Emission Level (dBuV/m)	Read Level (dBuV)	Limit (dBuV/m)	Margin (dB)	Antenna Factor (dB/m)	Cable Loss (dB)	Preamp Factor (dB)	Antenna Height (cm)	Table Angle (Degree)	Remark
*5714	59.39	58.2	68.2	-8.81	31.93	6.69	37.43	179	28	Peak
*5725	60.39	59.11	78.2	-17.81	31.96	6.75	37.43	179	28	Peak
5795	81.21	79.86			32.07	6.82	37.54	179	28	Average
5795	91.6	90.25			32.07	6.82	37.54	179	28	Peak
*5850	59.39	57.87	78.2	-18.81	32.15	6.88	37.51	179	28	Peak
*5861	60.04	58.41	68.2	-8.16	32.18	6.95	37.5	179	28	Peak

Remarks:

- Emission Level = Read Level + Antenna Factor + Cable Loss - Preamp Factor  
Margin value = Emission level – Limit value
- 5795 MHz: Fundamental Frequency
- \*: Out of Restricted Band

### 802.11ac (VHT80)

EUT Test Condition		Measurement Detail	
Channel	Channel 42	Frequency Range	1 GHz ~ 40 GHz
Input Power	120 Vac, 60 Hz	Detector Function	Peak (PK) Average (AV)
Environmental Conditions	25 deg. C, 65 % RH	Tested By	Toby Tian

#### Antenna Polarity & Test Distance: Horizontal at 3 m

Frequency (MHz)	Emission Level (dBuV/m)	Read Level (dBuV)	Limit (dBuV/m)	Margin (dB)	Antenna Factor (dB/m)	Cable Loss (dB)	Preamp Factor (dB)	Antenna Height (cm)	Table Angle (Degree)	Remark
5140	40.14	39.92	54	-13.86	31.32	6.2	37.3	200	67	Average
5140	60.4	60.18	74	-13.6	31.32	6.2	37.3	200	67	Peak
5210	78.8	78.55			31.37	6.24	37.36	200	67	Average
5210	89.17	88.92			31.37	6.24	37.36	200	67	Peak
5404	39.23	38.57	54	-14.77	31.52	6.32	37.18	200	67	Average
5404	60.3	59.64	74	-13.7	31.52	6.32	37.18	200	67	Peak

#### Antenna Polarity & Test Distance: Vertical at 3 m

Frequency (MHz)	Emission Level (dBuV/m)	Read Level (dBuV)	Limit (dBuV/m)	Margin (dB)	Antenna Factor (dB/m)	Cable Loss (dB)	Preamp Factor (dB)	Antenna Height (cm)	Table Angle (Degree)	Remark
5122	41.84	41.66	54	-12.16	31.29	6.19	37.3	192	43	Average
5122	61.21	61.03	74	-12.79	31.29	6.19	37.3	192	43	Peak
5210	80.96	80.71			31.37	6.24	37.36	192	43	Average
5210	91.81	91.56			31.37	6.24	37.36	192	43	Peak
5350	39.17	38.58	54	-14.83	31.48	6.29	37.18	192	43	Average
5350	60.13	59.54	74	-13.87	31.48	6.29	37.18	192	43	Peak

Remarks:

- Emission Level = Read Level + Antenna Factor + Cable Loss - Preamp Factor  
Margin value = Emission level – Limit value
- 5210 MHz: Fundamental Frequency

EUT Test Condition		Measurement Detail	
Channel	Channel 58	Frequency Range	1 GHz ~ 40 GHz
Input Power	120 Vac, 60 Hz	Detector Function	Peak (PK) Average (AV)
Environmental Conditions	25 deg. C, 65 % RH	Tested By	Toby Tian

Antenna Polarity & Test Distance: Horizontal at 3 m										
Frequency (MHz)	Emission Level (dBuV/m)	Read Level (dBuV)	Limit (dBuV/m)	Margin (dB)	Antenna Factor (dB/m)	Cable Loss (dB)	Preamp Factor (dB)	Antenna Height (cm)	Table Angle (Degree)	Remark
5102	38.98	38.79	54	-15.02	31.28	6.19	37.28	198	44	Average
5102	59.96	59.77	74	-14.04	31.28	6.19	37.28	198	44	Peak
5290	79.84	79.37			31.43	6.27	37.23	198	44	Average
5290	89.76	89.29			31.43	6.27	37.23	198	44	Peak
5386	41.06	40.42	54	-12.94	31.51	6.31	37.18	198	44	Average
5386	60.95	60.31	74	-13.05	31.51	6.31	37.18	198	44	Peak
Antenna Polarity & Test Distance: Vertical at 3 m										
Frequency (MHz)	Emission Level (dBuV/m)	Read Level (dBuV)	Limit (dBuV/m)	Margin (dB)	Antenna Factor (dB/m)	Cable Loss (dB)	Preamp Factor (dB)	Antenna Height (cm)	Table Angle (Degree)	Remark
5134	39.14	38.93	54	-14.86	31.31	6.2	37.3	181	26	Average
5134	60.45	60.24	74	-13.55	31.31	6.2	37.3	181	26	Peak
5290	82.38	81.91			31.43	6.27	37.23	181	26	Average
5290	92.15	91.68			31.43	6.27	37.23	181	26	Peak
5358	43	42.39	54	-11	31.48	6.31	37.18	181	26	Average
5358	60.95	60.34	74	-13.05	31.48	6.31	37.18	181	26	Peak

Remarks:

- Emission Level = Read Level + Antenna Factor + Cable Loss - Preamp Factor  
Margin value = Emission level – Limit value
- 5290 MHz: Fundamental Frequency

EUT Test Condition		Measurement Detail	
Channel	Channel 106	Frequency Range	1 GHz ~ 40 GHz
Input Power	120 Vac, 60 Hz	Detector Function	Peak (PK) Average (AV)
Environmental Conditions	25 deg. C, 65 % RH	Tested By	Gavin Wu

Antenna Polarity & Test Distance: Horizontal at 3 m										
Frequency (MHz)	Emission Level (dBuV/m)	Read Level (dBuV)	Limit (dBuV/m)	Margin (dB)	Antenna Factor (dB/m)	Cable Loss (dB)	Preamp Factor (dB)	Antenna Height (cm)	Table Angle (Degree)	Remark
5350	38.98	38.39	54	-15.02	31.48	6.29	37.18	126	57	Average
5350	61.1	60.51	74	-12.9	31.48	6.29	37.18	126	57	Peak
5470	59.99	59.16	68.2	-8.21	31.57	6.34	37.08	126	57	Peak
5530	73.34	72.38			31.63	6.42	37.09	126	57	Average
5530	83.6	82.64			31.63	6.42	37.09	126	57	Peak
5725	62.26	60.98	68.2	-5.94	31.96	6.75	37.43	126	57	Peak
Antenna Polarity & Test Distance: Vertical at 3 m										
Frequency (MHz)	Emission Level (dBuV/m)	Read Level (dBuV)	Limit (dBuV/m)	Margin (dB)	Antenna Factor (dB/m)	Cable Loss (dB)	Preamp Factor (dB)	Antenna Height (cm)	Table Angle (Degree)	Remark
5440	39.75	38.99	54	-14.25	31.55	6.34	37.13	225	19	Average
5440	60.86	60.1	74	-13.14	31.55	6.34	37.13	225	19	Peak
5470	57.23	56.4	68.2	-10.97	31.57	6.34	37.08	225	19	Peak
5530	78.51	77.55			31.63	6.42	37.09	225	19	Average
5530	88.33	87.37			31.63	6.42	37.09	225	19	Peak
5725	63.58	62.3	68.2	-4.62	31.96	6.75	37.43	225	19	Peak

Remarks:

- Emission Level = Read Level + Antenna Factor + Cable Loss - Preamp Factor  
Margin value = Emission level – Limit value
- 5530 MHz: Fundamental Frequency
- 5470 MHz & 5725 MHz: Out of Restricted Band

EUT Test Condition		Measurement Detail	
Channel	Channel 122	Frequency Range	1 GHz ~ 40 GHz
Input Power	120 Vac, 60 Hz	Detector Function	Peak (PK) Average (AV)
Environmental Conditions	25 deg. C, 65 % RH	Tested By	Gavin Wu

Antenna Polarity & Test Distance: Horizontal at 3 m										
Frequency (MHz)	Emission Level (dBuV/m)	Read Level (dBuV)	Limit (dBuV/m)	Margin (dB)	Antenna Factor (dB/m)	Cable Loss (dB)	Preamp Factor (dB)	Antenna Height (cm)	Table Angle (Degree)	Remark
5358	38.75	38.14	54	-15.25	31.48	6.31	37.18	108	17	Average
5358	61.28	60.67	74	-12.72	31.48	6.31	37.18	108	17	Peak
5470	60.13	59.3	68.2	-8.07	31.57	6.34	37.08	108	17	Peak
5610	71.14	70.03			31.77	6.56	37.22	108	17	Average
5610	84.65	83.54			31.77	6.56	37.22	108	17	Peak
5725	60.57	59.35	68.2	-7.63	31.96	6.69	37.43	108	17	Peak
Antenna Polarity & Test Distance: Vertical at 3 m										
Frequency (MHz)	Emission Level (dBuV/m)	Read Level (dBuV)	Limit (dBuV/m)	Margin (dB)	Antenna Factor (dB/m)	Cable Loss (dB)	Preamp Factor (dB)	Antenna Height (cm)	Table Angle (Degree)	Remark
5408	38.82	38.16	54	-15.18	31.52	6.32	37.18	191	54	Average
5408	60.4	59.74	74	-13.6	31.52	6.32	37.18	191	54	Peak
5470	59.18	58.35	68.2	-9.02	31.57	6.34	37.08	191	54	Peak
5610	74.88	73.77			31.77	6.56	37.22	191	54	Average
5610	89.77	88.66			31.77	6.56	37.22	191	54	Peak
5725	60.8	59.58	68.2	-7.4	31.96	6.69	37.43	191	54	Peak

Remarks:

- Emission Level = Read Level + Antenna Factor + Cable Loss - Preamp Factor  
Margin value = Emission level – Limit value
- 5610 MHz: Fundamental Frequency
- 5470 MHz & 5725 MHz: Out of Restricted Band

EUT Test Condition		Measurement Detail	
Channel	Channel 155	Frequency Range	1 GHz ~ 40 GHz
Input Power	120 Vac, 60 Hz	Detector Function	Peak (PK) Average (AV)
Environmental Conditions	25 deg. C, 65 % RH	Tested By	Gavin Wu

Antenna Polarity & Test Distance: Horizontal at 3 m										
Frequency (MHz)	Emission Level (dBuV/m)	Read Level (dBuV)	Limit (dBuV/m)	Margin (dB)	Antenna Factor (dB/m)	Cable Loss (dB)	Preamp Factor (dB)	Antenna Height (cm)	Table Angle (Degree)	Remark
*5714	59.71	58.52	68.2	-8.49	31.93	6.69	37.43	200	63	Peak
*5725	61.89	60.61	78.2	-16.31	31.96	6.75	37.43	200	63	Peak
5775	79.88	78.52			32.04	6.82	37.5	200	63	Average
5775	89.09	87.73			32.04	6.82	37.5	200	63	Peak
*5850	61.6	60.08	78.2	-16.6	32.15	6.88	37.51	200	63	Peak
*5861	61.52	59.89	68.2	-6.68	32.18	6.95	37.5	200	63	Peak
Antenna Polarity & Test Distance: Vertical at 3 m										
Frequency (MHz)	Emission Level (dBuV/m)	Read Level (dBuV)	Limit (dBuV/m)	Margin (dB)	Antenna Factor (dB/m)	Cable Loss (dB)	Preamp Factor (dB)	Antenna Height (cm)	Table Angle (Degree)	Remark
*5714	59.64	58.45	68.2	-8.56	31.93	6.69	37.43	178	30	Peak
*5725	58.7	57.42	78.2	-19.5	31.96	6.75	37.43	178	30	Peak
5775	77.32	75.96			32.04	6.82	37.5	178	30	Average
5775	87.99	86.63			32.04	6.82	37.5	178	30	Peak
*5850	59.87	58.35	78.2	-18.33	32.15	6.88	37.51	178	30	Peak
*5861	60.48	58.85	68.2	-7.72	32.18	6.95	37.5	178	30	Peak

Remarks:

- Emission Level = Read Level + Antenna Factor + Cable Loss - Preamp Factor  
Margin value = Emission level – Limit value
- 5775 MHz: Fundamental Frequency
- \*: Out of Restricted Band

**Mode B**

**802.11n (HT20)**

EUT Test Condition		Measurement Detail	
Channel	Channel 36	Frequency Range	1 GHz ~ 40 GHz
Input Power	120 Vac, 60 Hz	Detector Function	Peak (PK) Average (AV)
Environmental Conditions	25 deg. C, 65 % RH	Tested By	Toby Tian

Antenna Polarity & Test Distance: Horizontal at 3 m										
Frequency (MHz)	Emission Level (dBuV/m)	Read Level (dBuV)	Limit (dBuV/m)	Margin (dB)	Antenna Factor (dB/m)	Cable Loss (dB)	Preamp Factor (dB)	Antenna Height (cm)	Table Angle (Degree)	Remark
5034	39.33	39.19	54	-14.67	31.23	6.15	37.24	197	56	Average
5034	61.05	60.91	74	-12.95	31.23	6.15	37.24	197	56	Peak
5180	90.57	90.34			31.35	6.22	37.34	197	56	Average
5180	100.93	100.7			31.35	6.22	37.34	197	56	Peak
5450	38.57	37.75	54	-15.43	31.56	6.34	37.08	197	56	Average
5450	60.56	59.74	74	-13.44	31.56	6.34	37.08	197	56	Peak

Antenna Polarity & Test Distance: Vertical at 3 m										
Frequency (MHz)	Emission Level (dBuV/m)	Read Level (dBuV)	Limit (dBuV/m)	Margin (dB)	Antenna Factor (dB/m)	Cable Loss (dB)	Preamp Factor (dB)	Antenna Height (cm)	Table Angle (Degree)	Remark
5052	41.63	41.47	54	-12.37	31.24	6.17	37.25	190	27	Average
5052	59.81	59.65	74	-14.19	31.24	6.17	37.25	190	27	Peak
5180	93.46	93.23			31.35	6.22	37.34	190	27	Average
5180	103.62	103.39			31.35	6.22	37.34	190	27	Peak
5410	38.74	38.08	54	-15.26	31.52	6.32	37.18	190	27	Average
5410	60.46	59.8	74	-13.54	31.52	6.32	37.18	190	27	Peak

Remarks:

- Emission Level = Read Level + Antenna Factor + Cable Loss - Preamp Factor  
Margin value = Emission level – Limit value
- 5180 MHz: Fundamental Frequency

EUT Test Condition		Measurement Detail	
Channel	Channel 44	Frequency Range	1 GHz ~ 40 GHz
Input Power	120 Vac, 60 Hz	Detector Function	Peak (PK) Average (AV)
Environmental Conditions	25 deg. C, 65 % RH	Tested By	Toby Tian

Antenna Polarity & Test Distance: Horizontal at 3 m										
Frequency (MHz)	Emission Level (dBuV/m)	Read Level (dBuV)	Limit (dBuV/m)	Margin (dB)	Antenna Factor (dB/m)	Cable Loss (dB)	Preamp Factor (dB)	Antenna Height (cm)	Table Angle (Degree)	Remark
5032	38.36	38.22	54	-15.64	31.23	6.15	37.24	199	54	Average
5032	60.07	59.93	74	-13.93	31.23	6.15	37.24	199	54	Peak
5220	91.92	91.67			31.37	6.24	37.36	199	54	Average
5220	101.1	100.85			31.37	6.24	37.36	199	54	Peak
5434	38.6	37.86	54	-15.4	31.55	6.32	37.13	199	54	Average
5434	60.34	59.6	74	-13.66	31.55	6.32	37.13	199	54	Peak
Antenna Polarity & Test Distance: Vertical at 3 m										
Frequency (MHz)	Emission Level (dBuV/m)	Read Level (dBuV)	Limit (dBuV/m)	Margin (dB)	Antenna Factor (dB/m)	Cable Loss (dB)	Preamp Factor (dB)	Antenna Height (cm)	Table Angle (Degree)	Remark
5118	38.91	38.71	54	-15.09	31.29	6.19	37.28	199	28	Average
5118	59.77	59.57	74	-14.23	31.29	6.19	37.28	199	28	Peak
5220	93.53	93.28			31.37	6.24	37.36	199	28	Average
5220	103.85	103.6			31.37	6.24	37.36	199	28	Peak
5432	38.86	38.12	54	-15.14	31.55	6.32	37.13	199	28	Average
5432	60.45	59.71	74	-13.55	31.55	6.32	37.13	199	28	Peak

Remarks:

- Emission Level = Read Level + Antenna Factor + Cable Loss - Preamp Factor  
Margin value = Emission level – Limit value
- 5220 MHz: Fundamental Frequency



EUT Test Condition		Measurement Detail	
Channel	Channel 48	Frequency Range	1 GHz ~ 40 GHz
Input Power	120 Vac, 60 Hz	Detector Function	Peak (PK) Average (AV)
Environmental Conditions	25 deg. C, 65 % RH	Tested By	Toby Tian

Antenna Polarity & Test Distance: Horizontal at 3 m										
Frequency (MHz)	Emission Level (dBuV/m)	Read Level (dBuV)	Limit (dBuV/m)	Margin (dB)	Antenna Factor (dB/m)	Cable Loss (dB)	Preamp Factor (dB)	Antenna Height (cm)	Table Angle (Degree)	Remark
5066	38.36	38.19	54	-15.64	31.25	6.17	37.25	198	50	Average
5066	60.74	60.57	74	-13.26	31.25	6.17	37.25	198	50	Peak
5240	91.95	91.63			31.39	6.25	37.32	198	50	Average
5240	101.13	100.81			31.39	6.25	37.32	198	50	Peak
5366	38.69	38.07	54	-15.31	31.49	6.31	37.18	198	50	Average
5366	60.73	60.11	74	-13.27	31.49	6.31	37.18	198	50	Peak

Antenna Polarity & Test Distance: Vertical at 3 m										
Frequency (MHz)	Emission Level (dBuV/m)	Read Level (dBuV)	Limit (dBuV/m)	Margin (dB)	Antenna Factor (dB/m)	Cable Loss (dB)	Preamp Factor (dB)	Antenna Height (cm)	Table Angle (Degree)	Remark
5012	38.7	38.59	54	-15.3	31.21	6.13	37.23	199	24	Average
5012	60.55	60.44	74	-13.45	31.21	6.13	37.23	199	24	Peak
5240	93.56	93.24			31.39	6.25	37.32	199	24	Average
5240	103.87	103.55			31.39	6.25	37.32	199	24	Peak
5352	38.8	38.21	54	-15.2	31.48	6.29	37.18	199	24	Average
5352	61.15	60.56	74	-12.85	31.48	6.29	37.18	199	24	Peak

Remarks:

- Emission Level = Read Level + Antenna Factor + Cable Loss - Preamp Factor  
Margin value = Emission level – Limit value
- 5240 MHz: Fundamental Frequency

EUT Test Condition		Measurement Detail	
Channel	Channel 52	Frequency Range	1 GHz ~ 40 GHz
Input Power	120 Vac, 60 Hz	Detector Function	Peak (PK) Average (AV)
Environmental Conditions	25 deg. C, 65 % RH	Tested By	Gavin Wu

Antenna Polarity & Test Distance: Horizontal at 3 m										
Frequency (MHz)	Emission Level (dBuV/m)	Read Level (dBuV)	Limit (dBuV/m)	Margin (dB)	Antenna Factor (dB/m)	Cable Loss (dB)	Preamp Factor (dB)	Antenna Height (cm)	Table Angle (Degree)	Remark
5048	40.83	40.69	54	-13.17	31.24	6.15	37.25	100	340	Average
5048	60.88	60.74	74	-13.12	31.24	6.15	37.25	100	340	Peak
5260	88.05	87.66			31.41	6.25	37.27	100	340	Average
5260	98.71	98.32			31.41	6.25	37.27	100	340	Peak
5416	40.41	39.74	54	-13.59	31.53	6.32	37.18	100	340	Average
5416	60.62	59.95	74	-13.38	31.53	6.32	37.18	100	340	Peak
Antenna Polarity & Test Distance: Vertical at 3 m										
Frequency (MHz)	Emission Level (dBuV/m)	Read Level (dBuV)	Limit (dBuV/m)	Margin (dB)	Antenna Factor (dB/m)	Cable Loss (dB)	Preamp Factor (dB)	Antenna Height (cm)	Table Angle (Degree)	Remark
5072	40.95	40.78	54	-13.05	31.27	6.17	37.27	202	17	Average
5072	60.65	60.48	74	-13.35	31.27	6.17	37.27	202	17	Peak
5260	94.97	94.58			31.41	6.25	37.27	202	17	Average
5260	104.21	103.82			31.41	6.25	37.27	202	17	Peak
5440	40.69	39.93	54	-13.31	31.55	6.34	37.13	202	17	Average
5440	60.81	60.05	74	-13.19	31.55	6.34	37.13	202	17	Peak

Remarks:

- Emission Level = Read Level + Antenna Factor + Cable Loss - Preamp Factor  
Margin value = Emission level – Limit value
- 5260 MHz: Fundamental Frequency

EUT Test Condition		Measurement Detail	
Channel	Channel 60	Frequency Range	1 GHz ~ 40 GHz
Input Power	120 Vac, 60 Hz	Detector Function	Peak (PK) Average (AV)
Environmental Conditions	25 deg. C, 65 % RH	Tested By	Gavin Wu

Antenna Polarity & Test Distance: Horizontal at 3 m										
Frequency (MHz)	Emission Level (dBuV/m)	Read Level (dBuV)	Limit (dBuV/m)	Margin (dB)	Antenna Factor (dB/m)	Cable Loss (dB)	Preamp Factor (dB)	Antenna Height (cm)	Table Angle (Degree)	Remark
5134	40.31	40.1	54	-13.69	31.31	6.2	37.3	100	59	Average
5134	60.78	60.57	74	-13.22	31.31	6.2	37.3	100	59	Peak
5300	87.74	87.22			31.44	6.27	37.19	100	59	Average
5300	97.05	96.53			31.44	6.27	37.19	100	59	Peak
5456	40.58	39.76	54	-13.42	31.56	6.34	37.08	100	59	Average
5456	60.5	59.68	74	-13.5	31.56	6.34	37.08	100	59	Peak

Antenna Polarity & Test Distance: Vertical at 3 m										
Frequency (MHz)	Emission Level (dBuV/m)	Read Level (dBuV)	Limit (dBuV/m)	Margin (dB)	Antenna Factor (dB/m)	Cable Loss (dB)	Preamp Factor (dB)	Antenna Height (cm)	Table Angle (Degree)	Remark
5100	40.17	39.98	54	-13.83	31.28	6.19	37.28	200	30	Average
5100	60.65	60.46	74	-13.35	31.28	6.19	37.28	200	30	Peak
5300	94.02	93.5			31.44	6.27	37.19	200	30	Average
5300	104.52	104			31.44	6.27	37.19	200	30	Peak
5444	41.29	40.53	54	-12.71	31.55	6.34	37.13	200	30	Average
5444	61.22	60.46	74	-12.78	31.55	6.34	37.13	200	30	Peak

Remarks:

- Emission Level = Read Level + Antenna Factor + Cable Loss - Preamp Factor  
Margin value = Emission level – Limit value
- 5300 MHz: Fundamental Frequency

EUT Test Condition		Measurement Detail	
Channel	Channel 64	Frequency Range	1 GHz ~ 40 GHz
Input Power	120 Vac, 60 Hz	Detector Function	Peak (PK) Average (AV)
Environmental Conditions	25 deg. C, 65 % RH	Tested By	Gavin Wu

Antenna Polarity & Test Distance: Horizontal at 3 m										
Frequency (MHz)	Emission Level (dBuV/m)	Read Level (dBuV)	Limit (dBuV/m)	Margin (dB)	Antenna Factor (dB/m)	Cable Loss (dB)	Preamp Factor (dB)	Antenna Height (cm)	Table Angle (Degree)	Remark
5138	40.43	40.22	54	-13.57	31.31	6.2	37.3	100	340	Average
5138	60.56	60.35	74	-13.44	31.31	6.2	37.3	100	340	Peak
5320	88.93	88.38			31.45	6.29	37.19	100	340	Average
5320	98.44	97.89			31.45	6.29	37.19	100	340	Peak
5350	41.22	40.63	54	-12.78	31.48	6.29	37.18	100	340	Average
5350	60.6	60.01	74	-13.4	31.48	6.29	37.18	100	340	Peak
Antenna Polarity & Test Distance: Vertical at 3 m										
Frequency (MHz)	Emission Level (dBuV/m)	Read Level (dBuV)	Limit (dBuV/m)	Margin (dB)	Antenna Factor (dB/m)	Cable Loss (dB)	Preamp Factor (dB)	Antenna Height (cm)	Table Angle (Degree)	Remark
5028	40.43	40.29	54	-13.57	31.23	6.15	37.24	203	17	Average
5028	61.64	61.5	74	-12.36	31.23	6.15	37.24	203	17	Peak
5320	95.76	95.21			31.45	6.29	37.19	203	17	Average
5320	105.21	104.66			31.45	6.29	37.19	203	17	Peak
5388	42.87	42.23	54	-11.13	31.51	6.31	37.18	203	17	Average
5388	62.27	61.63	74	-11.73	31.51	6.31	37.18	203	17	Peak

Remarks:

- Emission Level = Read Level + Antenna Factor + Cable Loss - Preamp Factor  
Margin value = Emission level – Limit value
- 5320 MHz: Fundamental Frequency

EUT Test Condition		Measurement Detail	
Channel	Channel 100	Frequency Range	1 GHz ~ 40 GHz
Input Power	120 Vac, 60 Hz	Detector Function	Peak (PK) Average (AV)
Environmental Conditions	25 deg. C, 65 % RH	Tested By	Gavin Wu

Antenna Polarity & Test Distance: Horizontal at 3 m										
Frequency (MHz)	Emission Level (dBuV/m)	Read Level (dBuV)	Limit (dBuV/m)	Margin (dB)	Antenna Factor (dB/m)	Cable Loss (dB)	Preamp Factor (dB)	Antenna Height (cm)	Table Angle (Degree)	Remark
5350	39.07	38.48	54	-14.93	31.48	6.29	37.18	177	3	Average
5350	60.1	59.51	74	-13.9	31.48	6.29	37.18	177	3	Peak
5470	58.55	57.72	68.2	-9.65	31.57	6.34	37.08	177	3	Peak
5500	88.6	87.67			31.6	6.36	37.03	177	3	Average
5500	98.42	97.49			31.6	6.36	37.03	177	3	Peak
5725	59.51	58.23	68.2	-8.69	31.96	6.75	37.43	177	3	Peak
Antenna Polarity & Test Distance: Vertical at 3 m										
Frequency (MHz)	Emission Level (dBuV/m)	Read Level (dBuV)	Limit (dBuV/m)	Margin (dB)	Antenna Factor (dB/m)	Cable Loss (dB)	Preamp Factor (dB)	Antenna Height (cm)	Table Angle (Degree)	Remark
5442	39.4	38.64	54	-14.6	31.55	6.34	37.13	200	338	Average
5442	60.91	60.15	74	-13.09	31.55	6.34	37.13	200	338	Peak
5470	59.99	59.16	68.2	-8.21	31.57	6.34	37.08	200	338	Peak
5500	91.33	90.4			31.6	6.36	37.03	200	338	Average
5500	101.53	100.6			31.6	6.36	37.03	200	338	Peak
5725	59.95	58.67	68.2	-8.25	31.96	6.75	37.43	200	338	Peak

Remarks:

- Emission Level = Read Level + Antenna Factor + Cable Loss - Preamp Factor  
Margin value = Emission level – Limit value
- 5500 MHz: Fundamental Frequency
- 5470 MHz & 5725 MHz: Out of Restricted Band

EUT Test Condition		Measurement Detail	
Channel	Channel 116	Frequency Range	1 GHz ~ 40 GHz
Input Power	120 Vac, 60 Hz	Detector Function	Peak (PK) Average (AV)
Environmental Conditions	25 deg. C, 65 % RH	Tested By	Gavin Wu

Antenna Polarity & Test Distance: Horizontal at 3 m										
Frequency (MHz)	Emission Level (dBuV/m)	Read Level (dBuV)	Limit (dBuV/m)	Margin (dB)	Antenna Factor (dB/m)	Cable Loss (dB)	Preamp Factor (dB)	Antenna Height (cm)	Table Angle (Degree)	Remark
5398	38.97	38.31	54	-15.03	31.52	6.32	37.18	183	6	Average
5398	60.57	59.91	74	-13.43	31.52	6.32	37.18	183	6	Peak
5470	57.77	56.94	68.2	-10.43	31.57	6.34	37.08	183	6	Peak
5580	87.77	86.73			31.71	6.49	37.16	183	6	Average
5580	97.41	96.37			31.71	6.49	37.16	183	6	Peak
5725	60.07	58.79	68.2	-8.13	31.96	6.75	37.43	183	6	Peak
Antenna Polarity & Test Distance: Vertical at 3 m										
Frequency (MHz)	Emission Level (dBuV/m)	Read Level (dBuV)	Limit (dBuV/m)	Margin (dB)	Antenna Factor (dB/m)	Cable Loss (dB)	Preamp Factor (dB)	Antenna Height (cm)	Table Angle (Degree)	Remark
5398	40.86	40.2	54	-13.14	31.52	6.32	37.18	202	335	Average
5398	61.12	60.46	74	-12.88	31.52	6.32	37.18	202	335	Peak
5470	58.06	57.23	68.2	-10.14	31.57	6.34	37.08	202	335	Peak
5580	91.41	90.37			31.71	6.49	37.16	202	335	Average
5580	101.67	100.63			31.71	6.49	37.16	202	335	Peak
5725	60.24	58.96	68.2	-7.96	31.96	6.75	37.43	202	335	Peak

Remarks:

- Emission Level = Read Level + Antenna Factor + Cable Loss - Preamp Factor  
Margin value = Emission level – Limit value
- 5580 MHz: Fundamental Frequency
- 5470 MHz & 5725 MHz: Out of Restricted Band

EUT Test Condition		Measurement Detail	
Channel	Channel 140	Frequency Range	1 GHz ~ 40 GHz
Input Power	120 Vac, 60 Hz	Detector Function	Peak (PK) Average (AV)
Environmental Conditions	25 deg. C, 65 % RH	Tested By	Gavin Wu

Antenna Polarity & Test Distance: Horizontal at 3 m										
Frequency (MHz)	Emission Level (dBuV/m)	Read Level (dBuV)	Limit (dBuV/m)	Margin (dB)	Antenna Factor (dB/m)	Cable Loss (dB)	Preamp Factor (dB)	Antenna Height (cm)	Table Angle (Degree)	Remark
5428	39.11	38.39	54	-14.89	31.53	6.32	37.13	202	14	Average
5428	59.57	58.85	74	-14.43	31.53	6.32	37.13	202	14	Peak
5470	57.3	56.47	68.2	-10.9	31.57	6.34	37.08	202	14	Peak
5700	88.5	87.31			31.9	6.69	37.4	202	14	Average
5700	98.58	97.39			31.9	6.69	37.4	202	14	Peak
5725	59.4	58.12	68.2	-8.8	31.96	6.75	37.43	202	14	Peak
Antenna Polarity & Test Distance: Vertical at 3 m										
Frequency (MHz)	Emission Level (dBuV/m)	Read Level (dBuV)	Limit (dBuV/m)	Margin (dB)	Antenna Factor (dB/m)	Cable Loss (dB)	Preamp Factor (dB)	Antenna Height (cm)	Table Angle (Degree)	Remark
5448	39.27	38.5	54	-14.73	31.56	6.34	37.13	224	352	Average
5448	60.74	59.97	74	-13.26	31.56	6.34	37.13	224	352	Peak
5470	58.74	57.91	68.2	-9.46	31.57	6.34	37.08	224	352	Peak
5700	91.62	90.43			31.9	6.69	37.4	224	352	Average
5700	101.88	100.69			31.9	6.69	37.4	224	352	Peak
5725	60.93	59.65	68.2	-7.27	31.96	6.75	37.43	224	352	Peak

Remarks:

- Emission Level = Read Level + Antenna Factor + Cable Loss - Preamp Factor  
Margin value = Emission level – Limit value
- 5700 MHz: Fundamental Frequency
- 5470 MHz & 5725 MHz: Out of Restricted Band

EUT Test Condition		Measurement Detail	
Channel	Channel 149	Frequency Range	1 GHz ~ 40 GHz
Input Power	120 Vac, 60 Hz	Detector Function	Peak (PK) Average (AV)
Environmental Conditions	25 deg. C, 65 % RH	Tested By	Gavin Wu

**Antenna Polarity & Test Distance: Horizontal at 3 m**

Frequency (MHz)	Emission Level (dBuV/m)	Read Level (dBuV)	Limit (dBuV/m)	Margin (dB)	Antenna Factor (dB/m)	Cable Loss (dB)	Preamp Factor (dB)	Antenna Height (cm)	Table Angle (Degree)	Remark
*5714	59.99	58.8	68.2	-8.21	31.93	6.69	37.43	167	22	Peak
*5725	61.53	60.25	78.2	-16.67	31.96	6.75	37.43	167	22	Peak
5745	93.18	91.91			31.99	6.75	37.47	167	22	Average
5745	103.05	101.78			31.99	6.75	37.47	167	22	Peak
*5850	59.44	57.92	78.2	-18.76	32.15	6.88	37.51	167	22	Peak
*5861	60.11	58.48	68.2	-8.09	32.18	6.95	37.5	167	22	Peak

**Antenna Polarity & Test Distance: Vertical at 3 m**

Frequency (MHz)	Emission Level (dBuV/m)	Read Level (dBuV)	Limit (dBuV/m)	Margin (dB)	Antenna Factor (dB/m)	Cable Loss (dB)	Preamp Factor (dB)	Antenna Height (cm)	Table Angle (Degree)	Remark
*5714	60.07	58.88	68.2	-8.13	31.93	6.69	37.43	199	24	Peak
*5725	60.14	58.86	78.2	-18.06	31.96	6.75	37.43	199	24	Peak
5745	91.98	90.71			31.99	6.75	37.47	199	24	Average
5745	101.11	99.84			31.99	6.75	37.47	199	24	Peak
*5850	59.66	58.14	78.2	-18.54	32.15	6.88	37.51	199	24	Peak
*5861	59.66	58.03	68.2	-8.54	32.18	6.95	37.5	199	24	Peak

Remarks:

- Emission Level = Read Level + Antenna Factor + Cable Loss - Preamp Factor  
Margin value = Emission level – Limit value
- 5745 MHz: Fundamental Frequency
- \*: Out of Restricted Band



EUT Test Condition		Measurement Detail	
Channel	Channel 157	Frequency Range	1 GHz ~ 40 GHz
Input Power	120 Vac, 60 Hz	Detector Function	Peak (PK) Average (AV)
Environmental Conditions	25 deg. C, 65 % RH	Tested By	Gavin Wu

**Antenna Polarity & Test Distance: Horizontal at 3 m**

Frequency (MHz)	Emission Level (dBuV/m)	Read Level (dBuV)	Limit (dBuV/m)	Margin (dB)	Antenna Factor (dB/m)	Cable Loss (dB)	Preamp Factor (dB)	Antenna Height (cm)	Table Angle (Degree)	Remark
*5714	60.08	58.89	68.2	-8.12	31.93	6.69	37.43	162	23	Peak
*5725	59.46	58.18	78.2	-18.74	31.96	6.75	37.43	162	23	Peak
5785	93.03	91.71			32.04	6.82	37.54	162	23	Average
5785	103.13	101.81			32.04	6.82	37.54	162	23	Peak
*5850	59.72	58.2	78.2	-18.48	32.15	6.88	37.51	162	23	Peak
*5861	60.38	58.75	68.2	-7.82	32.18	6.95	37.5	162	23	Peak

**Antenna Polarity & Test Distance: Vertical at 3 m**

Frequency (MHz)	Emission Level (dBuV/m)	Read Level (dBuV)	Limit (dBuV/m)	Margin (dB)	Antenna Factor (dB/m)	Cable Loss (dB)	Preamp Factor (dB)	Antenna Height (cm)	Table Angle (Degree)	Remark
*5714	60.1	58.91	68.2	-8.1	31.93	6.69	37.43	198	20	Peak
*5725	60.36	59.08	78.2	-17.84	31.96	6.75	37.43	198	20	Peak
5785	91.04	89.72			32.04	6.82	37.54	198	20	Average
5785	101.19	99.87			32.04	6.82	37.54	198	20	Peak
*5850	58.89	57.37	78.2	-19.31	32.15	6.88	37.51	198	20	Peak
*5861	59.52	57.89	68.2	-8.68	32.18	6.95	37.5	198	20	Peak

Remarks:

- Emission Level = Read Level + Antenna Factor + Cable Loss - Preamp Factor  
Margin value = Emission level – Limit value
- 5785 MHz: Fundamental Frequency
- \*: Out of Restricted Band

EUT Test Condition		Measurement Detail	
Channel	Channel 165	Frequency Range	1 GHz ~ 40 GHz
Input Power	120 Vac, 60 Hz	Detector Function	Peak (PK) Average (AV)
Environmental Conditions	25 deg. C, 65 % RH	Tested By	Gavin Wu

Antenna Polarity & Test Distance: Horizontal at 3 m										
Frequency (MHz)	Emission Level (dBuV/m)	Read Level (dBuV)	Limit (dBuV/m)	Margin (dB)	Antenna Factor (dB/m)	Cable Loss (dB)	Preamp Factor (dB)	Antenna Height (cm)	Table Angle (Degree)	Remark
*5714	60	58.81	68.2	-8.2	31.93	6.69	37.43	162	28	Peak
*5725	59.62	58.34	78.2	-18.58	31.96	6.75	37.43	162	28	Peak
5825	93.19	91.72			32.12	6.88	37.53	162	28	Average
5825	103.12	101.65			32.12	6.88	37.53	162	28	Peak
*5850	59.76	58.24	78.2	-18.44	32.15	6.88	37.51	162	28	Peak
*5861	61.1	59.47	68.2	-7.1	32.18	6.95	37.5	162	28	Peak
Antenna Polarity & Test Distance: Vertical at 3 m										
Frequency (MHz)	Emission Level (dBuV/m)	Read Level (dBuV)	Limit (dBuV/m)	Margin (dB)	Antenna Factor (dB/m)	Cable Loss (dB)	Preamp Factor (dB)	Antenna Height (cm)	Table Angle (Degree)	Remark
*5714	60.35	59.16	68.2	-7.85	31.93	6.69	37.43	180	62	Peak
*5725	59.72	58.44	78.2	-18.48	31.96	6.75	37.43	180	62	Peak
5825	91.09	89.62			32.12	6.88	37.53	180	62	Average
5825	101.21	99.74			32.12	6.88	37.53	180	62	Peak
*5850	60.41	58.89	78.2	-17.79	32.15	6.88	37.51	180	62	Peak
*5861	59.25	57.62	68.2	-8.95	32.18	6.95	37.5	180	62	Peak

Remarks:

- Emission Level = Read Level + Antenna Factor + Cable Loss - Preamp Factor  
Margin value = Emission level – Limit value
- 5825 MHz: Fundamental Frequency
- \*: Out of Restricted Band

802.11ac (VHT40)

EUT Test Condition		Measurement Detail	
Channel	Channel 38	Frequency Range	1 GHz ~ 40 GHz
Input Power	120 Vac, 60 Hz	Detector Function	Peak (PK) Average (AV)
Environmental Conditions	25 deg. C, 65 % RH	Tested By	Toby Tian

Antenna Polarity & Test Distance: Horizontal at 3 m										
Frequency (MHz)	Emission Level (dBuV/m)	Read Level (dBuV)	Limit (dBuV/m)	Margin (dB)	Antenna Factor (dB/m)	Cable Loss (dB)	Preamp Factor (dB)	Antenna Height (cm)	Table Angle (Degree)	Remark
5142	40.3	40.08	54	-13.7	31.32	6.2	37.3	200	53	Average
5142	60.15	59.93	74	-13.85	31.32	6.2	37.3	200	53	Peak
5190	86.05	85.82			31.35	6.22	37.34	200	53	Average
5190	96.43	96.2			31.35	6.22	37.34	200	53	Peak
5382	38.92	38.28	54	-15.08	31.51	6.31	37.18	200	53	Average
5382	61.03	60.39	74	-12.97	31.51	6.31	37.18	200	53	Peak

Antenna Polarity & Test Distance: Vertical at 3 m										
Frequency (MHz)	Emission Level (dBuV/m)	Read Level (dBuV)	Limit (dBuV/m)	Margin (dB)	Antenna Factor (dB/m)	Cable Loss (dB)	Preamp Factor (dB)	Antenna Height (cm)	Table Angle (Degree)	Remark
5086	43.13	42.96	54	-10.87	31.27	6.17	37.27	190	29	Average
5086	61.37	61.2	74	-12.63	31.27	6.17	37.27	190	29	Peak
5190	89.27	89.04			31.35	6.22	37.34	190	29	Average
5190	99.14	98.91			31.35	6.22	37.34	190	29	Peak
5420	39.09	38.42	54	-14.91	31.53	6.32	37.18	190	29	Average
5420	60.71	60.04	74	-13.29	31.53	6.32	37.18	190	29	Peak

Remarks:

- Emission Level = Read Level + Antenna Factor + Cable Loss - Preamp Factor  
Margin value = Emission level – Limit value
- 5190 MHz: Fundamental Frequency

EUT Test Condition		Measurement Detail	
Channel	Channel 46	Frequency Range	1 GHz ~ 40 GHz
Input Power	120 Vac, 60 Hz	Detector Function	Peak (PK) Average (AV)
Environmental Conditions	25 deg. C, 65 % RH	Tested By	Toby Tian

Antenna Polarity & Test Distance: Horizontal at 3 m										
Frequency (MHz)	Emission Level (dBuV/m)	Read Level (dBuV)	Limit (dBuV/m)	Margin (dB)	Antenna Factor (dB/m)	Cable Loss (dB)	Preamp Factor (dB)	Antenna Height (cm)	Table Angle (Degree)	Remark
5056	39.76	39.59	54	-14.24	31.25	6.17	37.25	191	46	Average
5056	60.63	60.46	74	-13.37	31.25	6.17	37.25	191	46	Peak
5230	86.08	85.77			31.39	6.24	37.32	191	46	Average
5230	96.71	96.4			31.39	6.24	37.32	191	46	Peak
5406	40.44	39.78	54	-13.56	31.52	6.32	37.18	191	46	Average
5406	60.22	59.56	74	-13.78	31.52	6.32	37.18	191	46	Peak

Antenna Polarity & Test Distance: Vertical at 3 m										
Frequency (MHz)	Emission Level (dBuV/m)	Read Level (dBuV)	Limit (dBuV/m)	Margin (dB)	Antenna Factor (dB/m)	Cable Loss (dB)	Preamp Factor (dB)	Antenna Height (cm)	Table Angle (Degree)	Remark
5124	40.56	40.36	54	-13.44	31.31	6.19	37.3	188	30	Average
5124	60.93	60.73	74	-13.07	31.31	6.19	37.3	188	30	Peak
5230	89.76	89.45			31.39	6.24	37.32	188	30	Average
5230	99.41	99.1			31.39	6.24	37.32	188	30	Peak
5448	40.67	39.9	54	-13.33	31.56	6.34	37.13	188	30	Average
5448	60.46	59.69	74	-13.54	31.56	6.34	37.13	188	30	Peak

Remarks:

- Emission Level = Read Level + Antenna Factor + Cable Loss - Preamp Factor  
Margin value = Emission level – Limit value
- 5230 MHz: Fundamental Frequency

EUT Test Condition		Measurement Detail	
Channel	Channel 54	Frequency Range	1 GHz ~ 40 GHz
Input Power	120 Vac, 60 Hz	Detector Function	Peak (PK) Average (AV)
Environmental Conditions	25 deg. C, 65 % RH	Tested By	Gavin Wu

Antenna Polarity & Test Distance: Horizontal at 3 m										
Frequency (MHz)	Emission Level (dBuV/m)	Read Level (dBuV)	Limit (dBuV/m)	Margin (dB)	Antenna Factor (dB/m)	Cable Loss (dB)	Preamp Factor (dB)	Antenna Height (cm)	Table Angle (Degree)	Remark
5012	40.31	40.2	54	-13.69	31.21	6.13	37.23	100	341	Average
5012	59.57	59.46	74	-14.43	31.21	6.13	37.23	100	341	Peak
5270	82.63	82.24			31.41	6.25	37.27	100	341	Average
5270	92.55	92.16			31.41	6.25	37.27	100	341	Peak
5360	40.57	39.96	54	-13.43	31.48	6.31	37.18	100	341	Average
5360	60.24	59.63	74	-13.76	31.48	6.31	37.18	100	341	Peak
Antenna Polarity & Test Distance: Vertical at 3 m										
Frequency (MHz)	Emission Level (dBuV/m)	Read Level (dBuV)	Limit (dBuV/m)	Margin (dB)	Antenna Factor (dB/m)	Cable Loss (dB)	Preamp Factor (dB)	Antenna Height (cm)	Table Angle (Degree)	Remark
5144	41.45	41.25	54	-12.55	31.32	6.2	37.32	198	11	Average
5144	60.47	60.27	74	-13.53	31.32	6.2	37.32	198	11	Peak
5270	89.38	88.99			31.41	6.25	37.27	198	11	Average
5270	99.27	98.88			31.41	6.25	37.27	198	11	Peak
5454	40.64	39.82	54	-13.36	31.56	6.34	37.08	198	11	Average
5454	60.85	60.03	74	-13.15	31.56	6.34	37.08	198	11	Peak

Remarks:

- Emission Level = Read Level + Antenna Factor + Cable Loss - Preamp Factor  
Margin value = Emission level – Limit value
- 5270 MHz: Fundamental Frequency

EUT Test Condition		Measurement Detail	
Channel	Channel 62	Frequency Range	1 GHz ~ 40 GHz
Input Power	120 Vac, 60 Hz	Detector Function	Peak (PK) Average (AV)
Environmental Conditions	25 deg. C, 65 % RH	Tested By	Gavin Wu

Antenna Polarity & Test Distance: Horizontal at 3 m										
Frequency (MHz)	Emission Level (dBuV/m)	Read Level (dBuV)	Limit (dBuV/m)	Margin (dB)	Antenna Factor (dB/m)	Cable Loss (dB)	Preamp Factor (dB)	Antenna Height (cm)	Table Angle (Degree)	Remark
5084	40.2	40.03	54	-13.8	31.27	6.17	37.27	100	344	Average
5084	61.97	61.8	74	-12.03	31.27	6.17	37.27	100	344	Peak
5310	83.5	82.97			31.45	6.27	37.19	100	344	Average
5310	93.82	93.29			31.45	6.27	37.19	100	344	Peak
5436	41.51	40.77	54	-12.49	31.55	6.32	37.13	100	344	Average
5436	61.59	60.85	74	-12.41	31.55	6.32	37.13	100	344	Peak

Antenna Polarity & Test Distance: Vertical at 3 m										
Frequency (MHz)	Emission Level (dBuV/m)	Read Level (dBuV)	Limit (dBuV/m)	Margin (dB)	Antenna Factor (dB/m)	Cable Loss (dB)	Preamp Factor (dB)	Antenna Height (cm)	Table Angle (Degree)	Remark
5040	40.47	40.32	54	-13.53	31.24	6.15	37.24	208	10	Average
5040	60.62	60.47	74	-13.38	31.24	6.15	37.24	208	10	Peak
5310	88.01	87.48			31.45	6.27	37.19	208	10	Average
5310	98.63	98.1			31.45	6.27	37.19	208	10	Peak
5352	44.03	43.44	54	-9.97	31.48	6.29	37.18	208	10	Average
5352	61.76	61.17	74	-12.24	31.48	6.29	37.18	208	10	Peak

Remarks:

- Emission Level = Read Level + Antenna Factor + Cable Loss - Preamp Factor  
Margin value = Emission level – Limit value
- 5310 MHz: Fundamental Frequency

EUT Test Condition		Measurement Detail	
Channel	Channel 102	Frequency Range	1 GHz ~ 40 GHz
Input Power	120 Vac, 60 Hz	Detector Function	Peak (PK) Average (AV)
Environmental Conditions	25 deg. C, 65 % RH	Tested By	Gavin Wu

Antenna Polarity & Test Distance: Horizontal at 3 m										
Frequency (MHz)	Emission Level (dBuV/m)	Read Level (dBuV)	Limit (dBuV/m)	Margin (dB)	Antenna Factor (dB/m)	Cable Loss (dB)	Preamp Factor (dB)	Antenna Height (cm)	Table Angle (Degree)	Remark
5378	38.88	38.24	54	-15.12	31.51	6.31	37.18	161	16	Average
5378	60.32	59.68	74	-13.68	31.51	6.31	37.18	161	16	Peak
5470	57.24	56.41	68.2	-10.96	31.57	6.34	37.08	161	16	Peak
5510	83.51	82.61			31.6	6.36	37.06	161	16	Average
5510	93.15	92.25			31.6	6.36	37.06	161	16	Peak
5725	59.43	58.15	68.2	-8.77	31.96	6.75	37.43	161	16	Peak
Antenna Polarity & Test Distance: Vertical at 3 m										
Frequency (MHz)	Emission Level (dBuV/m)	Read Level (dBuV)	Limit (dBuV/m)	Margin (dB)	Antenna Factor (dB/m)	Cable Loss (dB)	Preamp Factor (dB)	Antenna Height (cm)	Table Angle (Degree)	Remark
5456	39.69	38.87	54	-14.31	31.56	6.34	37.08	222	344	Average
5456	61.66	60.84	74	-12.34	31.56	6.34	37.08	222	344	Peak
5470	59.7	58.87	68.2	-8.5	31.57	6.34	37.08	222	344	Peak
5510	86.54	85.64			31.6	6.36	37.06	222	344	Average
5510	96.57	95.67			31.6	6.36	37.06	222	344	Peak
5725	60.73	59.45	68.2	-7.47	31.96	6.75	37.43	222	344	Peak

Remarks:

- Emission Level = Read Level + Antenna Factor + Cable Loss - Preamp Factor  
Margin value = Emission level – Limit value
- 5510 MHz: Fundamental Frequency
- 5470 MHz & 5725 MHz: Out of Restricted Band

EUT Test Condition		Measurement Detail	
Channel	Channel 110	Frequency Range	1 GHz ~ 40 GHz
Input Power	120 Vac, 60 Hz	Detector Function	Peak (PK) Average (AV)
Environmental Conditions	25 deg. C, 65 % RH	Tested By	Gavin Wu

Antenna Polarity & Test Distance: Horizontal at 3 m										
Frequency (MHz)	Emission Level (dBuV/m)	Read Level (dBuV)	Limit (dBuV/m)	Margin (dB)	Antenna Factor (dB/m)	Cable Loss (dB)	Preamp Factor (dB)	Antenna Height (cm)	Table Angle (Degree)	Remark
5440	39	38.24	54	-15	31.55	6.34	37.13	167	18	Average
5440	60.17	59.41	74	-13.83	31.55	6.34	37.13	167	18	Peak
5470	59.29	58.46	68.2	-8.91	31.57	6.34	37.08	167	18	Peak
5550	83.25	82.24			31.68	6.42	37.09	167	18	Average
5550	93.5	92.49			31.68	6.42	37.09	167	18	Peak
5725	58.42	57.14	68.2	-9.78	31.96	6.75	37.43	167	18	Peak
Antenna Polarity & Test Distance: Vertical at 3 m										
Frequency (MHz)	Emission Level (dBuV/m)	Read Level (dBuV)	Limit (dBuV/m)	Margin (dB)	Antenna Factor (dB/m)	Cable Loss (dB)	Preamp Factor (dB)	Antenna Height (cm)	Table Angle (Degree)	Remark
5402	38.89	38.23	54	-15.11	31.52	6.32	37.18	218	345	Average
5402	60.35	59.69	74	-13.65	31.52	6.32	37.18	218	345	Peak
5470	59.21	58.38	68.2	-8.99	31.57	6.34	37.08	218	345	Peak
5550	86.01	85			31.68	6.42	37.09	218	345	Average
5550	96	94.99			31.68	6.42	37.09	218	345	Peak
5725	60.01	58.73	68.2	-8.19	31.96	6.75	37.43	218	345	Peak

Remarks:

- Emission Level = Read Level + Antenna Factor + Cable Loss - Preamp Factor  
Margin value = Emission level – Limit value
- 5550 MHz: Fundamental Frequency
- 5470 MHz & 5725 MHz: Out of Restricted Band



EUT Test Condition		Measurement Detail	
Channel	Channel 134	Frequency Range	1 GHz ~ 40 GHz
Input Power	120 Vac, 60 Hz	Detector Function	Peak (PK) Average (AV)
Environmental Conditions	25 deg. C, 65 % RH	Tested By	Gavin Wu

Antenna Polarity & Test Distance: Horizontal at 3 m										
Frequency (MHz)	Emission Level (dBuV/m)	Read Level (dBuV)	Limit (dBuV/m)	Margin (dB)	Antenna Factor (dB/m)	Cable Loss (dB)	Preamp Factor (dB)	Antenna Height (cm)	Table Angle (Degree)	Remark
5394	38.86	38.22	54	-15.14	31.51	6.31	37.18	171	21	Average
5394	60.08	59.44	74	-13.92	31.51	6.31	37.18	171	21	Peak
5470	58.05	57.22	68.2	-10.15	31.57	6.34	37.08	171	21	Peak
5670	83.73	82.57			31.88	6.62	37.34	171	21	Average
5670	93.96	92.8			31.88	6.62	37.34	171	21	Peak
5725	58.24	56.96	68.2	-9.96	31.96	6.75	37.43	171	21	Peak
Antenna Polarity & Test Distance: Vertical at 3 m										
Frequency (MHz)	Emission Level (dBuV/m)	Read Level (dBuV)	Limit (dBuV/m)	Margin (dB)	Antenna Factor (dB/m)	Cable Loss (dB)	Preamp Factor (dB)	Antenna Height (cm)	Table Angle (Degree)	Remark
5428	39.12	38.4	54	-14.88	31.53	6.32	37.13	220	349	Average
5428	61.09	60.37	74	-12.91	31.53	6.32	37.13	220	349	Peak
5470	58.5	57.67	68.2	-9.7	31.57	6.34	37.08	220	349	Peak
5670	86.26	85.1			31.88	6.62	37.34	220	349	Average
5670	96.15	94.99			31.88	6.62	37.34	220	349	Peak
5725	58.89	57.61	68.2	-9.31	31.96	6.75	37.43	220	349	Peak

Remarks:

- Emission Level = Read Level + Antenna Factor + Cable Loss - Preamp Factor  
Margin value = Emission level – Limit value
- 5670 MHz: Fundamental Frequency
- 5470 MHz & 5725 MHz: Out of Restricted Band

EUT Test Condition		Measurement Detail	
Channel	Channel 151	Frequency Range	1 GHz ~ 40 GHz
Input Power	120 Vac, 60 Hz	Detector Function	Peak (PK) Average (AV)
Environmental Conditions	25 deg. C, 65 % RH	Tested By	Gavin Wu

Antenna Polarity & Test Distance: Horizontal at 3 m										
Frequency (MHz)	Emission Level (dBuV/m)	Read Level (dBuV)	Limit (dBuV/m)	Margin (dB)	Antenna Factor (dB/m)	Cable Loss (dB)	Preamp Factor (dB)	Antenna Height (cm)	Table Angle (Degree)	Remark
*5714	60.9	59.71	68.2	-7.3	31.93	6.69	37.43	156	38	Peak
*5725	64.67	63.39	78.2	-13.53	31.96	6.75	37.43	156	38	Peak
5755	88.99	87.7			32.01	6.75	37.47	156	38	Average
5755	98.99	97.7			32.01	6.75	37.47	156	38	Peak
*5850	60.18	58.66	78.2	-18.02	32.15	6.88	37.51	156	38	Peak
*5861	60.17	58.54	68.2	-8.03	32.18	6.95	37.5	156	38	Peak
Antenna Polarity & Test Distance: Vertical at 3 m										
Frequency (MHz)	Emission Level (dBuV/m)	Read Level (dBuV)	Limit (dBuV/m)	Margin (dB)	Antenna Factor (dB/m)	Cable Loss (dB)	Preamp Factor (dB)	Antenna Height (cm)	Table Angle (Degree)	Remark
*5714	60.42	59.23	68.2	-7.78	31.93	6.69	37.43	199	9	Peak
*5725	61.96	60.68	78.2	-16.24	31.96	6.75	37.43	199	9	Peak
5755	86.75	85.46			32.01	6.75	37.47	199	9	Average
5755	96.8	95.51			32.01	6.75	37.47	199	9	Peak
*5850	61.34	59.82	78.2	-16.86	32.15	6.88	37.51	199	9	Peak
*5861	59.93	58.3	68.2	-8.27	32.18	6.95	37.5	199	9	Peak

Remarks:

- Emission Level = Read Level + Antenna Factor + Cable Loss - Preamp Factor  
Margin value = Emission level – Limit value
- 5755 MHz: Fundamental Frequency
- \*: Out of Restricted Band

EUT Test Condition		Measurement Detail	
Channel	Channel 159	Frequency Range	1 GHz ~ 40 GHz
Input Power	120 Vac, 60 Hz	Detector Function	Peak (PK) Average (AV)
Environmental Conditions	25 deg. C, 65 % RH	Tested By	Gavin Wu

Antenna Polarity & Test Distance: Horizontal at 3 m										
Frequency (MHz)	Emission Level (dBuV/m)	Read Level (dBuV)	Limit (dBuV/m)	Margin (dB)	Antenna Factor (dB/m)	Cable Loss (dB)	Preamp Factor (dB)	Antenna Height (cm)	Table Angle (Degree)	Remark
*5714	60.19	59	68.2	-8.01	31.93	6.69	37.43	154	30	Peak
*5725	59.91	58.63	78.2	-18.29	31.96	6.75	37.43	154	30	Peak
5795	88.92	87.57			32.07	6.82	37.54	154	30	Average
5795	98.11	96.76			32.07	6.82	37.54	154	30	Peak
*5850	61.77	60.25	78.2	-16.43	32.15	6.88	37.51	154	30	Peak
*5861	61.28	59.65	68.2	-6.92	32.18	6.95	37.5	154	30	Peak

Antenna Polarity & Test Distance: Vertical at 3 m										
Frequency (MHz)	Emission Level (dBuV/m)	Read Level (dBuV)	Limit (dBuV/m)	Margin (dB)	Antenna Factor (dB/m)	Cable Loss (dB)	Preamp Factor (dB)	Antenna Height (cm)	Table Angle (Degree)	Remark
*5714	59.02	57.83	68.2	-9.18	31.93	6.69	37.43	197	21	Peak
*5725	60.86	59.58	78.2	-17.34	31.96	6.75	37.43	197	21	Peak
5795	86.18	84.83			32.07	6.82	37.54	197	21	Average
5795	96.19	94.84			32.07	6.82	37.54	197	21	Peak
*5850	59.9	58.38	78.2	-18.3	32.15	6.88	37.51	197	21	Peak
*5861	60.02	58.39	68.2	-8.18	32.18	6.95	37.5	197	21	Peak

Remarks:

- Emission Level = Read Level + Antenna Factor + Cable Loss - Preamp Factor  
Margin value = Emission level – Limit value
- 5795 MHz: Fundamental Frequency
- \*: Out of Restricted Band

802.11ac (VHT80)

EUT Test Condition		Measurement Detail	
Channel	Channel 42	Frequency Range	1 GHz ~ 40 GHz
Input Power	120 Vac, 60 Hz	Detector Function	Peak (PK) Average (AV)
Environmental Conditions	25 deg. C, 65 % RH	Tested By	Toby Tian

Antenna Polarity & Test Distance: Horizontal at 3 m										
Frequency (MHz)	Emission Level (dBuV/m)	Read Level (dBuV)	Limit (dBuV/m)	Margin (dB)	Antenna Factor (dB/m)	Cable Loss (dB)	Preamp Factor (dB)	Antenna Height (cm)	Table Angle (Degree)	Remark
5106	40.87	40.67	54	-13.13	31.29	6.19	37.28	194	59	Average
5106	60.97	60.77	74	-13.03	31.29	6.19	37.28	194	59	Peak
5210	82.83	82.58			31.37	6.24	37.36	194	59	Average
5210	92.18	91.93			31.37	6.24	37.36	194	59	Peak
5442	39.31	38.55	54	-14.69	31.55	6.34	37.13	194	59	Average
5442	60.56	59.8	74	-13.44	31.55	6.34	37.13	194	59	Peak

Antenna Polarity & Test Distance: Vertical at 3 m										
Frequency (MHz)	Emission Level (dBuV/m)	Read Level (dBuV)	Limit (dBuV/m)	Margin (dB)	Antenna Factor (dB/m)	Cable Loss (dB)	Preamp Factor (dB)	Antenna Height (cm)	Table Angle (Degree)	Remark
5084	43.19	43.02	54	-10.81	31.27	6.17	37.27	194	40	Average
5084	60.11	59.94	74	-13.89	31.27	6.17	37.27	194	40	Peak
5210	84.95	84.7			31.37	6.24	37.36	194	40	Average
5210	94.8	94.55			31.37	6.24	37.36	194	40	Peak
5388	39.5	38.86	54	-14.5	31.51	6.31	37.18	194	40	Average
5388	60.8	60.16	74	-13.2	31.51	6.31	37.18	194	40	Peak

Remarks:

- Emission Level = Read Level + Antenna Factor + Cable Loss - Preamp Factor  
Margin value = Emission level – Limit value
- 5210 MHz: Fundamental Frequency

EUT Test Condition		Measurement Detail	
Channel	Channel 58	Frequency Range	1 GHz ~ 40 GHz
Input Power	120 Vac, 60 Hz	Detector Function	Peak (PK) Average (AV)
Environmental Conditions	25 deg. C, 65 % RH	Tested By	Gavin Wu

Antenna Polarity & Test Distance: Horizontal at 3 m										
Frequency (MHz)	Emission Level (dBuV/m)	Read Level (dBuV)	Limit (dBuV/m)	Margin (dB)	Antenna Factor (dB/m)	Cable Loss (dB)	Preamp Factor (dB)	Antenna Height (cm)	Table Angle (Degree)	Remark
5148	41.17	40.97	54	-12.83	31.32	6.2	37.32	100	343	Average
5148	60.5	60.3	74	-13.5	31.32	6.2	37.32	100	343	Peak
5290	78.75	78.28			31.43	6.27	37.23	100	343	Average
5290	88.67	88.2			31.43	6.27	37.23	100	343	Peak
5458	42.6	41.78	54	-11.4	31.56	6.34	37.08	100	343	Average
5458	61.21	60.39	74	-12.79	31.56	6.34	37.08	100	343	Peak
Antenna Polarity & Test Distance: Vertical at 3 m										
Frequency (MHz)	Emission Level (dBuV/m)	Read Level (dBuV)	Limit (dBuV/m)	Margin (dB)	Antenna Factor (dB/m)	Cable Loss (dB)	Preamp Factor (dB)	Antenna Height (cm)	Table Angle (Degree)	Remark
5098	40.82	40.63	54	-13.18	31.28	6.19	37.28	200	11	Average
5098	61.26	61.07	74	-12.74	31.28	6.19	37.28	200	11	Peak
5290	84.59	84.12			31.43	6.27	37.23	200	11	Average
5290	94.07	93.6			31.43	6.27	37.23	200	11	Peak
5398	46.07	45.41	54	-7.93	31.52	6.32	37.18	200	11	Average
5398	61.01	60.35	74	-12.99	31.52	6.32	37.18	200	11	Peak

Remarks:

- Emission Level = Read Level + Antenna Factor + Cable Loss - Preamp Factor  
Margin value = Emission level – Limit value
- 5290 MHz: Fundamental Frequency

EUT Test Condition		Measurement Detail	
Channel	Channel 106	Frequency Range	1 GHz ~ 40 GHz
Input Power	120 Vac, 60 Hz	Detector Function	Peak (PK) Average (AV)
Environmental Conditions	25 deg. C, 65 % RH	Tested By	Gavin Wu

Antenna Polarity & Test Distance: Horizontal at 3 m										
Frequency (MHz)	Emission Level (dBuV/m)	Read Level (dBuV)	Limit (dBuV/m)	Margin (dB)	Antenna Factor (dB/m)	Cable Loss (dB)	Preamp Factor (dB)	Antenna Height (cm)	Table Angle (Degree)	Remark
5414	39.89	39.22	54	-14.11	31.53	6.32	37.18	169	14	Average
5414	61.96	61.29	74	-12.04	31.53	6.32	37.18	169	14	Peak
5470	60.09	59.26	68.2	-8.11	31.57	6.34	37.08	169	14	Peak
5530	79.11	78.15			31.63	6.42	37.09	169	14	Average
5530	89.03	88.07			31.63	6.42	37.09	169	14	Peak
5725	61.08	59.8	68.2	-7.12	31.96	6.75	37.43	169	14	Peak
Antenna Polarity & Test Distance: Vertical at 3 m										
Frequency (MHz)	Emission Level (dBuV/m)	Read Level (dBuV)	Limit (dBuV/m)	Margin (dB)	Antenna Factor (dB/m)	Cable Loss (dB)	Preamp Factor (dB)	Antenna Height (cm)	Table Angle (Degree)	Remark
5452	39.25	38.43	54	-14.75	31.56	6.34	37.08	217	351	Average
5452	60.18	59.36	74	-13.82	31.56	6.34	37.08	217	351	Peak
5470	58.2	57.37	68.2	-10	31.57	6.34	37.08	217	351	Peak
5530	76.62	75.66			31.63	6.42	37.09	217	351	Average
5530	86.37	85.41			31.63	6.42	37.09	217	351	Peak
5725	60.67	59.39	68.2	-7.53	31.96	6.75	37.43	217	351	Peak

Remarks:

- Emission Level = Read Level + Antenna Factor + Cable Loss - Preamp Factor  
Margin value = Emission level – Limit value
- 5530 MHz: Fundamental Frequency
- 5470 MHz & 5725 MHz: Out of Restricted Band

EUT Test Condition		Measurement Detail	
Channel	Channel 122	Frequency Range	1 GHz ~ 40 GHz
Input Power	120 Vac, 60 Hz	Detector Function	Peak (PK) Average (AV)
Environmental Conditions	25 deg. C, 65 % RH	Tested By	Gavin Wu

Antenna Polarity & Test Distance: Horizontal at 3 m										
Frequency (MHz)	Emission Level (dBuV/m)	Read Level (dBuV)	Limit (dBuV/m)	Margin (dB)	Antenna Factor (dB/m)	Cable Loss (dB)	Preamp Factor (dB)	Antenna Height (cm)	Table Angle (Degree)	Remark
5374	39.29	38.67	54	-14.71	31.49	6.31	37.18	202	349	Average
5374	61.24	60.62	74	-12.76	31.49	6.31	37.18	202	349	Peak
5470	59.75	58.92	68.2	-8.45	31.57	6.34	37.08	202	349	Peak
5610	77.82	76.71			31.77	6.56	37.22	202	349	Average
5610	92.08	90.97			31.77	6.56	37.22	202	349	Peak
5725	59.58	58.3	68.2	-8.62	31.96	6.75	37.43	202	349	Peak
Antenna Polarity & Test Distance: Vertical at 3 m										
Frequency (MHz)	Emission Level (dBuV/m)	Read Level (dBuV)	Limit (dBuV/m)	Margin (dB)	Antenna Factor (dB/m)	Cable Loss (dB)	Preamp Factor (dB)	Antenna Height (cm)	Table Angle (Degree)	Remark
5412	38.84	38.17	54	-15.16	31.53	6.32	37.18	198	14	Average
5412	60.78	60.11	74	-13.22	31.53	6.32	37.18	198	14	Peak
5470	58.85	58.02	68.2	-9.35	31.57	6.34	37.08	198	14	Peak
5610	75.38	74.27			31.77	6.56	37.22	198	14	Average
5610	89.8	88.69			31.77	6.56	37.22	198	14	Peak
5725	60.85	59.57	68.2	-7.35	31.96	6.75	37.43	198	14	Peak

Remarks:

- Emission Level = Read Level + Antenna Factor + Cable Loss - Preamp Factor  
Margin value = Emission level – Limit value
- 5610 MHz: Fundamental Frequency
- 5470 MHz & 5725 MHz: Out of Restricted Band

EUT Test Condition		Measurement Detail	
Channel	Channel 155	Frequency Range	1 GHz ~ 40 GHz
Input Power	120 Vac, 60 Hz	Detector Function	Peak (PK) Average (AV)
Environmental Conditions	25 deg. C, 65 % RH	Tested By	Gavin Wu

Antenna Polarity & Test Distance: Horizontal at 3 m										
Frequency (MHz)	Emission Level (dBuV/m)	Read Level (dBuV)	Limit (dBuV/m)	Margin (dB)	Antenna Factor (dB/m)	Cable Loss (dB)	Preamp Factor (dB)	Antenna Height (cm)	Table Angle (Degree)	Remark
*5714	60.74	59.55	68.2	-7.46	31.93	6.69	37.43	162	37	Peak
*5725	60.04	58.76	78.2	-18.16	31.96	6.75	37.43	162	37	Peak
5775	83.68	82.32			32.04	6.82	37.5	162	37	Average
5775	93.78	92.42			32.04	6.82	37.5	162	37	Peak
*5850	59.88	58.36	78.2	-18.32	32.15	6.88	37.51	162	37	Peak
*5861	60.05	58.42	68.2	-8.15	32.18	6.95	37.5	162	37	Peak
Antenna Polarity & Test Distance: Vertical at 3 m										
Frequency (MHz)	Emission Level (dBuV/m)	Read Level (dBuV)	Limit (dBuV/m)	Margin (dB)	Antenna Factor (dB/m)	Cable Loss (dB)	Preamp Factor (dB)	Antenna Height (cm)	Table Angle (Degree)	Remark
*5714	59.66	58.47	68.2	-8.54	31.93	6.69	37.43	199	15	Peak
*5725	59.86	58.58	78.2	-18.34	31.96	6.75	37.43	199	15	Peak
5775	81.88	80.52			32.04	6.82	37.5	199	15	Average
5775	91.99	90.63			32.04	6.82	37.5	199	15	Peak
*5850	61.15	59.63	78.2	-17.05	32.15	6.88	37.51	199	15	Peak
*5861	59.84	58.21	68.2	-8.36	32.18	6.95	37.5	199	15	Peak

Remarks:

- Emission Level = Read Level + Antenna Factor + Cable Loss - Preamp Factor  
Margin value = Emission level – Limit value
- 5775 MHz: Fundamental Frequency
- \*: Out of Restricted Band



### Mode C

### 802.11a

EUT Test Condition		Measurement Detail	
Channel	Channel 36	Frequency Range	1 GHz ~ 40 GHz
Input Power	120 Vac, 60 Hz	Detector Function	Peak (PK) Average (AV)
Environmental Conditions	25 deg. C, 65 % RH	Tested By	Toby Tian

Antenna Polarity & Test Distance: Horizontal at 3 m										
Frequency (MHz)	Emission Level (dBuV/m)	Read Level (dBuV)	Limit (dBuV/m)	Margin (dB)	Antenna Factor (dB/m)	Cable Loss (dB)	Preamp Factor (dB)	Antenna Height (cm)	Table Angle (Degree)	Remark
5148	43.64	43.44	54	-10.36	31.32	6.2	37.32	101	68	Average
5148	60.52	60.32	74	-13.48	31.32	6.2	37.32	101	68	Peak
5180	94.26	94.03			31.35	6.22	37.34	101	68	Average
5180	104.55	104.32			31.35	6.22	37.34	101	68	Peak
5362	38.28	37.66	54	-15.72	31.49	6.31	37.18	101	68	Average
5362	59.45	58.83	74	-14.55	31.49	6.31	37.18	101	68	Peak

Antenna Polarity & Test Distance: Vertical at 3 m										
Frequency (MHz)	Emission Level (dBuV/m)	Read Level (dBuV)	Limit (dBuV/m)	Margin (dB)	Antenna Factor (dB/m)	Cable Loss (dB)	Preamp Factor (dB)	Antenna Height (cm)	Table Angle (Degree)	Remark
5150	42.1	41.9	54	-11.9	31.32	6.2	37.32	100	343	Average
5150	61.49	61.29	74	-12.51	31.32	6.2	37.32	100	343	Peak
5180	92.04	91.81			31.35	6.22	37.34	100	343	Average
5180	102.39	102.16			31.35	6.22	37.34	100	343	Peak
5436	38.35	37.61	54	-15.65	31.55	6.32	37.13	100	343	Average
5436	59.12	58.38	74	-14.88	31.55	6.32	37.13	100	343	Peak

Remarks:

- Emission Level = Read Level + Antenna Factor + Cable Loss - Preamp Factor  
Margin value = Emission level – Limit value
- 5180 MHz: Fundamental Frequency

EUT Test Condition		Measurement Detail	
Channel	Channel 44	Frequency Range	1 GHz ~ 40 GHz
Input Power	120 Vac, 60 Hz	Detector Function	Peak (PK) Average (AV)
Environmental Conditions	25 deg. C, 65 % RH	Tested By	Toby Tian

Antenna Polarity & Test Distance: Horizontal at 3 m										
Frequency (MHz)	Emission Level (dBuV/m)	Read Level (dBuV)	Limit (dBuV/m)	Margin (dB)	Antenna Factor (dB/m)	Cable Loss (dB)	Preamp Factor (dB)	Antenna Height (cm)	Table Angle (Degree)	Remark
5046	38.26	38.12	54	-15.74	31.24	6.15	37.25	101	54	Average
5046	60.29	60.15	74	-13.71	31.24	6.15	37.25	101	54	Peak
5220	93.91	93.66			31.37	6.24	37.36	101	54	Average
5220	104.09	103.84			31.37	6.24	37.36	101	54	Peak
5432	38.35	37.61	54	-15.65	31.55	6.32	37.13	101	54	Average
5432	60.47	59.73	74	-13.53	31.55	6.32	37.13	101	54	Peak
Antenna Polarity & Test Distance: Vertical at 3 m										
Frequency (MHz)	Emission Level (dBuV/m)	Read Level (dBuV)	Limit (dBuV/m)	Margin (dB)	Antenna Factor (dB/m)	Cable Loss (dB)	Preamp Factor (dB)	Antenna Height (cm)	Table Angle (Degree)	Remark
5102	38.19	38	54	-15.81	31.28	6.19	37.28	107	353	Average
5102	59.49	59.3	74	-14.51	31.28	6.19	37.28	107	353	Peak
5220	91.82	91.57			31.37	6.24	37.36	107	353	Average
5220	102.01	101.76			31.37	6.24	37.36	107	353	Peak
5460	38.33	37.51	54	-15.67	31.56	6.34	37.08	107	353	Average
5460	60.34	59.52	74	-13.66	31.56	6.34	37.08	107	353	Peak

Remarks:

- Emission Level = Read Level + Antenna Factor + Cable Loss - Preamp Factor  
Margin value = Emission level – Limit value
- 5220 MHz: Fundamental Frequency

EUT Test Condition		Measurement Detail	
Channel	Channel 48	Frequency Range	1 GHz ~ 40 GHz
Input Power	120 Vac, 60 Hz	Detector Function	Peak (PK) Average (AV)
Environmental Conditions	25 deg. C, 65 % RH	Tested By	Toby Tian

Antenna Polarity & Test Distance: Horizontal at 3 m										
Frequency (MHz)	Emission Level (dBuV/m)	Read Level (dBuV)	Limit (dBuV/m)	Margin (dB)	Antenna Factor (dB/m)	Cable Loss (dB)	Preamp Factor (dB)	Antenna Height (cm)	Table Angle (Degree)	Remark
5078	38.22	38.05	54	-15.78	31.27	6.17	37.27	101	48	Average
5078	60.45	60.28	74	-13.55	31.27	6.17	37.27	101	48	Peak
5240	94.05	93.73			31.39	6.25	37.32	101	48	Average
5240	104.32	104			31.39	6.25	37.32	101	48	Peak
5454	38.24	37.42	54	-15.76	31.56	6.34	37.08	101	48	Average
5454	60.37	59.55	74	-13.63	31.56	6.34	37.08	101	48	Peak
Antenna Polarity & Test Distance: Vertical at 3 m										
Frequency (MHz)	Emission Level (dBuV/m)	Read Level (dBuV)	Limit (dBuV/m)	Margin (dB)	Antenna Factor (dB/m)	Cable Loss (dB)	Preamp Factor (dB)	Antenna Height (cm)	Table Angle (Degree)	Remark
5044	37.91	37.77	54	-16.09	31.24	6.15	37.25	100	339	Average
5044	59.9	59.76	74	-14.1	31.24	6.15	37.25	100	339	Peak
5240	91.91	91.59			31.39	6.25	37.32	100	339	Average
5240	102.44	102.12			31.39	6.25	37.32	100	339	Peak
5354	38.05	37.46	54	-15.95	31.48	6.29	37.18	100	339	Average
5354	59.97	59.38	74	-14.03	31.48	6.29	37.18	100	339	Peak

Remarks:

- Emission Level = Read Level + Antenna Factor + Cable Loss - Preamp Factor  
Margin value = Emission level – Limit value
- 5240 MHz: Fundamental Frequency

EUT Test Condition		Measurement Detail	
Channel	Channel 52	Frequency Range	1 GHz ~ 40 GHz
Input Power	120 Vac, 60 Hz	Detector Function	Peak (PK) Average (AV)
Environmental Conditions	25 deg. C, 65 % RH	Tested By	Toby Tian

Antenna Polarity & Test Distance: Horizontal at 3 m										
Frequency (MHz)	Emission Level (dBuV/m)	Read Level (dBuV)	Limit (dBuV/m)	Margin (dB)	Antenna Factor (dB/m)	Cable Loss (dB)	Preamp Factor (dB)	Antenna Height (cm)	Table Angle (Degree)	Remark
5048	38.55	38.41	54	-15.45	31.24	6.15	37.25	198	69	Average
5048	60	59.86	74	-14	31.24	6.15	37.25	198	69	Peak
5260	95.25	94.86			31.41	6.25	37.27	198	69	Average
5260	105.13	104.74			31.41	6.25	37.27	198	69	Peak
5460	38.4	37.58	54	-15.6	31.56	6.34	37.08	198	69	Average
5460	60.92	60.1	74	-13.08	31.56	6.34	37.08	198	69	Peak
Antenna Polarity & Test Distance: Vertical at 3 m										
Frequency (MHz)	Emission Level (dBuV/m)	Read Level (dBuV)	Limit (dBuV/m)	Margin (dB)	Antenna Factor (dB/m)	Cable Loss (dB)	Preamp Factor (dB)	Antenna Height (cm)	Table Angle (Degree)	Remark
5106	38.45	38.25	54	-15.55	31.29	6.19	37.28	187	314	Average
5106	60.1	59.9	74	-13.9	31.29	6.19	37.28	187	314	Peak
5260	93.41	93.02			31.41	6.25	37.27	187	314	Average
5260	103.47	103.08			31.41	6.25	37.27	187	314	Peak
5424	38.23	37.56	54	-15.77	31.53	6.32	37.18	187	314	Average
5424	60.07	59.4	74	-13.93	31.53	6.32	37.18	187	314	Peak

Remarks:

- Emission Level = Read Level + Antenna Factor + Cable Loss - Preamp Factor  
Margin value = Emission level – Limit value
- 5260 MHz: Fundamental Frequency

EUT Test Condition		Measurement Detail	
Channel	Channel 60	Frequency Range	1 GHz ~ 40 GHz
Input Power	120 Vac, 60 Hz	Detector Function	Peak (PK) Average (AV)
Environmental Conditions	25 deg. C, 65 % RH	Tested By	Toby Tian

Antenna Polarity & Test Distance: Horizontal at 3 m										
Frequency (MHz)	Emission Level (dBuV/m)	Read Level (dBuV)	Limit (dBuV/m)	Margin (dB)	Antenna Factor (dB/m)	Cable Loss (dB)	Preamp Factor (dB)	Antenna Height (cm)	Table Angle (Degree)	Remark
5034	38.46	38.32	54	-15.54	31.23	6.15	37.24	200	62	Average
5034	60.76	60.62	74	-13.24	31.23	6.15	37.24	200	62	Peak
5300	94.99	94.47			31.44	6.27	37.19	200	62	Average
5300	104.96	104.44			31.44	6.27	37.19	200	62	Peak
5400	39.33	38.67	54	-14.67	31.52	6.32	37.18	200	62	Average
5400	59.53	58.87	74	-14.47	31.52	6.32	37.18	200	62	Peak
Antenna Polarity & Test Distance: Vertical at 3 m										
Frequency (MHz)	Emission Level (dBuV/m)	Read Level (dBuV)	Limit (dBuV/m)	Margin (dB)	Antenna Factor (dB/m)	Cable Loss (dB)	Preamp Factor (dB)	Antenna Height (cm)	Table Angle (Degree)	Remark
5076	38.38	38.21	54	-15.62	31.27	6.17	37.27	177	335	Average
5076	59.93	59.76	74	-14.07	31.27	6.17	37.27	177	335	Peak
5300	93.03	92.51			31.44	6.27	37.19	177	335	Average
5300	103.41	102.89			31.44	6.27	37.19	177	335	Peak
5350	38.52	37.93	54	-15.48	31.48	6.29	37.18	177	335	Average
5350	60.28	59.69	74	-13.72	31.48	6.29	37.18	177	335	Peak

Remarks:

- Emission Level = Read Level + Antenna Factor + Cable Loss - Preamp Factor  
Margin value = Emission level – Limit value
- 5300 MHz: Fundamental Frequency

EUT Test Condition		Measurement Detail	
Channel	Channel 64	Frequency Range	1 GHz ~ 40 GHz
Input Power	120 Vac, 60 Hz	Detector Function	Peak (PK) Average (AV)
Environmental Conditions	25 deg. C, 65 % RH	Tested By	Toby Tian

Antenna Polarity & Test Distance: Horizontal at 3 m										
Frequency (MHz)	Emission Level (dBuV/m)	Read Level (dBuV)	Limit (dBuV/m)	Margin (dB)	Antenna Factor (dB/m)	Cable Loss (dB)	Preamp Factor (dB)	Antenna Height (cm)	Table Angle (Degree)	Remark
5028	38.5	38.36	54	-15.5	31.23	6.15	37.24	190	61	Average
5028	60.44	60.3	74	-13.56	31.23	6.15	37.24	190	61	Peak
5320	95.41	94.86			31.45	6.29	37.19	190	61	Average
5320	105.06	104.51			31.45	6.29	37.19	190	61	Peak
5450	45.1	44.28	54	-8.9	31.56	6.34	37.08	190	61	Average
5450	60.94	60.12	74	-13.06	31.56	6.34	37.08	190	61	Peak
Antenna Polarity & Test Distance: Vertical at 3 m										
Frequency (MHz)	Emission Level (dBuV/m)	Read Level (dBuV)	Limit (dBuV/m)	Margin (dB)	Antenna Factor (dB/m)	Cable Loss (dB)	Preamp Factor (dB)	Antenna Height (cm)	Table Angle (Degree)	Remark
5110	38.46	38.26	54	-15.54	31.29	6.19	37.28	175	321	Average
5110	59.53	59.33	74	-14.47	31.29	6.19	37.28	175	321	Peak
5320	93.14	92.59			31.45	6.29	37.19	175	321	Average
5320	103.46	102.91			31.45	6.29	37.19	175	321	Peak
5434	43.96	43.22	54	-10.04	31.55	6.32	37.13	175	321	Average
5434	60.61	59.87	74	-13.39	31.55	6.32	37.13	175	321	Peak

Remarks:

- Emission Level = Read Level + Antenna Factor + Cable Loss - Preamp Factor  
Margin value = Emission level – Limit value
- 5320 MHz: Fundamental Frequency

EUT Test Condition		Measurement Detail	
Channel	Channel 100	Frequency Range	1 GHz ~ 40 GHz
Input Power	120 Vac, 60 Hz	Detector Function	Peak (PK) Average (AV)
Environmental Conditions	25 deg. C, 65 % RH	Tested By	Toby Tian

Antenna Polarity & Test Distance: Horizontal at 3 m										
Frequency (MHz)	Emission Level (dBuV/m)	Read Level (dBuV)	Limit (dBuV/m)	Margin (dB)	Antenna Factor (dB/m)	Cable Loss (dB)	Preamp Factor (dB)	Antenna Height (cm)	Table Angle (Degree)	Remark
5438	40.59	39.83	54	-13.41	31.55	6.34	37.13	190	65	Average
5438	59.03	58.27	74	-14.97	31.55	6.34	37.13	190	65	Peak
5470	60.36	59.53	68.2	-7.84	31.57	6.34	37.08	190	65	Peak
5500	93.82	92.89			31.6	6.36	37.03	190	65	Average
5500	105	104.07			31.6	6.36	37.03	190	65	Peak
5725	59.85	58.57	68.2	-8.35	31.96	6.75	37.43	190	65	Peak
Antenna Polarity & Test Distance: Vertical at 3 m										
Frequency (MHz)	Emission Level (dBuV/m)	Read Level (dBuV)	Limit (dBuV/m)	Margin (dB)	Antenna Factor (dB/m)	Cable Loss (dB)	Preamp Factor (dB)	Antenna Height (cm)	Table Angle (Degree)	Remark
5400	39.52	38.86	54	-14.48	31.52	6.32	37.18	184	350	Average
5400	59.6	58.94	74	-14.4	31.52	6.32	37.18	184	350	Peak
5470	59.54	58.71	68.2	-8.66	31.57	6.34	37.08	184	350	Peak
5500	92.16	91.23			31.6	6.36	37.03	184	350	Average
5500	102.77	101.84			31.6	6.36	37.03	184	350	Peak
5725	60.04	58.76	68.2	-8.16	31.96	6.75	37.43	184	350	Peak

Remarks:

- Emission Level = Read Level + Antenna Factor + Cable Loss - Preamp Factor  
Margin value = Emission level – Limit value
- 5500 MHz: Fundamental Frequency
- 5470 MHz & 5725 MHz: Out of Restricted Band

EUT Test Condition		Measurement Detail	
Channel	Channel 116	Frequency Range	1 GHz ~ 40 GHz
Input Power	120 Vac, 60 Hz	Detector Function	Peak (PK) Average (AV)
Environmental Conditions	25 deg. C, 65 % RH	Tested By	Toby Tian

Antenna Polarity & Test Distance: Horizontal at 3 m										
Frequency (MHz)	Emission Level (dBuV/m)	Read Level (dBuV)	Limit (dBuV/m)	Margin (dB)	Antenna Factor (dB/m)	Cable Loss (dB)	Preamp Factor (dB)	Antenna Height (cm)	Table Angle (Degree)	Remark
5400	38.52	37.86	54	-15.48	31.52	6.32	37.18	182	76	Average
5400	60.88	60.22	74	-13.12	31.52	6.32	37.18	182	76	Peak
5470	58.2	57.37	68.2	-10	31.57	6.34	37.08	182	76	Peak
5580	94.12	93.08			31.71	6.49	37.16	182	76	Average
5580	105.2	104.16			31.71	6.49	37.16	182	76	Peak
5725	59.36	58.08	68.2	-8.84	31.96	6.75	37.43	182	76	Peak
Antenna Polarity & Test Distance: Vertical at 3 m										
Frequency (MHz)	Emission Level (dBuV/m)	Read Level (dBuV)	Limit (dBuV/m)	Margin (dB)	Antenna Factor (dB/m)	Cable Loss (dB)	Preamp Factor (dB)	Antenna Height (cm)	Table Angle (Degree)	Remark
5392	38.36	37.72	54	-15.64	31.51	6.31	37.18	206	358	Average
5392	59.43	58.79	74	-14.57	31.51	6.31	37.18	206	358	Peak
5470	58.39	57.56	68.2	-9.81	31.57	6.34	37.08	206	358	Peak
5580	92.45	91.41			31.71	6.49	37.16	206	358	Average
5580	102.82	101.78			31.71	6.49	37.16	206	358	Peak
5725	58.41	57.13	68.2	-9.79	31.96	6.75	37.43	206	358	Peak

Remarks:

- Emission Level = Read Level + Antenna Factor + Cable Loss - Preamp Factor  
Margin value = Emission level – Limit value
- 5580 MHz: Fundamental Frequency
- 5470 MHz & 5725 MHz: Out of Restricted Band



EUT Test Condition		Measurement Detail	
Channel	Channel 140	Frequency Range	1 GHz ~ 40 GHz
Input Power	120 Vac, 60 Hz	Detector Function	Peak (PK) Average (AV)
Environmental Conditions	25 deg. C, 65 % RH	Tested By	Toby Tian

Antenna Polarity & Test Distance: Horizontal at 3 m										
Frequency (MHz)	Emission Level (dBuV/m)	Read Level (dBuV)	Limit (dBuV/m)	Margin (dB)	Antenna Factor (dB/m)	Cable Loss (dB)	Preamp Factor (dB)	Antenna Height (cm)	Table Angle (Degree)	Remark
5436	38.39	37.65	54	-15.61	31.55	6.32	37.13	213	92	Average
5436	60.24	59.5	74	-13.76	31.55	6.32	37.13	213	92	Peak
5470	59.14	58.31	68.2	-9.06	31.57	6.34	37.08	213	92	Peak
5700	93.86	92.67			31.9	6.69	37.4	213	92	Average
5700	104.77	103.58			31.9	6.69	37.4	213	92	Peak
5725	61.85	60.57	68.2	-6.35	31.96	6.75	37.43	213	92	Peak
Antenna Polarity & Test Distance: Vertical at 3 m										
Frequency (MHz)	Emission Level (dBuV/m)	Read Level (dBuV)	Limit (dBuV/m)	Margin (dB)	Antenna Factor (dB/m)	Cable Loss (dB)	Preamp Factor (dB)	Antenna Height (cm)	Table Angle (Degree)	Remark
5410	38.26	37.6	54	-15.74	31.52	6.32	37.18	201	347	Average
5410	59.6	58.94	74	-14.4	31.52	6.32	37.18	201	347	Peak
5470	57.49	56.66	68.2	-10.71	31.57	6.34	37.08	201	347	Peak
5700	92.23	91.04			31.9	6.69	37.4	201	347	Average
5700	102.62	101.43			31.9	6.69	37.4	201	347	Peak
5725	61.22	59.94	68.2	-6.98	31.96	6.75	37.43	201	347	Peak

Remarks:

- Emission Level = Read Level + Antenna Factor + Cable Loss - Preamp Factor  
Margin value = Emission level – Limit value
- 5700 MHz: Fundamental Frequency
- 5470 MHz & 5725 MHz: Out of Restricted Band

EUT Test Condition		Measurement Detail	
Channel	Channel 149	Frequency Range	1 GHz ~ 40 GHz
Input Power	120 Vac, 60 Hz	Detector Function	Peak (PK) Average (AV)
Environmental Conditions	25 deg. C, 65 % RH	Tested By	Gavin Wu

Antenna Polarity & Test Distance: Horizontal at 3 m										
Frequency (MHz)	Emission Level (dBuV/m)	Read Level (dBuV)	Limit (dBuV/m)	Margin (dB)	Antenna Factor (dB/m)	Cable Loss (dB)	Preamp Factor (dB)	Antenna Height (cm)	Table Angle (Degree)	Remark
*5714	60.22	59.03	68.2	-7.98	31.93	6.69	37.43	194	96	Peak
*5725	64.79	63.51	78.2	-13.41	31.96	6.75	37.43	194	96	Peak
5745	93.86	92.59			31.99	6.75	37.47	194	96	Average
5745	105.49	104.22			31.99	6.75	37.47	194	96	Peak
*5850	59.36	57.84	78.2	-18.84	32.15	6.88	37.51	194	96	Peak
*5861	59.91	58.28	68.2	-8.29	32.18	6.95	37.5	194	96	Peak
Antenna Polarity & Test Distance: Vertical at 3 m										
Frequency (MHz)	Emission Level (dBuV/m)	Read Level (dBuV)	Limit (dBuV/m)	Margin (dB)	Antenna Factor (dB/m)	Cable Loss (dB)	Preamp Factor (dB)	Antenna Height (cm)	Table Angle (Degree)	Remark
*5714	58.42	57.23	68.2	-9.78	31.93	6.69	37.43	182	29	Peak
*5725	63.72	62.44	78.2	-14.48	31.96	6.75	37.43	182	29	Peak
5745	89.51	88.24			31.99	6.75	37.47	182	29	Average
5745	100.85	99.58			31.99	6.75	37.47	182	29	Peak
*5850	59.79	58.27	78.2	-18.41	32.15	6.88	37.51	182	29	Peak
*5861	59.46	57.83	68.2	-8.74	32.18	6.95	37.5	182	29	Peak

Remarks:

- Emission Level = Read Level + Antenna Factor + Cable Loss - Preamp Factor  
Margin value = Emission level – Limit value
- 5745 MHz: Fundamental Frequency
- \*: Out of Restricted Band

EUT Test Condition		Measurement Detail	
Channel	Channel 157	Frequency Range	1 GHz ~ 40 GHz
Input Power	120 Vac, 60 Hz	Detector Function	Peak (PK) Average (AV)
Environmental Conditions	25 deg. C, 65 % RH	Tested By	Gavin Wu

Antenna Polarity & Test Distance: Horizontal at 3 m										
Frequency (MHz)	Emission Level (dBuV/m)	Read Level (dBuV)	Limit (dBuV/m)	Margin (dB)	Antenna Factor (dB/m)	Cable Loss (dB)	Preamp Factor (dB)	Antenna Height (cm)	Table Angle (Degree)	Remark
*5714	59.08	57.89	68.2	-9.12	31.93	6.69	37.43	189	94	Peak
*5725	58.58	57.3	78.2	-19.62	31.96	6.75	37.43	189	94	Peak
5785	93.69	92.37			32.04	6.82	37.54	189	94	Average
5785	105.74	104.42			32.04	6.82	37.54	189	94	Peak
*5850	58.89	57.37	78.2	-19.31	32.15	6.88	37.51	189	94	Peak
*5861	59.28	57.65	68.2	-8.92	32.18	6.95	37.5	189	94	Peak

Antenna Polarity & Test Distance: Vertical at 3 m										
Frequency (MHz)	Emission Level (dBuV/m)	Read Level (dBuV)	Limit (dBuV/m)	Margin (dB)	Antenna Factor (dB/m)	Cable Loss (dB)	Preamp Factor (dB)	Antenna Height (cm)	Table Angle (Degree)	Remark
*5714	58.68	57.49	68.2	-9.52	31.93	6.69	37.43	180	15	Peak
*5725	59.4	58.12	78.2	-18.8	31.96	6.75	37.43	180	15	Peak
5785	89.04	87.72			32.04	6.82	37.54	180	15	Average
5785	100.94	99.62			32.04	6.82	37.54	180	15	Peak
*5850	59.08	57.56	78.2	-19.12	32.15	6.88	37.51	180	15	Peak
*5861	61.14	59.51	68.2	-7.06	32.18	6.95	37.5	180	15	Peak

Remarks:

- Emission Level = Read Level + Antenna Factor + Cable Loss - Preamp Factor  
Margin value = Emission level – Limit value
- 5785 MHz: Fundamental Frequency
- \*: Out of Restricted Band

EUT Test Condition		Measurement Detail	
Channel	Channel 165	Frequency Range	1 GHz ~ 40 GHz
Input Power	120 Vac, 60 Hz	Detector Function	Peak (PK) Average (AV)
Environmental Conditions	25 deg. C, 65 % RH	Tested By	Gavin Wu

Antenna Polarity & Test Distance: Horizontal at 3 m										
Frequency (MHz)	Emission Level (dBuV/m)	Read Level (dBuV)	Limit (dBuV/m)	Margin (dB)	Antenna Factor (dB/m)	Cable Loss (dB)	Preamp Factor (dB)	Antenna Height (cm)	Table Angle (Degree)	Remark
*5714	58.87	57.68	68.2	-9.33	31.93	6.69	37.43	182	93	Peak
*5725	59.62	58.34	78.2	-18.58	31.96	6.75	37.43	182	93	Peak
5825	93.95	92.48			32.12	6.88	37.53	182	93	Average
5825	105.53	104.06			32.12	6.88	37.53	182	93	Peak
*5850	63.83	62.31	78.2	-14.37	32.15	6.88	37.51	182	93	Peak
*5861	59.88	58.25	68.2	-8.32	32.18	6.95	37.5	182	93	Peak
Antenna Polarity & Test Distance: Vertical at 3 m										
Frequency (MHz)	Emission Level (dBuV/m)	Read Level (dBuV)	Limit (dBuV/m)	Margin (dB)	Antenna Factor (dB/m)	Cable Loss (dB)	Preamp Factor (dB)	Antenna Height (cm)	Table Angle (Degree)	Remark
*5714	58.68	57.49	68.2	-9.52	31.93	6.69	37.43	187	13	Peak
*5725	59.84	58.56	78.2	-18.36	31.96	6.75	37.43	187	13	Peak
5825	89.69	88.22			32.12	6.88	37.53	187	13	Average
5825	100.95	99.48			32.12	6.88	37.53	187	13	Peak
*5850	61.62	60.1	78.2	-16.58	32.15	6.88	37.51	187	13	Peak
*5861	59.85	58.22	68.2	-8.35	32.18	6.95	37.5	187	13	Peak

Remarks:

- Emission Level = Read Level + Antenna Factor + Cable Loss - Preamp Factor  
Margin value = Emission level – Limit value
- 5825 MHz: Fundamental Frequency
- \*: Out of Restricted Band

### 802.11n (HT20)

EUT Test Condition		Measurement Detail	
Channel	Channel 36	Frequency Range	1 GHz ~ 40 GHz
Input Power	120 Vac, 60 Hz	Detector Function	Peak (PK) Average (AV)
Environmental Conditions	25 deg. C, 65 % RH	Tested By	Toby Tian

#### Antenna Polarity & Test Distance: Horizontal at 3 m

Frequency (MHz)	Emission Level (dBuV/m)	Read Level (dBuV)	Limit (dBuV/m)	Margin (dB)	Antenna Factor (dB/m)	Cable Loss (dB)	Preamp Factor (dB)	Antenna Height (cm)	Table Angle (Degree)	Remark
5074	39.47	39.3	54	-14.53	31.27	6.17	37.27	101	71	Average
5074	59.89	59.72	74	-14.11	31.27	6.17	37.27	101	71	Peak
5180	89.22	88.99			31.35	6.22	37.34	101	71	Average
5180	99.77	99.54			31.35	6.22	37.34	101	71	Peak
5356	38.29	37.7	54	-15.71	31.48	6.29	37.18	101	71	Average
5356	60.42	59.83	74	-13.58	31.48	6.29	37.18	101	71	Peak

#### Antenna Polarity & Test Distance: Vertical at 3 m

Frequency (MHz)	Emission Level (dBuV/m)	Read Level (dBuV)	Limit (dBuV/m)	Margin (dB)	Antenna Factor (dB/m)	Cable Loss (dB)	Preamp Factor (dB)	Antenna Height (cm)	Table Angle (Degree)	Remark
5032	39.21	39.07	54	-14.79	31.23	6.15	37.24	100	344	Average
5032	59.71	59.57	74	-14.29	31.23	6.15	37.24	100	344	Peak
5180	87.75	87.52			31.35	6.22	37.34	100	344	Average
5180	97.9	97.67			31.35	6.22	37.34	100	344	Peak
5360	38.21	37.6	54	-15.79	31.48	6.31	37.18	100	344	Average
5360	59.43	58.82	74	-14.57	31.48	6.31	37.18	100	344	Peak

Remarks:

- Emission Level = Read Level + Antenna Factor + Cable Loss - Preamp Factor  
Margin value = Emission level – Limit value
- 5180 MHz: Fundamental Frequency

EUT Test Condition		Measurement Detail	
Channel	Channel 44	Frequency Range	1 GHz ~ 40 GHz
Input Power	120 Vac, 60 Hz	Detector Function	Peak (PK) Average (AV)
Environmental Conditions	25 deg. C, 65 % RH	Tested By	Toby Tian

Antenna Polarity & Test Distance: Horizontal at 3 m										
Frequency (MHz)	Emission Level (dBuV/m)	Read Level (dBuV)	Limit (dBuV/m)	Margin (dB)	Antenna Factor (dB/m)	Cable Loss (dB)	Preamp Factor (dB)	Antenna Height (cm)	Table Angle (Degree)	Remark
5088	38.02	37.83	54	-15.98	31.27	6.19	37.27	101	67	Average
5088	59.28	59.09	74	-14.72	31.27	6.19	37.27	101	67	Peak
5220	88.92	88.67			31.37	6.24	37.36	101	67	Average
5220	99.59	99.34			31.37	6.24	37.36	101	67	Peak
5350	38.28	37.69	54	-15.72	31.48	6.29	37.18	101	67	Average
5350	60.57	59.98	74	-13.43	31.48	6.29	37.18	101	67	Peak
Antenna Polarity & Test Distance: Vertical at 3 m										
Frequency (MHz)	Emission Level (dBuV/m)	Read Level (dBuV)	Limit (dBuV/m)	Margin (dB)	Antenna Factor (dB/m)	Cable Loss (dB)	Preamp Factor (dB)	Antenna Height (cm)	Table Angle (Degree)	Remark
5100	38.03	37.84	54	-15.97	31.28	6.19	37.28	107	346	Average
5100	59.34	59.15	74	-14.66	31.28	6.19	37.28	107	346	Peak
5220	87.05	86.8			31.37	6.24	37.36	107	346	Average
5220	97.45	97.2			31.37	6.24	37.36	107	346	Peak
5440	38.23	37.47	54	-15.77	31.55	6.34	37.13	107	346	Average
5440	60.72	59.96	74	-13.28	31.55	6.34	37.13	107	346	Peak

Remarks:

- Emission Level = Read Level + Antenna Factor + Cable Loss - Preamp Factor  
Margin value = Emission level – Limit value
- 5220 MHz: Fundamental Frequency

EUT Test Condition		Measurement Detail	
Channel	Channel 48	Frequency Range	1 GHz ~ 40 GHz
Input Power	120 Vac, 60 Hz	Detector Function	Peak (PK) Average (AV)
Environmental Conditions	25 deg. C, 65 % RH	Tested By	Toby Tian

Antenna Polarity & Test Distance: Horizontal at 3 m										
Frequency (MHz)	Emission Level (dBuV/m)	Read Level (dBuV)	Limit (dBuV/m)	Margin (dB)	Antenna Factor (dB/m)	Cable Loss (dB)	Preamp Factor (dB)	Antenna Height (cm)	Table Angle (Degree)	Remark
5024	38.02	37.88	54	-15.98	31.23	6.15	37.24	102	74	Average
5024	60.26	60.12	74	-13.74	31.23	6.15	37.24	102	74	Peak
5240	89.3	88.98			31.39	6.25	37.32	102	74	Average
5240	99.73	99.41			31.39	6.25	37.32	102	74	Peak
5356	38.18	37.59	54	-15.82	31.48	6.29	37.18	102	74	Average
5356	61.02	60.43	74	-12.98	31.48	6.29	37.18	102	74	Peak

Antenna Polarity & Test Distance: Vertical at 3 m										
Frequency (MHz)	Emission Level (dBuV/m)	Read Level (dBuV)	Limit (dBuV/m)	Margin (dB)	Antenna Factor (dB/m)	Cable Loss (dB)	Preamp Factor (dB)	Antenna Height (cm)	Table Angle (Degree)	Remark
5106	38.05	37.85	54	-15.95	31.29	6.19	37.28	100	329	Average
5106	60.26	60.06	74	-13.74	31.29	6.19	37.28	100	329	Peak
5240	87.46	87.14			31.39	6.25	37.32	100	329	Average
5240	97.7	97.38			31.39	6.25	37.32	100	329	Peak
5460	38.26	37.44	54	-15.74	31.56	6.34	37.08	100	329	Average
5460	59.88	59.06	74	-14.12	31.56	6.34	37.08	100	329	Peak

Remarks:

- Emission Level = Read Level + Antenna Factor + Cable Loss - Preamp Factor  
Margin value = Emission level – Limit value
- 5240 MHz: Fundamental Frequency

EUT Test Condition		Measurement Detail	
Channel	Channel 52	Frequency Range	1 GHz ~ 40 GHz
Input Power	120 Vac, 60 Hz	Detector Function	Peak (PK) Average (AV)
Environmental Conditions	25 deg. C, 65 % RH	Tested By	Toby Tian

Antenna Polarity & Test Distance: Horizontal at 3 m										
Frequency (MHz)	Emission Level (dBuV/m)	Read Level (dBuV)	Limit (dBuV/m)	Margin (dB)	Antenna Factor (dB/m)	Cable Loss (dB)	Preamp Factor (dB)	Antenna Height (cm)	Table Angle (Degree)	Remark
5138	38.17	37.96	54	-15.83	31.31	6.2	37.3	175	70	Average
5138	60.38	60.17	74	-13.62	31.31	6.2	37.3	175	70	Peak
5260	90.5	90.11			31.41	6.25	37.27	175	70	Average
5260	100.59	100.2			31.41	6.25	37.27	175	70	Peak
5392	38.31	37.67	54	-15.69	31.51	6.31	37.18	175	70	Average
5392	60.22	59.58	74	-13.78	31.51	6.31	37.18	175	70	Peak
Antenna Polarity & Test Distance: Vertical at 3 m										
Frequency (MHz)	Emission Level (dBuV/m)	Read Level (dBuV)	Limit (dBuV/m)	Margin (dB)	Antenna Factor (dB/m)	Cable Loss (dB)	Preamp Factor (dB)	Antenna Height (cm)	Table Angle (Degree)	Remark
5102	38.07	37.88	54	-15.93	31.28	6.19	37.28	188	318	Average
5102	60.32	60.13	74	-13.68	31.28	6.19	37.28	188	318	Peak
5260	89.03	88.64			31.41	6.25	37.27	188	318	Average
5260	99.11	98.72			31.41	6.25	37.27	188	318	Peak
5392	38.24	37.6	54	-15.76	31.51	6.31	37.18	188	318	Average
5392	61.77	61.13	74	-12.23	31.51	6.31	37.18	188	318	Peak

Remarks:

- Emission Level = Read Level + Antenna Factor + Cable Loss - Preamp Factor  
Margin value = Emission level – Limit value
- 5260 MHz: Fundamental Frequency



EUT Test Condition		Measurement Detail	
Channel	Channel 60	Frequency Range	1 GHz ~ 40 GHz
Input Power	120 Vac, 60 Hz	Detector Function	Peak (PK) Average (AV)
Environmental Conditions	25 deg. C, 65 % RH	Tested By	Toby Tian

Antenna Polarity & Test Distance: Horizontal at 3 m										
Frequency (MHz)	Emission Level (dBuV/m)	Read Level (dBuV)	Limit (dBuV/m)	Margin (dB)	Antenna Factor (dB/m)	Cable Loss (dB)	Preamp Factor (dB)	Antenna Height (cm)	Table Angle (Degree)	Remark
5064	38.11	37.94	54	-15.89	31.25	6.17	37.25	208	54	Average
5064	60.17	60	74	-13.83	31.25	6.17	37.25	208	54	Peak
5300	90.73	90.21			31.44	6.27	37.19	208	54	Average
5300	100.56	100.04			31.44	6.27	37.19	208	54	Peak
5388	38.56	37.92	54	-15.44	31.51	6.31	37.18	208	54	Average
5388	60.67	60.03	74	-13.33	31.51	6.31	37.18	208	54	Peak
Antenna Polarity & Test Distance: Vertical at 3 m										
Frequency (MHz)	Emission Level (dBuV/m)	Read Level (dBuV)	Limit (dBuV/m)	Margin (dB)	Antenna Factor (dB/m)	Cable Loss (dB)	Preamp Factor (dB)	Antenna Height (cm)	Table Angle (Degree)	Remark
5096	38.13	37.94	54	-15.87	31.28	6.19	37.28	177	312	Average
5096	60.68	60.49	74	-13.32	31.28	6.19	37.28	177	312	Peak
5300	88.65	88.13			31.44	6.27	37.19	177	312	Average
5300	99.09	98.57			31.44	6.27	37.19	177	312	Peak
5430	38.31	37.57	54	-15.69	31.55	6.32	37.13	177	312	Average
5430	59.92	59.18	74	-14.08	31.55	6.32	37.13	177	312	Peak

Remarks:

- Emission Level = Read Level + Antenna Factor + Cable Loss - Preamp Factor  
Margin value = Emission level – Limit value
- 5300 MHz: Fundamental Frequency

EUT Test Condition		Measurement Detail	
Channel	Channel 64	Frequency Range	1 GHz ~ 40 GHz
Input Power	120 Vac, 60 Hz	Detector Function	Peak (PK) Average (AV)
Environmental Conditions	25 deg. C, 65 % RH	Tested By	Toby Tian

Antenna Polarity & Test Distance: Horizontal at 3 m										
Frequency (MHz)	Emission Level (dBuV/m)	Read Level (dBuV)	Limit (dBuV/m)	Margin (dB)	Antenna Factor (dB/m)	Cable Loss (dB)	Preamp Factor (dB)	Antenna Height (cm)	Table Angle (Degree)	Remark
5128	38.13	37.92	54	-15.87	31.31	6.2	37.3	189	57	Average
5128	60.39	60.18	74	-13.61	31.31	6.2	37.3	189	57	Peak
5320	90.23	89.68			31.45	6.29	37.19	189	57	Average
5320	100.72	100.17			31.45	6.29	37.19	189	57	Peak
5430	39.91	39.17	54	-14.09	31.55	6.32	37.13	189	57	Average
5430	60.95	60.21	74	-13.05	31.55	6.32	37.13	189	57	Peak
Antenna Polarity & Test Distance: Vertical at 3 m										
Frequency (MHz)	Emission Level (dBuV/m)	Read Level (dBuV)	Limit (dBuV/m)	Margin (dB)	Antenna Factor (dB/m)	Cable Loss (dB)	Preamp Factor (dB)	Antenna Height (cm)	Table Angle (Degree)	Remark
5072	38.02	37.85	54	-15.98	31.27	6.17	37.27	176	304	Average
5072	59.58	59.41	74	-14.42	31.27	6.17	37.27	176	304	Peak
5320	88.94	88.39			31.45	6.29	37.19	176	304	Average
5320	99.3	98.75			31.45	6.29	37.19	176	304	Peak
5434	38.72	37.98	54	-15.28	31.55	6.32	37.13	176	304	Average
5434	60.13	59.39	74	-13.87	31.55	6.32	37.13	176	304	Peak

Remarks:

- Emission Level = Read Level + Antenna Factor + Cable Loss - Preamp Factor  
Margin value = Emission level – Limit value
- 5320 MHz: Fundamental Frequency

EUT Test Condition		Measurement Detail	
Channel	Channel 100	Frequency Range	1 GHz ~ 40 GHz
Input Power	120 Vac, 60 Hz	Detector Function	Peak (PK) Average (AV)
Environmental Conditions	25 deg. C, 65 % RH	Tested By	Toby Tian

Antenna Polarity & Test Distance: Horizontal at 3 m										
Frequency (MHz)	Emission Level (dBuV/m)	Read Level (dBuV)	Limit (dBuV/m)	Margin (dB)	Antenna Factor (dB/m)	Cable Loss (dB)	Preamp Factor (dB)	Antenna Height (cm)	Table Angle (Degree)	Remark
5458	39	38.18	54	-15	31.56	6.34	37.08	198	58	Average
5458	60.01	59.19	74	-13.99	31.56	6.34	37.08	198	58	Peak
5470	59.89	59.06	68.2	-8.31	31.57	6.34	37.08	198	58	Peak
5500	90.36	89.43			31.6	6.36	37.03	198	58	Average
5500	101.37	100.44			31.6	6.36	37.03	198	58	Peak
5725	59.1	57.82	68.2	-9.1	31.96	6.75	37.43	198	58	Peak
Antenna Polarity & Test Distance: Vertical at 3 m										
Frequency (MHz)	Emission Level (dBuV/m)	Read Level (dBuV)	Limit (dBuV/m)	Margin (dB)	Antenna Factor (dB/m)	Cable Loss (dB)	Preamp Factor (dB)	Antenna Height (cm)	Table Angle (Degree)	Remark
5416	38.43	37.76	54	-15.57	31.53	6.32	37.18	202	336	Average
5416	60.06	59.39	74	-13.94	31.53	6.32	37.18	202	336	Peak
5470	58.84	58.01	68.2	-9.36	31.57	6.34	37.08	202	336	Peak
5500	88.14	87.21			31.6	6.36	37.03	202	336	Average
5500	98.69	97.76			31.6	6.36	37.03	202	336	Peak
5725	59.77	58.49	68.2	-8.43	31.96	6.75	37.43	202	336	Peak

Remarks:

- Emission Level = Read Level + Antenna Factor + Cable Loss - Preamp Factor  
Margin value = Emission level – Limit value
- 5500 MHz: Fundamental Frequency
- 5470 MHz & 5725 MHz: Out of Restricted Band

EUT Test Condition		Measurement Detail	
Channel	Channel 116	Frequency Range	1 GHz ~ 40 GHz
Input Power	120 Vac, 60 Hz	Detector Function	Peak (PK) Average (AV)
Environmental Conditions	25 deg. C, 65 % RH	Tested By	Toby Tian

Antenna Polarity & Test Distance: Horizontal at 3 m										
Frequency (MHz)	Emission Level (dBuV/m)	Read Level (dBuV)	Limit (dBuV/m)	Margin (dB)	Antenna Factor (dB/m)	Cable Loss (dB)	Preamp Factor (dB)	Antenna Height (cm)	Table Angle (Degree)	Remark
5422	38.26	37.59	54	-15.74	31.53	6.32	37.18	193	88	Average
5422	60.27	59.6	74	-13.73	31.53	6.32	37.18	193	88	Peak
5470	58.18	57.35	68.2	-10.02	31.57	6.34	37.08	193	88	Peak
5580	90.55	89.51			31.71	6.49	37.16	193	88	Average
5580	101.51	100.47			31.71	6.49	37.16	193	88	Peak
5725	59.2	57.92	68.2	-9	31.96	6.75	37.43	193	88	Peak
Antenna Polarity & Test Distance: Vertical at 3 m										
Frequency (MHz)	Emission Level (dBuV/m)	Read Level (dBuV)	Limit (dBuV/m)	Margin (dB)	Antenna Factor (dB/m)	Cable Loss (dB)	Preamp Factor (dB)	Antenna Height (cm)	Table Angle (Degree)	Remark
5428	38.12	37.4	54	-15.88	31.53	6.32	37.13	180	340	Average
5428	60.65	59.93	74	-13.35	31.53	6.32	37.13	180	340	Peak
5470	58.87	58.04	68.2	-9.33	31.57	6.34	37.08	180	340	Peak
5580	88.35	87.31			31.71	6.49	37.16	180	340	Average
5580	98.7	97.66			31.71	6.49	37.16	180	340	Peak
5725	59.15	57.87	68.2	-9.05	31.96	6.75	37.43	180	340	Peak

Remarks:

- Emission Level = Read Level + Antenna Factor + Cable Loss - Preamp Factor  
Margin value = Emission level – Limit value
- 5580 MHz: Fundamental Frequency
- 5470 MHz & 5725 MHz: Out of Restricted Band

EUT Test Condition		Measurement Detail	
Channel	Channel 140	Frequency Range	1 GHz ~ 40 GHz
Input Power	120 Vac, 60 Hz	Detector Function	Peak (PK) Average (AV)
Environmental Conditions	25 deg. C, 65 % RH	Tested By	Toby Tian

Antenna Polarity & Test Distance: Horizontal at 3 m										
Frequency (MHz)	Emission Level (dBuV/m)	Read Level (dBuV)	Limit (dBuV/m)	Margin (dB)	Antenna Factor (dB/m)	Cable Loss (dB)	Preamp Factor (dB)	Antenna Height (cm)	Table Angle (Degree)	Remark
5354	38.08	37.49	54	-15.92	31.48	6.29	37.18	201	100	Average
5354	61.24	60.65	74	-12.76	31.48	6.29	37.18	201	100	Peak
5470	58.99	58.16	68.2	-9.21	31.57	6.34	37.08	201	100	Peak
5700	90.72	89.53			31.9	6.69	37.4	201	100	Average
5700	101.18	99.99			31.9	6.69	37.4	201	100	Peak
5725	60.41	59.13	68.2	-7.79	31.96	6.75	37.43	201	100	Peak

Antenna Polarity & Test Distance: Vertical at 3 m										
Frequency (MHz)	Emission Level (dBuV/m)	Read Level (dBuV)	Limit (dBuV/m)	Margin (dB)	Antenna Factor (dB/m)	Cable Loss (dB)	Preamp Factor (dB)	Antenna Height (cm)	Table Angle (Degree)	Remark
5376	38.05	37.43	54	-15.95	31.49	6.31	37.18	192	355	Average
5376	59.38	58.76	74	-14.62	31.49	6.31	37.18	192	355	Peak
5470	57.36	56.53	68.2	-10.84	31.57	6.34	37.08	192	355	Peak
5700	88.55	87.36			31.9	6.69	37.4	192	355	Average
5700	98.66	97.47			31.9	6.69	37.4	192	355	Peak
5725	58.9	57.62	68.2	-9.3	31.96	6.75	37.43	192	355	Peak

Remarks:

- Emission Level = Read Level + Antenna Factor + Cable Loss - Preamp Factor  
Margin value = Emission level – Limit value
- 5700 MHz: Fundamental Frequency
- 5470 MHz & 5725 MHz: Out of Restricted Band

EUT Test Condition		Measurement Detail	
Channel	Channel 149	Frequency Range	1 GHz ~ 40 GHz
Input Power	120 Vac, 60 Hz	Detector Function	Peak (PK) Average (AV)
Environmental Conditions	25 deg. C, 65 % RH	Tested By	Gavin Wu

Antenna Polarity & Test Distance: Horizontal at 3 m										
Frequency (MHz)	Emission Level (dBuV/m)	Read Level (dBuV)	Limit (dBuV/m)	Margin (dB)	Antenna Factor (dB/m)	Cable Loss (dB)	Preamp Factor (dB)	Antenna Height (cm)	Table Angle (Degree)	Remark
*5714	60.23	59.04	68.2	-7.97	31.93	6.69	37.43	158	87	Peak
*5725	64.51	63.23	78.2	-13.69	31.96	6.75	37.43	158	87	Peak
5745	90.57	89.3			31.99	6.75	37.47	158	87	Average
5745	100.77	99.5			31.99	6.75	37.47	158	87	Peak
*5850	59.08	57.56	78.2	-19.12	32.15	6.88	37.51	158	87	Peak
*5861	59.08	57.45	68.2	-9.12	32.18	6.95	37.5	158	87	Peak
Antenna Polarity & Test Distance: Vertical at 3 m										
Frequency (MHz)	Emission Level (dBuV/m)	Read Level (dBuV)	Limit (dBuV/m)	Margin (dB)	Antenna Factor (dB/m)	Cable Loss (dB)	Preamp Factor (dB)	Antenna Height (cm)	Table Angle (Degree)	Remark
*5714	58.37	57.18	68.2	-9.83	31.93	6.69	37.43	207	19	Peak
*5725	59.42	58.14	78.2	-18.78	31.96	6.75	37.43	207	19	Peak
5745	85.61	84.34			31.99	6.75	37.47	207	19	Average
5745	95.33	94.06			31.99	6.75	37.47	207	19	Peak
*5850	59.28	57.76	78.2	-18.92	32.15	6.88	37.51	207	19	Peak
*5861	59.76	58.13	68.2	-8.44	32.18	6.95	37.5	207	19	Peak

Remarks:

- Emission Level = Read Level + Antenna Factor + Cable Loss - Preamp Factor  
Margin value = Emission level – Limit value
- 5745 MHz: Fundamental Frequency
- \*: Out of Restricted Band

EUT Test Condition		Measurement Detail	
Channel	Channel 157	Frequency Range	1 GHz ~ 40 GHz
Input Power	120 Vac, 60 Hz	Detector Function	Peak (PK) Average (AV)
Environmental Conditions	25 deg. C, 65 % RH	Tested By	Gavin Wu

Antenna Polarity & Test Distance: Horizontal at 3 m										
Frequency (MHz)	Emission Level (dBuV/m)	Read Level (dBuV)	Limit (dBuV/m)	Margin (dB)	Antenna Factor (dB/m)	Cable Loss (dB)	Preamp Factor (dB)	Antenna Height (cm)	Table Angle (Degree)	Remark
*5714	58.28	57.09	68.2	-9.92	31.93	6.69	37.43	172	84	Peak
*5725	58.9	57.62	78.2	-19.3	31.96	6.75	37.43	172	84	Peak
5785	90.78	89.46			32.04	6.82	37.54	172	84	Average
5785	100.43	99.11			32.04	6.82	37.54	172	84	Peak
*5850	59.36	57.84	78.2	-18.84	32.15	6.88	37.51	172	84	Peak
*5861	59.93	58.3	68.2	-8.27	32.18	6.95	37.5	172	84	Peak
Antenna Polarity & Test Distance: Vertical at 3 m										
Frequency (MHz)	Emission Level (dBuV/m)	Read Level (dBuV)	Limit (dBuV/m)	Margin (dB)	Antenna Factor (dB/m)	Cable Loss (dB)	Preamp Factor (dB)	Antenna Height (cm)	Table Angle (Degree)	Remark
*5714	58.91	57.72	68.2	-9.29	31.93	6.69	37.43	214	14	Peak
*5725	59.75	58.47	78.2	-18.45	31.96	6.75	37.43	214	14	Peak
5785	85.7	84.38			32.04	6.82	37.54	214	14	Average
5785	96.62	95.3			32.04	6.82	37.54	214	14	Peak
*5850	60.59	59.07	78.2	-17.61	32.15	6.88	37.51	214	14	Peak
*5861	59.29	57.66	68.2	-8.91	32.18	6.95	37.5	214	14	Peak

Remarks:

- Emission Level = Read Level + Antenna Factor + Cable Loss - Preamp Factor  
Margin value = Emission level – Limit value
- 5785 MHz: Fundamental Frequency
- \*: Out of Restricted Band

EUT Test Condition		Measurement Detail	
Channel	Channel 165	Frequency Range	1 GHz ~ 40 GHz
Input Power	120 Vac, 60 Hz	Detector Function	Peak (PK) Average (AV)
Environmental Conditions	25 deg. C, 65 % RH	Tested By	Gavin Wu

Antenna Polarity & Test Distance: Horizontal at 3 m										
Frequency (MHz)	Emission Level (dBuV/m)	Read Level (dBuV)	Limit (dBuV/m)	Margin (dB)	Antenna Factor (dB/m)	Cable Loss (dB)	Preamp Factor (dB)	Antenna Height (cm)	Table Angle (Degree)	Remark
*5714	59.12	57.93	68.2	-9.08	31.93	6.69	37.43	118	84	Peak
*5725	59.22	57.94	78.2	-18.98	31.96	6.75	37.43	118	84	Peak
5825	90.59	89.12			32.12	6.88	37.53	118	84	Average
5825	100.87	99.4			32.12	6.88	37.53	118	84	Peak
*5850	60.15	58.63	78.2	-18.05	32.15	6.88	37.51	118	84	Peak
*5861	59.45	57.82	68.2	-8.75	32.18	6.95	37.5	118	84	Peak
Antenna Polarity & Test Distance: Vertical at 3 m										
Frequency (MHz)	Emission Level (dBuV/m)	Read Level (dBuV)	Limit (dBuV/m)	Margin (dB)	Antenna Factor (dB/m)	Cable Loss (dB)	Preamp Factor (dB)	Antenna Height (cm)	Table Angle (Degree)	Remark
*5714	58.51	57.32	68.2	-9.69	31.93	6.69	37.43	211	14	Peak
*5725	57.97	56.69	78.2	-20.23	31.96	6.75	37.43	211	14	Peak
5825	86.91	85.44			32.12	6.88	37.53	211	14	Average
5825	95.48	94.01			32.12	6.88	37.53	211	14	Peak
*5850	59.65	58.13	78.2	-18.55	32.15	6.88	37.51	211	14	Peak
*5861	59.15	57.52	68.2	-9.05	32.18	6.95	37.5	211	14	Peak

Remarks:

- Emission Level = Read Level + Antenna Factor + Cable Loss - Preamp Factor  
Margin value = Emission level – Limit value
- 5825 MHz: Fundamental Frequency
- \*: Out of Restricted Band



802.11ac (VHT40)

EUT Test Condition		Measurement Detail	
Channel	Channel 38	Frequency Range	1 GHz ~ 40 GHz
Input Power	120 Vac, 60 Hz	Detector Function	Peak (PK) Average (AV)
Environmental Conditions	25 deg. C, 65 % RH	Tested By	Toby Tian

Antenna Polarity & Test Distance: Horizontal at 3 m										
Frequency (MHz)	Emission Level (dBuV/m)	Read Level (dBuV)	Limit (dBuV/m)	Margin (dB)	Antenna Factor (dB/m)	Cable Loss (dB)	Preamp Factor (dB)	Antenna Height (cm)	Table Angle (Degree)	Remark
5138	42	41.79	54	-12	31.31	6.2	37.3	103	66	Average
5138	60.08	59.87	74	-13.92	31.31	6.2	37.3	103	66	Peak
5190	84.65	84.42			31.35	6.22	37.34	103	66	Average
5190	94.85	94.62			31.35	6.22	37.34	103	66	Peak
5424	38.95	38.28	54	-15.05	31.53	6.32	37.18	103	66	Average
5424	61	60.33	74	-13	31.53	6.32	37.18	103	66	Peak

Antenna Polarity & Test Distance: Vertical at 3 m										
Frequency (MHz)	Emission Level (dBuV/m)	Read Level (dBuV)	Limit (dBuV/m)	Margin (dB)	Antenna Factor (dB/m)	Cable Loss (dB)	Preamp Factor (dB)	Antenna Height (cm)	Table Angle (Degree)	Remark
5120	40.53	40.35	54	-13.47	31.29	6.19	37.3	100	335	Average
5120	59.49	59.31	74	-14.51	31.29	6.19	37.3	100	335	Peak
5190	82.62	82.39			31.35	6.22	37.34	100	335	Average
5190	92.77	92.54			31.35	6.22	37.34	100	335	Peak
5432	38.53	37.79	54	-15.47	31.55	6.32	37.13	100	335	Average
5432	60.88	60.14	74	-13.12	31.55	6.32	37.13	100	335	Peak

Remarks:

- Emission Level = Read Level + Antenna Factor + Cable Loss - Preamp Factor  
Margin value = Emission level – Limit value
- 5190 MHz: Fundamental Frequency

EUT Test Condition		Measurement Detail	
Channel	Channel 46	Frequency Range	1 GHz ~ 40 GHz
Input Power	120 Vac, 60 Hz	Detector Function	Peak (PK) Average (AV)
Environmental Conditions	25 deg. C, 65 % RH	Tested By	Toby Tian

Antenna Polarity & Test Distance: Horizontal at 3 m										
Frequency (MHz)	Emission Level (dBuV/m)	Read Level (dBuV)	Limit (dBuV/m)	Margin (dB)	Antenna Factor (dB/m)	Cable Loss (dB)	Preamp Factor (dB)	Antenna Height (cm)	Table Angle (Degree)	Remark
5010	38.74	38.63	54	-15.26	31.21	6.13	37.23	101	76	Average
5010	60.17	60.06	74	-13.83	31.21	6.13	37.23	101	76	Peak
5230	84.49	84.18			31.39	6.24	37.32	101	76	Average
5230	94.49	94.18			31.39	6.24	37.32	101	76	Peak
5374	38.65	38.03	54	-15.35	31.49	6.31	37.18	101	76	Average
5374	60.84	60.22	74	-13.16	31.49	6.31	37.18	101	76	Peak

Antenna Polarity & Test Distance: Vertical at 3 m										
Frequency (MHz)	Emission Level (dBuV/m)	Read Level (dBuV)	Limit (dBuV/m)	Margin (dB)	Antenna Factor (dB/m)	Cable Loss (dB)	Preamp Factor (dB)	Antenna Height (cm)	Table Angle (Degree)	Remark
5016	38.62	38.49	54	-15.38	31.21	6.15	37.23	100	332	Average
5016	60.74	60.61	74	-13.26	31.21	6.15	37.23	100	332	Peak
5230	82.22	81.91			31.39	6.24	37.32	100	332	Average
5230	92.47	92.16			31.39	6.24	37.32	100	332	Peak
5418	38.61	37.94	54	-15.39	31.53	6.32	37.18	100	332	Average
5418	60.27	59.6	74	-13.73	31.53	6.32	37.18	100	332	Peak

Remarks:

- Emission Level = Read Level + Antenna Factor + Cable Loss - Preamp Factor  
Margin value = Emission level – Limit value
- 5230 MHz: Fundamental Frequency

EUT Test Condition		Measurement Detail	
Channel	Channel 54	Frequency Range	1 GHz ~ 40 GHz
Input Power	120 Vac, 60 Hz	Detector Function	Peak (PK) Average (AV)
Environmental Conditions	25 deg. C, 65 % RH	Tested By	Toby Tian

Antenna Polarity & Test Distance: Horizontal at 3 m										
Frequency (MHz)	Emission Level (dBuV/m)	Read Level (dBuV)	Limit (dBuV/m)	Margin (dB)	Antenna Factor (dB/m)	Cable Loss (dB)	Preamp Factor (dB)	Antenna Height (cm)	Table Angle (Degree)	Remark
5122	38.61	38.43	54	-15.39	31.29	6.19	37.3	186	77	Average
5122	60.78	60.6	74	-13.22	31.29	6.19	37.3	186	77	Peak
5270	85.61	85.22			31.41	6.25	37.27	186	77	Average
5270	95.71	95.32			31.41	6.25	37.27	186	77	Peak
5432	38.81	38.07	54	-15.19	31.55	6.32	37.13	186	77	Average
5432	60.29	59.55	74	-13.71	31.55	6.32	37.13	186	77	Peak
Antenna Polarity & Test Distance: Vertical at 3 m										
Frequency (MHz)	Emission Level (dBuV/m)	Read Level (dBuV)	Limit (dBuV/m)	Margin (dB)	Antenna Factor (dB/m)	Cable Loss (dB)	Preamp Factor (dB)	Antenna Height (cm)	Table Angle (Degree)	Remark
5050	38.4	38.26	54	-15.6	31.24	6.15	37.25	177	326	Average
5050	59.76	59.62	74	-14.24	31.24	6.15	37.25	177	326	Peak
5270	84.27	83.88			31.41	6.25	37.27	177	326	Average
5270	94.33	93.94			31.41	6.25	37.27	177	326	Peak
5412	38.74	38.07	54	-15.26	31.53	6.32	37.18	177	326	Average
5412	60.45	59.78	74	-13.55	31.53	6.32	37.18	177	326	Peak

Remarks:

- Emission Level = Read Level + Antenna Factor + Cable Loss - Preamp Factor  
Margin value = Emission level – Limit value
- 5270 MHz: Fundamental Frequency

EUT Test Condition		Measurement Detail	
Channel	Channel 62	Frequency Range	1 GHz ~ 40 GHz
Input Power	120 Vac, 60 Hz	Detector Function	Peak (PK) Average (AV)
Environmental Conditions	25 deg. C, 65 % RH	Tested By	Toby Tian

Antenna Polarity & Test Distance: Horizontal at 3 m										
Frequency (MHz)	Emission Level (dBuV/m)	Read Level (dBuV)	Limit (dBuV/m)	Margin (dB)	Antenna Factor (dB/m)	Cable Loss (dB)	Preamp Factor (dB)	Antenna Height (cm)	Table Angle (Degree)	Remark
5026	38.41	38.27	54	-15.59	31.23	6.15	37.24	189	64	Average
5026	60.02	59.88	74	-13.98	31.23	6.15	37.24	189	64	Peak
5310	85.44	84.91			31.45	6.27	37.19	189	64	Average
5310	95.8	95.27			31.45	6.27	37.19	189	64	Peak
5390	41.17	40.53	54	-12.83	31.51	6.31	37.18	189	64	Average
5390	60.98	60.34	74	-13.02	31.51	6.31	37.18	189	64	Peak
Antenna Polarity & Test Distance: Vertical at 3 m										
Frequency (MHz)	Emission Level (dBuV/m)	Read Level (dBuV)	Limit (dBuV/m)	Margin (dB)	Antenna Factor (dB/m)	Cable Loss (dB)	Preamp Factor (dB)	Antenna Height (cm)	Table Angle (Degree)	Remark
5008	38.3	38.19	54	-15.7	31.21	6.13	37.23	177	324	Average
5008	60.03	59.92	74	-13.97	31.21	6.13	37.23	177	324	Peak
5310	84.17	83.64			31.45	6.27	37.19	177	324	Average
5310	94.32	93.79			31.45	6.27	37.19	177	324	Peak
5350	39.53	38.94	54	-14.47	31.48	6.29	37.18	177	324	Average
5350	60.62	60.03	74	-13.38	31.48	6.29	37.18	177	324	Peak

Remarks:

- Emission Level = Read Level + Antenna Factor + Cable Loss - Preamp Factor  
Margin value = Emission level – Limit value
- 5310 MHz: Fundamental Frequency

EUT Test Condition		Measurement Detail	
Channel	Channel 102	Frequency Range	1 GHz ~ 40 GHz
Input Power	120 Vac, 60 Hz	Detector Function	Peak (PK) Average (AV)
Environmental Conditions	25 deg. C, 65 % RH	Tested By	Toby Tian

Antenna Polarity & Test Distance: Horizontal at 3 m										
Frequency (MHz)	Emission Level (dBuV/m)	Read Level (dBuV)	Limit (dBuV/m)	Margin (dB)	Antenna Factor (dB/m)	Cable Loss (dB)	Preamp Factor (dB)	Antenna Height (cm)	Table Angle (Degree)	Remark
5450	40.18	39.36	54	-13.82	31.56	6.34	37.08	189	72	Average
5450	60.36	59.54	74	-13.64	31.56	6.34	37.08	189	72	Peak
5470	61.67	60.84	68.2	-6.53	31.57	6.34	37.08	189	72	Peak
5510	85.53	84.63			31.6	6.36	37.06	189	72	Average
5510	95.99	95.09			31.6	6.36	37.06	189	72	Peak
5725	59.79	58.51	68.2	-8.41	31.96	6.75	37.43	189	72	Peak
Antenna Polarity & Test Distance: Vertical at 3 m										
Frequency (MHz)	Emission Level (dBuV/m)	Read Level (dBuV)	Limit (dBuV/m)	Margin (dB)	Antenna Factor (dB/m)	Cable Loss (dB)	Preamp Factor (dB)	Antenna Height (cm)	Table Angle (Degree)	Remark
5458	39.37	38.55	54	-14.63	31.56	6.34	37.08	192	335	Average
5458	60.06	59.24	74	-13.94	31.56	6.34	37.08	192	335	Peak
5470	58.73	57.9	68.2	-9.47	31.57	6.34	37.08	192	335	Peak
5510	82.97	82.07			31.6	6.36	37.06	192	335	Average
5510	93.14	92.24			31.6	6.36	37.06	192	335	Peak
5725	60.9	59.62	68.2	-7.3	31.96	6.75	37.43	192	335	Peak

Remarks:

- Emission Level = Read Level + Antenna Factor + Cable Loss - Preamp Factor  
Margin value = Emission level – Limit value
- 5510 MHz: Fundamental Frequency
- 5470 MHz & 5725 MHz: Out of Restricted Band

EUT Test Condition		Measurement Detail	
Channel	Channel 110	Frequency Range	1 GHz ~ 40 GHz
Input Power	120 Vac, 60 Hz	Detector Function	Peak (PK) Average (AV)
Environmental Conditions	25 deg. C, 65 % RH	Tested By	Toby Tian

Antenna Polarity & Test Distance: Horizontal at 3 m										
Frequency (MHz)	Emission Level (dBuV/m)	Read Level (dBuV)	Limit (dBuV/m)	Margin (dB)	Antenna Factor (dB/m)	Cable Loss (dB)	Preamp Factor (dB)	Antenna Height (cm)	Table Angle (Degree)	Remark
5414	39.13	38.46	54	-14.87	31.53	6.32	37.18	208	96	Average
5414	59.64	58.97	74	-14.36	31.53	6.32	37.18	208	96	Peak
5470	57.32	56.49	68.2	-10.88	31.57	6.34	37.08	208	96	Peak
5550	85.16	84.15			31.68	6.42	37.09	208	96	Average
5550	95.85	94.84			31.68	6.42	37.09	208	96	Peak
5725	60.28	59	68.2	-7.92	31.96	6.75	37.43	208	96	Peak
Antenna Polarity & Test Distance: Vertical at 3 m										
Frequency (MHz)	Emission Level (dBuV/m)	Read Level (dBuV)	Limit (dBuV/m)	Margin (dB)	Antenna Factor (dB/m)	Cable Loss (dB)	Preamp Factor (dB)	Antenna Height (cm)	Table Angle (Degree)	Remark
5440	38.94	38.18	54	-15.06	31.55	6.34	37.13	191	345	Average
5440	60.14	59.38	74	-13.86	31.55	6.34	37.13	191	345	Peak
5470	58.65	57.82	68.2	-9.55	31.57	6.34	37.08	191	345	Peak
5550	82.64	81.63			31.68	6.42	37.09	191	345	Average
5550	93.15	92.14			31.68	6.42	37.09	191	345	Peak
5725	59.89	58.61	68.2	-8.31	31.96	6.75	37.43	191	345	Peak

Remarks:

- Emission Level = Read Level + Antenna Factor + Cable Loss - Preamp Factor  
Margin value = Emission level – Limit value
- 5550 MHz: Fundamental Frequency
- 5470 MHz & 5725 MHz: Out of Restricted Band

EUT Test Condition		Measurement Detail	
Channel	Channel 134	Frequency Range	1 GHz ~ 40 GHz
Input Power	120 Vac, 60 Hz	Detector Function	Peak (PK) Average (AV)
Environmental Conditions	25 deg. C, 65 % RH	Tested By	Toby Tian

Antenna Polarity & Test Distance: Horizontal at 3 m										
Frequency (MHz)	Emission Level (dBuV/m)	Read Level (dBuV)	Limit (dBuV/m)	Margin (dB)	Antenna Factor (dB/m)	Cable Loss (dB)	Preamp Factor (dB)	Antenna Height (cm)	Table Angle (Degree)	Remark
5446	38.82	38.05	54	-15.18	31.56	6.34	37.13	205	108	Average
5446	60.17	59.4	74	-13.83	31.56	6.34	37.13	205	108	Peak
5470	57.6	56.77	68.2	-10.6	31.57	6.34	37.08	205	108	Peak
5670	85.62	84.46			31.88	6.62	37.34	205	108	Average
5670	95.72	94.56			31.88	6.62	37.34	205	108	Peak
5725	61.54	60.26	68.2	-6.66	31.96	6.75	37.43	205	108	Peak
Antenna Polarity & Test Distance: Vertical at 3 m										
Frequency (MHz)	Emission Level (dBuV/m)	Read Level (dBuV)	Limit (dBuV/m)	Margin (dB)	Antenna Factor (dB/m)	Cable Loss (dB)	Preamp Factor (dB)	Antenna Height (cm)	Table Angle (Degree)	Remark
5420	38.84	38.17	54	-15.16	31.53	6.32	37.18	184	346	Average
5420	60.22	59.55	74	-13.78	31.53	6.32	37.18	184	346	Peak
5470	58.07	57.24	68.2	-10.13	31.57	6.34	37.08	184	346	Peak
5670	82.93	81.77			31.88	6.62	37.34	184	346	Average
5670	92.97	91.81			31.88	6.62	37.34	184	346	Peak
5725	59.48	58.2	68.2	-8.72	31.96	6.75	37.43	184	346	Peak

Remarks:

- Emission Level = Read Level + Antenna Factor + Cable Loss - Preamp Factor  
Margin value = Emission level – Limit value
- 5670 MHz: Fundamental Frequency
- 5470 MHz & 5725 MHz: Out of Restricted Band

EUT Test Condition		Measurement Detail	
Channel	Channel 151	Frequency Range	1 GHz ~ 40 GHz
Input Power	120 Vac, 60 Hz	Detector Function	Peak (PK) Average (AV)
Environmental Conditions	25 deg. C, 65 % RH	Tested By	Gavin Wu

Antenna Polarity & Test Distance: Horizontal at 3 m										
Frequency (MHz)	Emission Level (dBuV/m)	Read Level (dBuV)	Limit (dBuV/m)	Margin (dB)	Antenna Factor (dB/m)	Cable Loss (dB)	Preamp Factor (dB)	Antenna Height (cm)	Table Angle (Degree)	Remark
*5714	60.22	59.03	68.2	-7.98	31.93	6.69	37.43	129	88	Peak
*5725	61.6	60.32	78.2	-16.6	31.96	6.75	37.43	129	88	Peak
5755	84.38	83.09			32.01	6.75	37.47	129	88	Average
5755	94.21	92.92			32.01	6.75	37.47	129	88	Peak
*5850	59.88	58.36	78.2	-18.32	32.15	6.88	37.51	129	88	Peak
*5861	59.71	58.08	68.2	-8.49	32.18	6.95	37.5	129	88	Peak
Antenna Polarity & Test Distance: Vertical at 3 m										
Frequency (MHz)	Emission Level (dBuV/m)	Read Level (dBuV)	Limit (dBuV/m)	Margin (dB)	Antenna Factor (dB/m)	Cable Loss (dB)	Preamp Factor (dB)	Antenna Height (cm)	Table Angle (Degree)	Remark
*5714	58.49	57.3	68.2	-9.71	31.93	6.69	37.43	225	22	Peak
*5725	60.75	59.47	78.2	-17.45	31.96	6.75	37.43	225	22	Peak
5755	81.44	80.15			32.01	6.75	37.47	225	22	Average
5755	90.17	88.88			32.01	6.75	37.47	225	22	Peak
*5850	59.6	58.08	78.2	-18.6	32.15	6.88	37.51	225	22	Peak
*5861	58.79	57.16	68.2	-9.41	32.18	6.95	37.5	225	22	Peak

Remarks:

- Emission Level = Read Level + Antenna Factor + Cable Loss - Preamp Factor  
Margin value = Emission level – Limit value
- 5755 MHz: Fundamental Frequency
- \*: Out of Restricted Band



EUT Test Condition		Measurement Detail	
Channel	Channel 159	Frequency Range	1 GHz ~ 40 GHz
Input Power	120 Vac, 60 Hz	Detector Function	Peak (PK) Average (AV)
Environmental Conditions	25 deg. C, 65 % RH	Tested By	Gavin Wu

Antenna Polarity & Test Distance: Horizontal at 3 m										
Frequency (MHz)	Emission Level (dBuV/m)	Read Level (dBuV)	Limit (dBuV/m)	Margin (dB)	Antenna Factor (dB/m)	Cable Loss (dB)	Preamp Factor (dB)	Antenna Height (cm)	Table Angle (Degree)	Remark
*5714	59.37	58.18	68.2	-8.83	31.93	6.69	37.43	106	83	Peak
*5725	60.74	59.46	78.2	-17.46	31.96	6.75	37.43	106	83	Peak
5795	84.58	83.23			32.07	6.82	37.54	106	83	Average
5795	94.2	92.85			32.07	6.82	37.54	106	83	Peak
*5850	60.44	58.92	78.2	-17.76	32.15	6.88	37.51	106	83	Peak
*5861	58.99	57.36	68.2	-9.21	32.18	6.95	37.5	106	83	Peak
Antenna Polarity & Test Distance: Vertical at 3 m										
Frequency (MHz)	Emission Level (dBuV/m)	Read Level (dBuV)	Limit (dBuV/m)	Margin (dB)	Antenna Factor (dB/m)	Cable Loss (dB)	Preamp Factor (dB)	Antenna Height (cm)	Table Angle (Degree)	Remark
*5714	59.58	58.39	68.2	-8.62	31.93	6.69	37.43	222	21	Peak
*5725	59.46	58.18	78.2	-18.74	31.96	6.75	37.43	222	21	Peak
5795	80.84	79.49			32.07	6.82	37.54	222	21	Average
5795	89.89	88.54			32.07	6.82	37.54	222	21	Peak
*5850	59.41	57.89	78.2	-18.79	32.15	6.88	37.51	222	21	Peak
*5861	59.84	58.21	68.2	-8.36	32.18	6.95	37.5	222	21	Peak

Remarks:

- Emission Level = Read Level + Antenna Factor + Cable Loss - Preamp Factor  
Margin value = Emission level – Limit value
- 5795 MHz: Fundamental Frequency
- \*: Out of Restricted Band

802.11ac (VHT80)

EUT Test Condition		Measurement Detail	
Channel	Channel 42	Frequency Range	1 GHz ~ 40 GHz
Input Power	120 Vac, 60 Hz	Detector Function	Peak (PK) Average (AV)
Environmental Conditions	25 deg. C, 65 % RH	Tested By	Toby Tian

Antenna Polarity & Test Distance: Horizontal at 3 m										
Frequency (MHz)	Emission Level (dBuV/m)	Read Level (dBuV)	Limit (dBuV/m)	Margin (dB)	Antenna Factor (dB/m)	Cable Loss (dB)	Preamp Factor (dB)	Antenna Height (cm)	Table Angle (Degree)	Remark
5054	40.06	39.9	54	-13.94	31.24	6.17	37.25	101	86	Average
5054	61.25	61.09	74	-12.75	31.24	6.17	37.25	101	86	Peak
5210	79.98	79.73			31.37	6.24	37.36	101	86	Average
5210	90.19	89.94			31.37	6.24	37.36	101	86	Peak
5426	38.97	38.25	54	-15.03	31.53	6.32	37.13	101	86	Average
5426	59.92	59.2	74	-14.08	31.53	6.32	37.13	101	86	Peak

Antenna Polarity & Test Distance: Vertical at 3 m										
Frequency (MHz)	Emission Level (dBuV/m)	Read Level (dBuV)	Limit (dBuV/m)	Margin (dB)	Antenna Factor (dB/m)	Cable Loss (dB)	Preamp Factor (dB)	Antenna Height (cm)	Table Angle (Degree)	Remark
5138	39.55	39.34	54	-14.45	31.31	6.2	37.3	100	326	Average
5138	60.03	59.82	74	-13.97	31.31	6.2	37.3	100	326	Peak
5210	77.77	77.52			31.37	6.24	37.36	100	326	Average
5210	87.78	87.53			31.37	6.24	37.36	100	326	Peak
5448	38.91	38.14	54	-15.09	31.56	6.34	37.13	100	326	Average
5448	60.29	59.52	74	-13.71	31.56	6.34	37.13	100	326	Peak

Remarks:

- Emission Level = Read Level + Antenna Factor + Cable Loss - Preamp Factor  
Margin value = Emission level – Limit value
- 5210 MHz: Fundamental Frequency

EUT Test Condition		Measurement Detail	
Channel	Channel 58	Frequency Range	1 GHz ~ 40 GHz
Input Power	120 Vac, 60 Hz	Detector Function	Peak (PK) Average (AV)
Environmental Conditions	25 deg. C, 65 % RH	Tested By	Toby Tian

Antenna Polarity & Test Distance: Horizontal at 3 m										
Frequency (MHz)	Emission Level (dBuV/m)	Read Level (dBuV)	Limit (dBuV/m)	Margin (dB)	Antenna Factor (dB/m)	Cable Loss (dB)	Preamp Factor (dB)	Antenna Height (cm)	Table Angle (Degree)	Remark
5144	38.76	38.56	54	-15.24	31.32	6.2	37.32	187	89	5144
5144	59.86	59.66	74	-14.14	31.32	6.2	37.32	187	89	5144
5290	80.44	79.97			31.43	6.27	37.23	187	89	5290
5290	91.04	90.57			31.43	6.27	37.23	187	89	5290
5374	45.43	44.81	54	-8.57	31.49	6.31	37.18	187	89	5374
5374	60.44	59.82	74	-13.56	31.49	6.31	37.18	187	89	5374

Antenna Polarity & Test Distance: Vertical at 3 m										
Frequency (MHz)	Emission Level (dBuV/m)	Read Level (dBuV)	Limit (dBuV/m)	Margin (dB)	Antenna Factor (dB/m)	Cable Loss (dB)	Preamp Factor (dB)	Antenna Height (cm)	Table Angle (Degree)	Remark
5114	38.67	38.47	54	-15.33	31.29	6.19	37.28	177	306	Average
5114	60.43	60.23	74	-13.57	31.29	6.19	37.28	177	306	Peak
5290	78.68	78.21			31.43	6.27	37.23	177	306	Average
5290	89.15	88.68			31.43	6.27	37.23	177	306	Peak
5362	41.87	41.25	54	-12.13	31.49	6.31	37.18	177	306	Average
5362	60.2	59.58	74	-13.8	31.49	6.31	37.18	177	306	Peak

Remarks:

- Emission Level = Read Level + Antenna Factor + Cable Loss - Preamp Factor  
Margin value = Emission level – Limit value
- 5290 MHz: Fundamental Frequency

EUT Test Condition		Measurement Detail	
Channel	Channel 106	Frequency Range	1 GHz ~ 40 GHz
Input Power	120 Vac, 60 Hz	Detector Function	Peak (PK) Average (AV)
Environmental Conditions	25 deg. C, 65 % RH	Tested By	Toby Tian

Antenna Polarity & Test Distance: Horizontal at 3 m										
Frequency (MHz)	Emission Level (dBuV/m)	Read Level (dBuV)	Limit (dBuV/m)	Margin (dB)	Antenna Factor (dB/m)	Cable Loss (dB)	Preamp Factor (dB)	Antenna Height (cm)	Table Angle (Degree)	Remark
5360	40.1	39.49	54	-13.9	31.48	6.31	37.18	188	85	Average
5360	60.38	59.77	74	-13.62	31.48	6.31	37.18	188	85	Peak
5470	59.01	58.18	68.2	-9.19	31.57	6.34	37.08	188	85	Peak
5530	80.16	79.2			31.63	6.42	37.09	188	85	Average
5530	90.83	89.87			31.63	6.42	37.09	188	85	Peak
5725	59.72	58.44	68.2	-8.48	31.96	6.75	37.43	188	85	Peak
Antenna Polarity & Test Distance: Vertical at 3 m										
Frequency (MHz)	Emission Level (dBuV/m)	Read Level (dBuV)	Limit (dBuV/m)	Margin (dB)	Antenna Factor (dB/m)	Cable Loss (dB)	Preamp Factor (dB)	Antenna Height (cm)	Table Angle (Degree)	Remark
5442	39.95	39.19	54	-14.05	31.55	6.34	37.13	184	344	Average
5442	59.46	58.7	74	-14.54	31.55	6.34	37.13	184	344	Peak
5470	58.11	57.28	68.2	-10.09	31.57	6.34	37.08	184	344	Peak
5530	77.96	77			31.63	6.42	37.09	184	344	Average
5530	88.48	87.52			31.63	6.42	37.09	184	344	Peak
5725	57.8	56.52	68.2	-10.4	31.96	6.75	37.43	184	344	Peak

Remarks:

- Emission Level = Read Level + Antenna Factor + Cable Loss - Preamp Factor  
Margin value = Emission level – Limit value
- 5530 MHz: Fundamental Frequency
- 5470 MHz & 5725 MHz: Out of Restricted Band

EUT Test Condition		Measurement Detail	
Channel	Channel 122	Frequency Range	1 GHz ~ 40 GHz
Input Power	120 Vac, 60 Hz	Detector Function	Peak (PK) Average (AV)
Environmental Conditions	25 deg. C, 65 % RH	Tested By	Gavin Wu

Antenna Polarity & Test Distance: Horizontal at 3 m										
Frequency (MHz)	Emission Level (dBuV/m)	Read Level (dBuV)	Limit (dBuV/m)	Margin (dB)	Antenna Factor (dB/m)	Cable Loss (dB)	Preamp Factor (dB)	Antenna Height (cm)	Table Angle (Degree)	Remark
5374	37.62	37	54	-16.38	31.49	6.31	37.18	210	192	Average
5374	58.92	58.3	74	-15.08	31.49	6.31	37.18	210	192	Peak
5470	57.29	56.46	68.2	-10.91	31.57	6.34	37.08	210	192	Peak
5610	80.95	79.84			31.77	6.56	37.22	210	192	Average
5610	91.2	90.09			31.77	6.56	37.22	210	192	Peak
5725	58.19	56.91	68.2	-10.01	31.96	6.75	37.43	210	192	Peak
Antenna Polarity & Test Distance: Vertical at 3 m										
Frequency (MHz)	Emission Level (dBuV/m)	Read Level (dBuV)	Limit (dBuV/m)	Margin (dB)	Antenna Factor (dB/m)	Cable Loss (dB)	Preamp Factor (dB)	Antenna Height (cm)	Table Angle (Degree)	Remark
5438	37.28	36.52	54	-16.72	31.55	6.34	37.13	200	163	Average
5438	59.38	58.62	74	-14.62	31.55	6.34	37.13	200	163	Peak
5470	58.91	58.08	68.2	-9.29	31.57	6.34	37.08	200	163	Peak
5610	79.16	78.05			31.77	6.56	37.22	200	163	Average
5610	89.62	88.51			31.77	6.56	37.22	200	163	Peak
5725	59.99	58.71	68.2	-8.21	31.96	6.75	37.43	200	163	Peak

Remarks:

- Emission Level = Read Level + Antenna Factor + Cable Loss - Preamp Factor  
Margin value = Emission level – Limit value
- 5610 MHz: Fundamental Frequency
- 5470 MHz & 5725 MHz: Out of Restricted Band

EUT Test Condition		Measurement Detail	
Channel	Channel 155	Frequency Range	1 GHz ~ 40 GHz
Input Power	120 Vac, 60 Hz	Detector Function	Peak (PK) Average (AV)
Environmental Conditions	25 deg. C, 65 % RH	Tested By	Gavin Wu

Antenna Polarity & Test Distance: Horizontal at 3 m										
Frequency (MHz)	Emission Level (dBuV/m)	Read Level (dBuV)	Limit (dBuV/m)	Margin (dB)	Antenna Factor (dB/m)	Cable Loss (dB)	Preamp Factor (dB)	Antenna Height (cm)	Table Angle (Degree)	Remark
*5714	58.17	56.98	68.2	-10.03	31.93	6.69	37.43	116	82	Peak
*5725	60.23	58.95	78.2	-17.97	31.96	6.75	37.43	116	82	Peak
5775	78.01	76.65			32.04	6.82	37.5	116	82	Average
5775	89.16	87.8			32.04	6.82	37.5	116	82	Peak
*5850	59.16	57.64	78.2	-19.04	32.15	6.88	37.51	116	82	Peak
*5861	59.09	57.46	68.2	-9.11	32.18	6.95	37.5	116	82	Peak
Antenna Polarity & Test Distance: Vertical at 3 m										
Frequency (MHz)	Emission Level (dBuV/m)	Read Level (dBuV)	Limit (dBuV/m)	Margin (dB)	Antenna Factor (dB/m)	Cable Loss (dB)	Preamp Factor (dB)	Antenna Height (cm)	Table Angle (Degree)	Remark
*5714	60.39	59.2	68.2	-7.81	31.93	6.69	37.43	216	22	Peak
*5725	59.53	58.25	78.2	-18.67	31.96	6.75	37.43	216	22	Peak
5775	74.73	73.37			32.04	6.82	37.5	216	22	Average
5775	85.77	84.41			32.04	6.82	37.5	216	22	Peak
*5850	60.08	58.56	78.2	-18.12	32.15	6.88	37.51	216	22	Peak
*5861	58.63	57	68.2	-9.57	32.18	6.95	37.5	216	22	Peak

Remarks:

- Emission Level = Read Level + Antenna Factor + Cable Loss - Preamp Factor  
Margin value = Emission level – Limit value
- 5775 MHz: Fundamental Frequency
- \*: Out of Restricted Band

**Mode D**

**802.11n (HT20)**

EUT Test Condition		Measurement Detail	
Channel	Channel 36	Frequency Range	1 GHz ~ 40 GHz
Input Power	120 Vac, 60 Hz	Detector Function	Peak (PK) Average (AV)
Environmental Conditions	25 deg. C, 65 % RH	Tested By	Toby Tian

Antenna Polarity & Test Distance: Horizontal at 3 m										
Frequency (MHz)	Emission Level (dBuV/m)	Read Level (dBuV)	Limit (dBuV/m)	Margin (dB)	Antenna Factor (dB/m)	Cable Loss (dB)	Preamp Factor (dB)	Antenna Height (cm)	Table Angle (Degree)	Remark
5146	41.95	41.75	54	-12.05	31.32	6.2	37.32	111	66	Average
5146	60.55	60.35	74	-13.45	31.32	6.2	37.32	111	66	Peak
5180	91.23	91			31.35	6.22	37.34	111	66	Average
5180	103.91	103.68			31.35	6.22	37.34	111	66	Peak
5422	38.25	37.58	54	-15.75	31.53	6.32	37.18	111	66	Average
5422	60.29	59.62	74	-13.71	31.53	6.32	37.18	111	66	Peak

Antenna Polarity & Test Distance: Vertical at 3 m										
Frequency (MHz)	Emission Level (dBuV/m)	Read Level (dBuV)	Limit (dBuV/m)	Margin (dB)	Antenna Factor (dB/m)	Cable Loss (dB)	Preamp Factor (dB)	Antenna Height (cm)	Table Angle (Degree)	Remark
5022	40.38	40.24	54	-13.62	31.23	6.15	37.24	100	340	Average
5022	59.53	59.39	74	-14.47	31.23	6.15	37.24	100	340	Peak
5180	87.51	87.28			31.35	6.22	37.34	100	340	Average
5180	101.22	100.99			31.35	6.22	37.34	100	340	Peak
5422	38.17	37.5	54	-15.83	31.53	6.32	37.18	100	340	Average
5422	59.96	59.29	74	-14.04	31.53	6.32	37.18	100	340	Peak

Remarks:

- Emission Level = Read Level + Antenna Factor + Cable Loss - Preamp Factor  
Margin value = Emission level – Limit value
- 5180 MHz: Fundamental Frequency

EUT Test Condition		Measurement Detail	
Channel	Channel 44	Frequency Range	1 GHz ~ 40 GHz
Input Power	120 Vac, 60 Hz	Detector Function	Peak (PK) Average (AV)
Environmental Conditions	25 deg. C, 65 % RH	Tested By	Toby Tian

Antenna Polarity & Test Distance: Horizontal at 3 m										
Frequency (MHz)	Emission Level (dBuV/m)	Read Level (dBuV)	Limit (dBuV/m)	Margin (dB)	Antenna Factor (dB/m)	Cable Loss (dB)	Preamp Factor (dB)	Antenna Height (cm)	Table Angle (Degree)	Remark
5146	38.33	38.13	54	-15.67	31.32	6.2	37.32	101	73	Average
5146	60.17	59.97	74	-13.83	31.32	6.2	37.32	101	73	Peak
5220	90.7	90.45			31.37	6.24	37.36	101	73	Average
5220	103.84	103.59			31.37	6.24	37.36	101	73	Peak
5368	38.22	37.6	54	-15.78	31.49	6.31	37.18	101	73	Average
5368	60.74	60.12	74	-13.26	31.49	6.31	37.18	101	73	Peak

Antenna Polarity & Test Distance: Vertical at 3 m										
Frequency (MHz)	Emission Level (dBuV/m)	Read Level (dBuV)	Limit (dBuV/m)	Margin (dB)	Antenna Factor (dB/m)	Cable Loss (dB)	Preamp Factor (dB)	Antenna Height (cm)	Table Angle (Degree)	Remark
5104	38.12	37.93	54	-15.88	31.28	6.19	37.28	105	339	Average
5104	60.42	60.23	74	-13.58	31.28	6.19	37.28	105	339	Peak
5220	87.18	86.93			31.37	6.24	37.36	105	339	Average
5220	101.16	100.91			31.37	6.24	37.36	105	339	Peak
5356	38.08	37.49	54	-15.92	31.48	6.29	37.18	105	339	Average
5356	59.95	59.36	74	-14.05	31.48	6.29	37.18	105	339	Peak

Remarks:

- Emission Level = Read Level + Antenna Factor + Cable Loss - Preamp Factor  
Margin value = Emission level – Limit value
- 5220 MHz: Fundamental Frequency



EUT Test Condition		Measurement Detail	
Channel	Channel 48	Frequency Range	1 GHz ~ 40 GHz
Input Power	120 Vac, 60 Hz	Detector Function	Peak (PK) Average (AV)
Environmental Conditions	25 deg. C, 65 % RH	Tested By	Toby Tian

**Antenna Polarity & Test Distance: Horizontal at 3 m**

Frequency (MHz)	Emission Level (dBuV/m)	Read Level (dBuV)	Limit (dBuV/m)	Margin (dB)	Antenna Factor (dB/m)	Cable Loss (dB)	Preamp Factor (dB)	Antenna Height (cm)	Table Angle (Degree)	Remark
5130	38.2	37.99	54	-15.8	31.31	6.2	37.3	188	80	Average
5130	59.94	59.73	74	-14.06	31.31	6.2	37.3	188	80	Peak
5240	90.97	90.65			31.39	6.25	37.32	188	80	Average
5240	103.87	103.55			31.39	6.25	37.32	188	80	Peak
5452	38.45	37.63	54	-15.55	31.56	6.34	37.08	188	80	Average
5452	61	60.18	74	-13	31.56	6.34	37.08	188	80	Peak

**Antenna Polarity & Test Distance: Vertical at 3 m**

Frequency (MHz)	Emission Level (dBuV/m)	Read Level (dBuV)	Limit (dBuV/m)	Margin (dB)	Antenna Factor (dB/m)	Cable Loss (dB)	Preamp Factor (dB)	Antenna Height (cm)	Table Angle (Degree)	Remark
5036	38.01	37.87	54	-15.99	31.23	6.15	37.24	101	330	Average
5036	60.73	60.59	74	-13.27	31.23	6.15	37.24	101	330	Peak
5240	87.21	86.89			31.39	6.25	37.32	101	330	Average
5240	101.45	101.13			31.39	6.25	37.32	101	330	Peak
5364	38.3	37.68	54	-15.7	31.49	6.31	37.18	101	330	Average
5364	59.87	59.25	74	-14.13	31.49	6.31	37.18	101	330	Peak

Remarks:

- Emission Level = Read Level + Antenna Factor + Cable Loss - Preamp Factor  
Margin value = Emission level – Limit value
- 5240 MHz: Fundamental Frequency

EUT Test Condition		Measurement Detail	
Channel	Channel 52	Frequency Range	1 GHz ~ 40 GHz
Input Power	120 Vac, 60 Hz	Detector Function	Peak (PK) Average (AV)
Environmental Conditions	25 deg. C, 65 % RH	Tested By	Toby Tian

Antenna Polarity & Test Distance: Horizontal at 3 m										
Frequency (MHz)	Emission Level (dBuV/m)	Read Level (dBuV)	Limit (dBuV/m)	Margin (dB)	Antenna Factor (dB/m)	Cable Loss (dB)	Preamp Factor (dB)	Antenna Height (cm)	Table Angle (Degree)	Remark
5144	38.62	38.42	54	-15.38	31.32	6.2	37.32	178	73	Average
5144	60.48	60.28	74	-13.52	31.32	6.2	37.32	178	73	Peak
5260	93.78	93.39			31.41	6.25	37.27	178	73	Average
5260	104.32	103.93			31.41	6.25	37.27	178	73	Peak
5412	38.48	37.81	54	-15.52	31.53	6.32	37.18	178	73	Average
5412	59.67	59	74	-14.33	31.53	6.32	37.18	178	73	Peak
Antenna Polarity & Test Distance: Vertical at 3 m										
Frequency (MHz)	Emission Level (dBuV/m)	Read Level (dBuV)	Limit (dBuV/m)	Margin (dB)	Antenna Factor (dB/m)	Cable Loss (dB)	Preamp Factor (dB)	Antenna Height (cm)	Table Angle (Degree)	Remark
5034	38.12	37.98	54	-15.88	31.23	6.15	37.24	106	342	Average
5034	60.42	60.28	74	-13.58	31.23	6.15	37.24	106	342	Peak
5260	90.69	90.3			31.41	6.25	37.27	106	342	Average
5260	101.49	101.1			31.41	6.25	37.27	106	342	Peak
5382	38.27	37.63	54	-15.73	31.51	6.31	37.18	106	342	Average
5382	59.99	59.35	74	-14.01	31.51	6.31	37.18	106	342	Peak

Remarks:

- Emission Level = Read Level + Antenna Factor + Cable Loss - Preamp Factor  
Margin value = Emission level – Limit value
- 5260 MHz: Fundamental Frequency

EUT Test Condition		Measurement Detail	
Channel	Channel 60	Frequency Range	1 GHz ~ 40 GHz
Input Power	120 Vac, 60 Hz	Detector Function	Peak (PK) Average (AV)
Environmental Conditions	25 deg. C, 65 % RH	Tested By	Toby Tian

Antenna Polarity & Test Distance: Horizontal at 3 m										
Frequency (MHz)	Emission Level (dBuV/m)	Read Level (dBuV)	Limit (dBuV/m)	Margin (dB)	Antenna Factor (dB/m)	Cable Loss (dB)	Preamp Factor (dB)	Antenna Height (cm)	Table Angle (Degree)	Remark
5016	38.32	38.19	54	-15.68	31.21	6.15	37.23	202	82	Average
5016	60.1	59.97	74	-13.9	31.21	6.15	37.23	202	82	Peak
5300	94.06	93.54			31.44	6.27	37.19	202	82	Average
5300	104.4	103.88			31.44	6.27	37.19	202	82	Peak
5436	38.79	38.05	54	-15.21	31.55	6.32	37.13	202	82	Average
5436	60.43	59.69	74	-13.57	31.55	6.32	37.13	202	82	Peak
Antenna Polarity & Test Distance: Vertical at 3 m										
Frequency (MHz)	Emission Level (dBuV/m)	Read Level (dBuV)	Limit (dBuV/m)	Margin (dB)	Antenna Factor (dB/m)	Cable Loss (dB)	Preamp Factor (dB)	Antenna Height (cm)	Table Angle (Degree)	Remark
5028	38.06	37.92	54	-15.94	31.23	6.15	37.24	121	340	Average
5028	60.18	60.04	74	-13.82	31.23	6.15	37.24	121	340	Peak
5300	90.92	90.4			31.44	6.27	37.19	121	340	Average
5300	101.29	100.77			31.44	6.27	37.19	121	340	Peak
5446	38.45	37.68	54	-15.55	31.56	6.34	37.13	121	340	Average
5446	60.08	59.31	74	-13.92	31.56	6.34	37.13	121	340	Peak

Remarks:

- Emission Level = Read Level + Antenna Factor + Cable Loss - Preamp Factor  
Margin value = Emission level – Limit value
- 5300 MHz: Fundamental Frequency

EUT Test Condition		Measurement Detail	
Channel	Channel 64	Frequency Range	1 GHz ~ 40 GHz
Input Power	120 Vac, 60 Hz	Detector Function	Peak (PK) Average (AV)
Environmental Conditions	25 deg. C, 65 % RH	Tested By	Toby Tian

Antenna Polarity & Test Distance: Horizontal at 3 m										
Frequency (MHz)	Emission Level (dBuV/m)	Read Level (dBuV)	Limit (dBuV/m)	Margin (dB)	Antenna Factor (dB/m)	Cable Loss (dB)	Preamp Factor (dB)	Antenna Height (cm)	Table Angle (Degree)	Remark
5054	38.33	38.17	54	-15.67	31.24	6.17	37.25	183	81	Average
5054	59.54	59.38	74	-14.46	31.24	6.17	37.25	183	81	Peak
5320	94.18	93.63			31.45	6.29	37.19	183	81	Average
5320	104.59	104.04			31.45	6.29	37.19	183	81	Peak
5426	42.54	41.82	54	-11.46	31.53	6.32	37.13	183	81	Average
5426	60.42	59.7	74	-13.58	31.53	6.32	37.13	183	81	Peak
Antenna Polarity & Test Distance: Vertical at 3 m										
Frequency (MHz)	Emission Level (dBuV/m)	Read Level (dBuV)	Limit (dBuV/m)	Margin (dB)	Antenna Factor (dB/m)	Cable Loss (dB)	Preamp Factor (dB)	Antenna Height (cm)	Table Angle (Degree)	Remark
5142	38.19	37.97	54	-15.81	31.32	6.2	37.3	120	348	Average
5142	59.96	59.74	74	-14.04	31.32	6.2	37.3	120	348	Peak
5320	90.83	90.28			31.45	6.29	37.19	120	348	Average
5320	101.34	100.79			31.45	6.29	37.19	120	348	Peak
5454	39.35	38.53	54	-14.65	31.56	6.34	37.08	120	348	Average
5454	60.13	59.31	74	-13.87	31.56	6.34	37.08	120	348	Peak

Remarks:

- Emission Level = Read Level + Antenna Factor + Cable Loss - Preamp Factor  
Margin value = Emission level – Limit value
- 5320 MHz: Fundamental Frequency

EUT Test Condition		Measurement Detail	
Channel	Channel 100	Frequency Range	1 GHz ~ 40 GHz
Input Power	120 Vac, 60 Hz	Detector Function	Peak (PK) Average (AV)
Environmental Conditions	25 deg. C, 65 % RH	Tested By	Gavin Wu

Antenna Polarity & Test Distance: Horizontal at 3 m										
Frequency (MHz)	Emission Level (dBuV/m)	Read Level (dBuV)	Limit (dBuV/m)	Margin (dB)	Antenna Factor (dB/m)	Cable Loss (dB)	Preamp Factor (dB)	Antenna Height (cm)	Table Angle (Degree)	Remark
5368	39.28	38.66	54	-14.72	31.49	6.31	37.18	188	93	Average
5368	60.22	59.6	74	-13.78	31.49	6.31	37.18	188	93	Peak
5470	59.94	59.11	68.2	-8.26	31.57	6.34	37.08	188	93	Peak
5500	94.07	93.14			31.6	6.36	37.03	188	93	Average
5500	104.71	103.78			31.6	6.36	37.03	188	93	Peak
5725	60.15	58.87	68.2	-8.05	31.96	6.75	37.43	188	93	Peak
Antenna Polarity & Test Distance: Vertical at 3 m										
Frequency (MHz)	Emission Level (dBuV/m)	Read Level (dBuV)	Limit (dBuV/m)	Margin (dB)	Antenna Factor (dB/m)	Cable Loss (dB)	Preamp Factor (dB)	Antenna Height (cm)	Table Angle (Degree)	Remark
5364	38.4	37.78	54	-15.6	31.49	6.31	37.18	208	0	Average
5364	60.1	59.48	74	-13.9	31.49	6.31	37.18	208	0	Peak
5470	58.85	58.02	68.2	-9.35	31.57	6.34	37.08	208	0	Peak
5500	90.66	89.73			31.6	6.36	37.03	208	0	Average
5500	101.46	100.53			31.6	6.36	37.03	208	0	Peak
5725	59.92	58.64	68.2	-8.28	31.96	6.75	37.43	208	0	Peak

Remarks:

- Emission Level = Read Level + Antenna Factor + Cable Loss - Preamp Factor  
Margin value = Emission level – Limit value
- 5500 MHz: Fundamental Frequency
- 5470 MHz & 5725 MHz: Out of Restricted Band

EUT Test Condition		Measurement Detail	
Channel	Channel 116	Frequency Range	1 GHz ~ 40 GHz
Input Power	120 Vac, 60 Hz	Detector Function	Peak (PK) Average (AV)
Environmental Conditions	25 deg. C, 65 % RH	Tested By	Gavin Wu

Antenna Polarity & Test Distance: Horizontal at 3 m										
Frequency (MHz)	Emission Level (dBuV/m)	Read Level (dBuV)	Limit (dBuV/m)	Margin (dB)	Antenna Factor (dB/m)	Cable Loss (dB)	Preamp Factor (dB)	Antenna Height (cm)	Table Angle (Degree)	Remark
5390	38.48	37.84	54	-15.52	31.51	6.31	37.18	151	87	Average
5390	60.57	59.93	74	-13.43	31.51	6.31	37.18	151	87	Peak
5470	59.27	58.44	68.2	-8.93	31.57	6.34	37.08	151	87	Peak
5580	93.34	92.3			31.71	6.49	37.16	151	87	Average
5580	104.01	102.97			31.71	6.49	37.16	151	87	Peak
5725	59.47	58.19	68.2	-8.73	31.96	6.75	37.43	151	87	Peak
Antenna Polarity & Test Distance: Vertical at 3 m										
Frequency (MHz)	Emission Level (dBuV/m)	Read Level (dBuV)	Limit (dBuV/m)	Margin (dB)	Antenna Factor (dB/m)	Cable Loss (dB)	Preamp Factor (dB)	Antenna Height (cm)	Table Angle (Degree)	Remark
5444	38.5	37.74	54	-15.5	31.55	6.34	37.13	206	21	Average
5444	60.16	59.4	74	-13.84	31.55	6.34	37.13	206	21	Peak
5470	58.45	57.62	68.2	-9.75	31.57	6.34	37.08	206	21	Peak
5580	91.12	90.08			31.71	6.49	37.16	206	21	Average
5580	101.43	100.39			31.71	6.49	37.16	206	21	Peak
5725	59.89	58.61	68.2	-8.31	31.96	6.75	37.43	206	21	Peak

Remarks:

- Emission Level = Read Level + Antenna Factor + Cable Loss - Preamp Factor  
Margin value = Emission level – Limit value
- 5580 MHz: Fundamental Frequency
- 5470 MHz & 5725 MHz: Out of Restricted Band

EUT Test Condition		Measurement Detail	
Channel	Channel 140	Frequency Range	1 GHz ~ 40 GHz
Input Power	120 Vac, 60 Hz	Detector Function	Peak (PK) Average (AV)
Environmental Conditions	25 deg. C, 65 % RH	Tested By	Gavin Wu

Antenna Polarity & Test Distance: Horizontal at 3 m										
Frequency (MHz)	Emission Level (dBuV/m)	Read Level (dBuV)	Limit (dBuV/m)	Margin (dB)	Antenna Factor (dB/m)	Cable Loss (dB)	Preamp Factor (dB)	Antenna Height (cm)	Table Angle (Degree)	Remark
5426	38.63	37.91	54	-15.37	31.53	6.32	37.13	161	56	Average
5426	60.61	59.89	74	-13.39	31.53	6.32	37.13	161	56	Peak
5470	59.23	58.4	68.2	-8.97	31.57	6.34	37.08	161	56	Peak
5700	93.43	92.24			31.9	6.69	37.4	161	56	Average
5700	104.34	103.15			31.9	6.69	37.4	161	56	Peak
5725	60.63	59.35	68.2	-7.57	31.96	6.75	37.43	161	56	Peak
Antenna Polarity & Test Distance: Vertical at 3 m										
Frequency (MHz)	Emission Level (dBuV/m)	Read Level (dBuV)	Limit (dBuV/m)	Margin (dB)	Antenna Factor (dB/m)	Cable Loss (dB)	Preamp Factor (dB)	Antenna Height (cm)	Table Angle (Degree)	Remark
5456	38.84	38.02	54	-15.16	31.56	6.34	37.08	201	17	Average
5456	60.53	59.71	74	-13.47	31.56	6.34	37.08	201	17	Peak
5470	57.2	56.37	68.2	-11	31.57	6.34	37.08	201	17	Peak
5700	91.58	90.39			31.9	6.69	37.4	201	17	Average
5700	101.86	100.67			31.9	6.69	37.4	201	17	Peak
5725	59.26	57.98	68.2	-8.94	31.96	6.75	37.43	201	17	Peak

Remarks:

- Emission Level = Read Level + Antenna Factor + Cable Loss - Preamp Factor  
Margin value = Emission level – Limit value
- 5700 MHz: Fundamental Frequency
- 5470 MHz & 5725 MHz: Out of Restricted Band

EUT Test Condition		Measurement Detail	
Channel	Channel 149	Frequency Range	1 GHz ~ 40 GHz
Input Power	120 Vac, 60 Hz	Detector Function	Peak (PK) Average (AV)
Environmental Conditions	25 deg. C, 65 % RH	Tested By	Toby Tian

Antenna Polarity & Test Distance: Horizontal at 3 m										
Frequency (MHz)	Emission Level (dBuV/m)	Read Level (dBuV)	Limit (dBuV/m)	Margin (dB)	Antenna Factor (dB/m)	Cable Loss (dB)	Preamp Factor (dB)	Antenna Height (cm)	Table Angle (Degree)	Remark
*5714	60.95	59.76	68.2	-7.25	31.93	6.69	37.43	107	87	Peak
*5725	64.6	63.32	78.2	-13.6	31.96	6.75	37.43	107	87	Peak
5745	94.28	93.01			31.99	6.75	37.47	107	87	Average
5745	104.39	103.12			31.99	6.75	37.47	107	87	Peak
*5850	60.25	58.73	78.2	-17.95	32.15	6.88	37.51	107	87	Peak
*5861	59.63	58	68.2	-8.57	32.18	6.95	37.5	107	87	Peak
Antenna Polarity & Test Distance: Vertical at 3 m										
Frequency (MHz)	Emission Level (dBuV/m)	Read Level (dBuV)	Limit (dBuV/m)	Margin (dB)	Antenna Factor (dB/m)	Cable Loss (dB)	Preamp Factor (dB)	Antenna Height (cm)	Table Angle (Degree)	Remark
*5714	59.85	58.66	68.2	-8.35	31.93	6.69	37.43	180	26	Peak
*5725	60.35	59.07	78.2	-17.85	31.96	6.75	37.43	180	26	Peak
5745	91.36	90.09			31.99	6.75	37.47	180	26	Average
5745	101.71	100.44			31.99	6.75	37.47	180	26	Peak
*5850	59.44	57.92	78.2	-18.76	32.15	6.88	37.51	180	26	Peak
*5861	60.64	59.01	68.2	-7.56	32.18	6.95	37.5	180	26	Peak

Remarks:

- Emission Level = Read Level + Antenna Factor + Cable Loss - Preamp Factor  
Margin value = Emission level – Limit value
- 5745 MHz: Fundamental Frequency
- \*: Out of Restricted Band



EUT Test Condition		Measurement Detail	
Channel	Channel 157	Frequency Range	1 GHz ~ 40 GHz
Input Power	120 Vac, 60 Hz	Detector Function	Peak (PK) Average (AV)
Environmental Conditions	25 deg. C, 65 % RH	Tested By	Toby Tian

Antenna Polarity & Test Distance: Horizontal at 3 m										
Frequency (MHz)	Emission Level (dBuV/m)	Read Level (dBuV)	Limit (dBuV/m)	Margin (dB)	Antenna Factor (dB/m)	Cable Loss (dB)	Preamp Factor (dB)	Antenna Height (cm)	Table Angle (Degree)	Remark
*5714	60.76	59.57	68.2	-7.44	31.93	6.69	37.43	106	66	Peak
*5725	60.22	58.94	78.2	-17.98	31.96	6.75	37.43	106	66	Peak
5785	94.54	93.22			32.04	6.82	37.54	106	66	Average
5785	104.58	103.26			32.04	6.82	37.54	106	66	Peak
*5850	59.48	57.96	78.2	-18.72	32.15	6.88	37.51	106	66	Peak
*5861	59	57.37	68.2	-9.2	32.18	6.95	37.5	106	66	Peak
Antenna Polarity & Test Distance: Vertical at 3 m										
Frequency (MHz)	Emission Level (dBuV/m)	Read Level (dBuV)	Limit (dBuV/m)	Margin (dB)	Antenna Factor (dB/m)	Cable Loss (dB)	Preamp Factor (dB)	Antenna Height (cm)	Table Angle (Degree)	Remark
*5714	59.81	58.62	68.2	-8.39	31.93	6.69	37.43	109	11	Peak
*5725	59.17	57.89	78.2	-19.03	31.96	6.75	37.43	109	11	Peak
5785	92.05	90.73			32.04	6.82	37.54	109	11	Average
5785	102.08	100.76			32.04	6.82	37.54	109	11	Peak
*5850	61.08	59.56	78.2	-17.12	32.15	6.88	37.51	109	11	Peak
*5861	60.74	59.11	68.2	-7.46	32.18	6.95	37.5	109	11	Peak

Remarks:

- Emission Level = Read Level + Antenna Factor + Cable Loss - Preamp Factor  
Margin value = Emission level – Limit value
- 5785 MHz: Fundamental Frequency
- \*: Out of Restricted Band

EUT Test Condition		Measurement Detail	
Channel	Channel 165	Frequency Range	1 GHz ~ 40 GHz
Input Power	120 Vac, 60 Hz	Detector Function	Peak (PK) Average (AV)
Environmental Conditions	25 deg. C, 65 % RH	Tested By	Toby Tian

Antenna Polarity & Test Distance: Horizontal at 3 m										
Frequency (MHz)	Emission Level (dBuV/m)	Read Level (dBuV)	Limit (dBuV/m)	Margin (dB)	Antenna Factor (dB/m)	Cable Loss (dB)	Preamp Factor (dB)	Antenna Height (cm)	Table Angle (Degree)	Remark
*5714	59.31	58.12	68.2	-8.89	31.93	6.69	37.43	108	68	Peak
*5725	59.17	57.89	78.2	-19.03	31.96	6.75	37.43	108	68	Peak
5825	94.2	92.73			32.12	6.88	37.53	108	68	Average
5825	104.61	103.14			32.12	6.88	37.53	108	68	Peak
*5850	59.86	58.34	78.2	-18.34	32.15	6.88	37.51	108	68	Peak
*5861	60.61	58.98	68.2	-7.59	32.18	6.95	37.5	108	68	Peak
Antenna Polarity & Test Distance: Vertical at 3 m										
Frequency (MHz)	Emission Level (dBuV/m)	Read Level (dBuV)	Limit (dBuV/m)	Margin (dB)	Antenna Factor (dB/m)	Cable Loss (dB)	Preamp Factor (dB)	Antenna Height (cm)	Table Angle (Degree)	Remark
*5714	59.42	58.23	68.2	-8.78	31.93	6.69	37.43	107	12	Peak
*5725	59.5	58.22	78.2	-18.7	31.96	6.75	37.43	107	12	Peak
5825	91.56	90.09			32.12	6.88	37.53	107	12	Average
5825	101.55	100.08			32.12	6.88	37.53	107	12	Peak
*5850	59.62	58.1	78.2	-18.58	32.15	6.88	37.51	107	12	Peak
*5861	60.59	58.96	68.2	-7.61	32.18	6.95	37.5	107	12	Peak

Remarks:

- Emission Level = Read Level + Antenna Factor + Cable Loss - Preamp Factor  
Margin value = Emission level – Limit value
- 5825 MHz: Fundamental Frequency
- \*: Out of Restricted Band

### 802.11ac (VHT40)

EUT Test Condition		Measurement Detail	
Channel	Channel 38	Frequency Range	1 GHz ~ 40 GHz
Input Power	120 Vac, 60 Hz	Detector Function	Peak (PK) Average (AV)
Environmental Conditions	25 deg. C, 65 % RH	Tested By	Toby Tian

#### Antenna Polarity & Test Distance: Horizontal at 3 m

Frequency (MHz)	Emission Level (dBuV/m)	Read Level (dBuV)	Limit (dBuV/m)	Margin (dB)	Antenna Factor (dB/m)	Cable Loss (dB)	Preamp Factor (dB)	Antenna Height (cm)	Table Angle (Degree)	Remark
5150	44.36	44.16	54	-9.64	31.32	6.2	37.32	101	82	Average
5150	61.53	61.33	74	-12.47	31.32	6.2	37.32	101	82	Peak
5190	85.98	85.75			31.35	6.22	37.34	101	82	Average
5190	99.2	98.97			31.35	6.22	37.34	101	82	Peak
5444	38.98	38.22	54	-15.02	31.55	6.34	37.13	101	82	Average
5444	60.4	59.64	74	-13.6	31.55	6.34	37.13	101	82	Peak

#### Antenna Polarity & Test Distance: Vertical at 3 m

Frequency (MHz)	Emission Level (dBuV/m)	Read Level (dBuV)	Limit (dBuV/m)	Margin (dB)	Antenna Factor (dB/m)	Cable Loss (dB)	Preamp Factor (dB)	Antenna Height (cm)	Table Angle (Degree)	Remark
5022	41.98	41.84	54	-12.02	31.23	6.15	37.24	101	332	Average
5022	59.54	59.4	74	-14.46	31.23	6.15	37.24	101	332	Peak
5190	82.9	82.67			31.35	6.22	37.34	101	332	Average
5190	96.47	96.24			31.35	6.22	37.34	101	332	Peak
5374	38.67	38.05	54	-15.33	31.49	6.31	37.18	101	332	Average
5374	60.43	59.81	74	-13.57	31.49	6.31	37.18	101	332	Peak

Remarks:

- Emission Level = Read Level + Antenna Factor + Cable Loss - Preamp Factor  
Margin value = Emission level – Limit value
- 5190 MHz: Fundamental Frequency

EUT Test Condition		Measurement Detail	
Channel	Channel 46	Frequency Range	1 GHz ~ 40 GHz
Input Power	120 Vac, 60 Hz	Detector Function	Peak (PK) Average (AV)
Environmental Conditions	25 deg. C, 65 % RH	Tested By	Toby Tian

**Antenna Polarity & Test Distance: Horizontal at 3 m**

Frequency (MHz)	Emission Level (dBuV/m)	Read Level (dBuV)	Limit (dBuV/m)	Margin (dB)	Antenna Factor (dB/m)	Cable Loss (dB)	Preamp Factor (dB)	Antenna Height (cm)	Table Angle (Degree)	Remark
5042	38.45	38.31	54	-15.55	31.24	6.15	37.25	190	81	Average
5042	60.16	60.02	74	-13.84	31.24	6.15	37.25	190	81	Peak
5230	86.1	85.79			31.39	6.24	37.32	190	81	Average
5230	99.22	98.91			31.39	6.24	37.32	190	81	Peak
5434	39.01	38.27	54	-14.99	31.55	6.32	37.13	190	81	Average
5434	60.86	60.12	74	-13.14	31.55	6.32	37.13	190	81	Peak

**Antenna Polarity & Test Distance: Vertical at 3 m**

Frequency (MHz)	Emission Level (dBuV/m)	Read Level (dBuV)	Limit (dBuV/m)	Margin (dB)	Antenna Factor (dB/m)	Cable Loss (dB)	Preamp Factor (dB)	Antenna Height (cm)	Table Angle (Degree)	Remark
5146	38.52	38.32	54	-15.48	31.32	6.2	37.32	100	319	Average
5146	60.28	60.08	74	-13.72	31.32	6.2	37.32	100	319	Peak
5230	83.03	82.72			31.39	6.24	37.32	100	319	Average
5230	96.6	96.29			31.39	6.24	37.32	100	319	Peak
5424	38.83	38.16	54	-15.17	31.53	6.32	37.18	100	319	Average
5424	59.62	58.95	74	-14.38	31.53	6.32	37.18	100	319	Peak

Remarks:

- Emission Level = Read Level + Antenna Factor + Cable Loss - Preamp Factor  
Margin value = Emission level – Limit value
- 5230 MHz: Fundamental Frequency

EUT Test Condition		Measurement Detail	
Channel	Channel 54	Frequency Range	1 GHz ~ 40 GHz
Input Power	120 Vac, 60 Hz	Detector Function	Peak (PK) Average (AV)
Environmental Conditions	25 deg. C, 65 % RH	Tested By	Toby Tian

Antenna Polarity & Test Distance: Horizontal at 3 m										
Frequency (MHz)	Emission Level (dBuV/m)	Read Level (dBuV)	Limit (dBuV/m)	Margin (dB)	Antenna Factor (dB/m)	Cable Loss (dB)	Preamp Factor (dB)	Antenna Height (cm)	Table Angle (Degree)	Remark
5042	38.54	38.4	54	-15.46	31.24	6.15	37.25	205	89	Average
5042	60.45	60.31	74	-13.55	31.24	6.15	37.25	205	89	Peak
5270	89.11	88.72			31.41	6.25	37.27	205	89	Average
5270	99.24	98.85			31.41	6.25	37.27	205	89	Peak
5446	38.89	38.12	54	-15.11	31.56	6.34	37.13	205	89	Average
5446	60.32	59.55	74	-13.68	31.56	6.34	37.13	205	89	Peak
Antenna Polarity & Test Distance: Vertical at 3 m										
Frequency (MHz)	Emission Level (dBuV/m)	Read Level (dBuV)	Limit (dBuV/m)	Margin (dB)	Antenna Factor (dB/m)	Cable Loss (dB)	Preamp Factor (dB)	Antenna Height (cm)	Table Angle (Degree)	Remark
5002	38.29	38.19	54	-15.71	31.2	6.13	37.23	114	333	Average
5002	59.41	59.31	74	-14.59	31.2	6.13	37.23	114	333	Peak
5270	86.71	86.32			31.41	6.25	37.27	114	333	Average
5270	96.74	96.35			31.41	6.25	37.27	114	333	Peak
5442	38.65	37.89	54	-15.35	31.55	6.34	37.13	114	333	Average
5442	59.43	58.67	74	-14.57	31.55	6.34	37.13	114	333	Peak

Remarks:

- Emission Level = Read Level + Antenna Factor + Cable Loss - Preamp Factor  
Margin value = Emission level – Limit value
- 5270 MHz: Fundamental Frequency

EUT Test Condition		Measurement Detail	
Channel	Channel 62	Frequency Range	1 GHz ~ 40 GHz
Input Power	120 Vac, 60 Hz	Detector Function	Peak (PK) Average (AV)
Environmental Conditions	25 deg. C, 65 % RH	Tested By	Toby Tian

Antenna Polarity & Test Distance: Horizontal at 3 m										
Frequency (MHz)	Emission Level (dBuV/m)	Read Level (dBuV)	Limit (dBuV/m)	Margin (dB)	Antenna Factor (dB/m)	Cable Loss (dB)	Preamp Factor (dB)	Antenna Height (cm)	Table Angle (Degree)	Remark
5044	38.6	38.46	54	-15.4	31.24	6.15	37.25	191	77	Average
5044	59.86	59.72	74	-14.14	31.24	6.15	37.25	191	77	Peak
5310	89.2	88.67			31.45	6.27	37.19	191	77	Average
5310	99.46	98.93			31.45	6.27	37.19	191	77	Peak
5350	44.93	44.34	54	-9.07	31.48	6.29	37.18	191	77	Average
5350	62.33	61.74	74	-11.67	31.48	6.29	37.18	191	77	Peak
Antenna Polarity & Test Distance: Vertical at 3 m										
Frequency (MHz)	Emission Level (dBuV/m)	Read Level (dBuV)	Limit (dBuV/m)	Margin (dB)	Antenna Factor (dB/m)	Cable Loss (dB)	Preamp Factor (dB)	Antenna Height (cm)	Table Angle (Degree)	Remark
5034	38.58	38.44	54	-15.42	31.23	6.15	37.24	158	332	Average
5034	60.28	60.14	74	-13.72	31.23	6.15	37.24	158	332	Peak
5310	85.73	85.2			31.45	6.27	37.19	158	332	Average
5310	96.27	95.74			31.45	6.27	37.19	158	332	Peak
5396	40.79	40.14	54	-13.21	31.52	6.31	37.18	158	332	Average
5396	59.56	58.91	74	-14.44	31.52	6.31	37.18	158	332	Peak

Remarks:

- Emission Level = Read Level + Antenna Factor + Cable Loss - Preamp Factor  
Margin value = Emission level – Limit value
- 5310 MHz: Fundamental Frequency

EUT Test Condition		Measurement Detail	
Channel	Channel 102	Frequency Range	1 GHz ~ 40 GHz
Input Power	120 Vac, 60 Hz	Detector Function	Peak (PK) Average (AV)
Environmental Conditions	25 deg. C, 65 % RH	Tested By	Gavin Wu

Antenna Polarity & Test Distance: Horizontal at 3 m										
Frequency (MHz)	Emission Level (dBuV/m)	Read Level (dBuV)	Limit (dBuV/m)	Margin (dB)	Antenna Factor (dB/m)	Cable Loss (dB)	Preamp Factor (dB)	Antenna Height (cm)	Table Angle (Degree)	Remark
5430	40.59	39.85	54	-13.41	31.55	6.32	37.13	203	310	Average
5430	61.47	60.73	74	-12.53	31.55	6.32	37.13	203	310	Peak
5470	61.72	60.89	68.2	-6.48	31.57	6.34	37.08	203	310	Peak
5510	88.65	87.75			31.6	6.36	37.06	203	310	Average
5510	99.48	98.58			31.6	6.36	37.06	203	310	Peak
5725	60.63	59.35	68.2	-7.57	31.96	6.75	37.43	203	310	Peak
Antenna Polarity & Test Distance: Vertical at 3 m										
Frequency (MHz)	Emission Level (dBuV/m)	Read Level (dBuV)	Limit (dBuV/m)	Margin (dB)	Antenna Factor (dB/m)	Cable Loss (dB)	Preamp Factor (dB)	Antenna Height (cm)	Table Angle (Degree)	Remark
5440	39.13	38.37	54	-14.87	31.55	6.34	37.13	208	14	Average
5440	60.25	59.49	74	-13.75	31.55	6.34	37.13	208	14	Peak
5470	59.03	58.2	68.2	-9.17	31.57	6.34	37.08	208	14	Peak
5510	85.7	84.8			31.6	6.36	37.06	208	14	Average
5510	96.42	95.52			31.6	6.36	37.06	208	14	Peak
5725	61.86	60.58	68.2	-6.34	31.96	6.75	37.43	208	14	Peak

Remarks:

- Emission Level = Read Level + Antenna Factor + Cable Loss - Preamp Factor  
Margin value = Emission level – Limit value
- 5510 MHz: Fundamental Frequency
- 5470 MHz & 5725 MHz: Out of Restricted Band

EUT Test Condition		Measurement Detail	
Channel	Channel 110	Frequency Range	1 GHz ~ 40 GHz
Input Power	120 Vac, 60 Hz	Detector Function	Peak (PK) Average (AV)
Environmental Conditions	25 deg. C, 65 % RH	Tested By	Gavin Wu

Antenna Polarity & Test Distance: Horizontal at 3 m										
Frequency (MHz)	Emission Level (dBuV/m)	Read Level (dBuV)	Limit (dBuV/m)	Margin (dB)	Antenna Factor (dB/m)	Cable Loss (dB)	Preamp Factor (dB)	Antenna Height (cm)	Table Angle (Degree)	Remark
5384	39.4	38.76	54	-14.6	31.51	6.31	37.18	205	311	Average
5384	60.63	59.99	74	-13.37	31.51	6.31	37.18	205	311	Peak
5470	59.77	58.94	68.2	-8.43	31.57	6.34	37.08	205	311	Peak
5550	88.82	87.81			31.68	6.42	37.09	205	311	Average
5550	99.9	98.89			31.68	6.42	37.09	205	311	Peak
5725	59.68	58.4	68.2	-8.52	31.96	6.75	37.43	205	311	Peak
Antenna Polarity & Test Distance: Vertical at 3 m										
Frequency (MHz)	Emission Level (dBuV/m)	Read Level (dBuV)	Limit (dBuV/m)	Margin (dB)	Antenna Factor (dB/m)	Cable Loss (dB)	Preamp Factor (dB)	Antenna Height (cm)	Table Angle (Degree)	Remark
5432	38.91	38.17	54	-15.09	31.55	6.32	37.13	207	13	Average
5432	60.49	59.75	74	-13.51	31.55	6.32	37.13	207	13	Peak
5470	58.83	58	68.2	-9.37	31.57	6.34	37.08	207	13	Peak
5550	85.43	84.42			31.68	6.42	37.09	207	13	Average
5550	96.3	95.29			31.68	6.42	37.09	207	13	Peak
5725	60.94	59.66	68.2	-7.26	31.96	6.75	37.43	207	13	Peak

Remarks:

- Emission Level = Read Level + Antenna Factor + Cable Loss - Preamp Factor  
Margin value = Emission level – Limit value
- 5550 MHz: Fundamental Frequency
- 5470 MHz & 5725 MHz: Out of Restricted Band



EUT Test Condition		Measurement Detail	
Channel	Channel 134	Frequency Range	1 GHz ~ 40 GHz
Input Power	120 Vac, 60 Hz	Detector Function	Peak (PK) Average (AV)
Environmental Conditions	25 deg. C, 65 % RH	Tested By	Gavin Wu

Antenna Polarity & Test Distance: Horizontal at 3 m										
Frequency (MHz)	Emission Level (dBuV/m)	Read Level (dBuV)	Limit (dBuV/m)	Margin (dB)	Antenna Factor (dB/m)	Cable Loss (dB)	Preamp Factor (dB)	Antenna Height (cm)	Table Angle (Degree)	Remark
5356	38.89	38.3	54	-15.11	31.48	6.29	37.18	207	314	Average
5356	60.75	60.16	74	-13.25	31.48	6.29	37.18	207	314	Peak
5470	58.01	57.18	68.2	-10.19	31.57	6.34	37.08	207	314	Peak
5670	88.04	86.88			31.88	6.62	37.34	207	314	Average
5670	99.34	98.18			31.88	6.62	37.34	207	314	Peak
5725	59.12	57.84	68.2	-9.08	31.96	6.75	37.43	207	314	Peak
Antenna Polarity & Test Distance: Vertical at 3 m										
Frequency (MHz)	Emission Level (dBuV/m)	Read Level (dBuV)	Limit (dBuV/m)	Margin (dB)	Antenna Factor (dB/m)	Cable Loss (dB)	Preamp Factor (dB)	Antenna Height (cm)	Table Angle (Degree)	Remark
5402	38.5	37.84	54	-15.5	31.52	6.32	37.18	193	10	Average
5402	60.95	60.29	74	-13.05	31.52	6.32	37.18	193	10	Peak
5470	59.87	59.04	68.2	-8.33	31.57	6.34	37.08	193	10	Peak
5670	85.47	84.31			31.88	6.62	37.34	193	10	Average
5670	96.4	95.24			31.88	6.62	37.34	193	10	Peak
5725	60.68	59.4	68.2	-7.52	31.96	6.75	37.43	193	10	Peak

Remarks:

- Emission Level = Read Level + Antenna Factor + Cable Loss - Preamp Factor  
Margin value = Emission level – Limit value
- 5670 MHz: Fundamental Frequency
- 5470 MHz & 5725 MHz: Out of Restricted Band

EUT Test Condition		Measurement Detail	
Channel	Channel 151	Frequency Range	1 GHz ~ 40 GHz
Input Power	120 Vac, 60 Hz	Detector Function	Peak (PK) Average (AV)
Environmental Conditions	25 deg. C, 65 % RH	Tested By	Toby Tian

Antenna Polarity & Test Distance: Horizontal at 3 m										
Frequency (MHz)	Emission Level (dBuV/m)	Read Level (dBuV)	Limit (dBuV/m)	Margin (dB)	Antenna Factor (dB/m)	Cable Loss (dB)	Preamp Factor (dB)	Antenna Height (cm)	Table Angle (Degree)	Remark
*5714	60.55	59.36	68.2	-7.65	31.93	6.69	37.43	106	60	Peak
*5725	63.44	62.16	78.2	-14.76	31.96	6.75	37.43	106	60	Peak
5755	88.74	87.45			32.01	6.75	37.47	106	60	Average
5755	99.19	97.9			32.01	6.75	37.47	106	60	Peak
*5850	60.21	58.69	78.2	-17.99	32.15	6.88	37.51	106	60	Peak
*5861	60.13	58.5	68.2	-8.07	32.18	6.95	37.5	106	60	Peak

Antenna Polarity & Test Distance: Vertical at 3 m										
Frequency (MHz)	Emission Level (dBuV/m)	Read Level (dBuV)	Limit (dBuV/m)	Margin (dB)	Antenna Factor (dB/m)	Cable Loss (dB)	Preamp Factor (dB)	Antenna Height (cm)	Table Angle (Degree)	Remark
*5714	59.87	58.68	68.2	-8.33	31.93	6.69	37.43	165	16	Peak
*5725	59.85	58.57	78.2	-18.35	31.96	6.75	37.43	165	16	Peak
5755	86.52	85.23			32.01	6.75	37.47	165	16	Average
5755	96.82	95.53			32.01	6.75	37.47	165	16	Peak
*5850	58.49	56.97	78.2	-19.71	32.15	6.88	37.51	165	16	Peak
*5861	58.41	56.78	68.2	-9.79	32.18	6.95	37.5	165	16	Peak

Remarks:

- Emission Level = Read Level + Antenna Factor + Cable Loss - Preamp Factor  
Margin value = Emission level – Limit value
- 5755 MHz: Fundamental Frequency
- \*: Out of Restricted Band

EUT Test Condition		Measurement Detail	
Channel	Channel 159	Frequency Range	1 GHz ~ 40 GHz
Input Power	120 Vac, 60 Hz	Detector Function	Peak (PK) Average (AV)
Environmental Conditions	25 deg. C, 65 % RH	Tested By	Toby Tian

Antenna Polarity & Test Distance: Horizontal at 3 m										
Frequency (MHz)	Emission Level (dBuV/m)	Read Level (dBuV)	Limit (dBuV/m)	Margin (dB)	Antenna Factor (dB/m)	Cable Loss (dB)	Preamp Factor (dB)	Antenna Height (cm)	Table Angle (Degree)	Remark
*5714	58.65	57.46	68.2	-9.55	31.93	6.69	37.43	104	71	Peak
*5725	60.24	58.96	78.2	-17.96	31.96	6.75	37.43	104	71	Peak
5795	88.89	87.54			32.07	6.82	37.54	104	71	Average
5795	99.3	97.95			32.07	6.82	37.54	104	71	Peak
*5850	60.71	59.19	78.2	-17.49	32.15	6.88	37.51	104	71	Peak
*5861	60.66	59.03	68.2	-7.54	32.18	6.95	37.5	104	71	Peak
Antenna Polarity & Test Distance: Vertical at 3 m										
Frequency (MHz)	Emission Level (dBuV/m)	Read Level (dBuV)	Limit (dBuV/m)	Margin (dB)	Antenna Factor (dB/m)	Cable Loss (dB)	Preamp Factor (dB)	Antenna Height (cm)	Table Angle (Degree)	Remark
*5714	59.14	57.95	68.2	-9.06	31.93	6.69	37.43	121	8	Peak
*5725	61.4	60.18	78.2	-16.8	31.96	6.69	37.43	121	8	Peak
5795	86.63	85.28			32.07	6.82	37.54	121	8	Average
5795	96.84	95.49			32.07	6.82	37.54	121	8	Peak
*5850	59.39	57.87	78.2	-18.81	32.15	6.88	37.51	121	8	Peak
*5861	60.49	58.86	68.2	-7.71	32.18	6.95	37.5	121	8	Peak

Remarks:

- Emission Level = Read Level + Antenna Factor + Cable Loss - Preamp Factor  
Margin value = Emission level – Limit value
- 5795 MHz: Fundamental Frequency
- \*: Out of Restricted Band

### 802.11ac (VHT80)

EUT Test Condition		Measurement Detail	
Channel	Channel 42	Frequency Range	1 GHz ~ 40 GHz
Input Power	120 Vac, 60 Hz	Detector Function	Peak (PK) Average (AV)
Environmental Conditions	25 deg. C, 65 % RH	Tested By	Toby Tian

#### Antenna Polarity & Test Distance: Horizontal at 3 m

Frequency (MHz)	Emission Level (dBuV/m)	Read Level (dBuV)	Limit (dBuV/m)	Margin (dB)	Antenna Factor (dB/m)	Cable Loss (dB)	Preamp Factor (dB)	Antenna Height (cm)	Table Angle (Degree)	Remark
5138	44.44	44.23	54	-9.56	31.31	6.2	37.3	111	49	Average
5138	61.08	60.87	74	-12.92	31.31	6.2	37.3	111	49	Peak
5210	79.65	79.4			31.37	6.24	37.36	111	49	Average
5210	93.34	93.09			31.37	6.24	37.36	111	49	Peak
5352	38.84	38.25	54	-15.16	31.48	6.29	37.18	111	49	Average
5352	61.42	60.83	74	-12.58	31.48	6.29	37.18	111	49	Peak

#### Antenna Polarity & Test Distance: Vertical at 3 m

Frequency (MHz)	Emission Level (dBuV/m)	Read Level (dBuV)	Limit (dBuV/m)	Margin (dB)	Antenna Factor (dB/m)	Cable Loss (dB)	Preamp Factor (dB)	Antenna Height (cm)	Table Angle (Degree)	Remark
5012	40.36	40.25	54	-13.64	31.21	6.13	37.23	100	309	Average
5012	59.9	59.79	74	-14.1	31.21	6.13	37.23	100	309	Peak
5210	77.52	77.27			31.37	6.24	37.36	100	309	Average
5210	91.05	90.8			31.37	6.24	37.36	100	309	Peak
5442	38.87	38.11	54	-15.13	31.55	6.34	37.13	100	309	Average
5442	60.19	59.43	74	-13.81	31.55	6.34	37.13	100	309	Peak

Remarks:

- Emission Level = Read Level + Antenna Factor + Cable Loss - Preamp Factor  
Margin value = Emission level – Limit value
- 5210 MHz: Fundamental Frequency

EUT Test Condition		Measurement Detail	
Channel	Channel 58	Frequency Range	1 GHz ~ 40 GHz
Input Power	120 Vac, 60 Hz	Detector Function	Peak (PK) Average (AV)
Environmental Conditions	25 deg. C, 65 % RH	Tested By	Toby Tian

Antenna Polarity & Test Distance: Horizontal at 3 m										
Frequency (MHz)	Emission Level (dBuV/m)	Read Level (dBuV)	Limit (dBuV/m)	Margin (dB)	Antenna Factor (dB/m)	Cable Loss (dB)	Preamp Factor (dB)	Antenna Height (cm)	Table Angle (Degree)	Remark
5094	38.75	38.56	54	-15.25	31.28	6.19	37.28	200	99	Average
5094	59.54	59.35	74	-14.46	31.28	6.19	37.28	200	99	Peak
5290	84.11	83.64			31.43	6.27	37.23	200	99	Average
5290	94.36	93.89			31.43	6.27	37.23	200	99	Peak
5358	45.86	45.25	54	-8.14	31.48	6.31	37.18	200	99	Average
5358	60.83	60.22	74	-13.17	31.48	6.31	37.18	200	99	Peak
Antenna Polarity & Test Distance: Vertical at 3 m										
Frequency (MHz)	Emission Level (dBuV/m)	Read Level (dBuV)	Limit (dBuV/m)	Margin (dB)	Antenna Factor (dB/m)	Cable Loss (dB)	Preamp Factor (dB)	Antenna Height (cm)	Table Angle (Degree)	Remark
5146	38.7	38.5	54	-15.3	31.32	6.2	37.32	177	307	Average
5146	59.73	59.53	74	-14.27	31.32	6.2	37.32	177	307	Peak
5290	80.57	80.1			31.43	6.27	37.23	177	307	Average
5290	90.68	90.21			31.43	6.27	37.23	177	307	Peak
5366	41.59	40.97	54	-12.41	31.49	6.31	37.18	177	307	Average
5366	61.98	61.36	74	-12.02	31.49	6.31	37.18	177	307	Peak

Remarks:

- Emission Level = Read Level + Antenna Factor + Cable Loss - Preamp Factor  
Margin value = Emission level – Limit value
- 5290 MHz: Fundamental Frequency

EUT Test Condition		Measurement Detail	
Channel	Channel 106	Frequency Range	1 GHz ~ 40 GHz
Input Power	120 Vac, 60 Hz	Detector Function	Peak (PK) Average (AV)
Environmental Conditions	25 deg. C, 65 % RH	Tested By	Gavin Wu

Antenna Polarity & Test Distance: Horizontal at 3 m										
Frequency (MHz)	Emission Level (dBuV/m)	Read Level (dBuV)	Limit (dBuV/m)	Margin (dB)	Antenna Factor (dB/m)	Cable Loss (dB)	Preamp Factor (dB)	Antenna Height (cm)	Table Angle (Degree)	Remark
5450	43.97	43.15	54	-10.03	31.56	6.34	37.08	205	312	Average
5450	61.43	60.61	74	-12.57	31.56	6.34	37.08	205	312	Peak
5470	59.23	58.4	68.2	-8.97	31.57	6.34	37.08	205	312	Peak
5530	82.15	81.19			31.63	6.42	37.09	205	312	Average
5530	94.33	93.37			31.63	6.42	37.09	205	312	Peak
5725	59.65	58.37	68.2	-8.55	31.96	6.75	37.43	205	312	Peak
Antenna Polarity & Test Distance: Vertical at 3 m										
Frequency (MHz)	Emission Level (dBuV/m)	Read Level (dBuV)	Limit (dBuV/m)	Margin (dB)	Antenna Factor (dB/m)	Cable Loss (dB)	Preamp Factor (dB)	Antenna Height (cm)	Table Angle (Degree)	Remark
5456	41.77	40.95	54	-12.23	31.56	6.34	37.08	192	21	Average
5456	60.68	59.86	74	-13.32	31.56	6.34	37.08	192	21	Peak
5470	58.31	57.48	68.2	-9.89	31.57	6.34	37.08	192	21	Peak
5530	79.57	78.61			31.63	6.42	37.09	192	21	Average
5530	90.21	89.25			31.63	6.42	37.09	192	21	Peak
5725	60.5	59.22	68.2	-7.7	31.96	6.75	37.43	192	21	Peak

Remarks:

- Emission Level = Read Level + Antenna Factor + Cable Loss - Preamp Factor  
Margin value = Emission level – Limit value
- 5530 MHz: Fundamental Frequency
- 5470 MHz & 5725 MHz: Out of Restricted Band

EUT Test Condition		Measurement Detail	
Channel	Channel 122	Frequency Range	1 GHz ~ 40 GHz
Input Power	120 Vac, 60 Hz	Detector Function	Peak (PK) Average (AV)
Environmental Conditions	25 deg. C, 65 % RH	Tested By	Gavin Wu

Antenna Polarity & Test Distance: Horizontal at 3 m										
Frequency (MHz)	Emission Level (dBuV/m)	Read Level (dBuV)	Limit (dBuV/m)	Margin (dB)	Antenna Factor (dB/m)	Cable Loss (dB)	Preamp Factor (dB)	Antenna Height (cm)	Table Angle (Degree)	Remark
5356	38.26	37.67	54	-15.74	31.48	6.29	37.18	170	233	Average
5356	59.75	59.16	74	-14.25	31.48	6.29	37.18	170	233	Peak
5470	58.3	57.47	68.2	-9.9	31.57	6.34	37.08	170	233	Peak
5610	83.66	82.55			31.77	6.56	37.22	170	233	Average
5610	94.88	93.77			31.77	6.56	37.22	170	233	Peak
5725	58.7	57.42	68.2	-9.5	31.96	6.75	37.43	160	212	Peak
Antenna Polarity & Test Distance: Vertical at 3 m										
Frequency (MHz)	Emission Level (dBuV/m)	Read Level (dBuV)	Limit (dBuV/m)	Margin (dB)	Antenna Factor (dB/m)	Cable Loss (dB)	Preamp Factor (dB)	Antenna Height (cm)	Table Angle (Degree)	Remark
5356	37.15	36.56	54	-16.85	31.48	6.29	37.18	126	211	Average
5356	58.67	58.08	74	-15.33	31.48	6.29	37.18	126	211	Peak
5470	57.05	56.22	68.2	-11.15	31.57	6.34	37.08	126	211	Peak
5610	80.12	79.01			31.77	6.56	37.22	126	211	Average
5610	90.88	89.77			31.77	6.56	37.22	126	211	Peak
5725	59.11	57.83	68.2	-9.09	31.96	6.75	37.43	126	211	Peak

Remarks:

1. Emission Level = Read Level + Antenna Factor + Cable Loss - Preamp Factor  
Margin value = Emission level – Limit value
2. 5610 MHz: Fundamental Frequency
3. 5470 MHz & 5725 MHz: Out of Restricted Band

EUT Test Condition		Measurement Detail	
Channel	Channel 155	Frequency Range	1 GHz ~ 40 GHz
Input Power	120 Vac, 60 Hz	Detector Function	Peak (PK) Average (AV)
Environmental Conditions	25 deg. C, 65 % RH	Tested By	Toby Tian

Antenna Polarity & Test Distance: Horizontal at 3 m										
Frequency (MHz)	Emission Level (dBuV/m)	Read Level (dBuV)	Limit (dBuV/m)	Margin (dB)	Antenna Factor (dB/m)	Cable Loss (dB)	Preamp Factor (dB)	Antenna Height (cm)	Table Angle (Degree)	Remark
*5714	59.36	58.17	68.2	-8.84	31.93	6.69	37.43	103	52	Peak
*5725	60.56	59.28	78.2	-17.64	31.96	6.75	37.43	103	52	Peak
5775	83.62	82.26			32.04	6.82	37.5	103	52	Average
5775	93.98	92.62			32.04	6.82	37.5	103	52	Peak
*5850	60.17	58.65	78.2	-18.03	32.15	6.88	37.51	103	52	Peak
*5861	61.28	59.65	68.2	-6.92	32.18	6.95	37.5	103	52	Peak
Antenna Polarity & Test Distance: Vertical at 3 m										
Frequency (MHz)	Emission Level (dBuV/m)	Read Level (dBuV)	Limit (dBuV/m)	Margin (dB)	Antenna Factor (dB/m)	Cable Loss (dB)	Preamp Factor (dB)	Antenna Height (cm)	Table Angle (Degree)	Remark
*5714	59.72	58.53	68.2	-8.48	31.93	6.69	37.43	166	29	Peak
*5725	60.42	59.14	78.2	-17.78	31.96	6.75	37.43	166	29	Peak
5775	81.36	80			32.04	6.82	37.5	166	29	Average
5775	91.68	90.32			32.04	6.82	37.5	166	29	Peak
*5850	60.9	59.38	78.2	-17.3	32.15	6.88	37.51	166	29	Peak
*5861	60.92	59.29	68.2	-7.28	32.18	6.95	37.5	166	29	Peak

Remarks:

- Emission Level = Read Level + Antenna Factor + Cable Loss - Preamp Factor  
Margin value = Emission level – Limit value
- 5775 MHz: Fundamental Frequency
- \*: Out of Restricted Band



### 9 kHz ~ 30 MHz DATA:

The amplitude of spurious emissions attenuated more than 20 dB below the permissible value is not required to be report.

### 30 MHz ~ 1 GHz WORST-CASE DATA:

#### Mode A

#### 802.11a

EUT Test Condition		Measurement Detail	
Channel	Channel 36	Frequency Range	30 MHz ~ 1 GHz
Input Power	120 Vac, 60 Hz	Detector Function	Peak (PK) Quasi-peak (QP)
Environmental Conditions	25 deg. C, 65 % RH	Tested By	Toby Tian

Antenna Polarity & Test Distance: Horizontal at 3 m										
Frequency (MHz)	Emission Level (dBuV/m)	Read Level (dBuV)	Limit (dBuV/m)	Margin (dB)	Antenna Factor (dB/m)	Cable Loss (dB)	Preamp Factor (dB)	Antenna Height (cm)	Table Angle (Degree)	Remark
34.85	25.66	43.33	40	-14.34	12.79	0.6	31.06	123	76	Peak
127	39.93	59.2	43.5	-3.57	11.48	1.14	31.89	113	220	Peak
184.23	24.11	44.19	43.5	-19.39	10.46	1.23	31.77	139	294	Peak
327.79	16.92	33.43	46	-29.08	13.61	1.71	31.83	111	158	Peak
449.04	19.56	33.25	46	-26.44	16.31	1.98	31.98	101	225	Peak
571.26	23.29	34.21	46	-22.71	18.95	2.21	32.08	135	76	Peak
Antenna Polarity & Test Distance: Vertical at 3 m										
Frequency (MHz)	Emission Level (dBuV/m)	Read Level (dBuV)	Limit (dBuV/m)	Margin (dB)	Antenna Factor (dB/m)	Cable Loss (dB)	Preamp Factor (dB)	Antenna Height (cm)	Table Angle (Degree)	Remark
33.88	37.59	55.44	40	-2.41	12.63	0.6	31.08	106	130	Peak
122.15	37.67	57.27	43.5	-5.83	11.15	1.15	31.9	140	264	Peak
222.06	18.06	38.12	46	-27.94	10.3	1.38	31.74	102	257	Peak
369.5	18.71	34.2	46	-27.29	14.61	1.82	31.92	101	225	Peak
517.91	21.43	33.15	46	-24.57	17.73	2.12	31.57	114	215	Peak
634.31	22.78	32.56	46	-23.22	20.02	2.32	32.12	104	4	Peak

Remarks:

- Emission Level = Read Level + Antenna Factor + Cable Loss - Preamp Factor  
Margin value = Emission level – Limit value

802.11a

EUT Test Condition		Measurement Detail	
Channel	Channel 64	Frequency Range	30 MHz ~ 1 GHz
Input Power	120 Vac, 60 Hz	Detector Function	Peak (PK) Quasi-peak (QP)
Environmental Conditions	25 deg. C, 65 % RH	Tested By	Toby Tian

Antenna Polarity & Test Distance: Horizontal at 3 m										
Frequency (MHz)	Emission Level (dBuV/m)	Read Level (dBuV)	Limit (dBuV/m)	Margin (dB)	Antenna Factor (dB/m)	Cable Loss (dB)	Preamp Factor (dB)	Antenna Height (cm)	Table Angle (Degree)	Remark
34.85	26.23	43.9	40	-13.77	12.79	0.6	31.06	113	153	Peak
127	39.95	59.22	43.5	-3.55	11.48	1.14	31.89	126	353	Peak
183.26	23.65	43.68	43.5	-19.85	10.53	1.23	31.79	140	101	Peak
333.61	18.2	34.54	46	-27.8	13.75	1.72	31.81	116	187	Peak
435.46	19.78	33.78	46	-26.22	16.04	1.96	32	111	49	Peak
535.37	20.93	32.36	46	-25.07	18.13	2.15	31.71	114	87	Peak
Antenna Polarity & Test Distance: Vertical at 3 m										
Frequency (MHz)	Emission Level (dBuV/m)	Read Level (dBuV)	Limit (dBuV/m)	Margin (dB)	Antenna Factor (dB/m)	Cable Loss (dB)	Preamp Factor (dB)	Antenna Height (cm)	Table Angle (Degree)	Remark
32.91	37.25	55.27	40	-2.75	12.47	0.6	31.09	121	122	Peak
120.21	37.54	57.26	43.5	-5.96	11.02	1.16	31.9	112	207	Peak
221.09	18.24	38.32	46	-27.76	10.26	1.38	31.72	119	255	Peak
381.14	18.03	33.24	46	-27.97	14.89	1.86	31.96	100	236	Peak
475.23	19.93	32.93	46	-26.07	16.83	2.04	31.87	119	137	Peak
594.54	22.57	33.03	46	-23.43	19.48	2.25	32.19	100	257	Peak

Remarks:

- Emission Level = Read Level + Antenna Factor + Cable Loss - Preamp Factor  
Margin value = Emission level – Limit value

### 802.11ac (VHT80)

EUT Test Condition		Measurement Detail	
Channel	Channel 106	Frequency Range	30 MHz ~ 1 GHz
Input Power	120 Vac, 60 Hz	Detector Function	Peak (PK) Quasi-peak (QP)
Environmental Conditions	25 deg. C, 65 % RH	Tested By	Toby Tian

#### Antenna Polarity & Test Distance: Horizontal at 3 m

Frequency (MHz)	Emission Level (dBuV/m)	Read Level (dBuV)	Limit (dBuV/m)	Margin (dB)	Antenna Factor (dB/m)	Cable Loss (dB)	Preamp Factor (dB)	Antenna Height (cm)	Table Angle (Degree)	Remark
33.88	28.25	46.1	40	-11.75	12.63	0.6	31.08	119	148	Peak
126.03	39.3	58.63	43.5	-4.2	11.42	1.14	31.89	111	56	Peak
184.23	24.03	44.11	43.5	-19.47	10.46	1.23	31.77	105	233	Peak
304.51	16.12	33.3	46	-29.88	13.06	1.65	31.89	124	81	Peak
454.86	19.45	33.02	46	-26.55	16.43	1.99	31.99	109	256	Peak
559.62	22.3	33.49	46	-23.7	18.68	2.19	32.06	134	253	Peak

#### Antenna Polarity & Test Distance: Vertical at 3 m

Frequency (MHz)	Emission Level (dBuV/m)	Read Level (dBuV)	Limit (dBuV/m)	Margin (dB)	Antenna Factor (dB/m)	Cable Loss (dB)	Preamp Factor (dB)	Antenna Height (cm)	Table Angle (Degree)	Remark
32.91	37.05	55.07	40	-2.95	12.47	0.6	31.09	101	354	Peak
121.18	37.7	57.35	43.5	-5.8	11.09	1.16	31.9	120	3	Peak
224	18.17	38.17	46	-27.83	10.38	1.39	31.77	135	78	Peak
381.14	19.03	34.24	46	-26.97	14.89	1.86	31.96	103	37	Peak
476.2	19.55	32.53	46	-26.45	16.85	2.04	31.87	124	98	Peak
579.99	23.07	33.82	46	-22.93	19.15	2.22	32.12	136	175	Peak

Remarks:

- Emission Level = Read Level + Antenna Factor + Cable Loss - Preamp Factor  
Margin value = Emission level – Limit value

802.11a

EUT Test Condition		Measurement Detail	
Channel	Channel 165	Frequency Range	30 MHz ~ 1 GHz
Input Power	120 Vac, 60 Hz	Detector Function	Peak (PK) Quasi-peak (QP)
Environmental Conditions	25 deg. C, 65 % RH	Tested By	Toby Tian

Antenna Polarity & Test Distance: Horizontal at 3 m										
Frequency (MHz)	Emission Level (dBuV/m)	Read Level (dBuV)	Limit (dBuV/m)	Margin (dB)	Antenna Factor (dB/m)	Cable Loss (dB)	Preamp Factor (dB)	Antenna Height (cm)	Table Angle (Degree)	Remark
34.85	26.52	44.19	40	-13.48	12.79	0.6	31.06	102	172	Peak
127	39.54	58.81	43.5	-3.96	11.48	1.14	31.89	127	306	Peak
183.26	23.75	43.78	43.5	-19.75	10.53	1.23	31.79	100	293	Peak
306.45	17.73	34.89	46	-28.27	13.1	1.65	31.91	109	319	Peak
426.73	18.87	33.07	46	-27.13	15.87	1.95	32.02	121	272	Peak
528.58	21.81	33.38	46	-24.19	17.97	2.14	31.68	125	140	Peak

Antenna Polarity & Test Distance: Vertical at 3 m										
Frequency (MHz)	Emission Level (dBuV/m)	Read Level (dBuV)	Limit (dBuV/m)	Margin (dB)	Antenna Factor (dB/m)	Cable Loss (dB)	Preamp Factor (dB)	Antenna Height (cm)	Table Angle (Degree)	Remark
32.91	37.08	55.1	40	-2.92	12.47	0.6	31.09	120	164	Peak
120.21	37.94	57.66	43.5	-5.56	11.02	1.16	31.9	140	198	Peak
222.06	18.29	38.35	46	-27.71	10.3	1.38	31.74	136	79	Peak
414.12	18.86	33.31	46	-27.14	15.62	1.94	32.01	135	90	Peak
516.94	21.28	33.03	46	-24.72	17.71	2.12	31.58	107	130	Peak
591.63	22.99	33.5	46	-23.01	19.41	2.24	32.16	104	3	Peak

Remarks:

- Emission Level = Read Level + Antenna Factor + Cable Loss - Preamp Factor  
Margin value = Emission level – Limit value

**Mode C**

**802.11a**

EUT Test Condition		Measurement Detail	
Channel	Channel 36	Frequency Range	30 MHz ~ 1 GHz
Input Power	120 Vac, 60 Hz	Detector Function	Peak (PK) Quasi-peak (QP)
Environmental Conditions	25 deg. C, 65 % RH	Tested By	Toby Tian

Antenna Polarity & Test Distance: Horizontal at 3 m										
Frequency (MHz)	Emission Level (dBuV/m)	Read Level (dBuV)	Limit (dBuV/m)	Margin (dB)	Antenna Factor (dB/m)	Cable Loss (dB)	Preamp Factor (dB)	Antenna Height (cm)	Table Angle (Degree)	Remark
34.85	25.18	42.85	40	-14.82	12.79	0.6	31.06	116	128	Peak
127	39.83	59.1	43.5	-3.67	11.48	1.14	31.89	124	349	Peak
183.26	23.75	43.78	43.5	-19.75	10.53	1.23	31.79	121	130	Peak
334.58	16.8	33.1	46	-29.2	13.78	1.73	31.81	106	121	Peak
470.38	20.23	33.36	46	-25.77	16.73	2.03	31.89	116	33	Peak
538.28	21.3	32.67	46	-24.7	18.19	2.16	31.72	107	201	Peak

Antenna Polarity & Test Distance: Vertical at 3 m										
Frequency (MHz)	Emission Level (dBuV/m)	Read Level (dBuV)	Limit (dBuV/m)	Margin (dB)	Antenna Factor (dB/m)	Cable Loss (dB)	Preamp Factor (dB)	Antenna Height (cm)	Table Angle (Degree)	Remark
32.91	37.15	55.17	40	-2.85	12.47	0.6	31.09	129	48	Peak
121.18	37.41	57.06	43.5	-6.09	11.09	1.16	31.9	114	332	Peak
222.06	18.25	38.31	46	-27.75	10.3	1.38	31.74	101	194	Peak
379.2	18.15	33.4	46	-27.85	14.84	1.86	31.95	102	10	Peak
461.65	19.99	33.39	46	-26.01	16.56	2.01	31.97	129	306	Peak
585.81	23.45	34.06	46	-22.55	19.28	2.24	32.13	113	235	Peak

Remarks:

- Emission Level = Read Level + Antenna Factor + Cable Loss - Preamp Factor  
Margin value = Emission level – Limit value

802.11a

EUT Test Condition		Measurement Detail	
Channel	Channel 64	Frequency Range	30 MHz ~ 1 GHz
Input Power	120 Vac, 60 Hz	Detector Function	Peak (PK) Quasi-peak (QP)
Environmental Conditions	25 deg. C, 65 % RH	Tested By	Toby Tian

Antenna Polarity & Test Distance: Horizontal at 3 m										
Frequency (MHz)	Emission Level (dBuV/m)	Read Level (dBuV)	Limit (dBuV/m)	Margin (dB)	Antenna Factor (dB/m)	Cable Loss (dB)	Preamp Factor (dB)	Antenna Height (cm)	Table Angle (Degree)	Remark
33.88	27.31	45.16	40	-12.69	12.63	0.6	31.08	109	122	Peak
126.03	39.46	58.79	43.5	-4.04	11.42	1.14	31.89	130	237	Peak
182.29	22.63	42.62	43.5	-20.87	10.6	1.22	31.81	140	268	Peak
376.29	18.33	33.65	46	-27.67	14.77	1.85	31.94	134	4	Peak
516.94	21.2	32.95	46	-24.8	17.71	2.12	31.58	104	318	Peak
577.08	22.76	33.57	46	-23.24	19.08	2.22	32.11	127	348	Peak

Antenna Polarity & Test Distance: Vertical at 3 m										
Frequency (MHz)	Emission Level (dBuV/m)	Read Level (dBuV)	Limit (dBuV/m)	Margin (dB)	Antenna Factor (dB/m)	Cable Loss (dB)	Preamp Factor (dB)	Antenna Height (cm)	Table Angle (Degree)	Remark
32.91	36.47	54.49	40	-3.53	12.47	0.6	31.09	103	95	Peak
121.18	37.73	57.38	43.5	-5.77	11.09	1.16	31.9	104	72	Peak
222.06	18.16	38.22	46	-27.84	10.3	1.38	31.74	126	269	Peak
375.32	17.72	33.07	46	-28.28	14.75	1.84	31.94	105	9	Peak
481.05	20.51	33.35	46	-25.49	16.95	2.05	31.84	104	116	Peak
634.31	23.14	32.92	46	-22.86	20.02	2.32	32.12	113	92	Peak

Remarks:

- Emission Level = Read Level + Antenna Factor + Cable Loss - Preamp Factor  
Margin value = Emission level – Limit value

802.11ac (VHT80)

EUT Test Condition		Measurement Detail	
Channel	Channel 106	Frequency Range	30 MHz ~ 1 GHz
Input Power	120 Vac, 60 Hz	Detector Function	Peak (PK) Quasi-peak (QP)
Environmental Conditions	25 deg. C, 65 % RH	Tested By	Toby Tian

Antenna Polarity & Test Distance: Horizontal at 3 m										
Frequency (MHz)	Emission Level (dBuV/m)	Read Level (dBuV)	Limit (dBuV/m)	Margin (dB)	Antenna Factor (dB/m)	Cable Loss (dB)	Preamp Factor (dB)	Antenna Height (cm)	Table Angle (Degree)	Remark
33.88	27.72	45.57	40	-12.28	12.63	0.6	31.08	124	57	Peak
126.03	40.13	59.46	43.5	-3.37	11.42	1.14	31.89	127	252	Peak
182.29	23.98	43.97	43.5	-19.52	10.6	1.22	31.81	122	38	Peak
349.13	16.92	32.88	46	-29.08	14.12	1.76	31.84	102	337	Peak
507.24	20.9	32.91	46	-25.1	17.48	2.11	31.6	131	320	Peak
606.18	22.32	32.52	46	-23.68	19.68	2.27	32.15	135	311	Peak

Antenna Polarity & Test Distance: Vertical at 3 m										
Frequency (MHz)	Emission Level (dBuV/m)	Read Level (dBuV)	Limit (dBuV/m)	Margin (dB)	Antenna Factor (dB/m)	Cable Loss (dB)	Preamp Factor (dB)	Antenna Height (cm)	Table Angle (Degree)	Remark
33.88	37.01	54.86	40	-2.99	12.63	0.6	31.08	102	252	Peak
122.15	37.74	57.34	43.5	-5.76	11.15	1.15	31.9	136	304	Peak
224	18.25	38.25	46	-27.75	10.38	1.39	31.77	116	203	Peak
391.81	18.09	33.12	46	-27.91	15.14	1.89	32.06	115	87	Peak
494.63	20.17	32.58	46	-25.83	17.21	2.08	31.7	107	147	Peak
590.66	23.32	33.84	46	-22.68	19.39	2.24	32.15	123	126	Peak

Remarks:

- Emission Level = Read Level + Antenna Factor + Cable Loss - Preamp Factor  
Margin value = Emission level – Limit value

802.11a

EUT Test Condition		Measurement Detail	
Channel	Channel 165	Frequency Range	30 MHz ~ 1 GHz
Input Power	120 Vac, 60 Hz	Detector Function	Peak (PK) Quasi-peak (QP)
Environmental Conditions	25 deg. C, 65 % RH	Tested By	Toby Tian

Antenna Polarity & Test Distance: Horizontal at 3 m										
Frequency (MHz)	Emission Level (dBuV/m)	Read Level (dBuV)	Limit (dBuV/m)	Margin (dB)	Antenna Factor (dB/m)	Cable Loss (dB)	Preamp Factor (dB)	Antenna Height (cm)	Table Angle (Degree)	Remark
33.88	26.23	44.08	40	-13.77	12.63	0.6	31.08	114	247	Peak
126.03	39.51	58.84	43.5	-3.99	11.42	1.14	31.89	106	306	Peak
183.26	23.32	43.35	43.5	-20.18	10.53	1.23	31.79	133	91	Peak
332.64	17.16	33.52	46	-28.84	13.73	1.72	31.81	107	109	Peak
479.11	20.38	33.27	46	-25.62	16.91	2.05	31.85	121	82	Peak
579.99	22.28	33.03	46	-23.72	19.15	2.22	32.12	113	300	Peak

Antenna Polarity & Test Distance: Vertical at 3 m										
Frequency (MHz)	Emission Level (dBuV/m)	Read Level (dBuV)	Limit (dBuV/m)	Margin (dB)	Antenna Factor (dB/m)	Cable Loss (dB)	Preamp Factor (dB)	Antenna Height (cm)	Table Angle (Degree)	Remark
32.91	37.3	55.32	40	-2.7	12.47	0.6	31.09	124	75	Peak
120.21	37.21	56.93	43.5	-6.29	11.02	1.16	31.9	102	287	Peak
221.09	19.06	39.14	46	-26.94	10.26	1.38	31.72	120	242	Peak
360.77	17.72	33.49	46	-28.28	14.4	1.8	31.97	103	339	Peak
433.52	19.92	33.97	46	-26.08	16	1.96	32.01	136	48	Peak
578.05	22.67	33.46	46	-23.33	19.1	2.22	32.11	138	41	Peak

Remarks:

- Emission Level = Read Level + Antenna Factor + Cable Loss - Preamp Factor  
Margin value = Emission level – Limit value



## 4.2 Conducted Emission Measurement

### 4.2.1 Limits of Conducted Emission Measurement

Frequency (MHz)	Conducted Limit (dBuV)	
	Quasi-peak	Average
0.15 - 0.5	66 - 56	56 - 46
0.50 - 5.0	56	46
5.0 - 30.0	60	50

Note: 1. The lower limit shall apply at the transition frequencies.

2. The limit decreases in line with the logarithm of the frequency in the range of 0.15 to 0.50 MHz.

### 4.2.2 Test Instruments

Description & Manufacturer	Model No.	Serial No.	Date Of Calibration	Due Date Of Calibration
Test Receiver ROHDE & SCHWARZ	ESCI	100613	Nov. 16, 2015	Nov. 15, 2016
RF signal cable (with 10dB PAD) Woken	5D-FB	Cable-cond1-01	Dec. 26, 2015	Dec. 25, 2016
LISN ROHDE & SCHWARZ (EUT)	ESH3-Z5	835239/001	Feb. 26, 2016	Feb. 25, 2017
LISN ROHDE & SCHWARZ (Peripheral)	ESH3-Z5	100311	Jul. 24, 2015	Jul. 23, 2016
Software ADT	BV ADT_Cond_ V7.3.7.3	NA	NA	NA

**Note:** 1. The calibration interval of the above test instruments is 12 months and the calibrations are traceable to NML/ROC and NIST/USA.

2. The test was performed in HwaYa Shielded Room 1.

3. The VCCI Site Registration No. is C-2040.

#### 4.2.3 Test Procedures

- a. The EUT was placed 0.4 meters from the conducting wall of the shielded room with EUT being connected to the power mains through a line impedance stabilization network (LISN). Other support units were connected to the power mains through another LISN. The two LISNs provide 50 ohm/ 50uH of coupling impedance for the measuring instrument.
- b. Both lines of the power mains connected to the EUT were checked for maximum conducted interference.
- c. The frequency range from 150 kHz to 30 MHz was searched. Emission levels under (Limit -20 dB) was not recorded.

**NOTE:** All modes of operation were investigated and the worst-case emissions are reported.

#### 4.2.4 Deviation from Test Standard

No deviation.

#### 4.2.5 Test Setup

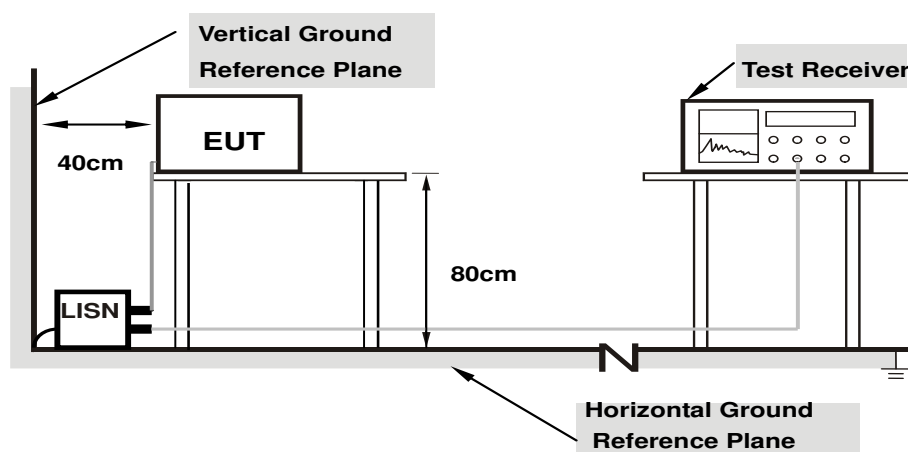

- Note: 1.Support units were connected to second LISN.**  
**2.Both of LISNs (AMN) are 80 cm from EUT and at least 80 from other units and other metal planes**

For the actual test configuration, please refer to the attached file (Test Setup Photo).

#### 4.2.6 EUT Operating Conditions

- a. Placed the EUT on a testing table.
- b. Use the software to control the EUT under transmission condition continuously at specific channel frequency.

#### 4.2.7 Test Results

##### Mode A

Phase	Line (L)	Detector Function	Quasi-Peak (QP) / Average (AV)
-------	----------	-------------------	--------------------------------

No	Freq. [MHz]	Corr.	Reading Value		Emission Level		Limit		Margin	
		Factor (dB)	[dB (uV)]		[dB (uV)]		[dB (uV)]		(dB)	
			Q.P.	AV.	Q.P.	AV.	Q.P.	AV.	Q.P.	AV.
1	0.15400	10.02	34.44	13.95	44.46	23.97	65.78	55.78	-21.33	-31.82
2	0.18600	10.03	29.62	8.47	39.65	18.50	64.21	54.21	-24.57	-35.72
3	0.21015	10.03	27.81	14.69	37.84	24.72	63.20	53.20	-25.35	-28.47
4	0.42200	10.12	23.76	12.27	33.88	22.39	57.41	47.41	-23.53	-25.02
<b>5</b>	<b>2.50600</b>	<b>10.31</b>	<b>21.74</b>	<b>20.26</b>	<b>32.05</b>	<b>30.57</b>	<b>56.00</b>	<b>46.00</b>	<b>-23.95</b>	<b>-15.43</b>
6	4.73000	10.45	17.19	9.60	27.64	20.05	56.00	46.00	-28.36	-25.95

#### REMARKS:

1. Q.P. and AV. are abbreviations of quasi-peak and average individually.
2. The emission levels of other frequencies were very low against the limit.
3. Margin value = Emission level - Limit value
4. Correction factor = Insertion loss + Cable loss
5. Emission Level = Correction Factor + Reading Value.

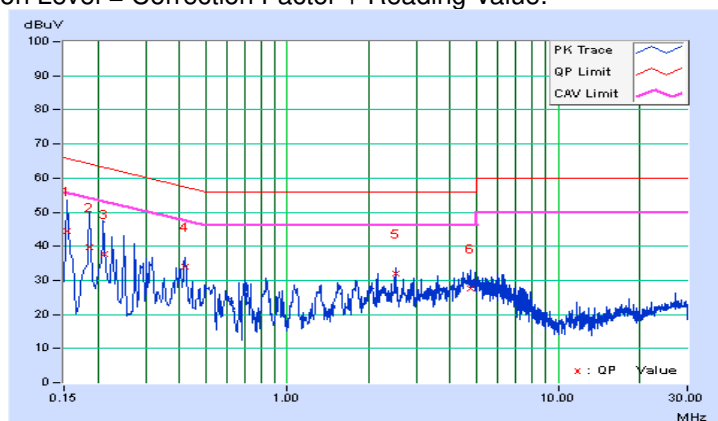

Phase	Neutral (N)	Detector Function	Quasi-Peak (QP) / Average (AV)
-------	-------------	-------------------	--------------------------------

No	Freq. [MHz]	Corr.	Reading Value		Emission Level		Limit		Margin	
		Factor	[dB (uV)]		[dB (uV)]		[dB (uV)]		(dB)	
	(dB)	Q.P.	AV.	Q.P.	AV.	Q.P.	AV.	Q.P.	AV.	
1	0.15400	10.03	32.48	13.74	42.51	23.77	65.78	55.78	-23.28	-32.02
2	0.17801	10.03	30.78	8.34	40.81	18.37	64.58	54.58	-23.76	-36.20
3	0.27278	10.07	20.58	1.62	30.65	11.69	61.03	51.03	-30.38	-39.34
4	0.41470	10.13	19.75	7.79	29.88	17.92	57.55	47.55	-27.67	-29.63
5	2.50600	10.32	21.37	17.40	31.69	27.72	56.00	46.00	-24.31	-18.28
6	4.87000	10.48	14.64	5.95	25.12	16.43	56.00	46.00	-30.88	-29.57

**REMARKS:**

1. Q.P. and AV. are abbreviations of quasi-peak and average individually.
2. The emission levels of other frequencies were very low against the limit.
3. Margin value = Emission level - Limit value
4. Correction factor = Insertion loss + Cable loss
5. Emission Level = Correction Factor + Reading Value.

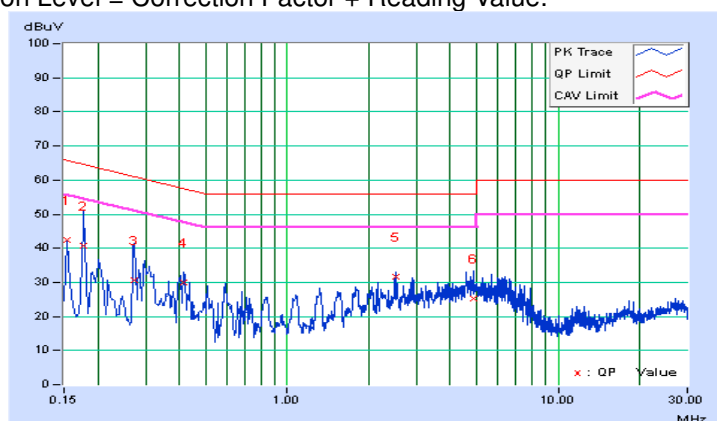

### Mode C

Phase	Line (L)	Detector Function	Quasi-Peak (QP) / Average (AV)
-------	----------	-------------------	--------------------------------

No	Freq. [MHz]	Corr. Factor	Reading Value [dB (uV)]		Emission Level [dB (uV)]		Limit [dB (uV)]		Margin (dB)	
		(dB)	Q.P.	AV.	Q.P.	AV.	Q.P.	AV.	Q.P.	AV.
	1	0.16600	10.02	32.81	11.62	42.83	21.64	65.16	55.16	-22.33
2	0.21400	10.04	27.30	13.09	37.34	23.13	63.05	53.05	-25.71	-29.92
3	0.29400	10.07	23.20	8.43	33.27	18.50	60.41	50.41	-27.14	-31.91
4	0.41361	10.12	22.46	10.09	32.58	20.21	57.58	47.58	-24.99	-27.36
<b>5</b>	<b>2.50200</b>	<b>10.31</b>	<b>22.05</b>	<b>20.47</b>	<b>32.36</b>	<b>30.78</b>	<b>56.00</b>	<b>46.00</b>	<b>-23.64</b>	<b>-15.22</b>
6	4.73400	10.45	17.59	8.86	28.04	19.31	56.00	46.00	-27.96	-26.69

### REMARKS:

1. Q.P. and AV. are abbreviations of quasi-peak and average individually.
2. The emission levels of other frequencies were very low against the limit.
3. Margin value = Emission level - Limit value
4. Correction factor = Insertion loss + Cable loss
5. Emission Level = Correction Factor + Reading Value.

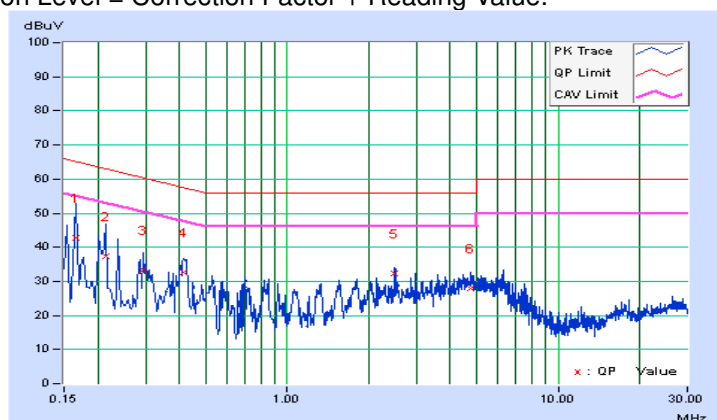

Phase	Neutral (N)	Detector Function	Quasi-Peak (QP) / Average (AV)
-------	-------------	-------------------	--------------------------------

No	Freq. [MHz]	Corr.	Reading Value		Emission Level		Limit		Margin	
		Factor	[dB (uV)]		[dB (uV)]		[dB (uV)]		(dB)	
		(dB)	Q.P.	AV.	Q.P.	AV.	Q.P.	AV.	Q.P.	AV.
1	0.16977	10.03	32.28	10.14	42.31	20.17	64.97	54.97	-22.66	-34.80
2	0.22200	10.05	26.14	7.05	36.19	17.10	62.74	52.74	-26.55	-35.64
3	0.29800	10.08	21.74	7.44	31.82	17.52	60.30	50.30	-28.47	-32.77
4	0.41361	10.13	20.66	8.55	30.79	18.68	57.58	47.58	-26.78	-28.89
5	2.50200	10.32	21.72	17.67	32.04	27.99	56.00	46.00	-23.96	-18.01
6	4.73400	10.48	16.81	7.48	27.29	17.96	56.00	46.00	-28.71	-28.04

**REMARKS:**

1. Q.P. and AV. are abbreviations of quasi-peak and average individually.
2. The emission levels of other frequencies were very low against the limit.
3. Margin value = Emission level - Limit value
4. Correction factor = Insertion loss + Cable loss
5. Emission Level = Correction Factor + Reading Value.

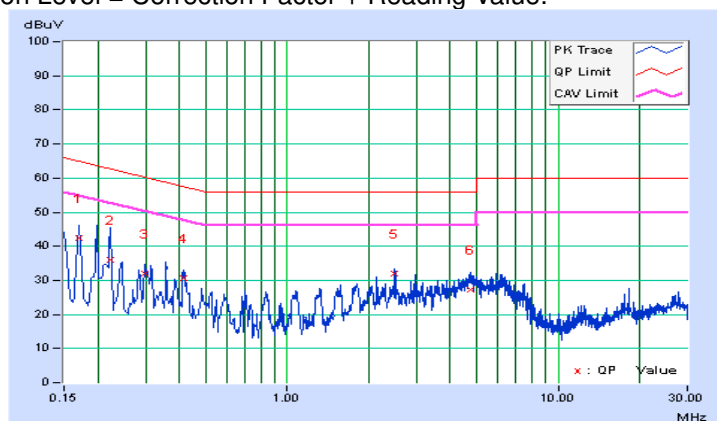

## 5 Pictures of Test Arrangements

Please refer to the attached file (Test Setup Photo).

## Appendix – Information on the Testing Laboratories

We, Bureau Veritas Consumer Products Services (H.K.) Ltd., Taoyuan Branch, were founded in 1988 to provide our best service in EMC, Radio, Telecom and Safety consultation. Our laboratories are accredited and approved according to ISO/IEC 17025.

If you have any comments, please feel free to contact us at the following:

### **Linko EMC/RF Lab**

Tel: 886-2-26052180

Fax: 886-2-26051924

### **Hsin Chu EMC/RF/Telecom Lab**

Tel: 886-3-6668565

Fax: 886-3-6668323

### **Hwa Ya EMC/RF/Safety**

Tel: 886-3-3183232

Fax: 886-3-3270892

**Email:** [service.adt@tw.bureauveritas.com](mailto:service.adt@tw.bureauveritas.com)

**Web Site:** [www.bureauveritas-adt.com](http://www.bureauveritas-adt.com)

The address and road map of all our labs can be found in our web site also.

--- END ---