

Partial FCC Test Report

Report No.: RF151109C30-3

FCC ID: VPYLB1EN

Test Model: LBEE5ZZ1EN

Received Date: Nov. 09, 2015

Test Date: Nov. 18, 2015 ~ Nov. 21, 2015

Issued Date: Dec. 07, 2015

Applicant: Murata Manufacturing Co., Ltd.

Address: 10-1, Higashikotari 1-chome, Nagaokakyo-shi, Kyoto 617-8555, Japan

Issued By: Bureau Veritas Consumer Products Services (H.K.) Ltd., Taoyuan Branch

Lab Address: No. 47-2, 14th Ling, Chia Pau Vil., Lin Kou Dist., New Taipei City, Taiwan (R.O.C)

Test Location (1): No. 19, Hwa Ya 2nd Rd, Wen Hwa Tsuen, Kwei Shan Hsiang, Taoyuan Hsien 333, Taiwan, R.O.C.



This report is for your exclusive use. Any copying or replication of this report to or for any other person or entity, or use of our name or trademark, is permitted only with our prior written permission. This report sets forth our findings solely with respect to the test samples identified herein. The results set forth in this report are not indicative or representative of the quality or characteristics of the lot from which a test sample was taken or any similar or identical product unless specifically and expressly noted. Our report includes all of the tests requested by you and the results thereof based upon the information that you provided to us. You have 60 days from date of issuance of this report to notify us of any material error or omission caused by our negligence, provided, however, that such notice shall be in writing and shall specifically address the issue you wish to raise. A failure to raise such issue within the prescribed time shall constitute your unqualified acceptance of the completeness of this report, the tests conducted and the correctness of the report contents. Unless specific mention, the uncertainty of measurement has been explicitly taken into account to declare the compliance or non-compliance to the specification. The report must not be used by the client to claim product certification, approval, or endorsement by TAF or any government agencies.

Table of Contents

Release Control Record	3
1 Certificate of Conformity	4
2 Summary of Test Results	5
2.1 Measurement Uncertainty.....	5
2.2 Modification Record	5
3 General Information	6
3.1 General Description of EUT.....	6
3.2 Description of Test Modes.....	8
3.2.1 Test Mode Applicability and Tested Channel Detail.....	10
3.3 Description of Support Units	12
3.3.1 Configuration of System under Test	12
3.4 General Description of Applied Standards.....	12
4 Test Types and Results	13
4.1 Radiated Emission and Bandedge Measurement	13
4.1.1 Limits of Radiated Emission and Bandedge Measurement	13
4.1.2 Limits of Unwanted Emission Out of the Restricted Bands.....	13
4.1.3 Test Instruments	14
4.1.4 Test Procedures.....	15
4.1.5 Deviation from Test Standard	15
4.1.6 Test Set Up	16
4.1.7 EUT Operating Conditions.....	16
4.1.8 Test Results	17
4.2 Conducted Emission Measurement.....	89
4.2.1 Limits of Conducted Emission Measurement	89
4.2.2 Test Instruments	89
4.2.3 Test Procedures.....	90
4.2.4 Deviation from Test Standard	90
4.2.5 Test Setup.....	90
4.2.6 EUT Operating Conditions.....	90
4.2.7 Test Results	91
5 Pictures of Test Arrangements	93
Appendix – Information on the Testing Laboratories	94



A D T

Release Control Record

Issue No.	Description	Date Issued
RF151109C30-3	Original Release	Dec. 07, 2015

2 Summary of Test Results

47 CFR FCC Part 15, Subpart E (Section 15.407)			
FCC Clause	Test Item	Result	Remarks
15.407(b)(6)	AC Power Conducted Emissions	Pass	Meet the requirement of limit. Minimum passing margin is -19.57 dB at 0.16569 MHz.
15.407(b)(1/2/3/4/6)	Radiated Emissions & Band Edge Measurement	Pass	Meet the requirement of limit. Minimum passing margin is -1.85 dB at 5725 MHz.
15.407(a)(1/2/3)	Max Average Transmit Power	N/A	Refer to Note ad below.
15.407(a)(1/2/3)	Peak Power Spectral Density	N/A	Refer to Note ad below.
15.407(e)	6 dB Bandwidth	N/A	Refer to Note ad below.
15.407(g)	Frequency Stability	N/A	Refer to Note ad below.
15.203	Antenna Requirement	N/A	Refer to Note ad below.

Note: Only test items for AC Power Conducted Emission and Radiated Emissions & Band Edge Measurement were performed for this report. Refer to module (Model: LBEE5ZZ1EN, FCC ID: VPYLB1EN) Report No.: 10689818H-C-R1 for other testing data.

2.1 Measurement Uncertainty

Where relevant, the following measurement uncertainty levels have been estimated for tests performed on the EUT as specified in CISPR 16-4-2:

Measurement	Frequency	Expanded Uncertainty (k=2) (±)
Conducted Emissions at mains ports	150 kHz ~ 30 MHz	2.44 dB
Radiated Emissions up to 1 GHz	30 MHz ~ 200 MHz	2.93 dB
	200 MHz ~ 1000 MHz	2.95 dB
Radiated Emissions above 1 GHz	1 GHz ~ 18 GHz	2.26 dB
	18 GHz ~ 40 GHz	1.94 dB

2.2 Modification Record

There were no modifications required for compliance.

3 General Information

3.1 General Description of EUT

Product	Communication Module	
Brand	Murata	
Test Model	LBEE5ZZ1EN	
Power Supply Rating	19.5 Vdc (adapter)	
Modulation Type	256QAM, 64QAM, 16QAM, QPSK, BPSK	
Modulation Technology	OFDM	
Transfer Rate	802.11a: 54.0/ 48.0/ 36.0/ 24.0/ 18.0/ 12.0/ 9.0/ 6.0 Mbps 802.11n: up to MCS7 802.11ac: up to V9	
Operating Frequency	5180 ~ 5240 MHz, 5260 ~ 5320 MHz, 5500 ~ 5700 MHz, 5745 ~ 5825 MHz	
Number of Channel	5180 ~ 5240 MHz: 4 for 802.11a, 802.11n (HT20) 2 for 802.11n (HT40) 1 for 802.11ac (VHT80) 5260 ~ 5320 MHz: 4 for 802.11a, 802.11n (HT20) 2 for 802.11n (HT40) 1 for 802.11ac (VHT80) 5500 ~ 5700 MHz: 8 for 802.11a, 802.11n (HT20) 3 for 802.11n (HT40) 2 for 802.11ac (VHT80) 5745 ~ 5825 MHz: 5 for 802.11a, 802.11n (HT20) 2 for 802.11n (HT40) 1 for 802.11ac (VHT80)	
Antenna Type	Antenna 1 (Monopole Antenna)	3.61 dBi gain (5180 ~ 5240 MHz) 3.61 dBi gain (5260 ~ 5320 MHz) 3.61 dBi gain (5500 ~ 5700 MHz) 3.61 dBi gain (5745 ~ 5825 MHz)
	Antenna 2 (Dipole Antenna)	5 dBi gain (5180 ~ 5240 MHz) 5 dBi gain (5260 ~ 5320 MHz) 5 dBi gain (5500 ~ 5700 MHz) 5 dBi gain (5745 ~ 5825 MHz)
Antenna Connector	N/A	
Accessory Device	Refer to Note as below	
Data Cable Supplied	Refer to Note as below	

Note:

1. The EUT incorporates a MIMO function. Physically, the EUT provides two completed transmitters and two receivers.

Modulation Mode	Tx Function
802.11b	1TX
802.11g	1TX
802.11a	1TX
802.11n (HT20)	2TX
802.11n (HT40)	2TX
802.11ac (VHT80)	2TX

* The modulation and bandwidth are similar for 802.11n mode for HT20 / HT40 and 802.11ac mode for HT20 / HT40, therefore investigated worst case to representative mode in test report. (Final test mode refer section 3.2.1)

2. The EUT contains following accessory devices.

Product	Brand	Model	Description
Adapter	DELL	HK65NM130	I/P: 100-240Vac, 50-60Hz, 1.7A O/P: 19.5Vdc, 3.34A
Platform	DELL	N01G	--
Antenna 1 (Monopole Antenna)	taoglas	MA761.B.B1CG.014	Pantheon Antenna 4in1 MA761
Antenna 2 (Dipole Antenna)	Laird	PVD24515-DE1	PCB Dipole Antenna

3. Since the module report was also verified with dipole antenna and the antenna gain was the same as antenna 2 (Brand: Laird). Therefore, only the test data for monopole antenna was presented in the report.
4. The above EUT information is declared by manufacturer and for more detailed features description, please refer to the manufacturer's specifications or user's manual.

3.2 Description of Test Modes

FOR 5180 ~ 5240 MHz

4 channels are provided for 802.11a, 802.11n (HT20):

Channel	Frequency (MHz)	Channel	Frequency (MHz)
36	5180	44	5220
40	5200	48	5240

2 channels are provided for 802.11n (HT40):

Channel	Frequency (MHz)	Channel	Frequency (MHz)
38	5190	46	5230

1 channel is provided for 802.11ac (VHT80):

Channel	Frequency (MHz)
42	5210

FOR 5260 ~ 5320 MHz

4 channels are provided for 802.11a, 802.11n (HT20):

Channel	Frequency (MHz)	Channel	Frequency (MHz)
52	5260	60	5300
56	5280	64	5320

2 channels are provided for 802.11n (HT40):

Channel	Frequency (MHz)	Channel	Frequency (MHz)
54	5270	62	5310

1 channel is provided for 802.11ac (VHT80):

Channel	Frequency (MHz)
58	5290

FOR 5500 ~ 5700 MHz

11 channels are provided for 802.11a, 802.11n (HT20):

Channel	Frequency (MHz)	Channel	Frequency (MHz)
100	5500	124	5620
104	5520	128	5640
108	5540	132	5660
112	5560	136	5680
116	5580	140	5700
120	5600		

5 channels are provided for 802.11n (HT40):

Channel	Frequency (MHz)	Channel	Frequency (MHz)
102	5510	126	5630
110	5550	134	5670
118	5590		

2 channels are provided for 802.11ac (VHT80):

Channel	Frequency (MHz)	Channel	Frequency (MHz)
106	5530	122	5610

FOR 5745 ~ 5825 MHz:

5 channels are provided for 802.11a, 802.11n (HT20):

Channel	Frequency (MHz)	Channel	Frequency (MHz)
149	5745	161	5805
153	5765	165	5825
157	5785		

2 channels are provided for 802.11n (HT40):

Channel	Frequency (MHz)	Channel	Frequency (MHz)
151	5755	159	5795

1 channel is provided for 802.11ac (VHT80):

Channel	Frequency (MHz)
155	5775

3.2.1 Test Mode Applicability and Tested Channel Detail

EUT Configure Mode	Applicable To			Description
	RE \geq 1G	RE $<$ 1G	PLC	
A	√	√	√	1 Tx
B	√	√	-	2 Tx

Where **RE \geq 1G**: Radiated Emission above 1 GHz **RE $<$ 1G**: Radiated Emission below 1 GHz
PLC: Power Line Conducted Emission

NOTE:

1. The EUT had been pre-tested on the positioned of each 3 axis. The worst case was found when positioned on **Z-plane**.
2. "-" means no effect.

Radiated Emission Test (Above 1 GHz):

- Pre-Scan has been conducted to determine the worst-case mode from all possible combinations between available modulations, data rates and antenna ports (if EUT with antenna diversity architecture).
- Following channel(s) was (were) selected for the final test as listed below.

EUT Configure Mode	Mode	Frequency Band (MHz)	Available Channel	Tested Channel	Modulation Technology	Modulation Type	Data Rate (Mbps)
A	802.11a	5180-5240	36 to 48	36, 40, 48	OFDM	BPSK	6.0
	802.11n (HT20)		36 to 48	36, 40, 48	OFDM	BPSK	MCS0
	802.11n (HT40)		38 to 46	38, 46	OFDM	BPSK	MCS0
	802.11ac (VHT80)		42	42	OFDM	BPSK	V0
	802.11a	5260-5320	52 to 64	52, 60, 64	OFDM	BPSK	6.0
	802.11n (HT20)		52 to 64	52, 60, 64	OFDM	BPSK	MCS0
	802.11n (HT40)		54 to 62	54, 62	OFDM	BPSK	MCS0
	802.11ac (VHT80)		58	58	OFDM	BPSK	V0
	802.11a	5500-5700	100 to 140	100, 116, 140	OFDM	BPSK	6.0
	802.11n (HT20)		100 to 140	100, 116, 140	OFDM	BPSK	MCS0
	802.11n (HT40)		102 to 134	102, 110, 134	OFDM	BPSK	MCS0
	802.11ac (VHT80)		106 to 122	106, 122	OFDM	BPSK	V0
	802.11a	5745-5825	149 to 165	149, 157, 165	OFDM	BPSK	6.0
	802.11n (HT20)		149 to 165	149, 157, 165	OFDM	BPSK	MCS0
	802.11n (HT40)		151 to 159	151, 159	OFDM	BPSK	MCS0
	802.11ac (VHT80)		155	155	OFDM	BPSK	V0
B	802.11n (HT20)	5180-5240	36 to 48	36, 40, 48	OFDM	BPSK	MCS0
	802.11n (HT40)		38 to 46	38, 46	OFDM	BPSK	MCS0
	802.11ac (VHT80)		42	42	OFDM	BPSK	V0
	802.11n (HT20)	5260-5320	52 to 64	52, 60, 64	OFDM	BPSK	MCS0
	802.11n (HT40)		54 to 62	54, 62	OFDM	BPSK	MCS0
	802.11ac (VHT80)		58	58	OFDM	BPSK	V0
	802.11n (HT20)	5500-5700	100 to 140	100, 116, 140	OFDM	BPSK	MCS0
	802.11n (HT40)		102 to 134	102, 110, 134	OFDM	BPSK	MCS0
	802.11ac (VHT80)		106 to 122	106, 122	OFDM	BPSK	V0
	802.11n (HT20)	5745-5825	149 to 165	149, 157, 165	OFDM	BPSK	MCS0
	802.11n (HT40)		151 to 159	151, 159	OFDM	BPSK	MCS0
	802.11ac (VHT80)		155	155	OFDM	BPSK	V0

Radiated Emission Test (Below 1 GHz):

- Pre-Scan has been conducted to determine the worst-case mode from all possible combinations between available modulations, data rates and antenna ports (if EUT with antenna diversity architecture).
- Following channel(s) was (were) selected for the final test as listed below.

EUT Configure Mode	Mode	Frequency Band (MHz)	Available Channel	Tested Channel	Modulation Technology	Modulation Type	Data Rate (Mbps)
A	802.11n (HT40)	5180-5240	38 to 46	38	OFDM	BPSK	MCS0
	802.11n (HT40)	5260-5320	54 to 62	62	OFDM	BPSK	MCS0
	802.11n (HT20)	5500-5700	100 to 140	140	OFDM	BPSK	MCS0
	802.11a	5745-5825	149 to 165	165	OFDM	BPSK	6.0
B	802.11n (HT40)	5180-5240	38 to 46	38	OFDM	BPSK	MCS0
	802.11n (HT40)	5260-5320	54 to 62	62	OFDM	BPSK	MCS0
	802.11n (HT40)	5500-5700	102 to 134	102	OFDM	BPSK	MCS0
	802.11n (HT40)	5745-5825	151 to 159	151	OFDM	BPSK	MCS0

Power Line Conducted Emission Test:

- Pre-Scan has been conducted to determine the worst-case mode from all possible combinations between available modulations, data rates and antenna ports (if EUT with antenna diversity architecture).
- Following channel(s) was (were) selected for the final test as listed below.

EUT Configure Mode	Mode	Frequency Band (MHz)	Available Channel	Tested Channel	Modulation Technology	Modulation Type	Data Rate (Mbps)
A	802.11n (HT20)	5500-5700	100 to 140	140	OFDM	BPSK	MCS0

Test Condition:

Applicable To	Environmental Conditions	Input Power	Tested by
RE≥1G	25 deg. C, 65 % RH	120 Vac, 60 Hz	Gavin Wu
RE<1G	25 deg. C, 65 % RH	120 Vac, 60 Hz	Gavin Wu
PLC	25 deg. C, 65 % RH	120 Vac, 60 Hz	Toby Tian

3.3 Description of Support Units

The EUT has been tested as an independent unit together with other necessary accessories or support units.

3.3.1 Configuration of System under Test

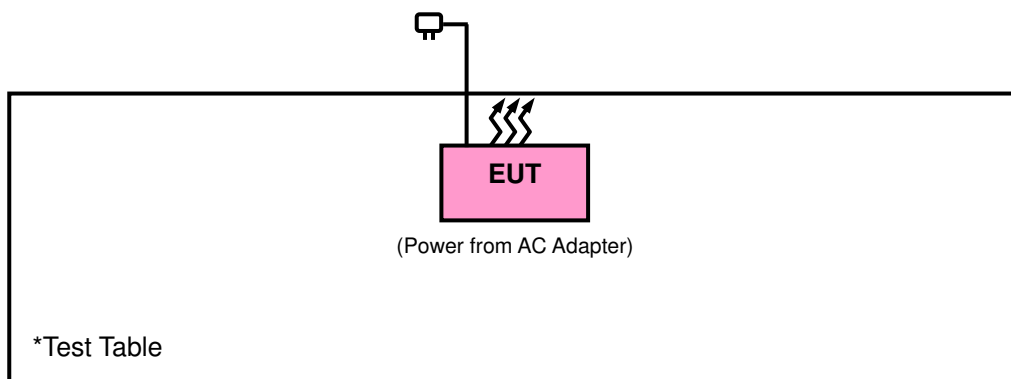

3.4 General Description of Applied Standards

The EUT is a RF Product. According to the specifications of the manufacturer, it must comply with the requirements of the following standards:

FCC Part 15, Subpart E (15.407)

789033 D02 General UNII Test Procedures New Rules v01

644545 D01 Guidance for IEEE 802 11ac v01r02

662911 D01 Multiple Transmitter Output v02r01

ANSI C63.10-2013

All test items have been performed and recorded as per the above standards.

NOTE: The EUT has been verified to comply with the requirements of FCC Part 15, Subpart B, Class B (DoC).
The test report has been issued separately.

4 Test Types and Results

4.1 Radiated Emission and Bandedge Measurement

4.1.1 Limits of Radiated Emission and Bandedge Measurement

Radiated emissions which fall in the restricted bands must comply with the radiated emission limits specified as below table. Other emissions shall be at least 20 dB below the highest level of the desired power:

Frequencies (MHz)	Field Strength (microvolts/meter)	Measurement Distance (meters)
0.009 ~ 0.490	2400/F (kHz)	300
0.490 ~ 1.705	24000/F (kHz)	30
1.705 ~ 30.0	30	30
30 ~ 88	100	3
88 ~ 216	150	3
216 ~ 960	200	3
Above 960	500	3

NOTE:

1. The lower limit shall apply at the transition frequencies.
2. Emission level (dBuV/m) = 20 log Emission level (uV/m).
3. For frequencies above 1000 MHz, the field strength limits are based on average detector, however, the peak field strength of any emission shall not exceed the maximum permitted average limits, specified above by more than 20 dB under any condition of modulation.

4.1.2 Limits of Unwanted Emission Out of the Restricted Bands

Applicable To	Limit	
789033 D02 General UNII Test Procedures New Rules v01	Field Strength at 3 m	
	PK: 74 (dBμV/m)	AV: 54 (dBμV/m)
Applicable To	EIRP Limit	Equivalent Field Strength at 3 m
15.407(b)(1)	PK: -27 (dBm/MHz)	PK: 68.2 (dBμV/m)
15.407(b)(2)		
15.407(b)(3)		
15.407(b)(4)	PK: -27 (dBm/MHz) ^{*1} PK: -17 (dBm/MHz) ^{*2}	PK: 68.2 (dBμV/m) ^{*1} PK: 78.2 (dBμV/m) ^{*2}

NOTE: ^{*1} beyond 10 MHz of the band edge ^{*2} within 10 MHz of band edge

The following formula is used to convert the equipment isotropic radiated power (eirp) to field strength:

$$E = \frac{1000000\sqrt{30P}}{3} \mu\text{V/m, where } P \text{ is the eirp (Watts).}$$

4.1.3 Test Instruments

Description & Manufacturer	Model No.	Serial No.	Date of Calibration	Due Date of Calibration
Test Receiver Agilent	N9038A	MY51210203	Jan. 21, 2015	Jan. 21, 2016
Spectrum Analyzer Agilent	N9010A	MY52220314	Sep. 03, 2015	Sep. 02, 2016
BILOG Antenna SCHWARZBECK	VULB9168	9168-472	Feb. 04, 2015	Feb. 04, 2016
HORN Antenna SCHWARZBECK	BBHA 9120 D	9120D-969	Feb. 09, 2015	Feb. 09, 2016
HORN Antenna SCHWARZBECK	BBHA 9170	9170-480	Feb. 04, 2015	Feb. 04, 2016
Loop Antenna	EM-6879	269	Jul. 31, 2015	Jul. 30, 2016
Preamplifier EMCI	EMC 012645	980115	Dec. 12, 2014	Dec. 11, 2015
Preamplifier EMCI	EMC 184045	980116	Jan. 09, 2015	Jan. 08, 2016
Preamplifier EMCI	EMC 330H	980112	Dec. 27, 2014	Dec. 26, 2015
RF signal cable HUBER+SUHNNER	SUCOFLEX 104	309219/4 2950114	Oct. 12, 2015	Oct. 11, 2016
RF signal cable HUBER+SUHNNER	SUCOFLEX 104	250130/4	Oct. 12, 2015	Oct. 11, 2016
RF Coaxial Cable Worken	8D-FB	Cable-Ch10-01	Oct. 12, 2015	Oct. 11, 2016
Software BV ADT	E3 6.120103	NA	NA	NA
Antenna Tower MF	MFA-440H	NA	NA	NA
Turn Table MF	MFT-201SS	NA	NA	NA
Antenna Tower & Turn Table Controller MF	MF-7802	NA	NA	NA

- Note: 1. The calibration interval of the above test instruments is 12 months and the calibrations are traceable to NML/ROC and NIST/USA.
2. The test was performed in HwaYa Chamber 10.
3. The horn antenna and preamplifier (model: EMC 184045) are used only for the measurement of emission frequency above 1 GHz if tested.
4. The FCC Site Registration No. is 690701.
5. The IC Site Registration No. is IC7450F-10.

4.1.4 Test Procedures

- a. The EUT was placed on the top of a rotating table 0.8 meters (for below 1 GHz) / 1.5 meters (for above 1 GHz) above the ground at 3 meter chamber room for test. The table was rotated 360 degrees to determine the position of the highest radiation.
- b. The EUT was set 3 meters away from the interference-receiving antenna, which was mounted on the top of a variable-height antenna tower.
- c. The height of antenna is varied from one meter to four meters above the ground to determine the maximum value of the field strength. Both horizontal and vertical polarizations of the antenna are set to make the measurement.
- d. For each suspected emission, the EUT was arranged to its worst case and then the antenna was tuned to heights from 1 meter to 4 meters and the rotatable table was turned from 0 degrees to 360 degrees to find the maximum reading.
- e. The test-receiver system was set to quasi-peak detect function and specified bandwidth with maximum hold mode when the test frequency is below 1 GHz.
- f. The test-receiver system was set to peak and average detected function and specified bandwidth with maximum hold mode when the test frequency is above 1 GHz. If the peak reading value also meets average limit, measurement with the average detector is unnecessary.

Note:

1. The resolution bandwidth and video bandwidth of test receiver/spectrum analyzer is 120 kHz for Quasi-peak detection (QP) at frequency below 1 GHz.
2. The resolution bandwidth of test receiver/spectrum analyzer is 1 MHz and the video bandwidth is 3 MHz for Peak detection (PK) at frequency above 1 GHz.
3. The resolution bandwidth of test receiver/spectrum analyzer is 1 MHz and the video bandwidth is 3 MHz for RMS Average (Duty cycle < 98 %) for Average detection (AV) at frequency above 1 GHz, then the measurement results was added to a correction factor ($10 \log(1/\text{duty cycle})$).
4. The resolution bandwidth of test receiver/spectrum analyzer is 1 MHz and the video bandwidth is 10 Hz (Duty cycle ≥ 98 %) for Average detection (AV) at frequency above 1 GHz.
5. All modes of operation were investigated and the worst-case emissions are reported.

4.1.5 Deviation from Test Standard

No deviation.

4.1.6 Test Set Up

<Frequency Range below 1 GHz>

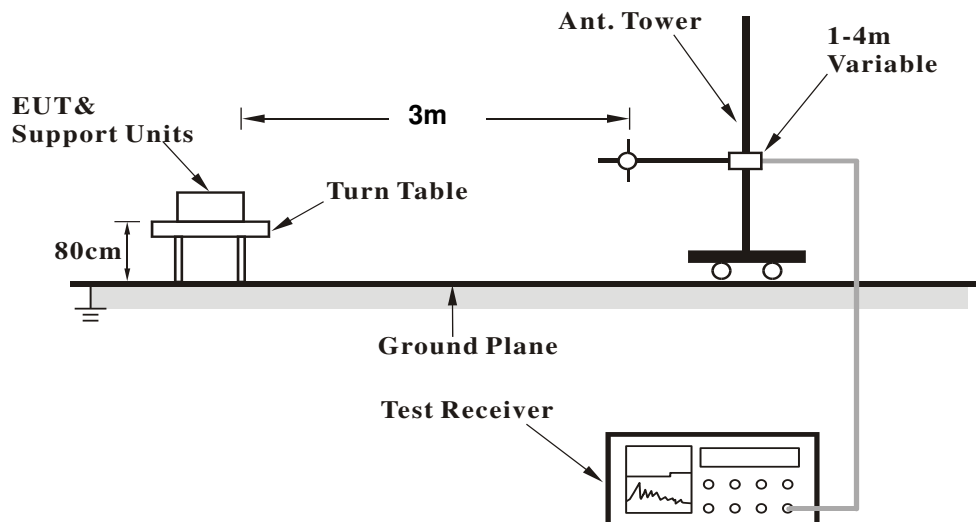

<Frequency Range above 1 GHz>

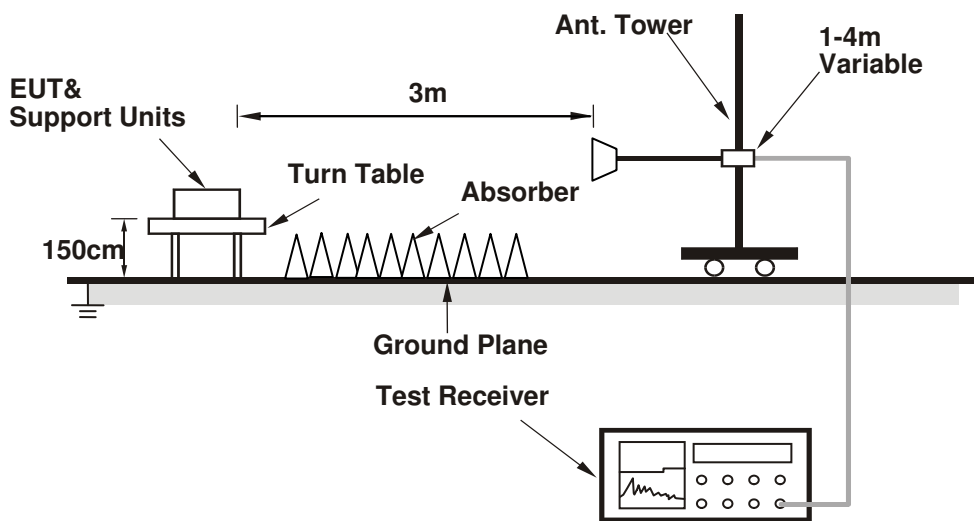

For the actual test configuration, please refer to the attached file (Test Setup Photo).

4.1.7 EUT Operating Conditions

- a. Placed the EUT on a testing table.
- b. Use the software to control the EUT under transmission condition continuously at specific channel frequency.

4.1.8 Test Results
Mode A
ABOVE 1 GHz DATA :
802.11a

EUT TEST CONDITION		MEASUREMENT DETAIL	
CHANNEL	Channel 36	FREQUENCY RANGE	1 GHz ~ 40 GHz
INPUT POWER	120 Vac, 60 Hz	DETECTOR FUNCTION	Peak (PK) Average (AV)
ENVIRONMENTAL CONDITIONS	25 deg. C, 65 % RH	TESTED BY	Gavin Wu

ANTENNA POLARITY & TEST DISTANCE: HORIZONTAL AT 3 M										
FREQ. (MHz)	EMISSION LEVEL (dBuV/m)	READ LEVEL (dBuV)	LIMIT (dBuV/m)	MARGIN (dB)	ANTENNA FACTOR (dB/m)	CABLE LOSS (dB)	PREAMP FACTOR (dB)	ANTENNA HEIGHT (cm)	TABLE ANGLE (Degree)	REMARK
5140	43	42.78	54	-11	31.32	6.2	37.3	120	151	Average
5140	61.04	60.82	74	-12.96	31.32	6.2	37.3	120	151	Peak
5180	90.76	90.53			31.35	6.22	37.34	120	151	Average
5180	101.19	100.96			31.35	6.22	37.34	120	151	Peak
5446	40.27	39.5	54	-13.73	31.56	6.34	37.13	120	151	Average
5446	60.79	60.02	74	-13.21	31.56	6.34	37.13	120	151	Peak
ANTENNA POLARITY & TEST DISTANCE: VERTICAL AT 3 M										
FREQ. (MHz)	EMISSION LEVEL (dBuV/m)	READ LEVEL (dBuV)	LIMIT (dBuV/m)	MARGIN (dB)	ANTENNA FACTOR (dB/m)	CABLE LOSS (dB)	PREAMP FACTOR (dB)	ANTENNA HEIGHT (cm)	TABLE ANGLE (Degree)	REMARK
5022	44.67	44.53	54	-9.33	31.23	6.15	37.24	187	148	Average
5022	60.26	60.12	74	-13.74	31.23	6.15	37.24	187	148	Peak
5180	96.07	95.84			31.35	6.22	37.34	187	148	Average
5180	105.35	105.12			31.35	6.22	37.34	187	148	Peak
5450	38.43	37.61	54	-15.57	31.56	6.34	37.08	187	148	Average
5450	59.57	58.75	74	-14.43	31.56	6.34	37.08	187	148	Peak

REMARKS:

- Emission Level = Read Level + Antenna Factor + Cable Loss - Preamp Factor
Margin value = Emission level – Limit value
- 5180 MHz: Fundamental frequency.



A D T

EUT TEST CONDITION		MEASUREMENT DETAIL	
CHANNEL	Channel 44	FREQUENCY RANGE	1 GHz ~ 40 GHz
INPUT POWER	120 Vac, 60 Hz	DETECTOR FUNCTION	Peak (PK) Average (AV)
ENVIRONMENTAL CONDITIONS	25 deg. C, 65 % RH	TESTED BY	Gavin Wu

ANTENNA POLARITY & TEST DISTANCE: HORIZONTAL AT 3 M										
FREQ. (MHz)	EMISSION LEVEL (dBuV/m)	READ LEVEL (dBuV)	LIMIT (dBuV/m)	MARGIN (dB)	ANTENNA FACTOR (dB/m)	CABLE LOSS (dB)	PREAMP FACTOR (dB)	ANTENNA HEIGHT (cm)	TABLE ANGLE (Degree)	REMARK
5050	38.1	37.96	54	-15.9	31.24	6.15	37.25	172	133	Average
5050	59.46	59.32	74	-14.54	31.24	6.15	37.25	172	133	Peak
5220	91.47	91.22			31.37	6.24	37.36	172	133	Average
5220	101.79	101.54			31.37	6.24	37.36	172	133	Peak
5402	38.2	37.54	54	-15.8	31.52	6.32	37.18	172	133	Average
5402	60.23	59.57	74	-13.77	31.52	6.32	37.18	172	133	Peak

ANTENNA POLARITY & TEST DISTANCE: VERTICAL AT 3 M										
FREQ. (MHz)	EMISSION LEVEL (dBuV/m)	READ LEVEL (dBuV)	LIMIT (dBuV/m)	MARGIN (dB)	ANTENNA FACTOR (dB/m)	CABLE LOSS (dB)	PREAMP FACTOR (dB)	ANTENNA HEIGHT (cm)	TABLE ANGLE (Degree)	REMARK
5020	38.81	38.69	54	-15.19	31.21	6.15	37.24	186	148	Average
5020	60.41	60.29	74	-13.59	31.21	6.15	37.24	186	148	Peak
5220	95.7	95.45			31.37	6.24	37.36	186	148	Average
5220	105.21	104.96			31.37	6.24	37.36	186	148	Peak
5388	38.38	37.74	54	-15.62	31.51	6.31	37.18	186	148	Average
5388	59.59	58.95	74	-14.41	31.51	6.31	37.18	186	148	Peak

REMARKS:

- Emission Level = Read Level + Antenna Factor + Cable Loss - Preamp Factor
Margin value = Emission level – Limit value
- 5220 MHz: Fundamental frequency.

EUT TEST CONDITION		MEASUREMENT DETAIL	
CHANNEL	Channel 48	FREQUENCY RANGE	1 GHz ~ 40 GHz
INPUT POWER	120 Vac, 60 Hz	DETECTOR FUNCTION	Peak (PK) Average (AV)
ENVIRONMENTAL CONDITIONS	25 deg. C, 65 % RH	TESTED BY	Gavin Wu

ANTENNA POLARITY & TEST DISTANCE: HORIZONTAL AT 3 M										
FREQ. (MHz)	EMISSION LEVEL (dBuV/m)	READ LEVEL (dBuV)	LIMIT (dBuV/m)	MARGIN (dB)	ANTENNA FACTOR (dB/m)	CABLE LOSS (dB)	PREAMP FACTOR (dB)	ANTENNA HEIGHT (cm)	TABLE ANGLE (Degree)	REMARK
5082	38.07	37.9	54	-15.93	31.27	6.17	37.27	133	222	Average
5082	60.34	60.17	74	-13.66	31.27	6.17	37.27	133	222	Peak
5240	91.31	90.99			31.39	6.25	37.32	133	222	Average
5240	101.69	101.37			31.39	6.25	37.32	133	222	Peak
5408	38.23	37.57	54	-15.77	31.52	6.32	37.18	133	222	Average
5408	60.06	59.4	74	-13.94	31.52	6.32	37.18	133	222	Peak
ANTENNA POLARITY & TEST DISTANCE: VERTICAL AT 3 M										
FREQ. (MHz)	EMISSION LEVEL (dBuV/m)	READ LEVEL (dBuV)	LIMIT (dBuV/m)	MARGIN (dB)	ANTENNA FACTOR (dB/m)	CABLE LOSS (dB)	PREAMP FACTOR (dB)	ANTENNA HEIGHT (cm)	TABLE ANGLE (Degree)	REMARK
5050	40.42	40.28	54	-13.58	31.24	6.15	37.25	187	154	Average
5050	59.01	58.87	74	-14.99	31.24	6.15	37.25	187	154	Peak
5240	98.08	97.76			31.39	6.25	37.32	187	154	Average
5240	106.78	106.46			31.39	6.25	37.32	187	154	Peak
5438	40.36	39.6	54	-13.64	31.55	6.34	37.13	187	154	Average
5438	60.09	59.33	74	-13.91	31.55	6.34	37.13	187	154	Peak

REMARKS:

- Emission Level = Read Level + Antenna Factor + Cable Loss - Preamp Factor
Margin value = Emission level – Limit value
- 5240 MHz: Fundamental frequency.



A D T

EUT TEST CONDITION		MEASUREMENT DETAIL	
CHANNEL	Channel 52	FREQUENCY RANGE	1 GHz ~ 40 GHz
INPUT POWER	120 Vac, 60 Hz	DETECTOR FUNCTION	Peak (PK) Average (AV)
ENVIRONMENTAL CONDITIONS	25 deg. C, 65 % RH	TESTED BY	Gavin Wu

ANTENNA POLARITY & TEST DISTANCE: HORIZONTAL AT 3 M										
FREQ. (MHz)	EMISSION LEVEL (dBuV/m)	READ LEVEL (dBuV)	LIMIT (dBuV/m)	MARGIN (dB)	ANTENNA FACTOR (dB/m)	CABLE LOSS (dB)	PREAMP FACTOR (dB)	ANTENNA HEIGHT (cm)	TABLE ANGLE (Degree)	REMARK
5062	38.27	38.1	54	-15.73	31.25	6.17	37.25	214	181	Average
5062	60.66	60.49	74	-13.34	31.25	6.17	37.25	214	181	Peak
5260	95.26	94.87			31.41	6.25	37.27	214	181	Average
5260	104.4	104.01			31.41	6.25	37.27	214	181	Peak
5350	38.3	37.71	54	-15.7	31.48	6.29	37.18	214	181	Average
5350	60.19	59.6	74	-13.81	31.48	6.29	37.18	214	181	Peak

ANTENNA POLARITY & TEST DISTANCE: VERTICAL AT 3 M										
FREQ. (MHz)	EMISSION LEVEL (dBuV/m)	READ LEVEL (dBuV)	LIMIT (dBuV/m)	MARGIN (dB)	ANTENNA FACTOR (dB/m)	CABLE LOSS (dB)	PREAMP FACTOR (dB)	ANTENNA HEIGHT (cm)	TABLE ANGLE (Degree)	REMARK
5108	38.4	38.2	54	-15.6	31.29	6.19	37.28	120	138	Average
5108	61.32	61.12	74	-12.68	31.29	6.19	37.28	120	138	Peak
5260	96.22	95.83			31.41	6.25	37.27	120	138	Average
5260	105.52	105.13			31.41	6.25	37.27	120	138	Peak
5432	38.44	37.7	54	-15.56	31.55	6.32	37.13	120	138	Average
5432	60.3	59.56	74	-13.7	31.55	6.32	37.13	120	138	Peak

REMARKS:

- Emission Level = Read Level + Antenna Factor + Cable Loss - Preamp Factor
Margin value = Emission level – Limit value
- 5260 MHz: Fundamental frequency.

EUT TEST CONDITION		MEASUREMENT DETAIL	
CHANNEL	Channel 60	FREQUENCY RANGE	1 GHz ~ 40 GHz
INPUT POWER	120 Vac, 60 Hz	DETECTOR FUNCTION	Peak (PK) Average (AV)
ENVIRONMENTAL CONDITIONS	25 deg. C, 65 % RH	TESTED BY	Gavin Wu

ANTENNA POLARITY & TEST DISTANCE: HORIZONTAL AT 3 M										
FREQ. (MHz)	EMISSION LEVEL (dBuV/m)	READ LEVEL (dBuV)	LIMIT (dBuV/m)	MARGIN (dB)	ANTENNA FACTOR (dB/m)	CABLE LOSS (dB)	PREAMP FACTOR (dB)	ANTENNA HEIGHT (cm)	TABLE ANGLE (Degree)	REMARK
5110	38.49	38.29	54	-15.51	31.29	6.19	37.28	203	174	Average
5110	60.52	60.32	74	-13.48	31.29	6.19	37.28	203	174	Peak
5300	95.41	94.89			31.44	6.27	37.19	203	174	Average
5300	104.56	104.04			31.44	6.27	37.19	203	174	Peak
5444	39.1	38.34	54	-14.9	31.55	6.34	37.13	203	174	Average
5444	59.97	59.21	74	-14.03	31.55	6.34	37.13	203	174	Peak
ANTENNA POLARITY & TEST DISTANCE: VERTICAL AT 3 M										
FREQ. (MHz)	EMISSION LEVEL (dBuV/m)	READ LEVEL (dBuV)	LIMIT (dBuV/m)	MARGIN (dB)	ANTENNA FACTOR (dB/m)	CABLE LOSS (dB)	PREAMP FACTOR (dB)	ANTENNA HEIGHT (cm)	TABLE ANGLE (Degree)	REMARK
5134	38.54	38.33	54	-15.46	31.31	6.2	37.3	106	126	Average
5134	61.1	60.89	74	-12.9	31.31	6.2	37.3	106	126	Peak
5300	96.22	95.7			31.44	6.27	37.19	106	126	Average
5300	105.89	105.37			31.44	6.27	37.19	106	126	Peak
5428	39.2	38.48	54	-14.8	31.53	6.32	37.13	106	126	Average
5428	60.22	59.5	74	-13.78	31.53	6.32	37.13	106	126	Peak

REMARKS:

- Emission Level = Read Level + Antenna Factor + Cable Loss - Preamp Factor
Margin value = Emission level – Limit value
- 5300 MHz: Fundamental frequency.



A D T

EUT TEST CONDITION		MEASUREMENT DETAIL	
CHANNEL	Channel 64	FREQUENCY RANGE	1 GHz ~ 40 GHz
INPUT POWER	120 Vac, 60 Hz	DETECTOR FUNCTION	Peak (PK) Average (AV)
ENVIRONMENTAL CONDITIONS	25 deg. C, 65 % RH	TESTED BY	Gavin Wu

ANTENNA POLARITY & TEST DISTANCE: HORIZONTAL AT 3 M										
FREQ. (MHz)	EMISSION LEVEL (dBuV/m)	READ LEVEL (dBuV)	LIMIT (dBuV/m)	MARGIN (dB)	ANTENNA FACTOR (dB/m)	CABLE LOSS (dB)	PREAMP FACTOR (dB)	ANTENNA HEIGHT (cm)	TABLE ANGLE (Degree)	REMARK
5038	38.31	38.16	54	-15.69	31.24	6.15	37.24	200	180	Average
5038	60.37	60.22	74	-13.63	31.24	6.15	37.24	200	180	Peak
5320	94.7	94.15			31.45	6.29	37.19	200	180	Average
5320	104.13	103.58			31.45	6.29	37.19	200	180	Peak
5420	42.29	41.62	54	-11.71	31.53	6.32	37.18	200	180	Average
5420	59.94	59.27	74	-14.06	31.53	6.32	37.18	200	180	Peak

ANTENNA POLARITY & TEST DISTANCE: VERTICAL AT 3 M										
FREQ. (MHz)	EMISSION LEVEL (dBuV/m)	READ LEVEL (dBuV)	LIMIT (dBuV/m)	MARGIN (dB)	ANTENNA FACTOR (dB/m)	CABLE LOSS (dB)	PREAMP FACTOR (dB)	ANTENNA HEIGHT (cm)	TABLE ANGLE (Degree)	REMARK
5130	38.57	38.36	54	-15.43	31.31	6.2	37.3	119	132	Average
5130	60.37	60.16	74	-13.63	31.31	6.2	37.3	119	132	Peak
5320	96.12	95.57			31.45	6.29	37.19	119	132	Average
5320	105.42	104.87			31.45	6.29	37.19	119	132	Peak
5352	42.77	42.18	54	-11.23	31.48	6.29	37.18	119	132	Average
5352	60.62	60.03	74	-13.38	31.48	6.29	37.18	119	132	Peak

REMARKS:

- Emission Level = Read Level + Antenna Factor + Cable Loss - Preamp Factor
Margin value = Emission level – Limit value
- 5320 MHz: Fundamental frequency.

EUT TEST CONDITION		MEASUREMENT DETAIL	
CHANNEL	Channel 100	FREQUENCY RANGE	1 GHz ~ 40 GHz
INPUT POWER	120 Vac, 60 Hz	DETECTOR FUNCTION	Peak (PK) Average (AV)
ENVIRONMENTAL CONDITIONS	25 deg. C, 65 % RH	TESTED BY	Gavin Wu

ANTENNA POLARITY & TEST DISTANCE: HORIZONTAL AT 3 M										
FREQ. (MHz)	EMISSION LEVEL (dBuV/m)	READ LEVEL (dBuV)	LIMIT (dBuV/m)	MARGIN (dB)	ANTENNA FACTOR (dB/m)	CABLE LOSS (dB)	PREAMP FACTOR (dB)	ANTENNA HEIGHT (cm)	TABLE ANGLE (Degree)	REMARK
5430	38.71	37.97	54	-15.29	31.55	6.32	37.13	207	202	Average
5430	60.44	59.7	74	-13.56	31.55	6.32	37.13	207	202	Peak
5470	59.75	58.92	68.2	-8.45	31.57	6.34	37.08	207	202	Peak
5500	92.06	91.13			31.6	6.36	37.03	207	202	Average
5500	101.76	100.83			31.6	6.36	37.03	207	202	Peak
5725	58.94	57.66	68.2	-9.26	31.96	6.75	37.43	207	202	Peak
ANTENNA POLARITY & TEST DISTANCE: VERTICAL AT 3 M										
FREQ. (MHz)	EMISSION LEVEL (dBuV/m)	READ LEVEL (dBuV)	LIMIT (dBuV/m)	MARGIN (dB)	ANTENNA FACTOR (dB/m)	CABLE LOSS (dB)	PREAMP FACTOR (dB)	ANTENNA HEIGHT (cm)	TABLE ANGLE (Degree)	REMARK
5460	42	41.18	54	-12	31.56	6.34	37.08	200	189	Average
5460	60.9	60.08	74	-13.1	31.56	6.34	37.08	200	189	Peak
5470	59.51	58.68	68.2	-8.69	31.57	6.34	37.08	200	189	Peak
5500	95.87	94.94			31.6	6.36	37.03	200	189	Average
5500	105.07	104.14			31.6	6.36	37.03	200	189	Peak
5725	60.07	58.79	68.2	-8.13	31.96	6.75	37.43	200	189	Peak

REMARKS:

- Emission Level = Read Level + Antenna Factor + Cable Loss - Preamp Factor
Margin value = Emission level – Limit value
- 5500 MHz: Fundamental frequency.
- 5470 MHz & 5725 MHz: Out of restricted band



EUT TEST CONDITION		MEASUREMENT DETAIL	
CHANNEL	Channel 116	FREQUENCY RANGE	1 GHz ~ 40 GHz
INPUT POWER	120 Vac, 60 Hz	DETECTOR FUNCTION	Peak (PK) Average (AV)
ENVIRONMENTAL CONDITIONS	25 deg. C, 65 % RH	TESTED BY	Gavin Wu

ANTENNA POLARITY & TEST DISTANCE: HORIZONTAL AT 3 M										
FREQ. (MHz)	EMISSION LEVEL (dBuV/m)	READ LEVEL (dBuV)	LIMIT (dBuV/m)	MARGIN (dB)	ANTENNA FACTOR (dB/m)	CABLE LOSS (dB)	PREAMP FACTOR (dB)	ANTENNA HEIGHT (cm)	TABLE ANGLE (Degree)	REMARK
5460	38.51	37.69	54	-15.49	31.56	6.34	37.08	220	203	Average
5460	60.19	59.37	74	-13.81	31.56	6.34	37.08	220	203	Peak
5470	59.38	58.55	68.2	-8.82	31.57	6.34	37.08	220	203	Peak
5580	91.35	90.31			31.71	6.49	37.16	220	203	Average
5580	101.17	100.13			31.71	6.49	37.16	220	203	Peak
5725	60.27	58.99	68.2	-7.93	31.96	6.75	37.43	220	203	Peak

ANTENNA POLARITY & TEST DISTANCE: VERTICAL AT 3 M										
FREQ. (MHz)	EMISSION LEVEL (dBuV/m)	READ LEVEL (dBuV)	LIMIT (dBuV/m)	MARGIN (dB)	ANTENNA FACTOR (dB/m)	CABLE LOSS (dB)	PREAMP FACTOR (dB)	ANTENNA HEIGHT (cm)	TABLE ANGLE (Degree)	REMARK
5434	39.06	38.32	54	-14.94	31.55	6.32	37.13	179	138	Average
5434	60.27	59.53	74	-13.73	31.55	6.32	37.13	179	138	Peak
5470	58.49	57.66	68.2	-9.71	31.57	6.34	37.08	179	138	Peak
5580	95.82	94.78			31.71	6.49	37.16	179	138	Average
5580	105.14	104.1			31.71	6.49	37.16	179	138	Peak
5725	59.59	58.31	68.2	-8.61	31.96	6.75	37.43	179	138	Peak

REMARKS:

- Emission Level = Read Level + Antenna Factor + Cable Loss - Preamp Factor
Margin value = Emission level – Limit value
- 5580 MHz: Fundamental frequency.
- 5470 MHz & 5725 MHz: Out of restricted band



A D T

EUT TEST CONDITION		MEASUREMENT DETAIL	
CHANNEL	Channel 140	FREQUENCY RANGE	1 GHz ~ 40 GHz
INPUT POWER	120 Vac, 60 Hz	DETECTOR FUNCTION	Peak (PK) Average (AV)
ENVIRONMENTAL CONDITIONS	25 deg. C, 65 % RH	TESTED BY	Gavin Wu

ANTENNA POLARITY & TEST DISTANCE: HORIZONTAL AT 3 M										
FREQ. (MHz)	EMISSION LEVEL (dBuV/m)	READ LEVEL (dBuV)	LIMIT (dBuV/m)	MARGIN (dB)	ANTENNA FACTOR (dB/m)	CABLE LOSS (dB)	PREAMP FACTOR (dB)	ANTENNA HEIGHT (cm)	TABLE ANGLE (Degree)	REMARK
5360	38.66	38.05	54	-15.34	31.48	6.31	37.18	230	188	Average
5360	60.64	60.03	74	-13.36	31.48	6.31	37.18	230	188	Peak
5470	59.03	58.2	68.2	-9.17	31.57	6.34	37.08	230	188	Peak
5700	91.5	90.31			31.9	6.69	37.4	230	188	Average
5700	101.25	100.06			31.9	6.69	37.4	230	188	Peak
5725	61.63	60.35	68.2	-6.57	31.96	6.75	37.43	230	188	Peak
ANTENNA POLARITY & TEST DISTANCE: VERTICAL AT 3 M										
FREQ. (MHz)	EMISSION LEVEL (dBuV/m)	READ LEVEL (dBuV)	LIMIT (dBuV/m)	MARGIN (dB)	ANTENNA FACTOR (dB/m)	CABLE LOSS (dB)	PREAMP FACTOR (dB)	ANTENNA HEIGHT (cm)	TABLE ANGLE (Degree)	REMARK
5444	38.73	37.97	54	-15.27	31.55	6.34	37.13	191	134	Average
5444	60.31	59.55	74	-13.69	31.55	6.34	37.13	191	134	Peak
5470	58.92	58.09	68.2	-9.28	31.57	6.34	37.08	191	134	Peak
5700	95.76	94.57			31.9	6.69	37.4	191	134	Average
5700	105.39	104.2			31.9	6.69	37.4	191	134	Peak
5725	64.12	62.84	68.2	-4.08	31.96	6.75	37.43	191	134	Peak

REMARKS:

- Emission Level = Read Level + Antenna Factor + Cable Loss - Preamp Factor
Margin value = Emission level – Limit value
- 5700 MHz: Fundamental frequency.
- 5470 MHz & 5725 MHz: Out of restricted band

EUT TEST CONDITION		MEASUREMENT DETAIL	
CHANNEL	Channel 149	FREQUENCY RANGE	1 GHz ~ 40 GHz
INPUT POWER	120 Vac, 60 Hz	DETECTOR FUNCTION	Peak (PK) Average (AV)
ENVIRONMENTAL CONDITIONS	25 deg. C, 65 % RH	TESTED BY	Gavin Wu

ANTENNA POLARITY & TEST DISTANCE: HORIZONTAL AT 3 M										
FREQ. (MHz)	EMISSION LEVEL (dBuV/m)	READ LEVEL (dBuV)	LIMIT (dBuV/m)	MARGIN (dB)	ANTENNA FACTOR (dB/m)	CABLE LOSS (dB)	PREAMP FACTOR (dB)	ANTENNA HEIGHT (cm)	TABLE ANGLE (Degree)	REMARK
5714	60.42	59.23	68.2	-7.78	31.93	6.69	37.43	216	164	Peak
5725	67.2	65.92	78.2	-11	31.96	6.75	37.43	216	164	Peak
5745	96.45	95.18			31.99	6.75	37.47	216	164	Average
5745	105.56	104.29			31.99	6.75	37.47	216	164	Peak
5850	59.32	57.8	78.2	-18.88	32.15	6.88	37.51	216	164	Peak
5861	58.43	56.8	68.2	-9.77	32.18	6.95	37.5	216	164	Peak
ANTENNA POLARITY & TEST DISTANCE: VERTICAL AT 3 M										
FREQ. (MHz)	EMISSION LEVEL (dBuV/m)	READ LEVEL (dBuV)	LIMIT (dBuV/m)	MARGIN (dB)	ANTENNA FACTOR (dB/m)	CABLE LOSS (dB)	PREAMP FACTOR (dB)	ANTENNA HEIGHT (cm)	TABLE ANGLE (Degree)	REMARK
5714	61.05	59.86	68.2	-7.15	31.93	6.69	37.43	131	121	Peak
5725	63.22	61.94	78.2	-14.98	31.96	6.75	37.43	131	121	Peak
5745	90.11	88.84			31.99	6.75	37.47	131	121	Average
5745	100.03	98.76			31.99	6.75	37.47	131	121	Peak
5850	60.17	58.65	78.2	-18.03	32.15	6.88	37.51	131	121	Peak
5861	59.48	57.85	68.2	-8.72	32.18	6.95	37.5	131	121	Peak

REMARKS:

- Emission Level = Read Level + Antenna Factor + Cable Loss - Preamp Factor
Margin value = Emission level – Limit value
- 5745 MHz: Fundamental frequency.
- 5714 MHz & 5725 MHz & 5850 MHz & 5861 MHz: Out of restricted band

EUT TEST CONDITION		MEASUREMENT DETAIL	
CHANNEL	Channel 157	FREQUENCY RANGE	1 GHz ~ 40 GHz
INPUT POWER	120 Vac, 60 Hz	DETECTOR FUNCTION	Peak (PK) Average (AV)
ENVIRONMENTAL CONDITIONS	25 deg. C, 65 % RH	TESTED BY	Gavin Wu

ANTENNA POLARITY & TEST DISTANCE: HORIZONTAL AT 3 M										
FREQ. (MHz)	EMISSION LEVEL (dBuV/m)	READ LEVEL (dBuV)	LIMIT (dBuV/m)	MARGIN (dB)	ANTENNA FACTOR (dB/m)	CABLE LOSS (dB)	PREAMP FACTOR (dB)	ANTENNA HEIGHT (cm)	TABLE ANGLE (Degree)	REMARK
5714	59.8	58.61	68.2	-8.4	31.93	6.69	37.43	190	168	Peak
5725	58.93	57.65	78.2	-19.27	31.96	6.75	37.43	190	168	Peak
5785	97.76	96.44			32.04	6.82	37.54	190	168	Average
5785	107.42	106.1			32.04	6.82	37.54	190	168	Peak
5850	59.34	57.82	78.2	-18.86	32.15	6.88	37.51	190	168	Peak
5861	59.07	57.44	68.2	-9.13	32.18	6.95	37.5	190	168	Peak
ANTENNA POLARITY & TEST DISTANCE: VERTICAL AT 3 M										
FREQ. (MHz)	EMISSION LEVEL (dBuV/m)	READ LEVEL (dBuV)	LIMIT (dBuV/m)	MARGIN (dB)	ANTENNA FACTOR (dB/m)	CABLE LOSS (dB)	PREAMP FACTOR (dB)	ANTENNA HEIGHT (cm)	TABLE ANGLE (Degree)	REMARK
5714	59.25	58.06	68.2	-8.95	31.93	6.69	37.43	136	115	Peak
5725	58.78	57.5	78.2	-19.42	31.96	6.75	37.43	136	115	Peak
5785	91.79	90.47			32.04	6.82	37.54	136	115	Average
5785	101.43	100.11			32.04	6.82	37.54	136	115	Peak
5850	59.63	58.11	78.2	-18.57	32.15	6.88	37.51	136	115	Peak
5861	58.79	57.16	68.2	-9.41	32.18	6.95	37.5	136	115	Peak

REMARKS:

- Emission Level = Read Level + Antenna Factor + Cable Loss - Preamp Factor
Margin value = Emission level – Limit value
- 5785 MHz: Fundamental frequency.
- 5714 MHz & 5725 MHz & 5850 MHz & 5861 MHz: Out of restricted band

EUT TEST CONDITION		MEASUREMENT DETAIL	
CHANNEL	Channel 165	FREQUENCY RANGE	1 GHz ~ 40 GHz
INPUT POWER	120 Vac, 60 Hz	DETECTOR FUNCTION	Peak (PK) Average (AV)
ENVIRONMENTAL CONDITIONS	25 deg. C, 65 % RH	TESTED BY	Gavin Wu

ANTENNA POLARITY & TEST DISTANCE: HORIZONTAL AT 3 M										
FREQ. (MHz)	EMISSION LEVEL (dBuV/m)	READ LEVEL (dBuV)	LIMIT (dBuV/m)	MARGIN (dB)	ANTENNA FACTOR (dB/m)	CABLE LOSS (dB)	PREAMP FACTOR (dB)	ANTENNA HEIGHT (cm)	TABLE ANGLE (Degree)	REMARK
5714	60.38	59.19	68.2	-7.82	31.93	6.69	37.43	188	157	Peak
5725	61.9	60.62	78.2	-16.3	31.96	6.75	37.43	188	157	Peak
5825	97.66	96.19			32.12	6.88	37.53	188	157	Average
5825	106.95	105.48			32.12	6.88	37.53	188	157	Peak
5850	72.27	70.75	78.2	-5.93	32.15	6.88	37.51	188	157	Peak
5861	65.63	64	68.2	-2.57	32.18	6.95	37.5	188	157	Peak
ANTENNA POLARITY & TEST DISTANCE: VERTICAL AT 3 M										
FREQ. (MHz)	EMISSION LEVEL (dBuV/m)	READ LEVEL (dBuV)	LIMIT (dBuV/m)	MARGIN (dB)	ANTENNA FACTOR (dB/m)	CABLE LOSS (dB)	PREAMP FACTOR (dB)	ANTENNA HEIGHT (cm)	TABLE ANGLE (Degree)	REMARK
5714	59.11	57.92	68.2	-9.09	31.93	6.69	37.43	109	116	Peak
5725	59.87	58.59	78.2	-18.33	31.96	6.75	37.43	109	116	Peak
5825	92.26	90.79			32.12	6.88	37.53	109	116	Average
5825	101.57	100.1			32.12	6.88	37.53	109	116	Peak
5850	65.15	63.63	78.2	-13.05	32.15	6.88	37.51	109	116	Peak
5861	59.57	57.94	68.2	-8.63	32.18	6.95	37.5	109	116	Peak

REMARKS:

- Emission Level = Read Level + Antenna Factor + Cable Loss - Preamp Factor
Margin value = Emission level – Limit value
- 5825MHz: Fundamental frequency.
- 5714 MHz & 5725 MHz & 5850 MHz & 5861 MHz: Out of restricted band

802.11n (HT20)

EUT TEST CONDITION		MEASUREMENT DETAIL	
CHANNEL	Channel 36	FREQUENCY RANGE	1 GHz ~ 40 GHz
INPUT POWER	120 Vac, 60 Hz	DETECTOR FUNCTION	Peak (PK) Average (AV)
ENVIRONMENTAL CONDITIONS	25 deg. C, 65 % RH	TESTED BY	Gavin Wu

ANTENNA POLARITY & TEST DISTANCE: HORIZONTAL AT 3 M

FREQ. (MHz)	EMISSION LEVEL (dBuV/m)	READ LEVEL (dBuV)	LIMIT (dBuV/m)	MARGIN (dB)	ANTENNA FACTOR (dB/m)	CABLE LOSS (dB)	PREAMP FACTOR (dB)	ANTENNA HEIGHT (cm)	TABLE ANGLE (Degree)	REMARK
5016	39.13	39	54	-14.87	31.21	6.15	37.23	101	219	Average
5016	60.48	60.35	74	-13.52	31.21	6.15	37.23	101	219	Peak
5180	90.87	90.64			31.35	6.22	37.34	101	219	Average
5180	100.34	100.11			31.35	6.22	37.34	101	219	Peak
5384	38.23	37.59	54	-15.77	31.51	6.31	37.18	101	219	Average
5384	59.78	59.14	74	-14.22	31.51	6.31	37.18	101	219	Peak

ANTENNA POLARITY & TEST DISTANCE: VERTICAL AT 3 M

FREQ. (MHz)	EMISSION LEVEL (dBuV/m)	READ LEVEL (dBuV)	LIMIT (dBuV/m)	MARGIN (dB)	ANTENNA FACTOR (dB/m)	CABLE LOSS (dB)	PREAMP FACTOR (dB)	ANTENNA HEIGHT (cm)	TABLE ANGLE (Degree)	REMARK
5146	44.54	44.34	54	-9.46	31.32	6.2	37.32	235	195	Average
5146	62.18	61.98	74	-11.82	31.32	6.2	37.32	235	195	Peak
5180	94.79	94.56			31.35	6.22	37.34	235	195	Average
5180	104.76	104.53			31.35	6.22	37.34	235	195	Peak
5420	38.25	37.58	54	-15.75	31.53	6.32	37.18	235	195	Average
5420	61.65	60.98	74	-12.35	31.53	6.32	37.18	235	195	Peak

REMARKS:

- Emission Level = Read Level + Antenna Factor + Cable Loss - Preamp Factor
Margin value = Emission level – Limit value
- 5180 MHz: Fundamental frequency.



EUT TEST CONDITION		MEASUREMENT DETAIL	
CHANNEL	Channel 44	FREQUENCY RANGE	1 GHz ~ 40 GHz
INPUT POWER	120 Vac, 60 Hz	DETECTOR FUNCTION	Peak (PK) Average (AV)
ENVIRONMENTAL CONDITIONS	25 deg. C, 65 % RH	TESTED BY	Gavin Wu

ANTENNA POLARITY & TEST DISTANCE: HORIZONTAL AT 3 M										
FREQ. (MHz)	EMISSION LEVEL (dBuV/m)	READ LEVEL (dBuV)	LIMIT (dBuV/m)	MARGIN (dB)	ANTENNA FACTOR (dB/m)	CABLE LOSS (dB)	PREAMP FACTOR (dB)	ANTENNA HEIGHT (cm)	TABLE ANGLE (Degree)	REMARK
5112	38.13	37.93	54	-15.87	31.29	6.19	37.28	204	192	Average
5112	61.03	60.83	74	-12.97	31.29	6.19	37.28	204	192	Peak
5220	91.28	91.03			31.37	6.24	37.36	204	192	Average
5220	100.46	100.21			31.37	6.24	37.36	204	192	Peak
5460	38.32	37.5	54	-15.68	31.56	6.34	37.08	204	192	Average
5460	60.7	59.88	74	-13.3	31.56	6.34	37.08	204	192	Peak
ANTENNA POLARITY & TEST DISTANCE: VERTICAL AT 3 M										
FREQ. (MHz)	EMISSION LEVEL (dBuV/m)	READ LEVEL (dBuV)	LIMIT (dBuV/m)	MARGIN (dB)	ANTENNA FACTOR (dB/m)	CABLE LOSS (dB)	PREAMP FACTOR (dB)	ANTENNA HEIGHT (cm)	TABLE ANGLE (Degree)	REMARK
5024	39.11	38.97	54	-14.89	31.23	6.15	37.24	197	156	Average
5024	61.17	61.03	74	-12.83	31.23	6.15	37.24	197	156	Peak
5220	95.76	95.51			31.37	6.24	37.36	197	156	Average
5220	104.79	104.54			31.37	6.24	37.36	197	156	Peak
5432	38.47	37.73	54	-15.53	31.55	6.32	37.13	197	156	Average
5432	59.79	59.05	74	-14.21	31.55	6.32	37.13	197	156	Peak

REMARKS:

- Emission Level = Read Level + Antenna Factor + Cable Loss - Preamp Factor
Margin value = Emission level – Limit value
- 5220 MHz: Fundamental frequency.

EUT TEST CONDITION		MEASUREMENT DETAIL	
CHANNEL	Channel 48	FREQUENCY RANGE	1 GHz ~ 40 GHz
INPUT POWER	120 Vac, 60 Hz	DETECTOR FUNCTION	Peak (PK) Average (AV)
ENVIRONMENTAL CONDITIONS	25 deg. C, 65 % RH	TESTED BY	Gavin Wu

ANTENNA POLARITY & TEST DISTANCE: HORIZONTAL AT 3 M										
FREQ. (MHz)	EMISSION LEVEL (dBuV/m)	READ LEVEL (dBuV)	LIMIT (dBuV/m)	MARGIN (dB)	ANTENNA FACTOR (dB/m)	CABLE LOSS (dB)	PREAMP FACTOR (dB)	ANTENNA HEIGHT (cm)	TABLE ANGLE (Degree)	REMARK
5096	38.05	37.86	54	-15.95	31.28	6.19	37.28	200	194	Average
5096	60.22	60.03	74	-13.78	31.28	6.19	37.28	200	194	Peak
5240	91.16	90.84			31.39	6.25	37.32	200	194	Average
5240	100.54	100.22			31.39	6.25	37.32	200	194	Peak
5446	38.49	37.72	54	-15.51	31.56	6.34	37.13	200	194	Average
5446	60.56	59.79	74	-13.44	31.56	6.34	37.13	200	194	Peak
ANTENNA POLARITY & TEST DISTANCE: VERTICAL AT 3 M										
FREQ. (MHz)	EMISSION LEVEL (dBuV/m)	READ LEVEL (dBuV)	LIMIT (dBuV/m)	MARGIN (dB)	ANTENNA FACTOR (dB/m)	CABLE LOSS (dB)	PREAMP FACTOR (dB)	ANTENNA HEIGHT (cm)	TABLE ANGLE (Degree)	REMARK
5128	38.62	38.41	54	-15.38	31.31	6.2	37.3	202	146	Average
5128	60.28	60.07	74	-13.72	31.31	6.2	37.3	202	146	Peak
5240	96.12	95.8			31.39	6.25	37.32	202	146	Average
5240	105.53	105.21			31.39	6.25	37.32	202	146	Peak
5450	38.78	37.96	54	-15.22	31.56	6.34	37.08	202	146	Average
5450	61.02	60.2	74	-12.98	31.56	6.34	37.08	202	146	Peak

REMARKS:

- Emission Level = Read Level + Antenna Factor + Cable Loss - Preamp Factor
Margin value = Emission level – Limit value
- 5240 MHz: Fundamental frequency.



A D T

EUT TEST CONDITION		MEASUREMENT DETAIL	
CHANNEL	Channel 52	FREQUENCY RANGE	1 GHz ~ 40 GHz
INPUT POWER	120 Vac, 60 Hz	DETECTOR FUNCTION	Peak (PK) Average (AV)
ENVIRONMENTAL CONDITIONS	25 deg. C, 65 % RH	TESTED BY	Gavin Wu

ANTENNA POLARITY & TEST DISTANCE: HORIZONTAL AT 3 M										
FREQ. (MHz)	EMISSION LEVEL (dBuV/m)	READ LEVEL (dBuV)	LIMIT (dBuV/m)	MARGIN (dB)	ANTENNA FACTOR (dB/m)	CABLE LOSS (dB)	PREAMP FACTOR (dB)	ANTENNA HEIGHT (cm)	TABLE ANGLE (Degree)	REMARK
5078	38.4	38.23	54	-15.6	31.27	6.17	37.27	211	162	Average
5078	59.59	59.42	74	-14.41	31.27	6.17	37.27	211	162	Peak
5260	94.56	94.17			31.41	6.25	37.27	211	162	Average
5260	103.66	103.27			31.41	6.25	37.27	211	162	Peak
5448	38.45	37.68	54	-15.55	31.56	6.34	37.13	211	162	Average
5448	60	59.23	74	-14	31.56	6.34	37.13	211	162	Peak

ANTENNA POLARITY & TEST DISTANCE: VERTICAL AT 3 M										
FREQ. (MHz)	EMISSION LEVEL (dBuV/m)	READ LEVEL (dBuV)	LIMIT (dBuV/m)	MARGIN (dB)	ANTENNA FACTOR (dB/m)	CABLE LOSS (dB)	PREAMP FACTOR (dB)	ANTENNA HEIGHT (cm)	TABLE ANGLE (Degree)	REMARK
5028	38.37	38.23	54	-15.63	31.23	6.15	37.24	127	140	Average
5028	60.49	60.35	74	-13.51	31.23	6.15	37.24	127	140	Peak
5260	95.09	94.7			31.41	6.25	37.27	127	140	Average
5260	104.51	104.12			31.41	6.25	37.27	127	140	Peak
5398	38.41	37.75	54	-15.59	31.52	6.32	37.18	127	140	Average
5398	60.02	59.36	74	-13.98	31.52	6.32	37.18	127	140	Peak

REMARKS:

- Emission Level = Read Level + Antenna Factor + Cable Loss - Preamp Factor
Margin value = Emission level – Limit value
- 5260 MHz: Fundamental frequency.



A D T

EUT TEST CONDITION		MEASUREMENT DETAIL	
CHANNEL	Channel 60	FREQUENCY RANGE	1 GHz ~ 40 GHz
INPUT POWER	120 Vac, 60 Hz	DETECTOR FUNCTION	Peak (PK) Average (AV)
ENVIRONMENTAL CONDITIONS	25 deg. C, 65 % RH	TESTED BY	Gavin Wu

ANTENNA POLARITY & TEST DISTANCE: HORIZONTAL AT 3 M										
FREQ. (MHz)	EMISSION LEVEL (dBuV/m)	READ LEVEL (dBuV)	LIMIT (dBuV/m)	MARGIN (dB)	ANTENNA FACTOR (dB/m)	CABLE LOSS (dB)	PREAMP FACTOR (dB)	ANTENNA HEIGHT (cm)	TABLE ANGLE (Degree)	REMARK
5118	38.38	38.18	54	-15.62	31.29	6.19	37.28	212	193	Average
5118	59.66	59.46	74	-14.34	31.29	6.19	37.28	212	193	Peak
5300	94.44	93.92			31.44	6.27	37.19	212	193	Average
5300	103.87	103.35			31.44	6.27	37.19	212	193	Peak
5422	38.77	38.1	54	-15.23	31.53	6.32	37.18	212	193	Average
5422	60.01	59.34	74	-13.99	31.53	6.32	37.18	212	193	Peak

ANTENNA POLARITY & TEST DISTANCE: VERTICAL AT 3 M										
FREQ. (MHz)	EMISSION LEVEL (dBuV/m)	READ LEVEL (dBuV)	LIMIT (dBuV/m)	MARGIN (dB)	ANTENNA FACTOR (dB/m)	CABLE LOSS (dB)	PREAMP FACTOR (dB)	ANTENNA HEIGHT (cm)	TABLE ANGLE (Degree)	REMARK
5146	38.27	38.07	54	-15.73	31.32	6.2	37.32	119	134	Average
5146	60.57	60.37	74	-13.43	31.32	6.2	37.32	119	134	Peak
5300	95.29	94.77			31.44	6.27	37.19	119	134	Average
5300	104.63	104.11			31.44	6.27	37.19	119	134	Peak
5416	39.34	38.67	54	-14.66	31.53	6.32	37.18	119	134	Average
5416	61.16	60.49	74	-12.84	31.53	6.32	37.18	119	134	Peak

REMARKS:

- Emission Level = Read Level + Antenna Factor + Cable Loss - Preamp Factor
Margin value = Emission level – Limit value
- 5300 MHz: Fundamental frequency.

EUT TEST CONDITION		MEASUREMENT DETAIL	
CHANNEL	Channel 64	FREQUENCY RANGE	1 GHz ~ 40 GHz
INPUT POWER	120 Vac, 60 Hz	DETECTOR FUNCTION	Peak (PK) Average (AV)
ENVIRONMENTAL CONDITIONS	25 deg. C, 65 % RH	TESTED BY	Gavin Wu

ANTENNA POLARITY & TEST DISTANCE: HORIZONTAL AT 3 M										
FREQ. (MHz)	EMISSION LEVEL (dBuV/m)	READ LEVEL (dBuV)	LIMIT (dBuV/m)	MARGIN (dB)	ANTENNA FACTOR (dB/m)	CABLE LOSS (dB)	PREAMP FACTOR (dB)	ANTENNA HEIGHT (cm)	TABLE ANGLE (Degree)	REMARK
5144	38.37	38.17	54	-15.63	31.32	6.2	37.32	186	183	Average
5144	60.69	60.49	74	-13.31	31.32	6.2	37.32	186	183	Peak
5320	94.41	93.86			31.45	6.29	37.19	186	183	Average
5320	103.7	103.15			31.45	6.29	37.19	186	183	Peak
5350	41.72	41.13	54	-12.28	31.48	6.29	37.18	186	183	Average
5350	60.87	60.28	74	-13.13	31.48	6.29	37.18	186	183	Peak
ANTENNA POLARITY & TEST DISTANCE: VERTICAL AT 3 M										
FREQ. (MHz)	EMISSION LEVEL (dBuV/m)	READ LEVEL (dBuV)	LIMIT (dBuV/m)	MARGIN (dB)	ANTENNA FACTOR (dB/m)	CABLE LOSS (dB)	PREAMP FACTOR (dB)	ANTENNA HEIGHT (cm)	TABLE ANGLE (Degree)	REMARK
5074	38.36	38.19	54	-15.64	31.27	6.17	37.27	119	125	Average
5074	61.17	61	74	-12.83	31.27	6.17	37.27	119	125	Peak
5320	94.98	94.43			31.45	6.29	37.19	119	125	Average
5320	104.69	104.14			31.45	6.29	37.19	119	125	Peak
5360	42.95	42.34	54	-11.05	31.48	6.31	37.18	119	125	Average
5360	60.29	59.68	74	-13.71	31.48	6.31	37.18	119	125	Peak

REMARKS:

- Emission Level = Read Level + Antenna Factor + Cable Loss - Preamp Factor
Margin value = Emission level – Limit value
- 5320 MHz: Fundamental frequency.

EUT TEST CONDITION		MEASUREMENT DETAIL	
CHANNEL	Channel 100	FREQUENCY RANGE	1 GHz ~ 40 GHz
INPUT POWER	120 Vac, 60 Hz	DETECTOR FUNCTION	Peak (PK) Average (AV)
ENVIRONMENTAL CONDITIONS	25 deg. C, 65 % RH	TESTED BY	Gavin Wu

ANTENNA POLARITY & TEST DISTANCE: HORIZONTAL AT 3 M										
FREQ. (MHz)	EMISSION LEVEL (dBuV/m)	READ LEVEL (dBuV)	LIMIT (dBuV/m)	MARGIN (dB)	ANTENNA FACTOR (dB/m)	CABLE LOSS (dB)	PREAMP FACTOR (dB)	ANTENNA HEIGHT (cm)	TABLE ANGLE (Degree)	REMARK
5432	38.44	37.7	54	-15.56	31.55	6.32	37.13	207	194	Average
5432	60.4	59.66	74	-13.6	31.55	6.32	37.13	207	194	Peak
5470	59.47	58.64	68.2	-8.73	31.57	6.34	37.08	207	194	Peak
5500	89.56	88.63			31.6	6.36	37.03	207	194	Average
5500	100.16	99.23			31.6	6.36	37.03	207	194	Peak
5725	58.45	57.17	68.2	-9.75	31.96	6.75	37.43	207	194	Peak
ANTENNA POLARITY & TEST DISTANCE: VERTICAL AT 3 M										
FREQ. (MHz)	EMISSION LEVEL (dBuV/m)	READ LEVEL (dBuV)	LIMIT (dBuV/m)	MARGIN (dB)	ANTENNA FACTOR (dB/m)	CABLE LOSS (dB)	PREAMP FACTOR (dB)	ANTENNA HEIGHT (cm)	TABLE ANGLE (Degree)	REMARK
5404	39.06	38.4	54	-14.94	31.52	6.32	37.18	191	134	Average
5404	60.43	59.77	74	-13.57	31.52	6.32	37.18	191	134	Peak
5470	60.89	60.06	68.2	-7.31	31.57	6.34	37.08	191	134	Peak
5500	93.39	92.46			31.6	6.36	37.03	191	134	Average
5500	104.26	103.33			31.6	6.36	37.03	191	134	Peak
5725	60.17	58.89	68.2	-8.03	31.96	6.75	37.43	191	134	Peak

REMARKS:

- Emission Level = Read Level + Antenna Factor + Cable Loss - Preamp Factor
Margin value = Emission level – Limit value
- 5500 MHz: Fundamental frequency.
- 5470 MHz & 5725 MHz: Out of restricted band

EUT TEST CONDITION		MEASUREMENT DETAIL	
CHANNEL	Channel 116	FREQUENCY RANGE	1 GHz ~ 40 GHz
INPUT POWER	120 Vac, 60 Hz	DETECTOR FUNCTION	Peak (PK) Average (AV)
ENVIRONMENTAL CONDITIONS	25 deg. C, 65 % RH	TESTED BY	Gavin Wu

ANTENNA POLARITY & TEST DISTANCE: HORIZONTAL AT 3 M										
FREQ. (MHz)	EMISSION LEVEL (dBuV/m)	READ LEVEL (dBuV)	LIMIT (dBuV/m)	MARGIN (dB)	ANTENNA FACTOR (dB/m)	CABLE LOSS (dB)	PREAMP FACTOR (dB)	ANTENNA HEIGHT (cm)	TABLE ANGLE (Degree)	REMARK
5442	38.33	37.57	54	-15.67	31.55	6.34	37.13	206	186	Average
5442	59.73	58.97	74	-14.27	31.55	6.34	37.13	206	186	Peak
5470	59.7	58.87	68.2	-8.5	31.57	6.34	37.08	206	186	Peak
5580	89.94	88.9			31.71	6.49	37.16	206	186	Average
5580	100.58	99.54			31.71	6.49	37.16	206	186	Peak
5725	59.88	58.6	68.2	-8.32	31.96	6.75	37.43	206	186	Peak
ANTENNA POLARITY & TEST DISTANCE: VERTICAL AT 3 M										
FREQ. (MHz)	EMISSION LEVEL (dBuV/m)	READ LEVEL (dBuV)	LIMIT (dBuV/m)	MARGIN (dB)	ANTENNA FACTOR (dB/m)	CABLE LOSS (dB)	PREAMP FACTOR (dB)	ANTENNA HEIGHT (cm)	TABLE ANGLE (Degree)	REMARK
5432	39.16	38.42	54	-14.84	31.55	6.32	37.13	204	143	Average
5432	60.2	59.46	74	-13.8	31.55	6.32	37.13	204	143	Peak
5470	59.59	58.76	68.2	-8.61	31.57	6.34	37.08	204	143	Peak
5580	94.61	93.57			31.71	6.49	37.16	204	143	Average
5580	104.23	103.19			31.71	6.49	37.16	204	143	Peak
5725	59.2	57.92	68.2	-9	31.96	6.75	37.43	204	143	Peak

REMARKS:

- Emission Level = Read Level + Antenna Factor + Cable Loss - Preamp Factor
Margin value = Emission level – Limit value
- 5580 MHz: Fundamental frequency.
- 5470 MHz & 5725 MHz: Out of restricted band



EUT TEST CONDITION		MEASUREMENT DETAIL	
CHANNEL	Channel 140	FREQUENCY RANGE	1 GHz ~ 40 GHz
INPUT POWER	120 Vac, 60 Hz	DETECTOR FUNCTION	Peak (PK) Average (AV)
ENVIRONMENTAL CONDITIONS	25 deg. C, 65 % RH	TESTED BY	Gavin Wu

ANTENNA POLARITY & TEST DISTANCE: HORIZONTAL AT 3 M										
FREQ. (MHz)	EMISSION LEVEL (dBuV/m)	READ LEVEL (dBuV)	LIMIT (dBuV/m)	MARGIN (dB)	ANTENNA FACTOR (dB/m)	CABLE LOSS (dB)	PREAMP FACTOR (dB)	ANTENNA HEIGHT (cm)	TABLE ANGLE (Degree)	REMARK
5348	38.11	37.52	54	-15.89	31.48	6.29	37.18	236	181	Average
5348	60.14	59.55	74	-13.86	31.48	6.29	37.18	236	181	Peak
5470	58.52	57.69	68.2	-9.68	31.57	6.34	37.08	236	181	Peak
5700	91.55	90.36			31.9	6.69	37.4	236	181	Average
5700	101.99	100.8			31.9	6.69	37.4	236	181	Peak
5725	62.98	61.7	68.2	-5.22	31.96	6.75	37.43	236	181	Peak

ANTENNA POLARITY & TEST DISTANCE: VERTICAL AT 3 M										
FREQ. (MHz)	EMISSION LEVEL (dBuV/m)	READ LEVEL (dBuV)	LIMIT (dBuV/m)	MARGIN (dB)	ANTENNA FACTOR (dB/m)	CABLE LOSS (dB)	PREAMP FACTOR (dB)	ANTENNA HEIGHT (cm)	TABLE ANGLE (Degree)	REMARK
5438	38.51	37.75	54	-15.49	31.55	6.34	37.13	191	133	Average
5438	61.4	60.64	74	-12.6	31.55	6.34	37.13	191	133	Peak
5470	61.37	60.54	68.2	-6.83	31.57	6.34	37.08	191	133	Peak
5700	94.31	93.12			31.9	6.69	37.4	191	133	Average
5700	104.78	103.59			31.9	6.69	37.4	191	133	Peak
5725	66.35	65.07	68.2	-1.85	31.96	6.75	37.43	191	133	Peak

REMARKS:

- Emission Level = Read Level + Antenna Factor + Cable Loss - Preamp Factor
Margin value = Emission level – Limit value
- 5700 MHz: Fundamental frequency.
- 5470 MHz & 5725 MHz: Out of restricted band



A D T

EUT TEST CONDITION		MEASUREMENT DETAIL	
CHANNEL	Channel 149	FREQUENCY RANGE	1 GHz ~ 40 GHz
INPUT POWER	120 Vac, 60 Hz	DETECTOR FUNCTION	Peak (PK) Average (AV)
ENVIRONMENTAL CONDITIONS	25 deg. C, 65 % RH	TESTED BY	Gavin Wu

ANTENNA POLARITY & TEST DISTANCE: HORIZONTAL AT 3 M										
FREQ. (MHz)	EMISSION LEVEL (dBuV/m)	READ LEVEL (dBuV)	LIMIT (dBuV/m)	MARGIN (dB)	ANTENNA FACTOR (dB/m)	CABLE LOSS (dB)	PREAMP FACTOR (dB)	ANTENNA HEIGHT (cm)	TABLE ANGLE (Degree)	REMARK
5714	61.16	59.97	68.2	-7.04	31.93	6.69	37.43	200	175	Peak
5725	67.23	65.95	78.2	-10.97	31.96	6.75	37.43	200	175	Peak
5745	96.24	94.97			31.99	6.75	37.47	200	175	Average
5745	105.77	104.5			31.99	6.75	37.47	200	175	Peak
5850	60.64	59.12	78.2	-17.56	32.15	6.88	37.51	200	175	Peak
5861	60.02	58.39	68.2	-8.18	32.18	6.95	37.5	200	175	Peak
ANTENNA POLARITY & TEST DISTANCE: VERTICAL AT 3 M										
FREQ. (MHz)	EMISSION LEVEL (dBuV/m)	READ LEVEL (dBuV)	LIMIT (dBuV/m)	MARGIN (dB)	ANTENNA FACTOR (dB/m)	CABLE LOSS (dB)	PREAMP FACTOR (dB)	ANTENNA HEIGHT (cm)	TABLE ANGLE (Degree)	REMARK
5714	61.88	60.69	68.2	-6.32	31.93	6.69	37.43	105	119	Peak
5725	68.21	66.93	78.2	-9.99	31.96	6.75	37.43	105	119	Peak
5745	91.74	90.47			31.99	6.75	37.47	105	119	Average
5745	101.47	100.2			31.99	6.75	37.47	105	119	Peak
5850	61.34	59.82	78.2	-16.86	32.15	6.88	37.51	105	119	Peak
5861	61.6	59.97	68.2	-6.6	32.18	6.95	37.5	105	119	Peak

REMARKS:

- Emission Level = Read Level + Antenna Factor + Cable Loss - Preamp Factor
Margin value = Emission level – Limit value
- 5745 MHz: Fundamental frequency.
- 5714 MHz & 5725 MHz & 5850 MHz & 5861 MHz: Out of restricted band



EUT TEST CONDITION		MEASUREMENT DETAIL	
CHANNEL	Channel 157	FREQUENCY RANGE	1 GHz ~ 40 GHz
INPUT POWER	120 Vac, 60 Hz	DETECTOR FUNCTION	Peak (PK) Average (AV)
ENVIRONMENTAL CONDITIONS	25 deg. C, 65 % RH	TESTED BY	Gavin Wu

ANTENNA POLARITY & TEST DISTANCE: HORIZONTAL AT 3 M										
FREQ. (MHz)	EMISSION LEVEL (dBuV/m)	READ LEVEL (dBuV)	LIMIT (dBuV/m)	MARGIN (dB)	ANTENNA FACTOR (dB/m)	CABLE LOSS (dB)	PREAMP FACTOR (dB)	ANTENNA HEIGHT (cm)	TABLE ANGLE (Degree)	REMARK
5714	61.1	59.91	68.2	-7.1	31.93	6.69	37.43	200	174	Peak
5725	61.21	59.93	78.2	-16.99	31.96	6.75	37.43	200	174	Peak
5785	96.64	95.32			32.04	6.82	37.54	200	174	Average
5785	106.72	105.4			32.04	6.82	37.54	200	174	Peak
5850	61.22	59.7	78.2	-16.98	32.15	6.88	37.51	200	174	Peak
5861	62.06	60.43	68.2	-6.14	32.18	6.95	37.5	200	174	Peak
ANTENNA POLARITY & TEST DISTANCE: VERTICAL AT 3 M										
FREQ. (MHz)	EMISSION LEVEL (dBuV/m)	READ LEVEL (dBuV)	LIMIT (dBuV/m)	MARGIN (dB)	ANTENNA FACTOR (dB/m)	CABLE LOSS (dB)	PREAMP FACTOR (dB)	ANTENNA HEIGHT (cm)	TABLE ANGLE (Degree)	REMARK
5714	60.67	59.48	68.2	-7.53	31.93	6.69	37.43	151	129	Peak
5725	61.27	60.05	78.2	-16.93	31.96	6.69	37.43	151	129	Peak
5785	92.26	90.94			32.04	6.82	37.54	151	129	Average
5785	102.32	101			32.04	6.82	37.54	151	129	Peak
5850	62.2	60.68	78.2	-16	32.15	6.88	37.51	151	129	Peak
5861	61.52	59.89	68.2	-6.68	32.18	6.95	37.5	151	129	Peak

REMARKS:

- Emission Level = Read Level + Antenna Factor + Cable Loss - Preamp Factor
Margin value = Emission level – Limit value
- 5785 MHz: Fundamental frequency.
- 5714 MHz & 5725 MHz & 5850 MHz & 5861 MHz: Out of restricted band

EUT TEST CONDITION		MEASUREMENT DETAIL	
CHANNEL	Channel 165	FREQUENCY RANGE	1 GHz ~ 40 GHz
INPUT POWER	120 Vac, 60 Hz	DETECTOR FUNCTION	Peak (PK) Average (AV)
ENVIRONMENTAL CONDITIONS	25 deg. C, 65 % RH	TESTED BY	Gavin Wu

ANTENNA POLARITY & TEST DISTANCE: HORIZONTAL AT 3 M										
FREQ. (MHz)	EMISSION LEVEL (dBuV/m)	READ LEVEL (dBuV)	LIMIT (dBuV/m)	MARGIN (dB)	ANTENNA FACTOR (dB/m)	CABLE LOSS (dB)	PREAMP FACTOR (dB)	ANTENNA HEIGHT (cm)	TABLE ANGLE (Degree)	REMARK
5714	60.96	59.77	68.2	-7.24	31.93	6.69	37.43	207	166	Peak
5725	60.13	58.85	78.2	-18.07	31.96	6.75	37.43	207	166	Peak
5825	96.44	94.97			32.12	6.88	37.53	207	166	Average
5825	105.68	104.21			32.12	6.88	37.53	207	166	Peak
5850	75.18	73.66	78.2	-3.02	32.15	6.88	37.51	207	166	Peak
5861	64.68	63.05	68.2	-3.52	32.18	6.95	37.5	207	166	Peak
ANTENNA POLARITY & TEST DISTANCE: VERTICAL AT 3 M										
FREQ. (MHz)	EMISSION LEVEL (dBuV/m)	READ LEVEL (dBuV)	LIMIT (dBuV/m)	MARGIN (dB)	ANTENNA FACTOR (dB/m)	CABLE LOSS (dB)	PREAMP FACTOR (dB)	ANTENNA HEIGHT (cm)	TABLE ANGLE (Degree)	REMARK
5714	60.45	59.26	68.2	-7.75	31.93	6.69	37.43	102	126	Peak
5725	59.98	58.7	78.2	-18.22	31.96	6.75	37.43	102	126	Peak
5825	91.74	90.27			32.12	6.88	37.53	102	126	Average
5825	101.14	99.67			32.12	6.88	37.53	102	126	Peak
5850	67.44	65.92	78.2	-10.76	32.15	6.88	37.51	102	126	Peak
5861	60.58	58.95	68.2	-7.62	32.18	6.95	37.5	102	126	Peak

REMARKS:

- Emission Level = Read Level + Antenna Factor + Cable Loss - Preamp Factor
Margin value = Emission level – Limit value
- 5825 MHz: Fundamental frequency.
- 5714 MHz & 5725 MHz & 5850 MHz & 5861 MHz: Out of restricted band

802.11n (HT40)

EUT TEST CONDITION		MEASUREMENT DETAIL	
CHANNEL	Channel 38	FREQUENCY RANGE	1 GHz ~ 40 GHz
INPUT POWER	120 Vac, 60 Hz	DETECTOR FUNCTION	Peak (PK) Average (AV)
ENVIRONMENTAL CONDITIONS	25 deg. C, 65 % RH	TESTED BY	Gavin Wu

ANTENNA POLARITY & TEST DISTANCE: HORIZONTAL AT 3 M

FREQ. (MHz)	EMISSION LEVEL (dBuV/m)	READ LEVEL (dBuV)	LIMIT (dBuV/m)	MARGIN (dB)	ANTENNA FACTOR (dB/m)	CABLE LOSS (dB)	PREAMP FACTOR (dB)	ANTENNA HEIGHT (cm)	TABLE ANGLE (Degree)	REMARK
5150	42.99	42.79	54	-11.01	31.32	6.2	37.32	215	191	Average
5150	61.46	61.26	74	-12.54	31.32	6.2	37.32	215	191	Peak
5190	85.43	85.2			31.35	6.22	37.34	215	191	Average
5190	95.3	95.07			31.35	6.22	37.34	215	191	Peak
5410	38.35	37.69	54	-15.65	31.52	6.32	37.18	215	191	Average
5410	61.1	60.44	74	-12.9	31.52	6.32	37.18	215	191	Peak

ANTENNA POLARITY & TEST DISTANCE: VERTICAL AT 3 M

FREQ. (MHz)	EMISSION LEVEL (dBuV/m)	READ LEVEL (dBuV)	LIMIT (dBuV/m)	MARGIN (dB)	ANTENNA FACTOR (dB/m)	CABLE LOSS (dB)	PREAMP FACTOR (dB)	ANTENNA HEIGHT (cm)	TABLE ANGLE (Degree)	REMARK
5150	50.22	50.02	54	-3.78	31.32	6.2	37.32	208	165	Average
5150	66.36	66.16	74	-7.64	31.32	6.2	37.32	208	165	Peak
5190	90.88	90.65			31.35	6.22	37.34	208	165	Average
5190	100.33	100.1			31.35	6.22	37.34	208	165	Peak
5424	38.53	37.86	54	-15.47	31.53	6.32	37.18	208	165	Average
5424	60.36	59.69	74	-13.64	31.53	6.32	37.18	208	165	Peak

REMARKS:

- Emission Level = Read Level + Antenna Factor + Cable Loss - Preamp Factor
Margin value = Emission level – Limit value
- 5190 MHz: Fundamental frequency.

EUT TEST CONDITION		MEASUREMENT DETAIL	
CHANNEL	Channel 46	FREQUENCY RANGE	1 GHz ~ 40 GHz
INPUT POWER	120 Vac, 60 Hz	DETECTOR FUNCTION	Peak (PK) Average (AV)
ENVIRONMENTAL CONDITIONS	25 deg. C, 65 % RH	TESTED BY	Gavin Wu

ANTENNA POLARITY & TEST DISTANCE: HORIZONTAL AT 3 M										
FREQ. (MHz)	EMISSION LEVEL (dBuV/m)	READ LEVEL (dBuV)	LIMIT (dBuV/m)	MARGIN (dB)	ANTENNA FACTOR (dB/m)	CABLE LOSS (dB)	PREAMP FACTOR (dB)	ANTENNA HEIGHT (cm)	TABLE ANGLE (Degree)	REMARK
5116	38.16	37.96	54	-15.84	31.29	6.19	37.28	212	191	Average
5116	59.49	59.29	74	-14.51	31.29	6.19	37.28	212	191	Peak
5230	88.99	88.68			31.39	6.24	37.32	212	191	Average
5230	98.93	98.62			31.39	6.24	37.32	212	191	Peak
5350	38.33	37.74	54	-15.67	31.48	6.29	37.18	212	191	Average
5350	60.24	59.65	74	-13.76	31.48	6.29	37.18	212	191	Peak
ANTENNA POLARITY & TEST DISTANCE: VERTICAL AT 3 M										
FREQ. (MHz)	EMISSION LEVEL (dBuV/m)	READ LEVEL (dBuV)	LIMIT (dBuV/m)	MARGIN (dB)	ANTENNA FACTOR (dB/m)	CABLE LOSS (dB)	PREAMP FACTOR (dB)	ANTENNA HEIGHT (cm)	TABLE ANGLE (Degree)	REMARK
5126	40.07	39.86	54	-13.93	31.31	6.2	37.3	191	157	Average
5126	60.94	60.73	74	-13.06	31.31	6.2	37.3	191	157	Peak
5230	93.94	93.63			31.39	6.24	37.32	191	157	Average
5230	103.9	103.59			31.39	6.24	37.32	191	157	Peak
5386	38.77	38.13	54	-15.23	31.51	6.31	37.18	191	157	Average
5386	60.31	59.67	74	-13.69	31.51	6.31	37.18	191	157	Peak

REMARKS:

- Emission Level = Read Level + Antenna Factor + Cable Loss - Preamp Factor
Margin value = Emission level – Limit value
- 5230 MHz: Fundamental frequency.

EUT TEST CONDITION		MEASUREMENT DETAIL	
CHANNEL	Channel 54	FREQUENCY RANGE	1 GHz ~ 40 GHz
INPUT POWER	120 Vac, 60 Hz	DETECTOR FUNCTION	Peak (PK) Average (AV)
ENVIRONMENTAL CONDITIONS	25 deg. C, 65 % RH	TESTED BY	Gavin Wu

ANTENNA POLARITY & TEST DISTANCE: HORIZONTAL AT 3 M										
FREQ. (MHz)	EMISSION LEVEL (dBuV/m)	READ LEVEL (dBuV)	LIMIT (dBuV/m)	MARGIN (dB)	ANTENNA FACTOR (dB/m)	CABLE LOSS (dB)	PREAMP FACTOR (dB)	ANTENNA HEIGHT (cm)	TABLE ANGLE (Degree)	REMARK
5130	38.83	38.62	54	-15.17	31.31	6.2	37.3	188	179	Average
5130	59.65	59.44	74	-14.35	31.31	6.2	37.3	188	179	Peak
5270	92.15	91.76			31.41	6.25	37.27	188	179	Average
5270	101.48	101.09			31.41	6.25	37.27	188	179	Peak
5444	38.86	38.1	54	-15.14	31.55	6.34	37.13	188	179	Average
5444	59.92	59.16	74	-14.08	31.55	6.34	37.13	188	179	Peak

ANTENNA POLARITY & TEST DISTANCE: VERTICAL AT 3 M										
FREQ. (MHz)	EMISSION LEVEL (dBuV/m)	READ LEVEL (dBuV)	LIMIT (dBuV/m)	MARGIN (dB)	ANTENNA FACTOR (dB/m)	CABLE LOSS (dB)	PREAMP FACTOR (dB)	ANTENNA HEIGHT (cm)	TABLE ANGLE (Degree)	REMARK
5108	38.52	38.32	54	-15.48	31.29	6.19	37.28	120	118	Average
5108	59.64	59.44	74	-14.36	31.29	6.19	37.28	120	118	Peak
5270	93.07	92.68			31.41	6.25	37.27	120	118	Average
5270	102.39	102			31.41	6.25	37.27	120	118	Peak
5456	39.12	38.3	54	-14.88	31.56	6.34	37.08	120	118	Average
5456	61.32	60.5	74	-12.68	31.56	6.34	37.08	120	118	Peak

REMARKS:

- Emission Level = Read Level + Antenna Factor + Cable Loss - Preamp Factor
Margin value = Emission level – Limit value
- 5270 MHz: Fundamental frequency.

EUT TEST CONDITION		MEASUREMENT DETAIL	
CHANNEL	Channel 62	FREQUENCY RANGE	1 GHz ~ 40 GHz
INPUT POWER	120 Vac, 60 Hz	DETECTOR FUNCTION	Peak (PK) Average (AV)
ENVIRONMENTAL CONDITIONS	25 deg. C, 65 % RH	TESTED BY	Gavin Wu

ANTENNA POLARITY & TEST DISTANCE: HORIZONTAL AT 3 M										
FREQ. (MHz)	EMISSION LEVEL (dBuV/m)	READ LEVEL (dBuV)	LIMIT (dBuV/m)	MARGIN (dB)	ANTENNA FACTOR (dB/m)	CABLE LOSS (dB)	PREAMP FACTOR (dB)	ANTENNA HEIGHT (cm)	TABLE ANGLE (Degree)	REMARK
5044	38.29	38.15	54	-15.71	31.24	6.15	37.25	184	187	Average
5044	60.46	60.32	74	-13.54	31.24	6.15	37.25	184	187	Peak
5310	88.62	88.09			31.45	6.27	37.19	184	187	Average
5310	98.12	97.59			31.45	6.27	37.19	184	187	Peak
5350	46.49	45.9	54	-7.51	31.48	6.29	37.18	184	187	Average
5350	67.81	67.22	74	-6.19	31.48	6.29	37.18	184	187	Peak
ANTENNA POLARITY & TEST DISTANCE: VERTICAL AT 3 M										
FREQ. (MHz)	EMISSION LEVEL (dBuV/m)	READ LEVEL (dBuV)	LIMIT (dBuV/m)	MARGIN (dB)	ANTENNA FACTOR (dB/m)	CABLE LOSS (dB)	PREAMP FACTOR (dB)	ANTENNA HEIGHT (cm)	TABLE ANGLE (Degree)	REMARK
5096	38.32	38.13	54	-15.68	31.28	6.19	37.28	119	129	Average
5096	59.98	59.79	74	-14.02	31.28	6.19	37.28	119	129	Peak
5310	90.47	89.94			31.45	6.27	37.19	119	129	Average
5310	99.81	99.28			31.45	6.27	37.19	119	129	Peak
5348	48.43	47.84	54	-5.57	31.48	6.29	37.18	119	129	Average
5348	69.17	68.58	74	-4.83	31.48	6.29	37.18	119	129	Peak

REMARKS:

- Emission Level = Read Level + Antenna Factor + Cable Loss - Preamp Factor
Margin value = Emission level – Limit value
- 5310 MHz: Fundamental frequency.

EUT TEST CONDITION		MEASUREMENT DETAIL	
CHANNEL	Channel 102	FREQUENCY RANGE	1 GHz ~ 40 GHz
INPUT POWER	120 Vac, 60 Hz	DETECTOR FUNCTION	Peak (PK) Average (AV)
ENVIRONMENTAL CONDITIONS	25 deg. C, 65 % RH	TESTED BY	Gavin Wu

ANTENNA POLARITY & TEST DISTANCE: HORIZONTAL AT 3 M										
FREQ. (MHz)	EMISSION LEVEL (dBuV/m)	READ LEVEL (dBuV)	LIMIT (dBuV/m)	MARGIN (dB)	ANTENNA FACTOR (dB/m)	CABLE LOSS (dB)	PREAMP FACTOR (dB)	ANTENNA HEIGHT (cm)	TABLE ANGLE (Degree)	REMARK
5456	43.78	42.96	54	-10.22	31.56	6.34	37.08	197	188	Average
5456	60.7	59.88	74	-13.3	31.56	6.34	37.08	197	188	Peak
5470	64	63.17	68.2	-4.2	31.57	6.34	37.08	197	188	Peak
5510	86.08	85.18			31.6	6.36	37.06	197	188	Average
5510	96.96	96.06			31.6	6.36	37.06	197	188	Peak
5725	59.52	58.24	68.2	-8.68	31.96	6.75	37.43	197	188	Peak
ANTENNA POLARITY & TEST DISTANCE: VERTICAL AT 3 M										
FREQ. (MHz)	EMISSION LEVEL (dBuV/m)	READ LEVEL (dBuV)	LIMIT (dBuV/m)	MARGIN (dB)	ANTENNA FACTOR (dB/m)	CABLE LOSS (dB)	PREAMP FACTOR (dB)	ANTENNA HEIGHT (cm)	TABLE ANGLE (Degree)	REMARK
5460	47.13	46.31	54	-6.87	31.56	6.34	37.08	190	141	Average
5460	64.39	63.57	74	-9.61	31.56	6.34	37.08	190	141	Peak
5470	66.13	65.3	68.2	-2.07	31.57	6.34	37.08	190	141	Peak
5510	90.02	89.12			31.6	6.36	37.06	190	141	Average
5510	100.96	100.06			31.6	6.36	37.06	190	141	Peak
5725	61.89	60.61	68.2	-6.31	31.96	6.75	37.43	190	141	Peak

REMARKS:

- Emission Level = Read Level + Antenna Factor + Cable Loss - Preamp Factor
Margin value = Emission level – Limit value
- 5510 MHz: Fundamental frequency.
- 5470 MHz & 5725 MHz: Out of restricted band



A D T

EUT TEST CONDITION		MEASUREMENT DETAIL	
CHANNEL	Channel 110	FREQUENCY RANGE	1 GHz ~ 40 GHz
INPUT POWER	120 Vac, 60 Hz	DETECTOR FUNCTION	Peak (PK) Average (AV)
ENVIRONMENTAL CONDITIONS	25 deg. C, 65 % RH	TESTED BY	Gavin Wu

ANTENNA POLARITY & TEST DISTANCE: HORIZONTAL AT 3 M										
FREQ. (MHz)	EMISSION LEVEL (dBuV/m)	READ LEVEL (dBuV)	LIMIT (dBuV/m)	MARGIN (dB)	ANTENNA FACTOR (dB/m)	CABLE LOSS (dB)	PREAMP FACTOR (dB)	ANTENNA HEIGHT (cm)	TABLE ANGLE (Degree)	REMARK
5422	39.01	38.34	54	-14.99	31.53	6.32	37.18	205	187	Average
5422	59.81	59.14	74	-14.19	31.53	6.32	37.18	205	187	Peak
5470	58.47	57.64	68.2	-9.73	31.57	6.34	37.08	205	187	Peak
5550	86.74	85.73			31.68	6.42	37.09	205	187	Average
5550	96.02	95.01			31.68	6.42	37.09	205	187	Peak
5725	59.01	57.73	68.2	-9.19	31.96	6.75	37.43	205	187	Peak

ANTENNA POLARITY & TEST DISTANCE: VERTICAL AT 3 M										
FREQ. (MHz)	EMISSION LEVEL (dBuV/m)	READ LEVEL (dBuV)	LIMIT (dBuV/m)	MARGIN (dB)	ANTENNA FACTOR (dB/m)	CABLE LOSS (dB)	PREAMP FACTOR (dB)	ANTENNA HEIGHT (cm)	TABLE ANGLE (Degree)	REMARK
5440	39.71	38.95	54	-14.29	31.55	6.34	37.13	197	139	Average
5440	60.6	59.84	74	-13.4	31.55	6.34	37.13	197	139	Peak
5470	59.56	58.73	68.2	-8.64	31.57	6.34	37.08	197	139	Peak
5550	90.75	89.74			31.68	6.42	37.09	197	139	Average
5550	100.17	99.16			31.68	6.42	37.09	197	139	Peak
5725	59.43	58.15	68.2	-8.77	31.96	6.75	37.43	197	139	Peak

REMARKS:

1. Emission Level = Read Level + Antenna Factor + Cable Loss - Preamp Factor
Margin value = Emission level – Limit value
2. 5550 MHz: Fundamental frequency.
3. 5470 MHz & 5725 MHz: Out of restricted band



A D T

EUT TEST CONDITION		MEASUREMENT DETAIL	
CHANNEL	Channel 134	FREQUENCY RANGE	1 GHz ~ 40 GHz
INPUT POWER	120 Vac, 60 Hz	DETECTOR FUNCTION	Peak (PK) Average (AV)
ENVIRONMENTAL CONDITIONS	25 deg. C, 65 % RH	TESTED BY	Gavin Wu

ANTENNA POLARITY & TEST DISTANCE: HORIZONTAL AT 3 M										
FREQ. (MHz)	EMISSION LEVEL (dBuV/m)	READ LEVEL (dBuV)	LIMIT (dBuV/m)	MARGIN (dB)	ANTENNA FACTOR (dB/m)	CABLE LOSS (dB)	PREAMP FACTOR (dB)	ANTENNA HEIGHT (cm)	TABLE ANGLE (Degree)	REMARK
5366	38.52	37.9	54	-15.48	31.49	6.31	37.18	213	189	Average
5366	59.62	59	74	-14.38	31.49	6.31	37.18	213	189	Peak
5470	56.15	55.32	68.2	-12.05	31.57	6.34	37.08	213	189	Peak
5670	88.32	87.16			31.88	6.62	37.34	213	189	Average
5670	97.67	96.51			31.88	6.62	37.34	213	189	Peak
5725	58.11	56.83	68.2	-10.09	31.96	6.75	37.43	213	189	Peak

ANTENNA POLARITY & TEST DISTANCE: VERTICAL AT 3 M										
FREQ. (MHz)	EMISSION LEVEL (dBuV/m)	READ LEVEL (dBuV)	LIMIT (dBuV/m)	MARGIN (dB)	ANTENNA FACTOR (dB/m)	CABLE LOSS (dB)	PREAMP FACTOR (dB)	ANTENNA HEIGHT (cm)	TABLE ANGLE (Degree)	REMARK
5378	39.1	38.46	54	-14.9	31.51	6.31	37.18	210	139	Average
5378	61.07	60.43	74	-12.93	31.51	6.31	37.18	210	139	Peak
5470	58.78	57.95	68.2	-9.42	31.57	6.34	37.08	210	139	Peak
5670	90.53	89.37			31.88	6.62	37.34	210	139	Average
5670	100.5	99.34			31.88	6.62	37.34	210	139	Peak
5725	60.11	58.83	68.2	-8.09	31.96	6.75	37.43	210	139	Peak

REMARKS:

- Emission Level = Read Level + Antenna Factor + Cable Loss - Preamp Factor
Margin value = Emission level – Limit value
- 5670 MHz: Fundamental frequency.
- 5470 MHz & 5725 MHz: Out of restricted band



A D T

EUT TEST CONDITION		MEASUREMENT DETAIL	
CHANNEL	Channel 151	FREQUENCY RANGE	1 GHz ~ 40 GHz
INPUT POWER	120 Vac, 60 Hz	DETECTOR FUNCTION	Peak (PK) Average (AV)
ENVIRONMENTAL CONDITIONS	25 deg. C, 65 % RH	TESTED BY	Gavin Wu

ANTENNA POLARITY & TEST DISTANCE: HORIZONTAL AT 3 M										
FREQ. (MHz)	EMISSION LEVEL (dBuV/m)	READ LEVEL (dBuV)	LIMIT (dBuV/m)	MARGIN (dB)	ANTENNA FACTOR (dB/m)	CABLE LOSS (dB)	PREAMP FACTOR (dB)	ANTENNA HEIGHT (cm)	TABLE ANGLE (Degree)	REMARK
5714	59.6	58.41	68.3	-8.7	31.93	6.69	37.43	182	174	Peak
5725	60.41	59.13	78.3	-17.89	31.96	6.75	37.43	182	174	Peak
5755	92.98	91.63			32.07	6.82	37.54	182	174	Average
5755	102.91	101.56			32.07	6.82	37.54	182	174	Peak
5850	63.24	61.72	78.3	-15.06	32.15	6.88	37.51	182	174	Peak
5861	60.34	58.71	68.3	-7.96	32.18	6.95	37.5	182	174	Peak
ANTENNA POLARITY & TEST DISTANCE: VERTICAL AT 3 M										
FREQ. (MHz)	EMISSION LEVEL (dBuV/m)	READ LEVEL (dBuV)	LIMIT (dBuV/m)	MARGIN (dB)	ANTENNA FACTOR (dB/m)	CABLE LOSS (dB)	PREAMP FACTOR (dB)	ANTENNA HEIGHT (cm)	TABLE ANGLE (Degree)	REMARK
5714	60.8	59.61	68.3	-7.5	31.93	6.69	37.43	158	128	Peak
5725	61.81	60.53	78.3	-16.49	31.96	6.75	37.43	158	128	Peak
5755	88.18	86.83			32.07	6.82	37.54	158	128	Average
5755	97.66	96.31			32.07	6.82	37.54	158	128	Peak
5850	59.89	58.37	78.3	-18.41	32.15	6.88	37.51	158	128	Peak
5861	60.18	58.55	68.3	-8.12	32.18	6.95	37.5	158	128	Peak

REMARKS:

- Emission Level = Read Level + Antenna Factor + Cable Loss - Preamp Factor
Margin value = Emission level – Limit value
- 5755 MHz: Fundamental frequency.
- 5714 MHz & 5725 MHz & 5850 MHz & 5861 MHz: Out of restricted band



EUT TEST CONDITION		MEASUREMENT DETAIL	
CHANNEL	Channel 159	FREQUENCY RANGE	1 GHz ~ 40 GHz
INPUT POWER	120 Vac, 60 Hz	DETECTOR FUNCTION	Peak (PK) Average (AV)
ENVIRONMENTAL CONDITIONS	25 deg. C, 65 % RH	TESTED BY	Gavin Wu

ANTENNA POLARITY & TEST DISTANCE: HORIZONTAL AT 3 M										
FREQ. (MHz)	EMISSION LEVEL (dBuV/m)	READ LEVEL (dBuV)	LIMIT (dBuV/m)	MARGIN (dB)	ANTENNA FACTOR (dB/m)	CABLE LOSS (dB)	PREAMP FACTOR (dB)	ANTENNA HEIGHT (cm)	TABLE ANGLE (Degree)	REMARK
5714	59.64	58.45	68.2	-8.56	31.93	6.69	37.43	200	174	Peak
5725	60.81	59.53	78.2	-17.39	31.96	6.75	37.43	200	174	Peak
5795	93	91.65			32.07	6.82	37.54	200	174	Average
5795	102.47	101.12			32.07	6.82	37.54	200	174	Peak
5850	65.9	64.38	78.2	-12.3	32.15	6.88	37.51	200	174	Peak
5861	61.91	60.28	68.2	-6.29	32.18	6.95	37.5	200	174	Peak
ANTENNA POLARITY & TEST DISTANCE: VERTICAL AT 3 M										
FREQ. (MHz)	EMISSION LEVEL (dBuV/m)	READ LEVEL (dBuV)	LIMIT (dBuV/m)	MARGIN (dB)	ANTENNA FACTOR (dB/m)	CABLE LOSS (dB)	PREAMP FACTOR (dB)	ANTENNA HEIGHT (cm)	TABLE ANGLE (Degree)	REMARK
5714	59.61	58.42	68.2	-8.59	31.93	6.69	37.43	123	128	Peak
5725	59.71	58.43	78.2	-18.49	31.96	6.75	37.43	123	128	Peak
5795	88.11	86.76			32.07	6.82	37.54	123	128	Average
5795	97.4	96.05			32.07	6.82	37.54	123	128	Peak
5850	62.18	60.66	78.2	-16.02	32.15	6.88	37.51	123	128	Peak
5861	60.67	59.04	68.2	-7.53	32.18	6.95	37.5	123	128	Peak

REMARKS:

- Emission Level = Read Level + Antenna Factor + Cable Loss - Preamp Factor
Margin value = Emission level – Limit value
- 5795 MHz: Fundamental frequency.
- 5714 MHz & 5725 MHz & 5850 MHz & 5861 MHz: Out of restricted band

802.11ac (VHT80)

EUT TEST CONDITION		MEASUREMENT DETAIL	
CHANNEL	Channel 42	FREQUENCY RANGE	1 GHz ~ 40 GHz
INPUT POWER	120 Vac, 60 Hz	DETECTOR FUNCTION	Peak (PK) Average (AV)
ENVIRONMENTAL CONDITIONS	25 deg. C, 65 % RH	TESTED BY	Gavin Wu

ANTENNA POLARITY & TEST DISTANCE: HORIZONTAL AT 3 M

FREQ. (MHz)	EMISSION LEVEL (dBuV/m)	READ LEVEL (dBuV)	LIMIT (dBuV/m)	MARGIN (dB)	ANTENNA FACTOR (dB/m)	CABLE LOSS (dB)	PREAMP FACTOR (dB)	ANTENNA HEIGHT (cm)	TABLE ANGLE (Degree)	REMARK
5132	40.46	40.25	54	-13.54	31.31	6.2	37.3	212	200	Average
5132	60.45	60.24	74	-13.55	31.31	6.2	37.3	212	200	Peak
5210	79.47	79.22			31.37	6.24	37.36	212	200	Average
5210	88.85	88.6			31.37	6.24	37.36	212	200	Peak
5430	38.9	38.16	54	-15.1	31.55	6.32	37.13	212	200	Average
5430	60.5	59.76	74	-13.5	31.55	6.32	37.13	212	200	Peak

ANTENNA POLARITY & TEST DISTANCE: VERTICAL AT 3 M

FREQ. (MHz)	EMISSION LEVEL (dBuV/m)	READ LEVEL (dBuV)	LIMIT (dBuV/m)	MARGIN (dB)	ANTENNA FACTOR (dB/m)	CABLE LOSS (dB)	PREAMP FACTOR (dB)	ANTENNA HEIGHT (cm)	TABLE ANGLE (Degree)	REMARK
5142	48.34	48.12	54	-5.66	31.32	6.2	37.3	202	164	Average
5142	63.24	63.02	74	-10.76	31.32	6.2	37.3	202	164	Peak
5210	85.18	84.93			31.37	6.24	37.36	202	164	Average
5210	94.54	94.29			31.37	6.24	37.36	202	164	Peak
5432	38.75	38.01	54	-15.25	31.55	6.32	37.13	202	164	Average
5432	60.26	59.52	74	-13.74	31.55	6.32	37.13	202	164	Peak

REMARKS:

- Emission Level = Read Level + Antenna Factor + Cable Loss - Preamp Factor
Margin value = Emission level – Limit value
- 5210 MHz: Fundamental frequency.



A D T

EUT TEST CONDITION		MEASUREMENT DETAIL	
CHANNEL	Channel 58	FREQUENCY RANGE	1 GHz ~ 40 GHz
INPUT POWER	120 Vac, 60 Hz	DETECTOR FUNCTION	Peak (PK) Average (AV)
ENVIRONMENTAL CONDITIONS	25 deg. C, 65 % RH	TESTED BY	Gavin Wu

ANTENNA POLARITY & TEST DISTANCE: HORIZONTAL AT 3 M										
FREQ. (MHz)	EMISSION LEVEL (dBuV/m)	READ LEVEL (dBuV)	LIMIT (dBuV/m)	MARGIN (dB)	ANTENNA FACTOR (dB/m)	CABLE LOSS (dB)	PREAMP FACTOR (dB)	ANTENNA HEIGHT (cm)	TABLE ANGLE (Degree)	REMARK
5062	38.51	38.34	54	-15.49	31.25	6.17	37.25	225	200	Average
5062	60.75	60.58	74	-13.25	31.25	6.17	37.25	225	200	Peak
5290	85.14	84.67			31.43	6.27	37.23	225	200	Average
5290	94.5	94.03			31.43	6.27	37.23	225	200	Peak
5360	47.71	47.1	54	-6.29	31.48	6.31	37.18	225	200	Average
5360	63.55	62.94	74	-10.45	31.48	6.31	37.18	225	200	Peak

ANTENNA POLARITY & TEST DISTANCE: VERTICAL AT 3 M										
FREQ. (MHz)	EMISSION LEVEL (dBuV/m)	READ LEVEL (dBuV)	LIMIT (dBuV/m)	MARGIN (dB)	ANTENNA FACTOR (dB/m)	CABLE LOSS (dB)	PREAMP FACTOR (dB)	ANTENNA HEIGHT (cm)	TABLE ANGLE (Degree)	REMARK
5096	38.74	38.55	54	-15.26	31.28	6.19	37.28	121	147	Average
5096	59.92	59.73	74	-14.08	31.28	6.19	37.28	121	147	Peak
5290	86.22	85.75			31.43	6.27	37.23	121	147	Average
5290	95.4	94.93			31.43	6.27	37.23	121	147	Peak
5362	48.74	48.12	54	-5.26	31.49	6.31	37.18	121	147	Average
5362	64.41	63.79	74	-9.59	31.49	6.31	37.18	121	147	Peak

REMARKS:

- Emission Level = Read Level + Antenna Factor + Cable Loss - Preamp Factor
Margin value = Emission level – Limit value
- 5290 MHz: Fundamental frequency.



EUT TEST CONDITION		MEASUREMENT DETAIL	
CHANNEL	Channel 106	FREQUENCY RANGE	1 GHz ~ 40 GHz
INPUT POWER	120 Vac, 60 Hz	DETECTOR FUNCTION	Peak (PK) Average (AV)
ENVIRONMENTAL CONDITIONS	25 deg. C, 65 % RH	TESTED BY	Gavin Wu

ANTENNA POLARITY & TEST DISTANCE: HORIZONTAL AT 3 M										
FREQ. (MHz)	EMISSION LEVEL (dBuV/m)	READ LEVEL (dBuV)	LIMIT (dBuV/m)	MARGIN (dB)	ANTENNA FACTOR (dB/m)	CABLE LOSS (dB)	PREAMP FACTOR (dB)	ANTENNA HEIGHT (cm)	TABLE ANGLE (Degree)	REMARK
5458	41	40.18	54	-13	31.56	6.34	37.08	188	153	Average
5458	61.39	60.57	74	-12.61	31.56	6.34	37.08	188	153	Peak
5470	60.48	59.65	68.2	-7.72	31.57	6.34	37.08	188	153	Peak
5530	79.06	78.1			31.63	6.42	37.09	188	153	Average
5530	89.25	88.29			31.63	6.42	37.09	188	153	Peak
5725	59.93	58.65	68.2	-8.27	31.96	6.75	37.43	188	153	Peak

ANTENNA POLARITY & TEST DISTANCE: VERTICAL AT 3 M										
FREQ. (MHz)	EMISSION LEVEL (dBuV/m)	READ LEVEL (dBuV)	LIMIT (dBuV/m)	MARGIN (dB)	ANTENNA FACTOR (dB/m)	CABLE LOSS (dB)	PREAMP FACTOR (dB)	ANTENNA HEIGHT (cm)	TABLE ANGLE (Degree)	REMARK
5460	45.58	44.76	54	-8.42	31.56	6.34	37.08	205	142	Average
5460	61.8	60.98	74	-12.2	31.56	6.34	37.08	205	142	Peak
5470	59.57	58.74	68.2	-8.63	31.57	6.34	37.08	205	142	Peak
5530	82.17	81.21			31.63	6.42	37.09	205	142	Average
5530	92.38	91.42			31.63	6.42	37.09	205	142	Peak
5725	59.55	58.27	68.2	-8.65	31.96	6.75	37.43	205	142	Peak

REMARKS:

- Emission Level = Read Level + Antenna Factor + Cable Loss - Preamp Factor
Margin value = Emission level – Limit value
- 5530 MHz: Fundamental frequency.
- 5470 MHz & 5725 MHz: Out of restricted band

EUT TEST CONDITION		MEASUREMENT DETAIL	
CHANNEL	Channel 122	FREQUENCY RANGE	1 GHz ~ 40 GHz
INPUT POWER	120 Vac, 60 Hz	DETECTOR FUNCTION	Peak (PK) Average (AV)
ENVIRONMENTAL CONDITIONS	25 deg. C, 65 % RH	TESTED BY	Gavin Wu

ANTENNA POLARITY & TEST DISTANCE: HORIZONTAL AT 3 M										
FREQ. (MHz)	EMISSION LEVEL (dBuV/m)	READ LEVEL (dBuV)	LIMIT (dBuV/m)	MARGIN (dB)	ANTENNA FACTOR (dB/m)	CABLE LOSS (dB)	PREAMP FACTOR (dB)	ANTENNA HEIGHT (cm)	TABLE ANGLE (Degree)	REMARK
5374	38.37	37.75	54	-15.63	31.49	6.31	37.18	195	156	Average
5374	59.53	58.91	74	-14.47	31.49	6.31	37.18	195	156	Peak
5470	58.12	57.29	68.2	-10.08	31.57	6.34	37.08	195	156	Peak
5610	80.86	79.75			31.77	6.56	37.22	195	156	Average
5610	90.2	89.09			31.77	6.56	37.22	195	156	Peak
5725	59.2	57.92	68.2	-9	31.96	6.75	37.43	195	156	Peak
ANTENNA POLARITY & TEST DISTANCE: VERTICAL AT 3 M										
FREQ. (MHz)	EMISSION LEVEL (dBuV/m)	READ LEVEL (dBuV)	LIMIT (dBuV/m)	MARGIN (dB)	ANTENNA FACTOR (dB/m)	CABLE LOSS (dB)	PREAMP FACTOR (dB)	ANTENNA HEIGHT (cm)	TABLE ANGLE (Degree)	REMARK
5438	38.64	37.88	54	-15.36	31.55	6.34	37.13	196	137	Average
5438	60.86	60.1	74	-13.14	31.55	6.34	37.13	196	137	Peak
5470	58.41	57.58	68.2	-9.79	31.57	6.34	37.08	196	137	Peak
5610	84.26	83.15			31.77	6.56	37.22	196	137	Average
5610	94.21	93.1			31.77	6.56	37.22	196	137	Peak
5725	59.15	57.87	68.2	-9.05	31.96	6.75	37.43	196	137	Peak

REMARKS:

- Emission Level = Read Level + Antenna Factor + Cable Loss - Preamp Factor
Margin value = Emission level – Limit value
- 5610 MHz: Fundamental frequency.
- 5470 MHz & 5725 MHz: Out of restricted band

EUT TEST CONDITION		MEASUREMENT DETAIL	
CHANNEL	Channel 155	FREQUENCY RANGE	1 GHz ~ 40 GHz
INPUT POWER	120 Vac, 60 Hz	DETECTOR FUNCTION	Peak (PK) Average (AV)
ENVIRONMENTAL CONDITIONS	25 deg. C, 65 % RH	TESTED BY	Gavin Wu

ANTENNA POLARITY & TEST DISTANCE: HORIZONTAL AT 3 M										
FREQ. (MHz)	EMISSION LEVEL (dBuV/m)	READ LEVEL (dBuV)	LIMIT (dBuV/m)	MARGIN (dB)	ANTENNA FACTOR (dB/m)	CABLE LOSS (dB)	PREAMP FACTOR (dB)	ANTENNA HEIGHT (cm)	TABLE ANGLE (Degree)	REMARK
5714	61.83	60.64	68.2	-6.37	31.93	6.69	37.43	200	175	Peak
5725	62.49	61.21	78.2	-15.71	31.96	6.75	37.43	200	175	Peak
5775	85.01	83.65			32.04	6.82	37.5	200	175	Average
5775	94.31	92.95			32.04	6.82	37.5	200	175	Peak
5850	62.41	60.89	78.2	-15.79	32.15	6.88	37.51	200	175	Peak
5861	61.83	60.2	68.2	-6.37	32.18	6.95	37.5	200	175	Peak
ANTENNA POLARITY & TEST DISTANCE: VERTICAL AT 3 M										
FREQ. (MHz)	EMISSION LEVEL (dBuV/m)	READ LEVEL (dBuV)	LIMIT (dBuV/m)	MARGIN (dB)	ANTENNA FACTOR (dB/m)	CABLE LOSS (dB)	PREAMP FACTOR (dB)	ANTENNA HEIGHT (cm)	TABLE ANGLE (Degree)	REMARK
5714	62.09	60.9	68.2	-6.11	31.93	6.69	37.43	111	120	Peak
5725	61.66	60.38	78.2	-16.54	31.96	6.75	37.43	111	120	Peak
5775	79.65	78.29			32.04	6.82	37.5	111	120	Average
5775	89.22	87.86			32.04	6.82	37.5	111	120	Peak
5850	61.33	59.81	78.2	-16.87	32.15	6.88	37.51	111	120	Peak
5861	61.53	59.9	68.2	-6.67	32.18	6.95	37.5	111	120	Peak

REMARKS:

- Emission Level = Read Level + Antenna Factor + Cable Loss - Preamp Factor
Margin value = Emission level – Limit value
- 5775 MHz: Fundamental frequency.
- 5714 MHz & 5725 MHz & 5850 MHz & 5861 MHz: Out of restricted band

9 kHz ~ 30 MHz DATA:

The amplitude of spurious emissions attenuated more than 20 dB below the permissible value is not required to be report.

30 MHz ~ 1 GHz WORST-CASE DATA:
802.11n (HT40)

EUT TEST CONDITION		MEASUREMENT DETAIL	
CHANNEL	Channel 38	FREQUENCY RANGE	30 MHz ~ 1 GHz
INPUT POWER	120 Vac, 60 Hz	DETECTOR FUNCTION	Peak (PK) Quasi-peak (QP)
ENVIRONMENTAL CONDITIONS	25 deg. C, 65 % RH	TESTED BY	Gavin Wu

ANTENNA POLARITY & TEST DISTANCE: HORIZONTAL AT 3 M

FREQ. (MHz)	EMISSION LEVEL (dBuV/m)	READ LEVEL (dBuV)	LIMIT (dBuV/m)	MARGIN (dB)	ANTENNA FACTOR (dB/m)	CABLE LOSS (dB)	PREAMP FACTOR (dB)	ANTENNA HEIGHT (cm)	TABLE ANGLE (Degree)	REMARK
175.5	26.57	46.01	43.5	-16.93	11.19	1.16	31.79	134	153	Peak
209.45	18.4	38.91	43.5	-25.1	9.77	1.33	31.61	110	14	Peak
434.49	18.25	32.28	46	-27.75	16.02	1.96	32.01	138	127	Peak
515.97	19.87	31.65	46	-26.13	17.68	2.12	31.58	134	152	Peak
611.03	21.23	31.3	46	-24.77	19.74	2.28	32.09	107	292	Peak
683.78	24.15	32.95	46	-21.85	20.62	2.42	31.84	136	176	Peak

ANTENNA POLARITY & TEST DISTANCE: VERTICAL AT 3 M

FREQ. (MHz)	EMISSION LEVEL (dBuV/m)	READ LEVEL (dBuV)	LIMIT (dBuV/m)	MARGIN (dB)	ANTENNA FACTOR (dB/m)	CABLE LOSS (dB)	PREAMP FACTOR (dB)	ANTENNA HEIGHT (cm)	TABLE ANGLE (Degree)	REMARK
48.43	27.58	44.96	40	-12.42	13.18	0.69	31.25	127	11	Peak
192.96	26.95	47.54	43.5	-16.55	9.84	1.27	31.7	132	38	Peak
341.37	21.13	37.27	46	-24.87	13.94	1.74	31.82	122	355	Peak
614.91	21.79	31.83	46	-24.21	19.79	2.29	32.12	127	51	Peak
682.81	22.73	31.54	46	-23.27	20.61	2.42	31.84	113	66	Peak
770.11	23.88	30.8	46	-22.12	21.81	2.57	31.3	100	221	Peak

REMARKS: Emission Level = Read Level + Antenna Factor + Cable Loss - Preamp Factor

Margin value = Emission level – Limit value

802.11n (HT40)

EUT TEST CONDITION		MEASUREMENT DETAIL	
CHANNEL	Channel 62	FREQUENCY RANGE	30 MHz ~ 1 GHz
INPUT POWER	120 Vac, 60 Hz	DETECTOR FUNCTION	Peak (PK) Quasi-peak (QP)
ENVIRONMENTAL CONDITIONS	25 deg. C, 65 % RH	TESTED BY	Gavin Wu

ANTENNA POLARITY & TEST DISTANCE: HORIZONTAL AT 3 M

FREQ. (MHz)	EMISSION LEVEL (dBuV/m)	READ LEVEL (dBuV)	LIMIT (dBuV/m)	MARGIN (dB)	ANTENNA FACTOR (dB/m)	CABLE LOSS (dB)	PREAMP FACTOR (dB)	ANTENNA HEIGHT (cm)	TABLE ANGLE (Degree)	REMARK
127	29.29	48.56	43.5	-14.21	11.48	1.14	31.89	102	189	Peak
176.47	26.96	46.49	43.5	-16.54	11.1	1.17	31.8	126	296	Peak
218.18	24.78	44.97	46	-21.22	10.13	1.37	31.69	122	129	Peak
649.83	22.57	32.02	46	-23.43	20.21	2.36	32.02	126	301	Peak
700.27	24.13	32.65	46	-21.87	20.82	2.45	31.79	136	78	Peak
738.1	23.88	31.51	46	-22.12	21.35	2.52	31.5	126	114	Peak

ANTENNA POLARITY & TEST DISTANCE: VERTICAL AT 3 M

FREQ. (MHz)	EMISSION LEVEL (dBuV/m)	READ LEVEL (dBuV)	LIMIT (dBuV/m)	MARGIN (dB)	ANTENNA FACTOR (dB/m)	CABLE LOSS (dB)	PREAMP FACTOR (dB)	ANTENNA HEIGHT (cm)	TABLE ANGLE (Degree)	REMARK
42.61	24.92	41.76	40	-15.08	13.58	0.66	31.08	127	221	Peak
186.17	21.76	41.93	43.5	-21.74	10.33	1.24	31.74	133	145	Peak
210.42	20.16	40.6	43.5	-23.34	9.81	1.34	31.59	126	15	Peak
719.67	23.51	31.6	46	-22.49	21.09	2.48	31.66	101	263	Peak
757.5	24.31	31.55	46	-21.69	21.63	2.54	31.41	102	336	Peak
788.54	24.75	31.49	46	-21.25	22.07	2.6	31.41	139	17	Peak

REMARKS: Emission Level = Read Level + Antenna Factor + Cable Loss - Preamp Factor

Margin value = Emission level – Limit value

802.11n (HT20)

EUT TEST CONDITION		MEASUREMENT DETAIL	
CHANNEL	Channel 140	FREQUENCY RANGE	30 MHz ~ 1 GHz
INPUT POWER	120 Vac, 60 Hz	DETECTOR FUNCTION	Peak (PK) Quasi-peak (QP)
ENVIRONMENTAL CONDITIONS	25 deg. C, 65 % RH	TESTED BY	Gavin Wu

ANTENNA POLARITY & TEST DISTANCE: HORIZONTAL AT 3 M

FREQ. (MHz)	EMISSION LEVEL (dBuV/m)	READ LEVEL (dBuV)	LIMIT (dBuV/m)	MARGIN (dB)	ANTENNA FACTOR (dB/m)	CABLE LOSS (dB)	PREAMP FACTOR (dB)	ANTENNA HEIGHT (cm)	TABLE ANGLE (Degree)	REMARK
129.91	24.74	43.8	43.5	-18.76	11.68	1.14	31.88	104	315	Peak
218.18	23.39	43.58	46	-22.61	10.13	1.37	31.69	137	202	Peak
345.25	20.27	36.32	46	-25.73	14.03	1.75	31.83	113	137	Peak
658.56	22.26	31.54	46	-23.74	20.31	2.37	31.96	130	158	Peak
759.44	24.01	31.24	46	-21.99	21.66	2.55	31.44	103	203	Peak
795.33	25.64	32.29	46	-20.36	22.16	2.61	31.42	129	225	Peak

ANTENNA POLARITY & TEST DISTANCE: VERTICAL AT 3 M

FREQ. (MHz)	EMISSION LEVEL (dBuV/m)	READ LEVEL (dBuV)	LIMIT (dBuV/m)	MARGIN (dB)	ANTENNA FACTOR (dB/m)	CABLE LOSS (dB)	PREAMP FACTOR (dB)	ANTENNA HEIGHT (cm)	TABLE ANGLE (Degree)	REMARK
51.34	23.24	40.97	40	-16.76	12.87	0.71	31.31	132	137	Peak
189.08	20.31	40.63	43.5	-23.19	10.12	1.25	31.69	106	58	Peak
207.51	22.74	43.36	43.5	-20.76	9.69	1.33	31.64	104	321	Peak
670.2	23.08	32.03	46	-22.92	20.46	2.4	31.81	111	127	Peak
736.16	24.27	31.95	46	-21.73	21.33	2.51	31.52	132	288	Peak
753.62	24.51	31.75	46	-21.49	21.57	2.54	31.35	125	115	Peak

REMARKS: Emission Level = Read Level + Antenna Factor + Cable Loss - Preamp Factor

Margin value = Emission level – Limit value



802.11a

EUT TEST CONDITION		MEASUREMENT DETAIL	
CHANNEL	Channel 165	FREQUENCY RANGE	30 MHz ~ 1 GHz
INPUT POWER	120 Vac, 60 Hz	DETECTOR FUNCTION	Peak (PK) Quasi-peak (QP)
ENVIRONMENTAL CONDITIONS	25 deg. C, 65 % RH	TESTED BY	Gavin Wu

ANTENNA POLARITY & TEST DISTANCE: HORIZONTAL AT 3 M										
FREQ. (MHz)	EMISSION LEVEL (dBuV/m)	READ LEVEL (dBuV)	LIMIT (dBuV/m)	MARGIN (dB)	ANTENNA FACTOR (dB/m)	CABLE LOSS (dB)	PREAMP FACTOR (dB)	ANTENNA HEIGHT (cm)	TABLE ANGLE (Degree)	REMARK
124.09	25.36	44.82	43.5	-18.14	11.28	1.15	31.89	129	188	Peak
177.44	26.13	45.74	43.5	-17.37	11.01	1.19	31.81	108	51	Peak
196.84	22.73	43.62	43.5	-20.77	9.57	1.28	31.74	101	167	Peak
661.47	22.29	31.48	46	-23.71	20.35	2.38	31.92	122	281	Peak
740.04	23.78	31.36	46	-22.22	21.38	2.52	31.48	103	263	Peak
780.78	24.49	31.38	46	-21.51	21.96	2.58	31.43	109	155	Peak
ANTENNA POLARITY & TEST DISTANCE: VERTICAL AT 3 M										
FREQ. (MHz)	EMISSION LEVEL (dBuV/m)	READ LEVEL (dBuV)	LIMIT (dBuV/m)	MARGIN (dB)	ANTENNA FACTOR (dB/m)	CABLE LOSS (dB)	PREAMP FACTOR (dB)	ANTENNA HEIGHT (cm)	TABLE ANGLE (Degree)	REMARK
49.4	25.48	42.98	40	-14.52	13.08	0.7	31.28	114	329	Peak
195.87	25.23	46.04	43.5	-18.27	9.64	1.28	31.73	131	287	Peak
229.82	22.4	42.22	46	-23.6	10.62	1.42	31.86	123	333	Peak
674.08	23.01	31.92	46	-22.99	20.5	2.41	31.82	124	20	Peak
738.1	23.03	30.66	46	-22.97	21.35	2.52	31.5	105	321	Peak
777.87	24.54	31.44	46	-21.46	21.92	2.58	31.4	104	127	Peak

REMARKS: Emission Level = Read Level + Antenna Factor + Cable Loss - Preamp Factor

Margin value = Emission level – Limit value

Mode B
ABOVE 1 GHz DATA :
802.11n (HT20)

EUT TEST CONDITION		MEASUREMENT DETAIL	
CHANNEL	Channel 36	FREQUENCY RANGE	1 GHz ~ 40 GHz
INPUT POWER	120 Vac, 60 Hz	DETECTOR FUNCTION	Peak (PK) Average (AV)
ENVIRONMENTAL CONDITIONS	25 deg. C, 65 % RH	TESTED BY	Gavin Wu

ANTENNA POLARITY & TEST DISTANCE: HORIZONTAL AT 3 M										
FREQ. (MHz)	EMISSION LEVEL (dBuV/m)	READ LEVEL (dBuV)	LIMIT (dBuV/m)	MARGIN (dB)	ANTENNA FACTOR (dB/m)	CABLE LOSS (dB)	PREAMP FACTOR (dB)	ANTENNA HEIGHT (cm)	TABLE ANGLE (Degree)	REMARK
5128	41.51	41.3	54	-12.49	31.31	6.2	37.3	192	165	Average
5128	60.29	60.08	74	-13.71	31.31	6.2	37.3	192	165	Peak
5180	95.12	94.89			31.35	6.22	37.34	192	165	Average
5180	103.97	103.74			31.35	6.22	37.34	192	165	Peak
5350	38.25	37.66	54	-15.75	31.48	6.29	37.18	192	165	Average
5350	60.58	59.99	74	-13.42	31.48	6.29	37.18	192	165	Peak

ANTENNA POLARITY & TEST DISTANCE: VERTICAL AT 3 M										
FREQ. (MHz)	EMISSION LEVEL (dBuV/m)	READ LEVEL (dBuV)	LIMIT (dBuV/m)	MARGIN (dB)	ANTENNA FACTOR (dB/m)	CABLE LOSS (dB)	PREAMP FACTOR (dB)	ANTENNA HEIGHT (cm)	TABLE ANGLE (Degree)	REMARK
5142	43.37	43.15	54	-10.63	31.32	6.2	37.3	196	155	Average
5142	60.56	60.34	74	-13.44	31.32	6.2	37.3	196	155	Peak
5180	97.19	96.96			31.35	6.22	37.34	196	155	Average
5180	106.34	106.11			31.35	6.22	37.34	196	155	Peak
5456	38.67	37.85	54	-15.33	31.56	6.34	37.08	196	155	Average
5456	61.29	60.47	74	-12.71	31.56	6.34	37.08	196	155	Peak

REMARKS:

- Emission Level = Read Level + Antenna Factor + Cable Loss - Preamp Factor
Margin value = Emission level – Limit value
- 5180 MHz: Fundamental frequency.



A D T

EUT TEST CONDITION		MEASUREMENT DETAIL	
CHANNEL	Channel 44	FREQUENCY RANGE	1 GHz ~ 40 GHz
INPUT POWER	120 Vac, 60 Hz	DETECTOR FUNCTION	Peak (PK) Average (AV)
ENVIRONMENTAL CONDITIONS	25 deg. C, 65 % RH	TESTED BY	Gavin Wu

ANTENNA POLARITY & TEST DISTANCE: HORIZONTAL AT 3 M										
FREQ. (MHz)	EMISSION LEVEL (dBuV/m)	READ LEVEL (dBuV)	LIMIT (dBuV/m)	MARGIN (dB)	ANTENNA FACTOR (dB/m)	CABLE LOSS (dB)	PREAMP FACTOR (dB)	ANTENNA HEIGHT (cm)	TABLE ANGLE (Degree)	REMARK
5032	38.47	38.33	54	-15.53	31.23	6.15	37.24	192	166	Average
5032	59.35	59.21	74	-14.65	31.23	6.15	37.24	192	166	Peak
5220	95.09	94.84			31.37	6.24	37.36	192	166	Average
5220	104.09	103.84			31.37	6.24	37.36	192	166	Peak
5456	38.36	37.54	54	-15.64	31.56	6.34	37.08	192	166	Average
5456	60.2	59.38	74	-13.8	31.56	6.34	37.08	192	166	Peak

ANTENNA POLARITY & TEST DISTANCE: VERTICAL AT 3 M										
FREQ. (MHz)	EMISSION LEVEL (dBuV/m)	READ LEVEL (dBuV)	LIMIT (dBuV/m)	MARGIN (dB)	ANTENNA FACTOR (dB/m)	CABLE LOSS (dB)	PREAMP FACTOR (dB)	ANTENNA HEIGHT (cm)	TABLE ANGLE (Degree)	REMARK
5150	39.19	38.99	54	-14.81	31.32	6.2	37.32	194	154	Average
5150	60.59	60.39	74	-13.41	31.32	6.2	37.32	194	154	Peak
5220	97.34	97.09			31.37	6.24	37.36	194	154	Average
5220	106.27	106.02			31.37	6.24	37.36	194	154	Peak
5402	38.47	37.81	54	-15.53	31.52	6.32	37.18	194	154	Average
5402	59.94	59.28	74	-14.06	31.52	6.32	37.18	194	154	Peak

REMARKS:

1. Emission Level = Read Level + Antenna Factor + Cable Loss - Preamp Factor
Margin value = Emission level – Limit value
2. 5220 MHz: Fundamental frequency.



A D T

EUT TEST CONDITION		MEASUREMENT DETAIL	
CHANNEL	Channel 48	FREQUENCY RANGE	1 GHz ~ 40 GHz
INPUT POWER	120 Vac, 60 Hz	DETECTOR FUNCTION	Peak (PK) Average (AV)
ENVIRONMENTAL CONDITIONS	25 deg. C, 65 % RH	TESTED BY	Gavin Wu

ANTENNA POLARITY & TEST DISTANCE: HORIZONTAL AT 3 M										
FREQ. (MHz)	EMISSION LEVEL (dBuV/m)	READ LEVEL (dBuV)	LIMIT (dBuV/m)	MARGIN (dB)	ANTENNA FACTOR (dB/m)	CABLE LOSS (dB)	PREAMP FACTOR (dB)	ANTENNA HEIGHT (cm)	TABLE ANGLE (Degree)	REMARK
5110	38.48	38.28	54	-15.52	31.29	6.19	37.28	197	172	Average
5110	60.03	59.83	74	-13.97	31.29	6.19	37.28	197	172	Peak
5240	95.09	94.77			31.39	6.25	37.32	197	172	Average
5240	104.29	103.97			31.39	6.25	37.32	197	172	Peak
5420	38.45	37.78	54	-15.55	31.53	6.32	37.18	197	172	Average
5420	60.11	59.44	74	-13.89	31.53	6.32	37.18	197	172	Peak

ANTENNA POLARITY & TEST DISTANCE: VERTICAL AT 3 M										
FREQ. (MHz)	EMISSION LEVEL (dBuV/m)	READ LEVEL (dBuV)	LIMIT (dBuV/m)	MARGIN (dB)	ANTENNA FACTOR (dB/m)	CABLE LOSS (dB)	PREAMP FACTOR (dB)	ANTENNA HEIGHT (cm)	TABLE ANGLE (Degree)	REMARK
5088	38.52	38.33	54	-15.48	31.27	6.19	37.27	194	147	Average
5088	61.11	60.92	74	-12.89	31.27	6.19	37.27	194	147	Peak
5240	97.26	96.94			31.39	6.25	37.32	194	147	Average
5240	106.36	106.04			31.39	6.25	37.32	194	147	Peak
5392	38.57	37.93	54	-15.43	31.51	6.31	37.18	194	147	Average
5392	61.24	60.6	74	-12.76	31.51	6.31	37.18	194	147	Peak

REMARKS:

1. Emission Level = Read Level + Antenna Factor + Cable Loss - Preamp Factor
Margin value = Emission level – Limit value
2. 5240 MHz: Fundamental frequency.



A D T

EUT TEST CONDITION		MEASUREMENT DETAIL	
CHANNEL	Channel 52	FREQUENCY RANGE	1 GHz ~ 40 GHz
INPUT POWER	120 Vac, 60 Hz	DETECTOR FUNCTION	Peak (PK) Average (AV)
ENVIRONMENTAL CONDITIONS	25 deg. C, 65 % RH	TESTED BY	Gavin Wu

ANTENNA POLARITY & TEST DISTANCE: HORIZONTAL AT 3 M										
FREQ. (MHz)	EMISSION LEVEL (dBuV/m)	READ LEVEL (dBuV)	LIMIT (dBuV/m)	MARGIN (dB)	ANTENNA FACTOR (dB/m)	CABLE LOSS (dB)	PREAMP FACTOR (dB)	ANTENNA HEIGHT (cm)	TABLE ANGLE (Degree)	REMARK
5048	37.95	37.81	54	-16.05	31.24	6.15	37.25	200	169	Average
5048	59.96	59.82	74	-14.04	31.24	6.15	37.25	200	169	Peak
5260	94.65	94.26			31.41	6.25	37.27	200	169	Average
5260	103.75	103.36			31.41	6.25	37.27	200	169	Peak
5452	38.35	37.53	54	-15.65	31.56	6.34	37.08	200	169	Average
5452	60.25	59.43	74	-13.75	31.56	6.34	37.08	200	169	Peak

ANTENNA POLARITY & TEST DISTANCE: VERTICAL AT 3 M										
FREQ. (MHz)	EMISSION LEVEL (dBuV/m)	READ LEVEL (dBuV)	LIMIT (dBuV/m)	MARGIN (dB)	ANTENNA FACTOR (dB/m)	CABLE LOSS (dB)	PREAMP FACTOR (dB)	ANTENNA HEIGHT (cm)	TABLE ANGLE (Degree)	REMARK
5034	38.35	38.21	54	-15.65	31.23	6.15	37.24	190	136	Average
5034	60.19	60.05	74	-13.81	31.23	6.15	37.24	190	136	Peak
5260	95.97	95.58			31.41	6.25	37.27	190	136	Average
5260	105.08	104.69			31.41	6.25	37.27	190	136	Peak
5378	38.51	37.87	54	-15.49	31.51	6.31	37.18	190	136	Average
5378	60.29	59.65	74	-13.71	31.51	6.31	37.18	190	136	Peak

REMARKS:

1. Emission Level = Read Level + Antenna Factor + Cable Loss - Preamp Factor
Margin value = Emission level – Limit value
2. 5260 MHz: Fundamental frequency.



A D T

EUT TEST CONDITION		MEASUREMENT DETAIL	
CHANNEL	Channel 60	FREQUENCY RANGE	1 GHz ~ 40 GHz
INPUT POWER	120 Vac, 60 Hz	DETECTOR FUNCTION	Peak (PK) Average (AV)
ENVIRONMENTAL CONDITIONS	25 deg. C, 65 % RH	TESTED BY	Gavin Wu

ANTENNA POLARITY & TEST DISTANCE: HORIZONTAL AT 3 M										
FREQ. (MHz)	EMISSION LEVEL (dBuV/m)	READ LEVEL (dBuV)	LIMIT (dBuV/m)	MARGIN (dB)	ANTENNA FACTOR (dB/m)	CABLE LOSS (dB)	PREAMP FACTOR (dB)	ANTENNA HEIGHT (cm)	TABLE ANGLE (Degree)	REMARK
5118	38.68	38.48	54	-15.32	31.29	6.19	37.28	187	174	Average
5118	60.97	60.77	74	-13.03	31.29	6.19	37.28	187	174	Peak
5300	94.72	94.2			31.44	6.27	37.19	187	174	Average
5300	103.92	103.4			31.44	6.27	37.19	187	174	Peak
5386	39.68	39.04	54	-14.32	31.51	6.31	37.18	187	174	Average
5386	60.31	59.67	74	-13.69	31.51	6.31	37.18	187	174	Peak

ANTENNA POLARITY & TEST DISTANCE: VERTICAL AT 3 M										
FREQ. (MHz)	EMISSION LEVEL (dBuV/m)	READ LEVEL (dBuV)	LIMIT (dBuV/m)	MARGIN (dB)	ANTENNA FACTOR (dB/m)	CABLE LOSS (dB)	PREAMP FACTOR (dB)	ANTENNA HEIGHT (cm)	TABLE ANGLE (Degree)	REMARK
5064	38.72	38.55	54	-15.28	31.25	6.17	37.25	178	146	Average
5064	60.85	60.68	74	-13.15	31.25	6.17	37.25	178	146	Peak
5300	96.27	95.75			31.44	6.27	37.19	178	146	Average
5300	105.24	104.72			31.44	6.27	37.19	178	146	Peak
5438	39.79	39.03	54	-14.21	31.55	6.34	37.13	178	146	Average
5438	60.98	60.22	74	-13.02	31.55	6.34	37.13	178	146	Peak

REMARKS:

- Emission Level = Read Level + Antenna Factor + Cable Loss - Preamp Factor
Margin value = Emission level – Limit value
- 5300 MHz: Fundamental frequency.

EUT TEST CONDITION		MEASUREMENT DETAIL	
CHANNEL	Channel 64	FREQUENCY RANGE	1 GHz ~ 40 GHz
INPUT POWER	120 Vac, 60 Hz	DETECTOR FUNCTION	Peak (PK) Average (AV)
ENVIRONMENTAL CONDITIONS	25 deg. C, 65 % RH	TESTED BY	Gavin Wu

ANTENNA POLARITY & TEST DISTANCE: HORIZONTAL AT 3 M										
FREQ. (MHz)	EMISSION LEVEL (dBuV/m)	READ LEVEL (dBuV)	LIMIT (dBuV/m)	MARGIN (dB)	ANTENNA FACTOR (dB/m)	CABLE LOSS (dB)	PREAMP FACTOR (dB)	ANTENNA HEIGHT (cm)	TABLE ANGLE (Degree)	REMARK
5086	38.26	38.09	54	-15.74	31.27	6.17	37.27	188	166	Average
5086	60.27	60.1	74	-13.73	31.27	6.17	37.27	188	166	Peak
5320	94.95	94.4			31.45	6.29	37.19	188	166	Average
5320	103.9	103.35			31.45	6.29	37.19	188	166	Peak
5352	40.53	39.94	54	-13.47	31.48	6.29	37.18	188	166	Average
5352	61.77	61.18	74	-12.23	31.48	6.29	37.18	188	166	Peak

ANTENNA POLARITY & TEST DISTANCE: VERTICAL AT 3 M										
FREQ. (MHz)	EMISSION LEVEL (dBuV/m)	READ LEVEL (dBuV)	LIMIT (dBuV/m)	MARGIN (dB)	ANTENNA FACTOR (dB/m)	CABLE LOSS (dB)	PREAMP FACTOR (dB)	ANTENNA HEIGHT (cm)	TABLE ANGLE (Degree)	REMARK
5020	38.39	38.27	54	-15.61	31.21	6.15	37.24	199	144	Average
5020	59.48	59.36	74	-14.52	31.21	6.15	37.24	199	144	Peak
5320	95.81	95.26			31.45	6.29	37.19	199	144	Average
5320	105.07	104.52			31.45	6.29	37.19	199	144	Peak
5350	41.8	41.21	54	-12.2	31.48	6.29	37.18	199	144	Average
5350	61.26	60.67	74	-12.74	31.48	6.29	37.18	199	144	Peak

REMARKS:

- Emission Level = Read Level + Antenna Factor + Cable Loss - Preamp Factor
Margin value = Emission level – Limit value
- 5320 MHz: Fundamental frequency.

EUT TEST CONDITION		MEASUREMENT DETAIL	
CHANNEL	Channel 100	FREQUENCY RANGE	1 GHz ~ 40 GHz
INPUT POWER	120 Vac, 60 Hz	DETECTOR FUNCTION	Peak (PK) Average (AV)
ENVIRONMENTAL CONDITIONS	25 deg. C, 65 % RH	TESTED BY	Gavin Wu

ANTENNA POLARITY & TEST DISTANCE: HORIZONTAL AT 3 M										
FREQ. (MHz)	EMISSION LEVEL (dBuV/m)	READ LEVEL (dBuV)	LIMIT (dBuV/m)	MARGIN (dB)	ANTENNA FACTOR (dB/m)	CABLE LOSS (dB)	PREAMP FACTOR (dB)	ANTENNA HEIGHT (cm)	TABLE ANGLE (Degree)	REMARK
5420	39.15	38.48	54	-14.85	31.53	6.32	37.18	190	166	Average
5420	59.66	58.99	74	-14.34	31.53	6.32	37.18	190	166	Peak
5470	57.53	56.7	68.2	-10.67	31.57	6.34	37.08	190	166	Peak
5500	94.03	93.1			31.6	6.36	37.03	190	166	Average
5500	103.15	102.22			31.6	6.36	37.03	190	166	Peak
5725	58.62	57.34	68.2	-9.58	31.96	6.75	37.43	190	166	Peak
ANTENNA POLARITY & TEST DISTANCE: VERTICAL AT 3 M										
FREQ. (MHz)	EMISSION LEVEL (dBuV/m)	READ LEVEL (dBuV)	LIMIT (dBuV/m)	MARGIN (dB)	ANTENNA FACTOR (dB/m)	CABLE LOSS (dB)	PREAMP FACTOR (dB)	ANTENNA HEIGHT (cm)	TABLE ANGLE (Degree)	REMARK
5418	39.21	38.54	54	-14.79	31.53	6.32	37.18	135	205	Average
5418	60.69	60.02	74	-13.31	31.53	6.32	37.18	135	205	Peak
5470	58.98	58.15	68.2	-9.22	31.57	6.34	37.08	135	205	Peak
5500	93.35	92.42			31.6	6.36	37.03	135	205	Average
5500	102.8	101.87			31.6	6.36	37.03	135	205	Peak
5725	60.13	58.85	68.2	-8.07	31.96	6.75	37.43	135	205	Peak

REMARKS:

- Emission Level = Read Level + Antenna Factor + Cable Loss - Preamp Factor
Margin value = Emission level – Limit value
- 5500 MHz: Fundamental frequency.
- 5470 MHz & 5725 MHz: Out of restricted band

EUT TEST CONDITION		MEASUREMENT DETAIL	
CHANNEL	Channel 116	FREQUENCY RANGE	1 GHz ~ 40 GHz
INPUT POWER	120 Vac, 60 Hz	DETECTOR FUNCTION	Peak (PK) Average (AV)
ENVIRONMENTAL CONDITIONS	25 deg. C, 65 % RH	TESTED BY	Gavin Wu

ANTENNA POLARITY & TEST DISTANCE: HORIZONTAL AT 3 M										
FREQ. (MHz)	EMISSION LEVEL (dBuV/m)	READ LEVEL (dBuV)	LIMIT (dBuV/m)	MARGIN (dB)	ANTENNA FACTOR (dB/m)	CABLE LOSS (dB)	PREAMP FACTOR (dB)	ANTENNA HEIGHT (cm)	TABLE ANGLE (Degree)	REMARK
5380	38.62	37.98	54	-15.38	31.51	6.31	37.18	189	177	Average
5380	60.25	59.61	74	-13.75	31.51	6.31	37.18	189	177	Peak
5470	60.14	59.31	68.2	-8.06	31.57	6.34	37.08	189	177	Peak
5580	93.77	92.73			31.71	6.49	37.16	189	177	Average
5580	103.45	102.41			31.71	6.49	37.16	189	177	Peak
5725	59.77	58.49	68.2	-8.43	31.96	6.75	37.43	189	177	Peak
ANTENNA POLARITY & TEST DISTANCE: VERTICAL AT 3 M										
FREQ. (MHz)	EMISSION LEVEL (dBuV/m)	READ LEVEL (dBuV)	LIMIT (dBuV/m)	MARGIN (dB)	ANTENNA FACTOR (dB/m)	CABLE LOSS (dB)	PREAMP FACTOR (dB)	ANTENNA HEIGHT (cm)	TABLE ANGLE (Degree)	REMARK
5378	38.81	38.17	54	-15.19	31.51	6.31	37.18	155	172	Average
5378	60.6	59.96	74	-13.4	31.51	6.31	37.18	155	172	Peak
5470	58.68	57.85	68.2	-9.52	31.57	6.34	37.08	155	172	Peak
5580	93.81	92.77			31.71	6.49	37.16	155	172	Average
5580	103.27	102.23			31.71	6.49	37.16	155	172	Peak
5725	59.62	58.34	68.2	-8.58	31.96	6.75	37.43	155	172	Peak

REMARKS:

- Emission Level = Read Level + Antenna Factor + Cable Loss - Preamp Factor
Margin value = Emission level – Limit value
- 5580 MHz: Fundamental frequency.
- 5470 MHz & 5725 MHz: Out of restricted band

EUT TEST CONDITION		MEASUREMENT DETAIL	
CHANNEL	Channel 140	FREQUENCY RANGE	1 GHz ~ 40 GHz
INPUT POWER	120 Vac, 60 Hz	DETECTOR FUNCTION	Peak (PK) Average (AV)
ENVIRONMENTAL CONDITIONS	25 deg. C, 65 % RH	TESTED BY	Gavin Wu

ANTENNA POLARITY & TEST DISTANCE: HORIZONTAL AT 3 M										
FREQ. (MHz)	EMISSION LEVEL (dBuV/m)	READ LEVEL (dBuV)	LIMIT (dBuV/m)	MARGIN (dB)	ANTENNA FACTOR (dB/m)	CABLE LOSS (dB)	PREAMP FACTOR (dB)	ANTENNA HEIGHT (cm)	TABLE ANGLE (Degree)	REMARK
5460	38.41	37.59	54	-15.59	31.56	6.34	37.08	201	158	Average
5460	59.95	59.13	74	-14.05	31.56	6.34	37.08	201	158	Peak
5470	58.6	57.77	68.2	-9.6	31.57	6.34	37.08	201	158	Peak
5700	94.95	93.76			31.9	6.69	37.4	201	158	Average
5700	103.51	102.32			31.9	6.69	37.4	201	158	Peak
5725	59.65	58.37	68.2	-8.55	31.96	6.75	37.43	201	158	Peak
ANTENNA POLARITY & TEST DISTANCE: VERTICAL AT 3 M										
FREQ. (MHz)	EMISSION LEVEL (dBuV/m)	READ LEVEL (dBuV)	LIMIT (dBuV/m)	MARGIN (dB)	ANTENNA FACTOR (dB/m)	CABLE LOSS (dB)	PREAMP FACTOR (dB)	ANTENNA HEIGHT (cm)	TABLE ANGLE (Degree)	REMARK
5446	38.71	37.94	54	-15.29	31.56	6.34	37.13	159	174	Average
5446	60.34	59.57	74	-13.66	31.56	6.34	37.13	159	174	Peak
5470	58.79	57.96	68.2	-9.41	31.57	6.34	37.08	159	174	Peak
5700	94.07	92.88			31.9	6.69	37.4	159	174	Average
5700	103.02	101.83			31.9	6.69	37.4	159	174	Peak
5725	62.73	61.45	68.2	-5.47	31.96	6.75	37.43	159	174	Peak

REMARKS:

- Emission Level = Read Level + Antenna Factor + Cable Loss - Preamp Factor
Margin value = Emission level – Limit value
- 5700 MHz: Fundamental frequency.
- 5470 MHz & 5725 MHz: Out of restricted band

EUT TEST CONDITION		MEASUREMENT DETAIL	
CHANNEL	Channel 149	FREQUENCY RANGE	1 GHz ~ 40 GHz
INPUT POWER	120 Vac, 60 Hz	DETECTOR FUNCTION	Peak (PK) Average (AV)
ENVIRONMENTAL CONDITIONS	25 deg. C, 65 % RH	TESTED BY	Gavin Wu

ANTENNA POLARITY & TEST DISTANCE: HORIZONTAL AT 3 M										
FREQ. (MHz)	EMISSION LEVEL (dBuV/m)	READ LEVEL (dBuV)	LIMIT (dBuV/m)	MARGIN (dB)	ANTENNA FACTOR (dB/m)	CABLE LOSS (dB)	PREAMP FACTOR (dB)	ANTENNA HEIGHT (cm)	TABLE ANGLE (Degree)	REMARK
5714	61.17	59.98	68.2	-7.03	31.93	6.69	37.43	185	175	Peak
5725	63.45	62.17	78.2	-14.75	31.96	6.75	37.43	185	175	Peak
5745	95.14	93.87			31.99	6.75	37.47	185	175	Average
5745	104.65	103.38			31.99	6.75	37.47	185	175	Peak
5850	60.38	58.86	78.2	-17.82	32.15	6.88	37.51	185	175	Peak
5861	60.51	58.88	68.2	-7.69	32.18	6.95	37.5	185	175	Peak
ANTENNA POLARITY & TEST DISTANCE: VERTICAL AT 3 M										
FREQ. (MHz)	EMISSION LEVEL (dBuV/m)	READ LEVEL (dBuV)	LIMIT (dBuV/m)	MARGIN (dB)	ANTENNA FACTOR (dB/m)	CABLE LOSS (dB)	PREAMP FACTOR (dB)	ANTENNA HEIGHT (cm)	TABLE ANGLE (Degree)	REMARK
5714	60.34	59.15	68.2	-7.86	31.93	6.69	37.43	100	204	Peak
5725	64.44	63.16	78.2	-13.76	31.96	6.75	37.43	100	204	Peak
5745	90.14	88.87			31.99	6.75	37.47	100	204	Average
5745	99.55	98.28			31.99	6.75	37.47	100	204	Peak
5850	59.79	58.27	78.2	-18.41	32.15	6.88	37.51	100	204	Peak
5861	59.89	58.26	68.2	-8.31	32.18	6.95	37.5	100	204	Peak

REMARKS:

- Emission Level = Read Level + Antenna Factor + Cable Loss - Preamp Factor
Margin value = Emission level – Limit value
- 5745 MHz: Fundamental frequency.
- 5714 MHz & 5725 MHz & 5850 MHz & 5861 MHz: Out of restricted band



A D T

EUT TEST CONDITION		MEASUREMENT DETAIL	
CHANNEL	Channel 157	FREQUENCY RANGE	1 GHz ~ 40 GHz
INPUT POWER	120 Vac, 60 Hz	DETECTOR FUNCTION	Peak (PK) Average (AV)
ENVIRONMENTAL CONDITIONS	25 deg. C, 65 % RH	TESTED BY	Gavin Wu

ANTENNA POLARITY & TEST DISTANCE: HORIZONTAL AT 3 M										
FREQ. (MHz)	EMISSION LEVEL (dBuV/m)	READ LEVEL (dBuV)	LIMIT (dBuV/m)	MARGIN (dB)	ANTENNA FACTOR (dB/m)	CABLE LOSS (dB)	PREAMP FACTOR (dB)	ANTENNA HEIGHT (cm)	TABLE ANGLE (Degree)	REMARK
5714	59.67	58.48	68.2	-8.53	31.93	6.69	37.43	195	169	Peak
5725	58.35	57.07	78.2	-19.85	31.96	6.75	37.43	195	169	Peak
5785	95.88	94.56			32.04	6.82	37.54	195	169	Average
5785	104.66	103.34			32.04	6.82	37.54	195	169	Peak
5850	59.3	57.78	78.2	-18.9	32.15	6.88	37.51	195	169	Peak
5861	59.77	58.14	68.2	-8.43	32.18	6.95	37.5	195	169	Peak
ANTENNA POLARITY & TEST DISTANCE: VERTICAL AT 3 M										
FREQ. (MHz)	EMISSION LEVEL (dBuV/m)	READ LEVEL (dBuV)	LIMIT (dBuV/m)	MARGIN (dB)	ANTENNA FACTOR (dB/m)	CABLE LOSS (dB)	PREAMP FACTOR (dB)	ANTENNA HEIGHT (cm)	TABLE ANGLE (Degree)	REMARK
5714	59.85	58.66	68.2	-8.35	31.93	6.69	37.43	105	206	Peak
5725	59.87	58.59	78.2	-18.33	31.96	6.75	37.43	105	206	Peak
5785	91.19	89.87			32.04	6.82	37.54	105	206	Average
5785	99.95	98.63			32.04	6.82	37.54	105	206	Peak
5850	61.58	60.06	78.2	-16.62	32.15	6.88	37.51	105	206	Peak
5861	59.93	58.3	68.2	-8.27	32.18	6.95	37.5	105	206	Peak

REMARKS:

- Emission Level = Read Level + Antenna Factor + Cable Loss - Preamp Factor
Margin value = Emission level – Limit value
- 5785 MHz: Fundamental frequency.
- 5714 MHz & 5725 MHz & 5850 MHz & 5861 MHz: Out of restricted band

EUT TEST CONDITION		MEASUREMENT DETAIL	
CHANNEL	Channel 165	FREQUENCY RANGE	1 GHz ~ 40 GHz
INPUT POWER	120 Vac, 60 Hz	DETECTOR FUNCTION	Peak (PK) Average (AV)
ENVIRONMENTAL CONDITIONS	25 deg. C, 65 % RH	TESTED BY	Gavin Wu

ANTENNA POLARITY & TEST DISTANCE: HORIZONTAL AT 3 M										
FREQ. (MHz)	EMISSION LEVEL (dBuV/m)	READ LEVEL (dBuV)	LIMIT (dBuV/m)	MARGIN (dB)	ANTENNA FACTOR (dB/m)	CABLE LOSS (dB)	PREAMP FACTOR (dB)	ANTENNA HEIGHT (cm)	TABLE ANGLE (Degree)	REMARK
5714	59.9	58.71	68.2	-8.3	31.93	6.69	37.43	199	169	Peak
5725	59.79	58.51	78.2	-18.41	31.96	6.75	37.43	199	169	Peak
5825	95.87	94.4			32.12	6.88	37.53	199	169	Average
5825	104.68	103.21			32.12	6.88	37.53	199	169	Peak
5850	63.17	61.65	78.2	-15.03	32.15	6.88	37.51	199	169	Peak
5861	60.41	58.78	68.2	-7.79	32.18	6.95	37.5	199	169	Peak
ANTENNA POLARITY & TEST DISTANCE: VERTICAL AT 3 M										
FREQ. (MHz)	EMISSION LEVEL (dBuV/m)	READ LEVEL (dBuV)	LIMIT (dBuV/m)	MARGIN (dB)	ANTENNA FACTOR (dB/m)	CABLE LOSS (dB)	PREAMP FACTOR (dB)	ANTENNA HEIGHT (cm)	TABLE ANGLE (Degree)	REMARK
5714	58.21	57.02	68.2	-9.99	31.93	6.69	37.43	104	207	Peak
5725	59.06	57.78	78.2	-19.14	31.96	6.75	37.43	104	207	Peak
5825	89.63	88.16			32.12	6.88	37.53	104	207	Average
5825	99.42	97.95			32.12	6.88	37.53	104	207	Peak
5850	59.61	58.09	78.2	-18.59	32.15	6.88	37.51	104	207	Peak
5861	60.29	58.66	68.2	-7.91	32.18	6.95	37.5	104	207	Peak

REMARKS:

- Emission Level = Read Level + Antenna Factor + Cable Loss - Preamp Factor
Margin value = Emission level – Limit value
- 5825 MHz: Fundamental frequency.
- 5714 MHz & 5725 MHz & 5850 MHz & 5861 MHz: Out of restricted band

802.11n (HT40)

EUT TEST CONDITION		MEASUREMENT DETAIL	
CHANNEL	Channel 38	FREQUENCY RANGE	1 GHz ~ 40 GHz
INPUT POWER	120 Vac, 60 Hz	DETECTOR FUNCTION	Peak (PK) Average (AV)
ENVIRONMENTAL CONDITIONS	25 deg. C, 65 % RH	TESTED BY	Gavin Wu

ANTENNA POLARITY & TEST DISTANCE: HORIZONTAL AT 3 M

FREQ. (MHz)	EMISSION LEVEL (dBuV/m)	READ LEVEL (dBuV)	LIMIT (dBuV/m)	MARGIN (dB)	ANTENNA FACTOR (dB/m)	CABLE LOSS (dB)	PREAMP FACTOR (dB)	ANTENNA HEIGHT (cm)	TABLE ANGLE (Degree)	REMARK
5148	44.18	43.98	54	-9.82	31.32	6.2	37.32	191	184	Average
5148	61.12	60.92	74	-12.88	31.32	6.2	37.32	191	184	Peak
5190	89.58	89.35			31.35	6.22	37.34	191	184	Average
5190	98.51	98.28			31.35	6.22	37.34	191	184	Peak
5370	38.57	37.95	54	-15.43	31.49	6.31	37.18	191	184	Average
5370	60.8	60.18	74	-13.2	31.49	6.31	37.18	191	184	Peak

ANTENNA POLARITY & TEST DISTANCE: VERTICAL AT 3 M

FREQ. (MHz)	EMISSION LEVEL (dBuV/m)	READ LEVEL (dBuV)	LIMIT (dBuV/m)	MARGIN (dB)	ANTENNA FACTOR (dB/m)	CABLE LOSS (dB)	PREAMP FACTOR (dB)	ANTENNA HEIGHT (cm)	TABLE ANGLE (Degree)	REMARK
5148	47.48	47.28	54	-6.52	31.32	6.2	37.32	195	134	Average
5148	62.71	62.51	74	-11.29	31.32	6.2	37.32	195	134	Peak
5190	91.56	91.33			31.35	6.22	37.34	195	134	Average
5190	100.51	100.28			31.35	6.22	37.34	195	134	Peak
5440	38.78	38.02	54	-15.22	31.55	6.34	37.13	195	134	Average
5440	60.66	59.9	74	-13.34	31.55	6.34	37.13	195	134	Peak

REMARKS:

- Emission Level = Read Level + Antenna Factor + Cable Loss - Preamp Factor
Margin value = Emission level – Limit value
- 5190 MHz: Fundamental frequency.



EUT TEST CONDITION		MEASUREMENT DETAIL	
CHANNEL	Channel 46	FREQUENCY RANGE	1 GHz ~ 40 GHz
INPUT POWER	120 Vac, 60 Hz	DETECTOR FUNCTION	Peak (PK) Average (AV)
ENVIRONMENTAL CONDITIONS	25 deg. C, 65 % RH	TESTED BY	Gavin Wu

ANTENNA POLARITY & TEST DISTANCE: HORIZONTAL AT 3 M										
FREQ. (MHz)	EMISSION LEVEL (dBuV/m)	READ LEVEL (dBuV)	LIMIT (dBuV/m)	MARGIN (dB)	ANTENNA FACTOR (dB/m)	CABLE LOSS (dB)	PREAMP FACTOR (dB)	ANTENNA HEIGHT (cm)	TABLE ANGLE (Degree)	REMARK
5002	39.03	38.93	54	-14.97	31.2	6.13	37.23	190	175	Average
5002	59.82	59.72	74	-14.18	31.2	6.13	37.23	190	175	Peak
5230	92.41	92.1			31.39	6.24	37.32	190	175	Average
5230	101.41	101.1			31.39	6.24	37.32	190	175	Peak
5388	38.82	38.18	54	-15.18	31.51	6.31	37.18	190	175	Average
5388	60.03	59.39	74	-13.97	31.51	6.31	37.18	190	175	Peak
ANTENNA POLARITY & TEST DISTANCE: VERTICAL AT 3 M										
FREQ. (MHz)	EMISSION LEVEL (dBuV/m)	READ LEVEL (dBuV)	LIMIT (dBuV/m)	MARGIN (dB)	ANTENNA FACTOR (dB/m)	CABLE LOSS (dB)	PREAMP FACTOR (dB)	ANTENNA HEIGHT (cm)	TABLE ANGLE (Degree)	REMARK
5116	39.76	39.56	54	-14.24	31.29	6.19	37.28	194	150	Average
5116	60.14	59.94	74	-13.86	31.29	6.19	37.28	194	150	Peak
5230	94.45	94.14			31.39	6.24	37.32	194	150	Average
5230	103.42	103.11			31.39	6.24	37.32	194	150	Peak
5364	39.61	38.99	54	-14.39	31.49	6.31	37.18	194	150	Average
5364	59.93	59.31	74	-14.07	31.49	6.31	37.18	194	150	Peak

REMARKS:

- Emission Level = Read Level + Antenna Factor + Cable Loss - Preamp Factor
Margin value = Emission level – Limit value
- 5230 MHz: Fundamental frequency.

EUT TEST CONDITION		MEASUREMENT DETAIL	
CHANNEL	Channel 54	FREQUENCY RANGE	1 GHz ~ 40 GHz
INPUT POWER	120 Vac, 60 Hz	DETECTOR FUNCTION	Peak (PK) Average (AV)
ENVIRONMENTAL CONDITIONS	25 deg. C, 65 % RH	TESTED BY	Gavin Wu

ANTENNA POLARITY & TEST DISTANCE: HORIZONTAL AT 3 M										
FREQ. (MHz)	EMISSION LEVEL (dBuV/m)	READ LEVEL (dBuV)	LIMIT (dBuV/m)	MARGIN (dB)	ANTENNA FACTOR (dB/m)	CABLE LOSS (dB)	PREAMP FACTOR (dB)	ANTENNA HEIGHT (cm)	TABLE ANGLE (Degree)	REMARK
5082	39.5	39.33	54	-14.5	31.27	6.17	37.27	200	159	Average
5082	59.93	59.76	74	-14.07	31.27	6.17	37.27	200	159	Peak
5270	92.95	92.56			31.41	6.25	37.27	200	159	Average
5270	101.76	101.37			31.41	6.25	37.27	200	159	Peak
5420	38.88	38.21	54	-15.12	31.53	6.32	37.18	200	159	Average
5420	60.45	59.78	74	-13.55	31.53	6.32	37.18	200	159	Peak
ANTENNA POLARITY & TEST DISTANCE: VERTICAL AT 3 M										
FREQ. (MHz)	EMISSION LEVEL (dBuV/m)	READ LEVEL (dBuV)	LIMIT (dBuV/m)	MARGIN (dB)	ANTENNA FACTOR (dB/m)	CABLE LOSS (dB)	PREAMP FACTOR (dB)	ANTENNA HEIGHT (cm)	TABLE ANGLE (Degree)	REMARK
5034	39.53	39.39	54	-14.47	31.23	6.15	37.24	201	143	Average
5034	60.15	60.01	74	-13.85	31.23	6.15	37.24	201	143	Peak
5270	93.57	93.18			31.41	6.25	37.27	201	143	Average
5270	102.98	102.59			31.41	6.25	37.27	201	143	Peak
5378	39.19	38.55	54	-14.81	31.51	6.31	37.18	201	143	Average
5378	59.76	59.12	74	-14.24	31.51	6.31	37.18	201	143	Peak

REMARKS:

- Emission Level = Read Level + Antenna Factor + Cable Loss - Preamp Factor
Margin value = Emission level – Limit value
- 5270 MHz: Fundamental frequency.

EUT TEST CONDITION		MEASUREMENT DETAIL	
CHANNEL	Channel 62	FREQUENCY RANGE	1 GHz ~ 40 GHz
INPUT POWER	120 Vac, 60 Hz	DETECTOR FUNCTION	Peak (PK) Average (AV)
ENVIRONMENTAL CONDITIONS	25 deg. C, 65 % RH	TESTED BY	Gavin Wu

ANTENNA POLARITY & TEST DISTANCE: HORIZONTAL AT 3 M										
FREQ. (MHz)	EMISSION LEVEL (dBuV/m)	READ LEVEL (dBuV)	LIMIT (dBuV/m)	MARGIN (dB)	ANTENNA FACTOR (dB/m)	CABLE LOSS (dB)	PREAMP FACTOR (dB)	ANTENNA HEIGHT (cm)	TABLE ANGLE (Degree)	REMARK
5086	38.43	38.26	54	-15.57	31.27	6.17	37.27	181	179	Average
5086	60.09	59.92	74	-13.91	31.27	6.17	37.27	181	179	Peak
5310	90.79	90.26			31.45	6.27	37.19	181	179	Average
5310	100	99.47			31.45	6.27	37.19	181	179	Peak
5350	45.32	44.73	54	-8.68	31.48	6.29	37.18	181	179	Average
5350	61.34	60.75	74	-12.66	31.48	6.29	37.18	181	179	Peak
ANTENNA POLARITY & TEST DISTANCE: VERTICAL AT 3 M										
FREQ. (MHz)	EMISSION LEVEL (dBuV/m)	READ LEVEL (dBuV)	LIMIT (dBuV/m)	MARGIN (dB)	ANTENNA FACTOR (dB/m)	CABLE LOSS (dB)	PREAMP FACTOR (dB)	ANTENNA HEIGHT (cm)	TABLE ANGLE (Degree)	REMARK
5138	38.84	38.63	54	-15.16	31.31	6.2	37.3	182	150	Average
5138	61.07	60.86	74	-12.93	31.31	6.2	37.3	182	150	Peak
5310	92.17	91.64			31.45	6.27	37.19	182	150	Average
5310	101.35	100.82			31.45	6.27	37.19	182	150	Peak
5350	47.67	47.08	54	-6.33	31.48	6.29	37.18	182	150	Average
5350	65.33	64.74	74	-8.67	31.48	6.29	37.18	182	150	Peak

REMARKS:

- Emission Level = Read Level + Antenna Factor + Cable Loss - Preamp Factor
Margin value = Emission level – Limit value
- 5310 MHz: Fundamental frequency.



EUT TEST CONDITION		MEASUREMENT DETAIL	
CHANNEL	Channel 102	FREQUENCY RANGE	1 GHz ~ 40 GHz
INPUT POWER	120 Vac, 60 Hz	DETECTOR FUNCTION	Peak (PK) Average (AV)
ENVIRONMENTAL CONDITIONS	25 deg. C, 65 % RH	TESTED BY	Gavin Wu

ANTENNA POLARITY & TEST DISTANCE: HORIZONTAL AT 3 M										
FREQ. (MHz)	EMISSION LEVEL (dBuV/m)	READ LEVEL (dBuV)	LIMIT (dBuV/m)	MARGIN (dB)	ANTENNA FACTOR (dB/m)	CABLE LOSS (dB)	PREAMP FACTOR (dB)	ANTENNA HEIGHT (cm)	TABLE ANGLE (Degree)	REMARK
5452	42.59	41.77	54	-11.41	31.56	6.34	37.08	180	212	Average
5452	61.27	60.45	74	-12.73	31.56	6.34	37.08	180	212	Peak
5470	63.44	62.61	68.2	-4.76	31.57	6.34	37.08	180	212	Peak
5510	91.28	90.38			31.6	6.36	37.06	180	212	Average
5510	101.79	100.89			31.6	6.36	37.06	180	212	Peak
5725	61.33	60.05	68.2	-6.87	31.96	6.75	37.43	180	212	Peak
ANTENNA POLARITY & TEST DISTANCE: VERTICAL AT 3 M										
FREQ. (MHz)	EMISSION LEVEL (dBuV/m)	READ LEVEL (dBuV)	LIMIT (dBuV/m)	MARGIN (dB)	ANTENNA FACTOR (dB/m)	CABLE LOSS (dB)	PREAMP FACTOR (dB)	ANTENNA HEIGHT (cm)	TABLE ANGLE (Degree)	REMARK
5456	43.24	42.42	54	-10.76	31.56	6.34	37.08	100	208	Average
5456	61.54	60.72	74	-12.46	31.56	6.34	37.08	100	208	Peak
5470	64.45	63.62	68.2	-3.75	31.57	6.34	37.08	100	208	Peak
5510	89.41	88.51			31.6	6.36	37.06	100	208	Average
5510	100.66	99.76			31.6	6.36	37.06	100	208	Peak
5725	61.02	59.74	68.2	-7.18	31.96	6.75	37.43	100	208	Peak

REMARKS:

- Emission Level = Read Level + Antenna Factor + Cable Loss - Preamp Factor
Margin value = Emission level – Limit value
- 5510 MHz: Fundamental frequency.
- 5470 MHz & 5725 MHz: Out of restricted band

EUT TEST CONDITION		MEASUREMENT DETAIL	
CHANNEL	Channel 110	FREQUENCY RANGE	1 GHz ~ 40 GHz
INPUT POWER	120 Vac, 60 Hz	DETECTOR FUNCTION	Peak (PK) Average (AV)
ENVIRONMENTAL CONDITIONS	25 deg. C, 65 % RH	TESTED BY	Gavin Wu

ANTENNA POLARITY & TEST DISTANCE: HORIZONTAL AT 3 M										
FREQ. (MHz)	EMISSION LEVEL (dBuV/m)	READ LEVEL (dBuV)	LIMIT (dBuV/m)	MARGIN (dB)	ANTENNA FACTOR (dB/m)	CABLE LOSS (dB)	PREAMP FACTOR (dB)	ANTENNA HEIGHT (cm)	TABLE ANGLE (Degree)	REMARK
5398	39.41	38.75	54	-14.59	31.52	6.32	37.18	168	213	Average
5398	60.84	60.18	74	-13.16	31.52	6.32	37.18	168	213	Peak
5470	60.06	59.23	68.2	-8.14	31.57	6.34	37.08	168	213	Peak
5550	91.18	90.17			31.68	6.42	37.09	168	213	Average
5550	100.99	99.98			31.68	6.42	37.09	168	213	Peak
5725	60.71	59.43	68.2	-7.49	31.96	6.75	37.43	168	213	Peak
ANTENNA POLARITY & TEST DISTANCE: VERTICAL AT 3 M										
FREQ. (MHz)	EMISSION LEVEL (dBuV/m)	READ LEVEL (dBuV)	LIMIT (dBuV/m)	MARGIN (dB)	ANTENNA FACTOR (dB/m)	CABLE LOSS (dB)	PREAMP FACTOR (dB)	ANTENNA HEIGHT (cm)	TABLE ANGLE (Degree)	REMARK
5396	39.52	38.87	54	-14.48	31.52	6.31	37.18	105	204	Average
5396	60.51	59.86	74	-13.49	31.52	6.31	37.18	105	204	Peak
5470	59.41	58.58	68.2	-8.79	31.57	6.34	37.08	105	204	Peak
5550	90.77	89.76			31.68	6.42	37.09	105	204	Average
5550	100.18	99.17			31.68	6.42	37.09	105	204	Peak
5725	60.97	59.69	68.2	-7.23	31.96	6.75	37.43	105	204	Peak

REMARKS:

- Emission Level = Read Level + Antenna Factor + Cable Loss - Preamp Factor
Margin value = Emission level – Limit value
- 5550 MHz: Fundamental frequency.
- 5470 MHz & 5725 MHz: Out of restricted band

EUT TEST CONDITION		MEASUREMENT DETAIL	
CHANNEL	Channel 134	FREQUENCY RANGE	1 GHz ~ 40 GHz
INPUT POWER	120 Vac, 60 Hz	DETECTOR FUNCTION	Peak (PK) Average (AV)
ENVIRONMENTAL CONDITIONS	25 deg. C, 65 % RH	TESTED BY	Gavin Wu

ANTENNA POLARITY & TEST DISTANCE: HORIZONTAL AT 3 M										
FREQ. (MHz)	EMISSION LEVEL (dBuV/m)	READ LEVEL (dBuV)	LIMIT (dBuV/m)	MARGIN (dB)	ANTENNA FACTOR (dB/m)	CABLE LOSS (dB)	PREAMP FACTOR (dB)	ANTENNA HEIGHT (cm)	TABLE ANGLE (Degree)	REMARK
5454	38.96	38.14	54	-15.04	31.56	6.34	37.08	186	213	Average
5454	61.21	60.39	74	-12.79	31.56	6.34	37.08	186	213	Peak
5470	60.52	59.69	68.2	-7.68	31.57	6.34	37.08	186	213	Peak
5670	89.67	88.51			31.88	6.62	37.34	186	213	Average
5670	100.38	99.22			31.88	6.62	37.34	186	213	Peak
5725	60.18	58.9	68.2	-8.02	31.96	6.75	37.43	186	213	Peak
ANTENNA POLARITY & TEST DISTANCE: VERTICAL AT 3 M										
FREQ. (MHz)	EMISSION LEVEL (dBuV/m)	READ LEVEL (dBuV)	LIMIT (dBuV/m)	MARGIN (dB)	ANTENNA FACTOR (dB/m)	CABLE LOSS (dB)	PREAMP FACTOR (dB)	ANTENNA HEIGHT (cm)	TABLE ANGLE (Degree)	REMARK
5360	39.12	38.51	54	-14.88	31.48	6.31	37.18	146	170	Average
5360	61.39	60.78	74	-12.61	31.48	6.31	37.18	146	170	Peak
5470	60	59.17	68.2	-8.2	31.57	6.34	37.08	146	170	Peak
5670	88.96	87.8			31.88	6.62	37.34	146	170	Average
5670	99.39	98.23			31.88	6.62	37.34	146	170	Peak
5725	61.08	59.8	68.2	-7.12	31.96	6.75	37.43	146	170	Peak

REMARKS:

- Emission Level = Read Level + Antenna Factor + Cable Loss - Preamp Factor
Margin value = Emission level – Limit value
- 5670 MHz: Fundamental frequency.
- 5470 MHz & 5725 MHz: Out of restricted band

EUT TEST CONDITION		MEASUREMENT DETAIL	
CHANNEL	Channel 151	FREQUENCY RANGE	1 GHz ~ 40 GHz
INPUT POWER	120 Vac, 60 Hz	DETECTOR FUNCTION	Peak (PK) Average (AV)
ENVIRONMENTAL CONDITIONS	25 deg. C, 65 % RH	TESTED BY	Gavin Wu

ANTENNA POLARITY & TEST DISTANCE: HORIZONTAL AT 3 M										
FREQ. (MHz)	EMISSION LEVEL (dBuV/m)	READ LEVEL (dBuV)	LIMIT (dBuV/m)	MARGIN (dB)	ANTENNA FACTOR (dB/m)	CABLE LOSS (dB)	PREAMP FACTOR (dB)	ANTENNA HEIGHT (cm)	TABLE ANGLE (Degree)	REMARK
5714	65.43	64.24	68.2	-2.77	31.93	6.69	37.43	182	167	Peak
5725	66.05	64.77	78.2	-12.15	31.96	6.75	37.43	182	167	Peak
5755	91.91	90.62			32.01	6.75	37.47	182	167	Average
5755	100.56	99.27			32.01	6.75	37.47	182	167	Peak
5850	60.41	58.89	78.2	-17.79	32.15	6.88	37.51	182	167	Peak
5861	59.38	57.75	68.2	-8.82	32.18	6.95	37.5	182	167	Peak
ANTENNA POLARITY & TEST DISTANCE: VERTICAL AT 3 M										
FREQ. (MHz)	EMISSION LEVEL (dBuV/m)	READ LEVEL (dBuV)	LIMIT (dBuV/m)	MARGIN (dB)	ANTENNA FACTOR (dB/m)	CABLE LOSS (dB)	PREAMP FACTOR (dB)	ANTENNA HEIGHT (cm)	TABLE ANGLE (Degree)	REMARK
5714	60.38	59.19	68.2	-7.82	31.93	6.69	37.43	100	204	Peak
5725	61.92	60.64	78.2	-16.28	31.96	6.75	37.43	100	204	Peak
5755	85.67	84.38			32.01	6.75	37.47	100	204	Average
5755	95.39	94.1			32.01	6.75	37.47	100	204	Peak
5850	59.48	57.96	78.2	-18.72	32.15	6.88	37.51	100	204	Peak
5861	60.27	58.64	68.2	-7.93	32.18	6.95	37.5	100	204	Peak

REMARKS:

- Emission Level = Read Level + Antenna Factor + Cable Loss - Preamp Factor
Margin value = Emission level – Limit value
- 5755 MHz: Fundamental frequency.
- 5714 MHz & 5725 MHz & 5850 MHz & 5861 MHz: Out of restricted band

EUT TEST CONDITION		MEASUREMENT DETAIL	
CHANNEL	Channel 159	FREQUENCY RANGE	1 GHz ~ 40 GHz
INPUT POWER	120 Vac, 60 Hz	DETECTOR FUNCTION	Peak (PK) Average (AV)
ENVIRONMENTAL CONDITIONS	25 deg. C, 65 % RH	TESTED BY	Gavin Wu

ANTENNA POLARITY & TEST DISTANCE: HORIZONTAL AT 3 M										
FREQ. (MHz)	EMISSION LEVEL (dBuV/m)	READ LEVEL (dBuV)	LIMIT (dBuV/m)	MARGIN (dB)	ANTENNA FACTOR (dB/m)	CABLE LOSS (dB)	PREAMP FACTOR (dB)	ANTENNA HEIGHT (cm)	TABLE ANGLE (Degree)	REMARK
5714	58.2	57.01	68.2	-10	31.93	6.69	37.43	180	159	Peak
5725	60.83	59.55	78.2	-17.37	31.96	6.75	37.43	180	159	Peak
5795	92.67	91.32			32.07	6.82	37.54	180	159	Average
5795	101.09	99.74			32.07	6.82	37.54	180	159	Peak
5850	59.74	58.22	78.2	-18.46	32.15	6.88	37.51	180	159	Peak
5861	60.97	59.34	68.2	-7.23	32.18	6.95	37.5	180	159	Peak
ANTENNA POLARITY & TEST DISTANCE: VERTICAL AT 3 M										
FREQ. (MHz)	EMISSION LEVEL (dBuV/m)	READ LEVEL (dBuV)	LIMIT (dBuV/m)	MARGIN (dB)	ANTENNA FACTOR (dB/m)	CABLE LOSS (dB)	PREAMP FACTOR (dB)	ANTENNA HEIGHT (cm)	TABLE ANGLE (Degree)	REMARK
5714	61.08	59.89	68.2	-7.12	31.93	6.69	37.43	129	206	Peak
5725	59.58	58.3	78.2	-18.62	31.96	6.75	37.43	129	206	Peak
5795	86.52	85.17			32.07	6.82	37.54	129	206	Average
5795	96.11	94.76			32.07	6.82	37.54	129	206	Peak
5850	60.01	58.49	78.2	-18.19	32.15	6.88	37.51	129	206	Peak
5861	59.95	58.32	68.2	-8.25	32.18	6.95	37.5	129	206	Peak

REMARKS:

- Emission Level = Read Level + Antenna Factor + Cable Loss - Preamp Factor
Margin value = Emission level – Limit value
- 5795 MHz: Fundamental frequency.
- 5714 MHz & 5725 MHz & 5850 MHz & 5861 MHz: Out of restricted band

802.11ac (VHT80)

EUT TEST CONDITION		MEASUREMENT DETAIL	
CHANNEL	Channel 42	FREQUENCY RANGE	1 GHz ~ 40 GHz
INPUT POWER	120 Vac, 60 Hz	DETECTOR FUNCTION	Peak (PK) Average (AV)
ENVIRONMENTAL CONDITIONS	25 deg. C, 65 % RH	TESTED BY	Gavin Wu

ANTENNA POLARITY & TEST DISTANCE: HORIZONTAL AT 3 M

FREQ. (MHz)	EMISSION LEVEL (dBuV/m)	READ LEVEL (dBuV)	LIMIT (dBuV/m)	MARGIN (dB)	ANTENNA FACTOR (dB/m)	CABLE LOSS (dB)	PREAMP FACTOR (dB)	ANTENNA HEIGHT (cm)	TABLE ANGLE (Degree)	REMARK
5100	41.31	41.12	54	-12.69	31.28	6.19	37.28	179	153	Average
5100	60.79	60.6	74	-13.21	31.28	6.19	37.28	179	153	Peak
5210	82.76	82.51			31.37	6.24	37.36	179	153	Average
5210	92.98	92.73			31.37	6.24	37.36	179	153	Peak
5398	38.8	38.14	54	-15.2	31.52	6.32	37.18	179	153	Average
5398	60.68	60.02	74	-13.32	31.52	6.32	37.18	179	153	Peak

ANTENNA POLARITY & TEST DISTANCE: VERTICAL AT 3 M

FREQ. (MHz)	EMISSION LEVEL (dBuV/m)	READ LEVEL (dBuV)	LIMIT (dBuV/m)	MARGIN (dB)	ANTENNA FACTOR (dB/m)	CABLE LOSS (dB)	PREAMP FACTOR (dB)	ANTENNA HEIGHT (cm)	TABLE ANGLE (Degree)	REMARK
5122	39.11	38.93	54	-14.89	31.29	6.19	37.3	106	213	Average
5122	60.02	59.84	74	-13.98	31.29	6.19	37.3	106	213	Peak
5210	76.4	76.15			31.37	6.24	37.36	106	213	Average
5210	87.24	86.99			31.37	6.24	37.36	106	213	Peak
5452	38.72	37.9	54	-15.28	31.56	6.34	37.08	106	213	Average
5452	59.61	58.79	74	-14.39	31.56	6.34	37.08	106	213	Peak

REMARKS:

- Emission Level = Read Level + Antenna Factor + Cable Loss - Preamp Factor
Margin value = Emission level – Limit value
- 5210 MHz: Fundamental frequency.

EUT TEST CONDITION		MEASUREMENT DETAIL	
CHANNEL	Channel 58	FREQUENCY RANGE	1 GHz ~ 40 GHz
INPUT POWER	120 Vac, 60 Hz	DETECTOR FUNCTION	Peak (PK) Average (AV)
ENVIRONMENTAL CONDITIONS	25 deg. C, 65 % RH	TESTED BY	Gavin Wu

ANTENNA POLARITY & TEST DISTANCE: HORIZONTAL AT 3 M										
FREQ. (MHz)	EMISSION LEVEL (dBuV/m)	READ LEVEL (dBuV)	LIMIT (dBuV/m)	MARGIN (dB)	ANTENNA FACTOR (dB/m)	CABLE LOSS (dB)	PREAMP FACTOR (dB)	ANTENNA HEIGHT (cm)	TABLE ANGLE (Degree)	REMARK
5034	37.86	37.72	54	-16.14	31.23	6.15	37.24	185	175	Average
5034	59.56	59.42	74	-14.44	31.23	6.15	37.24	185	175	Peak
5290	81.62	81.15			31.43	6.27	37.23	185	175	Average
5290	93.4	92.93			31.43	6.27	37.23	185	175	Peak
5366	45.67	45.05	54	-8.33	31.49	6.31	37.18	185	175	Average
5366	63.89	63.27	74	-10.11	31.49	6.31	37.18	185	175	Peak

ANTENNA POLARITY & TEST DISTANCE: VERTICAL AT 3 M										
FREQ. (MHz)	EMISSION LEVEL (dBuV/m)	READ LEVEL (dBuV)	LIMIT (dBuV/m)	MARGIN (dB)	ANTENNA FACTOR (dB/m)	CABLE LOSS (dB)	PREAMP FACTOR (dB)	ANTENNA HEIGHT (cm)	TABLE ANGLE (Degree)	REMARK
5116	39.75	39.55	54	-14.25	31.29	6.19	37.28	105	213	Average
5116	59.54	59.34	74	-14.46	31.29	6.19	37.28	105	213	Peak
5290	76.43	75.96			31.43	6.27	37.23	105	213	Average
5290	87.43	86.96			31.43	6.27	37.23	105	213	Peak
5354	41.05	40.46	54	-12.95	31.48	6.29	37.18	105	213	Average
5354	60.11	59.52	74	-13.89	31.48	6.29	37.18	105	213	Peak

REMARKS:

- Emission Level = Read Level + Antenna Factor + Cable Loss - Preamp Factor
Margin value = Emission level – Limit value
- 5290 MHz: Fundamental frequency.



A D T

EUT TEST CONDITION		MEASUREMENT DETAIL	
CHANNEL	Channel 106	FREQUENCY RANGE	1 GHz ~ 40 GHz
INPUT POWER	120 Vac, 60 Hz	DETECTOR FUNCTION	Peak (PK) Average (AV)
ENVIRONMENTAL CONDITIONS	25 deg. C, 65 % RH	TESTED BY	Gavin Wu

ANTENNA POLARITY & TEST DISTANCE: HORIZONTAL AT 3 M										
FREQ. (MHz)	EMISSION LEVEL (dBuV/m)	READ LEVEL (dBuV)	LIMIT (dBuV/m)	MARGIN (dB)	ANTENNA FACTOR (dB/m)	CABLE LOSS (dB)	PREAMP FACTOR (dB)	ANTENNA HEIGHT (cm)	TABLE ANGLE (Degree)	REMARK
5422	41.96	41.29	54	-12.04	31.53	6.32	37.18	166	210	Average
5422	61.06	60.39	74	-12.94	31.53	6.32	37.18	166	210	Peak
5470	60.71	59.88	68.2	-7.49	31.57	6.34	37.08	166	210	Peak
5530	83.3	82.34			31.63	6.42	37.09	166	210	Average
5530	94.4	93.44			31.63	6.42	37.09	166	210	Peak
5725	61.55	60.27	68.2	-6.65	31.96	6.75	37.43	166	210	Peak

ANTENNA POLARITY & TEST DISTANCE: VERTICAL AT 3 M										
FREQ. (MHz)	EMISSION LEVEL (dBuV/m)	READ LEVEL (dBuV)	LIMIT (dBuV/m)	MARGIN (dB)	ANTENNA FACTOR (dB/m)	CABLE LOSS (dB)	PREAMP FACTOR (dB)	ANTENNA HEIGHT (cm)	TABLE ANGLE (Degree)	REMARK
5458	42.2	41.38	54	-11.8	31.56	6.34	37.08	120	209	Average
5458	61.26	60.44	74	-12.74	31.56	6.34	37.08	120	209	Peak
5470	59.56	58.73	68.2	-8.64	31.57	6.34	37.08	120	209	Peak
5530	82.43	81.47			31.63	6.42	37.09	120	209	Average
5530	93.32	92.36			31.63	6.42	37.09	120	209	Peak
5725	62.68	61.4	68.2	-5.52	31.96	6.75	37.43	120	209	Peak

REMARKS:

- Emission Level = Read Level + Antenna Factor + Cable Loss - Preamp Factor
Margin value = Emission level – Limit value
- 5530 MHz: Fundamental frequency.
- 5470 MHz & 5725 MHz: Out of restricted band

EUT TEST CONDITION		MEASUREMENT DETAIL	
CHANNEL	Channel 122	FREQUENCY RANGE	1 GHz ~ 40 GHz
INPUT POWER	120 Vac, 60 Hz	DETECTOR FUNCTION	Peak (PK) Average (AV)
ENVIRONMENTAL CONDITIONS	25 deg. C, 65 % RH	TESTED BY	Gavin Wu

ANTENNA POLARITY & TEST DISTANCE: HORIZONTAL AT 3 M										
FREQ. (MHz)	EMISSION LEVEL (dBuV/m)	READ LEVEL (dBuV)	LIMIT (dBuV/m)	MARGIN (dB)	ANTENNA FACTOR (dB/m)	CABLE LOSS (dB)	PREAMP FACTOR (dB)	ANTENNA HEIGHT (cm)	TABLE ANGLE (Degree)	REMARK
5356	39.26	38.67	54	-14.74	31.48	6.29	37.18	160	212	Average
5356	60.75	60.16	74	-13.25	31.48	6.29	37.18	160	212	Peak
5470	59.3	58.47	68.2	-8.9	31.57	6.34	37.08	160	212	Peak
5610	83.66	82.55			31.77	6.56	37.22	160	212	Average
5610	94.88	93.77			31.77	6.56	37.22	160	212	Peak
5725	59.7	58.42	68.2	-8.5	31.96	6.75	37.43	160	212	Peak
ANTENNA POLARITY & TEST DISTANCE: VERTICAL AT 3 M										
FREQ. (MHz)	EMISSION LEVEL (dBuV/m)	READ LEVEL (dBuV)	LIMIT (dBuV/m)	MARGIN (dB)	ANTENNA FACTOR (dB/m)	CABLE LOSS (dB)	PREAMP FACTOR (dB)	ANTENNA HEIGHT (cm)	TABLE ANGLE (Degree)	REMARK
5356	39.15	38.56	54	-14.85	31.48	6.29	37.18	111	208	Average
5356	60.67	60.08	74	-13.33	31.48	6.29	37.18	111	208	Peak
5470	59.05	58.22	68.2	-9.15	31.57	6.34	37.08	111	208	Peak
5610	83.12	82.01			31.77	6.56	37.22	111	208	Average
5610	93.88	92.77			31.77	6.56	37.22	111	208	Peak
5725	61.11	59.83	68.2	-7.09	31.96	6.75	37.43	111	208	Peak

REMARKS:

- Emission Level = Read Level + Antenna Factor + Cable Loss - Preamp Factor
Margin value = Emission level – Limit value
- 5610 MHz: Fundamental frequency.
- 5470 MHz & 5725 MHz: Out of restricted band

EUT TEST CONDITION		MEASUREMENT DETAIL	
CHANNEL	Channel 155	FREQUENCY RANGE	1 GHz ~ 40 GHz
INPUT POWER	120 Vac, 60 Hz	DETECTOR FUNCTION	Peak (PK) Average (AV)
ENVIRONMENTAL CONDITIONS	25 deg. C, 65 % RH	TESTED BY	Gavin Wu

ANTENNA POLARITY & TEST DISTANCE: HORIZONTAL AT 3 M										
FREQ. (MHz)	EMISSION LEVEL (dBuV/m)	READ LEVEL (dBuV)	LIMIT (dBuV/m)	MARGIN (dB)	ANTENNA FACTOR (dB/m)	CABLE LOSS (dB)	PREAMP FACTOR (dB)	ANTENNA HEIGHT (cm)	TABLE ANGLE (Degree)	REMARK
5714	59.76	58.57	68.2	-8.44	31.93	6.69	37.43	193	159	Peak
5725	60.34	59.06	78.2	-17.86	31.96	6.75	37.43	193	159	Peak
5775	81.71	80.35			32.04	6.82	37.5	193	159	Average
5775	92.66	91.3			32.04	6.82	37.5	193	159	Peak
5850	60.51	58.99	78.2	-17.69	32.15	6.88	37.51	193	159	Peak
5861	61.04	59.41	68.2	-7.16	32.18	6.95	37.5	193	159	Peak
ANTENNA POLARITY & TEST DISTANCE: VERTICAL AT 3 M										
FREQ. (MHz)	EMISSION LEVEL (dBuV/m)	READ LEVEL (dBuV)	LIMIT (dBuV/m)	MARGIN (dB)	ANTENNA FACTOR (dB/m)	CABLE LOSS (dB)	PREAMP FACTOR (dB)	ANTENNA HEIGHT (cm)	TABLE ANGLE (Degree)	REMARK
5714	59.36	58.17	68.2	-8.84	31.93	6.69	37.43	114	204	Peak
5725	58.75	57.47	78.2	-19.45	31.96	6.75	37.43	114	204	Peak
5775	75.95	74.59			32.04	6.82	37.5	114	204	Average
5775	87.02	85.66			32.04	6.82	37.5	114	204	Peak
5850	59.03	57.51	78.2	-19.17	32.15	6.88	37.51	114	204	Peak
5861	59.18	57.55	68.2	-9.02	32.18	6.95	37.5	114	204	Peak

REMARKS:

- Emission Level = Read Level + Antenna Factor + Cable Loss - Preamp Factor
Margin value = Emission level – Limit value
- 5775 MHz: Fundamental frequency.
- 5714 MHz & 5725 MHz & 5850 MHz & 5861 MHz: Out of restricted band

9 kHz ~ 30 MHz DATA:

The amplitude of spurious emissions attenuated more than 20 dB below the permissible value is not required to be report.

30 MHz ~ 1 GHz WORST-CASE DATA:
802.11n (HT40)

EUT TEST CONDITION		MEASUREMENT DETAIL	
CHANNEL	Channel 38	FREQUENCY RANGE	30 MHz ~ 1 GHz
INPUT POWER	120 Vac, 60 Hz	DETECTOR FUNCTION	Peak (PK) Quasi-peak (QP)
ENVIRONMENTAL CONDITIONS	25 deg. C, 65 % RH	TESTED BY	Gavin Wu

ANTENNA POLARITY & TEST DISTANCE: HORIZONTAL AT 3 M

FREQ. (MHz)	EMISSION LEVEL (dBuV/m)	READ LEVEL (dBuV)	LIMIT (dBuV/m)	MARGIN (dB)	ANTENNA FACTOR (dB/m)	CABLE LOSS (dB)	PREAMP FACTOR (dB)	ANTENNA HEIGHT (cm)	TABLE ANGLE (Degree)	REMARK
126.03	27.25	46.58	43.5	-16.25	11.42	1.14	31.89	121	268	Peak
177.44	27.26	46.87	43.5	-16.24	11.01	1.19	31.81	112	228	Peak
218.18	24.04	44.23	46	-21.96	10.13	1.37	31.69	114	227	Peak
663.41	22.88	32.03	46	-23.12	20.37	2.38	31.9	115	249	Peak
699.3	23.45	31.98	46	-22.55	20.81	2.45	31.79	104	258	Peak
743.92	23.75	31.19	46	-22.25	21.44	2.53	31.41	101	220	Peak

ANTENNA POLARITY & TEST DISTANCE: VERTICAL AT 3 M

FREQ. (MHz)	EMISSION LEVEL (dBuV/m)	READ LEVEL (dBuV)	LIMIT (dBuV/m)	MARGIN (dB)	ANTENNA FACTOR (dB/m)	CABLE LOSS (dB)	PREAMP FACTOR (dB)	ANTENNA HEIGHT (cm)	TABLE ANGLE (Degree)	REMARK
50.37	25.25	42.89	40	-14.75	12.97	0.7	31.31	100	15	Peak
195.87	25.85	46.66	43.5	-17.65	9.64	1.28	31.73	100	99	Peak
528.58	19.36	30.93	46	-26.64	17.97	2.14	31.68	118	46	Peak
663.41	22.49	31.64	46	-23.51	20.37	2.38	31.9	106	159	Peak
750.71	24.26	31.51	46	-21.74	21.53	2.53	31.31	101	193	Peak
764.29	24.37	31.48	46	-21.63	21.72	2.56	31.39	112	355	Peak

REMARKS: Emission Level = Read Level + Antenna Factor + Cable Loss - Preamp Factor

Margin value = Emission level – Limit value



A D T

802.11n (HT40)

EUT TEST CONDITION		MEASUREMENT DETAIL	
CHANNEL	Channel 62	FREQUENCY RANGE	30 MHz ~ 1 GHz
INPUT POWER	120 Vac, 60 Hz	DETECTOR FUNCTION	Peak (PK) Quasi-peak (QP)
ENVIRONMENTAL CONDITIONS	25 deg. C, 65 % RH	TESTED BY	Gavin Wu

ANTENNA POLARITY & TEST DISTANCE: HORIZONTAL AT 3 M

FREQ. (MHz)	EMISSION LEVEL (dBuV/m)	READ LEVEL (dBuV)	LIMIT (dBuV/m)	MARGIN (dB)	ANTENNA FACTOR (dB/m)	CABLE LOSS (dB)	PREAMP FACTOR (dB)	ANTENNA HEIGHT (cm)	TABLE ANGLE (Degree)	REMARK
127.97	28.66	47.85	43.5	-14.84	11.55	1.14	31.88	123	157	Peak
180.35	24.39	44.27	43.5	-19.11	10.74	1.22	31.84	126	157	Peak
224.97	20.25	40.21	46	-25.75	10.42	1.4	31.78	131	353	Peak
638.19	22.06	31.76	46	-23.94	20.07	2.33	32.1	104	351	Peak
696.39	23.53	32.12	46	-22.47	20.77	2.45	31.81	134	142	Peak
759.44	24.18	31.41	46	-21.82	21.66	2.55	31.44	108	120	Peak

ANTENNA POLARITY & TEST DISTANCE: VERTICAL AT 3 M

FREQ. (MHz)	EMISSION LEVEL (dBuV/m)	READ LEVEL (dBuV)	LIMIT (dBuV/m)	MARGIN (dB)	ANTENNA FACTOR (dB/m)	CABLE LOSS (dB)	PREAMP FACTOR (dB)	ANTENNA HEIGHT (cm)	TABLE ANGLE (Degree)	REMARK
45.52	26.18	43.16	40	-13.82	13.5	0.68	31.16	120	192	Peak
50.37	25.45	43.09	40	-14.55	12.97	0.7	31.31	101	104	Peak
194.9	25.34	46.09	43.5	-18.16	9.7	1.27	31.72	136	321	Peak
630.43	22.04	31.9	46	-23.96	19.97	2.31	32.14	120	350	Peak
679.9	23.07	31.92	46	-22.93	20.57	2.42	31.84	131	52	Peak
751.68	23.95	31.2	46	-22.05	21.55	2.53	31.33	122	355	Peak

REMARKS: Emission Level = Read Level + Antenna Factor + Cable Loss - Preamp Factor

Margin value = Emission level – Limit value



802.11n (HT40)

EUT TEST CONDITION		MEASUREMENT DETAIL	
CHANNEL	Channel 102	FREQUENCY RANGE	30 MHz ~ 1 GHz
INPUT POWER	120 Vac, 60 Hz	DETECTOR FUNCTION	Peak (PK) Quasi-peak (QP)
ENVIRONMENTAL CONDITIONS	25 deg. C, 65 % RH	TESTED BY	Gavin Wu

ANTENNA POLARITY & TEST DISTANCE: HORIZONTAL AT 3 M										
FREQ. (MHz)	EMISSION LEVEL (dBuV/m)	READ LEVEL (dBuV)	LIMIT (dBuV/m)	MARGIN (dB)	ANTENNA FACTOR (dB/m)	CABLE LOSS (dB)	PREAMP FACTOR (dB)	ANTENNA HEIGHT (cm)	TABLE ANGLE (Degree)	REMARK
127	28.6	47.87	43.5	-14.9	11.48	1.14	31.89	121	125	Peak
180.35	23.96	43.84	43.5	-19.54	10.74	1.22	31.84	140	6	Peak
220.12	22.76	42.87	46	-23.24	10.22	1.38	31.71	118	155	Peak
644.01	22.16	31.74	46	-23.84	20.14	2.34	32.06	133	109	Peak
689.6	23.17	31.88	46	-22.83	20.69	2.44	31.84	130	268	Peak
741.01	23.65	31.2	46	-22.35	21.39	2.52	31.46	136	136	Peak
ANTENNA POLARITY & TEST DISTANCE: VERTICAL AT 3 M										
FREQ. (MHz)	EMISSION LEVEL (dBuV/m)	READ LEVEL (dBuV)	LIMIT (dBuV/m)	MARGIN (dB)	ANTENNA FACTOR (dB/m)	CABLE LOSS (dB)	PREAMP FACTOR (dB)	ANTENNA HEIGHT (cm)	TABLE ANGLE (Degree)	REMARK
46.49	26.32	43.44	40	-13.68	13.39	0.68	31.19	140	92	Peak
196.84	23.63	44.52	43.5	-19.87	9.57	1.28	31.74	106	173	Peak
342.34	18.79	34.9	46	-27.21	13.96	1.75	31.82	134	285	Peak
645.95	22.11	31.65	46	-23.89	20.16	2.35	32.05	106	14	Peak
723.55	24.36	32.35	46	-21.64	21.15	2.49	31.63	120	202	Peak
763.32	25.83	32.98	46	-20.17	21.71	2.55	31.41	102	257	Peak

REMARKS: Emission Level = Read Level + Antenna Factor + Cable Loss - Preamp Factor

Margin value = Emission level – Limit value



802.11n (HT40)

EUT TEST CONDITION		MEASUREMENT DETAIL	
CHANNEL	Channel 151	FREQUENCY RANGE	30 MHz ~ 1 GHz
INPUT POWER	120 Vac, 60 Hz	DETECTOR FUNCTION	Peak (PK) Quasi-peak (QP)
ENVIRONMENTAL CONDITIONS	25 deg. C, 65 % RH	TESTED BY	Gavin Wu

ANTENNA POLARITY & TEST DISTANCE: HORIZONTAL AT 3 M										
FREQ. (MHz)	EMISSION LEVEL (dBuV/m)	READ LEVEL (dBuV)	LIMIT (dBuV/m)	MARGIN (dB)	ANTENNA FACTOR (dB/m)	CABLE LOSS (dB)	PREAMP FACTOR (dB)	ANTENNA HEIGHT (cm)	TABLE ANGLE (Degree)	REMARK
127.97	27.36	46.55	43.5	-16.14	11.55	1.14	31.88	134	76	Peak
180.35	24.44	44.32	43.5	-19.06	10.74	1.22	31.84	110	296	Peak
341.37	21.11	37.25	46	-24.89	13.94	1.74	31.82	139	307	Peak
649.83	22.95	32.4	46	-23.05	20.21	2.36	32.02	128	286	Peak
697.36	23.08	31.65	46	-22.92	20.78	2.45	31.8	138	291	Peak
767.2	24.87	31.89	46	-21.13	21.76	2.56	31.34	120	183	Peak
ANTENNA POLARITY & TEST DISTANCE: VERTICAL AT 3 M										
FREQ. (MHz)	EMISSION LEVEL (dBuV/m)	READ LEVEL (dBuV)	LIMIT (dBuV/m)	MARGIN (dB)	ANTENNA FACTOR (dB/m)	CABLE LOSS (dB)	PREAMP FACTOR (dB)	ANTENNA HEIGHT (cm)	TABLE ANGLE (Degree)	REMARK
191.99	25.17	45.68	43.5	-18.33	9.91	1.27	31.69	117	209	Peak
200.72	21.67	42.73	43.5	-21.83	9.4	1.29	31.75	104	273	Peak
346.22	18.76	34.79	46	-27.24	14.05	1.75	31.83	134	82	Peak
639.16	22.93	32.62	46	-23.07	20.08	2.33	32.1	131	22	Peak
701.24	23.29	31.79	46	-22.71	20.83	2.45	31.78	100	335	Peak
773.02	24.44	31.36	46	-21.56	21.85	2.57	31.34	102	282	Peak

REMARKS: Emission Level = Read Level + Antenna Factor + Cable Loss - Preamp Factor

Margin value = Emission level – Limit value

4.2 Conducted Emission Measurement

4.2.1 Limits of Conducted Emission Measurement

Frequency (MHz)	Conducted Limit (dBuV)	
	Quasi-peak	Average
0.15 - 0.5	66 - 56	56 - 46
0.50 - 5.0	56	46
5.0 - 30.0	60	50

Note: 1. The lower limit shall apply at the transition frequencies.

2. The limit decreases in line with the logarithm of the frequency in the range of 0.15 to 0.50 MHz.

4.2.2 Test Instruments

Description & Manufacturer	Model No.	Serial No.	Date Of Calibration	Due Date Of Calibration
Test Receiver ROHDE & SCHWARZ	ESCI	100613	Nov. 16, 2015	Nov. 15, 2016
RF signal cable (with 10dB PAD) Woken	5D-FB	Cable-cond1-01	Dec. 26, 2014	Dec. 25, 2015
LISN ROHDE & SCHWARZ (EUT)	ESH3-Z5	835239/001	Feb. 26, 2015	Feb. 25, 2016
LISN ROHDE & SCHWARZ (Peripheral)	ESH3-Z5	100311	Jul. 24, 2015	Jul. 23, 2016
Software ADT	BV ADT_Cond_ V7.3.7.3	NA	NA	NA

Note: 1. The calibration interval of the above test instruments is 12 months and the calibrations are traceable to NML/ROC and NIST/USA.

2. The test was performed in HwaYa Shielded Room 1.

3. The VCCI Site Registration No. is C-2040.

4.2.3 Test Procedures

- a. The EUT was placed 0.4 meters from the conducting wall of the shielded room with EUT being connected to the power mains through a line impedance stabilization network (LISN). Other support units were connected to the power mains through another LISN. The two LISNs provide 50 ohm/ 50uH of coupling impedance for the measuring instrument.
- b. Both lines of the power mains connected to the EUT were checked for maximum conducted interference.
- c. The frequency range from 150 kHz to 30 MHz was searched. Emission levels under (Limit -20 dB) was not recorded.

NOTE: All modes of operation were investigated and the worst-case emissions are reported.

4.2.4 Deviation from Test Standard

No deviation.

4.2.5 Test Setup

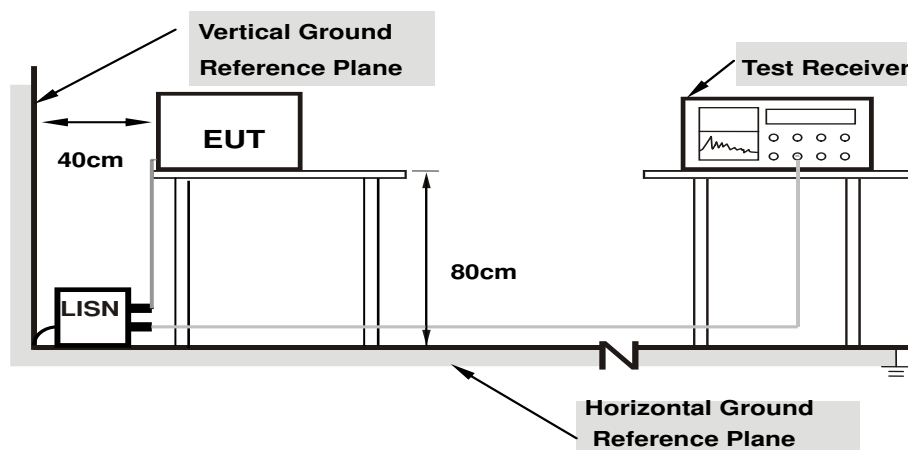

- Note:**
1. Support units were connected to second LISN.
 2. Both of LISNs (AMN) are 80 cm from EUT and at least 80 from other units and other metal planes

For the actual test configuration, please refer to the attached file (Test Setup Photo).

4.2.6 EUT Operating Conditions

- a. Placed the EUT on a testing table.
- b. Use the software to control the EUT under transmission condition continuously at specific channel frequency.

4.2.7 Test Results

Frequency Range	150kHz ~ 30MHz	Detector Function & Resolution Bandwidth	Quasi-Peak (QP) / Average (AV), 9kHz
Input Power	120Vac, 60Hz	Environmental Conditions	25°C, 65%RH
Tested by	Toby Tian	Test Date	2015/11/21

Phase Of Power : Line (L)										
No	Frequency (MHz)	Correction Factor (dB)	Reading Value (dBuV)		Emission Level (dBuV)		Limit (dBuV)		Margin (dB)	
			Q.P.	AV.	Q.P.	AV.	Q.P.	AV.	Q.P.	AV.
1	0.15000	9.82	35.91	22.73	45.73	32.55	66.00	56.00	-20.27	-23.45
2	0.16955	9.83	34.88	19.59	44.71	29.42	64.98	54.98	-20.27	-25.56
3	0.19717	9.84	30.55	15.47	40.39	25.31	63.73	53.73	-23.34	-28.42
4	0.31432	9.86	22.80	9.34	32.66	19.20	59.86	49.86	-27.19	-30.65
5	0.47844	9.89	17.25	7.09	27.14	16.98	56.37	46.37	-29.23	-29.39
6	3.77848	10.12	24.43	14.54	34.55	24.66	56.00	46.00	-21.45	-21.34

Remarks:

1. Q.P. and AV. are abbreviations of quasi-peak and average individually.
2. The emission levels of other frequencies were very low against the limit.
3. Margin value = Emission level – Limit value
4. Correction factor = Insertion loss + Cable loss
5. Emission Level = Correction Factor + Reading Value

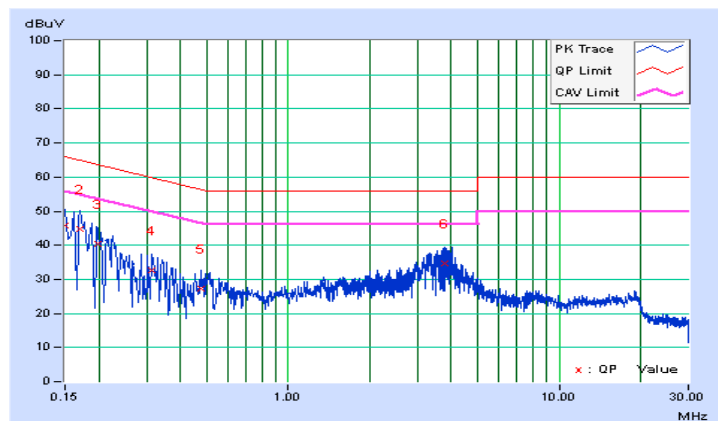

Frequency Range	150kHz ~ 30MHz	Detector Function & Resolution Bandwidth	Quasi-Peak (QP) / Average (AV), 9kHz
Input Power	120Vac, 60Hz	Environmental Conditions	25°C, 65%RH
Tested by	Toby Tian	Test Date	2015/11/21

Phase Of Power : Neutral (N)										
No	Frequency (MHz)	Correction Factor (dB)	Reading Value (dBuV)		Emission Level (dBuV)		Limit (dBuV)		Margin (dB)	
			Q.P.	AV.	Q.P.	AV.	Q.P.	AV.	Q.P.	AV.
1	0.15000	9.82	35.70	22.63	45.52	32.45	66.00	56.00	-20.48	-23.55
2	0.16569	9.82	35.78	20.52	45.60	30.34	65.17	55.17	-19.57	-24.83
3	0.19665	9.83	30.67	15.96	40.50	25.79	63.75	53.75	-23.25	-27.96
4	0.31021	9.86	22.38	8.92	32.24	18.78	59.96	49.96	-27.73	-31.19
5	0.53318	9.89	18.30	11.39	28.19	21.28	56.00	46.00	-27.81	-24.72
6	3.74329	10.11	24.19	13.89	34.30	24.00	56.00	46.00	-21.70	-22.00

Remarks:

1. Q.P. and AV. are abbreviations of quasi-peak and average individually.
2. The emission levels of other frequencies were very low against the limit.
3. Margin value = Emission level – Limit value
4. Correction factor = Insertion loss + Cable loss
5. Emission Level = Correction Factor + Reading Value

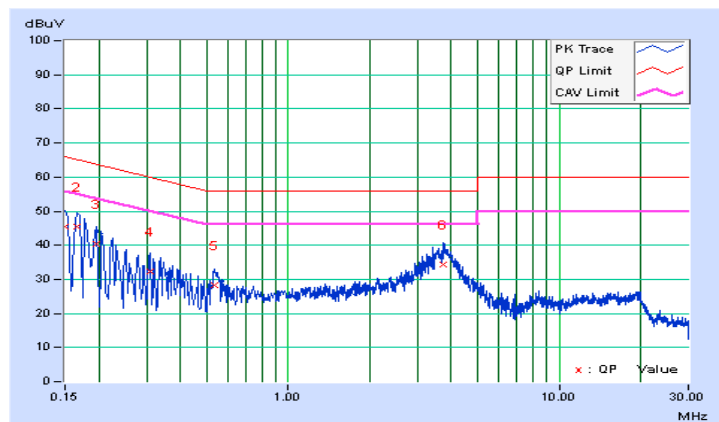

5 Pictures of Test Arrangements

Please refer to the attached file (Test Setup Photo).

Appendix – Information on the Testing Laboratories

We, Bureau Veritas Consumer Products Services (H.K.) Ltd., Taoyuan Branch, were founded in 1988 to provide our best service in EMC, Radio, Telecom and Safety consultation. Our laboratories are accredited and approved according to ISO/IEC 17025.

If you have any comments, please feel free to contact us at the following:

Linko EMC/RF Lab

Tel: 886-2-26052180

Fax: 886-2-26051924

Hsin Chu EMC/RF Lab/Telecom Lab

Tel: 886-3-5935343

Fax: 886-3-5935342

Hwa Ya EMC/RF/Safety

Tel: 886-3-3183232

Fax: 886-3-3270892

Email: service.adt@tw.bureauveritas.com

Web Site: www.bureauveritas-adt.com

The address and road map of all our labs can be found in our web site also.

--- END ---