

## **1CD Installation Manual**

FCC ID of this product is as follows:

FCC ID: VPYLB1CDIMP003.

For OEM integration only – device cannot be sold to the general public. Therefore we will ask OEM to include the following statements required by FCC on the product and in the installation manual notice.

Contents:

1. Land Pattern (Recommended)
2. Chip antenna details
3. Layout Guidelines – chip antenna
4. Antenna circuit schematic – chip antenna
5. PIFA antenna details
6. Layout Guidelines – PIFA antenna
7. Antenna circuit schematic – PIFA antenna
8. 4-layer PCB stackup details – chip antenna & PIFA antenna
9. Test procedure for design verification
10. Production test procedure to ensure compliance
11. FCC & IC statements

# 1. Land Pattern (Recommended)

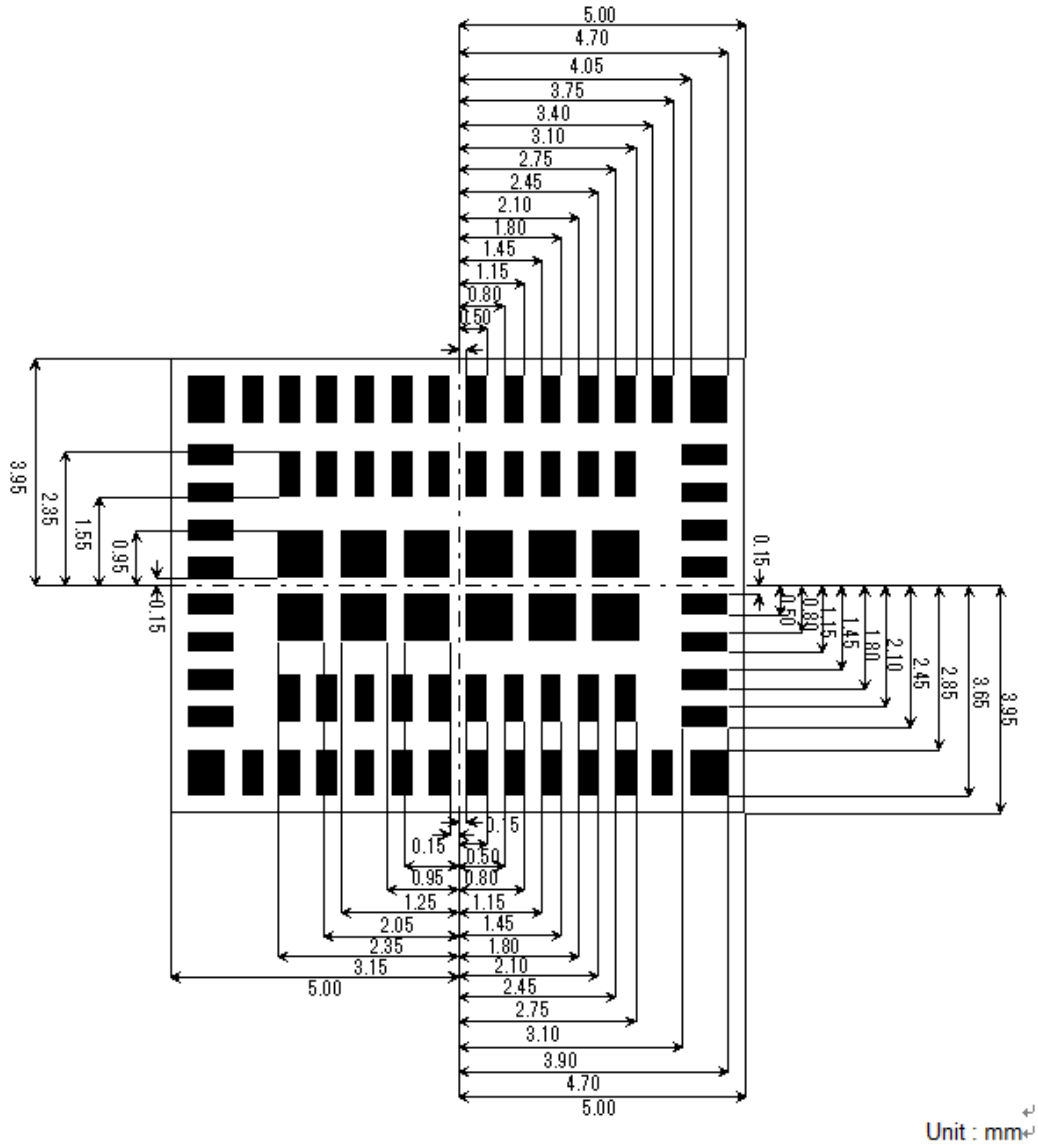

## **2. Chip antenna details**

**The chip antenna is Antenova part number A5839, please refer to Antenova's datasheet for detailed specifications.**

### **3. Layout Guidelines: Chip Antenna**

This section provides required guidelines for PCB designs incorporating the 1CD module.

Figure 1 through Figure 4 show the four-layer 1CD wireless certification board. Refer to Figure 5 through Figure 7 for examples demonstrating good layout practices.

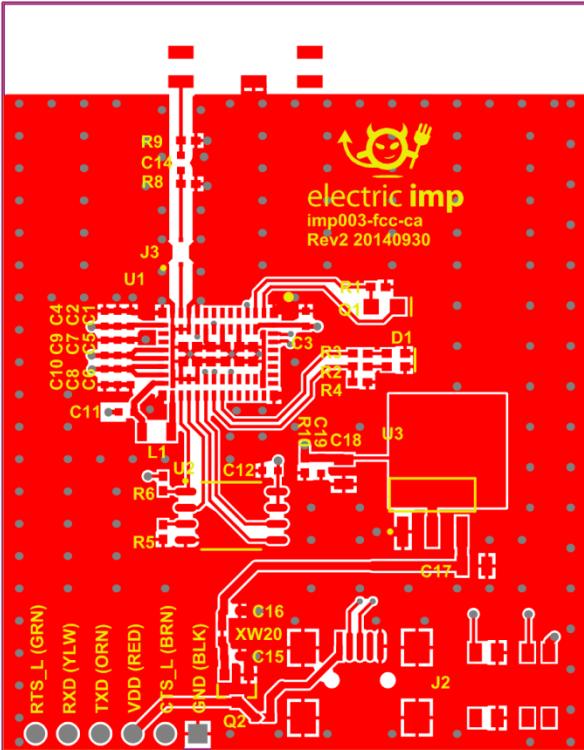

Figure 1: Top Layer

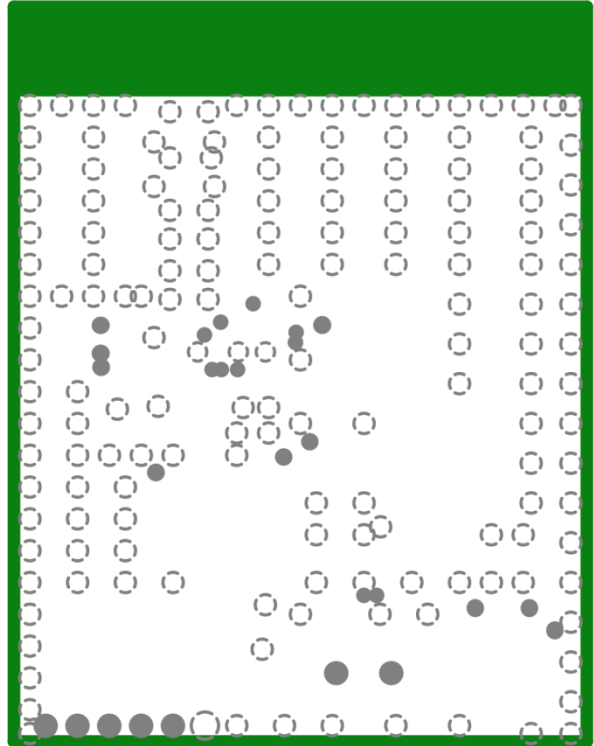

Figure 2: Ground Plane (Layer 2, Negative Image)

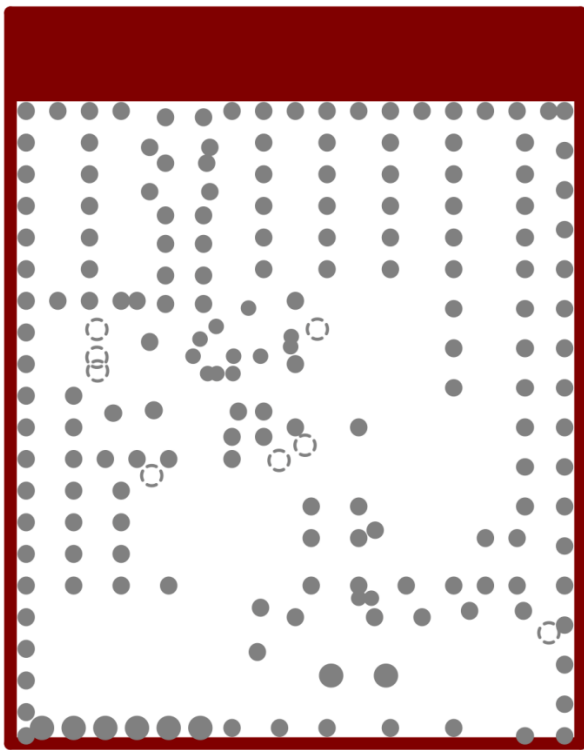

Figure 3: Power Plane (Layer 3, Negative Image)

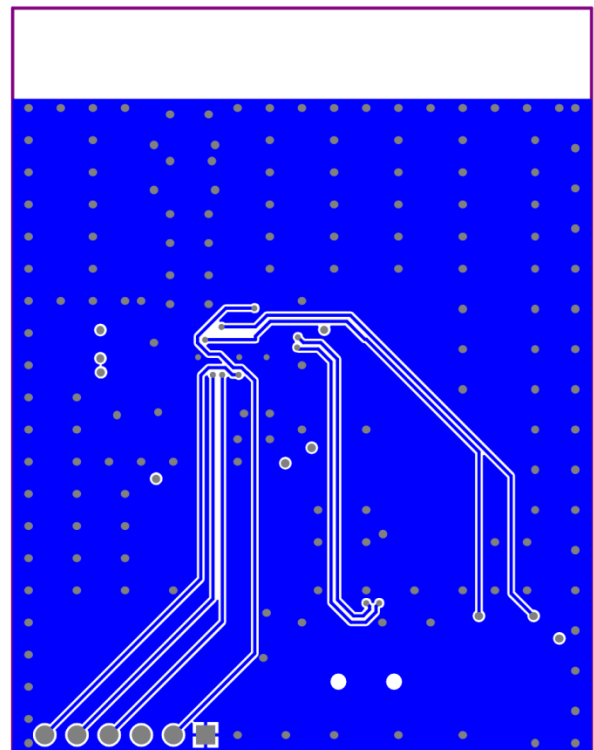
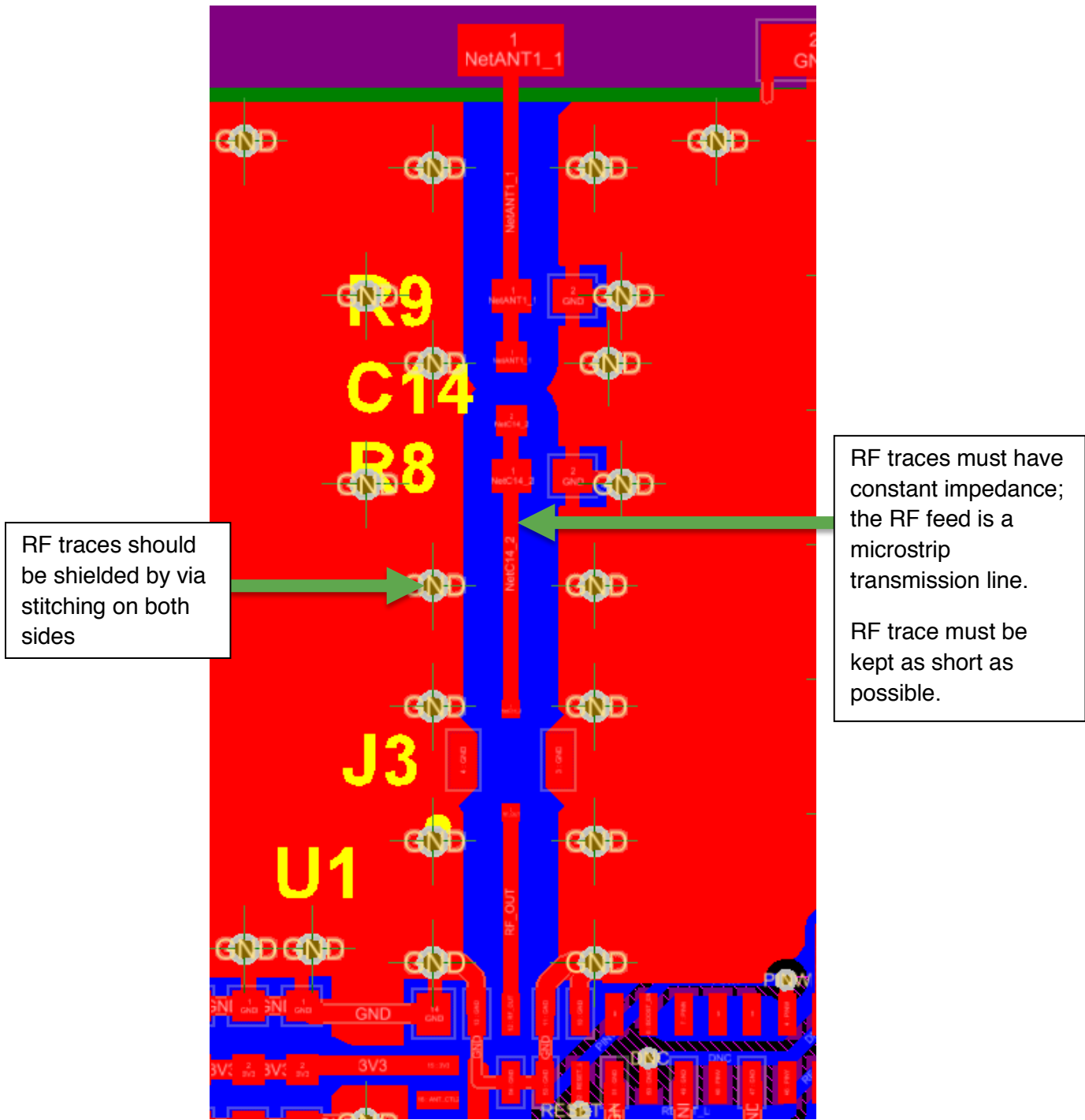

Figure 4: Bottom Layer (Top View)





**Figure 6: RF Trace from Module to Antenna**

Figure 6 shows the entire RF trace, from the 1CD module to the PIFA antenna. The RF trace must be a  $50\Omega \pm 2\Omega$  impedance controlled transmission line which is referenced to a solid, unbroken ground. The trace width and distance to the ground plane must be adjusted to achieve the target impedance. The trace must be shielded by applying stitching vias along the edge of the ground pour on both sides of the RF trace.

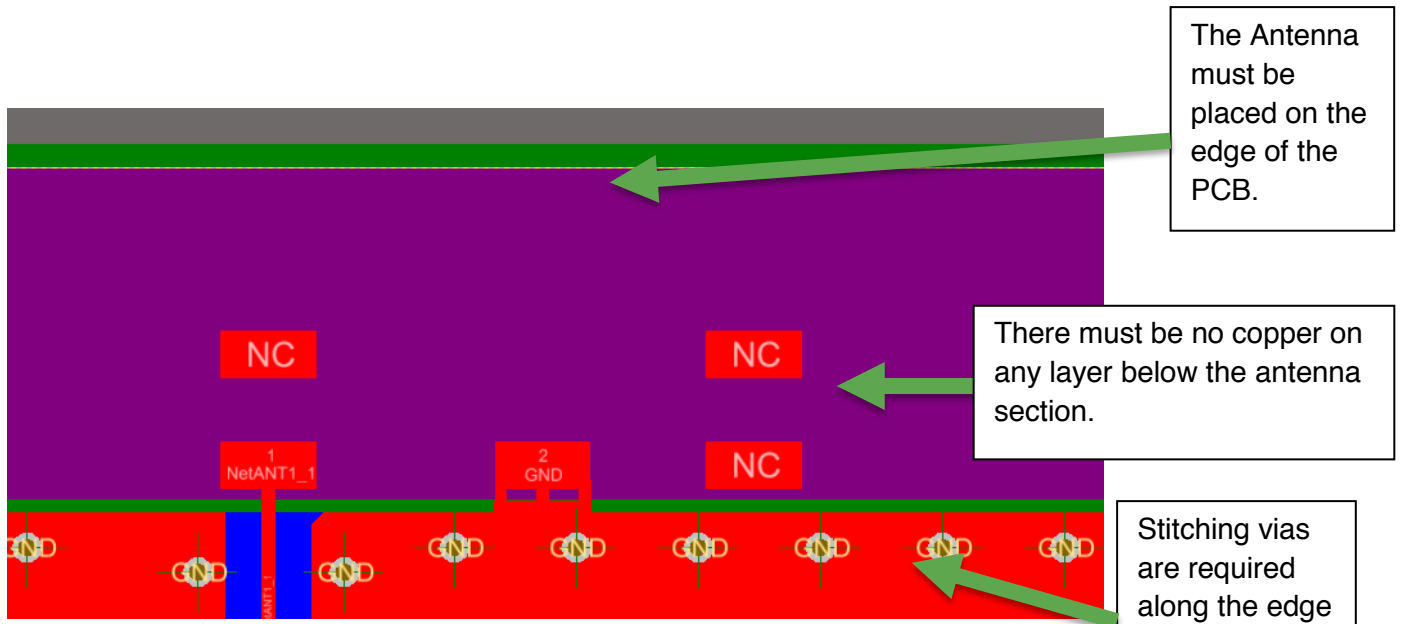
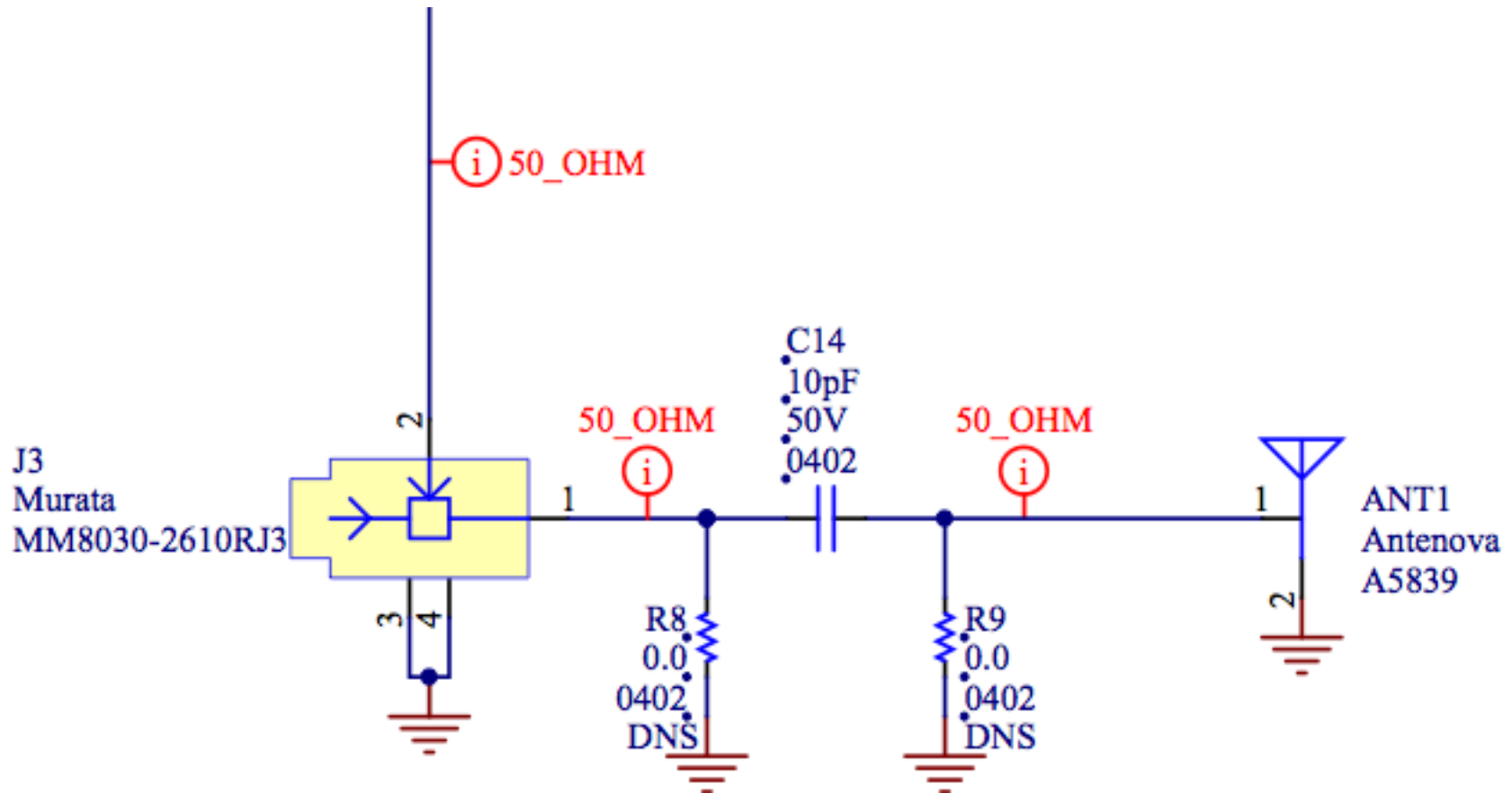

**Figure 7: Antenna and Stitching Vias**

Figure 7 shows the chip antenna. The antenna must be placed at the edge of the PCB, with a copper keep-out under the entire antenna on all PCB layers. No other traces or components may be placed in this region. A row of stitching vias is required along the edge of the ground pour below the antenna section. The module, antenna, and RF Trace must all be placed on the top layer of the board.



#### 4. Antenna circuit schematic - chip antenna (Antenova A5839)



C14 = Cap, C0G, 10pF, +/-0.25pF, 50V, 0402

R8 & R9 = DNS (do not stuff)

## 5. PIFA antenna details

Dimensions in mm

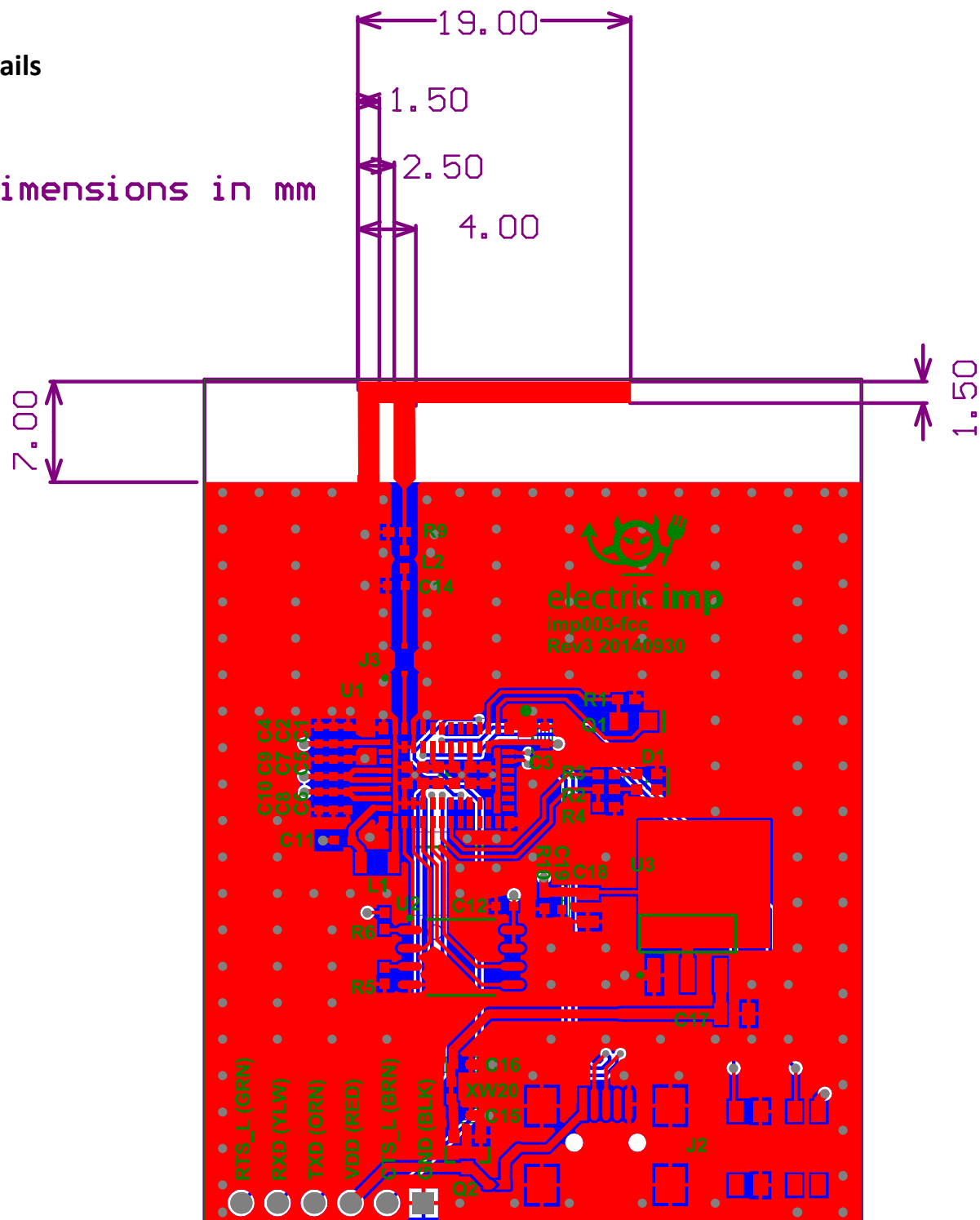

## **6. Layout Guidelines: PIFA Antenna**

This section provides required guidelines for PCB designs incorporating the 1CD module.

Figure 1 through Figure 4 show the four-layer 1CD wireless certification board. Refer to Figure 5 through Figure 7 for examples demonstrating good layout practices.

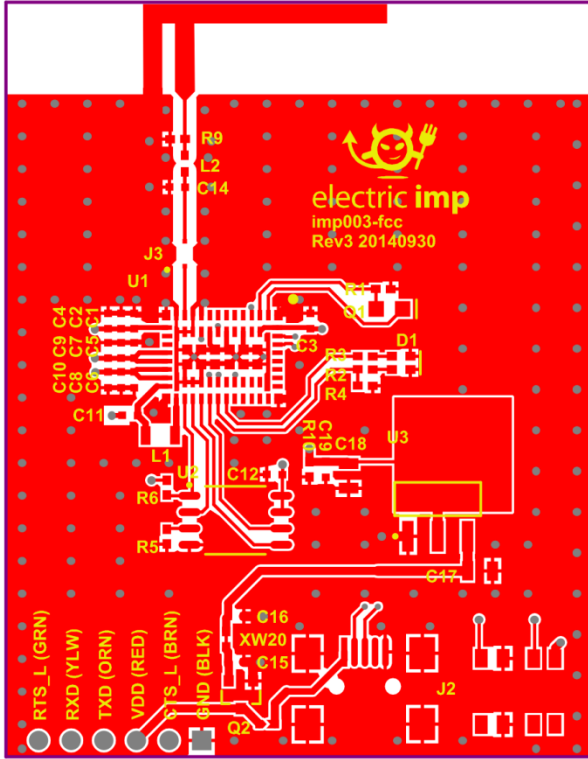

Figure 1: Top Layer

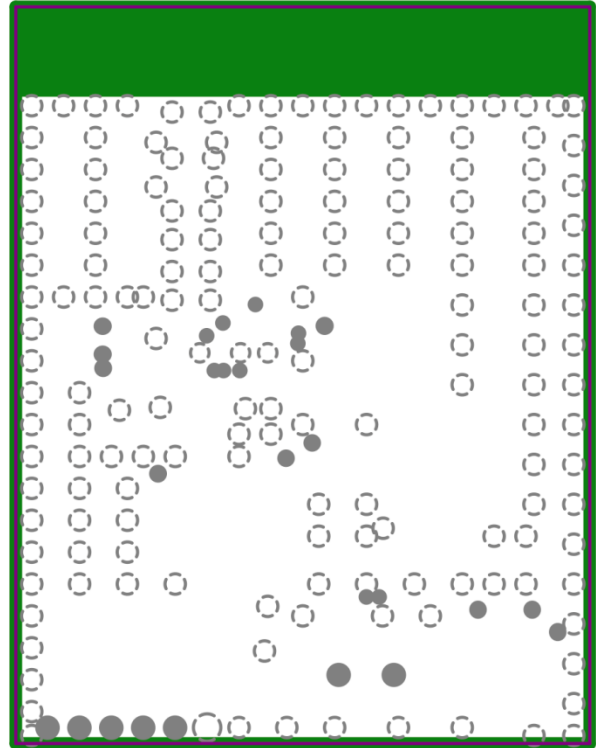

Figure 2: Ground Plane (Layer 2, Negative Image)

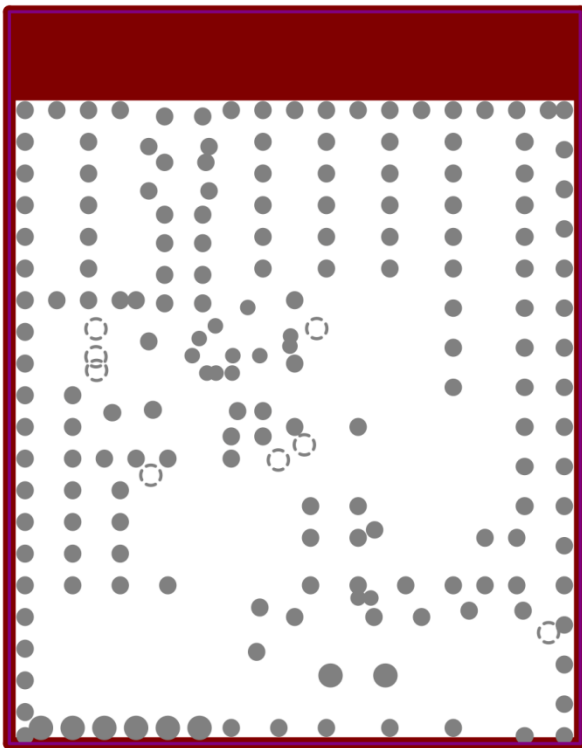

Figure 3: Power Plane (Layer 3, Negative Image)

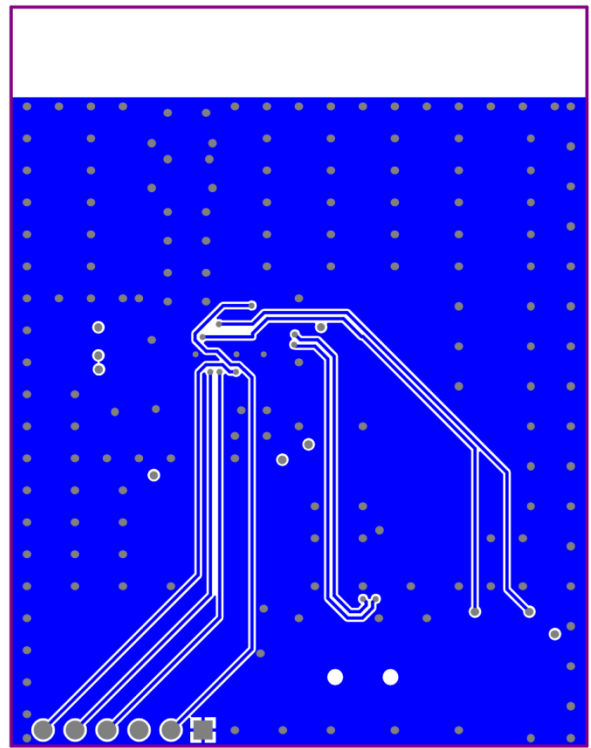
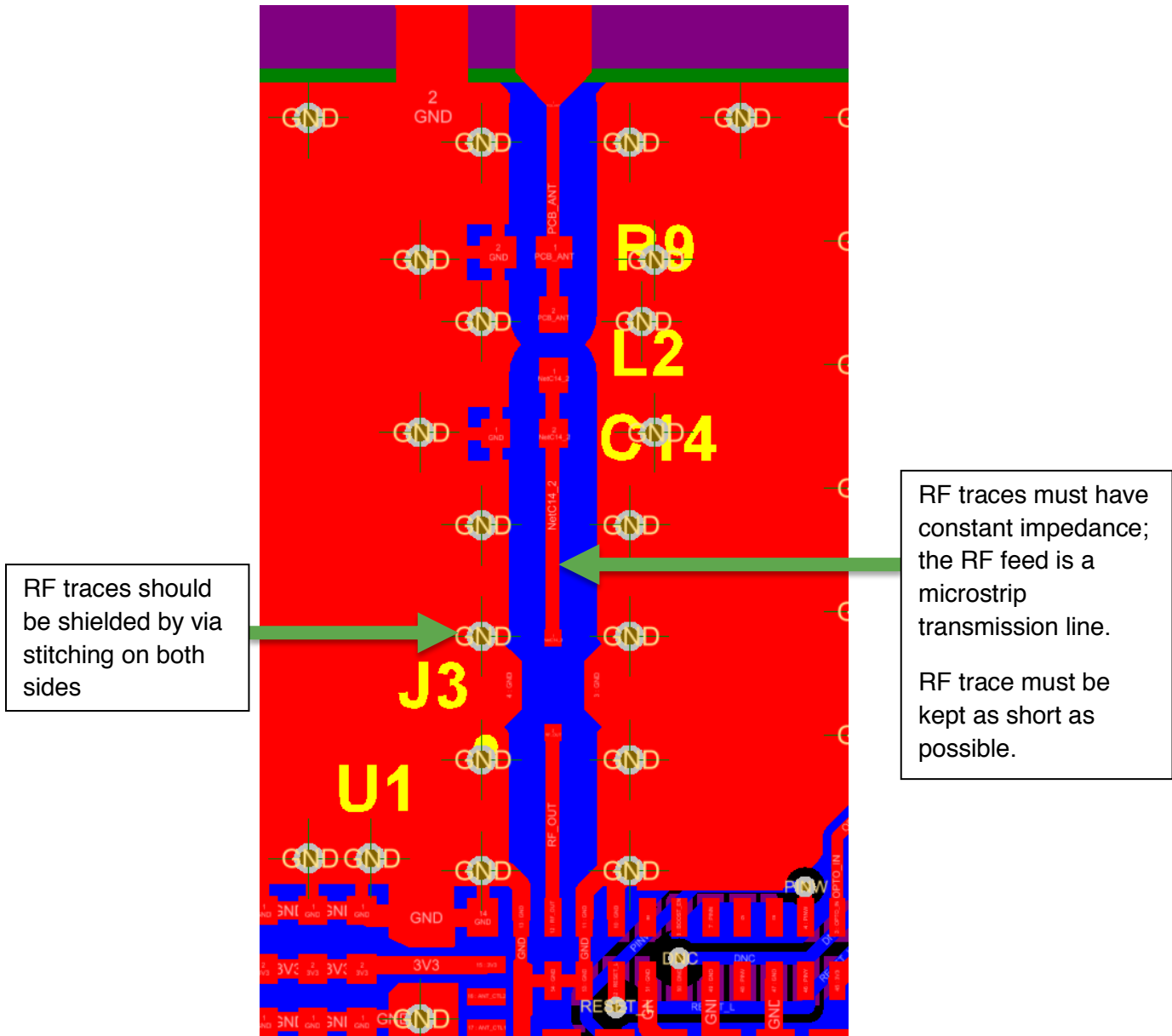

Figure 4: Bottom Layer (Top View)





**Figure 6: RF Trace from Module to Antenna**

Figure 6 shows the entire RF trace, from the 1CD module to the PIFA antenna. The RF trace must be a  $50\Omega \pm 2\Omega$  impedance controlled transmission line which is referenced to a solid, unbroken ground. The trace width and distance to the ground plane must be adjusted to achieve the target impedance. The trace must be shielded by applying stitching vias along the edge of the ground pour on both sides of the RF trace.

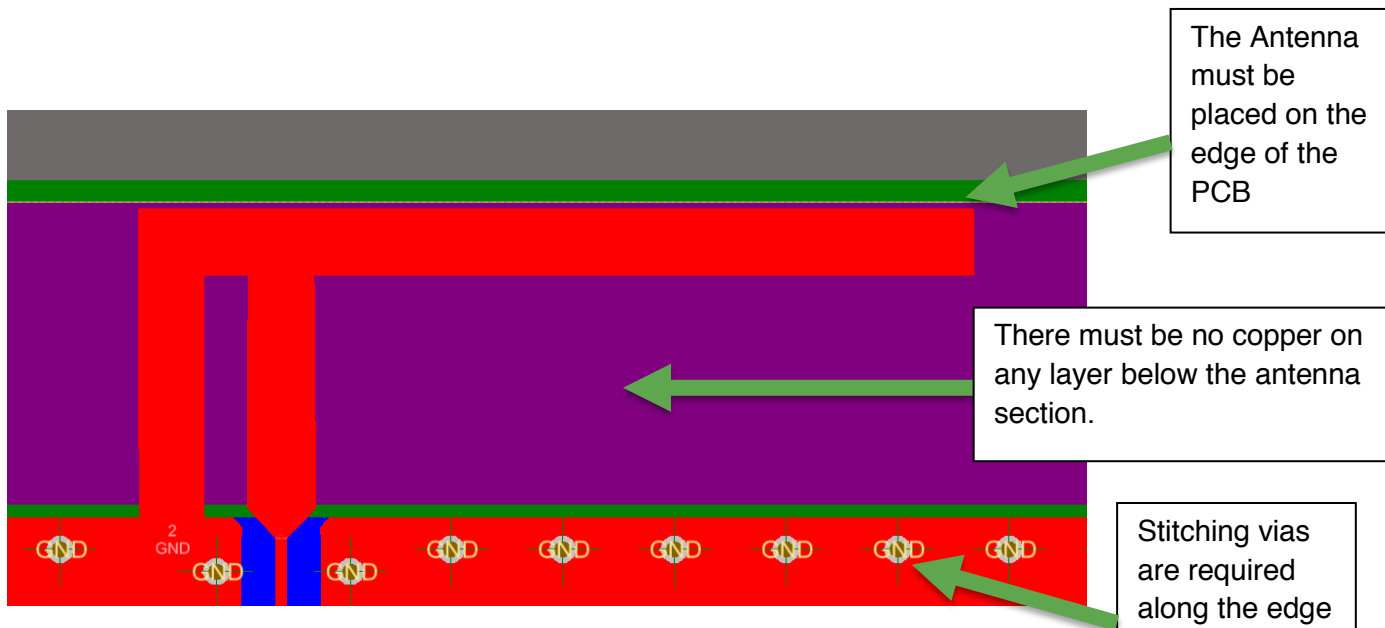

**Figure 7: Antenna and Stitching Vias**

Figure 7 shows the PIFA antenna. The antenna must be placed at the edge of the PCB, with a copper keep-out under the entire antenna element on all PCB layers. No other traces or components may be placed in this region. A row of stitching vias is required along the edge of the ground pour below the antenna section; this ground pour, including the vias, is part of the antenna. The module, antenna, and RF Trace must all be placed on the top layer of the board.

## 7. Antenna circuit schematic - PIFA antenna

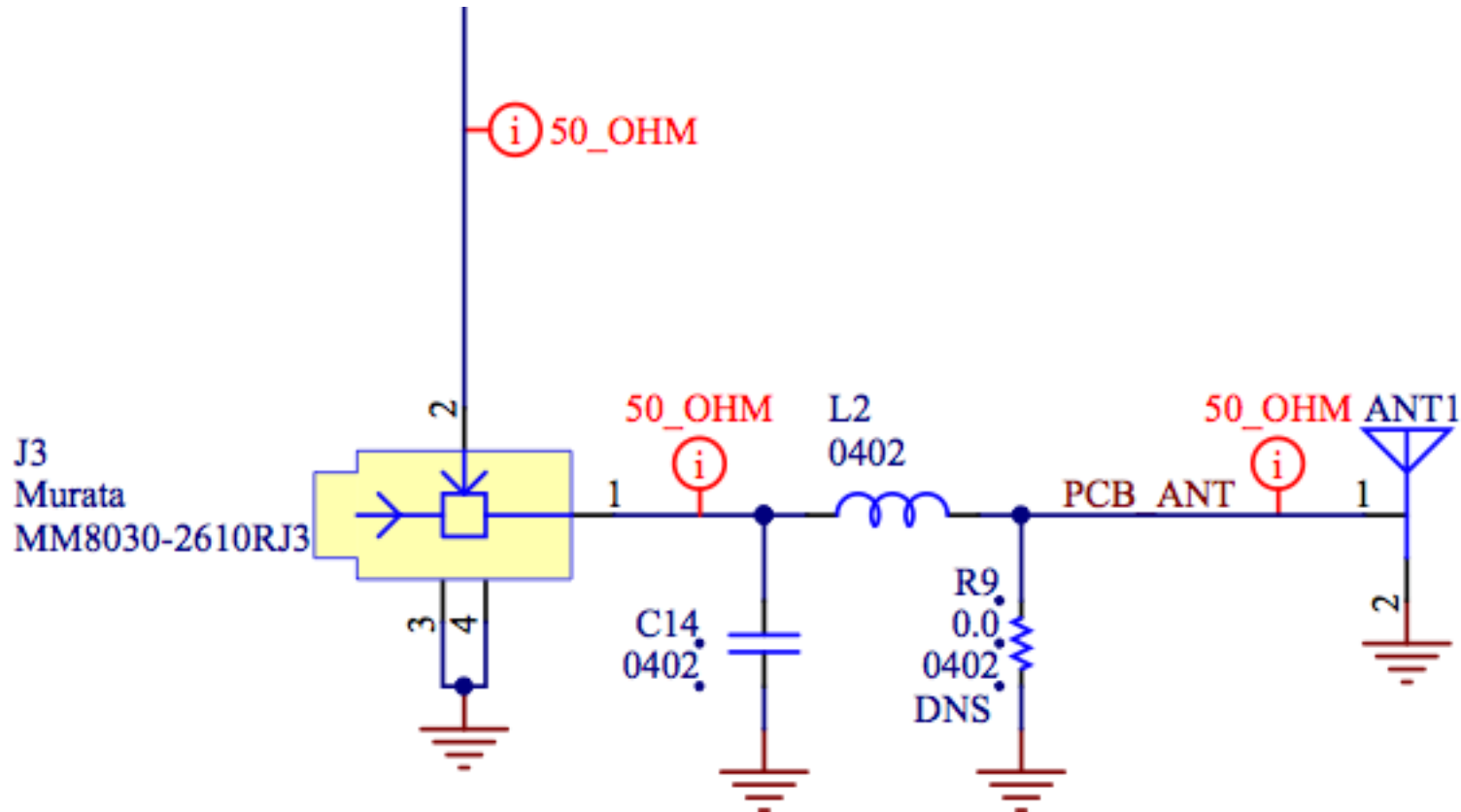

L2 = Ind, 2.4nH, +/- 0.1nH, 300mOhm, 0402 (Recommend Murata LQP15MN2N4B02D)

C14 = DNS(do not stuff)

R9 = DNS (do not stuff)



## 8. 4-layer PCB stackup details - chip antenna & PIFA antenna

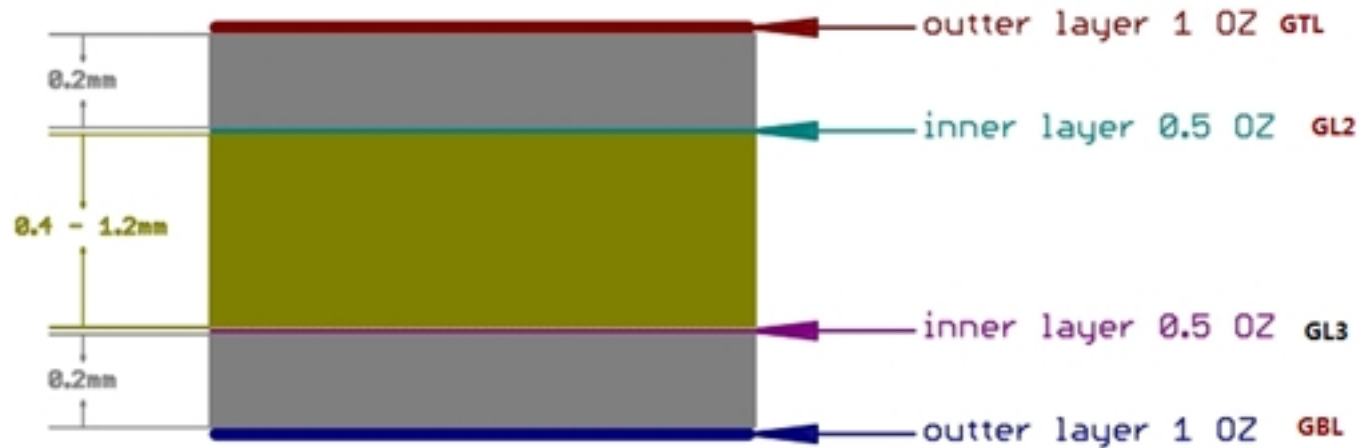

- PCBA PIFA antenna is printed on the GTL layer
  - PIFA finish is ENIG per IPC-4552 with typical thickness range of 0.075um to 0.125um
- GL2 is the ground layer
- GL3 is the power layer
- PCB laminate material is FR4, which has a relative dielectric constant permittivity of 4.70 max., 4.35 @ 500 MHz, 4.34 @ 1 GHz
- PCBA PIFA "thickness" is defined by the copper weight as specified in GTL layer

## **9. Test procedure for design verification**

If the OEM or system integrator incorporates the 1CD module into their final product and wishes to reuse the 1CD module's FCC certification, it is the OEM/system integrator's responsibility to perform necessary design verifications to ensure the antenna design and circuit matches those specified here.

A network analyzer could be used to measure the trace impedance and dimensional measurements could be made of traces to confirm the design was implemented per the specification. Radiated testing at an antenna lab can also be performed to check antenna performance.

## **10. Production test procedures for ensuring compliance**

If the OEM or system integrator incorporates the 1CD module into their final product and wishes to reuse the 1CD module's FCC certification, it is the OEM/system integrator's responsibility to ensure compliance is met on production units.

Incoming inspection of the PCB should be performed to ensure the PCB complies with laminate material spec, 50 Ohm trace impedance spec, PCB stackup spec, antenna dimensional spec and copper weight spec. Post SMT, inspections should be made to ensure the stuffing options per the antenna schematics are followed.

## **FCC Warning**

### Notice

This device complies with Part 15 of the FCC Rules. Operation is subject to the following two conditions: (1) this device may not cause harmful interference and (2) this device must accept any interference received, including interference that may cause undesired operation.

### Information To Be Supplied to the End User by the OEM or Integrator

The following regulatory and safety notices must be published in documentation supplied to the end user of the product or system incorporating an adapter in compliance with local regulations. Host system must be labeled with "Contains FCC ID: VPYLB1CDIMP003.

This 1CD module is to be used only for mobile and fixed application. In order to re-use the 1CD module FCC approvals, the antenna(s) used for this transmitter must be installed to provide a separation distance of at least 20cm from all persons and must not be co-located or operating in conjunction with any other antenna or transmitter. If antenna is installed with a separation distance of less than 20cm from all person or is co-located or operating in conjunction with any other antenna or transmitter then additional FCC testing and certification may be required. End-Users must be provided with transmitter operation conditions for satisfying RF exposure compliance.

OEM integrators must ensure that the end user has no manual instructions to remove or install the 1CD module. Antennas used with the 1CD module must not exceed 2.1dBi gain for chip antennas or 2.24dBi gain for PIFA antennas.

## IC Warning

Canada Low-power license-exempt radio communication devices (RSS-210)

a. Common information Operation is subject to the following two conditions:

1. This device may not cause interference, and
2. This device must accept any interference, including interference that may cause undesired operation of the device.

a. Informations communes

Son fonctionnement est soumis aux deux conditions suivantes:

1. Ce dispositif ne peut causer des interférences, et
2. Ce dispositif doit accepter toute interférence, y compris les interférences qui peuvent causer un mauvais fonctionnement du dispositif.

Information To Be Supplied to the End User by the OEM or Integrator

Modular information form OEM

Information to be Supplied to the End User by the OEM or Integrator

The following regulatory and safety notices must be published in documentation supplied to the end user of the product or system incorporating an adapter in compliance with local regulations.

Host system must be labeled with “Contains IC: 772C-LB1CDIMP003”

This 1CD module is to be used only for mobile and fixed application. In order to re-use the 1CD module IC approvals, the antenna(s) used for this transmitter must be installed to provide a separation distance of at least 20cm from all persons and must not be co-located or operating in conjunction with any other antenna or transmitter. If antenna is installed with a separation distance of less than 20cm from all person or is co-located or operating in conjunction with any other antenna or transmitter then additional IC testing and certification may be required. End-Users must be provided with transmitter operation conditions for satisfying RF exposure compliance.

OEM integrators must ensure that the end user has no manual instructions to remove or install the 1CD module. Antennas used with the 1CD module must not exceed 2.1dBi gain for chip antennas or 2.24dBi gain for PIFA antennas.