



RADIO TEST REPORT

Test Report No. : 11119465H-A-R1

Applicant : Murata Manufacturing Co., Ltd.
Type of Equipment : Communication Module
Model No. : 1CA
FCC ID : VPYLB1CA
Test regulation : FCC Part 15 Subpart C: 2015
Test Result : Complied

1. This test report shall not be reproduced in full or partial, without the written approval of UL Japan, Inc.
2. The results in this report apply only to the sample tested.
3. This sample tested is in compliance with the above regulation.
4. The test results in this report are traceable to the national or international standards.
5. This test report must not be used by the customer to claim product certification, approval, or endorsement by NVLAP, NIST, or any agency of the Federal Government.
6. This test report covers Radio technical requirements. It does not cover administrative issues such as Manual or non-Radio test related Requirements. (if applicable)
7. This report is a revised version of 11119465H-A. 11119465H-A is replaced with this report.

Date of test: January 9 to 11, 2016

Representative test engineer:

Shimichi Miyazono
Engineer
Consumer Technology Division

Approved by:

Takayuki Shimada
Engineer
Consumer Technology Division



NVLAP LAB CODE: 200572-0

This laboratory is accredited by the NVLAP LAB CODE 200572-0, U.S.A. The tests reported herein have been performed in accordance with its terms of accreditation.
*As for the range of Accreditation in NVLAP, you may refer to the WEB address,
http://japan.ul.com/resources/emc_accredited/

UL Japan, Inc.

Ise EMC Lab.

4383-326 Asama-cho, Ise-shi, Mie-ken 516-0021 JAPAN

Telephone : +81 596 24 8999

Facsimile : +81 596 24 8124

13-EM-F0429

CONTENTS	PAGE
SECTION 1: Customer information.....	4
SECTION 2: Equipment under test (E.U.T.).....	4
SECTION 3: Test specification, procedures & results.....	5
SECTION 4: Operation of E.U.T. during testing.....	8
SECTION 5: Conducted Emission.....	11
SECTION 6: Radiated Spurious Emission	12
SECTION 7: Antenna Terminal Conducted Tests.....	14
APPENDIX 1: Test data	15
Conducted Emission	15
6dB Bandwidth	16
Maximum Peak Output Power	19
Average Output Power.....	22
Radiated Spurious Emission	24
Conducted Spurious Emission	39
Power Density	40
99% Occupied Bandwidth	43
APPENDIX 2: Test instruments	45
APPENDIX 3: Photographs of test setup	46
Conducted Emission	46
Radiated Spurious Emission	47
Worst Case Position (Horizontal: Z-axis/ Vertical: Y-axis)	48

SECTION 1: Customer information

Company Name : Murata Manufacturing Co., Ltd.
Address : 1-10-1 Higashikotari, Nagaokakyo-shi, Kyoto 617-8555 Japan
Telephone Number : +81-75-955-6736
Facsimile Number : +81-75-955-6634
Contact Person : Motoo Hayashi

SECTION 2: Equipment under test (E.U.T.)

2.1 Identification of E.U.T.

Type of Equipment : Communication Module
Model No. : 1CA
Serial No. : Refer to Section 4, Clause 4.2
Rating : VDD Typ. 3.3V, Min. 3.0V, Max. 3.6V
VIO1 Typ. 3.3V, Min. 3.0V, Max. 3.6V
VIO2 Typ. 3.3V, Min. 3.0V, Max. 3.6V
(VIO1 and VIO2 don't influence the RF Characteristic.)
Receipt Date of Sample : January 7, 2016
Country of Mass-production : China
Condition of EUT : Engineering prototype
(Not for Sale: This sample is equivalent to mass-produced items.)
Modification of EUT : No Modification by the test lab

2.2 Product Description

Model: 1CA (referred to as the EUT in this report) is a Communication Module.

General Specification

Clock frequency(ies) in the system : 20 MHz

Specification of WLAN (IEEE802.11b/g/n)

Type of radio	Wireless LAN (IEEE802.11b/g)	Wireless LAN (IEEE802.11n) 2.4G Band SISO (20M Band)
Equipment Type	Transceiver	
Frequency of Operation	2412MHz - 2462MHz	
Bandwidth & Channel spacing	Bandwidth : 20MHz Ch spacing : 5MHz	
Type of Modulation	11b: DSSS 11g: OFDM	OFDM
Antenna Type / Antenna Gain	Monopole Pattern Antenna: 1.9dBi	
Power Supply (inner)	DC 3.3V	
Operating temperature range	0 to +80 deg. C	

UL Japan, Inc.

Ise EMC Lab.

4383-326 Asama-cho, Ise-shi, Mie-ken 516-0021 JAPAN

Telephone : +81 596 24 8999

Facsimile : +81 596 24 8124

SECTION 3: Test specification, procedures & results

3.1 Test Specification

Test Specification : FCC Part 15 Subpart C: 2015, final revised on November 23, 2015
*Some parts are effective on and after December 17, 2015 or December 23, 2015. The revision does not affect the test specification applied to the EUT.

Title : FCC 47CFR Part15 Radio Frequency Device Subpart C Intentional Radiators
Section 15.207 Conducted limits
Section 15.247 Operation within the bands 902-928MHz,
2400-2483.5MHz, and 5725-5850MHz

3.2 Procedures and results

Item	Test Procedure	Specification	Worst margin	Results	Remarks
Conducted Emission	FCC: ANSI C63.10-2013 6. Standard test methods ----- IC: RSS-Gen 8.8	FCC: Section 15.207 ----- IC: RSS-Gen 8.8	QP 12.5 dB, 8.05140 MHz, L 12.5 dB, 8.05160 MHz, N AV 6.2 dB, 8.64150 MHz, N	Complied	-
6dB Bandwidth	FCC: KDB 558074 D01 DTS Meas Guidance v03r04 ----- IC: -	FCC: Section 15.247(a)(2) ----- IC: RSS-247 5.2(1)	See data.	Complied	Conducted
Maximum Peak Output Power	FCC: KDB 558074 D01 DTS Meas Guidance v03r04 ----- IC: RSS-Gen 6.12	FCC: Section 15.247(b)(3) ----- IC: RSS-247 5.4(4)		Complied	Conducted
Power Density	FCC: KDB 558074 D01 DTS Meas Guidance v03r04 ----- IC: -	FCC: Section 15.247(e) ----- IC: RSS-247 5.2(2)		Complied	Conducted
Spurious Emission Restricted Band Edges	FCC: KDB 558074 D01 DTS Meas Guidance v03r04 ----- IC: RSS-Gen 6.13	FCC: Section15.247(d) ----- IC: RSS-247 5.5 RSS-Gen 8.9 RSS-Gen 8.10	0.3 dB 2390.000 MHz, AV, Horizontal.	Complied	Conducted (below 30 MHz)/ Radiated (above 30 MHz) *1)

Note: UL Japan, Inc.'s EMI Work Procedures No. 13-EM-W0420 and 13-EM-W0422.

*1) Radiated test was selected over 30 MHz based on section 15.247(d) and KDB 558074 D01 DTS Meas Guidance v03r04 12.2.7.

* In case any questions arise about test procedure, ANSI C63.10: 2013 is also referred.

FCC 15.31 (e)

The EUT has the power supply regulator. However one of the input voltages to RF part doesn't go through the regulator. The stable voltage will be supplied by the end product, which will be required to have a power supply regulator. Therefore, the EUT complies with the requirement.

FCC Part 15.203/212 Antenna requirement

The antenna is not removable from the EUT. Therefore, the equipment complies with the antenna requirement of Section 15.203/212.

3.3 Addition to standard

Item	Test Procedure	Specification	Worst margin	Results	Remarks
99% Occupied Bandwidth	IC: RSS-Gen 6.6	IC: -	N/A	-	Conducted

Other than above, no addition, exclusion nor deviation has been made from the standard.

UL Japan, Inc.

Ise EMC Lab.

4383-326 Asama-cho, Ise-shi, Mie-ken 516-0021 JAPAN

Telephone : +81 596 24 8999

Facsimile : +81 596 24 8124

3.4 Uncertainty

EMI

The following uncertainties have been calculated to provide a confidence level of 95 % using a coverage factor $k = 2$.
Ise EMC Lab.

Antenna terminal test Uncertainty (+/-)							
Power meter		Conducted emission and Power density			Conducted emission		Channel power
Below 1 GHz	Above 1 GHz	Below 1 GHz	1 GHz - 3 GHz	3 GHz - 26.5 GHz	18 GHz - 26.5 GHz	26.5 GHz - 40 GHz	
0.9 dB	1.0 dB	1.4 dB	1.7 dB	2.8 dB	2.8 dB	2.9 dB	

Frequency range	Conducted emission using AMN(LISN) (+dB)
0.009 – 0.15MHz	3.5 dB
0.15 – 30MHz	2.9 dB

Polarity	Radiated emission (Below 1GHz)			
	(3 m*)(+dB)		(10 m*)(+dB)	
	30 – 300 MHz	300 – 1000MHz	30 – 300 MHz	300 – 1000MHz
Horizontal	4.8 dB	5.2 dB	4.8 dB	5.0 dB
Vertical	4.5 dB	5.9 dB	4.8 dB	5.1 dB

Radiated emission				
(3 m*)(+dB)		(1 m*)(+dB)	(0.5 m*)(+dB)	(10 m*)(+dB)
1 – 6GHz	6 – 18GHz	10 – 26.5 GHz	26.5 – 40GHz	1 - 18 GHz
5.1 dB	5.3 dB	5.1 dB	5.1 dB	5.3 dB

*Measurement distance

Conducted Emission test

The data listed in this test report has enough margin, more than the site margin.

Radiated emission test

The data listed in this report meets the limits unless the uncertainty is taken into consideration.

3.5 Test Location

UL Japan, Inc. Ise EMC Lab. *NVLAP Lab. code: 200572-0
 4383-326 Asama-cho, Ise-shi, Mie-ken 516-0021 JAPAN
 Telephone: +81 596 24 8999, Facsimile: +81 596 24 8124

Test site	IC Registration Number	Width x Depth x Height (m)	Size of reference ground plane (m) / horizontal conducting plane	Other rooms	Maximum measurement distance
No.1 semi-anechoic chamber	2973C-1	19.2 x 11.2 x 7.7	7.0 x 6.0	No.1 Power source room	10 m
No.2 semi-anechoic chamber	2973C-2	7.5 x 5.8 x 5.2	4.0 x 4.0	-	3 m
No.3 semi-anechoic chamber	2973C-3	12.0 x 8.5 x 5.9	6.8 x 5.75	No.3 Preparation room	3 m
No.3 shielded room	-	4.0 x 6.0 x 2.7	N/A	-	-
No.4 semi-anechoic chamber	2973C-4	12.0 x 8.5 x 5.9	6.8 x 5.75	No.4 Preparation room	3 m
No.4 shielded room	-	4.0 x 6.0 x 2.7	N/A	-	-
No.5 semi-anechoic chamber	-	6.0 x 6.0 x 3.9	6.0 x 6.0	-	-
No.6 shielded room	-	4.0 x 4.5 x 2.7	4.0 x 4.5	-	-
No.6 measurement room	-	4.75 x 5.4 x 3.0	4.75 x 4.15	-	-
No.7 shielded room	-	4.7 x 7.5 x 2.7	4.7 x 7.5	-	-
No.8 measurement room	-	3.1 x 5.0 x 2.7	N/A	-	-
No.9 measurement room	-	8.8 x 4.6 x 2.8	2.4 x 2.4	-	-
No.11 measurement room	-	6.2 x 4.7 x 3.0	4.8 x 4.6	-	-

* Size of vertical conducting plane (for Conducted Emission test) : 2.0 m x 2.0m for No.1, No.2, No.3, and No.4 semi-anechoic chambers and No.3 and No.4 shielded rooms.

3.6 Test data, Test instruments, and Test set up

Refer to APPENDIX.

SECTION 4: Operation of E.U.T. during testing

4.1 Operating Mode(s)

Test operating mode was determined as follows according to “Section 1 of 6 802.11 a/b/g/n testing - Managing Complex Regulatory Approvals - ” of TCB Council Workshop October 2009.

Mode	Remarks*
IEEE 802.11b (11b)	11 Mbps, PN9
IEEE 802.11g (11g)	9 Mbps, PN9
IEEE 802.11n SISO 20 MHz BW (11n-20)	MCS 5 PN9
*The worst condition was determined based on the test result of Maximum Peak Output Power (Mid Channel)	
*Power of the EUT was set by the software as follows; Power settings: 11b: 15.5dBm, 11g: 13dBm, 11n-20: 13dBm Software: 1.42 RC0.0/ 6.10.198.69 *This setting of software is the worst case. Any conditions under the normal use do not exceed the condition of setting. In addition, end users cannot change the settings of the output power of the product.	

*The details of Operating mode(s)

Test Item	Operating Mode	Tested frequency
Conducted Emission Spurious Emission (Conducted)	11g Tx *1)	2437MHz *1)
Spurious Emission (Radiated)	11b Tx 11g Tx	2412MHz 2437MHz 2462MHz
	11n-20 Tx *2)	2412MHz 2462MHz
6dB Bandwidth, Maximum Peak Output Power, Power Density, 99% Occupied Bandwidth	11b Tx 11g Tx 11n-20 Tx	2412MHz 2437MHz 2462MHz
*1) The test was performed on the representative mode/frequency that had the highest power at antenna terminal test. *2) Only band edge was tested on this mode according to “Section 1 of 6 802.11 a/b/g/n testing- Managing Complex Regulatory Approvals - ” of TCB Council Workshop October 2009, as the 11g Tx mode had the higher power at antenna terminal test.		

4.2 Configuration and peripherals

Conducted Emission

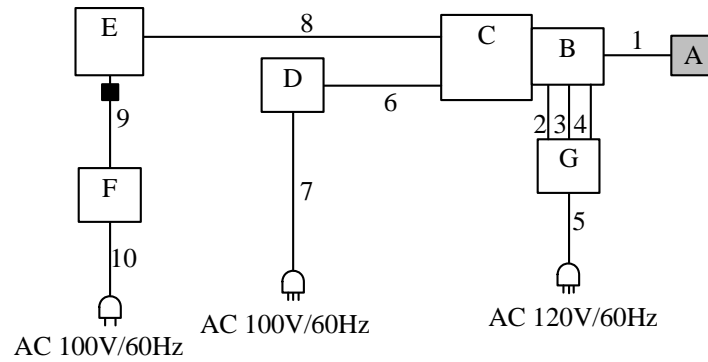

Radiated Emission

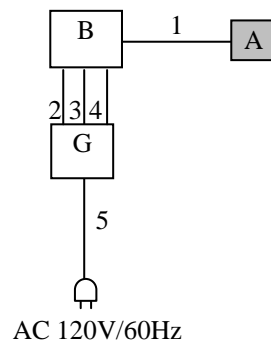

* Cabling and setup(s) were taken into consideration and test data was taken under worse case conditions.

Description of EUT

No.	Item	Model number	Serial number	Manufacturer	Remarks
A	Communication Module	1CA	3	Murata Manufacturing Company, Ltd.	EUT
B	Jig	-	-	Murata Manufacturing Company, Ltd.	-
C	Jig	-	-	Murata Manufacturing Company, Ltd.	-
D	DC Power Supply	PW8-3ATP	09067054	KENWOOD	for Jig
E	Laptop PC	2522-C49	R8-D76YV11/01	lenovo	-
F	AC Adapter	42T4418	11S42T4418ZIZGW G24RHH1	lenovo	-
G	DC Power Supply	PMG35-2A	13090501	KIKUSUI	for EUT

List of cables used

No.	Name	Length (m)	Shield		Remarks
			Cable	Connector	
1	Signal Cable	0.1	Unshielded	Unshielded	-
2	DC Cable	1.0	Unshielded	Unshielded	-
3	DC Cable	1.0	Unshielded	Unshielded	-
4	DC Cable	1.0	Unshielded	Unshielded	-
5	AC Cable	2.0	Unshielded	Unshielded	-
6	DC Cable	3.0	Unshielded	Unshielded	-
7	AC Cable	2.0	Unshielded	Unshielded	-
8	RS-232C Cable	2.5	Shielded	Shielded	-
9	DC Cable	1.8	Unshielded	Unshielded	-
10	AC Cable	1.0	Unshielded	Unshielded	-

UL Japan, Inc.

Ise EMC Lab.

4383-326 Asama-cho, Ise-shi, Mie-ken 516-0021 JAPAN

Telephone : +81 596 24 8999

Facsimile : +81 596 24 8124

SECTION 5: Conducted Emission

Test Procedure and conditions

EUT was placed on a urethane platform of nominal size, 1.0 m by 1.5 m, raised 0.8 m above the conducting ground plane.

The rear of tabletop was located 40 cm to the vertical conducting plane. The rear of EUT, including peripherals aligned and flushed with rear of tabletop. All other surfaces of tabletop were at least 80cm from any other grounded conducting surface. EUT was located 80 cm from a Line Impedance Stabilization Network (LISN) / Artificial mains Network (AMN) and excess AC cable was bundled in center.

1) For the tests on EUT with other peripherals (as a whole system)

I/O cables that were connected to the peripherals were bundled in center. They were folded back and forth forming a bundle 30 cm to 40 cm long and were hanged at a 40 cm height to the ground plane. All unused 50ohm connectors of the LISN (AMN) were resistivity terminated in 50 ohm when not connected to the measuring equipment.

The AC Mains Terminal Continuous disturbance Voltage has been measured with the EUT in a Semi Anechoic Chamber.

The EUT was connected to a LISN (AMN).

An overview sweep with peak detection has been performed.

The test results and limit are rounded off to one decimal place, so some differences might be observed.

Detector : QP and CISPR AV
Measurement range : 0.15 MHz – 30 MHz
Test data : APPENDIX
Test result : Pass

SECTION 6: Radiated Spurious Emission

Test Procedure

It was measured based on "11.0 Emissions in non-restricted frequency bands" of "558074 D01 DTS Meas Guidance v03r04".

[For below 1GHz]

EUT was placed on a urethane platform of nominal size, 0.5 m by 1.0 m, raised 0.8 m above the conducting ground plane. The Radiated Electric Field Strength has been measured in a Semi Anechoic Chamber with a ground plane.

[For above 1GHz]

EUT was placed on a urethane platform of nominal size, 0.5 m by 1.0 m, raised 1.5 m above the conducting ground plane.

The Radiated Electric Field Strength has been measured in a Semi Anechoic Chamber with absorbent materials lined on a ground plane.

The height of the measuring antenna varied between 1 and 4 m and EUT was rotated a full revolution in order to obtain the maximum value of the electric field strength.

The measurements were performed for both vertical and horizontal antenna polarization with the Test Receiver, or the Spectrum Analyzer.

The measurements were made with the following detector function of the test receiver and the Spectrum analyzer (in linear mode).

The test was made with the detector (RBW/VBW) in the following table.

When using Spectrum analyzer, the test was made with adjusting span to zero by using peak hold.

Test Antennas are used as below;

Frequency	30 MHz to 300 MHz	300 MHz to 1 GHz	Above 1 GHz
Antenna Type	Biconical	Logperiodic	Horn

In any 100 kHz bandwidth outside the restricted band in which the spread spectrum intentional radiator is operating, the radio frequency power that is produced by the intentional radiator confirmed 20 dB below that in the 100 kHz bandwidth within the band that contains the highest level of the desired power, based on a radiated measurement.

20dBc was applied to the frequency over the limit of FCC 15.209 / Table 4 of RSS-Gen 8.9(IC) and outside the restricted band of FCC15.205 / Table 6 of RSS-Gen 8.10 (IC).

Frequency	Below 1GHz	Above 1GHz		20dBc
Instrument used	Test Receiver	Spectrum Analyzer		Spectrum Analyzer
Detector	QP	PK	AV *1)	PK
IF Bandwidth	BW 120kHz	RBW: 1MHz VBW: 3MHz	Average Power Method: <u>WLAN: 12.2.5.1 (11b/g)</u> RBW: 1MHz VBW: 3MHz Detector: Power Averaging (RMS) Trace: Free Run <u>WLAN: 12.2.5.2 (11n-20)</u> RBW: 1MHz VBW: 3MHz Detector: Power Averaging (RMS) Trace: Free Run Duty factor was added to the results. Integration Method: <u>13.3.1 (11b/g)</u> RBW: 100kHz VBW: 300kHz Span: 2MHz Band Power: 1MHz Detector: Power Averaging (RMS) Trace: 100 traces <u>13.3.2 (11n-20)</u> RBW: 100kHz VBW: 300kHz Span: 2MHz Band Power: 1MHz Detector: Power Averaging (RMS) Trace: 100 traces Duty factor was added to the results.	RBW: 100kHz VBW: 300kHz
Test Distance	3m	4.5m *2) (below 10GHz), 1m *3) (above 10GHz)		4.5m *2) (below 10GHz), 1m *3) (above 10GHz)

*1) Average Power Measurement was performed based on 6.0 & 12.2.5 of "558074 D01 DTS Meas Guidance v03r04 (Issued on January 7, 2016)"

*2) Distance Factor: $20 \times \log(4.5\text{m}/3.0\text{m}) = 3.5\text{dB}$

*3) Distance Factor: $20 \times \log(1.0\text{m} / 3.0\text{m}) = -9.5\text{dB}$

- The carrier level and noise levels were confirmed at each position of X, Y and Z axes of EUT to see the position of maximum noise, and the test was made at the position that has the maximum noise.

The test results and limit are rounded off to one decimal place, so some differences might be observed.

Measurement range : 30M-26.5GHz
Test data : APPENDIX
Test result : Pass

UL Japan, Inc.

Ise EMC Lab.

4383-326 Asama-cho, Ise-shi, Mie-ken 516-0021 JAPAN

Telephone : +81 596 24 8999

Facsimile : +81 596 24 8124

SECTION 7: Antenna Terminal Conducted Tests

Test Procedure

The tests were made with below setting connected to the antenna port.

Test	Span	RBW	VBW	Sweep time	Detector	Trace	Instrument used
6dB Bandwidth	20 MHz	100 kHz	300 kHz	Auto	Peak	Max Hold	Spectrum Analyzer
99% Occupied Bandwidth *1)	Enough width to display emission skirts	1 to 5 % of OBW	Three times of RBW	Auto	Peak	Max Hold	Spectrum Analyzer
Maximum Peak Output Power	-	-	-	Auto	Peak/ Average *2)	-	Power Meter (Sensor: 80 MHz BW)
Peak Power Density	1.5 times the 6dB Bandwidth	3 kHz	10 kHz	Auto	Peak	Max Hold	Spectrum Analyzer *3)
Conducted Spurious Emission *4)	9kHz to 150kHz	200 Hz	620 Hz	Auto	Peak	Max Hold	Spectrum Analyzer
	150kHz to 30MHz	9.1 kHz	27 kHz				

*1) Peak hold was applied as Worst-case measurement.

*2) Reference data

*3) Section 10.2 Method PKPSD (peak PSD) of "KDB 558074 D01 DTS Meas Guidance v03r04".

*4) In the frequency range below 30MHz, RBW was narrowed to separate the noise contents.

Then, wide-band noise near the limit was checked separately, however the noise was not detected as shown in the chart.
(9 kHz - 150 kHz: RBW = 200 Hz, 150 kHz - 30 MHz: RBW = 9.1 kHz)

The test results and limit are rounded off to two decimals place, so some differences might be observed.

Test data : APPENDIX
Test result : Pass

UL Japan, Inc.

Ise EMC Lab.

4383-326 Asama-cho, Ise-shi, Mie-ken 516-0021 JAPAN

Telephone : +81 596 24 8999

Facsimile : +81 596 24 8124

APPENDIX 1: Test data

Conducted Emission

DATA OF CONDUCTED EMISSION TEST

UL Japan, Inc. Ise EMC Lab. No.3 Semi Anechoic Chamber
 Date : 2016/01/10

Report No. : 11119465H
 Temp./Humi. : 22deg. C / 32% RH
 Engineer : Shinichi Miyazono

Mode / Remarks : WALN Tx 11g 9Mbps 2437MHz

LIMIT : FCC15.207 QP
 FCC15.207 AV

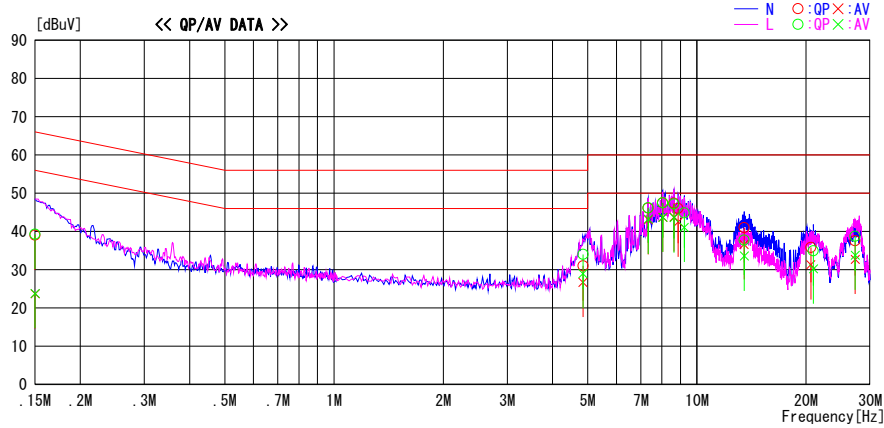

Frequency [MHz]	Reading Level		Corr. Factor [dB]	Results		Limit		Margin		Phase	Comment
	QP [dBuV]	AV [dBuV]		QP [dBuV]	AV [dBuV]	QP [dBuV]	AV [dBuV]	QP [dB]	AV [dB]		
0.15000	25.8	10.5	13.2	39.0	23.7	66.0	56.0	27.0	32.3	N	
4.85520	17.4	13.1	13.6	31.0	26.7	56.0	46.0	25.0	19.3	N	
7.33920	32.3	29.3	13.8	46.1	43.1	60.0	50.0	13.9	6.9	N	
8.05160	33.6	29.8	13.9	47.5	43.7	60.0	50.0	12.5	6.3	N	
8.64150	33.4	29.8	14.0	47.4	43.8	60.0	50.0	12.6	6.2	N	
8.87790	32.0	28.5	14.0	46.0	42.5	60.0	50.0	14.0	7.5	N	
13.48800	26.8	22.4	14.2	41.0	36.6	60.0	50.0	19.0	13.4	N	
20.60000	21.2	16.7	14.6	35.8	31.3	60.0	50.0	24.2	18.7	N	
27.29100	22.8	17.9	14.8	37.6	32.7	60.0	50.0	22.4	17.3	N	
0.15000	26.1	10.6	13.2	39.3	23.8	66.0	56.0	26.7	32.2	L	
4.85470	20.4	15.4	13.6	34.0	29.0	56.0	46.0	22.0	17.0	L	
7.33920	32.4	29.4	13.8	46.2	43.2	60.0	50.0	13.8	6.8	L	
8.05140	33.6	29.8	13.9	47.5	43.7	60.0	50.0	12.5	6.3	L	
8.63980	33.2	29.6	14.0	47.2	43.6	60.0	50.0	12.8	6.4	L	
9.22300	30.8	27.1	14.0	44.8	41.1	60.0	50.0	15.2	8.9	L	
13.49200	23.5	19.4	14.2	37.7	33.6	60.0	50.0	22.3	16.4	L	
20.94000	20.3	15.6	14.6	34.9	30.2	60.0	50.0	25.1	19.8	L	
27.29400	23.9	19.0	14.8	38.7	33.8	60.0	50.0	21.3	16.2	L	

CHART : WITH FACTOR. Peak hold data. CALCULATION : RESULT[dBuV] = READING[dBuV] + C.F.[dB] (LISN + ATTN + CABLE)
 Except for the above table : adequate margin data below the limits.

6dB Bandwidth

Test place Ise EMC Lab. No.11 Measurement Room
Report No. 11119465H
Date January 11, 2016
Temperature / Humidity 22 deg. C / 31 % RH
Engineer Shinichi Miyazono
Mode Tx

Mode	Frequency [MHz]	6dB Bandwidth [MHz]	Limit [kHz]
11b	2412	7.296	> 500
	2437	7.698	> 500
	2462	7.282	> 500
11g	2412	15.127	> 500
	2437	15.126	> 500
	2462	15.124	> 500
11n-20	2412	17.152	> 500
	2437	17.097	> 500
	2462	17.428	> 500

6dB Bandwidth

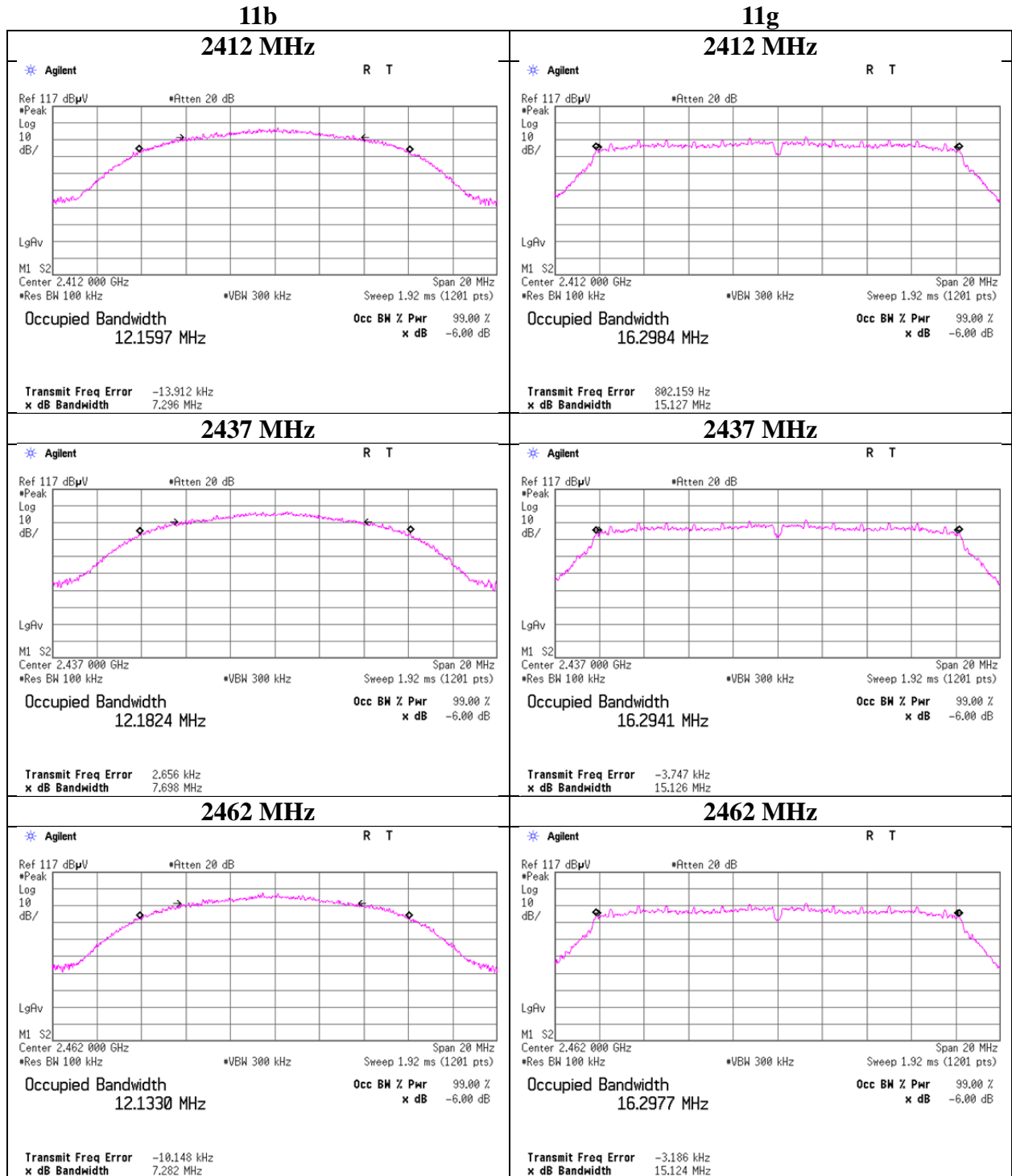

6dB Bandwidth

11n-20

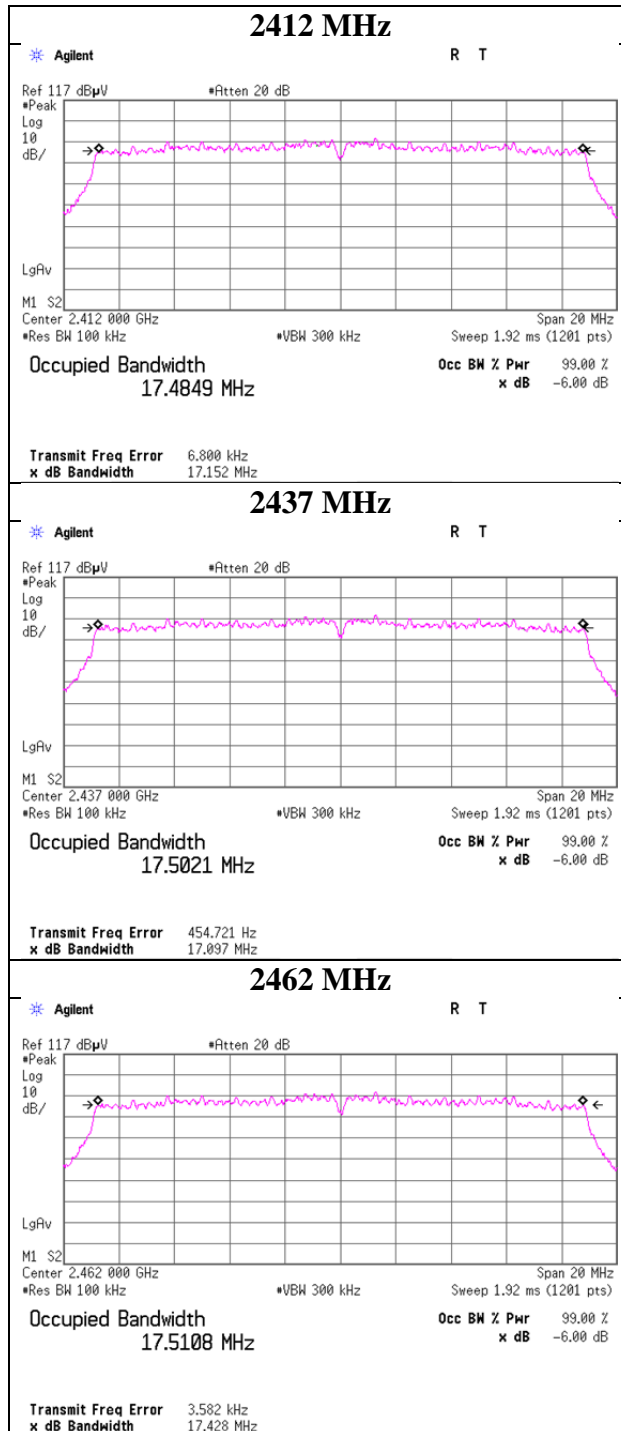

Maximum Peak Output Power

Test place	Ise EMC Lab. No.11 Measurement Room
Report No.	11119465H
Date	January 11, 2016
Temperature / Humidity	22 deg. C / 31 % RH
Engineer	Shinichi Miyazono
Mode	Tx 11b

Freq. [MHz]	Reading [dBm]	Cable Loss [dB]	Atten. Loss [dB]	Result		Limit		Margin [dB]
				[dBm]	[mW]	[dBm]	[mW]	
2412	8.30	0.50	10.03	18.83	76.38	30.00	1000	11.17
2437	8.37	0.50	10.03	18.90	77.62	30.00	1000	11.10
2462	8.34	0.50	10.03	18.87	77.09	30.00	1000	11.13

Sample Calculation:

Result = Reading + Cable Loss (including the cable(s) customer supplied) + Attenuator Loss

2437MHz

Rate [Mbps]	Reading [dBm]	Remark
1	8.02	
2	8.21	
5.5	8.23	
11	8.37	*

*: Worst Rate

All comparison were carried out on same frequency and measurement factors.

Maximum Peak Output Power

Test place	Ise EMC Lab. No.11 Measurement Room
Report No.	11119465H
Date	January 11, 2016
Temperature / Humidity	22 deg. C / 31 % RH
Engineer	Shinichi Miyazono
Mode	Tx 11g

Freq. [MHz]	Reading [dBm]	Cable Loss [dB]	Atten. Loss [dB]	Result		Limit		Margin [dB]
				[dBm]	[mW]	[dBm]	[mW]	
2412	13.48	0.50	10.03	24.01	251.77	30.00	1000	5.99
2437	13.52	0.50	10.03	24.05	254.10	30.00	1000	5.95
2462	13.40	0.50	10.03	23.93	247.17	30.00	1000	6.07

Sample Calculation:

Result = Reading + Cable Loss (including the cable(s) customer supplied) + Attenuator Loss

2437 MHz

Rate [Mbps]	Reading [dBm]	Remark
6	13.37	
9	13.52	*
12	13.26	
18	13.36	
24	13.45	
36	12.96	
48	13.22	
54	12.89	

*: Worst Rate

All comparison were carried out on same frequency and measurement factors.

Maximum Peak Output Power

Test place	Ise EMC Lab. No.11 Measurement Room
Report No.	11119465H
Date	January 11, 2016
Temperature / Humidity	22 deg. C / 31 % RH
Engineer	Shinichi Miyazono
Mode	Tx 11n-20

Freq. [MHz]	Reading [dBm]	Cable Loss [dB]	Atten. Loss [dB]	Result		Limit		Margin [dB]
				[dBm]	[mW]	[dBm]	[mW]	
2412	13.17	0.50	10.03	23.70	234.42	30.00	1000	6.30
2437	13.43	0.50	10.03	23.96	248.89	30.00	1000	6.04
2462	13.36	0.50	10.03	23.89	244.91	30.00	1000	6.11

Sample Calculation:

Result = Reading + Cable Loss (including the cable(s) customer supplied) + Attenuator Loss

2437 MHz

MCS Number	Reading [dBm]	Remark
0	13.16	
1	13.29	
2	13.20	
3	13.21	
4	13.33	
5	13.43	*
6	13.24	
7	13.21	

* Worst MCS

All comparison were carried out on same frequency and measurement factors.

Average Output Power

Test place : Ise EMC Lab. No.11 Measurement Room
 Report No. : 11119465H
 Date : January 11, 2016
 Temperature / Humidity : 22 deg. C / 31 % RH
 Engineer : Shinichi Miyazono
 Mode : Tx

11b 11 Mbps

Freq. [MHz]	Reading [dBm]	Cable Loss [dB]	Atten. Loss [dB]	Result (Frame power)		Duty factor [dB]	Result (Burst power)	
				[dBm]	[mW]		[dBm]	[mW]
2412	4.96	0.50	10.03	15.49	35.40	0.05	15.54	35.81
2437	5.06	0.50	10.03	15.59	36.22	0.05	15.64	36.64
2462	5.02	0.50	10.03	15.55	35.89	0.05	15.60	36.31

11g 9 Mbps

Freq. [MHz]	Reading [dBm]	Cable Loss [dB]	Atten. Loss [dB]	Result (Frame power)		Duty factor [dB]	Result (Burst power)	
				[dBm]	[mW]		[dBm]	[mW]
2412	2.56	0.50	10.03	13.09	20.37	0.07	13.16	20.70
2437	2.60	0.50	10.03	13.13	20.56	0.07	13.20	20.89
2462	2.53	0.50	10.03	13.06	20.23	0.07	13.13	20.56

11n-20 MCS 5

Freq. [MHz]	Reading [dBm]	Cable Loss [dB]	Atten. Loss [dB]	Result (Frame power)		Duty factor [dB]	Result (Burst power)	
				[dBm]	[mW]		[dBm]	[mW]
2412	2.12	0.50	10.03	12.65	18.41	0.33	12.98	19.86
2437	2.16	0.50	10.03	12.69	18.58	0.33	13.02	20.04
2462	2.15	0.50	10.03	12.68	18.54	0.33	13.01	20.00

Sample Calculation:

Result (Frame power) = Reading + Cable Loss (including the cable(s) customer supplied) + Attenuator

Result (Burst power) = Frame power + Duty factor

Burst rate confirmation

Test place	Ise EMC Lab. No.11 Measurement Room
Report No.	11119465H
Date	January 11, 2016
Temperature / Humidity	22 deg. C / 31 % RH
Engineer	Shinichi Miyazono
Mode	Tx

11b 11 Mbps

11g 9 Mbps

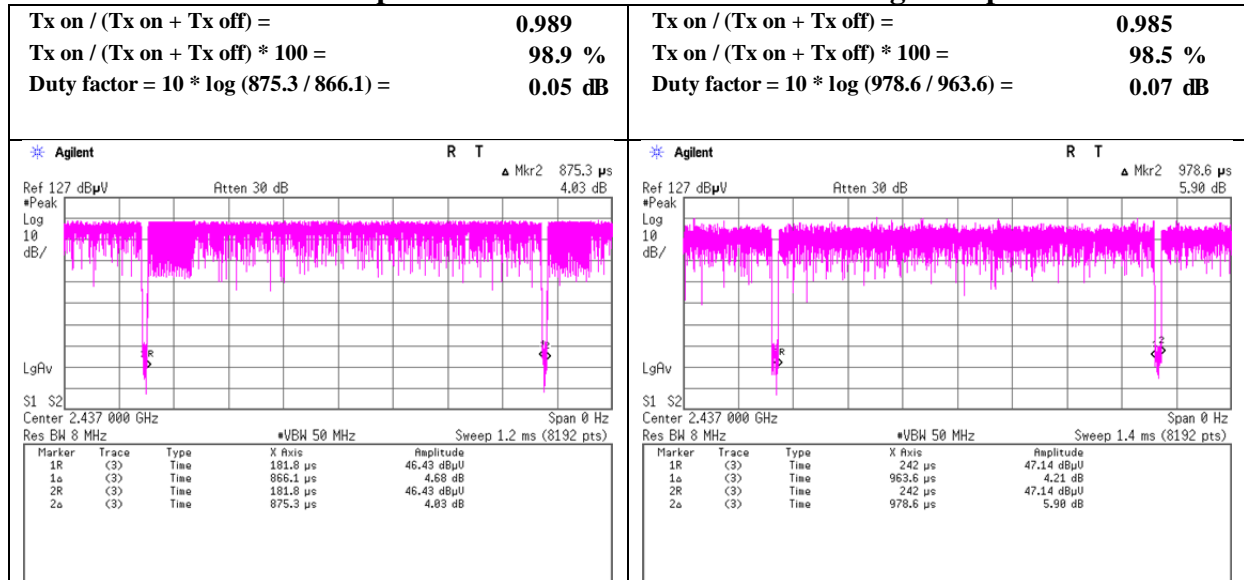

11n-20 MCS 5

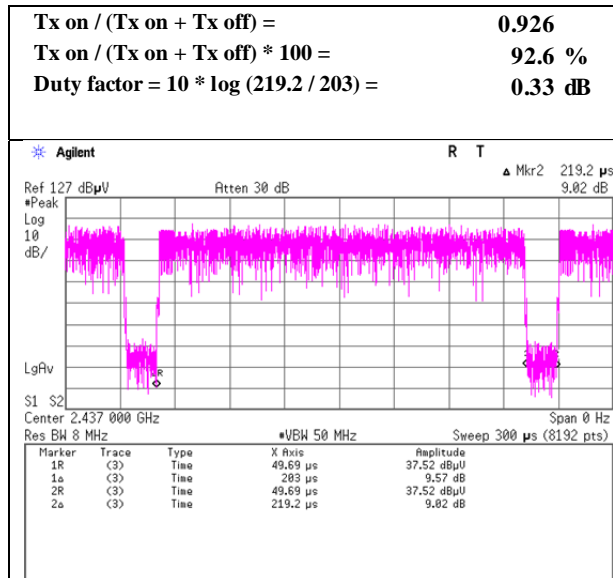

Radiated Spurious Emission

Test place : Ise EMC Lab. No.3 Semi Anechoic Chamber
Report No. : 11119465H
Date : January 9, 2016 January 10, 2016
Temperature / Humidity : 23 deg. C / 39 % RH 22 deg. C / 32 % RH
Engineer : Kazuya Yoshioka Shinichi Miyazono
 (1GHz - 10GHz) (10GHz - 26.5GHz)
Mode : Tx 11b 2412 MHz

Polarity	Frequency [MHz]	Detector	Reading [dBuV]	Ant.Fac. [dB/m]	Loss [dB]	Gain [dB]	Result [dBuV/m]	Limit [dBuV/m]	Margin [dB]	Remark
Hori	2390.000	PK	50.5	26.9	6.6	32.0	52.0	73.9	21.9	
Hori	4824.000	PK	41.1	31.8	8.8	31.3	50.4	73.9	23.5	
Hori	7236.000	PK	41.6	36.0	10.0	32.0	55.6	73.9	18.3	
Hori	9648.000	PK	42.7	38.2	10.8	32.4	59.3	73.9	14.6	
Hori	2390.000	AV	41.8	26.9	6.6	32.0	43.3	53.9	10.6	
Hori	4824.000	AV	30.7	31.8	8.8	31.3	40.0	53.9	13.9	
Hori	7236.000	AV	31.7	36.0	10.0	32.0	45.7	53.9	8.2	
Hori	9648.000	AV	30.8	38.2	11.0	32.4	47.6	53.9	6.3	
Vert	2390.000	PK	52.1	26.9	6.6	32.0	53.6	73.9	20.3	
Vert	4824.000	PK	41.4	31.8	8.8	31.3	50.7	73.9	23.2	
Vert	7236.000	PK	41.7	36.0	10.0	32.0	55.7	73.9	18.2	
Vert	9648.000	PK	42.7	38.2	10.8	32.4	59.3	73.9	14.6	
Vert	2390.000	AV	38.5	26.9	6.6	32.0	40.0	53.9	13.9	
Vert	4824.000	AV	30.3	31.8	8.8	31.3	39.6	53.9	14.3	
Vert	7236.000	AV	31.7	36.0	10.0	32.0	45.7	53.9	8.2	
Vert	9648.000	AV	30.8	38.2	11.0	32.4	47.6	53.9	6.3	

Result = Reading + Ant Factor + Loss (Cable+Attenuator+Filter+Distance factor) - Gain(Amplifier)

*Other frequency noises omitted in this report were not seen or had enough margin (more than 20 dB).

Distance factor: 1 GHz - 10 GHz 20log (4.5 m / 3.0 m) = 3.5 dB
 10 GHz - 26.5 GHz 20log (1.0 m / 3.0 m) = -9.5 dB

20dBc Data Sheet

Polarity	Frequency	Detector	Reading	Ant.Fac.	Loss	Gain	Result	Limit	Margin	Remark
Hori	2412.000	PK	101.5	26.9	6.6	32.0	103.0	-	-	Carrier
Hori	2400.000	PK	56.4	26.9	6.6	32.0	57.9	83.0	25.1	
Vert	2412.000	PK	102.0	26.9	6.6	32.0	103.5	-	-	Carrier
Vert	2400.000	PK	55.9	26.9	6.6	32.0	57.4	83.5	26.1	

Result = Reading + Ant Factor + Loss (Cable+Attenuator+Filter+Distance factor) - Gain(Amplifier)

Radiated Spurious Emission (Reference Plot for band-edge)

Test place	Ise EMC Lab. No.3 Semi Anechoic Chamber
Report No.	11119465H
Date	January 9, 2016
Temperature / Humidity	23 deg. C / 39 % RH
Engineer	Kazuya Yoshioka
Mode	Tx 11b 2412 MHz

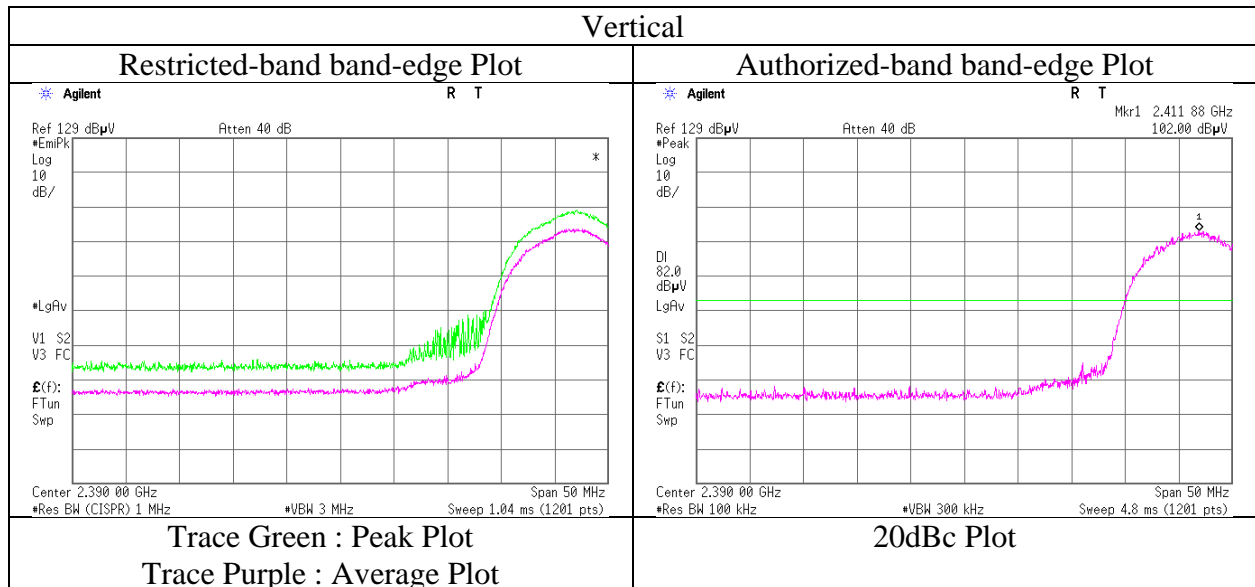
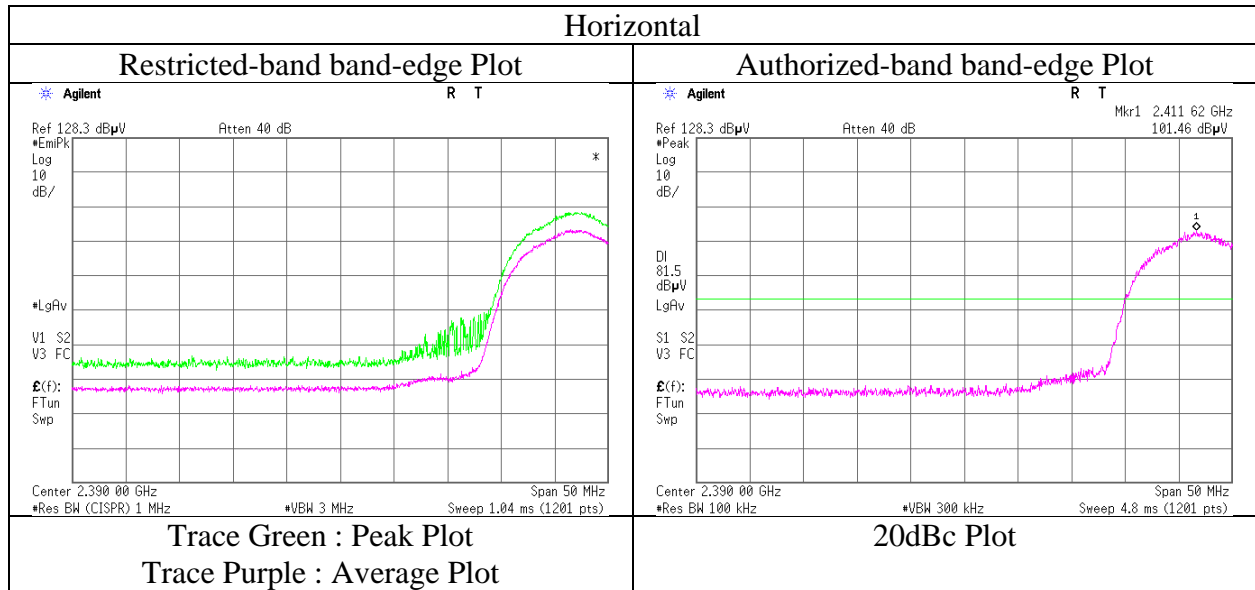

* Final result of restricted band edge was shown in tabular data.

Radiated Spurious Emission

Test place : Ise EMC Lab. No.3 Semi Anechoic Chamber
Report No. : 11119465H
Date : January 9, 2016 January 10, 2016
Temperature / Humidity : 23 deg. C / 39 % RH 22 deg. C / 32 % RH
Engineer : Kazuya Yoshioka Shinichi Miyazono
 (1GHz - 10GHz) (10GHz - 26.5GHz)
Mode : Tx 11b 2437 MHz

Polarity	Frequency [MHz]	Detector	Reading [dBuV]	Ant.Fac. [dB/m]	Loss [dB]	Gain [dB]	Result [dBuV/m]	Limit [dBuV/m]	Margin [dB]	Remark
Hori	4874.000	PK	39.9	31.9	9.0	31.3	49.5	73.9	24.4	
Hori	7311.000	PK	41.6	36.0	10.3	32.0	55.9	73.9	18.0	
Hori	9748.000	PK	41.7	38.2	11.0	32.4	58.5	73.9	15.4	
Hori	4874.000	AV	33.0	31.9	9.0	31.3	42.6	53.9	11.3	
Hori	7311.000	AV	33.9	36.0	10.3	32.0	48.2	53.9	5.7	
Hori	9748.000	AV	30.9	38.2	11.0	32.4	47.7	53.9	6.2	
Vert	4874.000	PK	40.0	31.9	9.0	31.3	49.6	73.9	24.3	
Vert	7311.000	PK	41.9	36.0	10.3	32.0	56.2	73.9	17.7	
Vert	9748.000	PK	42.7	38.2	11.0	32.4	59.5	73.9	14.4	
Vert	4874.000	AV	33.0	31.9	9.0	31.3	42.6	53.9	11.3	
Vert	7311.000	AV	33.9	36.0	10.3	32.0	48.2	53.9	5.7	
Vert	9748.000	AV	34.8	38.2	11.0	32.4	51.6	53.9	2.3	

Result = Reading + Ant Factor + Loss (Cable+Attenuator+Filter+Distance factor) - Gain(Amplifier)

*Other frequency noises omitted in this report were not seen or had enough margin (more than 20 dB).

Distance factor: 1 GHz - 10 GHz 20log (4.5 m / 3.0 m) = 3.5 dB
 10 GHz - 26.5 GHz 20log (1.0 m / 3.0 m) = -9.5 dB

Radiated Spurious Emission

Test place : Ise EMC Lab. No.3 Semi Anechoic Chamber
Report No. : 11119465H
Date : January 9, 2016 January 10, 2016
Temperature / Humidity : 23 deg. C / 39 % RH 22 deg. C / 32 % RH
Engineer : Kazuya Yoshioka Shinichi Miyazono
 (1GHz - 10GHz) (10GHz - 26.5GHz)
Mode : Tx 11b 2462 MHz

Polarity	Frequency [MHz]	Detector	Reading [dBuV]	Ant.Fac. [dB/m]	Loss [dB]	Gain [dB]	Result [dBuV/m]	Limit [dBuV/m]	Margin [dB]	Remark
Hori	2483.500	PK	51.7	26.9	6.8	32.0	53.4	73.9	20.5	
Hori	4924.000	PK	41.4	32.0	8.9	31.3	51.0	73.9	22.9	
Hori	7386.000	PK	41.8	36.0	10.2	32.1	55.9	73.9	18.0	
Hori	9848.000	PK	42.4	38.2	11.1	32.5	59.2	73.9	14.7	
Hori	2483.500	AV	42.9	26.9	6.8	32.0	44.6	53.9	9.3	
Hori	4924.000	AV	32.7	32.0	8.9	31.3	42.3	53.9	11.6	
Hori	7386.000	AV	31.9	36.0	10.2	32.1	46.0	53.9	7.9	
Hori	9848.000	AV	35.4	38.2	11.1	32.5	52.2	53.9	1.7	
Vert	2483.500	PK	52.7	26.9	6.8	32.0	54.4	73.9	19.5	
Vert	4924.000	PK	41.4	32.0	8.9	31.3	51.0	73.9	22.9	
Vert	7386.000	PK	41.7	36.0	10.2	32.1	55.8	73.9	18.1	
Vert	9848.000	PK	43.3	38.2	11.1	32.5	60.1	73.9	13.8	
Vert	2483.500	AV	43.8	26.9	6.8	32.0	45.5	53.9	8.4	
Vert	4924.000	AV	32.7	32.0	8.9	31.3	42.3	53.9	11.6	
Vert	7386.000	AV	31.9	36.0	10.2	32.1	46.0	53.9	7.9	
Vert	9848.000	AV	33.7	38.2	11.1	32.5	50.5	53.9	3.4	

Result = Reading + Ant Factor + Loss (Cable+Attenuator+Filter+Distance factor) - Gain(Amplifier)

*Other frequency noises omitted in this report were not seen or had enough margin (more than 20 dB).

Distance factor: 1 GHz - 10 GHz 20log (4.5 m / 3.0 m) = 3.5 dB
 10 GHz - 26.5 GHz 20log (1.0 m / 3.0 m) = -9.5 dB

Radiated Spurious Emission
(Reference Plot for band-edge)

Test place	Ise EMC Lab. No.3 Semi Anechoic Chamber
Report No.	11119465H
Date	January 9, 2016
Temperature / Humidity	23 deg. C / 39 % RH
Engineer	Kazuya Yoshioka
Mode	Tx 11b 2462 MHz

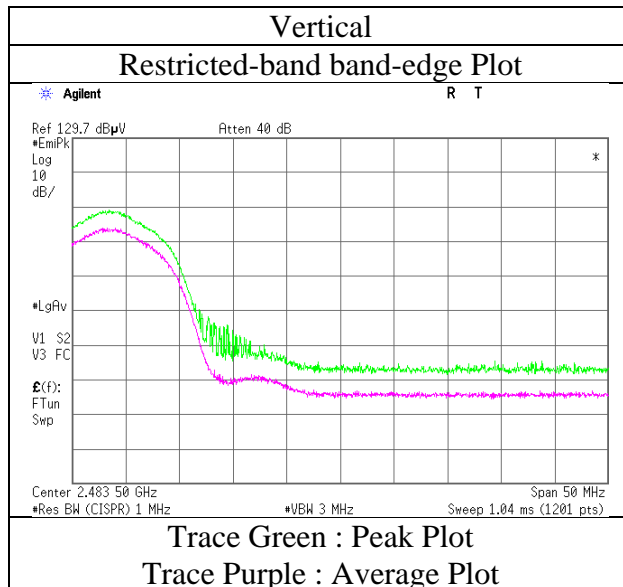
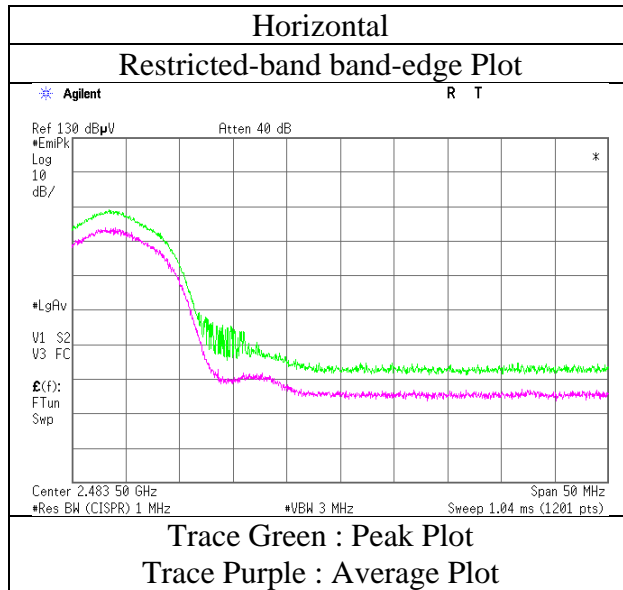

* Final result of restricted band edge was shown in tabular data.

Radiated Spurious Emission

Test place : Ise EMC Lab. No.3 Semi Anechoic Chamber
Report No. : 11119465H
Date : January 9, 2016 January 10, 2016
Temperature / Humidity : 23 deg. C / 39 % RH 22 deg. C / 32 % RH
Engineer : Kazuya Yoshioka Shinichi Miyazono
(1GHz - 10GHz) (10GHz - 26.5GHz)
Mode : Tx 11g 2412 MHz

Polarity	Frequency [MHz]	Detector	Reading [dBuV]	Ant.Fac. [dB/m]	Loss [dB]	Gain [dB]	Result [dBuV/m]	Limit [dBuV/m]	Margin [dB]	Remark
Hori	2390.000	PK	69.8	26.9	6.8	32.0	71.5	73.9	2.4	
Hori	4824.000	PK	40.7	31.8	9.0	31.3	50.2	73.9	23.7	
Hori	7236.000	PK	42.3	36.0	10.2	32.0	56.5	73.9	17.4	
Hori	9648.000	PK	42.4	38.2	11.0	32.4	59.2	73.9	14.7	
Hori	2390.000	AV	44.7	26.9	6.8	32.0	46.4	53.9	7.5	
Hori	4824.000	AV	30.5	31.8	9.0	31.3	40.0	53.9	13.9	
Hori	7236.000	AV	31.9	36.0	10.2	32.0	46.1	53.9	7.8	
Hori	9648.000	AV	31.0	38.2	11.0	32.4	47.8	53.9	6.1	
Vert	2390.000	PK	71.8	26.9	6.8	32.0	73.5	73.9	0.4	
Vert	4824.000	PK	40.8	31.8	9.0	31.3	50.3	73.9	23.6	
Vert	7236.000	PK	42.1	36.0	10.2	32.0	56.3	73.9	17.6	
Vert	9648.000	PK	42.2	38.2	11.0	32.4	59.0	73.9	14.9	
Vert	2390.000	AV	46.8	26.9	6.8	32.0	48.5	53.9	5.4	
Vert	4824.000	AV	30.5	31.8	9.0	31.3	40.0	53.9	13.9	
Vert	7236.000	AV	31.9	36.0	10.2	32.0	46.1	53.9	7.8	
Vert	9648.000	AV	31.0	38.2	11.0	32.4	47.8	53.9	6.1	

Result = Reading + Ant Factor + Loss (Cable+Attenuator+Filter+Distance factor) - Gain(Amplifier)
*Other frequency noises omitted in this report were not seen or had enough margin (more than 20 dB).

Distance factor: 1 GHz - 10 GHz 20log (4.5 m / 3.0 m) = 3.5 dB
 10 GHz - 26.5 GHz 20log (1.0 m / 3.0 m) = -9.5 dB

20dBc Data Sheet

Polarity	Frequency	Detector	Reading	Ant.Fac.	Loss	Gain	Result	Limit	Margin	Remark
Hori	2412.000	PK	95.8	26.9	6.8	32.0	97.5	-	-	- Carrier
Hori	2400.000	PK	63.6	26.9	6.8	32.0	65.3	77.5	12.2	
Vert	2412.000	PK	96.6	26.9	6.8	32.0	98.3	-	-	- Carrier
Vert	2400.000	PK	61.4	26.9	6.8	32.0	63.1	78.3	15.2	

Result = Reading + Ant Factor + Loss (Cable+Attenuator+Filter+Distance factor) - Gain(Amplifier)

Radiated Spurious Emission (Reference Plot for band-edge)

Test place	Ise EMC Lab. No.3 Semi Anechoic Chamber
Report No.	11119465H
Date	January 9, 2016
Temperature / Humidity	23 deg. C / 39 % RH
Engineer	Kazuya Yoshioka
Mode	Tx 11g 2412 MHz

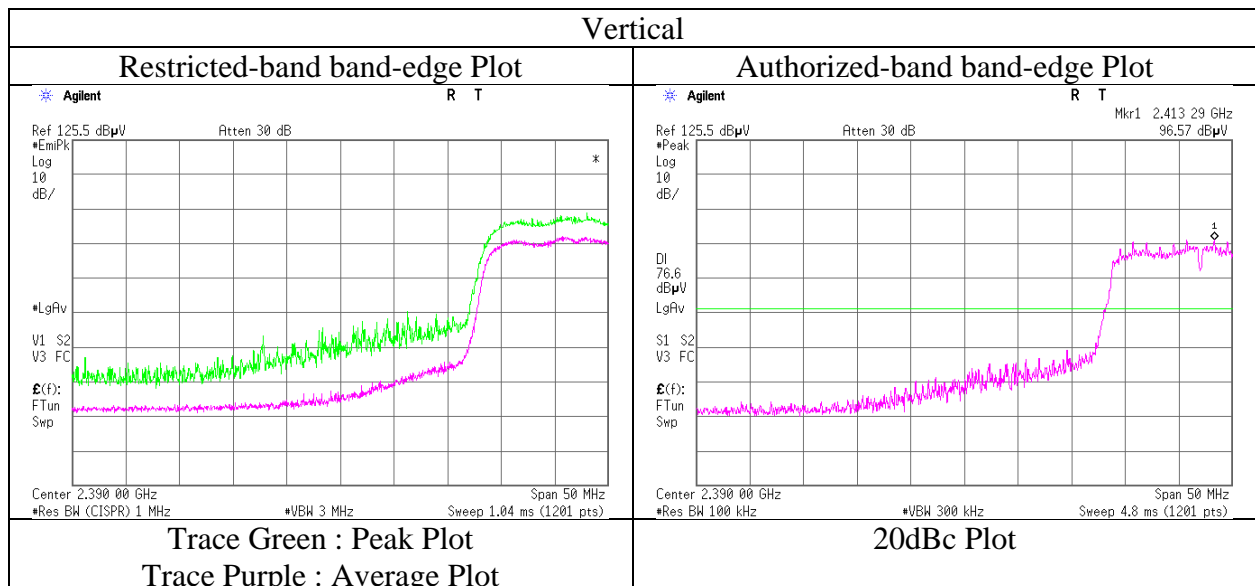
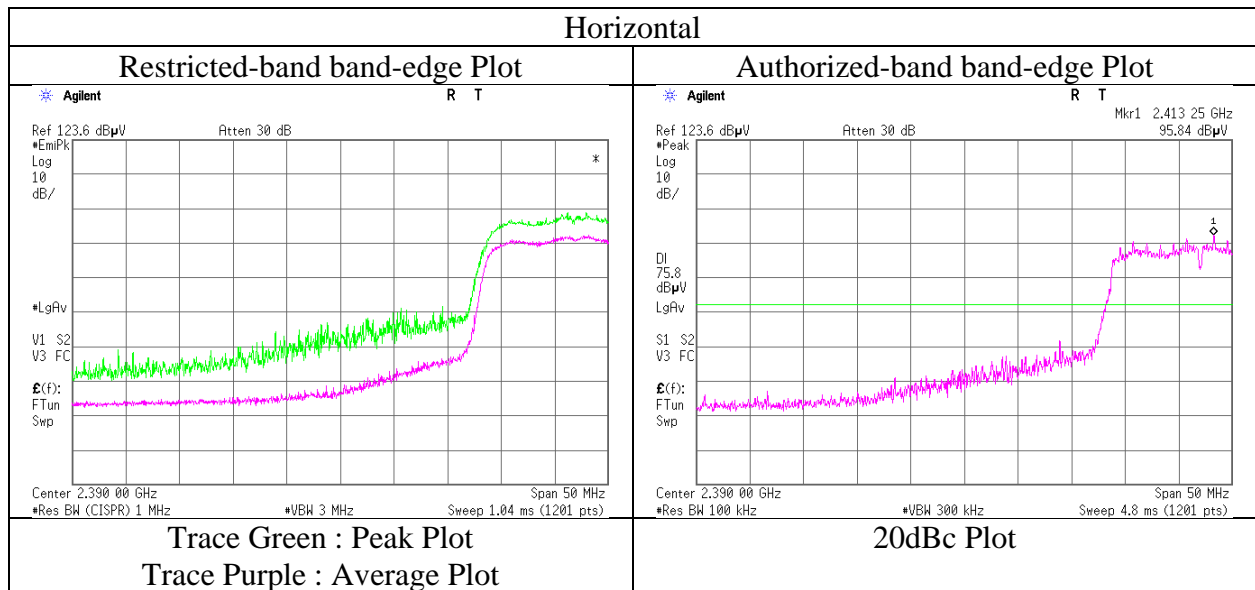

* Final result of restricted band edge was shown in tabular data.

Radiated Spurious Emission

Test place : Ise EMC Lab. No.3 Semi Anechoic Chamber
Report No. : 11119465H
Date : January 9, 2016 January 10, 2016
Temperature / Humidity : 23 deg. C / 39 % RH 22 deg. C / 32 % RH
Engineer : Kazuya Yoshioka Shinichi Miyazono
 (1GHz - 10GHz) (10GHz – 26.5GHz and Below 1GHz)
Mode : Tx 11g 2437 MHz

Polarity	Frequency [MHz]	Detector	Reading [dBuV]	Ant.Fac. [dB/m]	Loss [dB]	Gain [dB]	Result [dBuV/m]	Limit [dBuV/m]	Margin [dB]	Remark
Hori	101.541	QP	28.3	10.0	8.0	32.3	14.0	43.5	29.5	
Hori	160.749	QP	22.5	15.4	8.7	32.2	14.4	43.5	29.1	
Hori	260.399	QP	22.2	17.8	9.6	32.0	17.6	46.0	28.4	
Hori	406.832	QP	22.0	17.4	10.7	32.0	18.1	46.0	27.9	
Hori	613.833	QP	22.0	19.5	11.8	32.1	21.2	46.0	24.8	
Hori	772.503	QP	22.1	21.6	12.7	31.7	24.7	46.0	21.3	
Hori	4874.000	PK	40.3	31.9	9.0	31.3	49.9	73.9	24.0	
Hori	7311.000	PK	42.1	36.0	10.3	32.0	56.4	73.9	17.5	
Hori	9748.000	PK	43.2	38.2	11.0	32.4	60.0	73.9	13.9	
Hori	4874.000	AV	32.7	31.9	9.0	31.3	42.3	53.9	11.6	
Hori	7311.000	AV	33.9	36.0	10.3	32.0	48.2	53.9	5.7	
Hori	9748.000	AV	34.8	38.2	11.0	32.4	51.6	53.9	2.3	
Vert	101.541	QP	31.2	10.0	8.0	32.3	16.9	43.5	26.6	
Vert	160.949	QP	22.1	15.4	8.7	32.2	14.0	43.5	29.5	
Vert	261.749	QP	21.9	17.8	9.6	32.0	17.3	46.0	28.7	
Vert	406.166	QP	22.1	17.4	10.7	32.0	18.2	46.0	27.8	
Vert	611.500	QP	22.1	19.5	11.8	32.1	21.3	46.0	24.7	
Vert	776.003	QP	22.0	21.7	12.7	31.7	24.7	46.0	21.3	
Vert	4874.000	PK	40.1	31.9	9.0	31.3	49.7	73.9	24.2	
Vert	7311.000	PK	41.6	36.0	10.3	32.0	55.9	73.9	18.0	
Vert	9748.000	PK	42.7	38.2	11.0	32.4	59.5	73.9	14.4	
Vert	4874.000	AV	32.7	31.9	9.0	31.3	42.3	53.9	11.6	
Vert	7311.000	AV	33.9	36.0	10.3	32.0	48.2	53.9	5.7	
Vert	9748.000	AV	34.5	38.2	11.0	32.4	51.3	53.9	2.6	

Result = Reading + Ant Factor + Loss (Cable+Attenuator+Filter+Distance factor) - Gain(Amplifier)

*Other frequency noises omitted in this report were not seen or had enough margin (more than 20 dB).

Distance factor: 1 GHz - 10 GHz 20log (4.5 m / 3.0 m) = 3.5 dB
 10 GHz - 26.5 GHz 20log (1.0 m / 3.0 m) = -9.5 dB

Radiated Spurious Emission

Test place : Ise EMC Lab. No.3 Semi Anechoic Chamber
Report No. : 11119465H
Date : January 9, 2016 January 10, 2016
Temperature / Humidity : 23 deg. C / 39 % RH 22 deg. C / 32 % RH
Engineer : Kazuya Yoshioka Shinichi Miyazono
 (1GHz - 10GHz) (10GHz - 26.5GHz)
Mode : Tx 11g 2462 MHz

Polarity	Frequency [MHz]	Detector	Reading [dBuV]	Ant.Fac. [dB/m]	Loss [dB]	Gain [dB]	Result [dBuV/m]	Limit [dBuV/m]	Margin [dB]	Remark
Hori	2483.500	PK	71.1	26.9	6.8	32.0	72.8	73.9	1.1	
Hori	4924.000	PK	40.8	32.0	8.9	31.3	50.4	73.9	23.5	
Hori	7386.000	PK	41.8	36.0	10.2	32.1	55.9	73.9	18.0	
Hori	9848.000	PK	41.5	38.2	11.1	32.5	58.3	73.9	15.6	
Hori	2483.500	AV	50.8	26.9	6.8	32.0	52.5	53.9	1.4	*1)
Hori	4924.000	AV	30.3	32.0	8.9	31.3	39.9	53.9	14.0	
Hori	7386.000	AV	31.7	36.0	10.2	32.1	45.8	53.9	8.1	
Hori	9848.000	AV	32.9	38.2	11.1	32.5	49.7	53.9	4.2	
Vert	2483.500	PK	70.7	26.9	6.8	32.0	72.4	73.9	1.5	
Vert	4924.000	PK	40.4	32.0	8.9	31.3	50.0	73.9	23.9	
Vert	7386.000	PK	41.7	36.0	10.2	32.1	55.8	73.9	18.1	
Vert	9848.000	PK	43.0	38.2	11.1	32.5	59.8	73.9	14.1	
Vert	2483.500	AV	49.9	26.9	6.8	32.0	51.6	53.9	2.3	*1)
Vert	4924.000	AV	30.3	32.0	8.9	31.3	39.9	53.9	14.0	
Vert	7386.000	AV	31.7	36.0	10.2	32.1	45.8	53.9	8.1	
Vert	9848.000	AV	33.5	38.2	11.1	32.5	50.3	53.9	3.6	

Result = Reading + Ant Factor + Loss (Cable+Attenuator+Filter+Distance factor) - Gain(Amplifier)

*Other frequency noises omitted in this report were not seen or had enough margin (more than 20 dB).

Distance factor: 1 GHz - 10 GHz 20log (4.5 m / 3.0 m) = 3.5 dB
 10 GHz - 26.5 GHz 20log (1.0 m / 3.0 m) = -9.5 dB

*1) Integration Method

Radiated Spurious Emission (Reference Plot for band-edge)

Test place	Ise EMC Lab. No.3 Semi Anechoic Chamber
Report No.	11119465H
Date	January 9, 2016
Temperature / Humidity	23 deg. C / 39 % RH
Engineer	Kazuya Yoshioka
Mode	Tx 11g 2462 MHz

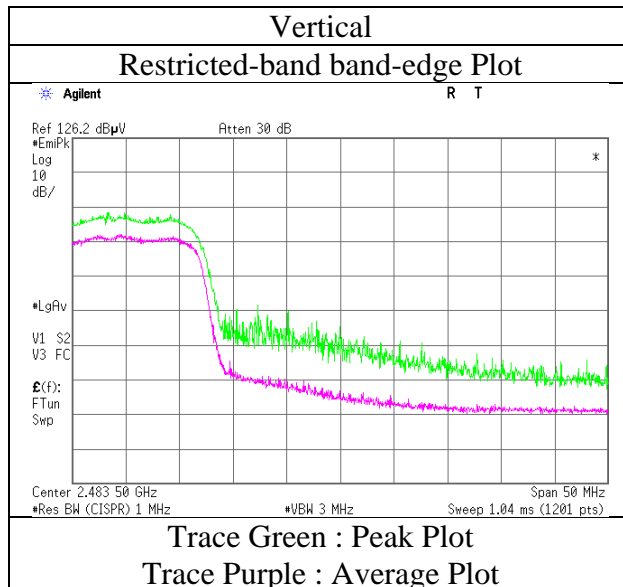
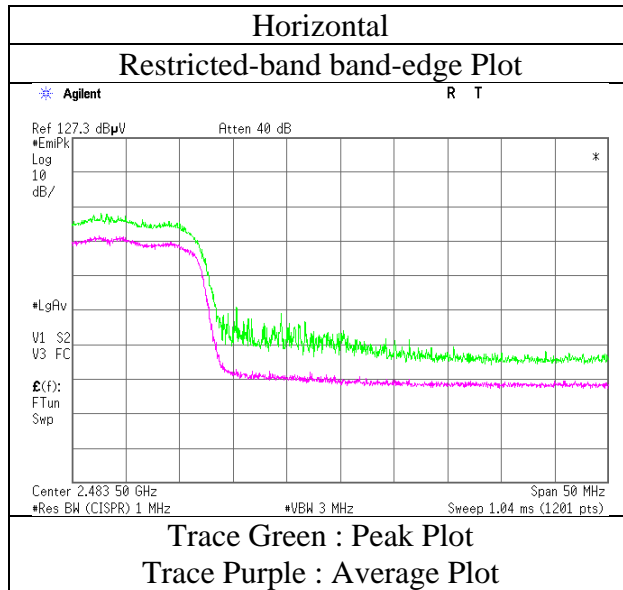

* Final result of restricted band edge was shown in tabular data.

UL Japan, Inc.

Ise EMC Lab.

4383-326 Asama-cho, Ise-shi, Mie-ken 516-0021 JAPAN

Telephone : +81 596 24 8999

Facsimile : +81 596 24 8124

Radiated Spurious Emission

Test place : Ise EMC Lab. No.3 Semi Anechoic Chamber
Report No. : 11119465H
Date : January 9, 2016 January 10, 2016
Temperature / Humidity : 23 deg. C / 39 % RH 22 deg. C / 32 % RH
Engineer : Kazuya Yoshioka Shinichi Miyazono
 (1GHz - 10GHz) (10GHz - 26.5GHz)
Mode : Tx 11n-20 2412 MHz

Polarity	Frequency [MHz]	Detector	Reading [dBuV]	Ant.Fac. [dB/m]	Loss [dB]	Gain [dB]	Duty Factor [dB]	Result [dBuV/m]	Limit [dBuV/m]	Margin [dB]	Remark
Hori	2390.000	PK	68.9	26.9	6.8	32.0	-	70.6	73.9	3.3	
Hori	2390.000	AV	51.6	26.9	6.8	32.0	0.3	53.6	53.9	0.3	*1)
Vert	2390.000	PK	67.0	26.9	6.8	32.0	-	68.7	73.9	5.2	
Vert	2390.000	AV	50.5	26.9	6.8	32.0	0.3	52.5	53.9	1.4	*1)

Result = Reading + Ant Factor + Loss (Cable+Attenuator+Filter+Distance factor) - Gain(Amplifier) + Duty factor
*Other frequency noises omitted in this report were not seen or had enough margin (more than 20 dB).

Distance factor: 1 GHz - 10 GHz 20log (4.5 m / 3.0 m) = 3.5 dB
 10 GHz - 26.5 GHz 20log (1.0 m / 3.0 m) = -9.5 dB

*1) Not Out of Band emission(Leakage Power)

20dBc Data Sheet

Polarity	Frequency	Detector	Reading	Ant.Fac.	Loss	Gain	Result	Limit	Margin	Remark
Hori	2412.000	PK	99.2	26.9	6.8	32.0	100.9	-	-	Carrier
Hori	2400.000	PK	60.6	26.9	6.8	32.0	62.3	80.9	18.6	
Vert	2412.000	PK	96.6	26.9	6.8	32.0	98.3	-	-	Carrier
Vert	2400.000	PK	61.9	26.9	6.8	32.0	63.6	78.3	14.7	

Result = Reading + Ant Factor + Loss (Cable+Attenuator+Filter+Distance factor) - Gain(Amplifier)

Radiated Spurious Emission (Reference Plot for band-edge)

Test place	Ise EMC Lab. No.3 Semi Anechoic Chamber
Report No.	11119465H
Date	January 9, 2016
Temperature / Humidity	23 deg. C / 39 % RH
Engineer	Kazuya Yoshioka
Mode	Tx 11n-20 2412 MHz

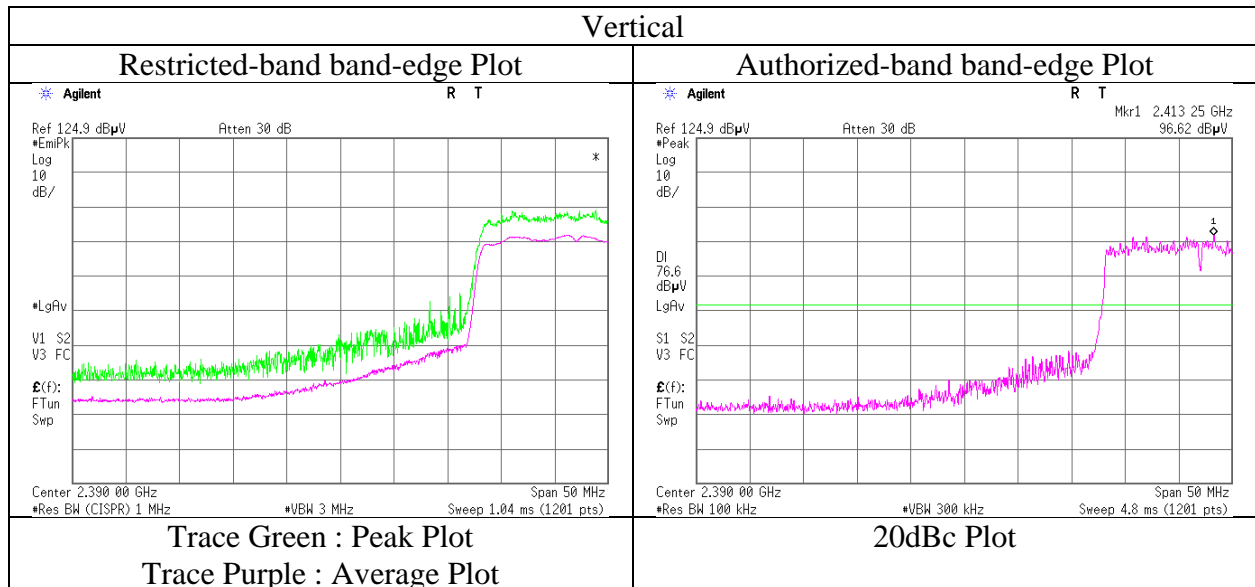
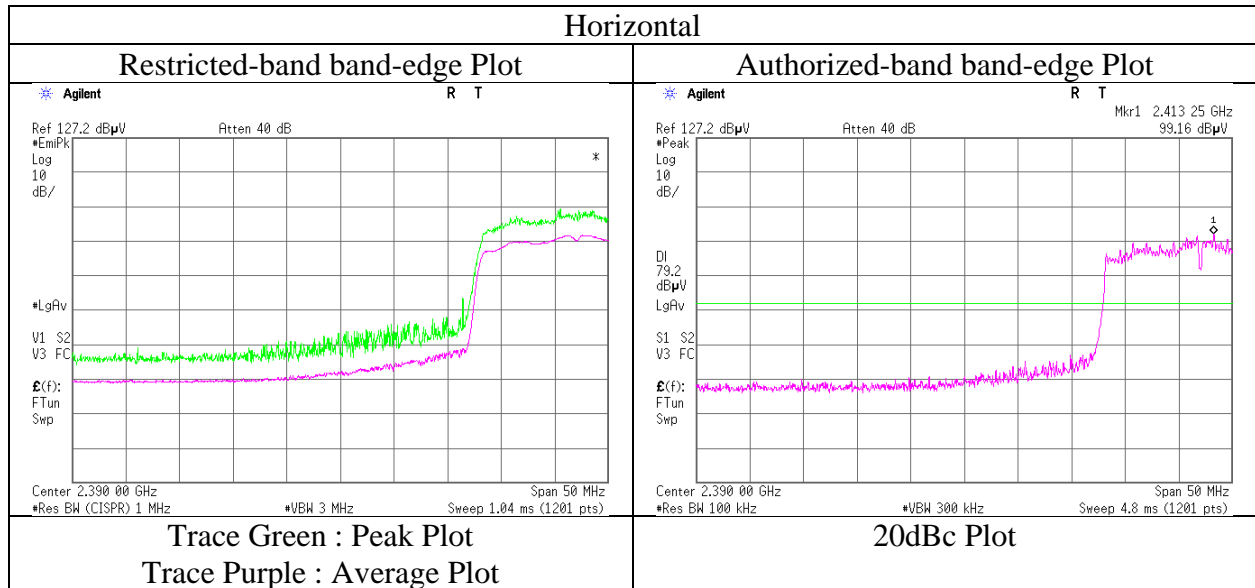

* Final result of restricted band edge was shown in tabular data.

Radiated Spurious Emission

Test place : Ise EMC Lab. No.3 Semi Anechoic Chamber
Report No. : 11119465H
Date : January 9, 2016 January 10, 2016
Temperature / Humidity : 23 deg. C / 39 % RH 22 deg. C / 32 % RH
Engineer : Kazuya Yoshioka Shinichi Miyazono
 (1GHz - 10GHz) (10GHz – 26.5GHz)
Mode : Tx 11n-20 2462 MHz

Polarity	Frequency [MHz]	Detector	Reading [dBuV]	Ant.Fac. [dB/m]	Loss [dB]	Gain [dB]	Duty Factor [dB]	Result [dBuV/m]	Limit [dBuV/m]	Margin [dB]	Remark
Hori	2483.500	PK	69.7	26.9	6.8	32.0	-	71.4	73.9	2.5	
Hori	2483.500	AV	50.0	26.9	6.8	32.0	0.3	52.0	53.9	1.9	*1),*2)
Vert	2483.500	PK	69.6	26.9	6.8	32.0	-	71.3	73.9	2.6	
Vert	2483.500	AV	49.7	26.9	6.8	32.0	0.3	51.7	53.9	2.2	*1),*2)

Result = Reading + Ant Factor + Loss (Cable+Attenuator+Filter+Distance factor) - Gain(Amplifier) + Duty factor

*Other frequency noises omitted in this report were not seen or had enough margin (more than 20 dB).

Distance factor: 1 GHz - 10 GHz 20log (4.5 m / 3.0 m) = 3.5 dB
 10 GHz - 26.5 GHz 20log (1.0 m / 3.0 m) = -9.5 dB

*1) Not Out of Band emission(Leakage Power)

*2) Integration method

Radiated Spurious Emission (Reference Plot for band-edge)

Test place	Ise EMC Lab. No.3 Semi Anechoic Chamber
Report No.	11119465H
Date	January 9, 2016
Temperature / Humidity	23 deg. C / 39 % RH
Engineer	Kazuya Yoshioka
Mode	Tx 11n-20 2462 MHz

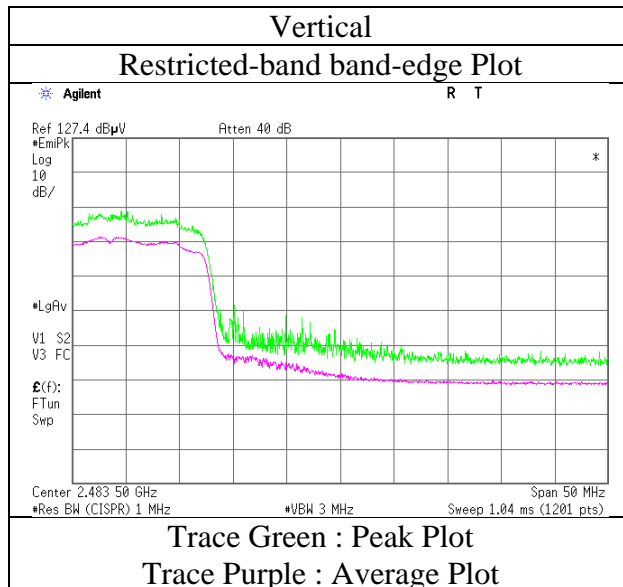
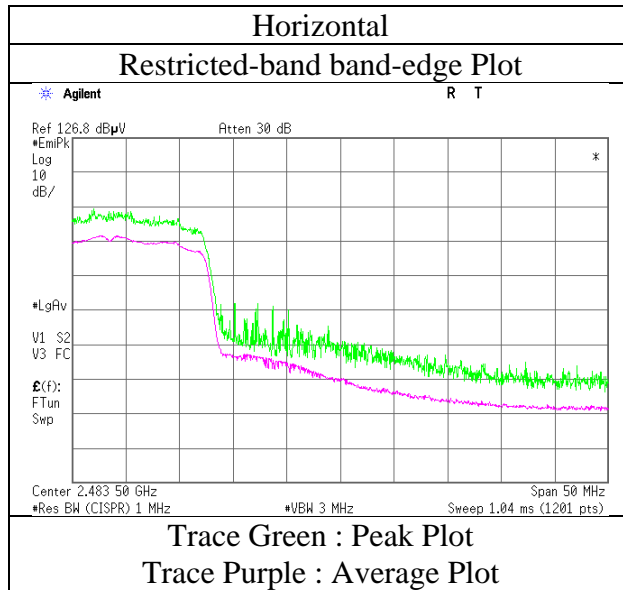

* Final result of restricted band edge was shown in tabular data.

Radiated Spurious Emission (Plot data, Worst case)

Test place	Ise EMC Lab. No.3 Semi Anechoic Chamber	
Report No.	11119465H	
Date	January 9, 2016	January 10, 2016
Temperature / Humidity	23 deg. C / 39 % RH	22 deg. C / 32 % RH
Engineer	Kazuya Yoshioka	Shinichi Miyazono
	(1GHz - 10GHz)	(10GHz – 26.5GHz and Below 1GHz)
Mode	Tx 11g 2437 MHz	

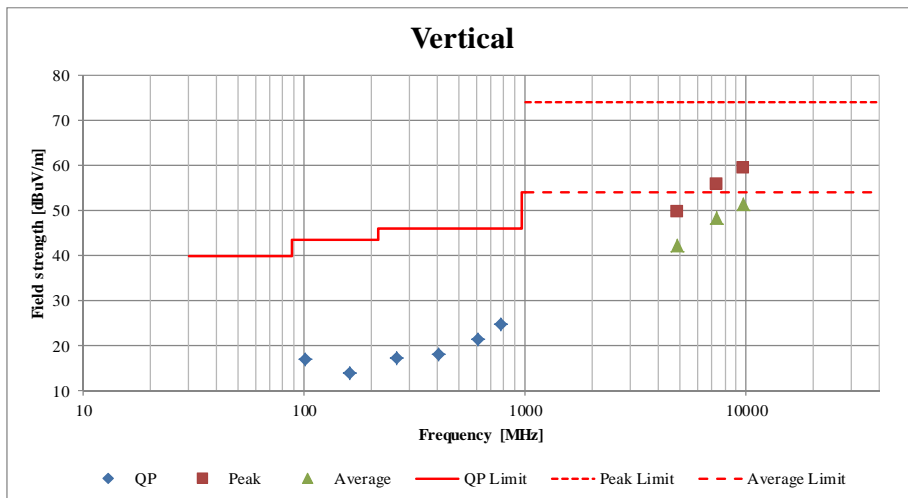
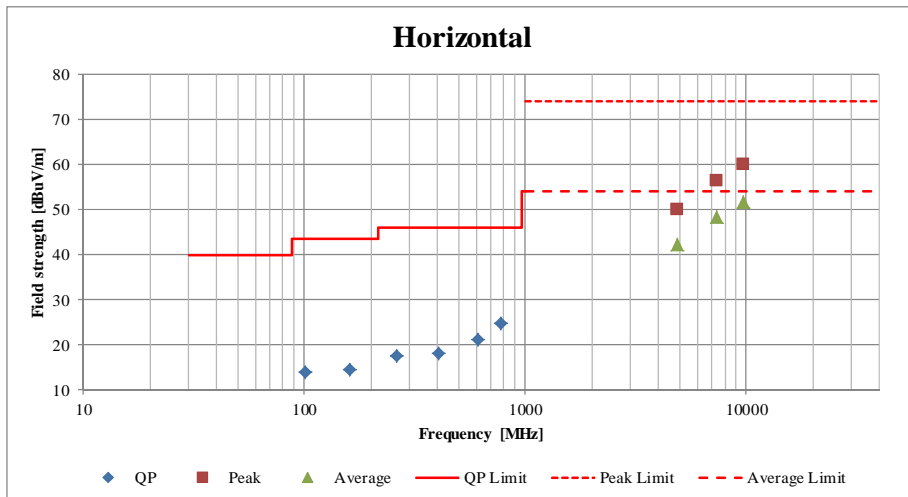

*These plots data contains sufficient number to show the trend of characteristic features for EUT.

Conducted Spurious Emission

Test place	Ise EMC Lab. No.11 Measurement Room
Report No.	11119465H
Date	January 11, 2016
Temperature / Humidity	22 deg. C / 31 % RH
Engineer	Shinichi Miyazono
Mode	Tx 11g 2437 MHz

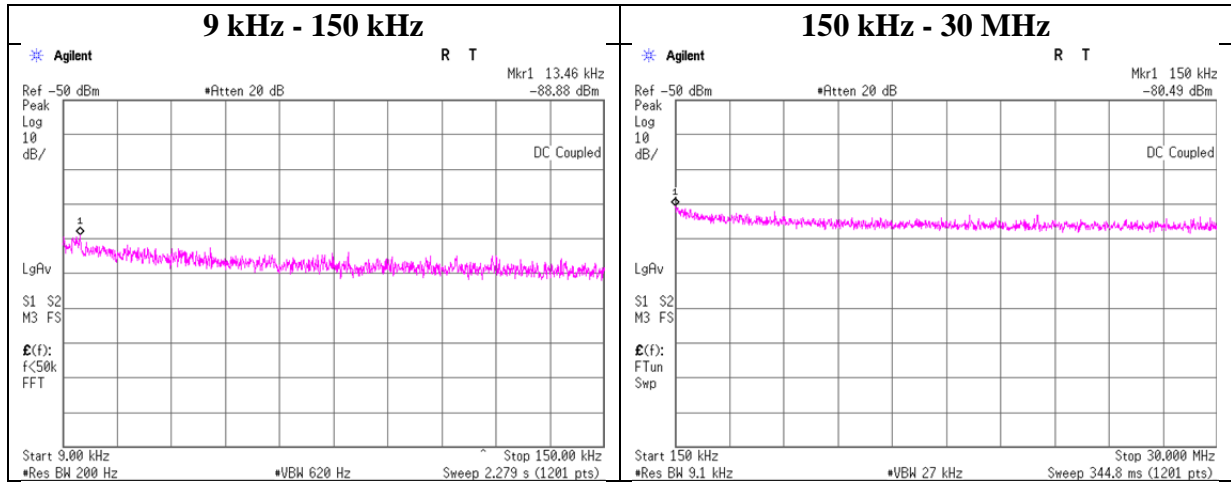

Frequency [kHz]	Reading [dBm]	Cable Loss [dB]	Attenuator Loss [dB]	Antenna Gain [dBi]	N (Number of Output)	EIRP [dBm]	Distance [m]	Ground bounce [dB]	E (field strength) [dBuV/m]	Limit [dBuV/m]	Margin [dB]	Remark
13.46	-88.9	0.01	9.8	2.0	1	-77.1	300	6.0	-15.8	45.0	60.8	
150.00	-80.5	0.01	9.8	2.0	1	-68.7	300	6.0	-7.4	24.0	31.4	

$E = \text{EIRP} - 20 \log(D) + \text{Ground bounce} + 104.8$ [dBuV/m]

$\text{EIRP} = \text{Reading} + \text{Cable Loss} + \text{Attenuator Loss} + \text{Antenna Gain} + 10 * \log(N)$

Power Density

Test place Ise EMC Lab. No.11 Measurement Room
Report No. 11119465H
Date January 11, 2016
Temperature / Humidity 22 deg. C / 31 % RH
Engineer Shinichi Miyazono
Mode Tx

11b

Freq. [MHz]	Reading [dBm]	Cable Loss [dB]	Atten. Loss [dB]	Result [dBm]	Limit [dBm]	Margin [dB]
2412.00	-18.05	1.44	10.03	-6.58	8.00	14.58
2437.00	-17.78	1.45	10.03	-6.30	8.00	14.30
2462.00	-17.90	1.45	10.03	-6.42	8.00	14.42

11g

Freq. [MHz]	Reading [dBm]	Cable Loss [dB]	Atten. Loss [dB]	Result [dBm]	Limit [dBm]	Margin [dB]
2412.00	-22.25	1.44	10.03	-10.78	8.00	18.78
2437.00	-21.52	1.45	10.03	-10.04	8.00	18.04
2462.00	-22.48	1.45	10.03	-11.00	8.00	19.00

11n-20

Freq. [MHz]	Reading [dBm]	Cable Loss [dB]	Atten. Loss [dB]	Result [dBm]	Limit [dBm]	Margin [dB]
2412.00	-22.51	1.44	10.03	-11.04	8.00	19.04
2437.00	-22.37	1.45	10.03	-10.89	8.00	18.89
2462.00	-22.45	1.45	10.03	-10.97	8.00	18.97

Sample Calculation:

Result = Reading + Cable Loss (including the cable(s) customer supplied) + Attenuator

Power Density

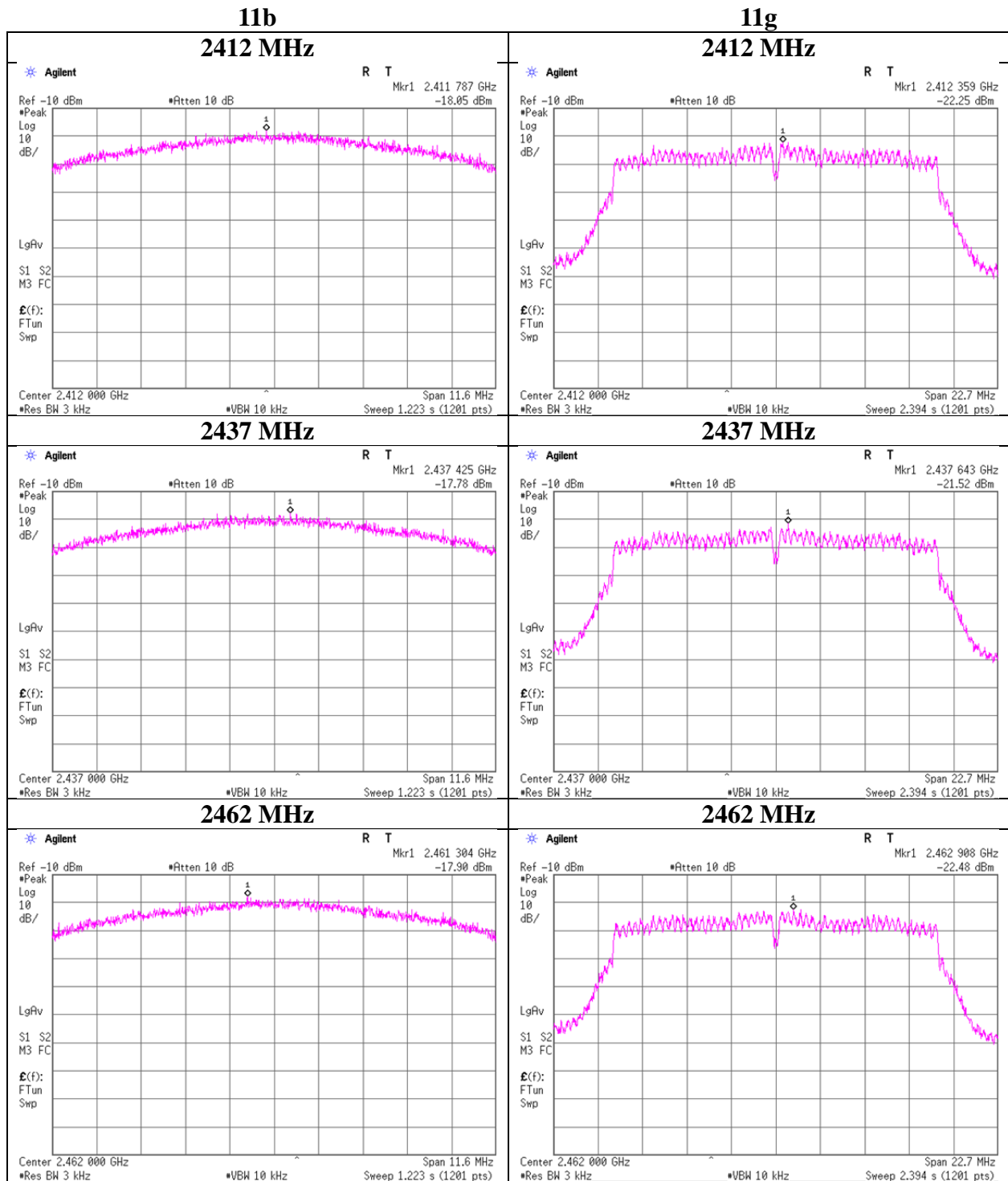

UL Japan, Inc.

Ise EMC Lab.

4383-326 Asama-cho, Ise-shi, Mie-ken 516-0021 JAPAN

Telephone : +81 596 24 8999

Facsimile : +81 596 24 8124

Power Density

11n-20

2412 MHz

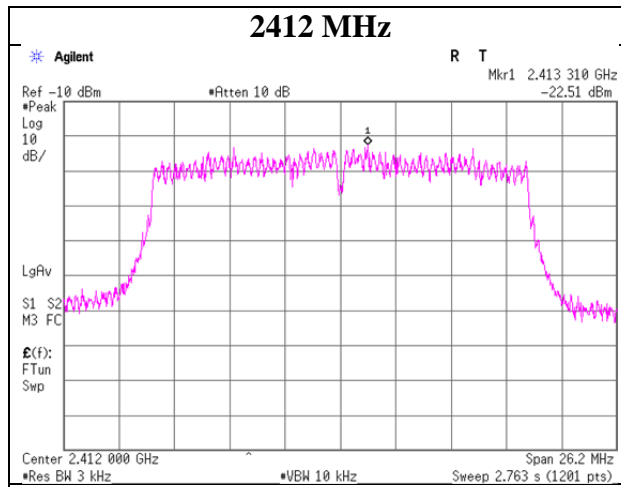

2437 MHz

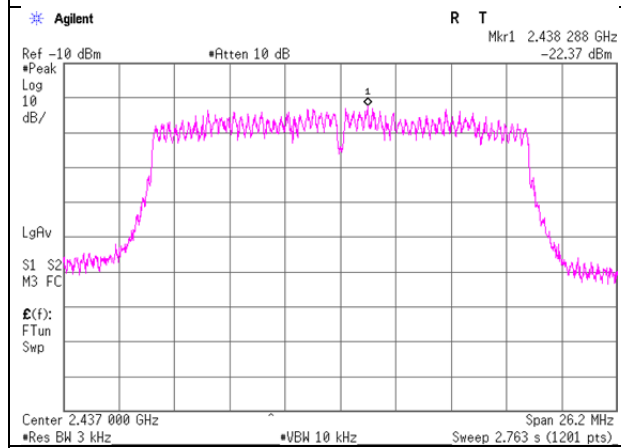

2462 MHz

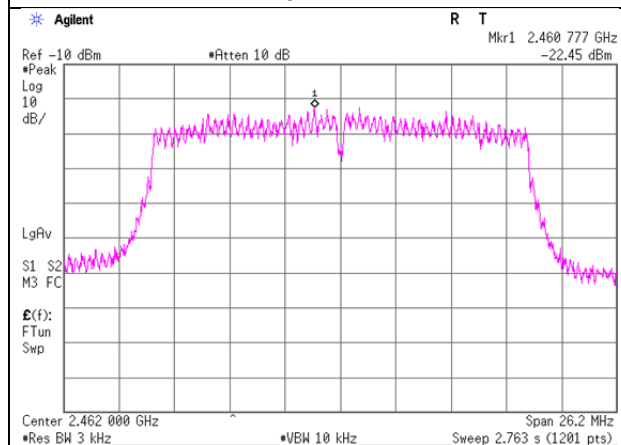

UL Japan, Inc.

Ise EMC Lab.

4383-326 Asama-cho, Ise-shi, Mie-ken 516-0021 JAPAN

Telephone : +81 596 24 8999

Facsimile : +81 596 24 8124

99% Occupied Bandwidth

Test place	Ise EMC Lab. No.11 Measurement Room
Report No.	11119465H
Date	January 11, 2016
Temperature / Humidity	22 deg. C / 31 % RH
Engineer	Shinichi Miyazono
Mode	Tx

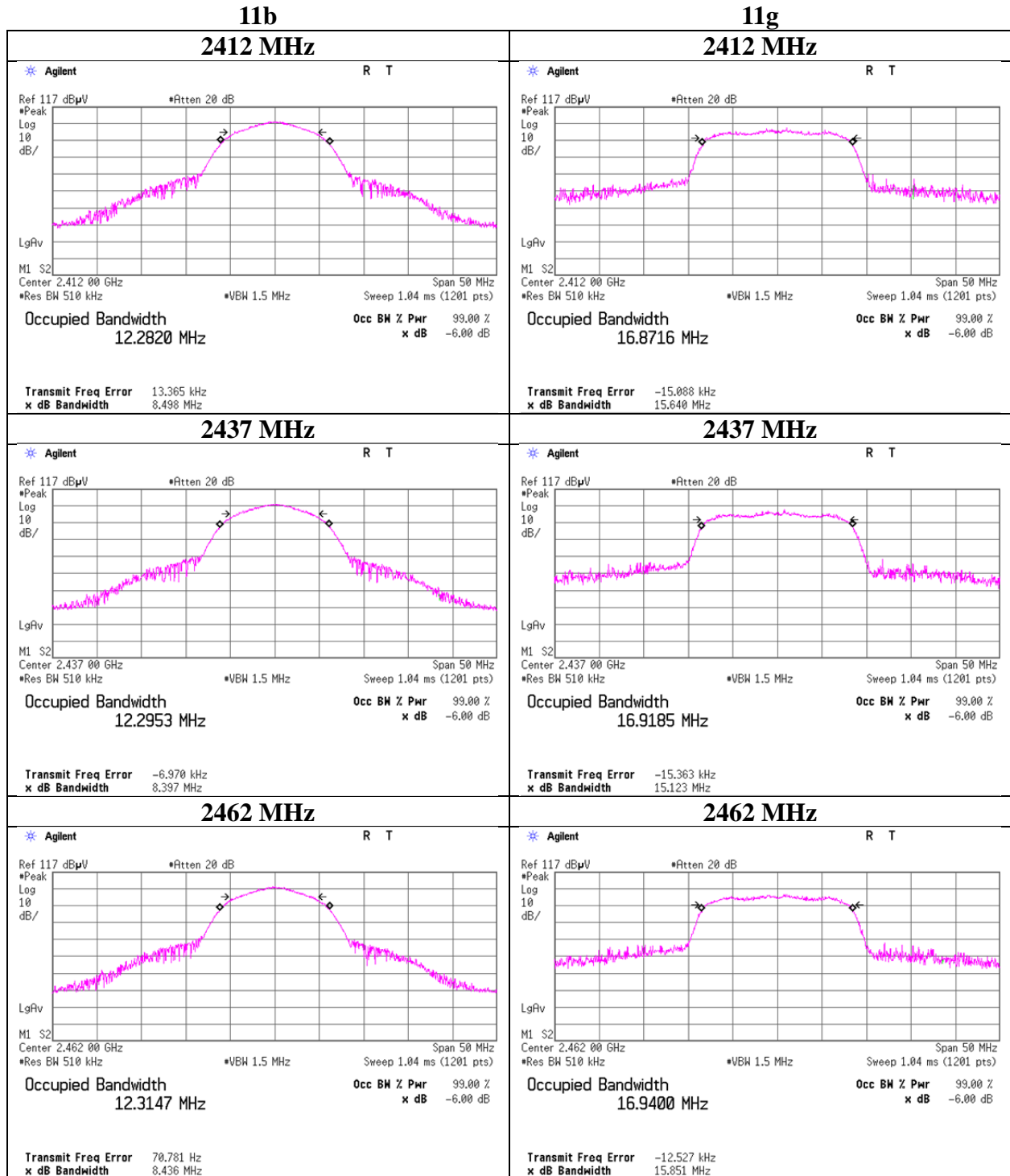

UL Japan, Inc.

Ise EMC Lab.

4383-326 Asama-cho, Ise-shi, Mie-ken 516-0021 JAPAN

Telephone : +81 596 24 8999

Facsimile : +81 596 24 8124

99% Occupied Bandwidth

Test place	Ise EMC Lab. No.11 Measurement Room
Report No.	11119465H
Date	January 11, 2016
Temperature / Humidity	22 deg. C / 31 % RH
Engineer	Shinichi Miyazono
Mode	Tx

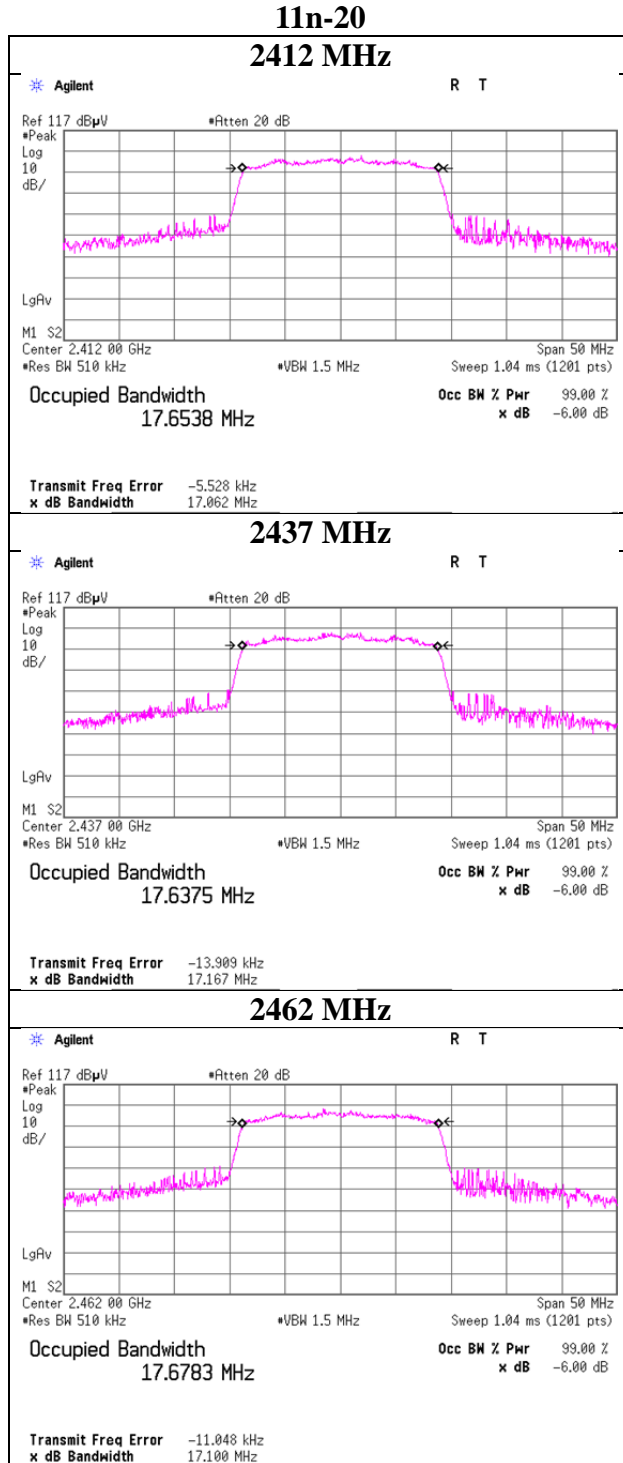

APPENDIX 2: Test instruments

Test equipment

Control No.	Instrument	Manufacturer	Model No	Serial No	Test Item	Calibration Date * Interval(month)
MAEC-03	Semi Anechoic Chamber(NSA)	TDK	Semi Anechoic Chamber 3m	DA-10005	RE/CE	2015/10/01 * 12
MOS-13	Thermo-Hygrometer	Custom	CTH-180	1301	RE/CE	2015/01/13 * 12
MJM-16	Measure	KOMELON	KMC-36	-	RE/CE	-
COTS-MEMI	EMI measurement program	TSJ	TEPTO-DV	-	RE/CE	-
MSA-03	Spectrum Analyzer	Agilent	E4448A	MY44020357	RE/CE	2015/05/18 * 12
MHA-20	Horn Antenna 1-18GHz	Schwarzbeck	BBHA9120D	258	RE	2015/05/18 * 12
MCC-167	Microwave Cable	Junkosha	MWX221	1404S374(1m) / 1405S074(5m)	RE	2015/05/21 * 12
MPA-11	MicroWave System Amplifier	Agilent	83017A	MY39500779	RE	2015/03/19 * 12
MHA-16	Horn Antenna 15-40GHz	Schwarzbeck	BBHA9170	BBHA9170306	RE	2015/05/19 * 12
MMM-08	DIGITAL HiTESTER	Hioki	3805	051201197	RE/CE	2015/01/16 * 12
MHF-25	High Pass Filter 3.5-18.0GHz	UL Japan	HPF SELECTOR	001	RE	2015/09/16 * 12
MTR-08	Test Receiver	Rohde & Schwarz	ESCI	100767	RE	2015/09/02 * 12
MBA-03	Biconical Antenna	Schwarzbeck	BBA9106	1915	RE	2015/10/11 * 12
MLA-03	Logperiodic Antenna	Schwarzbeck	USLP9143	174	RE	2015/10/11 * 12
MCC-51	Coaxial cable	UL Japan	-	-	RE	2015/07/13 * 12
MAT-70	Attenuator(6dB)	Agilent	8491A-006	MY52460153	RE	2015/04/08 * 12
MPA-13	Pre Amplifier	SONOMA INSTRUMENT	310	260834	RE	2015/03/10 * 12
MLS-23	LISN(AMN)	Schwarzbeck	NSLK8127	8127-729	CE(EUT)	2015/07/10 * 12
MLS-24	LISN(AMN)	Schwarzbeck	NSLK8127	8127-730	CE(AE)	2015/07/10 * 12
MTA-52	Terminator	TME	CT-01BP	-	CE	2015/12/01 * 12
MCC-112	Coaxial cable	Fujikura/Suhner/TSJ	5D-2W(10m)/SFM141(3m)/suciform141-PE(1m)/421-010(1.5m)/RFM-E321(Switcher)	-/00640	CE	2015/07/02 * 12
MAT-66	Attenuator(13dB)	JFW Industries, Inc.	50FP-013H2 N	-	CE	2015/01/29 * 12
MOS-19	Thermo-Hygrometer	Custom	CTH-201	0001	AT	2015/12/08 * 12
MBM-12	Barometer	Sunoh	SBR121	873	AT	2015/02/04 * 36
MSA-16	Spectrum Analyzer	Agilent	E4440A	MY46186390	AT	2015/02/16 * 12
MAT-25	Attenuator(10dB)(above 1GHz)	Agilent	8493C	71642	AT	2015/06/18 * 12
MPM-16	Power Meter	Agilent	8990B	MY51000271	AT	2015/04/01 * 12
MPSE-22	Power sensor	Agilent	N1923A	MY54070003	AT	2015/04/01 * 12
MCC-144	Microwave Cable	Junkosha	MWX221	1207S407	AT	2015/08/06 * 12
MMM-17	DIGITAL HiTESTER	Hioki	3805	070900530	AT	2015/01/16 * 12
MCC-38	Coaxial Cable	UL Japan	-	-	AT	2015/12/07 * 12
MAT-10	Attenuator(10dB)	Weinschel Corp	2	BL1173	AT	2015/11/10 * 12

The expiration date of the calibration is the end of the expired month.

All equipment is calibrated with valid calibrations. Each measurement data is traceable to the national or international standards.

As for some calibrations performed after the tested dates, those test equipment have been controlled by means of an unbroken chains of calibrations.

Test Item: CE: Conducted Emission test
RE: Radiated Emission test
AT: Antenna Terminal Conducted test

UL Japan, Inc.

Ise EMC Lab.

4383-326 Asama-cho, Ise-shi, Mie-ken 516-0021 JAPAN

Telephone : +81 596 24 8999

Facsimile : +81 596 24 8124