



# RADIO TEST REPORT

Test Report No. : 10602907H-A

**Applicant** : Murata Manufacturing Company, Ltd.  
**Type of Equipment** : Communication Module  
**Model No.** : Type1AD  
**FCC ID** : VPYLB1AD  
**Test regulation** : FCC Part 15 Subpart C: 2014  
**Test Result** : Complied

1. This test report shall not be reproduced in full or partial, without the written approval of UL Japan, Inc.
2. The results in this report apply only to the sample tested.
3. This sample tested is in compliance with the above regulation.
4. The test results in this report are traceable to the national or international standards.
5. This test report must not be used by the customer to claim product certification, approval, or endorsement by NVLAP, NIST, or any agency of the Federal Government.
6. This test report covers Radio technical requirements. It does not cover administrative issues such as Manual or non-Radio test related Requirements. (if applicable)

**Date of test:** December 9 to 16, 2014

**Representative test engineer:**

*T. Shimada*  
Takumi Shimada  
Engineer  
Consumer Technology Division

**Approved by:**

*Takayuki Shimada*  
Takayuki Shimada  
Engineer  
Consumer Technology Division



NVLAP LAB CODE: 200572-0

This laboratory is accredited by the NVLAP LAB CODE 200572-0, U.S.A. The tests reported herein have been performed in accordance with its terms of accreditation. \*As for the range of Accreditation in NVLAP, you may refer to the WEB address, <http://www.ul.com/japan/jpn/pages/services/emc/about/mark1/index.jsp#nvlap>

**UL Japan, Inc.**

**Ise EMC Lab.**

4383-326 Asama-cho, Ise-shi, Mie-ken 516-0021 JAPAN

Telephone : +81 596 24 8999

Facsimile : +81 596 24 8124

13-EM-F0429



---

<b>CONTENTS</b>	<b>PAGE</b>
<b>SECTION 1: Customer information</b> .....	<b>4</b>
<b>SECTION 2: Equipment under test (E.U.T.)</b> .....	<b>4</b>
<b>SECTION 3: Test specification, procedures &amp; results</b> .....	<b>5</b>
<b>SECTION 4: Operation of E.U.T. during testing</b> .....	<b>8</b>
<b>SECTION 5: Conducted Emission</b> .....	<b>11</b>
<b>SECTION 6: Radiated Spurious Emission</b> .....	<b>12</b>
<b>SECTION 7: Antenna Terminal Conducted Tests</b> .....	<b>14</b>
<b>APPENDIX 1: Data of EMI test</b> .....	<b>15</b>
Conducted Emission .....	15
6dB Bandwidth .....	16
Maximum Peak Output Power .....	19
Average Output Power .....	22
Radiated Spurious Emission .....	23
Conducted Spurious Emission .....	33
Power Density .....	34
99% Occupied Bandwidth .....	38
<b>APPENDIX 2: Test instruments</b> .....	<b>40</b>
<b>APPENDIX 3: Photographs of test setup</b> .....	<b>41</b>
Conducted Emission .....	41
Radiated Spurious Emission .....	42
Worst Case Position (Horizontal: Z-axis/ Vertical:Z-axis).....	43

## **SECTION 1: Customer information**

Company Name : Murata Manufacturing Company, Ltd.  
Address : 10-1, Higashikotari 1-chome, Nagaokakyo-shi, Kyoto 617-8555 Japan  
Telephone Number : +81-75-955-6604  
Facsimile Number : +81-75-955-6634  
Contact Person : Karun Malhotra

## **SECTION 2: Equipment under test (E.U.T.)**

### **2.1 Identification of E.U.T.**

Type of Equipment : Communication Module  
Model No. : Type1AD  
Serial No. : Refer to Section 4, Clause 4.2  
Rating : DC 3.3V  
Receipt Date of Sample : December 6, 2014  
Country of Mass-production : Japan, China  
Condition of EUT : Engineering prototype  
(Not for Sale: This sample is equivalent to mass-produced items.)  
Modification of EUT : No Modification by the test lab

### **2.2 Product Description**

#### **General Specification**

Clock frequency(ies) in the system : 37.4MHz

#### **Specification of WLAN (IEEE802.11b/g/n)**

Type of radio	Wireless LAN (IEEE802.11b/g)	Wireless LAN (IEEE802.11n) 2.4G Band SISO (20M Band)
Equipment Type	Transceiver	
Frequency of Operation	2412MHz - 2462MHz	
Bandwidth & Channel spacing	Bandwidth : 20MHz Ch spacing : 5MHz	
Type of Modulation	11b: DSSS 11g: OFDM	OFDM
Antenna Type / Antenna Gain	Monopole Antenna: -1.8dBi	
Power Supply (inner)	DC 3.3V	
Operating temperature range	-20 to +70 deg. C	

**UL Japan, Inc.**

**Ise EMC Lab.**

4383-326 Asama-cho, Ise-shi, Mie-ken 516-0021 JAPAN

Telephone : +81 596 24 8999

Facsimile : +81 596 24 8124

## **SECTION 3: Test specification, procedures & results**

### **3.1 Test Specification**

Test Specification : FCC Part 15 Subpart C: 2014, final revised on December 23, 2014

Title : FCC 47CFR Part15 Radio Frequency Device Subpart C Intentional Radiators  
Section 15.207 Conducted limits  
Section 15.247 Operation within the bands 902-928MHz,  
2400-2483.5MHz, and 5725-5850MHz

\* The revision on December 23, 2014 does not affect the test specification applied to the EUT.

### **3.2 Procedures and results**

Item	Test Procedure	Specification	Worst margin	Results	Remarks
Conducted Emission	FCC: ANSI C63.4:2003 7. AC powerline Conducted Emission measurements ----- IC: RSS-Gen 8.8	FCC: Section 15.207 ----- IC: RSS-Gen 8.8	QP 9.4dB, 7.11820MHz, N AV 5.7dB, 7.11820MHz, N	Complied	-
6dB Bandwidth	FCC: "Guidance for Performing Compliance Measurements on Digital Transmission Systems (DTS) Operating Under §15.247(issued on June 5, 2014)" ----- IC: -	FCC: Section 15.247(a)(2) ----- IC: RSS-210 A8.2(a)	See data.	Complied	Conducted
Maximum Peak Output Power	FCC: "Guidance for Performing Compliance Measurements on Digital Transmission Systems (DTS) Operating Under §15.247(issued on June 5, 2014)" ----- IC: RSS-Gen 6.12	FCC: Section 15.247(b)(3) ----- IC: RSS-210 A8.4(4)		Complied	Conducted
Power Density	FCC: "Guidance for Performing Compliance Measurements on Digital Transmission Systems (DTS) Operating Under §15.247(issued on June 5, 2014)" ----- IC: -	FCC: Section 15.247 (e) ----- IC: RSS-210 A8.2(b)		Complied	Conducted
Spurious Emission Restricted Band Edges	FCC: "Guidance for Performing Compliance Measurements on Digital Transmission Systems (DTS) Operating Under §15.247(issued on June 5, 2014)" ----- IC: RSS-Gen 6.13	FCC: Section15.247(d) ----- IC: RSS-210 A8.5 RSS-Gen 8.9 RSS-Gen 8.10		2.0dB 4874.000MHz AV, Horizontal	Complied

Note: UL Japan, Inc.'s EMI Work Procedures No. 13-EM-W0420 and 13-EM-W0422.

\* In case any questions arise about test procedure, ANSI C63.4: 2003 is also referred.

#### **FCC 15.31 (e)**

The EUT has the power supply regulator. However one of the input voltages to RF part doesn't go through the regulator. The stable voltage will be supplied by the end product, which will be required to have a power supply regulator. Therefore, the EUT complies with the requirement.

#### **FCC Part 15.203/212 Antenna requirement**

It is impossible for end users to replace the antenna, because it is soldered on the circuit board. Therefore, the equipment complies with the antenna requirement of Section 15.203/212.

### **UL Japan, Inc.**

#### **Ise EMC Lab.**

4383-326 Asama-cho, Ise-shi, Mie-ken 516-0021 JAPAN

Telephone : +81 596 24 8999

Facsimile : +81 596 24 8124

### 3.3 Addition to standard

Item	Test Procedure	Specification	Worst margin	Results	Remarks
99% Occupied Bandwidth	IC: RSS-Gen 6.6	IC: -	N/A	-	Conducted

Other than above, no addition, exclusion nor deviation has been made from the standard.

### 3.4 Uncertainty

#### EMI

The following uncertainties have been calculated to provide a confidence level of 95% using a coverage factor k=2.

Test room (semi-anechoic chamber)	Conducted emission (+dB)
	150kHz-30MHz
No.1	3.5dB
No.2	3.5dB
No.3	3.6dB
No.4	3.5dB

Test room (semi-anechoic chamber)	Radiated emission						
	(3m*)(+dB)				(1m*)(+dB)		(0.5m*)(+dB)
	9kHz -30MHz	30MHz -300MHz	300MHz -1GHz	1GHz -10GHz	10GHz -18GHz	18GHz -26.5GHz	26.5GHz -40GHz
No.1	4.0dB	5.1dB	5.0dB	5.1dB	6.0dB	4.9dB	4.3dB
No.2	3.9dB	5.2dB	5.0dB	4.9dB	5.9dB	4.7dB	4.2dB
No.3	4.3dB	5.1dB	5.2dB	5.2dB	6.0dB	4.8dB	4.2dB
No.4	4.6dB	5.2dB	5.0dB	5.2dB	6.0dB	5.7dB	4.2dB

\*3m/1m/0.5m = Measurement distance

Power meter (+dB)	
Below 1GHz	Above 1GHz
0.7dB	1.5dB

Antenna terminal conducted emission and Power density (+dB)			Antenna terminal conducted emission (+dB)		Channel power (+dB)
Below 1GHz	1GHz-3GHz	3GHz-18GHz	18GHz-26.5GHz	26.5GHz-40GHz	
1.5dB	1.7dB	2.8dB	2.8dB	2.9dB	2.6dB

#### Conducted Emission test

The data listed in this test report has enough margin, more than the site margin.

#### Radiated emission test (3m)

The data listed in this report meets the limits unless the uncertainty is taken into consideration.

**UL Japan, Inc.**

**Ise EMC Lab.**

4383-326 Asama-cho, Ise-shi, Mie-ken 516-0021 JAPAN

Telephone : +81 596 24 8999

Facsimile : +81 596 24 8124

### 3.5 Test Location

UL Japan, Inc. Ise EMC Lab. \*NVLAP Lab. code: 200572-0  
4383-326 Asama-cho, Ise-shi, Mie-ken 516-0021 JAPAN  
Telephone : +81 596 24 8999 Facsimile : +81 596 24 8124

	IC Registration Number	Width x Depth x Height (m)	Size of reference ground plane (m) / horizontal conducting plane	Other rooms
No.1 semi-anechoic chamber	2973C-1	19.2 x 11.2 x 7.7m	7.0 x 6.0m	No.1 Power source room
No.2 semi-anechoic chamber	2973C-2	7.5 x 5.8 x 5.2m	4.0 x 4.0m	-
No.3 semi-anechoic chamber	2973C-3	12.0 x 8.5 x 5.9m	6.8 x 5.75m	No.3 Preparation room
No.3 shielded room	-	4.0 x 6.0 x 2.7m	N/A	-
No.4 semi-anechoic chamber	2973C-4	12.0 x 8.5 x 5.9m	6.8 x 5.75m	No.4 Preparation room
No.4 shielded room	-	4.0 x 6.0 x 2.7m	N/A	-
No.5 semi-anechoic chamber	-	6.0 x 6.0 x 3.9m	6.0 x 6.0m	-
No.6 shielded room	-	4.0 x 4.5 x 2.7m	4.0 x 4.5 m	-
No.6 measurement room	-	4.75 x 5.4 x 3.0m	4.75 x 4.15 m	-
No.7 shielded room	-	4.7 x 7.5 x 2.7m	4.7 x 7.5m	-
No.8 measurement room	-	3.1 x 5.0 x 2.7m	N/A	-
No.9 measurement room	-	8.0 x 4.6 x 2.8m	2.4 x 2.4m	-
No.11 measurement room	-	6.2 x 4.7 x 3.0m	4.8 x 4.6m	-

\* Size of vertical conducting plane (for Conducted Emission test) : 2.0 x 2.0m for No.1, No.2, No.3, and No.4 semi-anechoic chambers and No.3 and No.4 shielded rooms.

### 3.6 Data of EMI, Test instruments, and Test set up

Refer to APPENDIX.

## UL Japan, Inc. Ise EMC Lab.

4383-326 Asama-cho, Ise-shi, Mie-ken 516-0021 JAPAN  
Telephone : +81 596 24 8999  
Facsimile : +81 596 24 8124

## **SECTION 4: Operation of E.U.T. during testing**

### **4.1 Operating Mode(s)**

Test operating mode was determined as follows according to “Section 1 of 6 802.11 a/b/g/n testing - Managing Complex Regulatory Approvals - ” of TCB Council Workshop October 2009.

<b>Mode</b>	<b>Remarks*</b>
IEEE 802.11b (11b)	11Mbps, PN9
IEEE 802.11g (11g)	48bps, PN9
IEEE 802.11n SISO 20MHz BW (11n-20)	MCS 3, PN9
*The worst condition was determined based on the test result of Maximum Peak Output Power (Mid Channel)	
*Power of the EUT was set by the software as follows; Power settings: 11b: 17dBm, 11g: 13dBm, 11n-20: 12dBm Software: version 5.90.230.2 *This setting of software is the worst case. Any conditions under the normal use do not exceed the condition of setting. In addition, end users cannot change the settings of the output power of the product.	

\*The details of Operating mode(s)

<b>Test Item</b>	<b>Operating Mode</b>	<b>Tested frequency</b>
Conducted Emission Spurious Emission (Conducted)	11g Tx *1)	2462MHz *1)
Spurious Emission (Radiated)	11b Tx 11g Tx	2412MHz 2437MHz 2462MHz
	11n-20 Tx *2)	2412MHz 2462MHz
6dB Bandwidth, Maximum Peak Output Power, Power Density, 99% Occupied Bandwidth	11b Tx 11g Tx 11n-20 Tx	2412MHz 2437MHz 2462MHz
*1) The test was performed on the representative mode/frequency that had the highest power at antenna terminal test. *2) Only band edge was tested on this mode according to “Section 1 of 6 802.11 a/b/g/n testing- Managing Complex Regulatory Approvals - ” of TCB Council Workshop October 2009, as the 11g Tx mode had the higher power at antenna terminal test.		

**UL Japan, Inc.**  
**Ise EMC Lab.**

4383-326 Asama-cho, Ise-shi, Mie-ken 516-0021 JAPAN  
Telephone : +81 596 24 8999  
Facsimile : +81 596 24 8124



## 4.2 Configuration and peripherals

### Conducted emission test

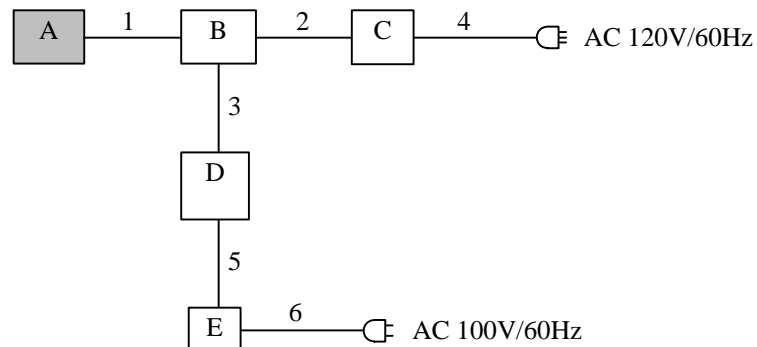

\* Cabling and setup(s) were taken into consideration and test data was taken under worse case conditions.

### Description of EUT

No.	Item	Model number	Serial number	Manufacturer	Remarks
A	Communication Module	Type1AD	1	Murata Manufacturing Company, Ltd.	EUT
B	Jig	-	-	Murata Manufacturing Company, Ltd.	-
C	DC Power Supply	PMC35-2A	13090501	KIKUSUI	-
D	Laptop PC	CF-W5	7HKSA86870	Panasonic	-
E	AC Adapter	CF-AA6282A	6282AM107619146A	Panasonic	-

### List of cables used

No.	Name	Length (m)	Shield		Remarks
			Cable	Connector	
1	Flat Cable	0.1	Unshielded	Unshielded	-
2	DC Cable	1.0	Unshielded	Unshielded	-
3	USB Cable	2.0	Shielded	Shielded	-
4	AC Cable	0.8	Unshielded	Unshielded	-
5	DC Cable	1.5	Unshielded	Unshielded	-
6	AC Cable	0.9	Unshielded	Unshielded	-

**UL Japan, Inc.**

**Ise EMC Lab.**

4383-326 Asama-cho, Ise-shi, Mie-ken 516-0021 JAPAN

Telephone : +81 596 24 8999

Facsimile : +81 596 24 8124

**Radiated emission and Antenna terminal conducted tests**

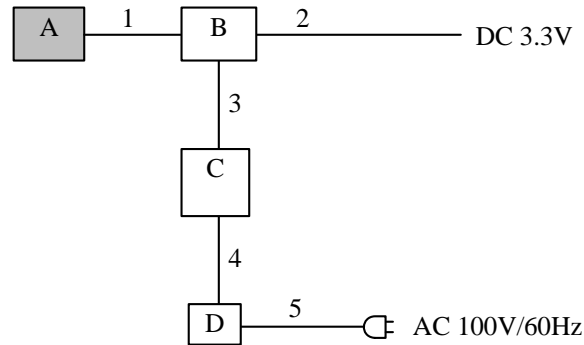

\* Cabling and setup(s) were taken into consideration and test data was taken under worse case conditions.

**Description of EUT**

No.	Item	Model number	Serial number	Manufacturer	Remarks
A	Communication Module	Type1AD	1	Murata Manufacturing Company, Ltd.	EUT
B	Jig	-	-	Murata Manufacturing Company, Ltd.	-
C	Laptop PC	FMV-C8230	R7305017	FUJITSU	-
D	AC Adapter	FMV-AC312	CA1007-0930	FUJITSU	-

**List of cables used**

No.	Name	Length (m)	Shield		Remarks
			Cable	Connector	
1	Flat Cable	0.1	Unshielded	Unshielded	-
2	DC Cable	3.0	Unshielded	Unshielded	-
3	USB Cable	2.0	Shielded	Shielded	-
4	DC Cable	1.8	Unshielded	Unshielded	-
5	AC Cable	2.0	Unshielded	Unshielded	-

**UL Japan, Inc.**

**Ise EMC Lab.**

4383-326 Asama-cho, Ise-shi, Mie-ken 516-0021 JAPAN

Telephone : +81 596 24 8999

Facsimile : +81 596 24 8124

## **SECTION 5: Conducted Emission**

### **Test Procedure and conditions**

EUT was placed on a wooden table of nominal size, 1.0m by 1.5m, raised 0.8m above the conducting ground plane. The rear of tabletop was located 40cm to the vertical conducting plane. The rear of EUT, including peripherals aligned and flushed with rear of tabletop. All other surfaces of tabletop were at least 80cm from any other grounded conducting surface. EUT was located 80cm from a Line Impedance Stabilization Network (LISN)/ Artificial mains Network (AMN) and excess AC cable was bundled in center.

For the tests on EUT with other peripherals (as a whole system)

I/O cables that were connected to the peripherals were bundled in center. They were folded back and forth forming a bundle 30cm to 40cm long and were hanged at a 40cm height to the ground plane. All unused 50ohm connectors of the LISN(AMN) were resistivity terminated in 50ohm when not connected to the measuring equipment.

The AC Mains Terminal Continuous disturbance Voltage has been measured with the EUT in a Semi Anechoic Chamber.

The EUT was connected to a LISN (AMN).

An overview sweep with peak detection has been performed.

The test results and limit are rounded off to one decimal place, so some differences might be observed.

<b>Detector</b>	<b>: QP and CISPR AV</b>
<b>Measurement range</b>	<b>: 0.15-30MHz</b>
<b>Test data</b>	<b>: APPENDIX</b>
<b>Test result</b>	<b>: Pass</b>

---

**UL Japan, Inc.**

**Ise EMC Lab.**

4383-326 Asama-cho, Ise-shi, Mie-ken 516-0021 JAPAN

Telephone : +81 596 24 8999

Facsimile : +81 596 24 8124

## **SECTION 6: Radiated Spurious Emission**

### **Test Procedure**

It was measured based on "11.0 Emissions in non-restricted frequency bands" of "558074 D01 DTS Meas Guidance v03r02 (Issued on June 5, 2014)".

EUT was placed on a urethane platform of nominal size, 0.5m by 1.0m, raised 0.8m above the conducting ground plane.

The Radiated Electric Field Strength has been measured in a Semi Anechoic Chamber with a ground plane.

The height of the measuring antenna varied between 1 and 4m and EUT was rotated a full revolution in order to obtain the maximum value of the electric field strength.

The measurements were performed for both vertical and horizontal antenna polarization with the Test Receiver, or the Spectrum Analyzer.

The measurements were made with the following detector function of the test receiver and the Spectrum analyzer (in linear mode).

The test was made with the detector (RBW/VBW) in the following table.

When using Spectrum analyzer, the test was made with adjusting span to zero by using peak hold.

### **Test Antennas are used as below;**

Frequency	Below 30MHz	30MHz to 300MHz	300MHz to 1GHz	Above 1GHz
Antenna Type	Loop	Biconical	Logperiodic	Horn

In any 100kHz bandwidth outside the restricted band in which the spread spectrum intentional radiator is operating, the radio frequency power that is produced by the intentional radiator confirmed 20dB below that in the 100kHz bandwidth within the band that contains the highest level of the desired power, based on a radiated measurement.

### **20dBc was applied to the frequency over the limit of FCC 15.209 / Table 4 of RSS-Gen 8.9(IC) and outside the restricted band of FCC15.205 / Table 6 of RSS-Gen 8.10 (IC).**

Frequency	Below 1GHz	Above 1GHz		20dBc
Instrument used	Test Receiver	Spectrum Analyzer		Spectrum Analyzer
Detector	QP	PK	AV *1)	PK
IF Bandwidth	BW 120kHz	RBW: 1MHz VBW: 3MHz	Average Power Method: <u>WLAN: 12.2.5.1 (11b)</u> RBW: 1MHz VBW: 3MHz Detector: Power Averaging (RMS) Trace: Free Run <u>WLAN: 12.2.5.2 (11g/n-20)</u> RBW: 1MHz VBW: 3MHz Detector: Power Averaging (RMS) Trace: Free Run Duty factor was added to the results.	RBW: 100kHz VBW: 300kHz
Test Distance	3m	3m (below 10GHz), 1m *2) (above 10GHz)		3m (below 10GHz), 1m *2) (above 10GHz)

\*1) Average Power Measurement was performed based on 6.0 & 12.2.5 of "558074 D01 DTS Meas Guidance v03r02 (Issued on June 5, 2014)"

\*2) Distance Factor:  $20 \times \log(3.0\text{m}/1.0\text{m}) = 9.5\text{dB}$

**UL Japan, Inc.**

**Ise EMC Lab.**

4383-326 Asama-cho, Ise-shi, Mie-ken 516-0021 JAPAN

Telephone : +81 596 24 8999

Facsimile : +81 596 24 8124

- The carrier level and noise levels were confirmed at each position of X, Y and Z axes of EUT to see the position of maximum noise, and the test was made at the position that has the maximum noise.

The test results and limit are rounded off to one decimal place, so some differences might be observed.

**Measurement range** : 30M-26.5GHz  
**Test data** : APPENDIX  
**Test result** : Pass

---

**UL Japan, Inc.**

**Ise EMC Lab.**

4383-326 Asama-cho, Ise-shi, Mie-ken 516-0021 JAPAN

Telephone : +81 596 24 8999

Facsimile : +81 596 24 8124

## **SECTION 7: Antenna Terminal Conducted Tests**

### **Test Procedure**

The tests were made with below setting connected to the antenna port.

<b>Test</b>	<b>Span</b>	<b>RBW</b>	<b>VBW</b>	<b>Sweep time</b>	<b>Detector</b>	<b>Trace</b>	<b>Instrument used</b>
6dB Bandwidth	20MHz	100kHz	300kHz	Auto	Peak	Max Hold	Spectrum Analyzer
99% Occupied Bandwidth	Enough width to display 20dB Bandwidth	1 to 3% of Span	Three times of RBW	Auto	Peak	Max Hold*1)	Spectrum Analyzer
Maximum Peak Output Power	-	-	-	Auto	Peak/Average *2)	-	Power Meter (Sensor: 50MHz BW)
Peak Power Density	1.5 times the 6dB Bandwidth	3kHz	10kHz	Auto	Peak	Max Hold	Spectrum Analyzer *3)
Conducted Spurious Emission *4)	9kHz to 150kHz	200Hz	620Hz	Auto	Peak	Max Hold	Spectrum Analyzer
	150kHz to 30MHz	9.1kHz	27kHz				
*1) The measurement was performed with Max Hold since the duty cycle was not 100%. *2) Reference data *3) Section 10.2 Method PKPSD (peak PSD) of "558074 D01 DTS Meas Guidance v03r02 (Issued on June 5, 2014)". *4) In the frequency range below 30MHz, RBW was narrowed to separate the noise contents. Then, wide-band noise near the limit was checked separately, however the noise was low enough as shown in the chart.(9kHz-150kHz:RBW=200Hz, 150kHz-30MHz:RBW=9.1kHz).							

The test results and limit are rounded off to two decimals place, so some differences might be observed.

**Test data** : **APPENDIX**  
**Test result** : **Pass**

**APPENDIX 1: Data of EMI test**

**Conducted Emission**

**DATA OF CONDUCTED EMISSION TEST**

UL Japan, Inc. Ise EMC Lab. No.2 Semi Anechoic Chamber  
Date: 2014/12/16

Report No. : 10602907H  
Power : AC 120V / 60Hz  
Temp./Humi. : 23deg. C / 29% RH  
Engineer : Yuta Moriya

Mode / Remarks : Tx 11g 48Mbps 2462MHz

LIMIT : FCC15.207 QP  
FCC15.207 AV

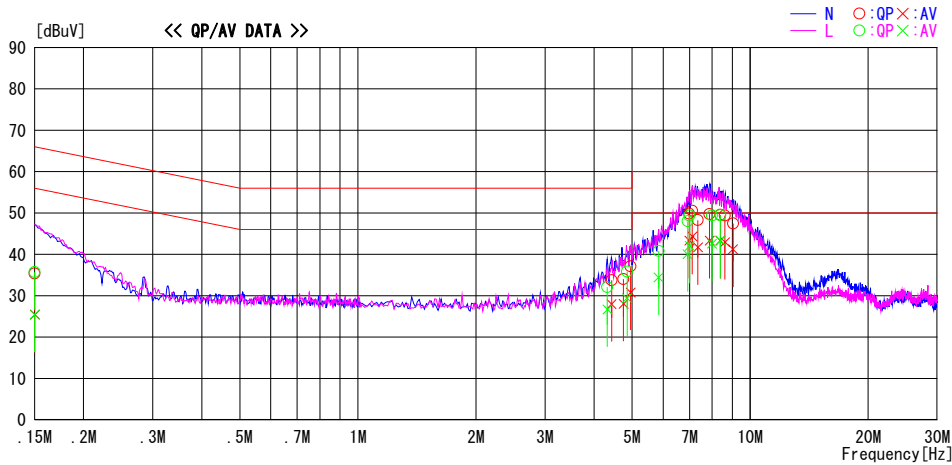

Frequency [MHz]	Reading Level		Corr. Factor [dB]	Results		Limit		Margin		Phase
	QP [dBuV]	AV [dBuV]		QP [dBuV]	AV [dBuV]	QP [dBuV]	AV [dBuV]	QP [dB]	AV [dB]	
0.15000	22.2	12.2	13.2	35.4	25.4	66.0	56.0	30.6	30.6	N
0.15000	22.5	12.3	13.2	35.7	25.5	66.0	56.0	30.3	30.5	L
4.32420	18.4	13.0	13.7	32.1	26.7	56.0	46.0	23.9	19.3	L
4.43200	20.0	14.3	13.7	33.7	28.0	56.0	46.0	22.3	18.0	N
4.75280	20.2	14.3	13.8	34.0	28.1	56.0	46.0	22.0	17.9	N
4.85310	22.0	15.6	13.8	35.8	29.4	56.0	46.0	20.2	16.6	L
4.95700	23.3	17.0	13.8	37.1	30.8	56.0	46.0	18.9	15.2	N
5.84000	26.9	20.5	13.9	40.8	34.4	60.0	50.0	19.2	15.6	L
6.92600	34.0	26.1	14.0	48.0	40.1	60.0	50.0	12.0	9.9	L
6.99470	35.8	29.3	14.0	49.8	43.3	60.0	50.0	10.2	6.7	N
7.00640	35.4	28.1	14.0	49.4	42.1	60.0	50.0	10.6	7.9	L
7.11820	36.6	30.3	14.0	50.6	44.3	60.0	50.0	9.4	5.7	N
7.36107	34.3	27.7	14.0	48.3	41.7	60.0	50.0	11.7	8.3	N
7.87500	35.7	29.3	14.0	49.7	43.3	60.0	50.0	10.3	6.7	N
7.99000	35.4	28.6	14.0	49.4	42.6	60.0	50.0	10.6	7.4	L
8.39424	35.5	29.2	14.1	49.6	43.3	60.0	50.0	10.4	6.7	N
8.40100	35.4	29.2	14.1	49.5	43.3	60.0	50.0	10.5	6.7	L
8.62692	35.3	28.9	14.1	49.4	43.0	60.0	50.0	10.6	7.0	N
9.04400	33.3	27.0	14.2	47.5	41.2	60.0	50.0	12.5	8.8	N

CHART : WITH FACTOR. Peak hold data. CALCULATION : RESULT = READING + C.F (LISN + ATTEN + CABLE)  
Except for the above table : adequate margin data below the limits.

**UL Japan, Inc.**  
**Ise EMC Lab.**

4383-326 Asama-cho, Ise-shi, Mie-ken 516-0021 JAPAN

Telephone : +81 596 24 8999

Facsimile : +81 596 24 8124

## 6dB Bandwidth

Test place	Ise EMC Lab. No.11 Measurement Room
Report No.	10602907H
Date	12/11/2014
Temperature/ Humidity	24 deg. C / 29% RH
Engineer	Takumi Shimada
Mode	Tx

11b

Frequency [MHz]	6dB Bandwidth [MHz]	Limit [kHz]
2412	8.507	>500
2437	8.870	>500
2462	9.264	>500

11g

Frequency [MHz]	6dB Bandwidth [MHz]	Limit [kHz]
2412	16.481	>500
2437	16.478	>500
2462	16.482	>500

11n-20

Frequency [MHz]	6dB Bandwidth [MHz]	Limit [kHz]
2412	17.785	>500
2437	17.758	>500
2462	17.759	>500



**6dB Bandwidth**

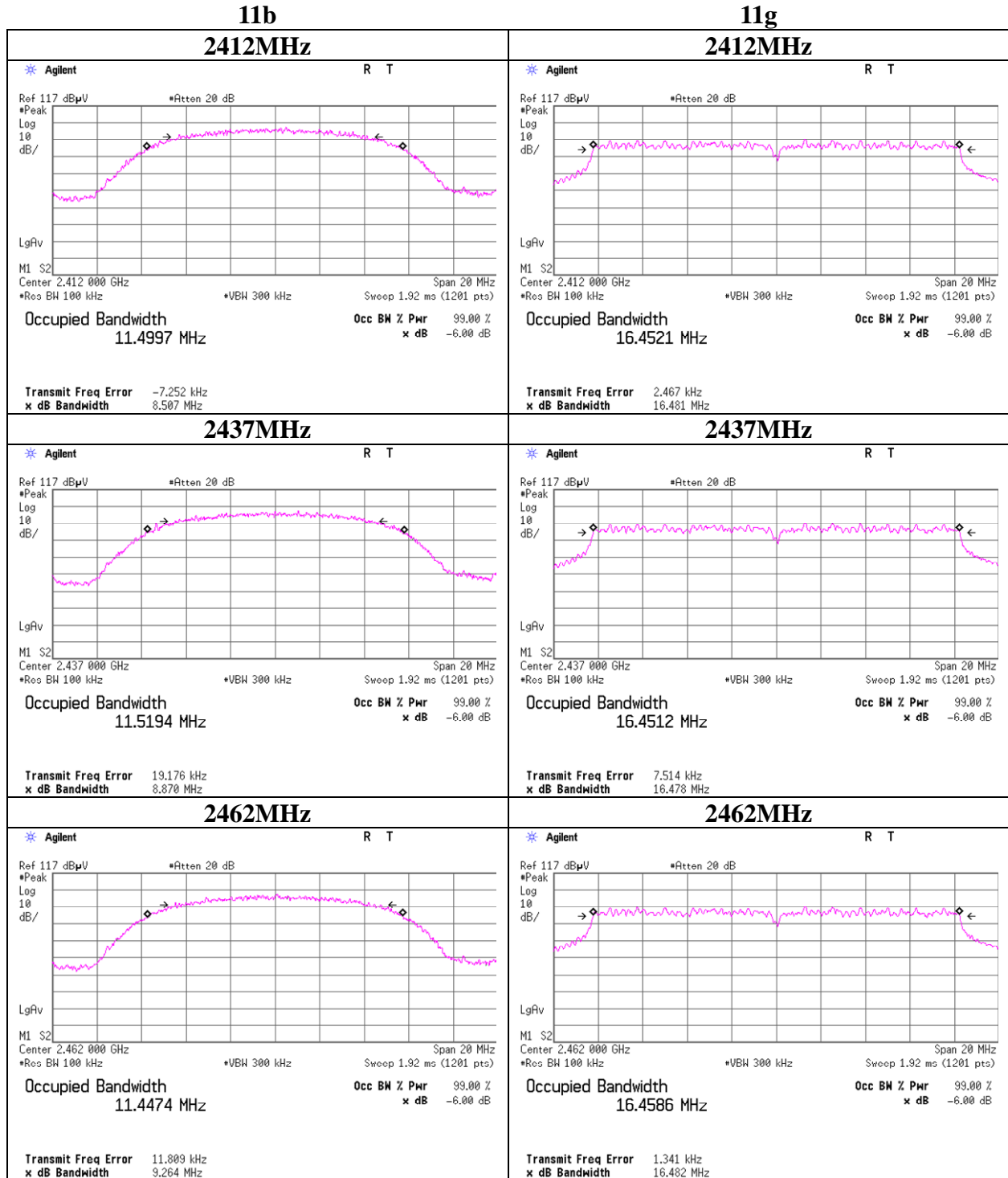

## 6dB Bandwidth

**11n-20**

**2412MHz**

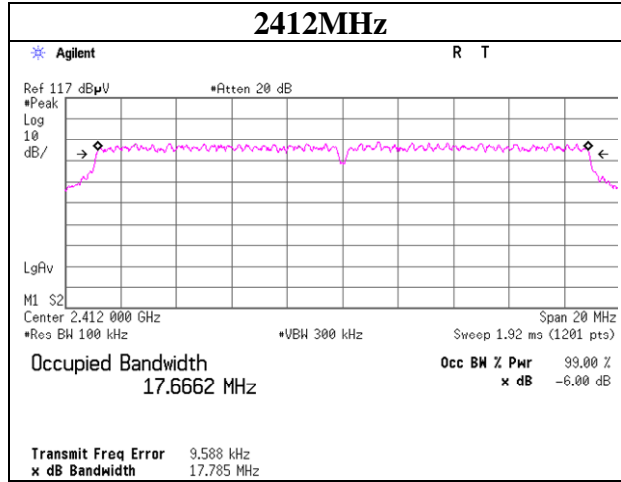

**2437MHz**

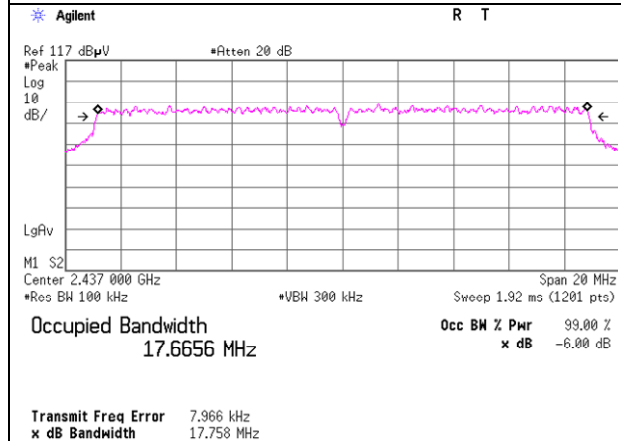

**2462MHz**

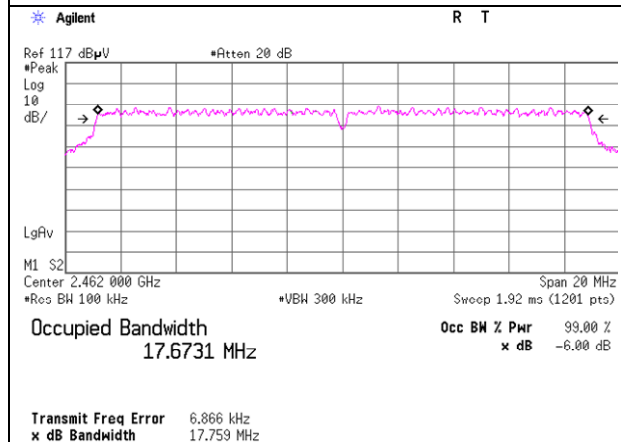

**UL Japan, Inc.**  
**Ise EMC Lab.**

4383-326 Asama-cho, Ise-shi, Mie-ken 516-0021 JAPAN

Telephone : +81 596 24 8999

Facsimile : +81 596 24 8124

### Maximum Peak Output Power

Test place	Ise EMC Lab. No.3 Measurement Room
Report No.	10602907H
Date	12/09/2014
Temperature/ Humidity	24deg. C / 32% RH
Engineer	Takumi Shimada
Mode	11b Tx

Freq. [MHz]	Reading [dBm]	Cable Loss [dB]	Atten. [dB]	Result		Limit		Margin [dB]
				[dBm]	[mW]	[dBm]	[mW]	
2412	8.75	1.78	10.02	20.55	113.50	30.00	1000	9.45
2437	9.02	1.79	10.02	20.83	121.06	30.00	1000	9.17
2462	9.11	1.80	10.02	20.93	123.88	30.00	1000	9.07

Sample Calculation:

Result = Reading + Cable Loss (including the cable(s) customer supplied) + Attenuator

2437MHz

Rate	Reading	Remark
[Mbps]	[dBm]	
1	8.42	
2	8.73	
5.5	8.63	
11	9.02	*

\*: Worst Rate

All comparizon were carried out on same frequency and measurement factors.

**UL Japan, Inc.**

**Ise EMC Lab.**

4383-326 Asama-cho, Ise-shi, Mie-ken 516-0021 JAPAN

Telephone : +81 596 24 8999

Facsimile : +81 596 24 8124

### Maximum Peak Output Power

Test place	Ise EMC Lab. No.3 Measurement Room
Report No.	10602907H
Date	12/09/2014
Temperature/ Humidity	24deg. C / 32% RH
Engineer	Takumi Shimada
Mode	11g Tx

Freq. [MHz]	Reading [dBm]	Cable Loss [dB]	Atten. [dB]	Result		Limit		Margin [dB]
				[dBm]	[mW]	[dBm]	[mW]	
2412	10.73	1.78	10.02	22.53	179.06	30.00	1000	7.47
2437	11.02	1.79	10.02	22.83	191.87	30.00	1000	7.17
2462	11.10	1.80	10.02	22.92	195.88	30.00	1000	7.08

Sample Calculation:

Result = Reading + Cable Loss (including the cable(s) customer supplied) + Attenuator

2437MHz

Rate	Reading	Remark
[Mbps]	[dBm]	
6	8.21	
9	8.25	
12	8.00	
18	8.05	
24	10.43	
36	10.74	
48	11.02	*
54	10.32	

\*: Worst Rate

All comparison were carried out on same frequency and measurement factors.

**UL Japan, Inc.**

**Ise EMC Lab.**

4383-326 Asama-cho, Ise-shi, Mie-ken 516-0021 JAPAN

Telephone : +81 596 24 8999

Facsimile : +81 596 24 8124

### Maximum Peak Output Power

Test place	Ise EMC Lab. No.3 Measurement Room
Report No.	10602907H
Date	12/09/2014
Temperature/ Humidity	24deg. C / 32% RH
Engineer	Takumi Shimada
Mode	11n-20 Tx

Freq. [MHz]	Reading [dBm]	Cable Loss [dB]	Atten. [dB]	Result		Limit		Margin [dB]
				[dBm]	[mW]	[dBm]	[mW]	
2412	10.26	1.78	10.02	22.06	160.69	30.00	1000	7.94
2437	10.44	1.79	10.02	22.25	167.88	30.00	1000	7.75
2462	10.65	1.80	10.02	22.47	176.60	30.00	1000	7.53

Sample Calculation:

Result = Reading + Cable Loss (including the cable(s) customer supplied) + Attenuator

2437MHz

MCS Number	Reading [dBm]	Remark
0	7.7	
1	7.49	
2	7.64	
3	10.44	*
4	9.98	
5	10.13	
6	10.34	
7	10.22	

\*: Worst Rate

All comparison were carried out on same frequency and measurement factors.

**UL Japan, Inc.**

**Ise EMC Lab.**

4383-326 Asama-cho, Ise-shi, Mie-ken 516-0021 JAPAN

Telephone : +81 596 24 8999

Facsimile : +81 596 24 8124

## Average Output Power

Test place	Ise EMC Lab. No.3 Measurement Room
Report No.	10602907H
Date	12/09/2014
Temperature/ Humidity	24deg. C / 32% RH
Engineer	Takumi Shimada
Mode	11b/g/n-20 Tx

[AV]

11b **11Mbps**

Freq. [MHz]	Reading [dBm]	Cable Loss [dB]	Atten. [dB]	Result		Limit		Margin [dB]
				[dBm]	[mW]	[dBm]	[mW]	
2412	5.15	1.78	10.02	16.95	49.55	30.00	1000	13.05
2437	5.20	1.79	10.02	17.01	50.23	30.00	1000	12.99
2462	5.36	1.80	10.02	17.18	52.24	30.00	1000	12.82

11g **48Mbps**

Freq. [MHz]	Reading [dBm]	Cable Loss [dB]	Atten. [dB]	Result		Limit		Margin [dB]
				[dBm]	[mW]	[dBm]	[mW]	
2412	0.95	1.78	10.02	12.75	18.84	30.00	1000	17.25
2437	1.07	1.79	10.02	12.88	19.41	30.00	1000	17.12
2462	1.25	1.80	10.02	13.07	20.28	30.00	1000	16.93

11n-20 **MCS3**

Freq. [MHz]	Reading [dBm]	Cable Loss [dB]	Atten. [dB]	Result		Limit		Margin [dB]
				[dBm]	[mW]	[dBm]	[mW]	
2412	0.11	1.78	10.02	11.91	15.52	30.00	1000	18.09
2437	0.19	1.79	10.02	12.00	15.85	30.00	1000	18.00
2462	0.29	1.80	10.02	12.11	16.26	30.00	1000	17.89

Sample Calculation:

Result = Reading + Cable Loss (including the cable(s) customer supplied) + Attenuator













## Radiated Spurious Emission

Test place	Ise EMC Lab. No.3 Measurement Room		
Report No.	10602907H		
Date	12/13/2014	12/14/2014	12/14/2014
Temperature/ Humidity	23 deg. C / 39% RH	18 deg. C / 28% RH	18 deg. C / 28% RH
Engineer	Takumi Shimada	Keisuke Kawamura	Keisuke Kawamura
	(1-10GHz)	(Above 10GHz)	(Below 1GHz)
Mode	11g Tx 2462MHz		

Polarity	Frequency [MHz]	Detector	Reading [dBuV]	Ant.Fac. [dB/m]	Loss [dB]	Gain [dB]	Duty Factor [dB]	Result [dBuV/m]	Limit [dBuV/m]	Margin [dB]	Remark
Hori	166.606	QP	32.6	15.7	8.8	32.1	-	25.0	43.5	18.5	
Hori	240.003	QP	30.4	17.1	9.4	32.0	-	24.9	46.0	21.1	
Hori	364.969	QP	32.1	16.6	10.3	31.9	-	27.1	46.0	18.9	
Hori	433.191	QP	35.9	17.8	10.7	32.0	-	32.4	46.0	13.6	
Hori	479.973	QP	31.4	18.1	11.0	32.0	-	28.5	46.0	17.5	
Hori	499.857	QP	27.4	18.2	11.2	32.0	-	24.8	46.0	21.2	
Hori	2483.500	PK	58.1	26.9	3.2	32.7	-	55.5	73.9	18.4	
Hori	4924.000	PK	46.7	30.8	5.3	31.7	-	51.1	73.9	22.8	
Hori	7386.000	PK	42.5	35.9	6.5	32.7	-	52.2	73.9	21.7	Floor Noise
Hori	9848.000	PK	42.8	38.8	7.1	33.5	-	55.2	73.9	18.7	Floor Noise
Hori	2483.500	AV	47.3	26.9	3.2	32.7	0.4	45.1	53.9	8.8	*1)
Hori	4924.000	AV	37.8	30.8	5.3	31.7	0.4	42.6	53.9	11.3	
Hori	7386.000	AV	32.2	35.9	6.5	32.7	-	41.9	53.9	12.0	Floor Noise
Hori	9848.000	AV	33.6	38.8	7.1	33.5	-	46.0	53.9	7.9	Floor Noise
Vert	115.600	QP	41.0	12.3	8.2	32.1	-	29.4	43.5	14.1	
Vert	144.006	QP	35.1	14.6	8.5	32.1	-	26.1	43.5	17.4	
Vert	166.569	QP	38.7	15.7	8.8	32.1	-	31.1	43.5	12.4	
Vert	433.166	QP	39.0	17.8	10.7	32.0	-	35.5	46.0	10.5	
Vert	479.976	QP	34.8	18.1	11.0	32.0	-	31.9	46.0	14.1	
Vert	719.958	QP	30.5	20.8	12.4	31.9	-	31.8	46.0	14.2	
Vert	2483.500	PK	54.9	26.9	3.2	32.7	-	52.3	73.9	21.6	
Vert	4924.000	PK	47.9	30.8	5.3	31.7	-	52.3	73.9	21.6	
Vert	7386.000	PK	43.1	35.9	6.5	32.7	-	52.8	73.9	21.1	Floor Noise
Vert	9848.000	PK	43.6	38.8	7.1	33.5	-	56.0	73.9	17.9	Floor Noise
Vert	2483.500	AV	42.8	26.9	3.2	32.7	0.4	40.6	53.9	13.3	*1)
Vert	4924.000	AV	37.7	30.8	5.3	31.7	0.4	42.5	53.9	11.4	
Vert	7386.000	AV	34.2	35.9	6.5	32.7	-	43.9	53.9	10.0	Floor Noise
Vert	9848.000	AV	34.0	38.8	7.1	33.5	-	46.4	53.9	7.5	Floor Noise

Result = Reading + Ant Factor + Loss (Cable+Attenuator+Filter-Distance factor(above 10GHz)) - Gain(Amplifier) + Duty factor

\*Other frequency noises omitted in this report were not seen or had enough margin (more than 20dB).

\*The 10th harmonic was not seen so the result was its base noise level.

Distance factor: 10GHz-26.5GHz 20log(3.0m/1.0m)= 9.5dB

26.5GHz-40GHz 20log(3.0m/0.5m)=15.6dB

\*1) Not Out of Band emission (Leakage Power)

**UL Japan, Inc.**

**Ise EMC Lab.**

4383-326 Asama-cho, Ise-shi, Mie-ken 516-0021 JAPAN

Telephone : +81 596 24 8999

Facsimile : +81 596 24 8124

## Radiated Spurious Emission

Test place : Ise EMC Lab. No.3 Measurement Room  
Report No. : 10602907H  
Date : 12/13/2014  
Temperature/ Humidity : 23 deg. C / 39% RH  
Engineer : Takumi Shimada  
(1-10GHz)  
Mode : 11n-20 Tx 2412MHz

Polarity	Frequency [MHz]	Detector	Reading [dBuV]	Ant.Fac. [dB/m]	Loss [dB]	Gain [dB]	Duty Factor [dB]	Result [dBuV/m]	Limit [dBuV/m]	Margin [dB]	Remark
Hori	2390.000	PK	61.7	26.8	3.2	32.7	-	59.0	73.9	14.9	
Hori	2390.000	AV	43.0	26.8	3.2	32.7	0.2	40.5	53.9	13.4	*1)
Vert	2390.000	PK	60.6	26.8	3.2	32.7	-	57.9	73.9	16.0	
Vert	2390.000	AV	43.1	26.8	3.2	32.7	0.2	40.6	53.9	13.3	*1)

Result = Reading + Ant Factor + Loss (Cable+Attenuator+Filter-Distance factor(above 10GHz)) - Gain(Amplifier) + Duty factor

\*Other frequency noises omitted in this report were not seen or had enough margin (more than 20dB).

\*The 10th harmonic was not seen so the result was its base noise level.

Distance factor: 10GHz-26.5GHz 20log(3.0m/1.0m)= 9.5dB

\*1) Not Out of Band emission (Leakage Power)

### 20dBc Data Sheet

Polarity	Frequency [MHz]	Detector	Reading [dBuV]	Ant Factor [dB/m]	Loss [dB]	Gain [dB]	Result [dBuV/m]	Limit [dBuV/m]	Margin [dB]	Remark
Hori	2412.000	PK	92.5	26.8	3.2	32.7	89.8	-	-	Carrier
Hori	2400.000	PK	52.3	26.8	3.2	32.7	49.6	69.8	20.2	
Vert	2412.000	PK	91.2	26.8	3.2	32.7	88.5	-	-	Carrier
Vert	2400.000	PK	52.2	26.8	3.2	32.7	49.5	68.5	19.0	

Result = Reading + Ant Factor + Loss (Cable+Attenuator+Filter-Distance factor(above 10GHz)) - Gain(Amplifier)

**UL Japan, Inc.**

**Ise EMC Lab.**

4383-326 Asama-cho, Ise-shi, Mie-ken 516-0021 JAPAN

Telephone : +81 596 24 8999

Facsimile : +81 596 24 8124

## Radiated Spurious Emission

Test place : Ise EMC Lab. No.3 Measurement Room  
Report No. : 10602907H  
Date : 12/13/2014  
Temperature/ Humidity : 23 deg. C / 39% RH  
Engineer : Takumi Shimada  
(1-10GHz)  
Mode : 11n-20 Tx 2462MHz

Polarity	Frequency [MHz]	Detector	Reading [dBuV]	Ant.Fac. [dB/m]	Loss [dB]	Gain [dB]	Duty Factor [dB]	Result [dBuV/m]	Limit [dBuV/m]	Margin [dB]	Remark
Hori	2483.500	PK	59.5	26.9	3.2	32.7	-	56.9	73.9	17.0	
Hori	2483.500	AV	44.1	26.9	3.2	32.7	0.2	41.7	53.9	12.2	
Vert	2483.500	PK	57.2	26.9	3.2	32.7	-	54.6	73.9	19.3	
Vert	2483.500	AV	44.5	26.9	3.2	32.7	0.2	42.1	53.9	11.8	

Result = Reading + Ant Factor + Loss (Cable+Attenuator+Filter-Distance factor(above 10GHz)) - Gain(Amplifier) + Duty factor

\*Other frequency noises omitted in this report were not seen or had enough margin (more than 20dB).

\*The 10th harmonic was not seen so the result was its base noise level.

Distance factor: 10GHz-26.5GHz 20log(3.0m/1.0m)= 9.5dB

**UL Japan, Inc.**

**Ise EMC Lab.**

4383-326 Asama-cho, Ise-shi, Mie-ken 516-0021 JAPAN

Telephone : +81 596 24 8999

Facsimile : +81 596 24 8124

### Burst rate confirmation

Test place : Ise EMC Lab. No.3 Measurement Room  
Report No. : 10602907H  
Date : 12/13/2014  
Temperature/ Humidity : 23 deg. C / 39% RH  
Engineer : Takumi Shimada  
Mode : Tx 11b/11g

#### 11b 11Mbps

**Tx on / (Tx on + Tx off) = 0.988**  
**Tx on / (Tx on + Tx off) \* 100 = 98.8 %**

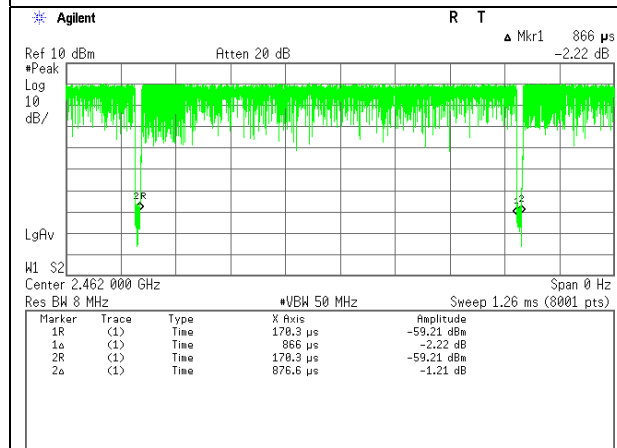

#### 11g 48Mbps

**Tx on / (Tx on + Tx off) = 0.907**  
**Tx on / (Tx on + Tx off) \* 100 = 90.7 %**  
**Duty factor = 10 \* log (0.2185 / 0.1981) 0.43 dB**

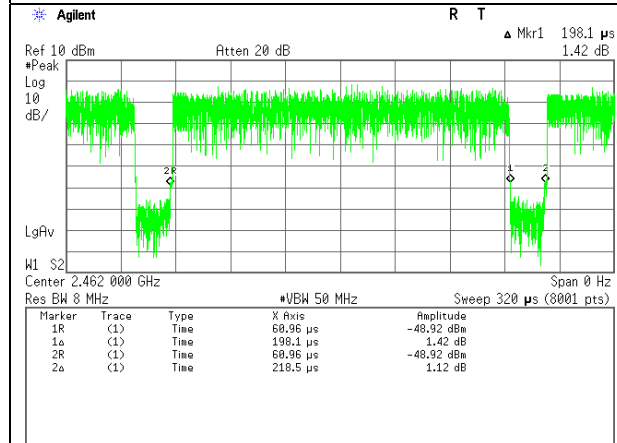

**UL Japan, Inc.**  
**Ise EMC Lab.**

4383-326 Asama-cho, Ise-shi, Mie-ken 516-0021 JAPAN

Telephone : +81 596 24 8999

Facsimile : +81 596 24 8124

### Burst rate confirmation

Test place	Ise EMC Lab. No.3 Measurement Room
Report No.	10602907H
Date	12/13/2014
Temperature/ Humidity	23 deg. C / 39% RH
Engineer	Takumi Shimada
Mode	Tx 11n-20

#### 11n-20 MCS3

<b>Tx on / (Tx on + Tx off) =</b>	<b>0.948</b>
<b>Tx on / (Tx on + Tx off) * 100 =</b>	<b>94.8 %</b>
<b>Duty factor = 10 * log (0.3864 / 0.3662)</b>	<b>0.23 dB</b>

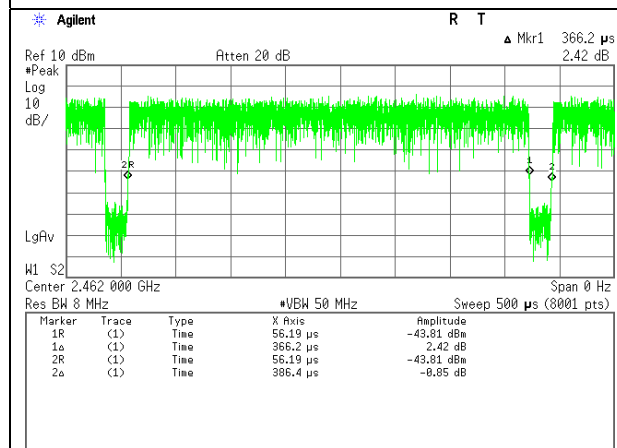

**UL Japan, Inc.**  
**Ise EMC Lab.**

4383-326 Asama-cho, Ise-shi, Mie-ken 516-0021 JAPAN

Telephone : +81 596 24 8999

Facsimile : +81 596 24 8124



**Conducted Spurious Emission**

Test place : Ise EMC Lab. No.11 Measurement Room  
Report No. : 10602907H  
Date : 12/11/2014  
Temperature/ Humidity : 24 deg. C / 29% RH  
Engineer : Takumi Shimada  
Mode : Tx 11g

**11g Tx 2462MHz**

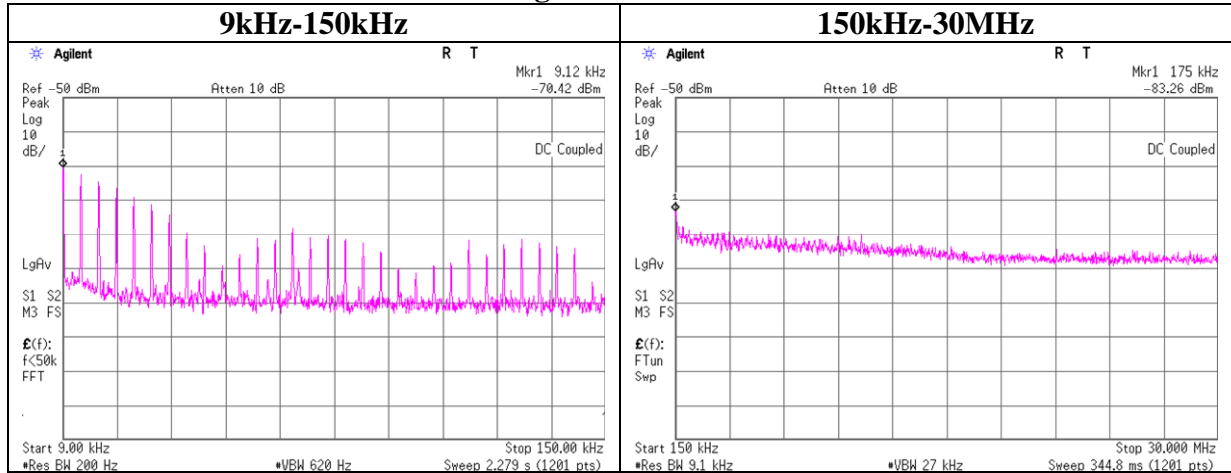

Frequency [kHz]	Reading [dBm]	Cable Loss [dB]	Attenuator [dB]	Antenna Gain [dBi]	EIRP [dBm]	Distance [m]	Ground bounce [dB]	E (field strength) [dBuV/m]	Limit [dBuV/m]
9.12	-70.4	0.50	9.8	2.0	-58.1	300	6.0	3.2	68.4
175.00	-83.3	0.50	9.8	2.0	-70.9	300	6.0	-9.7	42.7

$E = \text{EIRP} - 20\log(D) + \text{Ground bounce} + 104.8 [\text{dBuV/m}]$

$\text{EIRP} = \text{Reading} + \text{Cable Loss} + \text{Attenuator} + \text{Antenna Gain} + 10 * \log(N)$

**UL Japan, Inc.**

**Ise EMC Lab.**

4383-326 Asama-cho, Ise-shi, Mie-ken 516-0021 JAPAN

Telephone : +81 596 24 8999

Facsimile : +81 596 24 8124

## Power Density

Test place : Ise EMC Lab. No.11 Measurement Room  
Report No. : 10602907H  
Date : 12/11/2014  
Temperature/ Humidity : 24 deg. C / 29% RH  
Engineer : Takumi Shimada  
Mode : Tx 11b/11g

11b

Freq.	Reading	Cable Loss	Atten.	Result	Limit	Margin
[MHz]	[dBm]	[dB]	[dB]	[dBm]	[dBm]	[dB]
2412.00	-17.70	1.78	10.00	-5.92	8.00	13.92
2437.00	-16.94	1.79	10.00	-5.15	8.00	13.15
2462.00	-16.50	1.80	10.00	-4.70	8.00	12.70

11g

Freq.	Reading	Cable Loss	Atten.	Result	Limit	Margin
[MHz]	[dBm]	[dB]	[dB]	[dBm]	[dBm]	[dB]
2412.00	-24.46	1.78	10.00	-12.68	8.00	20.68
2437.00	-23.34	1.79	10.00	-11.55	8.00	19.55
2462.00	-24.22	1.80	10.00	-12.42	8.00	20.42

Sample Calculation:

Result = Reading + Cable Loss (including the cable(s) customer supplied) + Attenuator

---

**UL Japan, Inc.**

**Ise EMC Lab.**

4383-326 Asama-cho, Ise-shi, Mie-ken 516-0021 JAPAN

Telephone : +81 596 24 8999

Facsimile : +81 596 24 8124

**Power Density**

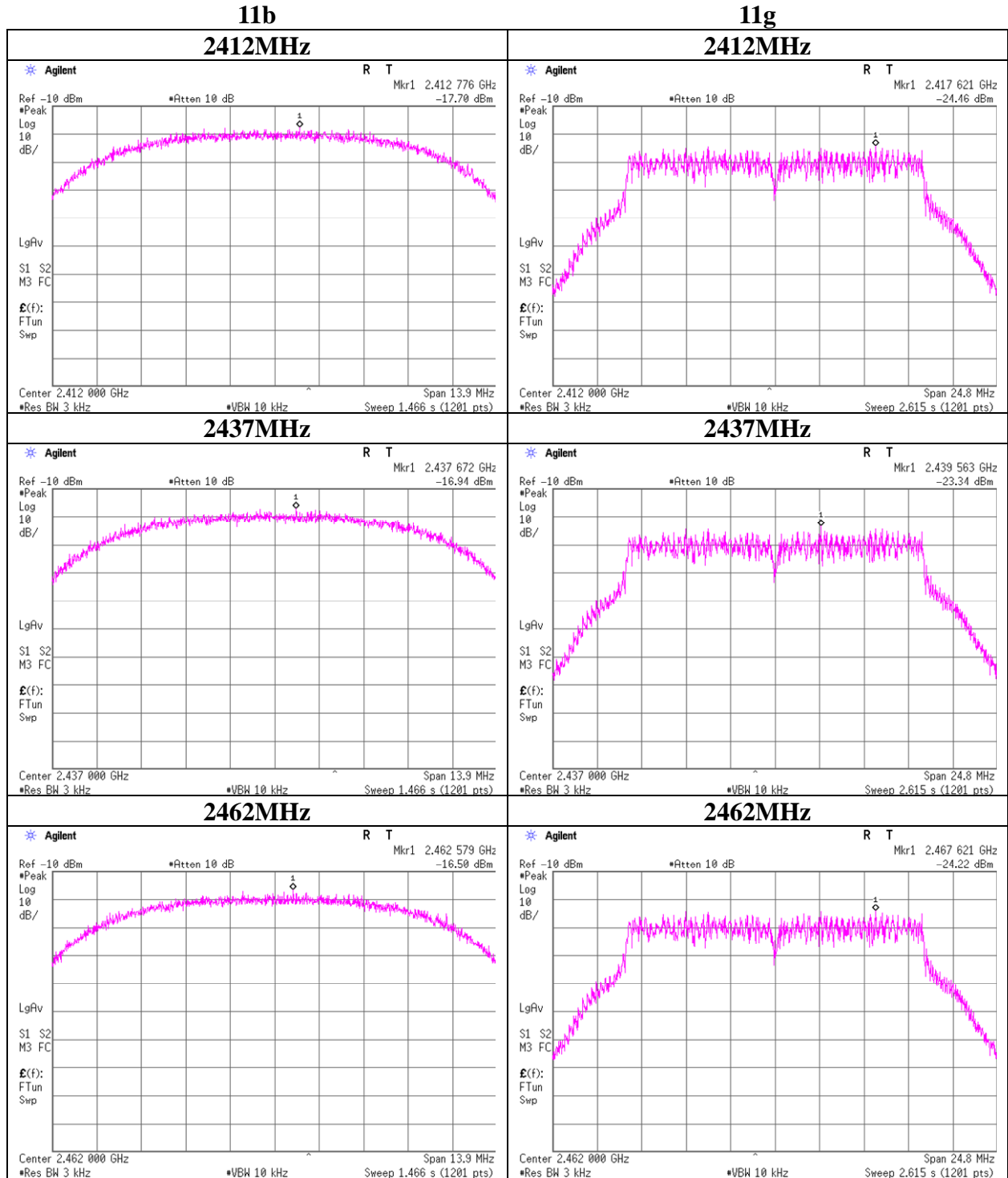

### Power Density

Test place Ise EMC Lab. No.11 Measurement Room  
Report No. 10602907H  
Date 12/11/2014  
Temperature/ Humidity 24 deg. C / 29% RH  
Engineer Takumi Shimada  
Mode 11n-20 Tx

Freq. [MHz]	Reading [dBm]	Cable Loss [dB]	Atten. [dB]	Result		Limit [dBm]	Margin [dB]
				[dBm]	[mW]		
2412.00	-25.08	1.78	10.00	-13.30	0.05	8.00	21.30
2437.00	-24.58	1.79	10.00	-12.79	0.05	8.00	20.79
2462.00	-24.18	1.80	10.00	-12.38	0.06	8.00	20.38

Sample Calculation:

Result = Reading + Cable Loss (including the cable(s) customer supplied) + Attenuator

---

**UL Japan, Inc.**

**Ise EMC Lab.**

4383-326 Asama-cho, Ise-shi, Mie-ken 516-0021 JAPAN

Telephone : +81 596 24 8999

Facsimile : +81 596 24 8124

## Power Density

11n-20

2412MHz

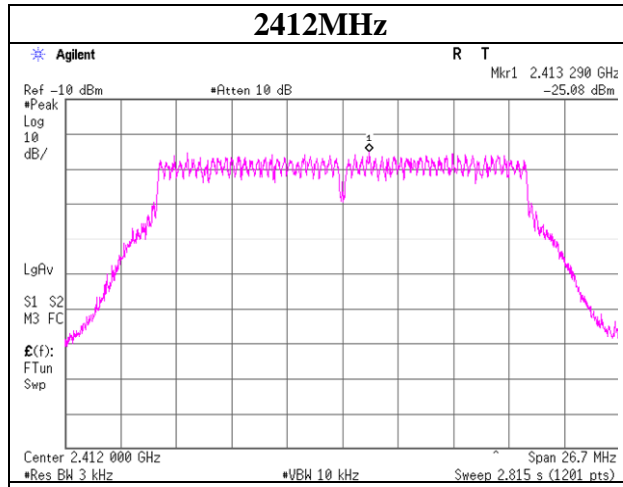

2437MHz

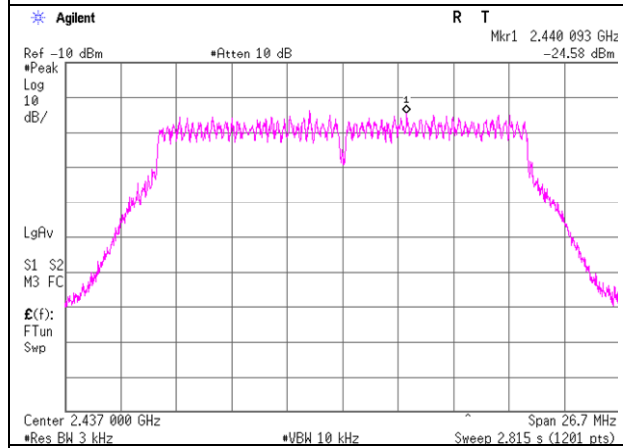

2462MHz

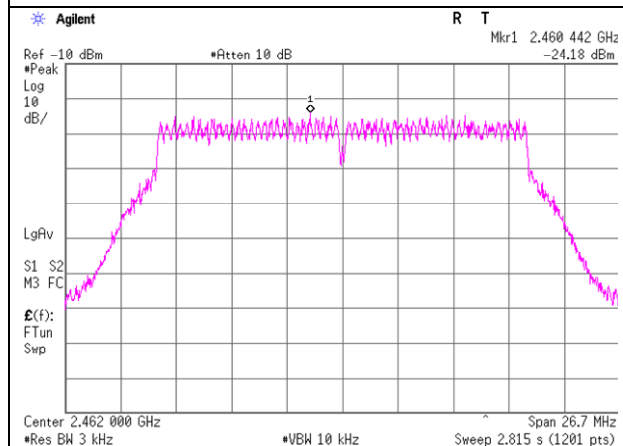

**UL Japan, Inc.**  
**Ise EMC Lab.**

4383-326 Asama-cho, Ise-shi, Mie-ken 516-0021 JAPAN

Telephone : +81 596 24 8999

Facsimile : +81 596 24 8124

### 99%Occupied Bandwidth

Test place	Ise EMC Lab. No.11 Measurement Room
Report No.	10602907H
Date	12/11/2014
Temperature/ Humidity	24 deg. C / 29% RH
Engineer	Takumi Shimada
Mode	Tx 11b/11g

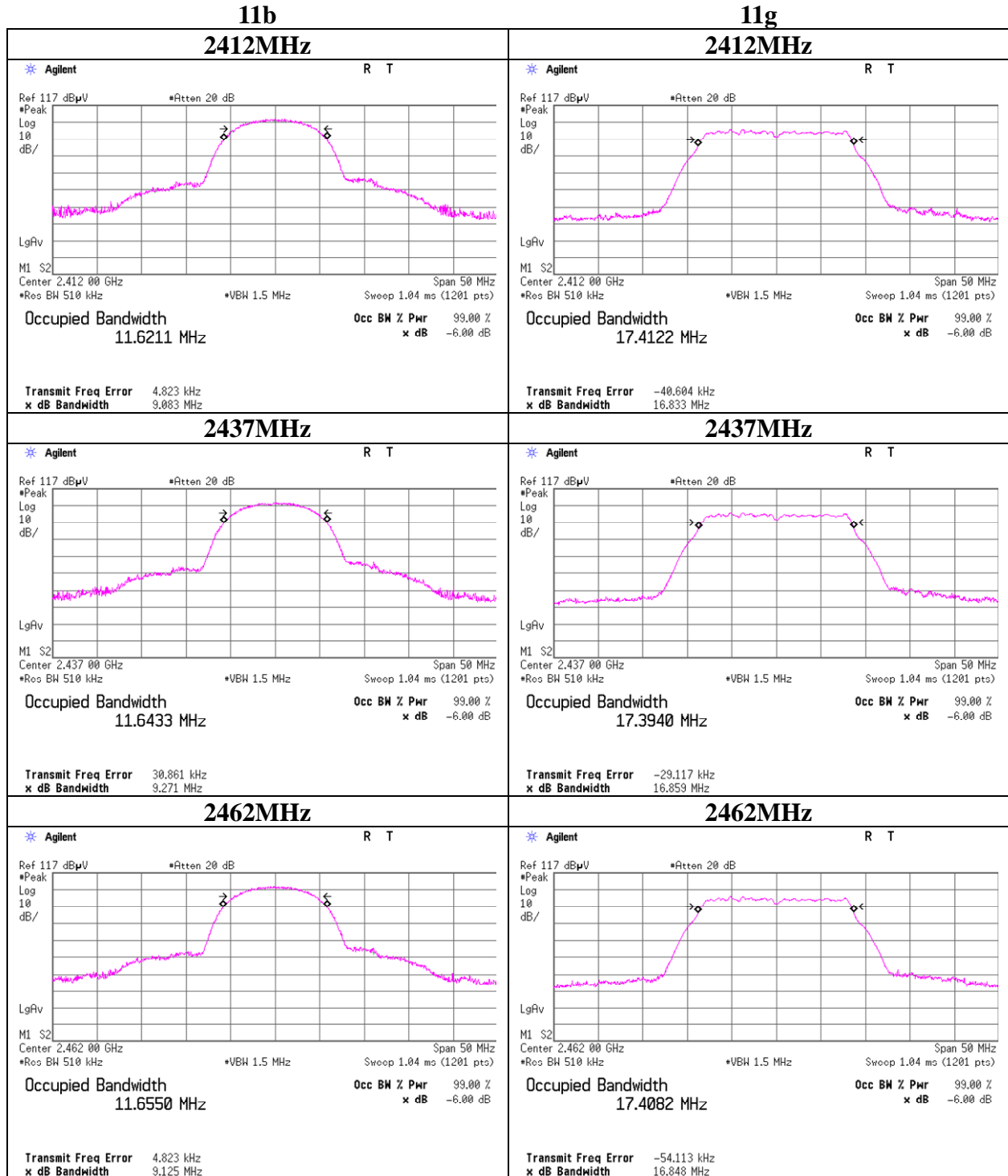

## 99% Occupied Bandwidth

Test place	Ise EMC Lab. No.11 Measurement Room
Report No.	10602907H
Date	12/11/2014
Temperature/ Humidity	24 deg. C / 29% RH
Engineer	Takumi Shimada
Mode	Tx 11n-20

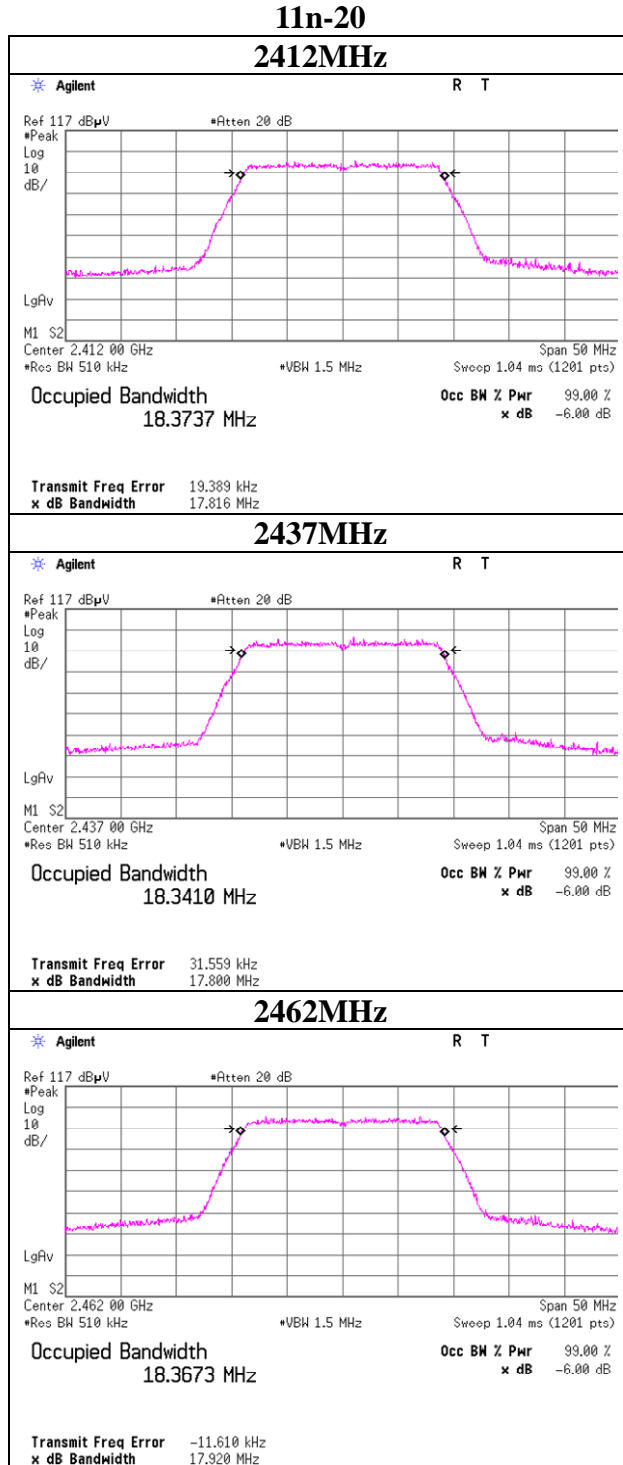

## APPENDIX 2: Test instruments

### EMI test equipment

Control No.	Instrument	Manufacturer	Model No	Serial No	Test Item	Calibration Date * Interval(month)
MOS-12	Thermo-Hygrometer	Custom	CTH-180	1201	AT	2014/01/14 * 12
MPM-08	Power Meter	Anritsu	ML2495A	6K00003338	AT	2014/10/16 * 12
MPSE-11	Power sensor	Anritsu	MA2411B	011737	AT	2014/10/15 * 12
MCC-137	Microwave cable	HUBER+SUHNER	SUCOFLEX 102	37954/2	AT	2014/10/02 * 12
MAT-25	Attenuator(10dB)(above 1GHz)	Agilent	8493C	71642	AT	2014/06/12 * 12
MOS-19	Thermo-Hygrometer	Custom	CTH-201	0001	AT	2013/12/17 * 12
MSA-14	Spectrum Analyzer	Agilent	E4440A	MY48250080	AT	2014/10/17 * 12
MAT-22	Attenuator(10dB) 1-18GHz	Orient Microwave	BX10-0476-00	-	AT	2014/03/13 * 12
MCC-38	Coaxial Cable	UL Japan	-	-	AT	2014/12/02 * 12
MAT-10	Attenuator(10dB)	Weinschel Corp	2	BL1173	AT	2014/11/19 * 12
MAEC-03	Semi Anechoic Chamber(NSA)	TDK	Semi Anechoic Chamber 3m	DA-10005	RE	2014/02/27 * 12
MOS-13	Thermo-Hygrometer	Custom	CTH-180	1301	RE	2014/02/20 * 12
MJM-16	Measure	KOMELON	KMC-36	-	RE	-
COTS-MEMI	EMI measurement program	TSJ	TEPTO-DV	-	RE	-
MSA-03	Spectrum Analyzer	Agilent	E4448A	MY44020357	RE	2014/04/08 * 12
MHA-20	Horn Antenna 1-18GHz	Schwarzbeck	BBHA9120D	258	RE	2014/05/26 * 12
MCC-167	Microwave Cable	Junkosha	MWX221	1404S374(1m) / 1405S074(5m)	RE	2014/05/26 * 12
MPA-11	MicroWave System Amplifier	Agilent	83017A	MY39500779	RE	2014/03/24 * 12
MHF-25	High Pass Filter 3.5-18.0GHz	UL Japan	HPF SELECTOR	001	RE	2014/09/22 * 12
MHA-16	Horn Antenna 15-40GHz	Schwarzbeck	BBHA9170	BBHA9170306	RE	2014/05/26 * 12
MTR-08	Test Receiver	Rohde & Schwarz	ESCI	100767	RE	2014/08/19 * 12
MBA-03	Biconical Antenna	Schwarzbeck	BBA9106	1915	RE	2014/10/18 * 12
MLA-03	Logperiodic Antenna	Schwarzbeck	USLP9143	174	RE	2014/10/18 * 12
MCC-51	Coaxial cable	UL Japan	-	-	RE	2014/07/14 * 12
MAT-70	Attenuator(6dB)	Agilent	8491A-006	MY52460153	RE	2014/04/14 * 12
MPA-13	Pre Amplifier	SONOMA INSTRUMENT	310	260834	RE	2014/03/14 * 12
MAEC-02	Semi Anechoic Chamber(NSA)	TDK	Semi Anechoic Chamber 3m	DA-06902	CE	2014/06/25 * 12
MOS-22	Thermo-Hygrometer	Custom	CTH-201	0003	CE	2014/02/20 * 12
MJM-14	Measure	KOMELON	KMC-36	-	CE	-
MSA-10	Spectrum Analyzer	Agilent	E4448A	MY46180655	CE	2014/02/20 * 12
MTR-03	Test Receiver	Rohde & Schwarz	ESCI	100300	CE	2014/06/03 * 12
MLS-23	LISN(AMN)	Schwarzbeck	NSLK8127	8127-729	CE(AE)	2014/07/10 * 12
MLS-24	LISN(AMN)	Schwarzbeck	NSLK8127	8127-730	CE(EUT)	2014/07/10 * 12
MTA-28	Terminator	TME	CT-01	-	CE	2014/11/26 * 12
MCC-13	Coaxial Cable	Fujikura	3D-2W(12m)/5D-2W(5m)/5D-2W(0.8m)/5D-2W(1m)	-	CE	2014/02/20 * 12
MAT-65	Attenuator(13dB)	JFW Industries, Inc.	50FP-013H2 N	-	CE	2014/01/29 * 12

The expiration date of the calibration is the end of the expired month.

All equipment is calibrated with valid calibrations. Each measurement data is traceable to the national or international standards.

As for some calibrations performed after the tested dates, those test equipment have been controlled by means of an unbroken chains of calibrations.

Test Item: CE: Conducted Emission test  
RE: Radiated Emission test  
AT: Antenna Terminal Conducted test

### UL Japan, Inc. Ise EMC Lab.

4383-326 Asama-cho, Ise-shi, Mie-ken 516-0021 JAPAN  
Telephone : +81 596 24 8999  
Facsimile : +81 596 24 8124