

FCC PART 15C TEST REPORT FOR CERTIFICATION

On Behalf of

NVIDIA Corporation

SHIELD Remote

Model No. : P2930

FCC ID: VOB-P2930

Prepared for : NVIDIA Corporation
2701 San Tomas Expressway, Santa Clara, CA, 95050,
USA

Prepared By : Audix Technology (Shenzhen) Co., Ltd.
No. 6, Ke Feng Rd., 52 Block,
Shenzhen Science & Industrial Park,
Nantou, Shenzhen, Guangdong, China

Tel: (0755) 26639496

Report Number : ACS-F16100
Date of Test : May.06~23, 2016
Date of Report : Aug.22, 2016

TABLE OF CONTENTS

<u>Description</u>	<u>Page</u>
1. SUMMARY OF STANDARDS AND RESULTS	1-1
1.1. Description of Standards and Results	1-1
2. GENERAL INFORMATION	2-1
2.1. Description of Device (EUT)	2-1
2.2. Tested Supporting System Details	2-2
2.3. Block Diagram of connection between EUT and simulators	2-2
2.4. Test information	2-2
2.5. Test Facility	2-3
2.6. Measurement Uncertainty (95% confidence levels, k=2)	2-3
3. POWER LINE CONDUCTED EMISSION TEST	3-1
4. RADIATED EMISSION MEASUREMENT	4-1
4.1. Test Equipment	4-1
4.2. Block Diagram of Test Setup	4-2
4.3. Radiated Emission Limit Standard:	4-3
4.4. EUT Configuration on Test	4-3
4.5. Operating Condition of EUT	4-3
4.6. Test Procedure	4-3
4.7. Radiated Emission Test Results	4-4
5. CONDUCTED SPURIOUS EMISSIONS	5-1
5.1. Test Equipment	5-1
5.2. Limit	5-1
5.3. Test Procedure	5-1
5.4. Test result	5-1
6. 6dB BANDWIDTH TEST	6-1
6.1. Test Equipment	6-1
6.2. Limit	6-1
6.3. Test Procedure	6-1
6.4. Test Results	6-1
7. MAXIMUM PEAK OUTPUT POWER TEST	7-1
7.1. Test Equipment	7-1
7.2. Limit	7-1
7.3. Test Procedure	7-1
7.4. Test Results	7-1
8. BAND EDGE COMPLIANCE TEST	8-1
8.1. Test Equipment	8-1
8.2. Limit	8-1
8.3. Test Produce	8-1
8.4. Test Results	8-1
9. POWER SPECTRAL DENSITY TEST	9-1
9.1. Test Equipment	9-1
9.2. Limit	9-1
9.3. Test Procedure	9-1
9.4. Test Results	9-1
10. ANTENNA REQUIREMENT	10-1
10.1. STANDARD APPLICABLE	10-1

	10.2. ANTENNA CONNECTED CONSTRUCTION	10-1
11.	DEVIATION TO TEST SPECIFICATIONS.....	11-1
12.	HOTOGRAPH OF TEST	12-1
	12.1. Photos of Radiated Emission Test.....	12-1
13.	PHOTOGRAPH OF EUT.....	13-1

TEST REPORT CERTIFICATION

Applicant : NVIDIA Corporation
Manufacturer : NVIDIA Corporation
Product : SHIELD Remote
FCC ID : VOB-P2930
(A) Model No. : P2930
(B) Power Supply : DC 3V
(C) Test Voltage : DC 3V

Tested for comply with:

FCC Rules and Regulations Part 15 Subpart C: 2014
Test procedure used: KDB558074 D01 v03r05

The device described above is tested by AUDIX TECHNOLOGY (SHENZHEN) CO., LTD. to confirm comply with all the FCC Part 15 Subpart C requirements. The test results are contained in this test report and AUDIX TECHNOLOGY (SHENZHEN) CO., LTD. is assumed full responsibility for the accuracy and completeness of these tests. Also, this report shows that the Equipment Under Test (EUT) is to be technically compliant with the FCC requirements. This report contains data that are not covered by the NVLAP accreditation.

This Report is made under FCC Part 2.1075. No modifications were required during testing to bring this product into compliance.

This report applies to above tested sample only. This report shall not be reproduced in part without written approval of AUDIX TECHNOLOGY (SHENZHEN) CO., LTD.

The report must not be used by the client to claim product certification, approval, or endorsement by NVLAP, NIST, or any agency of the federal government.

Date of Test : May.06~23, 2016 Report of date: Aug.22, 2016

Prepared by : Cindy Zhu Reviewed by : Sunny Lu
Cindy Zhu / Assistant Sunny Lu / Deputy Manager

信華科技(深圳)有限公司
Audix Technology (Shenzhen) Co., Ltd.
EMC 部門報告專用章
Stamp only for EMC Dept. Report
Signature: David Jin

Approved & Authorized Signer :

David Jin / Manager

1. SUMMARY OF STANDARDS AND RESULTS

1.1. Description of Standards and Results

The EUT have been tested according to the applicable standards as referenced below.

EMISSION		
Description of Test Item	Standard	Results
Power Line Conducted Emission Test	FCC Part 15: 15.207 KDB558074 D01 v03r05	N/A
Radiated Emission Test	FCC Part 15: 15.209 FCC Part 15: 15.247(d) KDB558074 D01 v03r05	PASS
Conducted Spurious Emissions	FCC Part 15: 15.247(a)(1) KDB558074 D01 v03r05	PASS
Carrier Frequency Separation Test	FCC Part 15: 15.247(a)(1) KDB558074 D01 v03r05	PASS
6dB Bandwidth Test	FCC Part 15: 15.215 KDB558074 D01 v03r02	PASS
Maximum Peak Output Power Test	FCC Part 15: 15.247(b)(1) KDB558074 D01 v03r05	PASS
Band Edge Compliance Test	FCC Part 15: 15.247(d) KDB558074 D01 v03r05	PASS
Power Spectral Density Test	FCC Part 15: 15.247(d) KDB558074 D01 v03r05	PASS

2. GENERAL INFORMATION

2.1. Description of Device (EUT)

Product	: SHIELD Remote
Model No.	: P2930
FCC ID	: VOB-P2930
Radio	: Bluetooth V4.1
Operation Frequency	: 2402-2480MHz
Modulation Technology	: GFSK
Antenna Assembly Gain	: Monopole Antenna; -1.8dBi
Applicant	: NVIDIA Corporation 2701 San Tomas Expressway, Santa Clara, CA,95050,USA
Manufacturer	: NVIDIA Corporation 2701 San Tomas Expressway, Santa Clara, CA,95050,USA
Date of Test	: May.06~23, 2016
Date of Receipt	: May.04, 2016

2.2. Tested Supporting System Details

No.	Description	ACS No.	Manufacturer	Model	Serial Number
1.	Notebook	N/A	DELL	PP09S	N/A
		Power Cord: Unshielded, Detachable, 1.8m Power Adapter: Manufacturer: DELL, M/N: LA65NS1-00 Cable: Unshielded, Detachable, 4.0m(Bond one ferrite core)			
2.	USB Cable#1	Unshielded, Detachable, 1.17m			
3.	USB Cable#2	Unshielded, Detachable, 1.53m			

2.3. Block Diagram of connection between EUT and simulators

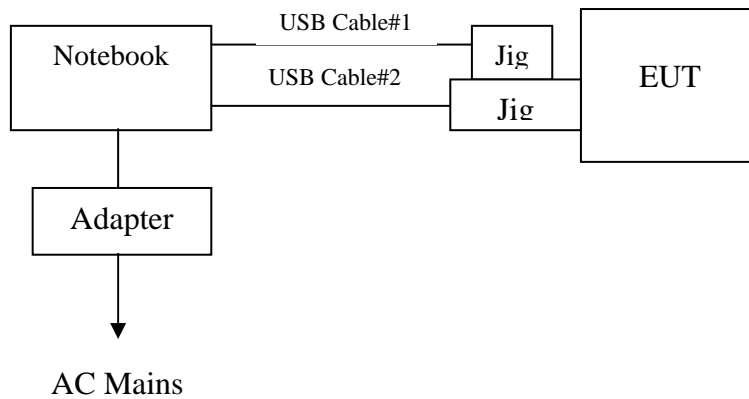

(EUT: SHIELD Remote)

2.4. Test information

A Special Test Software was used to control EUT work in Continuous TX mode, and select test channel.

Tested mode, channel, and data rate information			
Mode	data rate (Mbps)	Channel	Frequency (MHz)
Tx Mode GFSK modulation	1	Low :CH 0	2402
	1	Middle: CH19	2440
	1	High: CH39	2480

2.5. Test Facility
Site Description

Name of Firm	:	Audix Technology (Shenzhen) Co., Ltd. No. 6, Ke Feng Rd., 52 Block, Shenzhen Science & Industrial Park, Nantou, Shenzhen, Guangdong, China
3m Anechoic Chamber	:	Certificated by FCC, USA Registration Number: 90454 Valid Date: Dec.30,2017
3m & 10m Anechoic Chamber	:	Certificated by FCC, USA Registration Number: 794232 Valid Date: Jul.12, 2017
EMC Lab.	:	Certificated by Industry Canada Registration Number: IC 5183A-1 Valid Date: May.14, 2017
	:	Certificated by DAkkS, Germany Registration No: D-PL-12151-01-00 Valid Date: Dec.15, 2016
	:	Accredited by NVLAP, USA NVLAP Code: 200372-0 Valid Date: Mar.31, 2017

2.6. Measurement Uncertainty (95% confidence levels, k=2)

Test Item	Uncertainty
Uncertainty for Radiation Emission test in 3m chamber	3.0 dB(30~200MHz, Polarization: H)
	3.0 dB(30~200MHz, Polarization: V)
	3.2 dB(200M~1GHz, Polarization: H)
	3.1 dB(200M~1GHz, Polarization: V)
Uncertainty for Radiation Emission test in 3m chamber (1GHz-18GHz)	6.3 dB (1~6GHz, Distance: 3m)
	5.7 dB (6~18GHz, Distance: 3m)
Uncertainty for Radiated Spurious Emission test in RF chamber	3.6 dB
Uncertainty for Conduction Spurious emission test	2.0 dB
Uncertainty for Output power test	0.8 dB
Uncertainty for Bandwidth test	83 kHz
Uncertainty for DC power test	0.1 %
Uncertainty for test site temperature and humidity	0.6
	3%

3. POWER LINE CONDUCTED EMISSION TEST

According to Paragraph (c) of FCC Part 15 section 15.247, Tests to demonstrate compliance with the conducted limits are not required for devices which only employ battery power for operation and which do not operate from the AC power lines or contain provisions for operation while connected to the AC power lines.

4. RADIATED EMISSION MEASUREMENT

4.1. Test Equipment

Frequency rang: 30~1000MHz

Item	Equipment	Manufacturer	Model No.	Serial No.	Last Cal.	Cal. Interval
1.	3#Chamber	AUDIX	N/A	N/A	Mar.28,16	1 Year
2.	EMI Spectrum	Agilent	E4407B	MY41440292	Apr.24,16	1 Year
3.	Test Receiver	Rohde & Schwarz	ESVS10	834468/011	Apr.24,16	1 Year
4.	Amplifier	HP	8447D	2648A04738	Apr.24,16	1 Year
5.	Bi-log Antenna	TESEQ	CBL6112D	35375	Jun.30,15	1 Year
6.	RF Cable	MIYAZAKI	CFD400-N W(3.5M)	No.3	Apr.24,16	1 Year
7.	RF Cable	MIYAZAKI	CFD400-L W(22M)	No.7	Apr.24,16	1 Year
8.	Coaxial Switch	Anritsu	MP59B	6201397222	Apr.23,16	1 Year
9.	Test Software	AUDIX	e3	6.2009-5-21a(n)	N/A	N/A

Note: N/A means Not applicable.

Frequency rang: above 1000MHz

Item	Equipment	Manufacturer	Model No.	Serial No.	Last Cal.	Cal. Interval
1.	Spectrum Analyzer	Agilent	E4446A	US44300459	Apr.24,16	1 Year
2.	Horn Antenna	ETS	3115	9510-4877	Oct.15,15	1 Year
3.	Amplifier	Agilent	8449B	3008A02495	Apr.24,16	1 Year
4.	RF Cable	Hubersuhner	SUCOFLEX104	274094/4	Apr.24,16	1 Year
5.	Horn Antenna	ETS	3116	00060089	Oct.15,15	1 Year
6.	Test Software	AUDIX	e3	6.2009-5-21a(n)	N/A	N/A

Note: N/A means Not applicable.

4.2. Block Diagram of Test Setup
For frequency range 30MHz-1000MHz

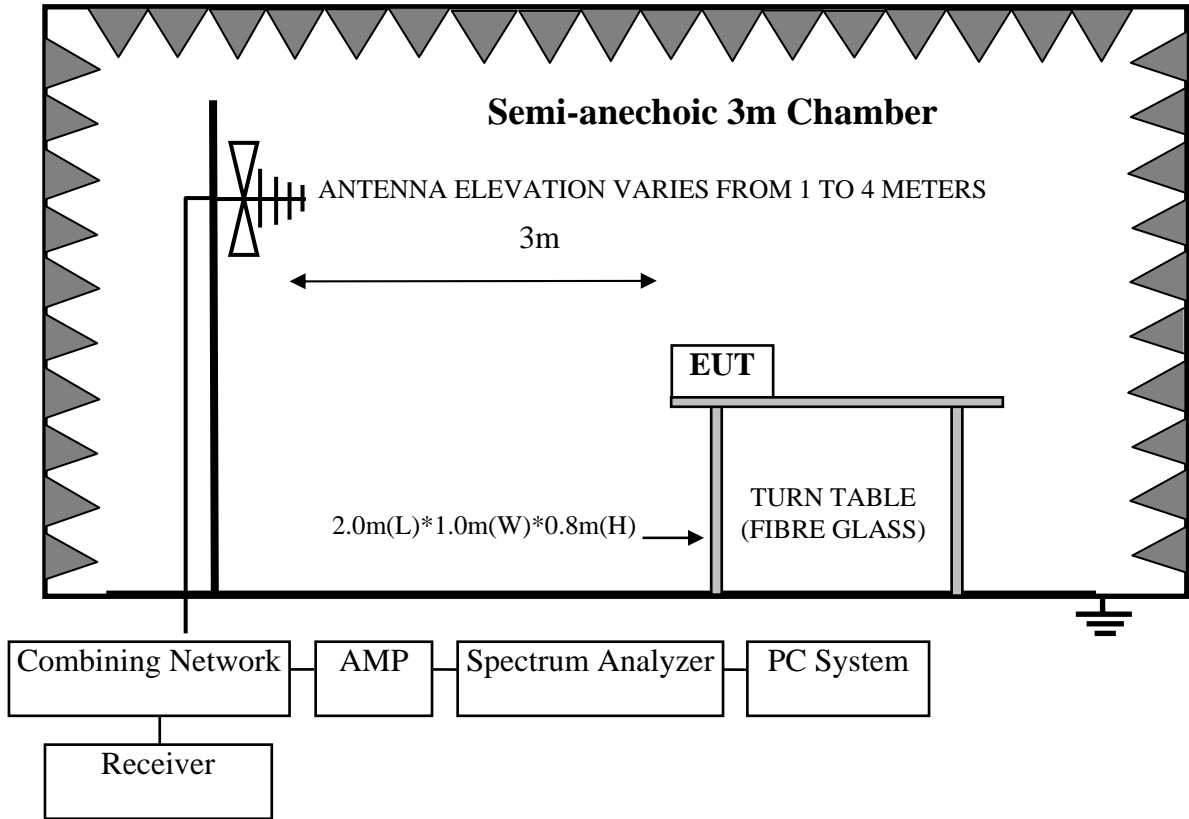

For frequency range 1GHz-25GHz

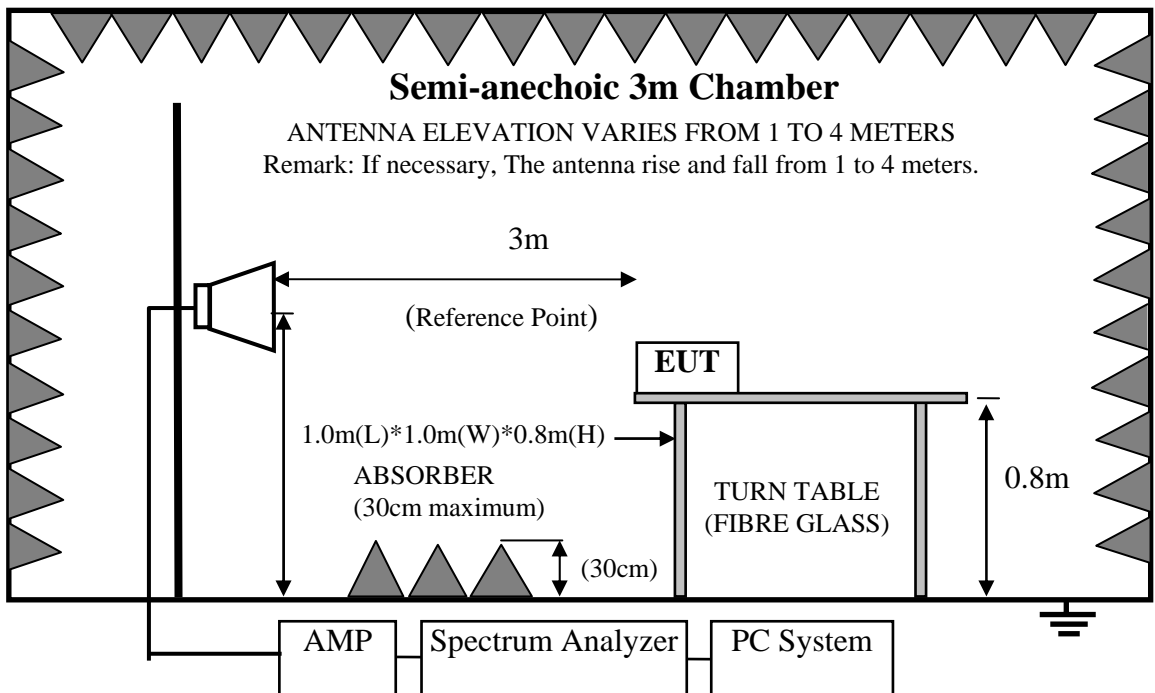

4.3. Radiated Emission Limit Standard:

FREQUENCY MHz	DISTANCE Meters	FIELD STRENGTHS LIMIT	
		μV/m	dB(μV)/m
30 ~ 88	3	100	40.0
88 ~ 216	3	150	43.5
216 ~ 960	3	200	46.0
960 ~ 1000	3	500	54.0
Above 1000MHz	3	74.0 dB(μV)/m (Peak) 54.0 dB(μV)/m (Average)	

- Remark :
- (1) Emission level $dB\mu V = 20 \log$ Emission level $\mu V/m$
 - (2) The smaller limit shall apply at the cross point between two frequency bands.
 - (3) Distance is the distance in meters between the measuring instrument, antenna and the closest point of any part of the device or system.
 - (4) The emission limits shown in the above table are based on measurements employing a CISPR quasi-peak detector except for the frequency bands 9-90 kHz, 110-490 kHz and above 1000 MHz. Radiated emission limits in these three bands are based on measurements employing an average detector.

4.4. EUT Configuration on Test

The following equipment are installed on Radiated Emission Test to meet the commission requirements and operating regulations in a manner which tends to maximize its emission characteristics in normal application.

4.4.1. SHIELD Remote (EUT)

Model Number : P2930
Serial Number : N/A

4.5. Operating Condition of EUT

- 4.5.1. Setup the EUT and simulator as shown as Section 3.2.
- 4.5.2. Turn on the power of all equipments.
- 4.5.3. Let EUT work in Tx mode.

4.6. Test Procedure

The EUT and its simulators are placed on a turn table, which is 0.8 meter high above ground. The turn table can rotate 360 degrees to determine the position of the maximum emission level. The EUT is set 3 meters away from the receiving antenna, which is mounted on a antenna tower. The antenna can be moved up and down between 1 meter and 4 meters to find out the maximum emission level. Broadband antenna (calibrated bilog antenna) is used as receiving antenna. Both horizontal and vertical polarization of the antenna is set on Test. In order to find the maximum emission levels, all of the interface cables must be manipulated according to ANSI C63.10-2013 on radiated emission Test.

This test was performed with EUT in X, Y, Z position, and the worse case was found when EUT in X position as the test photo indicated.

The bandwidth of the EMI test receiver (R&S ESVS10) is set at 120kHz for frequency range from 30MHz to 1000 MHz.

The bandwidth of the Spectrum's RBW is set at 1MHz and VBW is set at 3MHz for peak emissions measurement above 1GHz.

This device is pulse Modulated, a duty cycle factor was used to calculated average level based measured peak level.

The frequency range from 30MHz to 10th harmonic (25GHz) are checked. and no any emissions were found from 18GHz to 25 GHz, So the radiated emissions from 18GHz to 25GHz were not record.

4.7. Radiated Emission Test Results **PASS.**

All the emissions from 30MHz to 25GHz were comply with the 15.209 Limit.

Note: The duty cycle factor for calculate average level is 1.593dB, and average limit is 20dB below peak limit, so if peak measured level comply with average limit, the average level was deemed to comply with average limit

$$\text{Duty cycle factor} = 10\log (1/\text{duty cycle}) = 1.593\text{dB}$$

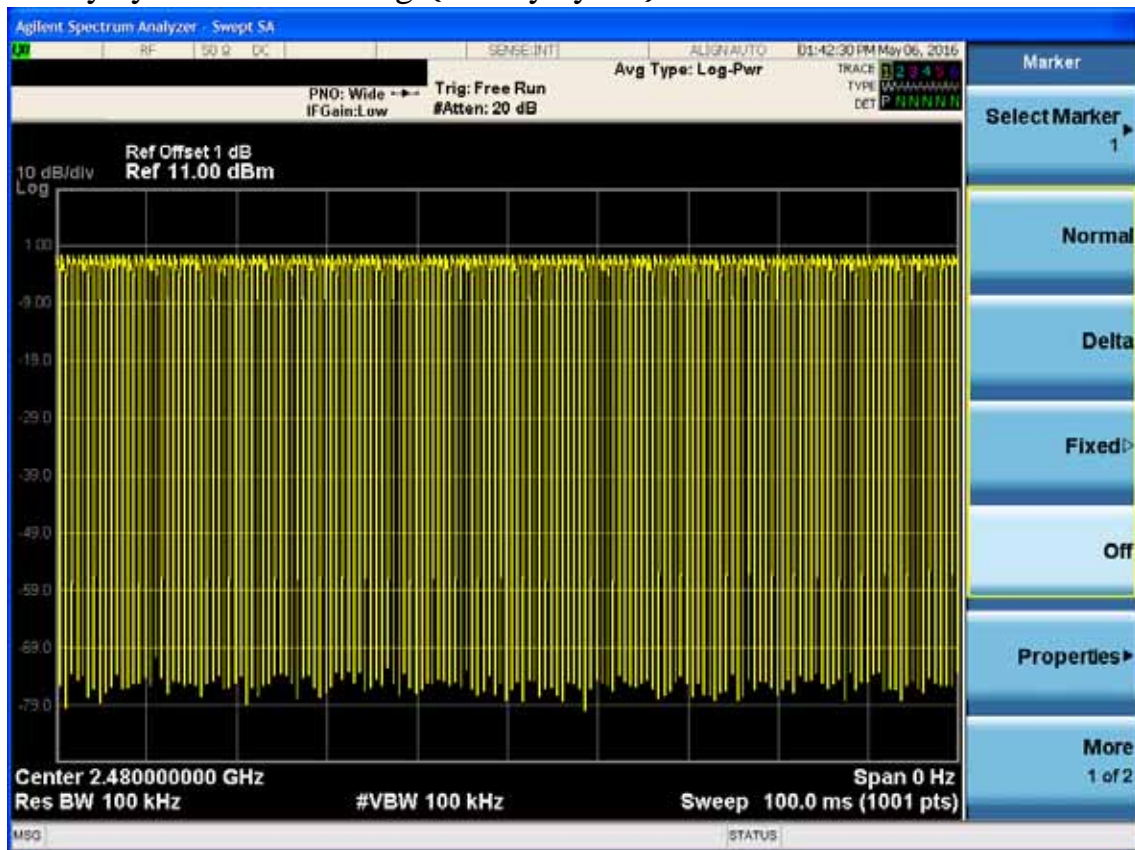

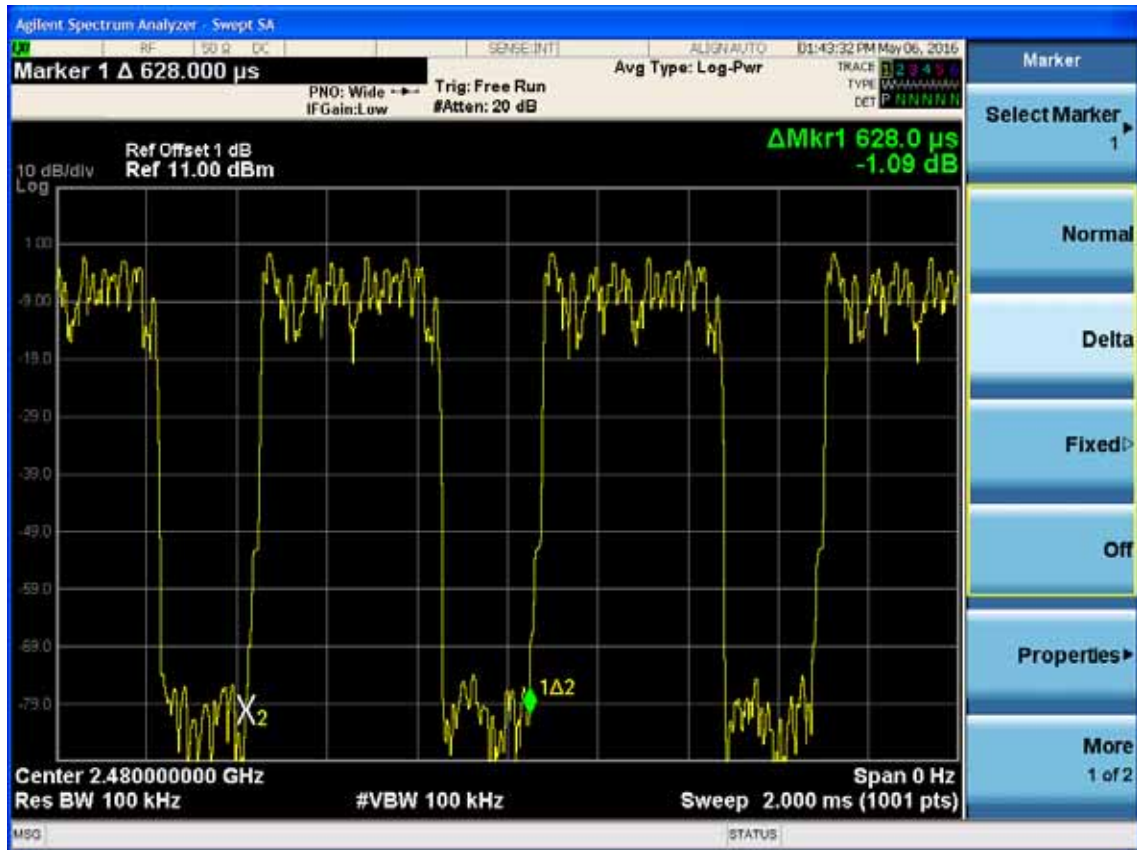

Frequency: 30MHz~1GHz

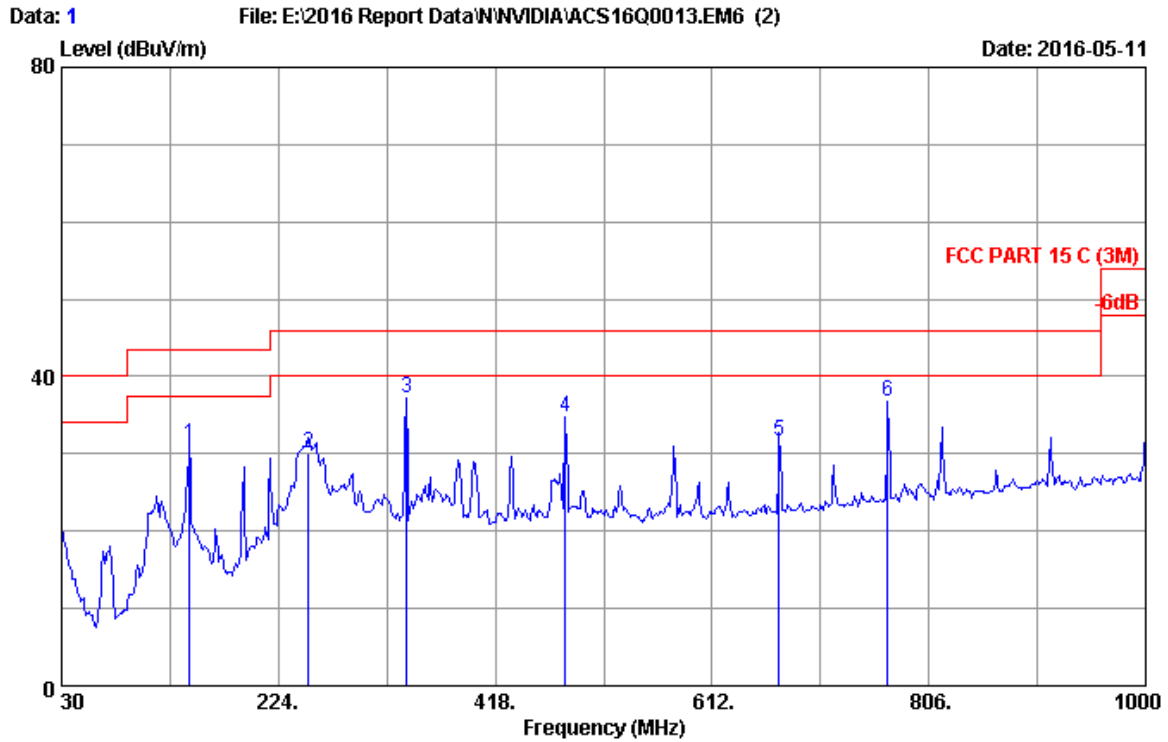

Site no. : 3m Chamber Data no. : 1
 Dis. / Ant. : 3m 2015 CBL6112D 35375 Ant. pol. : HORIZONTAL
 Limit : FCC PART 15 C (3M)
 Env. / Ins. : 24°C/51% Engineer : Leo_Li
 EUT : SHIELD Remote
 Power rating : DC 3V
 Test Mode : Tx Mode
 M/N:P2930

No.	Freq. (MHz)	Ant. Factor (dB/m)	Cable Loss (dB)	Reading (dBUV)	Emission Level (dBUV/m)	Limits (dBUV/m)	Margin (dB)	Remark
1	144.460	11.89	1.29	18.06	31.24	43.50	12.26	QP
2	251.160	13.57	1.71	14.76	30.04	46.00	15.96	QP
3	338.460	15.25	2.01	20.05	37.31	46.00	8.69	QP
4	481.050	18.11	2.47	14.18	34.76	46.00	11.24	QP
5	672.140	19.87	2.95	8.86	31.68	46.00	14.32	QP
6	769.140	20.79	3.19	12.75	36.73	46.00	9.27	QP

Remarks: 1. Emission Level= Antenna Factor + Cable Loss + Reading.
 2. The emission levels that are 20dB below the official limit are not reported.

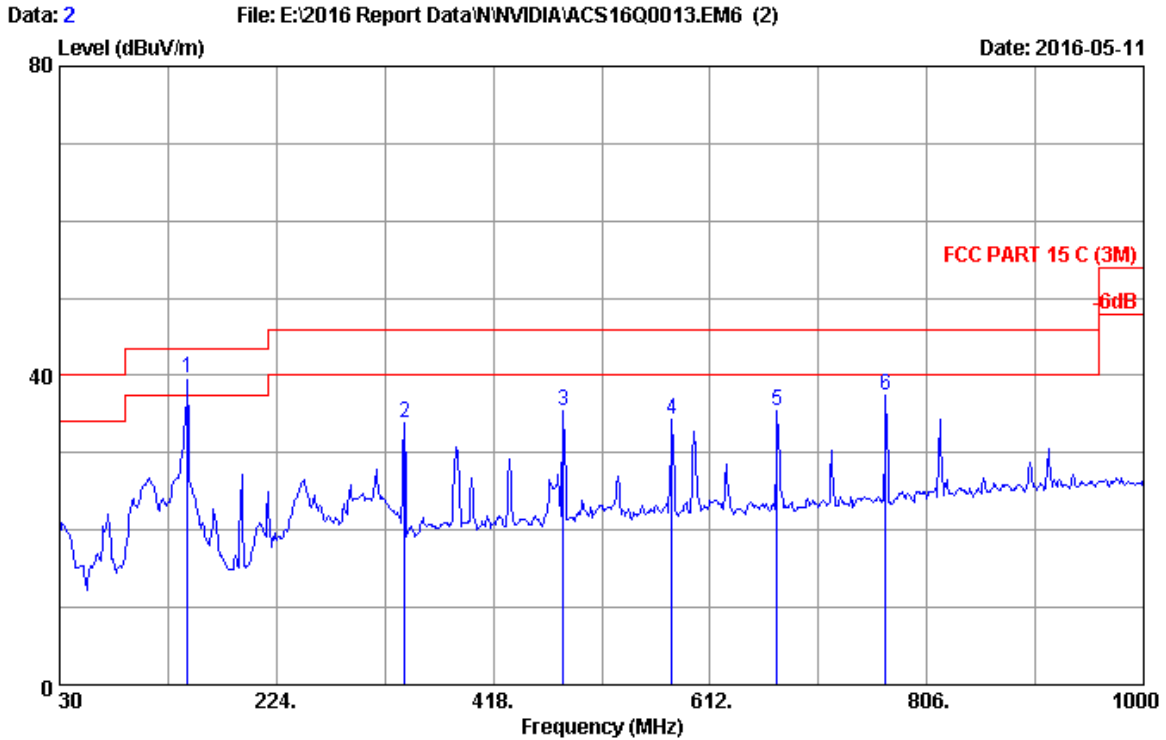

Site no. : 3m Chamber Data no. : 2
 Dis. / Ant. : 3m 2015 CBL6112D 35375 Ant. pol. : VERTICAL
 Limit : FCC PART 15 C (3M)
 Env. / Ins. : 24°C/51% Engineer : Leo_Li
 EUT : SHIELD Remote
 Power rating : DC 3V
 Test Mode : Tx Mode
 M/N:P2930

No.	Freq. (MHz)	Ant. Factor (dB/m)	Cable Loss (dB)	Reading (dBuV)	Emission Level (dBuV/m)	Limits (dBuV/m)	Margin (dB)	Remark
1	144.245	11.89	1.29	26.40	39.58	43.50	3.92	QP
2	338.460	15.25	2.01	16.72	33.98	46.00	12.02	QP
3	481.050	18.11	2.47	14.92	35.50	46.00	10.50	QP
4	578.050	19.10	2.72	12.54	34.36	46.00	11.64	QP
5	672.140	19.87	2.95	12.62	35.44	46.00	10.56	QP
6	769.140	20.79	3.19	13.40	37.38	46.00	8.62	QP

Remarks: 1. Emission Level= Antenna Factor + Cable Loss + Reading.
 2. The emission levels that are 20dB below the official limit are not reported.

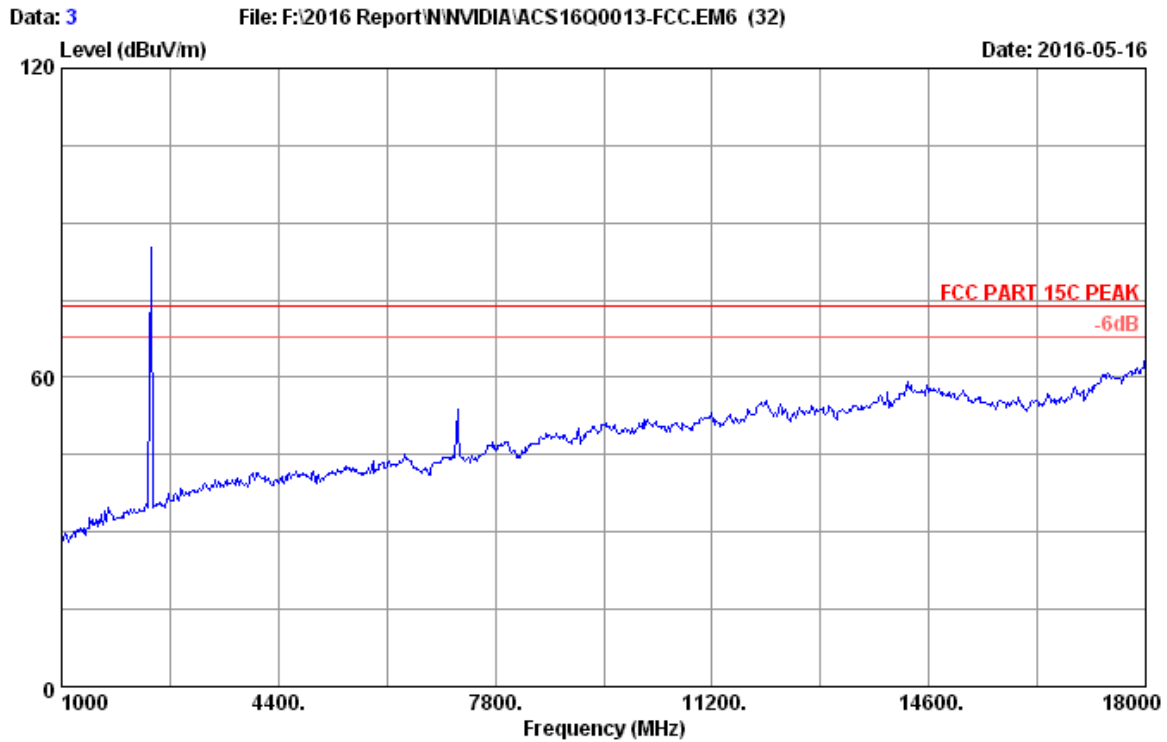
Frequency: 1GHz~18GHz
GFSK 2402MHz

Site no. : 3m Chamber Data no. : 3
Dis. / Ant. : 3m 2016 3115(4580) Ant. pol. : HORIZONTAL
Limit : FCC PART 15C PEAK
Env. / Ins. : 23.2*C/55%
Engineer : Leo-Li
EUT : SHIELD Remote
Power rating : DC 3V
Test Mode : GFSK 2402MHz Tx
M/N : P2930

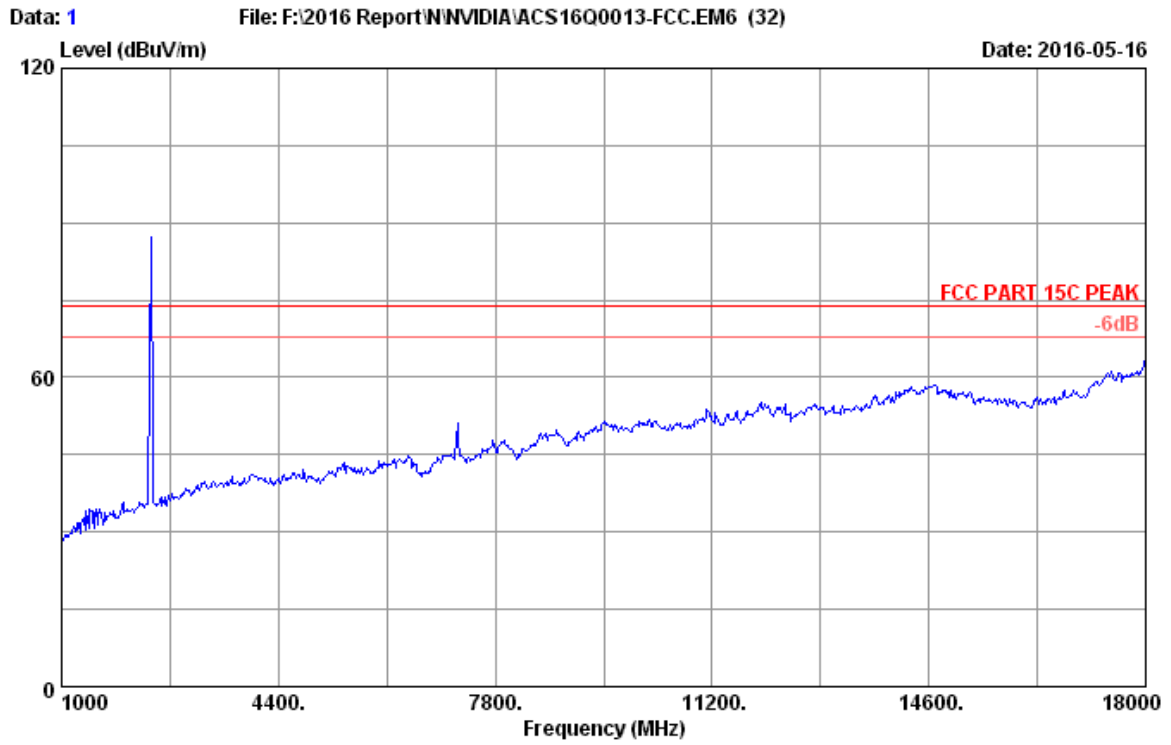

Site no.	: 3m Chamber	Data no.	: 1
Dis. / Ant.	: 3m 2016 3115(4580)	Ant. pol.	: VERTICAL
Limit	: FCC PART 15C PEAK		
Env. / Ins.	: 23.2*C/55%		
Engineer	: Leo-Li		
EUT	: SHIELD Remote		
Power rating	: DC 3V		
Test Mode	: GFSK 2402MHz Tx		
M/N	: P2930		

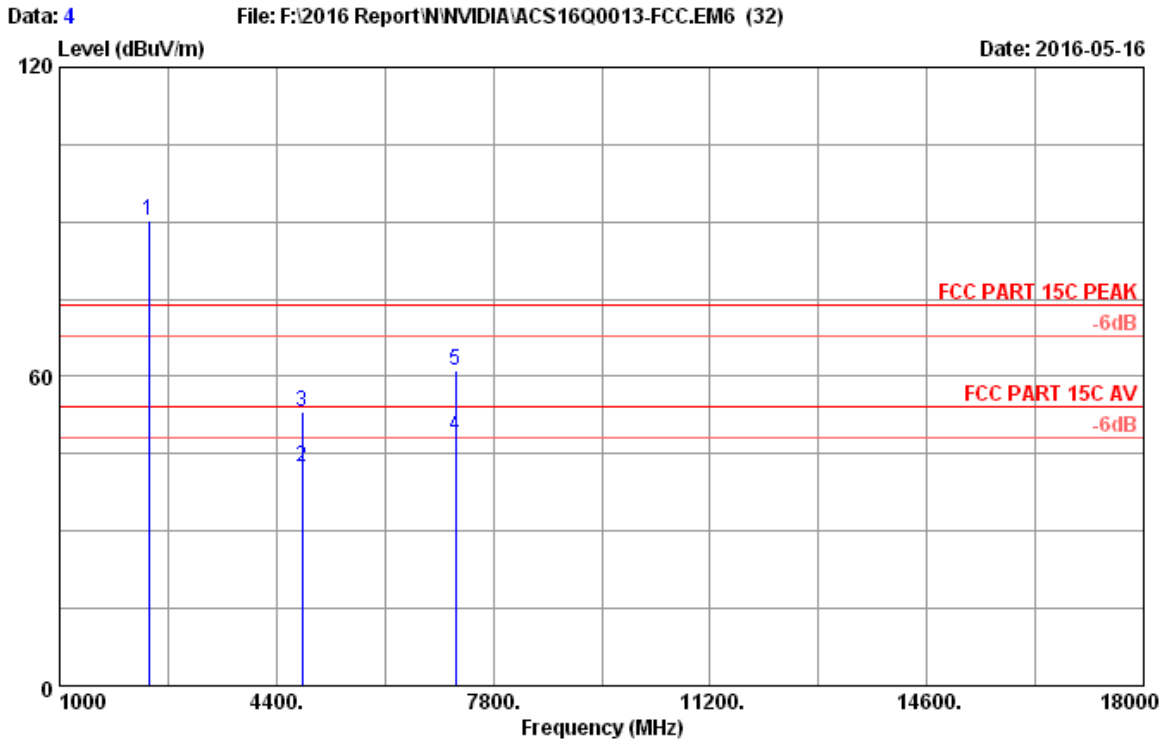

Site no. : 3m Chamber Data no. : 4
 Dis. / Ant. : 3m 2016 3115(4580) Ant. pol. : HORIZONTAL
 Limit : FCC PART 15C PEAK
 Env. / Ins. : 23.2°C/55%
 Engineer : Leo-Li
 EUT : SHIELD Remote
 Power rating : DC 3V
 Test Mode : GFSK 2402MHz Tx
 M/N : P2930

No.	Freq. (MHz)	Ant. Factor (dB/m)	Cable Loss (dB)	AMP factor (dB)	Reading (dBuV)	Emission Level (dBuV/m)	Limits (dBuV/m)	Margin (dB)	Remark
1	2402.000	28.24	8.34	36.39	90.06	90.25	74.00	-16.25	Peak
2	4804.000	32.93	11.75	35.67	33.60	42.61	54.00	11.39	Average
3	4804.000	32.93	11.75	35.67	44.04	53.05	74.00	20.95	Peak
4	7206.000	35.78	12.44	35.55	35.73	48.40	54.00	5.60	Average
5	7206.000	35.78	12.44	35.55	48.40	61.07	74.00	12.93	Peak

Remarks: 1. Emission Level= Antenna Factor + Cable Loss + Reading - Amp Factor
 2. The emission levels that are 20dB below the official limit are not reported.

Frequency (MHz)	Original AV Reading (dBuV/m)	Duty cycle factor (dB)	Final AV level (dBuV/m)	Limit (dBuV/m)	Margin	Conclusion
4804	42.61	1.593	44.203	54	9.797	Pass
7206	48.40	1.593	49.993	54	4.007	Pass

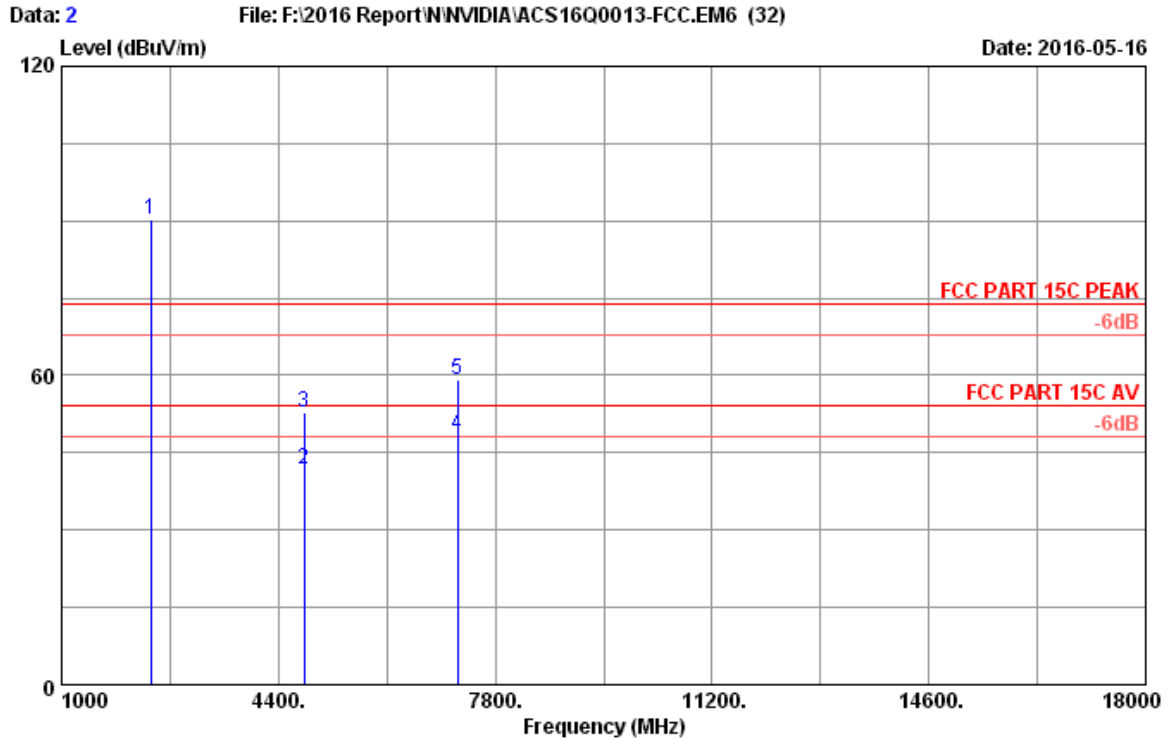

Site no. : 3m Chamber Data no. : 2
 Dis. / Ant. : 3m 2016 3115(4580) Ant. pol. : VERTICAL
 Limit : FCC PART 15C PEAK
 Env. / Ins. : 23.2*C/55%
 Engineer : Leo-Li
 EUT : SHIELD Remote
 Power rating : DC 3V
 Test Mode : GFSK 2402MHz Tx
 M/N : P2930

No.	Freq. (MHz)	Ant. Factor (dB/m)	Cable Loss (dB)	AMP factor (dB)	Reading (dBuV)	Emission Level (dBuV/m)	Limits (dBuV/m)	Margin (dB)	Remark
1	2402.000	28.24	8.34	36.39	90.14	90.33	74.00	-16.33	Peak
2	4804.000	32.93	11.75	35.67	32.82	41.83	54.00	12.17	Average
3	4804.000	32.93	11.75	35.67	43.82	52.83	74.00	21.17	Peak
4	7206.000	35.78	12.44	35.55	35.82	48.49	54.00	5.51	Average
5	7206.000	35.78	12.44	35.55	46.34	59.01	74.00	14.99	Peak

Remarks: 1. Emission Level= Antenna Factor + Cable Loss + Reading - Amp Factor
 2. The emission levels that are 20dB below the official limit are not reported.

Frequency (MHz)	Original AV Reading (dBuV/m)	Duty cycle factor (dB)	Final AV level (dBuV/m)	Limit (dBuV/m)	Margin	Conclusion
4804	41.83	1.593	43.423	54	10.577	Pass
7206	48.49	1.593	50.083	54	3.917	Pass

GFSK 2440MHz

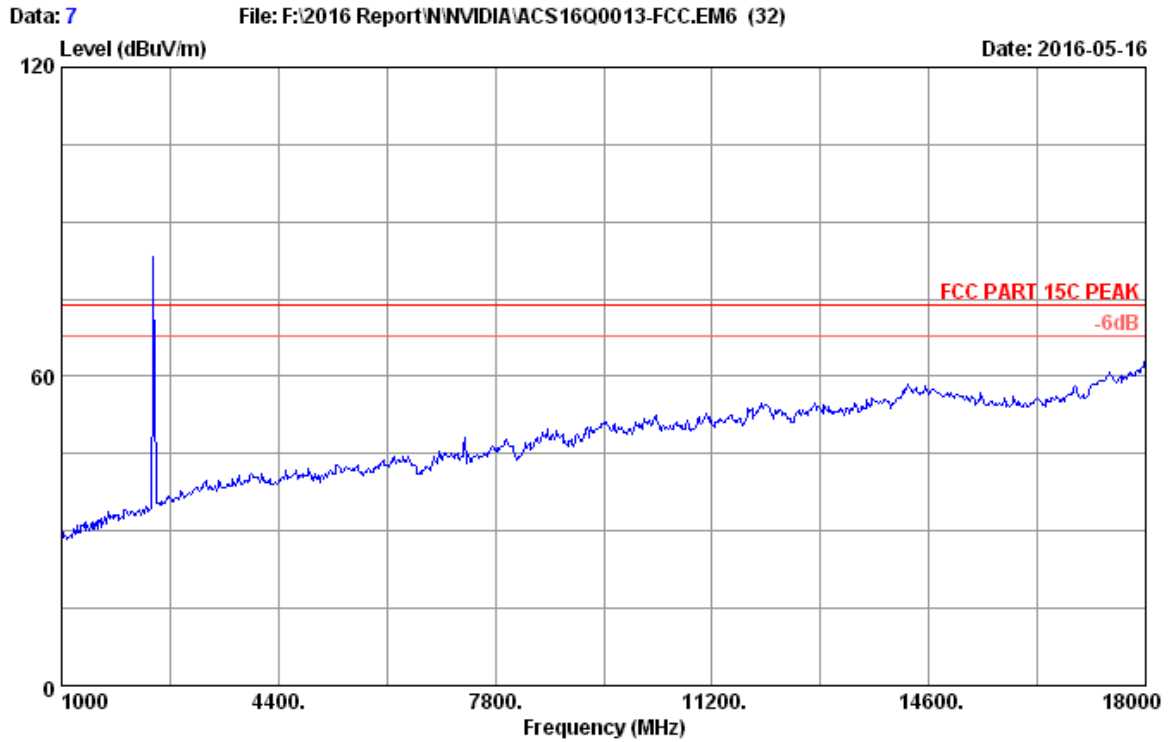

Site no.	: 3m Chamber	Data no.	: 7
Dis. / Ant.	: 3m 2016 3115(4580)	Ant. pol.	: HORIZONTAL
Limit	: FCC PART 15C PEAK		
Env. / Ins.	: 23.2*C/55%		
Engineer	: Leo-Li		
EUT	: SHIELD Remote		
Power rating	: DC 3V		
Test Mode	: GFSK 2440MHz Tx		
M/N	: P2930		

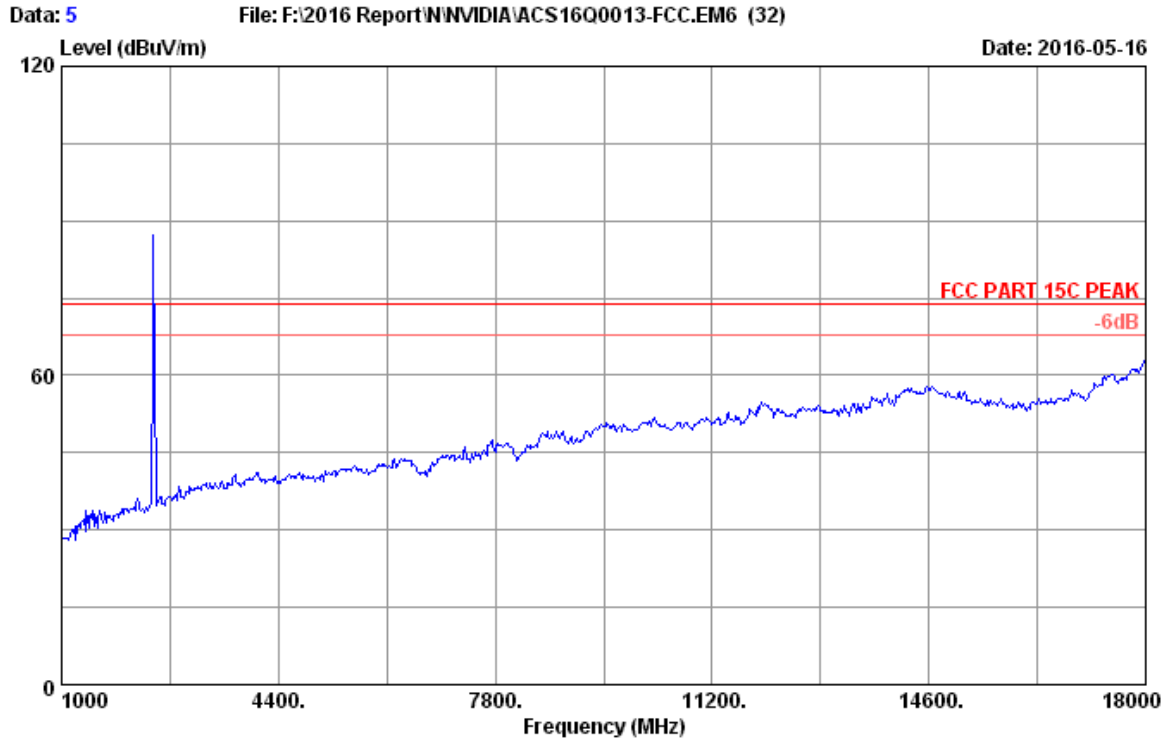

Site no. : 3m Chamber Data no. : 5
Dis. / Ant. : 3m 2016 3115(4580) Ant. pol. : VERTICAL
Limit : FCC PART 15C PEAK
Env. / Ins. : 23.2*C/55%
Engineer : Leo-Li
EUT : SHIELD Remote
Power rating : DC 3V
Test Mode : GFSK 2440MHz Tx
M/N : P2930

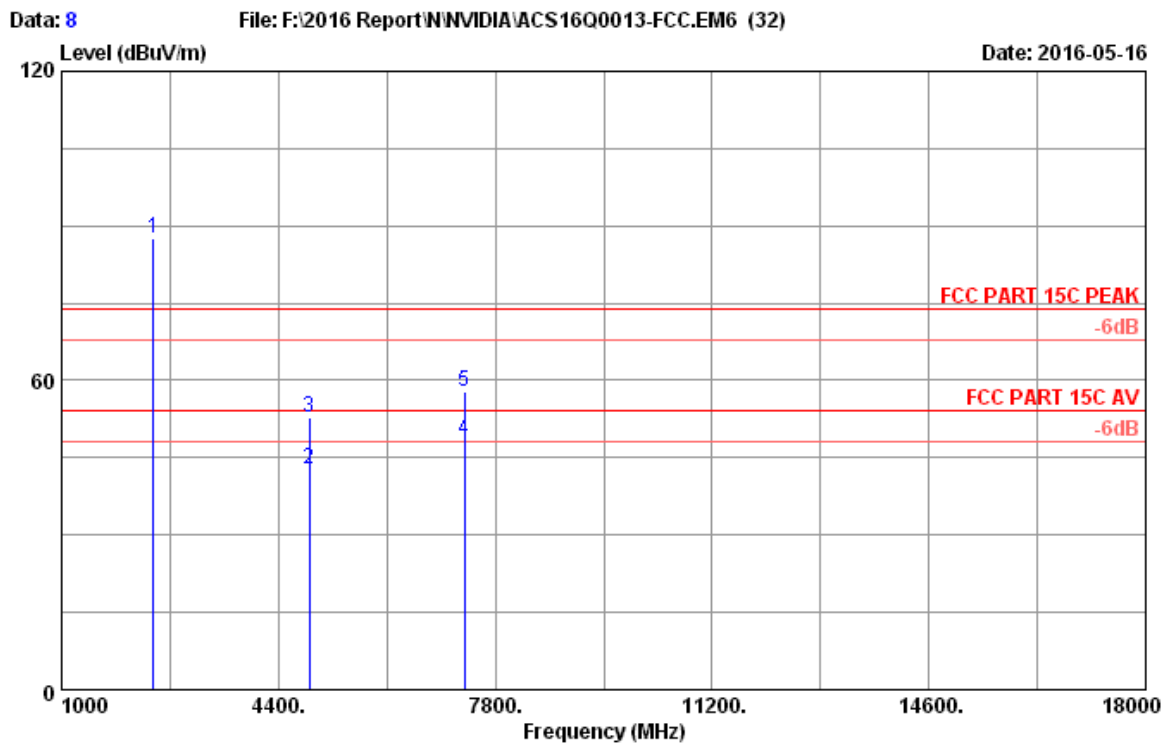

Site no. : 3m Chamber Data no. : 8
 Dis. / Ant. : 3m 2016 3115(4580) Ant. pol. : HORIZONTAL
 Limit : FCC PART 15C PEAK
 Env. / Ins. : 23.2*C/55%
 Engineer : Leo-Li
 EUT : SHIELD Remote
 Power rating : DC 3V
 Test Mode : GFSK 2440MHz Tx
 M/N : P2930

No.	Freq. (MHz)	Ant. Factor (dB/m)	Cable Loss (dB)	AMP factor (dB)	Reading (dBuV)	Emission Level (dBuV/m)	Limits (dBuV/m)	Margin (dB)	Remark
1	2440.000	28.26	8.38	36.38	87.21	87.47	74.00	-13.47	Peak
2	4880.000	33.11	11.80	35.69	33.42	42.64	54.00	11.36	Average
3	4880.000	33.11	11.80	35.69	43.57	52.79	74.00	21.21	Peak
4	7320.000	36.10	12.54	35.57	35.27	48.34	54.00	5.66	Average
5	7320.000	36.10	12.54	35.57	44.80	57.87	74.00	16.13	Peak

Remarks: 1. Emission Level= Antenna Factor + Cable Loss + Reading - Amp Factor
 2. The emission levels that are 20dB below the official limit are not reported.

Frequency (MHz)	Original AV Reading (dBuV/m)	Duty cycle factor (dB)	Final AV level (dBuV/m)	Limit (dBuV/m)	Margin	Conclusion
4880	42.64	1.593	44.233	54	9.767	Pass
7320	48.34	1.593	49.933	54	4.067	Pass

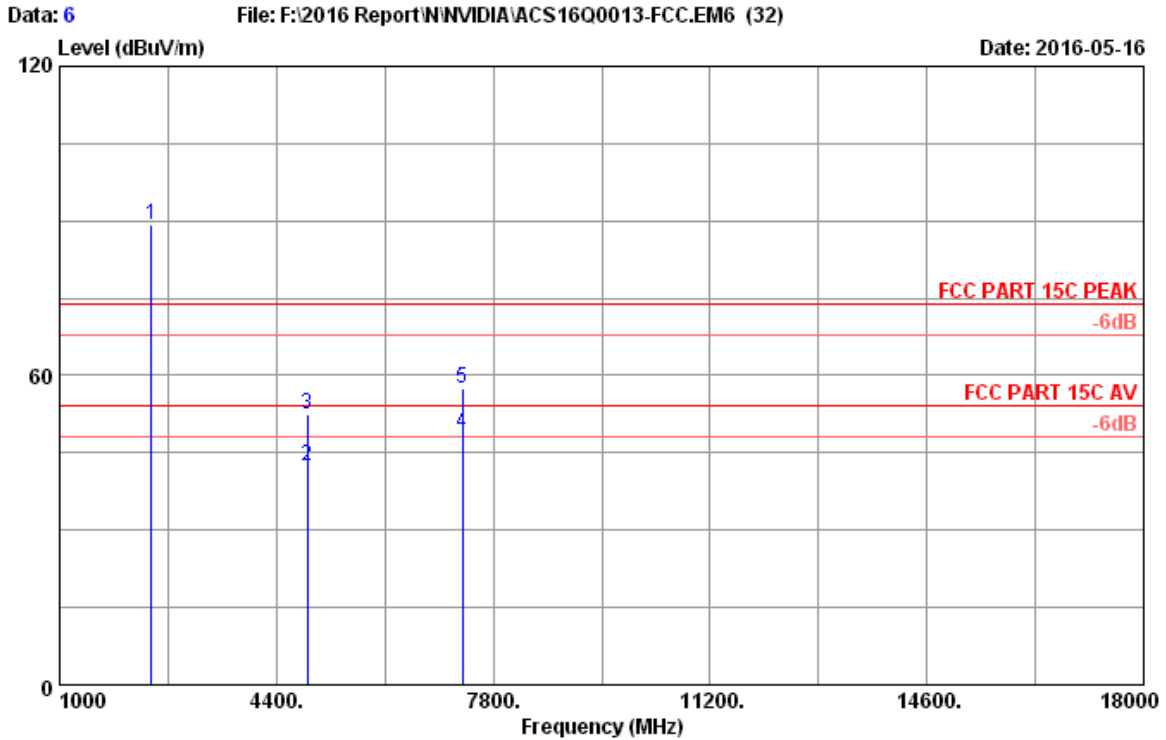

Site no. : 3m Chamber Data no. : 6
 Dis. / Ant. : 3m 2016 3115(4580) Ant. pol. : VERTICAL
 Limit : FCC PART 15C PEAK
 Env. / Ins. : 23.2*C/55%
 Engineer : Leo-Li
 EUT : SHIELD Remote
 Power rating : DC 3V
 Test Mode : GFSK 2440MHz Tx
 M/N : P2930

No.	Freq. (MHz)	Ant. Factor (dB/m)	Cable Loss (dB)	AMP factor (dB)	Reading (dBuV)	Emission Level (dBuV/m)	Limits (dBuV/m)	Margin (dB)	Remark
1	2440.000	28.26	8.38	36.38	88.85	89.11	74.00	-15.11	Peak
2	4880.000	33.11	11.80	35.69	33.16	42.38	54.00	11.62	Average
3	4880.000	33.11	11.80	35.69	43.21	52.43	74.00	21.57	Peak
4	7320.000	36.10	12.54	35.57	35.68	48.75	54.00	5.25	Average
5	7320.000	36.10	12.54	35.57	44.58	57.65	74.00	16.35	Peak

Remarks: 1. Emission Level= Antenna Factor + Cable Loss + Reading - Amp Factor
 2. The emission levels that are 20dB below the official limit are not reported.

Frequency (MHz)	Original AV Reading (dBuV/m)	Duty cycle factor (dB)	Final AV level (dBuV/m)	Limit (dBuV/m)	Margin	Conclusion
4880	42.38	1.593	43.973	54	10.027	Pass
7320	48.75	1.593	50.343	54	3.657	Pass

GFSK 2480MHz

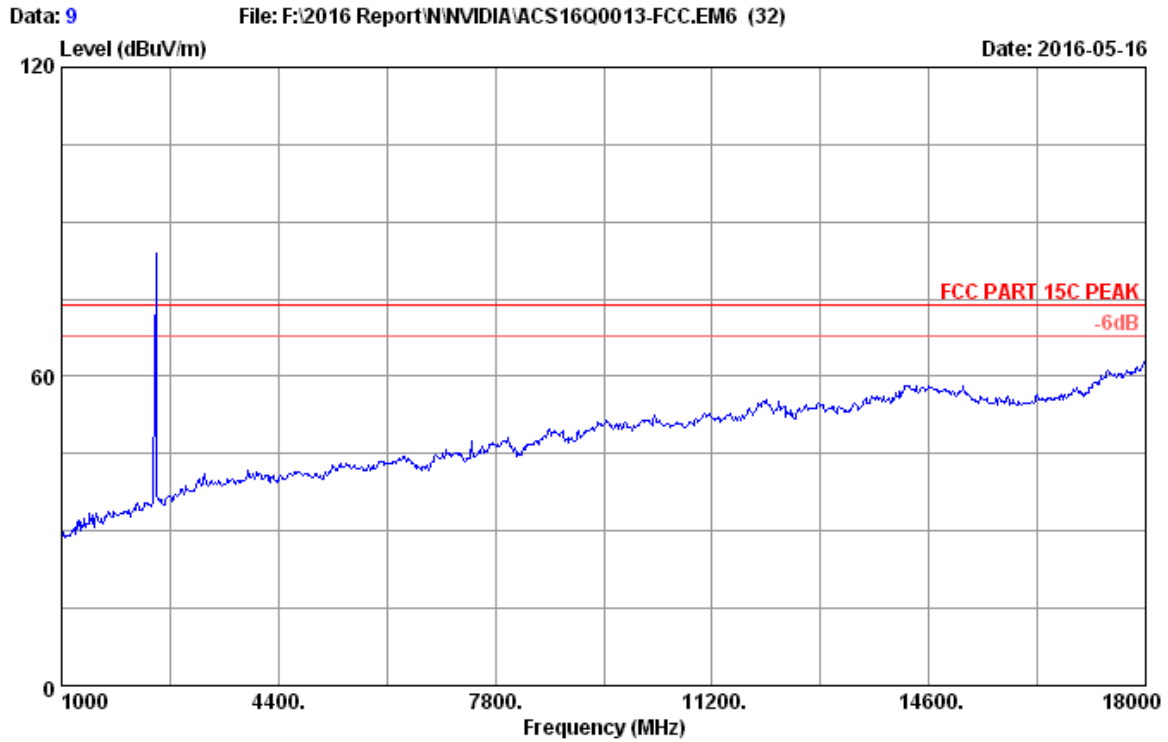

Site no. : 3m Chamber	Data no. : 9
Dis. / Ant. : 3m 2016 3115(4580)	Ant. pol. : HORIZONTAL
Limit : FCC PART 15C PEAK	
Env. / Ins. : 23.2*C/55%	
Engineer : Leo-Li	
EUT : SHIELD Remote	
Power rating : DC 3V	
Test Mode : GFSK 2480MHz Tx	
M/N : P2930	

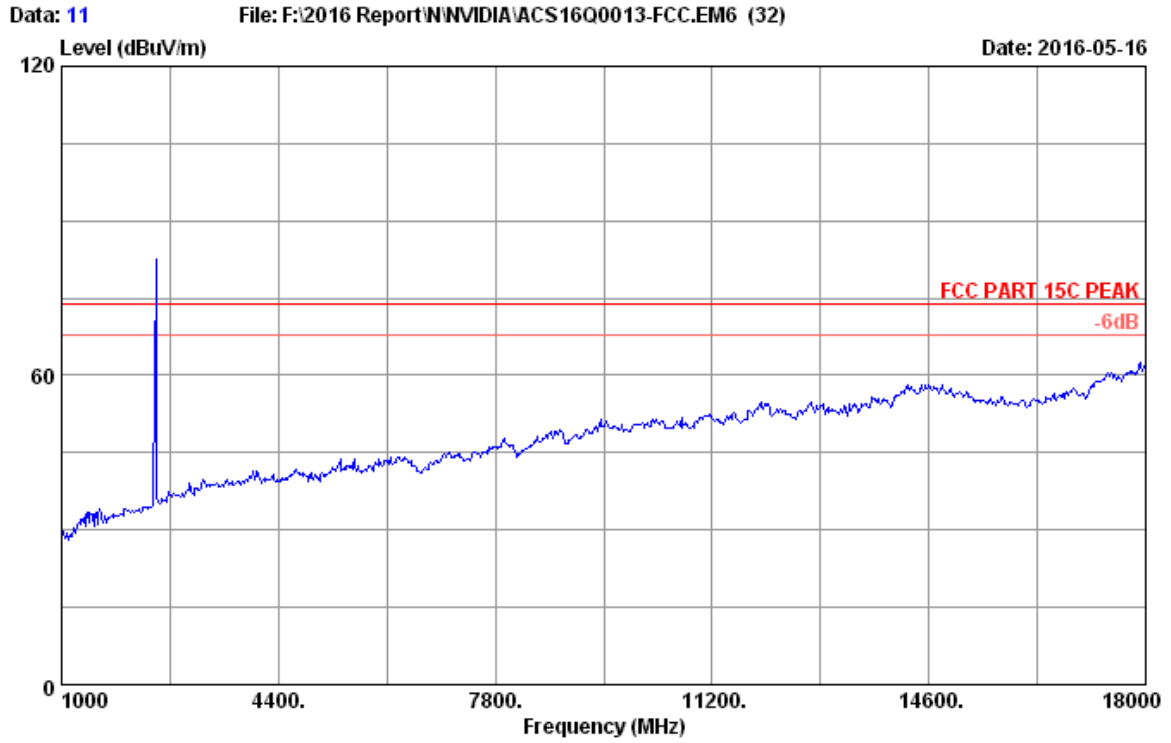

Site no.	: 3m Chamber	Data no.	: 11
Dis. / Ant.	: 3m 2016 3115(4580)	Ant. pol.	: VERTICAL
Limit	: FCC PART 15C PEAK		
Env. / Ins.	: 23.2*C/55%		
Engineer	: Leo-Li		
EUT	: SHIELD Remote		
Power rating	: DC 3V		
Test Mode	: GFSK 2480MHz Tx		
M/N	: P2930		

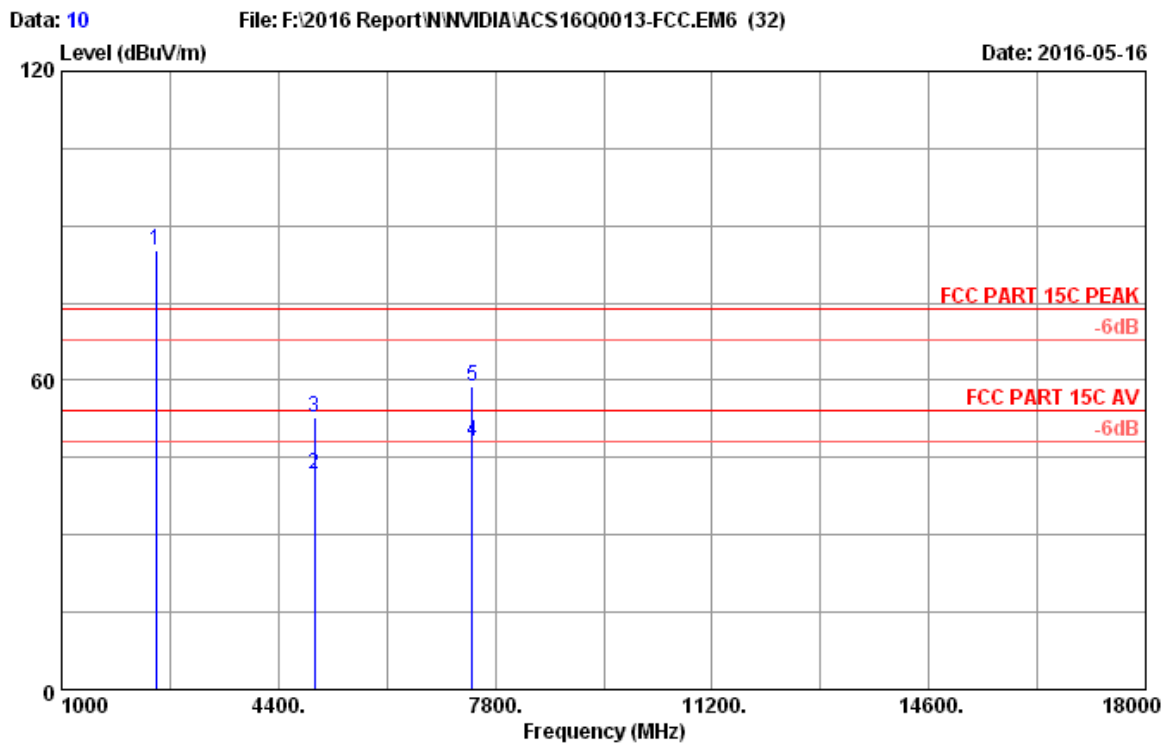

Site no. : 3m Chamber Data no. : 10
 Dis. / Ant. : 3m 2016 3115(4580) Ant. pol. : HORIZONTAL
 Limit : FCC PART 15C PEAK
 Env. / Ins. : 23.2*C/55%
 Engineer : Leo-Li
 EUT : SHIELD Remote
 Power rating : DC 3V
 Test Mode : GFSK 2480MHz Tx
 M/N : P2930

No.	Freq. (MHz)	Ant. Factor (dB/m)	Cable Loss (dB)	AMP factor (dB)	Reading (dBuV)	Emission Level (dBuV/m)	Limits (dBuV/m)	Margin (dB)	Remark
1	2480.000	28.29	8.42	36.38	84.79	85.12	74.00	-11.12	Peak
2	4960.000	33.30	11.85	35.71	32.18	41.62	54.00	12.38	Average
3	4960.000	33.30	11.85	35.71	43.36	52.80	74.00	21.20	Peak
4	7440.000	36.43	12.64	35.59	34.64	48.12	54.00	5.88	Average
5	7440.000	36.43	12.64	35.59	45.23	58.71	74.00	15.29	Peak

Remarks: 1. Emission Level= Antenna Factor + Cable Loss + Reading - Amp Factor
 2. The emission levels that are 20dB below the official limit are not reported.

Frequency (MHz)	Original AV Reading (dBuV/m)	Duty cycle factor (dB)	Final AV level (dBuV/m)	Limit (dBuV/m)	Margin	Conclusion
4960	41.62	1.593	43.213	54	10.787	Pass
7440	48.12	1.593	49.713	54	4.287	Pass

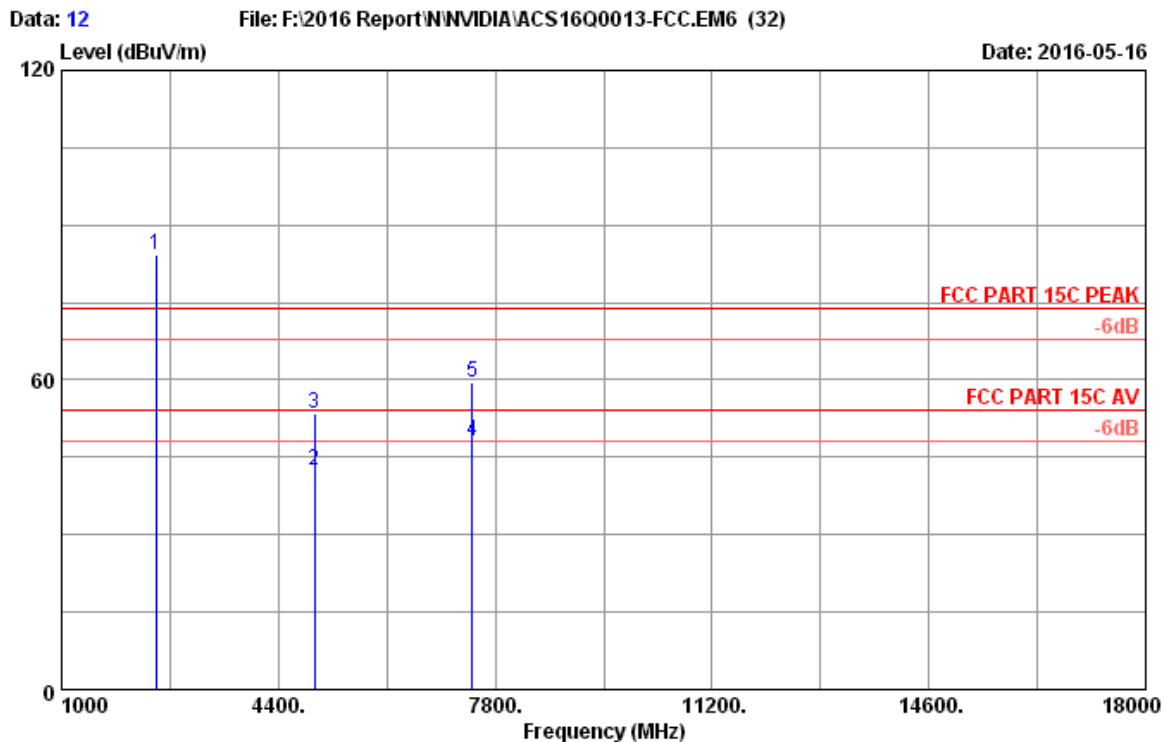

Site no. : 3m Chamber Data no. : 12
 Dis. / Ant. : 3m 2016 3115(4580) Ant. pol. : VERTICAL
 Limit : FCC PART 15C PEAK
 Env. / Ins. : 23.2*C/55%
 Engineer : Leo-Li
 EUT : SHIELD Remote
 Power rating : DC 3V
 Test Mode : GFSK 2480MHz Tx
 M/N : P2930

No.	Freq. (MHz)	Ant. Factor (dB/m)	Cable Loss (dB)	AMP factor (dB)	Reading (dBuV)	Emission Level (dBuV/m)	Limits (dBuV/m)	Margin (dB)	Remark
1	2480.000	28.29	8.42	36.38	84.03	84.36	74.00	-10.36	Peak
2	4960.000	33.30	11.85	35.71	33.02	42.46	54.00	11.54	Average
3	4960.000	33.30	11.85	35.71	44.13	53.57	74.00	20.43	Peak
4	7440.000	36.43	12.64	35.59	34.59	48.07	54.00	5.93	Average
5	7440.000	36.43	12.64	35.59	45.88	59.36	74.00	14.64	Peak

Remarks: 1. Emission Level= Antenna Factor + Cable Loss + Reading - Amp Factor
 2. The emission levels that are 20dB below the official limit are not reported.

Frequency (MHz)	Original AV Reading (dBuV/m)	Duty cycle factor (dB)	Final AV level (dBuV/m)	Limit (dBuV/m)	Margin	Conclusion
4960	42.46	1.593	44.053	54	9.947	Pass
7440	48.07	1.593	49.663	54	4.337	Pass

5. CONDUCTED SPURIOUS EMISSIONS

5.1. Test Equipment

Item	Equipment	Manufacturer	Model No.	Serial No.	Last Cal.	Cal. Interval
1.	Spectrum	Agilent	N9030A	MY51380221	Oct.17,15	1 Year
2.	Attenuator (20dB)	Agilent	8491B	MY39262165	Apr.23,16	1 Year
3.	RF Cable	Marvelous Microwave Inc	SFL402105FLEX	NO.1	Oct.17,15	1 Year

5.2. Limit

In any 100kHz bandwidth outside the frequency bands in which the spread spectrum intentional radiator is operating, the radio frequency power that is produced by the intentional radiator shall be at least 20dB below that in the 100kHz bandwidth within the band that contains the highest level of the desired power.

5.3. Test Procedure

The transmitter output was connected to a spectrum analyzer, The resolution bandwidth is set to 100 kHz, The video bandwidth is set to 300 kHz and measure all the emissions With peak detector.

5.4. Test result

PASS (The testing data was attached in the next pages.)

<p>GFSK</p>	
<p>2402MHz(30MHz-1GHz)</p>	<p>2402MHz(2.31GHz-2.405GHz)</p>
<p>2402MHz(1GHz-10GHz)</p>	<p>2440MHz(30MHz-1GHz)</p>
<p>2402MHz(10GHz-25GHz)</p>	<p>2440MHz(1GHz-10GHz)</p>

2440MHz(10GHz-25GHz)

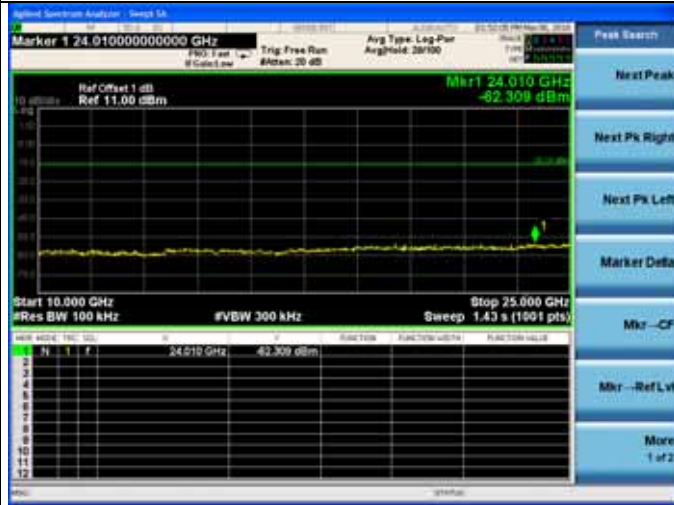

2480MHz(10GHz-25GHz)

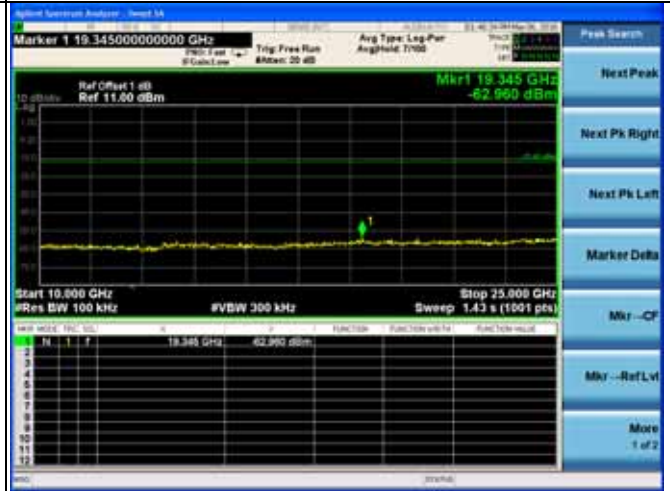

2480MHz(30MHz-1GHz)

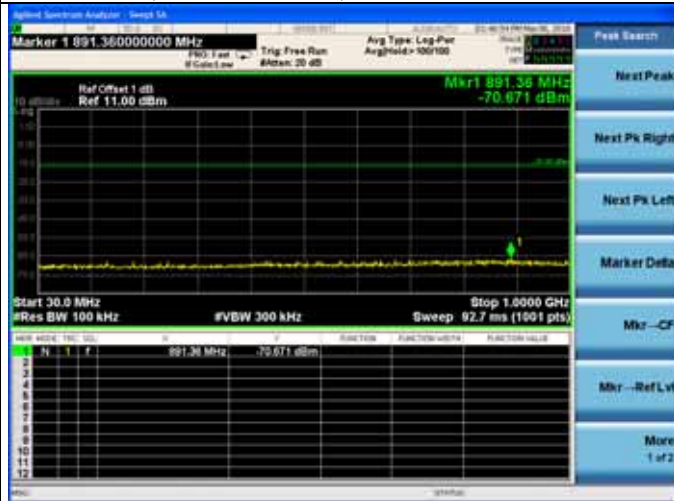

2480MHz(2.477GHz-2.51GHz)



2480MHz(1GHz-10GHz)

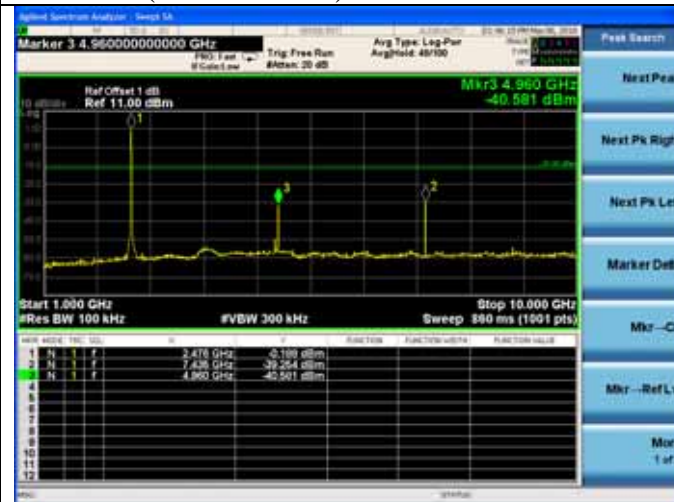

6. 6dB BANDWIDTH TEST

6.1. Test Equipment

Item	Equipment	Manufacturer	Model No.	Serial No.	Last Cal.	Cal. Interval
1.	Spectrum	Agilent	N9030A	MY51380221	Oct.18,15	1Year
2.	Attenuator (20dB)	Agilent	8491B	MY39262165	Apr.23,16	1 Year
3.	RF Cable	Marvelous Microwave Inc	SFL402105FLEX	NO.1	Oct.17.15	1 Year

6.2. Limit

For direct sequence systems, the minimum 6dB bandwidth shall be at least 500kHz.

6.3. Test Procedure

The transmitter output was connected to a spectrum analyzer, The bandwidth of the fundamental frequency was measured by spectrum analyzer with 100kHz RBW and 300KHz VBW. The 6dB bandwidth is defined as the total spectrum the power of which is higher than peak power minus 6dB.

6.4. Test Results

EUT: SHIELD Remote		
M/N: P2930		
Test date: 2016-05-06	Pressure: 101.8±1.0 kpa	Humidity: 52.7±3.0%
Tested by: Leo_li	Test site: RF site	Temperature:22.6±0.6

Test Mode	Frequency (MHz)	6 dB bandwidth (kHz)	Limit (KHz)
GFSK	2402	725.7	>500
	2440	722.9	>500
	2480	720.3	>500
Conclusion : PASS			

<p>GFSK</p>	
<p>2402MHz</p>	<p>2480MHz</p>
<p>2440MHz</p>	

7. MAXIMUM PEAK OUTPUT POWER TEST

7.1. Test Equipment

Item	Equipment	Manufacturer	Model No.	Serial No.	Last Cal.	Cal. Interval
1.	Spectrum	Agilent	N9030A	MY51380221	Oct.18,15	1 Year
2.	Power meter	Anritsu	ML2487A	6K00002472	Aug.21,15	1 Year
3.	Power sensor	Anritsu	MA2491A	0033005	Aug.21,15	1 Year
4.	Attenuator (20dB)	Agilent	8491B	MY39262165	Apr.23,16	1 Year
5.	RF Cable	Marvelous Microwave Inc	SFL402105FLEX	NO.1	Oct.17,15	1 Year

7.2. Limit

For systems using digital modulation in the 2400—2483.5MHz, The Peak out put Power shall not exceed 1W(30dBm).

7.3. Test Procedure

Connected the EUT’s antenna port to Power Sensor, and use power meter to test peak output power.

7.4. Test Results

EUT: SHIELD Remote			
M/N: P2930			
Test date: 2016-05-06		Pressure: 101.7±1.0 kpa	Humidity: 52.7±3.0%
Tested by: Leo_li		Test site: RF site	Temperature:22.5±0.6
Test Mode	Frequency (MHz)	Peak output Power (dBm)	Limit (dBm)
GFSK	2402	0.845	30
	2440	0.909	30
	2480	0.662	30
Conclusion: PASS			

8. BAND EDGE COMPLIANCE TEST

8.1. Test Equipment

Item	Equipment	Manufacturer	Model No.	Serial No.	Last Cal.	Cal. Interval
1.	Spectrum	Agilent	E4446A	US44300459	Apr.24,16	1 Year
2.	Amp	HP	8449B	3008A02495	Apr.24,16	1 Year
3.	Horn Antenna	ETS	3115	9510-4877	Oct.15,15	1 Year
4.	HF Cable	Hubersuhner	Sucoflex104	274094/4	Apr.24,16	1 Year

8.2. Limit

All the lower and upper band-edges emissions appearing within 2310MHz to 2390MHz and 2483.5MHz to 2500MHz restricted frequency bands shall not exceed the limits shown in 15.209, all the other emissions outside operation frequency band 2400MHz to 2483.5MHz shall be at least 20dB below the fundamental emissions, or comply with 15.209 limits.

8.3. Test Produce

For upper band emissions that are up to two bandwidths(2MHz) away (2483.5MHz to 2485.5MHz) from the band-edge use below produce:

1. Choose a spectrum analyzer span that encompasses both the peak of the fundamental emission and the band-edge emission under investigation. Set the analyzer RBW to 100KHz and with a video bandwidth 300KHz. Record the peak levels of the fundamental emission and the relevant band-edge emission, Observe the stored trace and measure the amplitude delta between the peak of the fundamental and the peak of the band-edge emission. This is not a field strength measurement, it is only a relative measurement to determine the amount by which the emission drops at the band edge relative to the highest fundamental emission level.
2. Subtract the delta measured in step (1) from the maximum field strengths measured in clause 4 .The resultant field strengths are then used to determine band-edge compliance as required by Section 15.205

For emissions above two bandwidths away from the band-edge use below produce:

1. The EUT is placed on a turntable, which is 0.8m above the ground plane and worked at highest radiated power.
2. The turntable was rotated for 360 degrees to determine the position of maximum emission level.
3. EUT is set 3m away from the receiving antenna, which is varied from 1m to 4m to find out the highest emission.
4. Set the spectrum analyzer in the following setting in order to capture the lower and upperband-edges of the emission:
 - (a) PEAK: RBW=1MHz ;VBW=3MHz, PK detector, Sweep=AUTO
 - (b) This is pulse Modulation device a duty cycle factor was used to calculate average level based measured peak level.

8.4. Test Results

Pass (The testing data was attached in the next pages.)

Note: If the PK measured levels comply with average limit, then the average level were deemed to comply with average limit.

2402MHz Mark delta=53.035dB

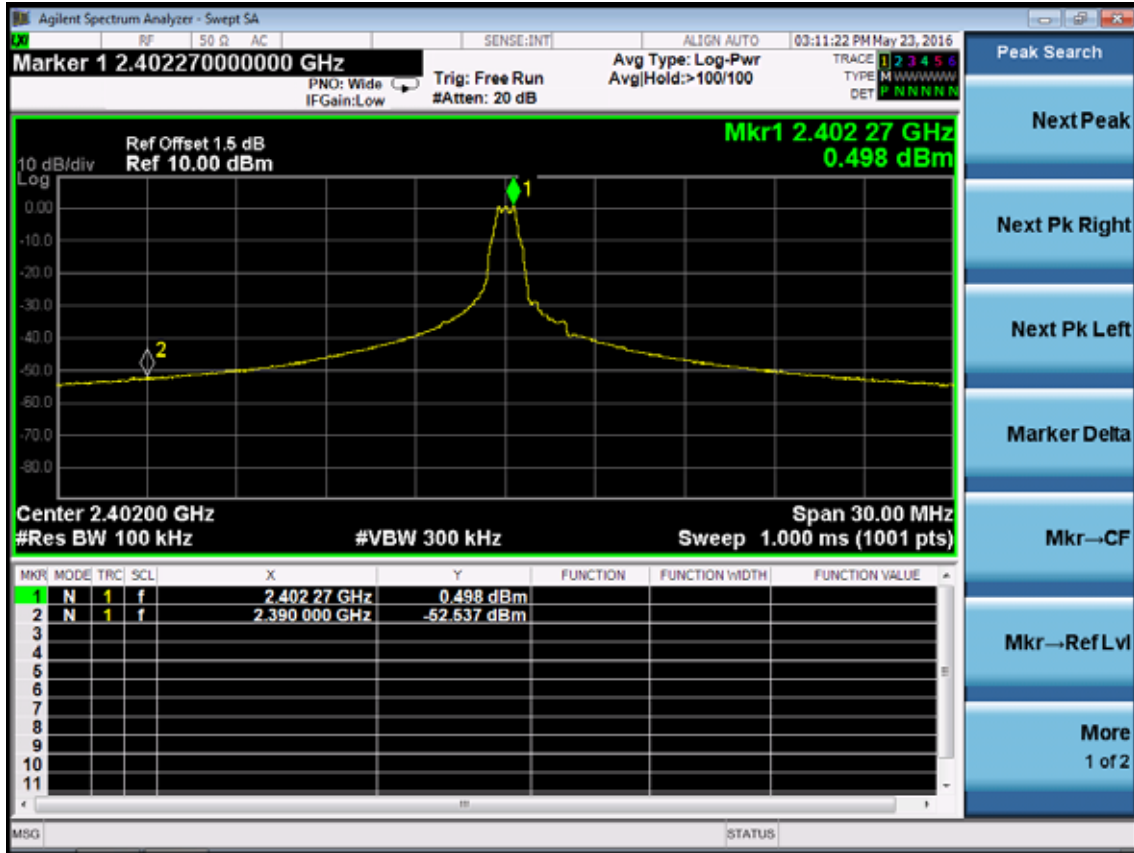

2480MHz Mark delta=64.911dB

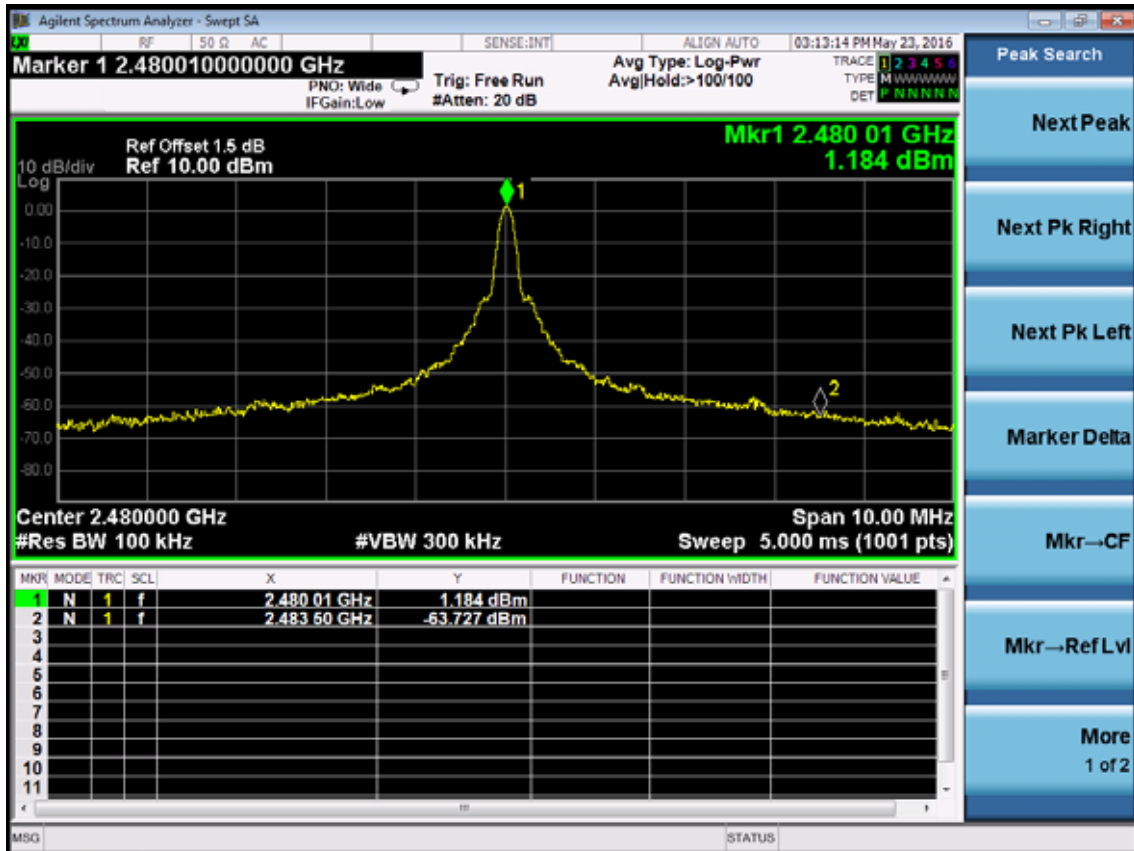

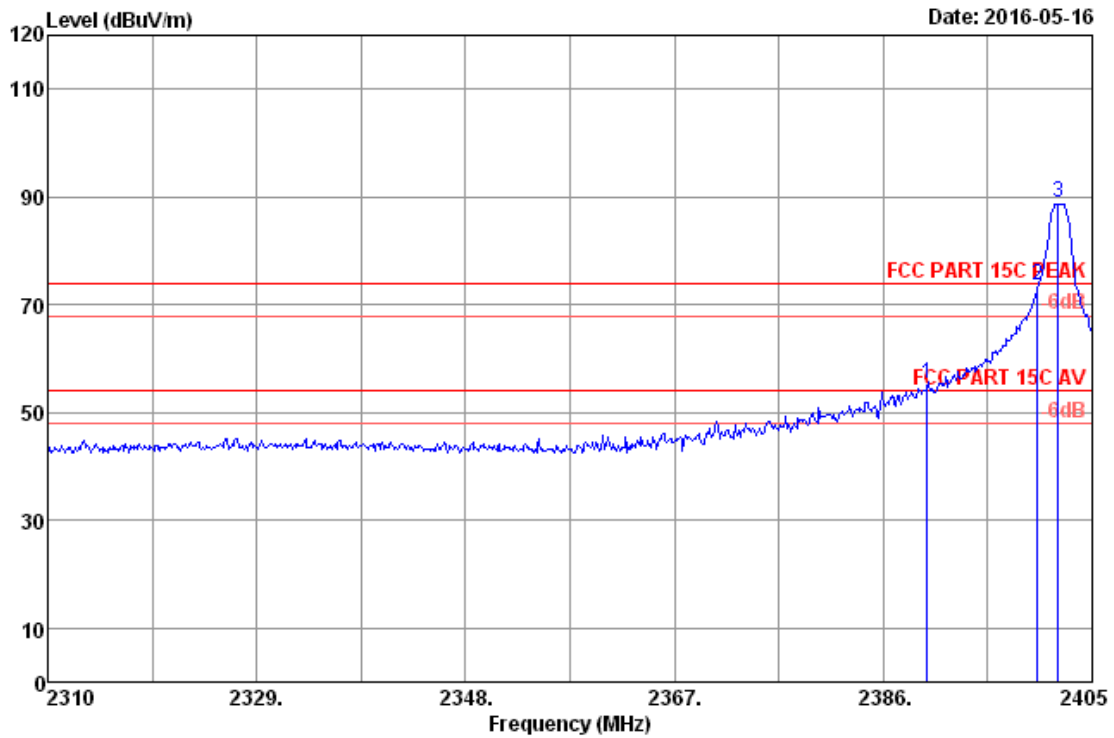

Site no. : RF Chamber Data no. : 13
 Dis. / Ant. : 3m 2016 3115(4580) Ant. pol. : HORIZONTAL
 Limit : FCC PART 15C PEAK Pre : 101.2kPa
 Env. / Ins. : 22.6°C/51.2% Engineer : Leo-Li
 EUT : SHIELD Remote
 Power rating : DC 3V
 Test Mode : GFSK 2402MHz Tx
 M/N : P2930

No.	Freq. (MHz)	Ant. Factor (dB/m)	Cable Loss (dB)	Reading (dBuV)	AMP factor (dB)	Emission Level (dBuV/m)	Limits (dBuV/m)	Margin (dB)	Remark
1	2390.00	28.23	8.33	55.30	36.39	55.47	74.00	18.53	Peak
2	2400.00	28.24	8.34	73.30	36.39	73.49	74.00	0.51	Peak
3	2401.87	28.24	8.34	88.81	36.39	89.00	74.00	-15.00	Peak

Remarks: 1. Emission Level= Antenna Factor + Cable Loss + Reading - Amp Factor
 2. The emission levels that are 20dB below the official limit are not reported.

Frequency (MHz)	Original Peak level (dBuv/m)	Mark delta (dB)	Final AV level (dBuv/m)	Limit(dBuv/m)	Conclusion
2390.00	89.00	53.035	35.965	74	Pass

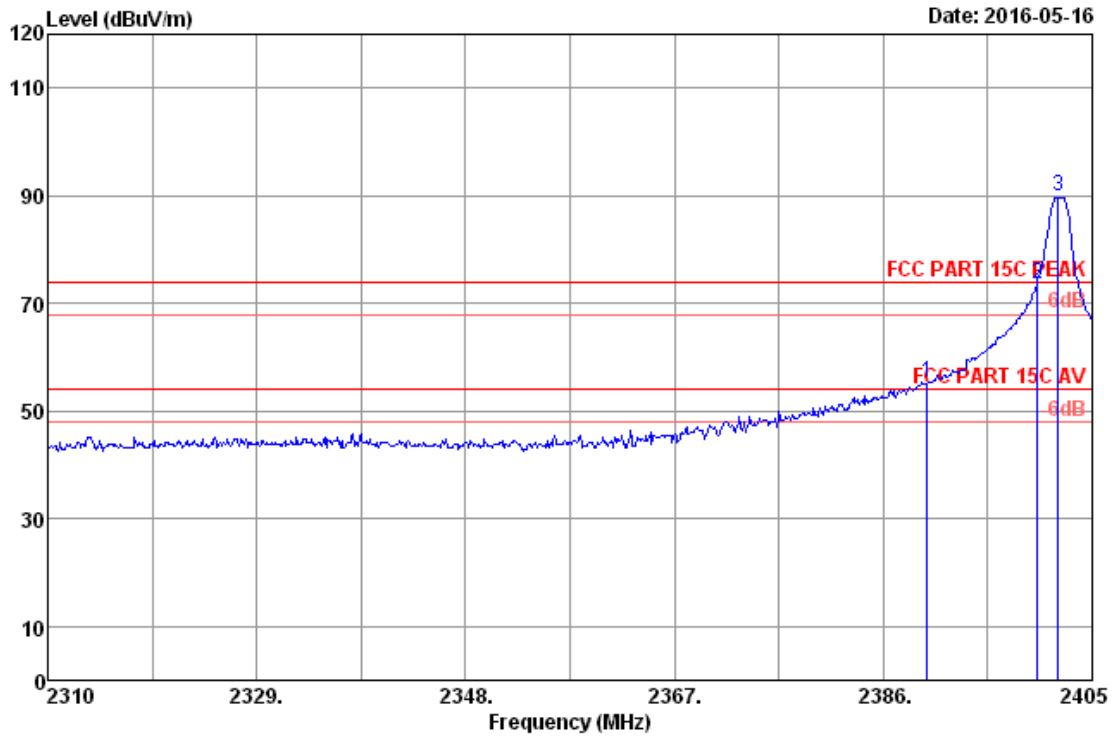

Site no. : RF Chamber Data no. : 14
 Dis. / Ant. : 3m 2016 3115(4580) Ant. pol. : VERTICAL
 Limit : FCC PART 15C PEAK Pre : 101.2kPa
 Env. / Ins. : 22.6*C/51.2% Engineer : Leo-Li
 EUT : SHIELD Remote
 Power rating : DC 3V
 Test Mode : GFSK 2402MHz Tx
 M/N : P2930

No.	Freq. (MHz)	Ant. Factor (dB/m)	Cable Loss (dB)	Reading (dBuV)	AMP factor (dB)	Emission Level (dBuV/m)	Limits (dBuV/m)	Margin (dB)	Remark
1	2390.00	28.23	8.33	55.21	36.39	55.38	74.00	18.62	Peak
2	2400.00	28.24	8.34	73.42	36.39	73.61	74.00	0.39	Peak
3	2401.87	28.24	8.34	89.75	36.39	89.94	74.00	-15.94	Peak

Remarks: 1. Emission Level= Antenna Factor + Cable Loss + Reading - Amp Factor
 2. The emission levels that are 20dB below the official limit are not reported.

Frequency (MHz)	Original Peak level (dBuv/m)	Mark delta (dB)	Final AV level (dBuv/m)	Limit(dBuv/m)	Conclusion
2390.00	89.94	53.035	36.905	74	Pass

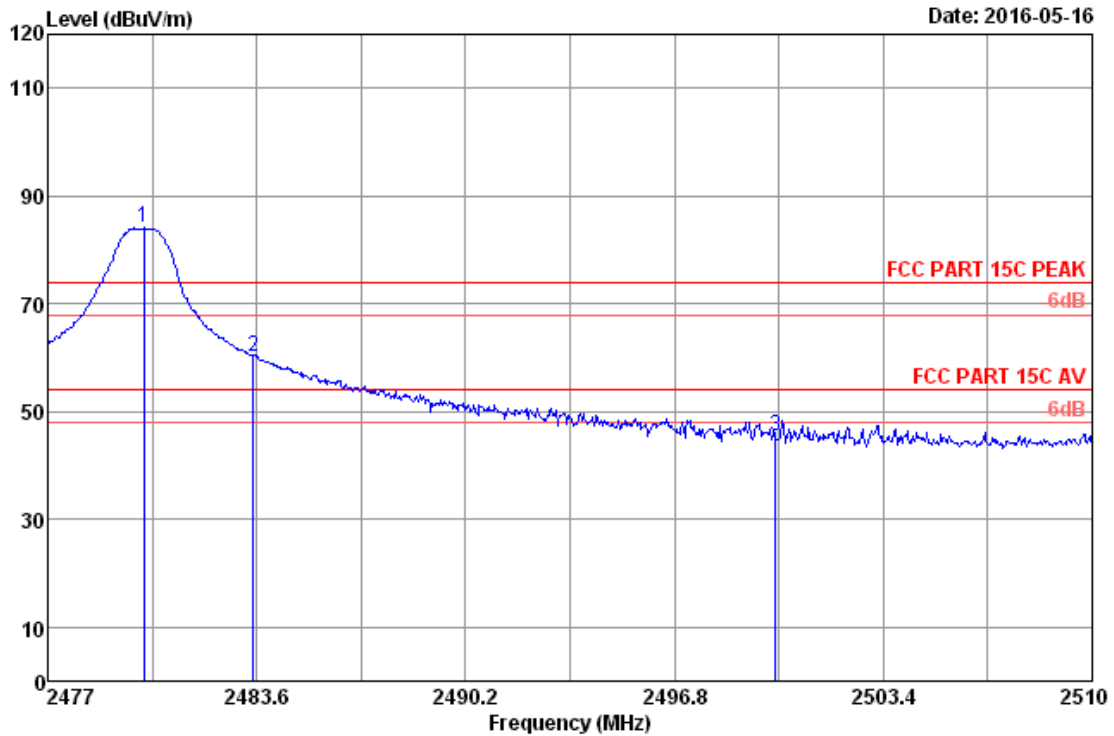

Site no.	: RF Chamber	Data no.	: 16
Dis. / Ant.	: 3m 2016 3115(4580)	Ant. pol.	: HORIZONTAL
Limit	: FCC PART 15C PEAK	Pre	: 101.2kPa
Env. / Ins.	: 22.6°C/51.2%	Engineer	: Leo-Li
EUT	: SHIELD Remote		
Power rating	: DC 3V		
Test Mode	: GFSK 2480MHz Tx		
M/N	: P2930		

No.	Freq. (MHz)	Ant. Factor (dB/m)	Cable Loss (dB)	Reading (dBUV)	AMP factor (dB)	Emission Level (dBUV/m)	Limits (dBUV/m)	Margin (dB)	Remark
1	2480.04	28.29	8.42	83.69	36.38	84.02	74.00	-10.02	Peak
2	2483.50	28.29	8.42	59.77	36.38	60.10	74.00	13.90	Peak
3	2500.00	28.30	8.44	45.24	36.38	45.60	74.00	28.40	Peak

Remarks: 1. Emission Level= Antenna Factor + Cable Loss + Reading - Amp Factor
 2. The emission levels that are 20dB below the official limit are not reported.

Frequency (MHz)	Original Peak level (dBuv/m)	Mark delta (dB)	Final AV level (dBuv/m)	Limit(dBuv/m)	Conclusion
2483.50	84.02	64.911	19.109	74	Pass

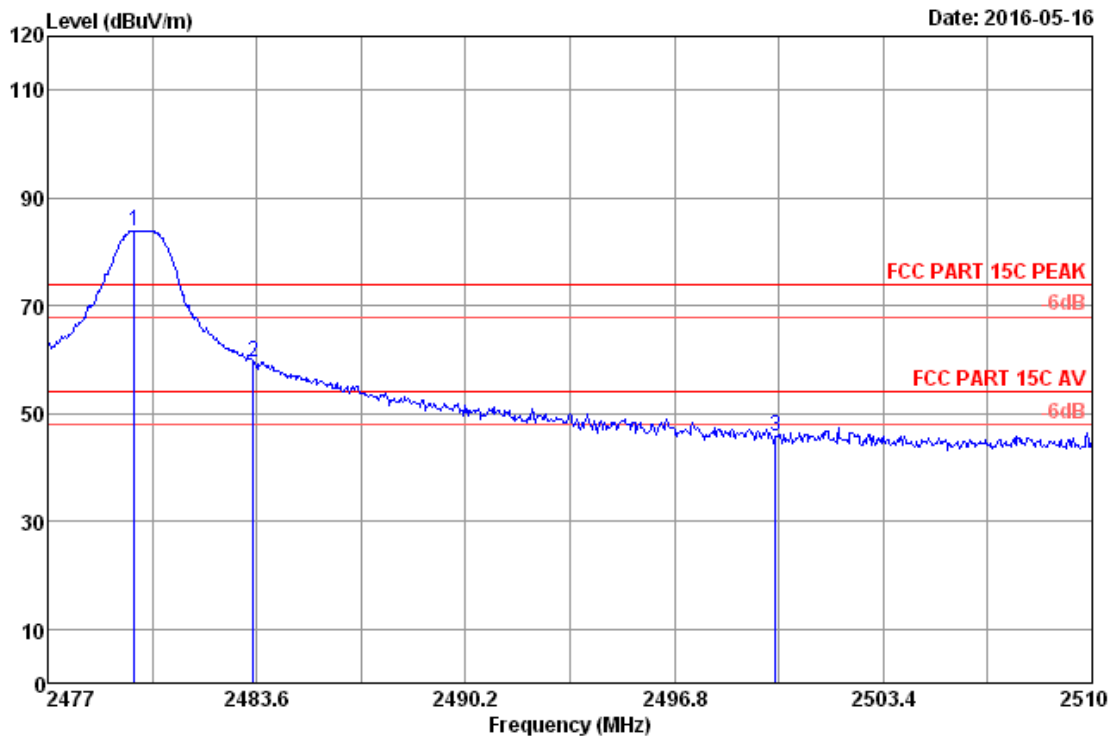

Site no. : RF Chamber
 Dis. / Ant. : 3m 2016 3115(4580)
 Limit : FCC PART 15C PEAK
 Env. / Ins. : 22.6°C/51.2%
 EUT : SHIELD Remote
 Power rating : DC 3V
 Test Mode : GFSK 2480MHz Tx
 M/N : P2930

Data no. : 15
 Ant. pol. : VERTICAL
 Pre : 101.2kPa
 Engineer : Leo-Li

No.	Freq. (MHz)	Ant. Factor (dB/m)	Cable Loss (dB)	Reading (dBUV)	AMP factor (dB)	Emission Level (dBUV/m)	Limits (dBUV/m)	Margin (dB)	Remark
1	2479.74	28.29	8.42	83.62	36.38	83.95	74.00	-9.95	Peak
2	2483.50	28.29	8.42	59.14	36.38	59.47	74.00	14.53	Peak
3	2500.00	28.30	8.44	45.41	36.38	45.77	74.00	28.23	Peak

Remarks: 1. Emission Level= Antenna Factor + Cable Loss + Reading - Amp Factor
 2. The emission levels that are 20dB below the official limit are not reported.

Frequency (MHz)	Original Peak level (dBuv/m)	Mark delta (dB)	Final AV level (dBuv/m)	Limit(dBuv/m)	Conclusion
2483.50	83.95	64.911	19.039	74	Pass

9. POWER SPECTRAL DENSITY TEST

9.1. Test Equipment

Item	Equipment	Manufacturer	Model No.	Serial No.	Last Cal.	Cal. Interval
1.	Spectrum	Agilent	N9030A	MY51380221	Oct.18,15	1Year
2.	Attenuator (20dB)	Agilent	8491B	MY39262165	Apr.23,16	1 Year
3.	RF Cable	Marvelous Microwave Inc	SFL402105FLEX	NO.1	Oct.17,15	1 Year

9.2. Limit

For digitally modulated systems, the power spectral density conducted from the intentional radiator to the antenna shall not be greater than 8dBm in any 3kHz band during any time interval of continuous transmission.

9.3. Test Procedure

1. Connected the EUT’s antenna port to spectrum analyzer device by 20dB attenuator.
2. Set the test frequency as center frequency, Set RBW=3KHz,VBW=10KHz,Span large enough capture the entire frequency, Read out maximum peak level frequency
3. Set the span to 1.5 times of the DTS Bandwidth Detector= Peak; Sweep time= Auto Couple; Trace Mode= Max hold.
4. Allow trace to fully stabilize use the peak marker function to determine the maximum amplitude level within the RBW.

Note: The cable loss and attenuator loss were offset into measure device as an amplitude

9.4. Test Results

EUT: SHIELD Remote		
M/N: P2930		
Test date: 2016-05-06	Pressure: 101.7±1.0 kpa	Humidity: 51.8±3.0%
Tested by: Leo_li	Test site: RF site	Temperature:22.5±0.6

Test Mode	Frequency (MHz)	Power density (dBm/3KHz)	Limit (dBm/3KHz)
GFSK	2402	-13.749	8
	2440	-13.587	8
	2480	-13.781	8

Conclusion : PASS

GFSK

2402MHz



2480MHz



2440MHz



10. ANTENNA REQUIREMENT

10.1. STANDARD APPLICABLE

For intentional device, according to FCC 47 CFR Section 15.203, an intentional radiator shall be designed to ensure that no antenna other than that furnished by the responsible party shall be used with the device. And according to FCC 47 CFR Section 15.247 (b), if transmitting antennas of directional gain greater than 6dBi are used, the power shall be reduced by the amount in dB that the directional gain of the antenna exceeds 6dBi.

10.2. ANTENNA CONNECTED CONSTRUCTION

The antennas used for this product are Monopole antenna that no antenna other than that furnished by the responsible party shall be used with the device, the maximum peak gain of the transmit antenna is -1.8dBi.

11. DEVIATION TO TEST SPECIFICATIONS

[NONE]