

# FCC Radio Test Report

## FCC ID: VOB-P2897

This report concerns (check one):  Original Grant  Class I Change  Class II Change

**Project No.** : 1602C038E  
**Equipment** : SHIELD Android TV Game Console  
**Test Model** : P2897  
**Series Model** : N/A  
**Applicant** : NVIDIA Corporation  
**Address** : 2788 San Tomas Expressway, Santa Clara, California  
95051, United States

**Date of Receipt** : Feb. 14, 2016  
Oct. 31, 2017  
Oct. 26, 2018  
**Date of Test** : Feb. 14, 2016 ~ Jul. 11, 2016  
Nov. 21, 2017 ~ Apr. 09, 2018  
Oct. 30, 2018 ~ Mar. 18, 2019  
**Issued Date** : Jun. 11, 2019  
**Tested by** : BTL Inc.

**Testing Engineer** : Kai Xu  
(Kai Xu)

**Technical Manager** : Steven Lu  
(Steven Lu)

**Authorized Signatory** : Ethan Ma  
(Ethan Ma)

# **B T L I N C .**

No.3, Jinshagang 1st Road, Shixia, Dalang Town, Dongguan,  
Guangdong, China.

TEL: +86-769-8318-3000 FAX: +86-769-8319-6000



Certificate #5123.02

**Declaration**

**BTL** represents to the client that testing is done in accordance with standard procedures as applicable and that test instruments used has been calibrated with standards traceable to international standard(s) and/or national standard(s).

**BTL's** reports apply only to the specific samples tested under conditions. It is manufacture's responsibility to ensure that additional production units of this model are manufactured with the identical electrical and mechanical components. **BTL** shall have no liability for any declarations, inferences or generalizations drawn by the client or others from **BTL** issued reports.

The report must not be used by the client to claim product certification, approval, or endorsement by NVLAP, NIST, A2LA, or any agency of the U.S. Government.

This report is the confidential property of the client. As a mutual protection to the clients, the public and ourselves, the test report shall not be reproduced, except in full, without our written approval.

**BTL's** laboratory quality assurance procedures are in compliance with the **ISO/IEC 17025** requirements, and accredited by the conformity assessment authorities listed in this test report.

**BTL** is not responsible for the sampling stage, so the results only apply to the sample as received.

The information, data and test plan are provided by manufacturer which may affect the validity of results, so it is manufacturer's responsibility to ensure that the apparatus meets the essential requirements of applied standards and in all the possible configurations as representative of its intended use.

**Limitation**

For the use of the authority's logo is limited unless the Test Standard(s)/Scope(s)/Item(s) mentioned in this test report is (are) included in the conformity assessment authorities acceptance respective.

Please note that the measurement uncertainty is provided for informational purpose only and are not use in determining the Pass/Fail results.

**Table of Contents**

**Page**

<b>REPORT ISSUED HISTORY</b>	<b>5</b>
<b>1 . GENERAL SUMMARY</b>	<b>6</b>
<b>2 . SUMMARY OF TEST RESULTS</b>	<b>7</b>
2.1 TEST FACILITY	8
2.2 MEASUREMENT UNCERTAINTY	8
<b>3 . GENERAL INFORMATION</b>	<b>9</b>
3.1 GENERAL DESCRIPTION OF EUT	9
3.2 DESCRIPTION OF TEST MODES	13
3.3 BLOCK DIAGRAM SHOWING THE CONFIGURATION OF SYSTEM TESTED	15
3.4 DESCRIPTION OF SUPPORT UNITS	15
<b>4 . EMC EMISSION TEST</b>	<b>16</b>
4.1 CONDUCTED EMISSION MEASUREMENT	16
4.1.1 POWER LINE CONDUCTED EMISSION	16
4.1.2 TEST PROCEDURE	16
4.1.3 DEVIATION FROM TEST STANDARD	16
4.1.4 TEST SETUP	17
4.1.5 EUT OPERATING CONDITIONS	17
4.1.6 EUT TEST CONDITIONS	17
4.1.7 TEST RESULTS	17
4.2 RADIATED EMISSION MEASUREMENT	18
4.2.1 RADIATED EMISSION LIMITS	18
4.2.2 TEST PROCEDURE	19
4.2.3 DEVIATION FROM TEST STANDARD	19
4.2.4 TEST SETUP	20
4.2.5 EUT OPERATING CONDITIONS	21
4.2.6 EUT TEST CONDITIONS	21
4.2.7 TEST RESULTS (9K TO 30MHz)	21
4.2.8 TEST RESULTS (BETWEEN 30 TO 1000 MHz)	21
4.2.9 TEST RESULTS (ABOVE 1000 MHz)	21
<b>5 . 26dB SPECTRUM BANDWIDTH</b>	<b>22</b>
5.1 APPLIED PROCEDURES / LIMIT	22
5.1.1 TEST PROCEDURE	22
5.1.2 DEVIATION FROM STANDARD	23
5.1.3 TEST SETUP	23
5.1.4 EUT OPERATION CONDITIONS	23
5.1.5 EUT TEST CONDITIONS	23
5.1.6 TEST RESULTS	23
<b>6 . MAXIMUM OUTPUT POWER</b>	<b>24</b>

Table of Contents	Page
<b>6.1 APPLIED PROCEDURES / LIMIT</b>	<b>24</b>
6.1.1 TEST PROCEDURE	24
6.1.2 DEVIATION FROM STANDARD	25
6.1.3 TEST SETUP	25
6.1.4 EUT OPERATION CONDITIONS	25
6.1.5 EUT TEST CONDITIONS	25
6.1.6 TEST RESULTS	25
<b>7 . POWER SPECTRAL DENSITY TEST</b>	<b>26</b>
7.1 APPLIED PROCEDURES / LIMIT	26
8.1.1 TEST PROCEDURE	26
7.1.1 DEVIATION FROM STANDARD	27
7.1.2 TEST SETUP	27
7.1.3 EUT OPERATION CONDITIONS	27
7.1.4 EUT TEST CONDITIONS	27
7.1.5 TEST RESULTS	27
<b>8 . FREQUENCY STABILITY MEASUREMENT</b>	<b>28</b>
8.1 APPLIED PROCEDURES / LIMIT	28
8.1.1 TEST PROCEDURE	28
8.1.2 DEVIATION FROM STANDARD	28
8.1.3 TEST SETUP	29
8.1.4 EUT OPERATION CONDITIONS	29
8.1.5 EUT TEST CONDITIONS	29
8.1.6 TEST RESULTS	29
<b>9 . MEASUREMENT INSTRUMENTS LIST</b>	<b>30</b>
<b>10 . EUT TEST PHOTOS</b>	<b>32</b>
<b>APPENDIX A - CONDUCTED EMISSION</b>	<b>36</b>
<b>APPENDIX B - RADIATED EMISSION (9KHZ TO 30MHZ)</b>	<b>39</b>
<b>APPENDIX C - RADIATED EMISSION (30MHZ TO 1000MHZ)</b>	<b>44</b>
<b>APPENDIX D - RADIATED EMISSION (ABOVE 1000MHZ)</b>	<b>93</b>
<b>APPENDIX E - BANDWIDTH</b>	<b>384</b>
<b>APPENDIX F - MAXIMUM OUTPUT POWER</b>	<b>438</b>
<b>APPENDIX G - POWER SPECTRAL DENSITY</b>	<b>463</b>
<b>APPENDIX H - FREQUENCY STABILITY</b>	<b>574</b>

### REPORT ISSUED HISTORY

Report Version	Description	Issued Date
R00	<p>Original Issue. This is a supplementary report to the original test report (BTL-FCCP-4-1602C038D). Based on the original report, this report has below changed:</p> <ol style="list-style-type: none"> <li>1. The applicant and manufacturer address are changed.</li> <li>2. RF chip changed from BCM4354 to CYW4356.</li> <li>3. The CYW4356 is based on the BCM4354 and is pin-to-pin compatible. Both chipset possess the same Wi-Fi RF features and performance.</li> <li>4. The CYW4356 removed the FM section, which was not used in originally released product.</li> <li>5. The CYW4356 is capable of supporting Bluetooth v5.0, however none of Bluetooth 5.0 features have been incorporated into this product update.</li> </ol> <p>So the Maximum Output Power and Power Spectral Density test items have been retested and recorded in this report. Other are kept same.</p>	Jun. 11, 2019

## 1. GENERAL SUMMARY

Equipment : SHIELD Android TV Game Console  
Brand Name : NVIDIA  
Test Model : P2897  
Series Model : N/A  
Applicant : NVIDIA Corporation  
Manufacturer : NVIDIA Corporation  
Address : 2788 San Tomas Expressway, Santa Clara, California 95051, United States  
Date of Test : Feb. 14, 2016 ~ Jul. 11, 2016  
Nov. 21, 2017 ~ Apr. 09, 2018  
Oct. 30, 2018 ~ Mar. 18, 2019  
Test Sample : Engineering Sample No.: D181009693  
Standard(s) : FCC Part15, Subpart E(15.407) / ANSI C63.10-2013

The above equipment has been tested and found compliance with the requirement of the relative standards by BTL Inc.

The test data, data evaluation, and equipment configuration contained in our test report (Ref No. BTL-FCCP-4-1602C038E) were obtained utilizing the test procedures, test instruments, test sites that has been accredited by the Authority of A2LA according to the ISO/IEC 17025 quality assessment standard and technical standard(s).

**Test results included in this report are only for the RLAN UNII-1, UNII-2A, UNII-2C, UNII-3 part.**

## 2. SUMMARY OF TEST RESULTS

Test procedures according to the technical standard(s):

FCC Part15, Subpart E(15.407)			
Standard(s) Section	Test Item	Judgment	Remark
15.207 15.407(b)	AC Power Line Conducted Emissions	PASS	
15.407(a) 15.407(e)	26dB Spectrum Bandwidth	PASS	
15.407(a)	Maximum Output Power	PASS	
15.407(a)	Power Spectral Density	PASS	
15.407(b) 15.205(a) 15.209(a)	Radiated Emissions	PASS	
15.407(g)	Frequency Stability	PASS	
15.203	Antenna Requirements	PASS	
15.407(c)	Automatically Discontinue Transmission	PASS	NOTE (2)

**NOTE:**

- (1) " N/A" denotes test is not applicable in this test report.
- (2) During no any information transmission, the EUT can automatically discontinue transmission and become standby mode for power saving. the EUT can detect the controlling signal of ACK message transmitting from remote device and verify whether it shall resend or discontinue transmission.
- (3) For UNII-1 this device was functioned as a  
 Access point device     Client device

## 2.1 TEST FACILITY

The test facilities used to collect the test data in this report is at the location of No.3,Jinshagang 1st Road, Shixia, Dalang Town, Dongguan, Guangdong, China.

BTL's Test Firm Registration Number for FCC: 357015

BTL's Designation Number for FCC: CN1240

## 2.2 MEASUREMENT UNCERTAINTY

The measurement uncertainty figures shall be calculated according the methods described in the ETSI TR 100 028 and shall correspond to an expansion factor (coverage factor)  $k=1.96$  or  $k=2$ (which provide confidence levels of respectively 90% and 95.45% in the case where the distributions characterizing the actual measurement uncertainties are normal (Gaussian)). Measurement Uncertainty for a Level of Confidence of 95 %,  $U=2 \times U_c(y)$ .

The BTL measurement uncertainty as below table:

### A. Conducted Measurement:

Test Site	Method	Measurement Frequency Range	U, (dB)
DG-C02	CISPR	150 KHz ~ 30MHz	2.32

### B. Radiated Measurement:

Test Site	Method	Measurement Frequency Range	Ant. H / V	U, (dB)
DG-CB03	CISPR	9kHz~30MHz	V	3.79
		9kHz~30MHz	H	3.57
		30MHz ~ 200MHz	V	3.82
		30MHz ~ 200MHz	H	3.60
		200MHz ~ 1,000MHz	V	3.86
		200MHz ~ 1,000MHz	H	3.94
		1GHz~18GHz	V	3.12
		1GHz~18GHz	H	3.68
		18GHz~40GHz	V	4.15
		18GHz~40GHz	H	4.14

Note: Unless specifically mentioned, the uncertainty of measurement has not been taken into account to declare the compliance or non-compliance to the specification.



### 3. GENERAL INFORMATION

#### 3.1 GENERAL DESCRIPTION OF EUT

Equipment	SHIELD Android TV Game Console	
Brand Name	NVIDIA	
Test Model	P2897	
Series Model	N/A	
Model Difference(s)	N/A	
Product Description	Operation Frequency	UNII-1: 5150 MHz~5250 MHz UNII-2A: 5250 MHz~5350 MHz UNII-2C: 5470 MHz~5725 MHz UNII-3: 5725 MHz~5850 MHz
	Modulation Type	OFDM
	Bit Rate of Transmitter	802.11a: 54/48/36/24/18/12/8/6Mbps 802.11n: up to 300Mbps 802.11ac: up to 867Mbps
Maximum Output Power	Output Power (Max.)for UNII-1	802.11a: 20.00dBm 802.11n (20M): 18.58dBm 802.11n (40M): 20.42dBm 802.11ac (20M): 18.44dBm 802.11ac (40M): 20.69dBm 802.11ac (80M): 11.64dBm
	Output Power (Max.)for UNII-2A	802.11a: 19.47dBm 802.11n (20M): 18.27dBm 802.11n (40M): 19.45dBm 802.11ac (20M): 18.16dBm 802.11ac (40M): 19.32dBm 802.11ac (80M): 13.04dBm
	Output Power (Max.)for UNII-2C	802.11a: 19.52dBm 802.11n (20M): 16.89dBm 802.11n (40M): 19.15dBm 802.11ac (20M): 16.72dBm 802.11ac (40M): 18.67dBm 802.11ac (80M): 17.99dBm
	Output Power (Max.)for UNII-3	802.11a: 19.95dBm 802.11n (20M): 21.71dBm 802.11n (40M): 21.91dBm 802.11ac (20M): 21.77dBm 802.11ac (40M): 21.81dBm 802.11ac (80M): 16.83dBm
Power Source	DC Voltage supplied from adapter. Manufacturer: FSP GROUP INC. Model: SPA040A19W2	
Power Rating	Adapter: Input: 100-240V~,1.2A,50-60Hz Output: 19.0V==2.1A EUT: Input: 19Vdc, 2.1A	

**Note:**

1. For a more detailed features description, please refer to the manufacturer's specifications or the user's manual.

2. Channel List:

802.11a 802.11n 20MHz 802.11ac 20MHz		802.11n 40MHz 802.11ac 40MHz		802.11ac 80MHz	
UNII-1		UNII-1		UNII-1	
Channel	Frequency (MHz)	Channel	Frequency (MHz)	Channel	Frequency (MHz)
36	5180	38	5190	42	5210
40	5200	46	5230		
44	5220				
48	5240				

802.11a 802.11n 20MHz 802.11ac 20MHz		802.11n 40MHz 802.11ac 40MHz		802.11ac 80MHz	
UNII-2A		UNII-2A		UNII-2A	
Channel	Frequency (MHz)	Channel	Frequency (MHz)	Channel	Frequency (MHz)
52	5260	54	5270	58	5290
56	5280	62	5310		
60	5300				
64	5320				

802.11a 802.11n 20MHz 802.11ac 20MHz		802.11n 40MHz 802.11ac 40MHz		802.11ac 80MHz	
UNII-2C		UNII-2C		UNII-2C	
Channel	Frequency (MHz)	Channel	Frequency (MHz)	Channel	Frequency (MHz)
100	5500	102	5510	106	5530
104	5520	110	5550	122	5610
108	5540	118	5590		
112	5560	126	5630		
116	5580	134	5670		
120	5600				
124	5620				
128	5640				
132	5660				
136	5680				
140	5700				

802.11a 802.11n 20MHz 802.11ac 20MHz		802.11n 40MHz 802.11ac 40MHz		802.11ac 80MHz	
UNII-3		UNII-3		UNII-3	
Channel	Frequency (MHz)	Channel	Frequency (MHz)	Channel	Frequency (MHz)
149	5745	151	5755	155	5775
153	5765	159	5795		
157	5785				
161	5805				
165	5825				

### 3. Antenna Specification:

Ant.	Brand/Mfr.	Model Name	Antenna Type	Connector	Gain (dBi)	Note
1	NVIDIA Corporation	N/A	Monopole Antenna	IPEX	4.50	UNII-1
2	NVIDIA Corporation	N/A	Monopole Antenna	N/A	4.43	UNII-1

Ant.	Brand/Mfr.	Model Name	Antenna Type	Connector	Gain (dBi)	Note
1	NVIDIA Corporation	N/A	Monopole Antenna	IPEX	4.31	UNII-2A
2	NVIDIA Corporation	N/A	Monopole Antenna	N/A	4.43	UNII-2A

Ant.	Brand/Mfr.	P/N	Antenna Type	Connector	Gain (dBi)	Note
1	NVIDIA Corporation	N/A	Monopole Antenna	IPEX	4.92	UNII-2C
2	NVIDIA Corporation	N/A	Monopole Antenna	N/A	6.57	UNII-2C

Ant.	Brand/Mfr.	P/N	Antenna Type	Connector	Gain (dBi)	Note
1	NVIDIA Corporation	N/A	Monopole Antenna	IPEX	5.23	UNII-3
2	NVIDIA Corporation	N/A	Monopole Antenna	N/A	6.75	UNII-3

**Note:**

- The EUT incorporates a MIMO function. Physically, the EUT provides two completed transmitters and receivers (2T2R). all transmit signals are correlated, then,
- Direction gain =  $10 \log[(10^{G1/20} + 10^{G2/20})^2/N]$ , that are  
 UNII-1 Directional gain =  $10 \log[(10^{4.50/20} + 10^{4.43/20})^2/2] = 7.49 \text{ dBi}$   
 UNII-2A Directional gain =  $10 \log[(10^{4.31/20} + 10^{4.43/20})^2/2] = 7.39 \text{ dBi}$   
 UNII-2C Directional gain =  $10 \log[(10^{4.92/20} + 10^{6.57/20})^2/2] = 8.80 \text{ dBi}$   
 UNII-3 Directional gain =  $10 \log[(10^{5.23/20} + 10^{6.75/20})^2/2] = 9.05 \text{ dBi}$

The UNII-1 Output Power limit is  $24 - 7.49 + 6 = 22.51 \text{ dBm}$   
 The UNII-2A Output Power limit is  $24 - 7.39 + 6 = 22.61 \text{ dBm}$   
 The UNII-2C Output Power limit is  $24 - 8.80 + 6 = 21.20 \text{ dBm}$   
 The UNII-3 Output Power limit is  $30 - 9.05 + 6 = 26.95 \text{ dBm}$

The UNII-1 PSD limit is  $11 - 7.49 + 6 = 9.51 \text{ dBm/MHz}$   
 The UNII-2A PSD limit is  $11 - 7.39 + 6 = 9.61 \text{ dBm/MHz}$   
 The UNII-2C PSD limit is  $11 - 8.80 + 6 = 8.20 \text{ dBm/MHz}$   
 The UNII-3 PSD limit is  $30 - 9.05 + 6 = 26.95 \text{ dBm/500kHz}$ .

4.

Operating Mode	TX Mode	1TX	2TX
802.11a		V (ANT 1 or ANT 2)	-
802.11n (20MHz)		-	V (ANT 1+ANT 2)
802.11n (40MHz)		-	V (ANT 1+ANT 2)
802.11ac (20MHz)		-	V (ANT 1+ANT 2)
802.11ac (40MHz)		-	V (ANT 1+ANT 2)
802.11ac (80MHz)		-	V (ANT 1+ANT 2)

### 3.2 DESCRIPTION OF TEST MODES

To investigate the maximum EMI emission characteristics generates from EUT, the test system was pre-scanning tested base on the consideration of following EUT operation mode or test configuration mode which possible have effect on EMI emission level. Each of these EUT operation mode(s) or test configuration mode(s) mentioned above was evaluated respectively.

Pretest Mode	Description
Mode 1	TX A Mode / CH36, CH40, CH48 (UNII-1)
Mode 2	TX N20 Mode / CH36, CH40, CH48 (UNII-1)
Mode 3	TX N40 Mode / CH38, CH46 (UNII-1)
Mode 4	TX AC20 Mode / CH36, CH40, CH48 (UNII-1)
Mode 5	TX AC40 Mode / CH38, CH46 (UNII-1)
Mode 6	TX AC80 Mode / CH42 (UNII-1)
Mode 7	TX A Mode / CH52, CH60, CH64 (UNII-2A)
Mode 8	TX N20 Mode / CH52, CH60, CH64 (UNII-2A)
Mode 9	TX N40 Mode / CH54, CH62 (UNII-2A)
Mode 10	TX AC20 Mode / CH52, CH60, CH64 (UNII-2A)
Mode 11	TX AC40 Mode / CH54, CH62 (UNII-2A)
Mode 12	TX AC80 Mode / CH58 (UNII-2A)
Mode 13	TX A Mode / CH100, CH116, CH140 (UNII-2C)
Mode 14	TX N20 Mode / CH100, CH116, CH140 (UNII-2C)
Mode 15	TX N40 Mode / CH102, CH110, CH134 (UNII-2C)
Mode 16	TX AC20 Mode / CH100, CH116, CH140 (UNII-2C)
Mode 17	TX AC40 Mode / CH102, CH110, CH134 (UNII-2C)
Mode 18	TX AC80 Mode / CH106, CH122 (UNII-2C)
Mode 19	TX A Mode / CH149,CH157,CH165 (UNII-3)
Mode 20	TX N20 Mode / CH149,CH157,CH165 (UNII-3)
Mode 21	TX N40 Mode / CH151,CH159 (UNII-3)
Mode 22	TX AC20 Mode / CH149,CH157,CH165 (UNII-3)
Mode 23	TX AC40 Mode / CH151,CH159 (UNII-3)
Mode 24	TX AC80 Mode / CH155 (UNII-3)
Mode 25	TX Mode

The EUT system operated these modes were found to be the worst case during the pre-scanning test as following:

For Conducted Test	
Final Test Mode	Description
Mode 25	TX Mode

For Radiated Test	
Final Test Mode	Description
Mode 1	TX A Mode / CH36, CH40, CH48 (UNII-1)
Mode 2	TX N20 Mode / CH36, CH40, CH48 (UNII-1)
Mode 3	TX N40 Mode / CH38, CH46 (UNII-1)
Mode 4	TX AC20 Mode / CH36, CH40, CH48 (UNII-1)
Mode 5	TX AC40 Mode / CH38, CH46 (UNII-1)
Mode 6	TX AC80 Mode / CH42 (UNII-1)
Mode 7	TX A Mode / CH52, CH60, CH64 (UNII-2A)
Mode 8	TX N20 Mode / CH52, CH60, CH64 (UNII-2A)
Mode 9	TX N40 Mode / CH54, CH62 (UNII-2A)
Mode 10	TX AC20 Mode / CH52, CH60, CH64 (UNII-2A)
Mode 11	TX AC40 Mode / CH54, CH62 (UNII-2A)
Mode 12	TX AC80 Mode / CH58 (UNII-2A)
Mode 13	TX A Mode / CH100, CH116, CH140 (UNII-2C)
Mode 14	TX N20 Mode / CH100, CH116, CH140 (UNII-2C)
Mode 15	TX N40 Mode / CH102, CH110, CH134 (UNII-2C)
Mode 16	TX AC20 Mode / CH100, CH116, CH140 (UNII-2C)
Mode 17	TX AC40 Mode / CH102, CH110, CH134 (UNII-2C)
Mode 18	TX AC80 Mode / CH106, CH122 (UNII-2C)
Mode 19	TX A Mode / CH149,CH157,CH165 (UNII-3)
Mode 20	TX N20 Mode / CH149,CH157,CH165 (UNII-3)
Mode 21	TX N40 Mode / CH151,CH159 (UNII-3)
Mode 22	TX AC20 Mode / CH149,CH157,CH165 (UNII-3)
Mode 23	TX AC40 Mode / CH151,CH159 (UNII-3)
Mode 24	TX AC80 Mode / CH155 (UNII-3)

**Note:**

(1) For radiated below 1GHz test, the 802.11a mode is found to be the worst case and recorded.

**3.3 BLOCK DIAGRAM SHOWING THE CONFIGURATION OF SYSTEM TESTED**

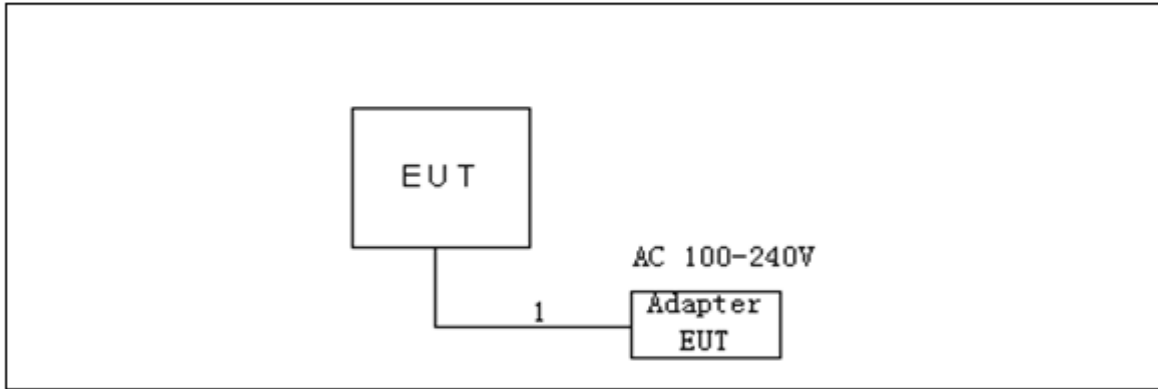

**3.4 DESCRIPTION OF SUPPORT UNITS**

The EUT has been tested as an independent unit together with other necessary accessories or support units. The following support units or accessories were used to form a representative test configuration during the tests.

Item	Equipment	Mfr/Brand	Model/Type No.	Series No.
-	-	-	-	-

Item	Shielded Type	Ferrite Core	Length	Note
1	NO	NO	1.8m	AC Cable

## 4. EMC EMISSION TEST

### 4.1 CONDUCTED EMISSION MEASUREMENT

#### 4.1.1 POWER LINE CONDUCTED EMISSION (Frequency Range 150kHz-30MHz)

Frequency (MHz)	Limit (dB $\mu$ V)	
	Quasi-peak	Average
0.15 - 0.5	66 to 56*	56 - 46*
0.50 - 5.0	56	46
5.0 - 30.0	60	50

Note:

- (1) The tighter limit applies at the band edges.
- (2) The limit of " \* " marked band means the limitation decreases linearly with the logarithm of the frequency in the range.

#### 4.1.2 TEST PROCEDURE

- a. The EUT was placed 0.8 meters from the horizontal ground plane with EUT being connected to the power mains through a line impedance stabilization network (LISN). All other support equipments powered from additional LISN(s). The LISN provide 50 Ohm/ 50uH of coupling impedance for the measuring instrument.
- b. Interconnecting cables that hang closer than 40 cm to the ground plane shall be folded back and forth in the center forming a bundle 30 to 40 cm long.
- c. I/O cables that are not connected to a peripheral shall be bundled in the center. The end of the cable may be terminated, if required, using the correct terminating impedance. The overall length shall not exceed 1 m.
- d. LISN at least 80 cm from nearest part of EUT chassis.
- e. For the actual test configuration, please refer to the related Item –EUT Test Photos.

#### 4.1.3 DEVIATION FROM TEST STANDARD

No deviation



#### 4.1.4 TEST SETUP

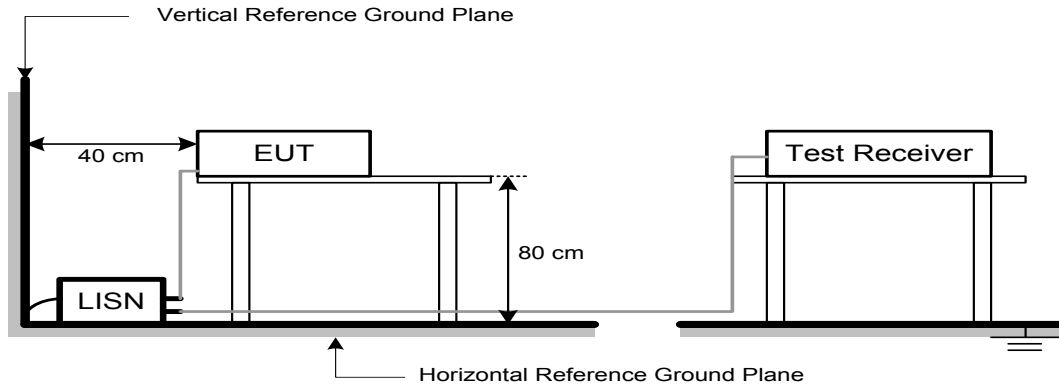

#### 4.1.5 EUT OPERATING CONDITIONS

The EUT was configured for testing in a typical fashion (as a customer would normally use it). The EUT has been programmed to continuously transmit during test. This operating condition was tested and used to collect the included data.

The EUT was programmed to be in continuously transmitting/TX mode.

#### 4.1.6 EUT TEST CONDITIONS

Temperature: 25°C    Relative Humidity: 53%    Test Voltage: AC 120V/60Hz

#### 4.1.7 TEST RESULTS

Please refer to the Appendix A.

Remark:

- (1) All readings are QP Mode value unless otherwise stated AVG in column of『Note』. If the QP Mode Measured value compliance with the QP Limits and lower than AVG Limits, the EUT shall be deemed to meet both QP & AVG Limits and then only QP Mode was measured, but AVG Mode didn't perform. In this case, a “ \* ” marked in AVG Mode column of Interference Voltage Measured.
- (2) Measuring frequency range from 150kHz to 30MHz.

## 4.2 RADIATED EMISSION MEASUREMENT

### 4.2.1 RADIATED EMISSION LIMITS

In case the emission fall within the restricted band specified on 15.205(a), then the 15.209(a) limit in the table below has to be followed.

Frequencies (MHz)	Field Strength (microrvolts/meter)	Measurement Distance (meters)
0.009~0.490	2400/F(kHz)	300
0.490~1.705	24000/F(kHz)	30
1.705~30.0	30	30
30~88	100	3
88~216	150	3
216~960	200	3
Above 960	500	3

Frequencies (MHz)	EIRP Limit (dBm)	Equivalent Field Strength at 3m (dBμV/m)
5150-5250	-27	68.3
5250-5350	-27	68.3
5470-5725	-27	68.3
5725-5850	-27(Note 2)	68.3
	10(Note 2)	105.3
	15.6(Note 2)	110.9
	27(Note 2)	122.3

Note:

1. The following formula is used to convert the equipment isotropic radiated power (eirp) to

field strength:  $E = \frac{1000000\sqrt{30P}}{3} \mu\text{V/m}$ , where P is the eirp (Watts)

2. According to FCC 16-24, All emissions shall be limited to a level of -27 dBm/MHz at 75 MHz or more above or below the band edge increasing linearly to 10 dBm/MHz at 25 MHz above or below the band edge, and from 25MHz above or below the band edge increasing linearly to a level of 15.6 dBm/MHz at 5 MHz above or below the band edge, and from 5 MHz above or below the band edge increasing linearly to a level of 27dBm/MHz at the band edge.

#### 4.2.2 TEST PROCEDURE

- a. The measuring distance of 3 m shall be used for measurements. The EUT was placed on the top of a rotating table 0.8 meter above the ground at a 3 meter semi-anechoic chamber. The table was rotated 360 degrees to determine the position of the highest radiation.(below 1GHz)
- b. The measuring distance of 3 m shall be used for measurements. The EUT was placed on the top of a rotating table 1.5 meter above the ground at a 3 meter semi-anechoic chamber. The table was rotated 360 degrees to determine the position of the highest radiation.(above 1GHz)
- c. The height of the equipment or of the substitution antenna shall be 0.8m or 1.5m; the height of the test antenna shall vary between 1 m to 4 m. Both horizontal and vertical polarizations of the antenna are set to make the measurement.
- d. For each suspected emission, the EUT was arranged to its worst case and then the antenna was tuned to heights find the maximum reading (used Bore sight function).
- e. The receiver system was set to peak and average detect function and specified bandwidth with maximum hold mode when the test frequency is above 1GHz.
- f. The initial step in collecting radiated emission data is a receiver peak detector mode pre-scanning the measurement frequency range. Significant peaks are then marked and then Quasi Peak detector mode re-measured.
- g. All readings are Peak unless otherwise stated QP in column of Note. Peak denotes that the Peak reading compliance with the QP Limits and then QP Mode measurement didn't perform. (below 1GHz)
- h. All readings are Peak Mode value unless otherwise stated AVG in column of Note. If the Peak Mode Measured value compliance with the Peak Limits and lower than AVG Limits, the EUT shall be deemed to meet both Peak & AVG Limits and then only Peak Mode was measured, but AVG Mode didn't perform. (above 1GHz)
- i. For the actual test configuration, please refer to the related Item –EUT Test Photos.

#### 4.2.3 DEVIATION FROM TEST STANDARD

No deviation

### 4.2.4 TEST SETUP

(A) Radiated emissions below 30MHz

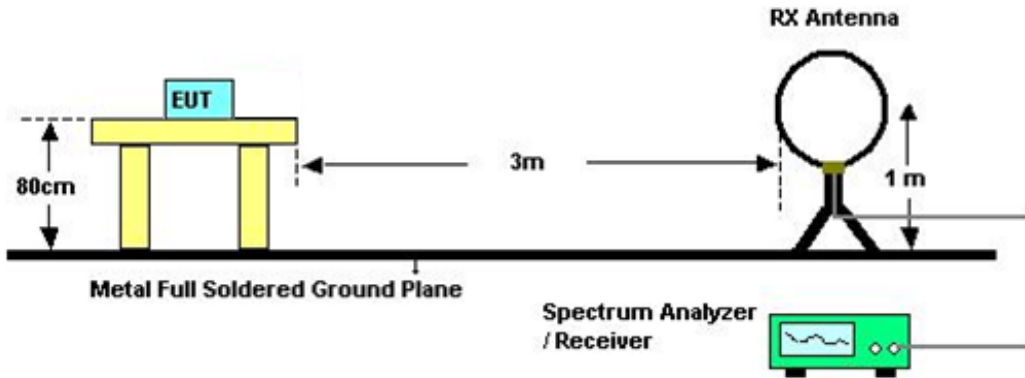

(B) Radiated Emission Test Set-Up Frequency Below 1GHz

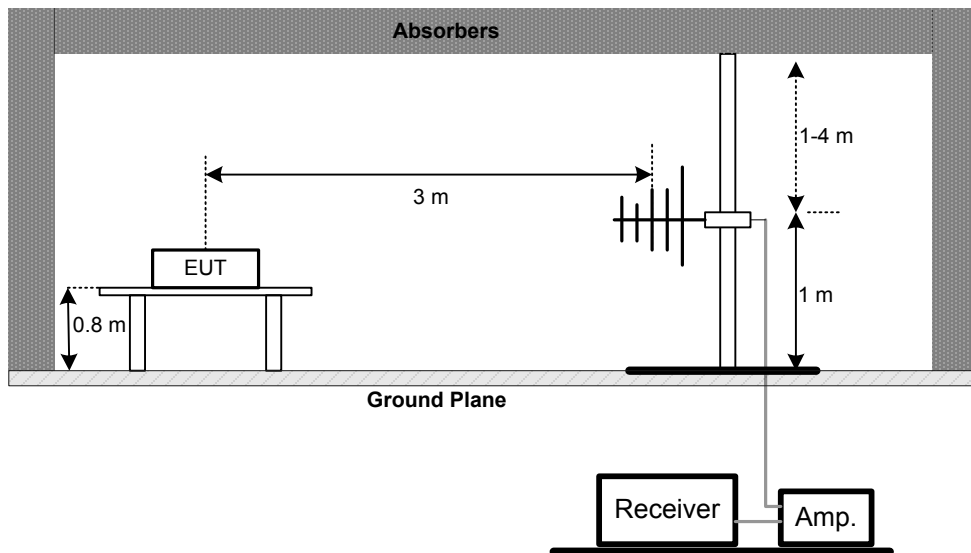

(C) Radiated Emission Test Set-Up Frequency Above 1 GHz

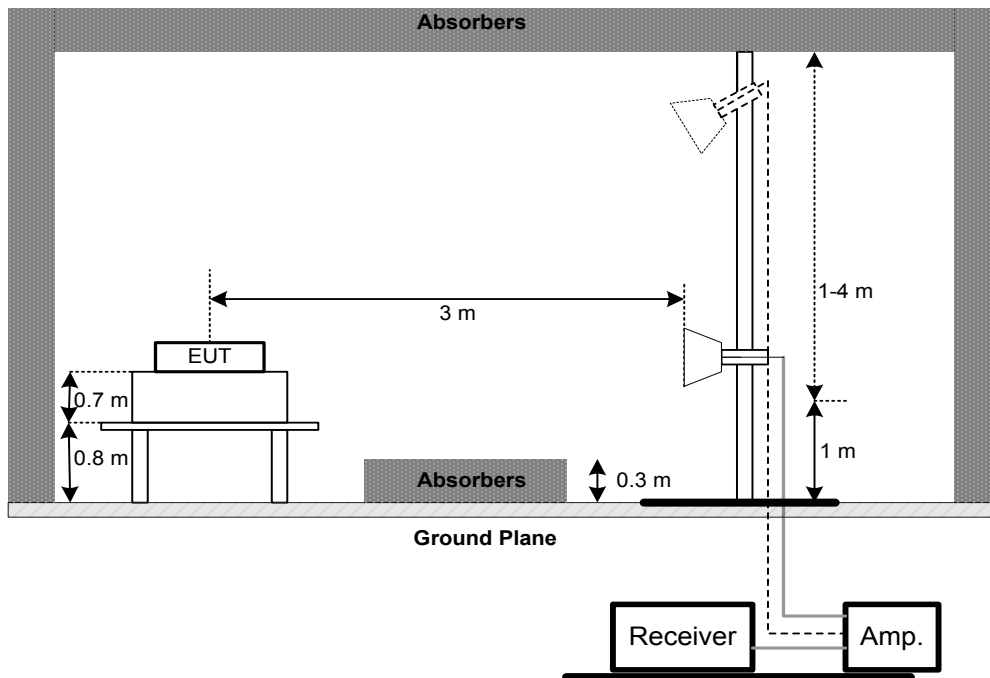

**4.2.5 EUT OPERATING CONDITIONS**

The EUT tested system was configured as the statements of 4.5 unless otherwise a special operating condition is specified in the follows during the testing.

**4.2.6 EUT TEST CONDITIONS**

Temperature: 25°C    Relative Humidity: 60%    Test Voltage: AC 120V/60Hz

**4.2.7 TEST RESULTS (9K TO 30MHz)**

Please refer to the Appendix B

Remark:

- (1) The amplitude of spurious emissions which are attenuated by more than 20 dB below the permissible value has no need to be reported.
- (2) Distance extrapolation factor =  $40 \log(\text{specific distance} / \text{test distance})$  (dB);
- (3) Limit line = specific limits (dBuV) + distance extrapolation factor.

**4.2.8 TEST RESULTS (BETWEEN 30 TO 1000 MHz)**

Please refer to the Appendix C.

**4.2.9 TEST RESULTS (ABOVE 1000 MHz)**

Please refer to the Appendix D.

Remark:

- (1) No limit: This is fundamental signal, the judgment is not applicable. For fundamental signal judgment was referred to Peak output test.

## 5. 26dB SPECTRUM BANDWIDTH

### 5.1 APPLIED PROCEDURES / LIMIT

FCC Part15, Subpart E			
Test Item	Limit	Frequency Range (MHz)	Result
Bandwidth	26 dB Bandwidth	5150-5250	PASS
	26 dB Bandwidth	5250-5350	PASS
	26 dB Bandwidth	5470-5725	PASS
	Minimum 500kHz 6dB Bandwidth	5725-5850	PASS

#### 5.1.1 TEST PROCEDURE

- a. The EUT was directly connected to the spectrum analyzer and antenna output port as show in the block diagram below,
- b. Spectrum Setting:  
For UNII-1, UNII-2A, UNII-2C:

Spectrum Parameter	Setting
Attenuation	Auto
Span Frequency	> 26 dB Bandwidth
RBW	300 kHz (Bandwidth 20 MHz) 1 MHz (Bandwidth 40 MHz and 80 MHz)
VBW	1 MHz (Bandwidth 20 MHz) 3 MHz (Bandwidth 40 MHz and 80 MHz)
Detector	Peak
Trace	Max Hold
Sweep Time	Auto

For UNII-3:

Spectrum Parameter	Setting
Attenuation	Auto
Span Frequency	6 dB Bandwidth
RBW	100 kHz
VBW	300 kHz
Detector	Peak
Trace	Max Hold
Sweep Time	Auto

- c. Measured the spectrum width with power higher than 26dB below carrier

### 5.1.2 DEVIATION FROM STANDARD

No deviation.

### 5.1.3 TEST SETUP



### 5.1.4 EUT OPERATION CONDITIONS

The EUT tested system was configured as the statements of 4.5 unless otherwise a special operating condition is specified in the follows during the testing.

### 5.1.5 EUT TEST CONDITIONS

Temperature: 25°C    Relative Humidity: 60%    Test Voltage: AC 120V/60Hz

### 5.1.6 TEST RESULTS

Please refer to the Appendix E.

## 6. MAXIMUM OUTPUT POWER

### 6.1 APPLIED PROCEDURES / LIMIT

FCC Part15, Subpart E			
Test Item	Limit	Frequency Range (MHz)	Result
Maximum Output Power	AP device: 1 Watt (30 dBm) Client device: 250 mW (24 dBm)	5150-5250	PASS
	250mW (24dBm)	5250-5350	PASS
	250mW (24dBm)	5470-5725	PASS
	1 Watt (30dBm)	5725-5850	PASS

**Note:**

- a. For an outdoor access point operating in the band 5.15-5.25 GHz, the maximum conducted output power over the frequency band of operation shall not exceed 1 W provided the maximum antenna gain does not exceed 6 dBi. In addition, the maximum power spectral density shall not exceed 17 dBm in any 1 megahertz band. If transmitting antennas of directional gain greater than 6 dBi are used, both the maximum conducted output power and the maximum power spectral density shall be reduced by the amount in dB that the directional gain of the antenna exceeds 6 dBi. The maximum e.i.r.p. at any elevation angle above 30 degrees as measured from the horizon must not exceed 125 mW (21 dBm).
- b. For the 5.25-5.35 GHz and 5.47-5.725 GHz bands, the maximum conducted output power over the frequency bands of operation shall not exceed the lesser of 250 mW or 11 dBm + 10log B, where B is the 26dB Bandwidth in megahertz.

#### 6.1.1 TEST PROCEDURE

- a. The EUT was directly connected to the power meter and antenna output port as show in the block diagram below.
- b. Used spectrum analyzer band power measurement function.
- c. Spectrum Setting

Spectrum Parameter	Setting
Attenuation	Auto
Span Frequency	Encompass the entire emissions bandwidth (EBW) of the signal
RBW	= 1 MHz.
VBW	≥ 3 MHz.
Sweep points	≥ 2 x span / RBW
Detector	RMS
Trace	Trace average at least 100 traces in power averaging(rms) mode.
Sweep Time	auto

- d. Test test was performed in accordance with method of FCC KDB 789033 D02 General UNII Test Procedures New Rules v02r01.



### 6.1.2 DEVIATION FROM STANDARD

No deviation.

### 6.1.3 TEST SETUP



### 6.1.4 EUT OPERATION CONDITIONS

The EUT tested system was configured as the statements of 4.5 unless otherwise a special operating condition is specified in the follows during the testing.

### 6.1.5 EUT TEST CONDITIONS

Temperature: 25°C    Relative Humidity: 60%    Test Voltage: AC 120V/60Hz

### 6.1.6 TEST RESULTS

Please refer to the Appendix F.

## 7. POWER SPECTRAL DENSITY TEST

### 7.1 APPLIED PROCEDURES / LIMIT

FCC Part15, Subpart E			
Test Item	Limit	Frequency Range (MHz)	Result
Power Spectral Density	AP device: 17 dBm/MHz Client device: 11 dBm/MHz	5150-5250	PASS
	11dBm/MHz	5250-5350	PASS
	11dBm/MHz	5470-5725	PASS
	30dBm/500kHz	5725-5850	PASS

#### 8.1.1 TEST PROCEDURE

- a. The EUT was directly connected to the spectrum analyzer and antenna output port as show in the block diagram below,
- b. Spectrum Setting

Spectrum Parameter	Setting
Attenuation	Auto
Span Frequency	Encompass the entire emissions bandwidth (EBW) of the signal
RBW	= 1 MHz.
VBW	≥ 3 MHz.
Detector	RMS
Trace average	100 trace
Sweep Time	Auto

Note:

1. For UNII-3, according to KDB publication 789033 D02 General UNII Test Procedures New Rules v02r01, section II.F.5., it is acceptable to set RBW at 1 MHz and VBW at 3 MHz if the spectrum analyzer does not have 500 kHz RBW.
2. The value measured with RBW=1 MHz is to be added with  $10\log(500\text{ kHz}/1\text{ MHz})$  which is -3 dB. For example, if the measured value is +10dBm using RBW=1 MHz (that is +10 dBm/MHz), then the converted value will be +7dBm/500kHz.

### 7.1.1 DEVIATION FROM STANDARD

No deviation.

### 7.1.2 TEST SETUP

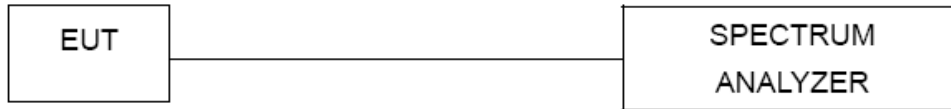

### 7.1.3 EUT OPERATION CONDITIONS

The EUT tested system was configured as the statements of 4.5 unless otherwise a special operating condition is specified in the follows during the testing.

### 7.1.4 EUT TEST CONDITIONS

Temperature: 25°C    Relative Humidity: 60%    Test Voltage: AC 120V/60Hz

### 7.1.5 TEST RESULTS

Please refer to the Appendix H.

## 8. FREQUENCY STABILITY MEASUREMENT

### 8.1 APPLIED PROCEDURES / LIMIT

FCC Part15, Subpart E			
Test Item	Limit	Frequency Range (MHz)	Result
Frequency Stability	Specified in the user's manual	5150-5250	PASS
		5250-5350	PASS
		5470-5725	PASS
		5725-5850	PASS

#### 8.1.1 TEST PROCEDURE

- a. The EUT was directly connected to the spectrum analyzer and antenna output port as show in the block diagram below,
- b. Spectrum Setting:

Spectrum Parameter	Setting
Attenuation	Auto
Span Frequency	Entire absence of modulation emissions bandwidth
RBW	10 kHz
VBW	10 kHz
Sweep Time	Auto

- c. The test extreme voltage is to change the primary supply voltage from 85 to 115 percent of the nominal value.
- d. User manual temperature is 0°C~40°C.

#### 8.1.2 DEVIATION FROM STANDARD

No deviation.

### 8.1.3 TEST SETUP

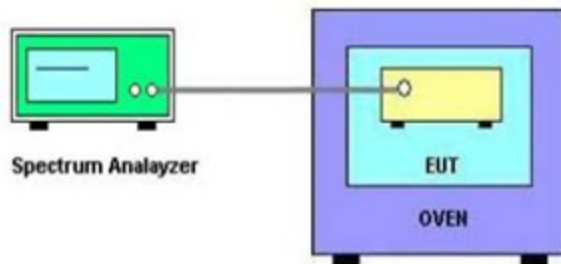

### 8.1.4 EUT OPERATION CONDITIONS

The EUT tested system was configured as the statements of 4.5 unless otherwise a special operating condition is specified in the follows during the testing.

### 8.1.5 EUT TEST CONDITIONS

Temperature: 25°C    Relative Humidity: 55%    Test Voltage: AC 120V/60Hz

### 8.1.6 TEST RESULTS

Please refer to the Appendix I.

## 9. MEASUREMENT INSTRUMENTS LIST

Conducted Emission Measurement					
Item	Kind of Equipment	Manufacturer	Type No.	Serial No.	Calibrated until
1	EMI Test Receiver	R&S	ESCI	100382	Mar. 11, 2019
2	LISN	EMCO	3816/2	52765	Mar. 11, 2019
3	50Ω Terminator	SHX	TF2-3G-A	8122901	Mar. 11, 2019
4	TWO-LINE V-NETWORK	R&S	ENV216	101447	Mar. 11, 2019
5	Measurement Software	Farad	EZ-EMC Ver.NB-03A1-01	N/A	N/A
6	Cable	N/A	RG223	12m	Oct. 19, 2018

Radiated Emission Measurement - Below 1GHz					
Item	Kind of Equipment	Manufacturer	Type No.	Serial No.	Calibrated until
1	Antenna	Schwarbeck	VULB9160	9160-3232	Mar. 11, 2019
2	Amplifier	HP	8447D	2944A09673	Oct. 19, 2018
3	Receiver	Agilent	N9038A	MY52130039	Aug. 20, 2018
4	Cable	emci	LMR-400(30MHz-1 GHz)(8m+5m)	N/A	Jun. 26, 2018
5	Controller	CT	SC100	N/A	N/A
6	Controller	MF	MF-7802	MF780208416	N/A
7	Measurement Software	Farad	EZ-EMC Ver.NB-03A1-01	N/A	N/A
8	Antenna	EM	EM-6876-1	230	Feb. 07, 2019

Radiated Emission Measurement - Above 1GHz					
Item	Kind of Equipment	Manufacturer	Type No.	Serial No.	Calibrated until
1	Double Ridged Guide Antenna	ETS	3115	75789	Mar. 11, 2019
2	Broad-Band Horn Antenna	Schwarzbeck	BBHA 9170	9170319	Jun. 08, 2018
3	Amplifier	Agilent	8449B	3008A02274	Mar. 11, 2019
4	Microwave Pre-amplifier With Adaptor	EMC INSTRUMENT	EMC2654045	980039 & HA01	Mar. 11, 2019
5	Receiver	Agilent	N9038A	MY52130039	Aug. 20, 2018
6	Controller	CT	SC100	N/A	N/A
7	Controller	MF	MF-7802	MF780208416	N/A
8	Cable	emci	EMC104-SM-SM-1 2000(12m)	N/A	Jun. 26, 2018
9	Measurement Software	Farad	EZ-EMC Ver.NB-03A1-01	N/A	N/A

Spectrum Bandwidth Measurement					
Item	Kind of Equipment	Manufacturer	Type No.	Serial No.	Calibrated until
1	Spectrum Analyzer	R&S	FSP40	100185	Aug. 20, 2018

Maximum Output Power Measurement					
Item	Kind of Equipment	Manufacturer	Type No.	Serial No.	Calibrated until
1	Spectrum Analyzer	R&S	FSP40	100185	Aug. 11, 2019

Power Spectral Density Measurement					
Item	Kind of Equipment	Manufacturer	Type No.	Serial No.	Calibrated until
1	Spectrum Analyzer	R&S	FSP40	100185	Aug. 20, 2018

Frequency Stability Measurement					
Item	Kind of Equipment	Manufacturer	Type No.	Serial No.	Calibrated until
1	Spectrum Analyzer	R&S	FSP40	100185	Aug. 20, 2018
2	Precision Oven Tester	Bell	BTH-50C	20170306001	Mar. 11, 2019

Remark: "N/A" denotes no model name, serial no. or calibration specified.  
 All calibration period of equipment list is one year.

## APPENDIX A - CONDUCTED EMISSION



Test Mode: TX MODE

**Line**

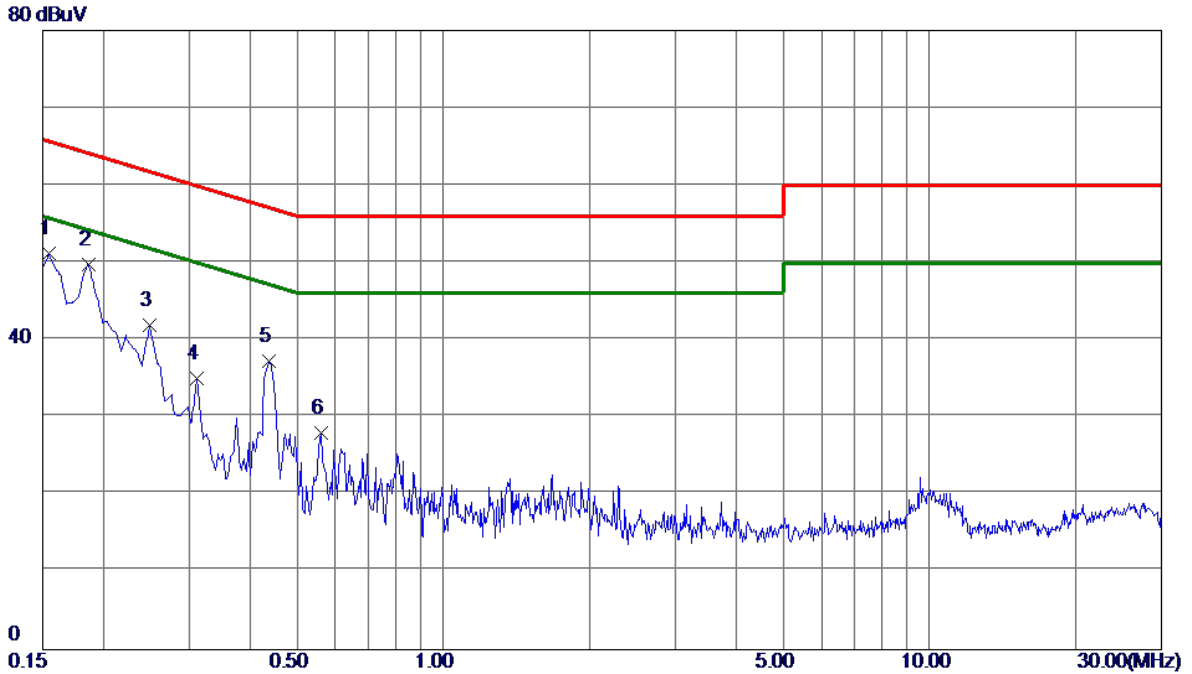

No.	Freq. MHz	Reading Level dBuV	Correct Factor dB	Measure ment dBuV	Limit dBuV	Margin dB	Detector	Comment
1	0.1545	41.48	9.75	51.23	65.75	-14.52	Peak	
2 *	0.1860	40.09	9.73	49.82	64.21	-14.39	Peak	
3	0.2490	32.26	9.72	41.98	61.79	-19.81	Peak	
4	0.3120	25.39	9.72	35.11	59.92	-24.81	Peak	
5	0.4380	27.53	9.75	37.28	57.10	-19.82	Peak	
6	0.5595	18.18	9.76	27.94	56.00	-28.06	Peak	

Note : The test result has included the cable loss.

Test Mode: TX MODE

### Neutral

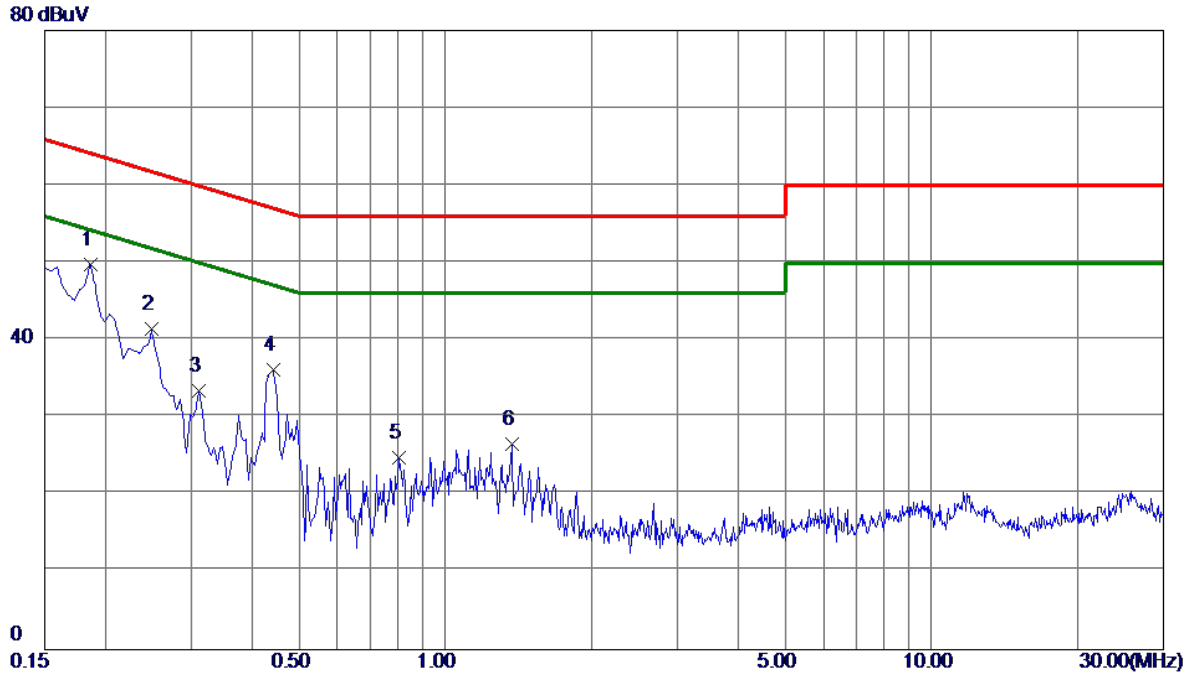

No.	Freq. MHz	Reading Level dBuV	Correct Factor dB	Measure ment dBuV	Limit dBuV	Margin dB	Detector	Comment
1 *	0.1860	40.14	9.65	49.79	64.21	-14.42	Peak	
2	0.2490	31.84	9.63	41.47	61.79	-20.32	Peak	
3	0.3120	23.81	9.64	33.45	59.92	-26.47	Peak	
4	0.4425	26.51	9.65	36.16	57.01	-20.85	Peak	
5	0.8025	15.08	9.66	24.74	56.00	-31.26	Peak	
6	1.3695	16.93	9.69	26.62	56.00	-29.38	Peak	

Note : The test result has included the cable loss.

## APPENDIX B - RADIATED EMISSION (9KHZ TO 30MHZ)

Test Mode: TX Mode

Ant 0°

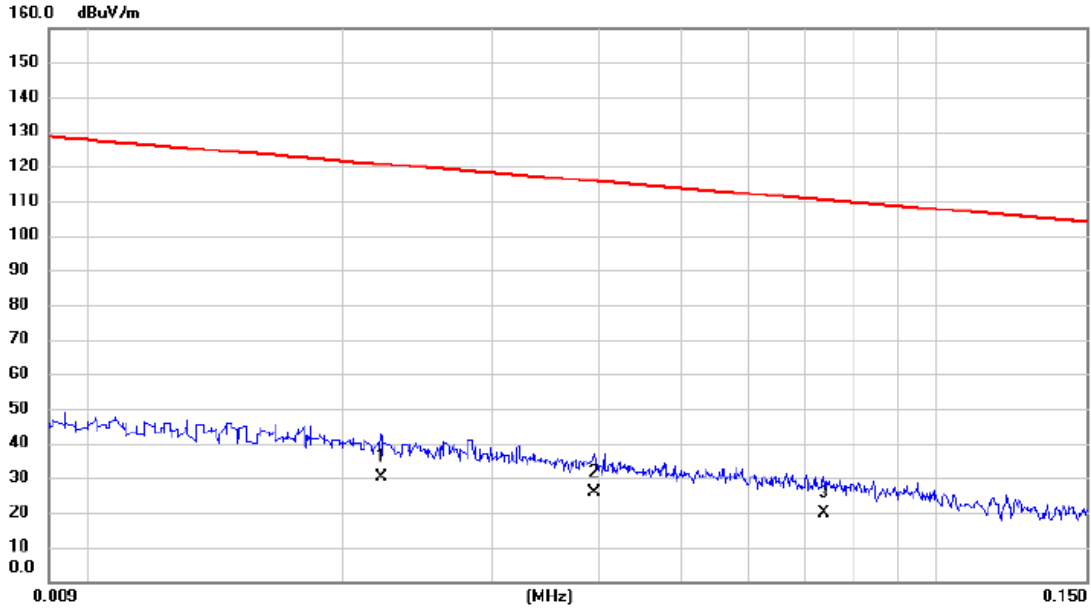

No.	Mk.	Freq. MHz	Reading Level dBuV	Correct Factor dB	Measure- ment dBuV/m	Limit dBuV/m	Margin dB	Detector	Comment
1		0.0222	30.10	0.02	30.12	120.68	-90.56	AVG	
2	*	0.0395	25.60	0.02	25.62	115.67	-90.05	AVG	
3		0.0736	19.60	0.03	19.63	110.27	-90.64	AVG	

Test Mode: TX Mode

Ant 0°

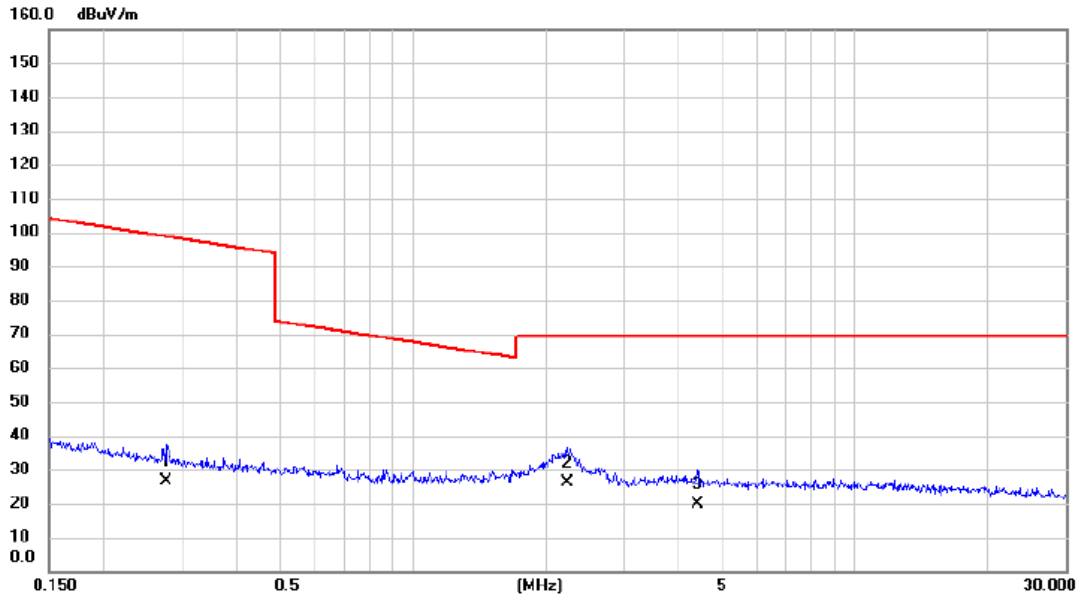

No.	Mk.	Freq. MHz	Reading Level dBuV	Correct Factor dB	Measurement dBuV/m	Limit dBuV/m	Margin dB	Detector	Comment
1		0.2773	26.50	0.06	26.56	98.75	-72.19	AVG	
2	*	2.2367	26.10	0.11	26.21	69.54	-43.33	QP	
3		4.4071	19.60	0.16	19.76	69.54	-49.78	QP	

Test Mode: TX Mode

Ant 90°

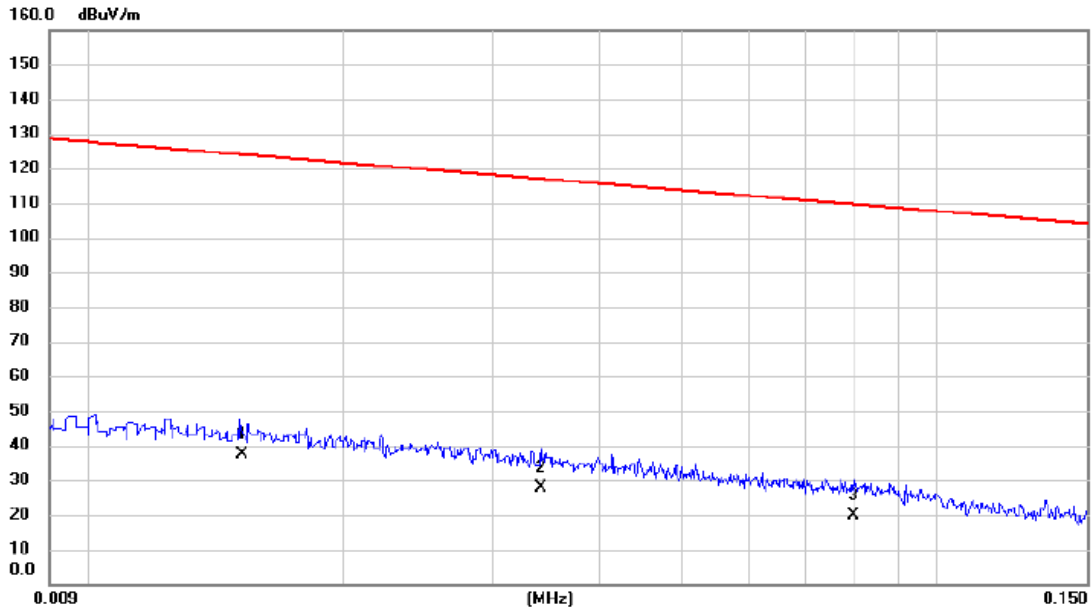

No.	Mk.	Freq. MHz	Reading Level dBuV	Correct Factor dB	Measure- ment dBuV/m	Limit dBuV/m	Margin dB	Detector	Comment
1	*	0.0152	37.50	0.02	37.52	123.97	-86.45	AVG	
2		0.0342	27.90	0.02	27.92	116.92	-89.00	AVG	
3		0.0796	19.60	0.03	19.63	109.59	-89.96	AVG	

Test Mode: TX Mode

Ant 90°

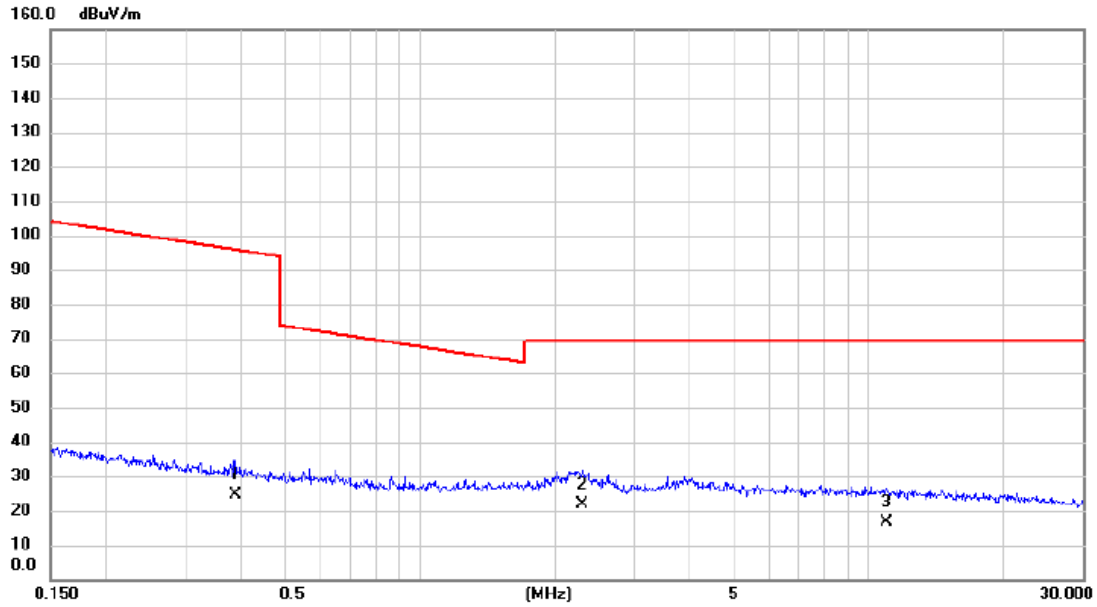

No.	Mk.	Freq. MHz	Reading Level dBuV	Correct Factor dB	Measure- ment dBuV/m	Limit dBuV/m	Margin dB	Detector	Comment
1		0.3871	24.50	0.06	24.56	95.85	-71.29	AVG	
2	*	2.2967	21.50	0.12	21.62	69.54	-47.92	QP	
3		10.9630	16.40	0.26	16.66	69.54	-52.88	QP	

## APPENDIX C - RADIATED EMISSION (30MHZ TO 1000MHZ)



Test Mode: UNII-1/TX A Mode 5180MHz\_ANT1

Vertical

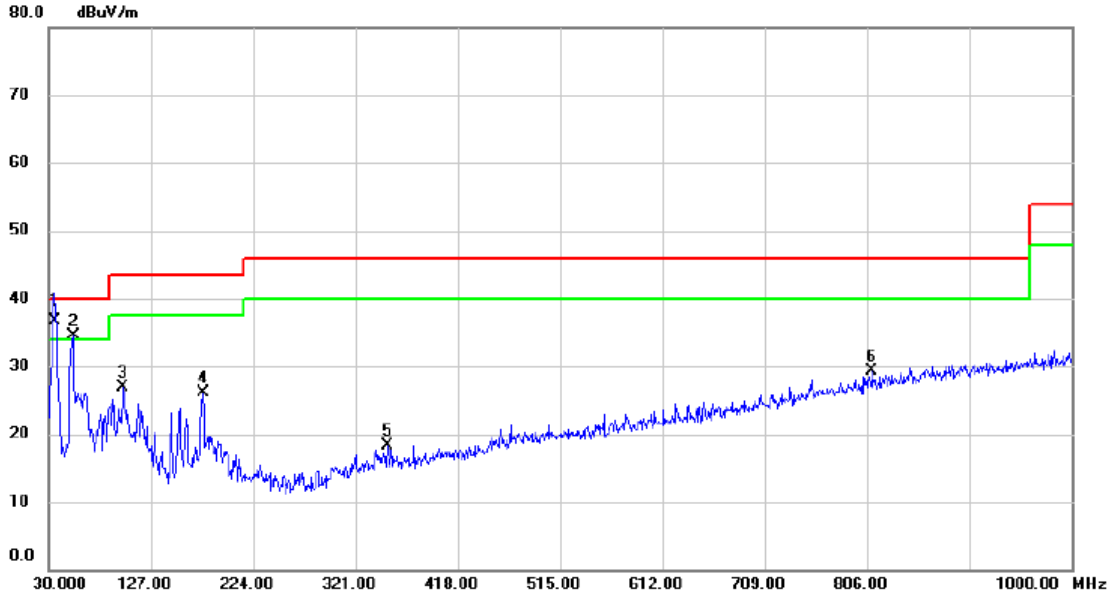

No.	Mk.	Freq. MHz	Reading Level dBuV	Correct Factor dB	Measure- ment dBuV/m	Limit dBuV/m	Margin dB	Detector	Comment
1	*	35.820	51.16	-14.51	36.65	40.00	-3.35	QP	
2	!	53.280	48.29	-13.88	34.41	40.00	-5.59	peak	
3		100.810	44.26	-17.38	26.88	43.50	-16.62	peak	
4		176.470	38.33	-12.14	26.19	43.50	-17.31	peak	
5		351.070	30.22	-11.94	18.28	46.00	-27.72	peak	
6		810.850	30.29	-1.06	29.23	46.00	-16.77	peak	

Test Mode: UNII-1/TX A Mode 5180MHz\_ANT1

**Horizontal**

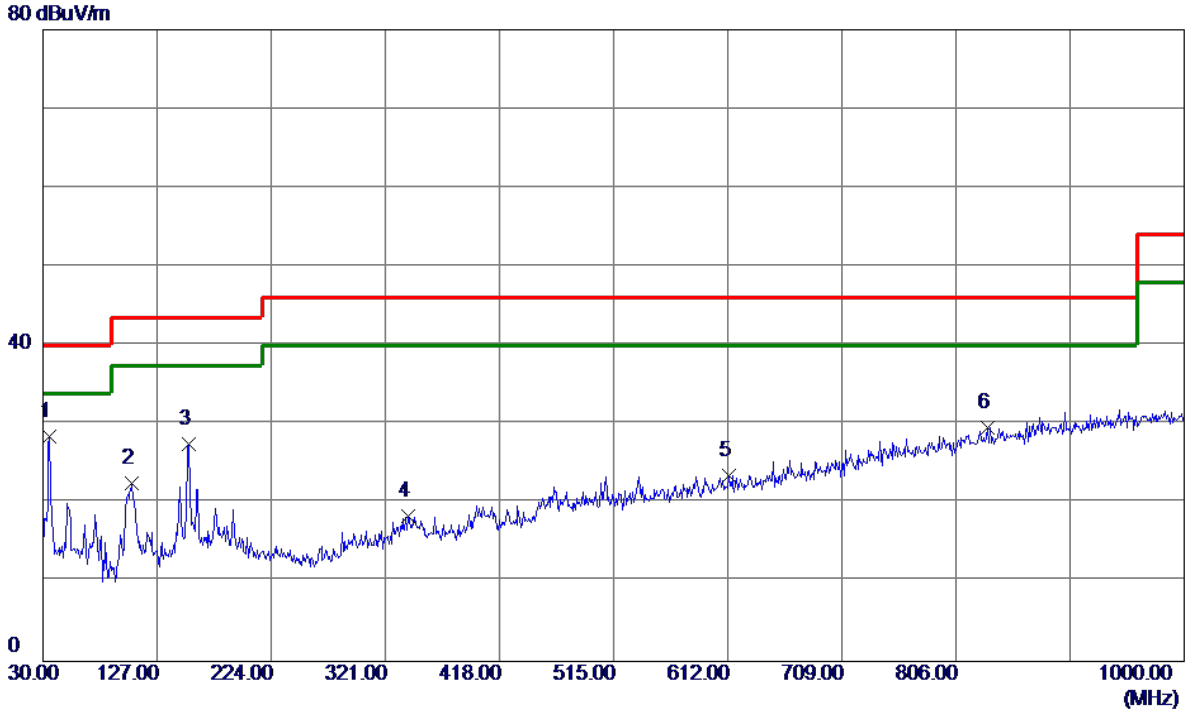

No.	Freq. MHz	Reading Level dBuV/m	Correct Factor dB	Measure ment dBuV/m	Limit dBuV/m	Margin dB	Detector	Comment
1 *	35.8200	43.02	-14.51	28.51	40.00	-11.49	Peak	
2	105.6600	39.25	-16.75	22.50	43.50	-21.00	Peak	
3	154.1600	40.81	-13.28	27.53	43.50	-15.97	Peak	
4	340.4000	30.48	-12.12	18.36	46.00	-27.64	Peak	
5	612.9699	29.66	-6.17	23.49	46.00	-22.51	Peak	
6	833.1599	30.03	-0.46	29.57	46.00	-16.43	Peak	

Test Mode: UNII-1/TX A Mode 5200MHz\_ANT1

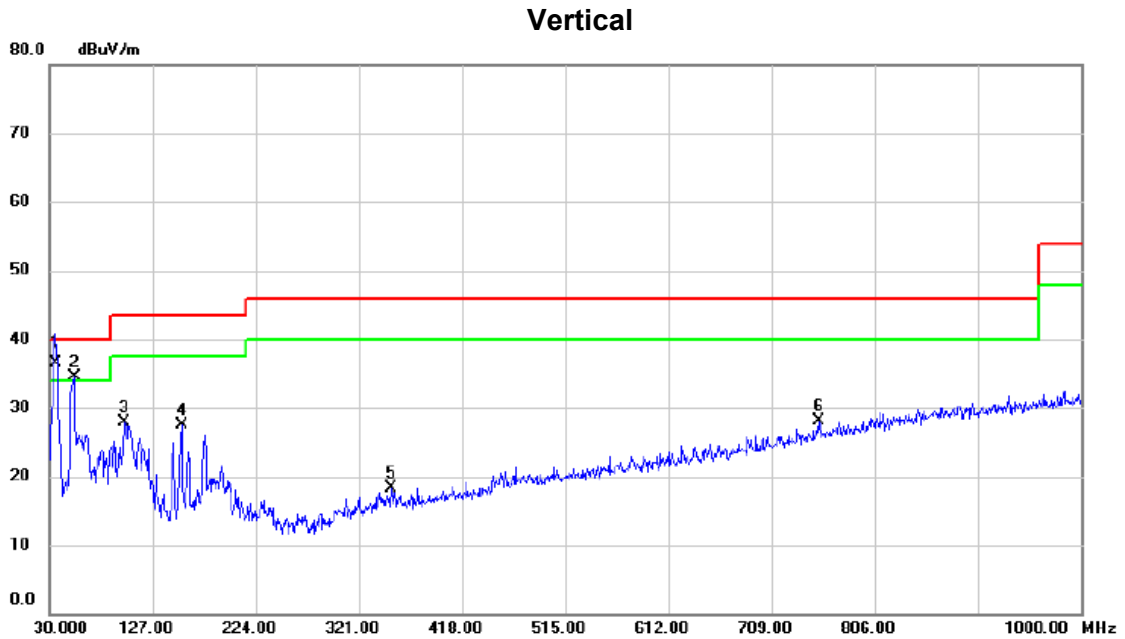

No.	Mk.	Freq. MHz	Reading Level dBuV	Correct Factor dB	Measure- ment dBuV/m	Limit dBuV/m	Margin dB	Detector	Comment
1	*	35.820	51.11	-14.51	36.60	40.00	-3.40	QP	
2	!	53.280	48.29	-13.88	34.41	40.00	-5.59	peak	
3		100.810	45.33	-17.38	27.95	43.50	-15.55	peak	
4		154.160	40.83	-13.28	27.55	43.50	-15.95	peak	
5		351.070	30.22	-11.94	18.28	46.00	-27.72	peak	
6		753.620	30.53	-2.36	28.17	46.00	-17.83	peak	

Test Mode: UNII-1/TX A Mode 5200MHz\_ANT1

**Horizontal**

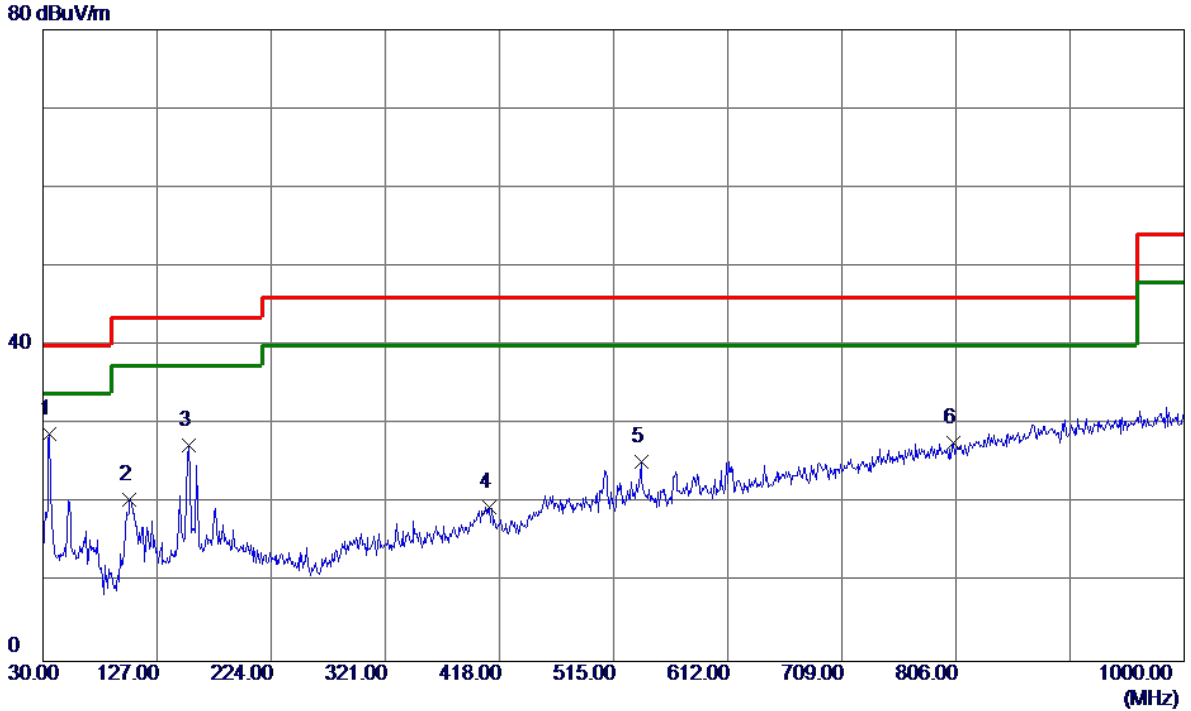

No.	Freq. MHz	Reading Level dBuV/m	Correct Factor dB	Measure ment dBuV/m	Limit dBuV/m	Margin dB	Detector	Comment
1 *	35.8200	43.28	-14.51	28.77	40.00	-11.23	Peak	
2	103.7200	37.54	-17.00	20.54	43.50	-22.96	Peak	
3	154.1600	40.66	-13.28	27.38	43.50	-16.12	Peak	
4	409.2700	30.61	-11.10	19.51	46.00	-26.49	Peak	
5	538.2800	33.23	-7.95	25.28	46.00	-20.72	Peak	
6	804.0600	29.00	-1.25	27.75	46.00	-18.25	Peak	

Test Mode: UNII-1/TX A Mode 5240MHz\_ANT1

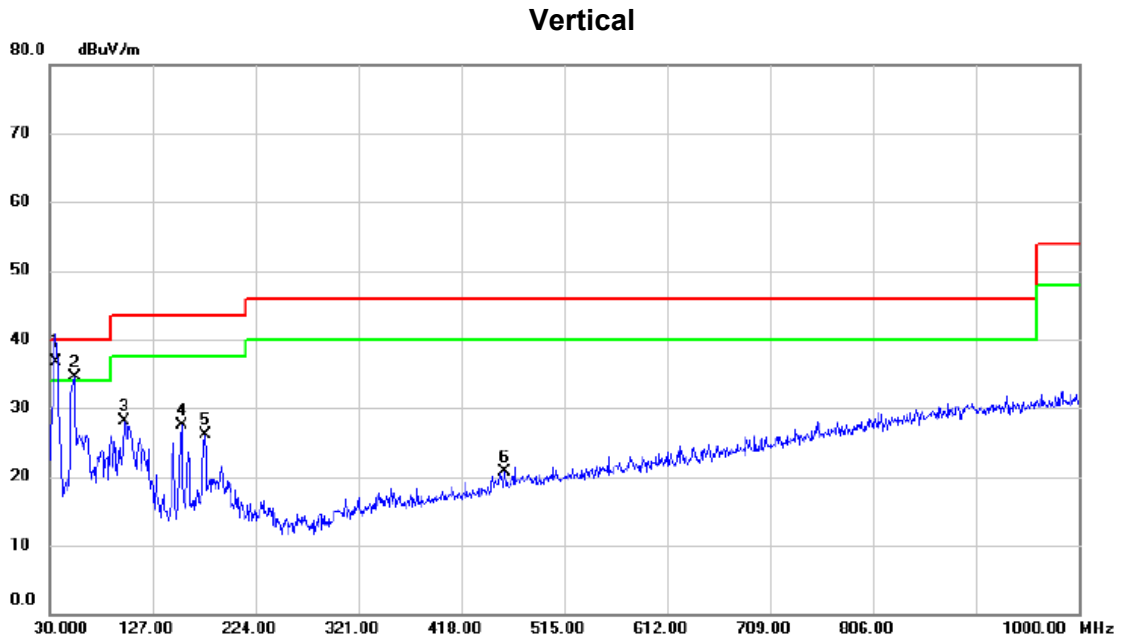

No.	Mk.	Freq. MHz	Reading Level dBuV	Correct Factor dB	Measure- ment dBuV/m	Limit dBuV/m	Margin dB	Detector	Comment
1	*	35.820	51.25	-14.51	36.74	40.00	-3.26	QP	
2	!	53.280	48.29	-13.88	34.41	40.00	-5.59	peak	
3		100.810	45.42	-17.38	28.04	43.50	-15.46	peak	
4		154.160	40.83	-13.28	27.55	43.50	-15.95	peak	
5		176.470	38.33	-12.14	26.19	43.50	-17.31	peak	
6		458.740	30.50	-9.72	20.78	46.00	-25.22	peak	

Test Mode: UNII-1/TX A Mode 5240MHz\_ANT1

**Horizontal**

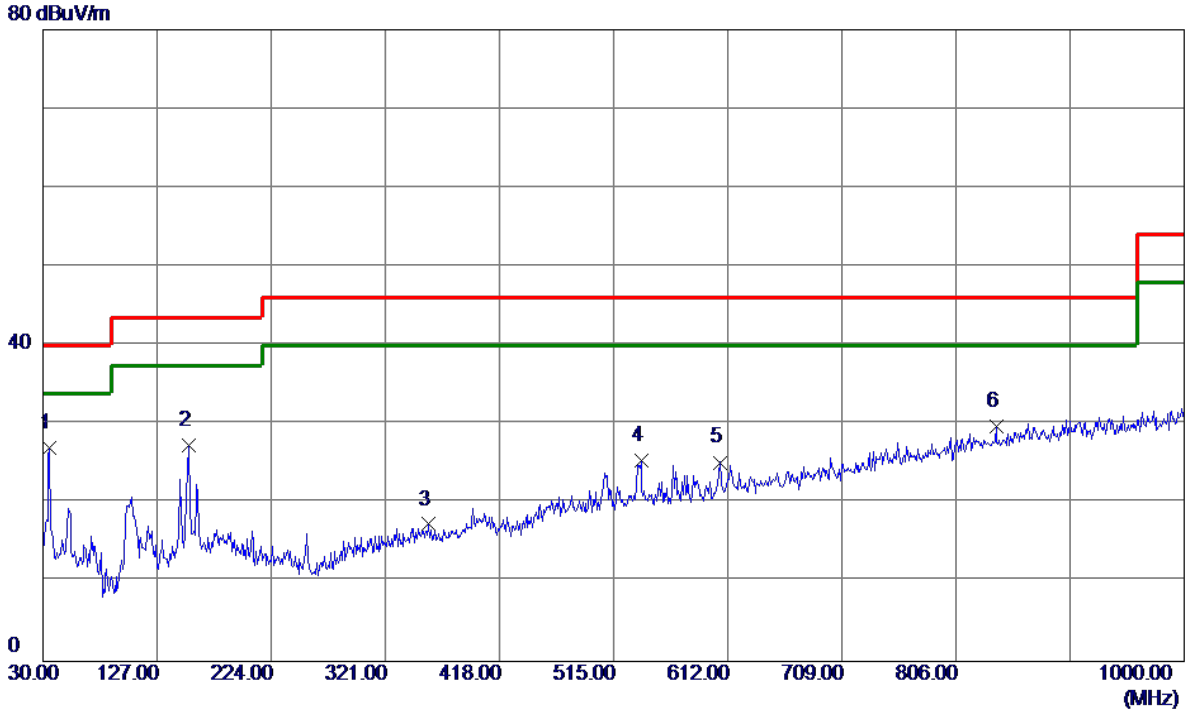

No.	Freq. MHz	Reading Level dBuV/m	Correct Factor dB	Measure ment dBuV/m	Limit dBuV/m	Margin dB	Detector	Comment
1 *	35.8200	41.49	-14.51	26.98	40.00	-13.02	Peak	
2	154.1600	40.63	-13.28	27.35	43.50	-16.15	Peak	
3	357.8599	29.22	-11.86	17.36	46.00	-28.64	Peak	
4	538.2800	33.40	-7.95	25.45	46.00	-20.55	Peak	
5	605.2100	31.52	-6.32	25.20	46.00	-20.80	Peak	
6	839.9500	30.00	-0.27	29.73	46.00	-16.27	Peak	

Test Mode: UNII-2A/TX A Mode 5260MHz\_ANT1

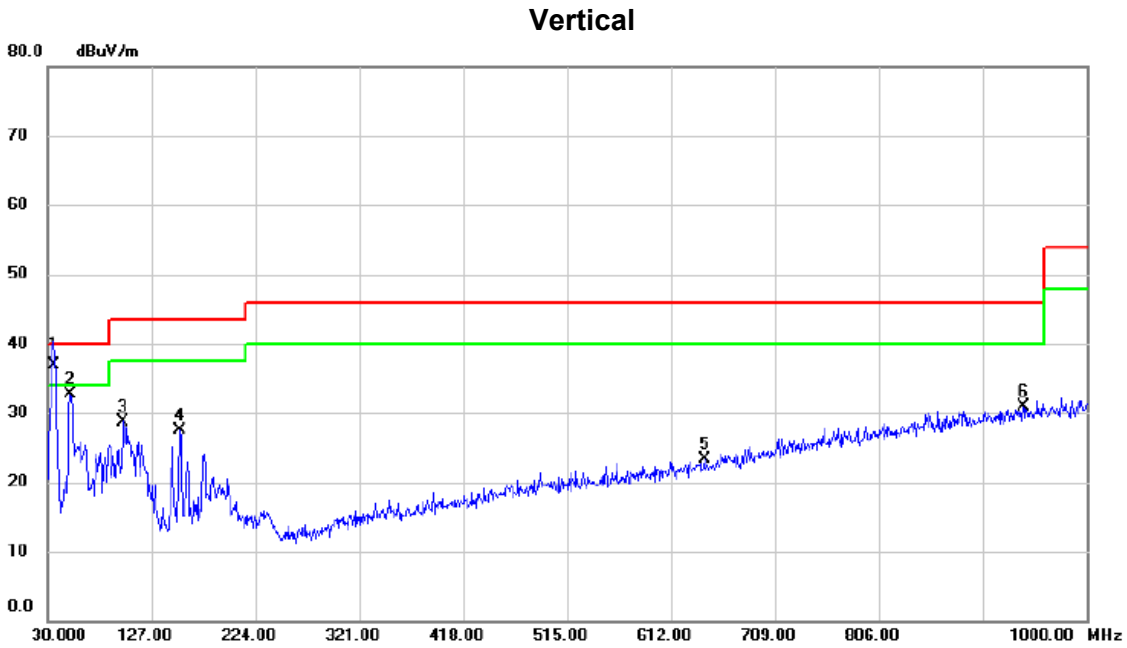

No.	Mk.	Freq. MHz	Reading Level dBuV	Correct Factor dB	Measure- ment dBuV/m	Limit dBuV/m	Margin dB	Detector	Comment
1	*	35.820	51.40	-14.51	36.89	40.00	-3.11	QP	
2		51.340	46.41	-13.70	32.71	40.00	-7.29	peak	
3		100.810	46.18	-17.38	28.80	43.50	-14.70	peak	
4		153.190	40.89	-13.33	27.56	43.50	-15.94	peak	
5		643.040	28.84	-5.61	23.23	46.00	-22.77	peak	
6		940.830	29.09	1.82	30.91	46.00	-15.09	peak	

Test Mode: UNII-2A/TX A Mode 5260MHz\_ANT1

Horizontal

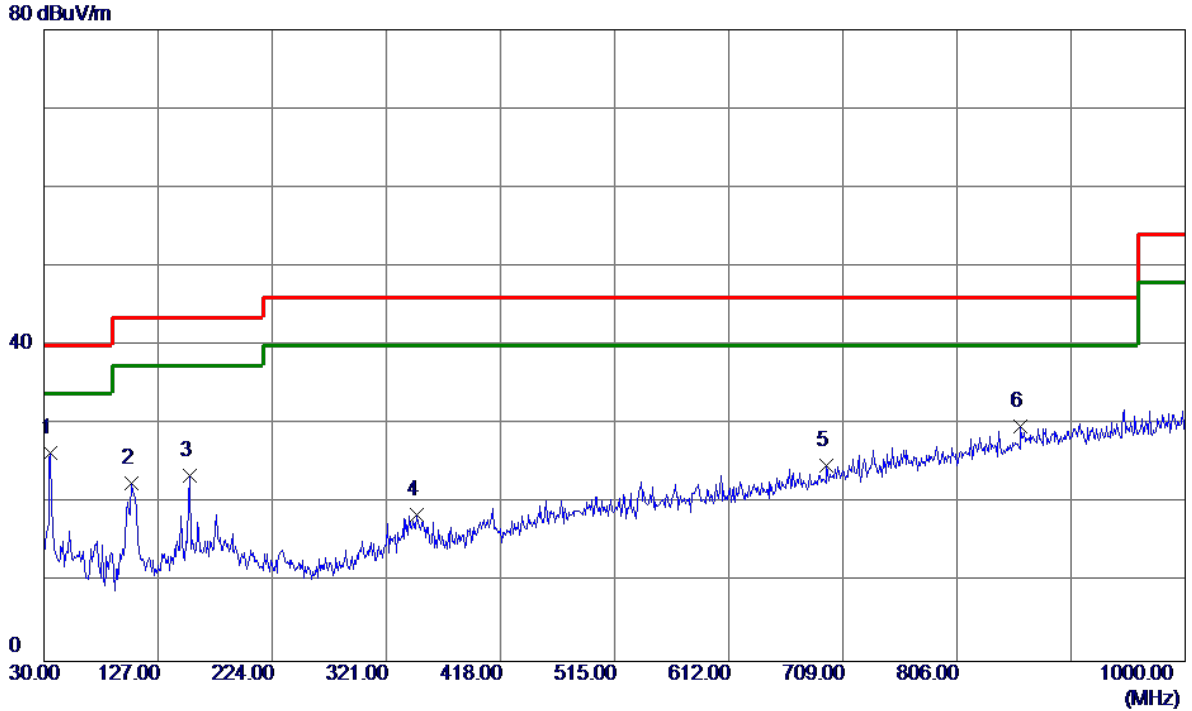

No.	Freq. MHz	Reading Level dBuV/m	Correct Factor dB	Measure ment dBuV/m	Limit dBuV/m	Margin dB	Detector	Comment
1 *	35.8200	40.92	-14.51	26.41	40.00	-13.59	Peak	
2	104.6900	39.46	-16.87	22.59	43.50	-20.91	Peak	
3	154.1600	36.86	-13.28	23.58	43.50	-19.92	Peak	
4	347.1900	30.63	-12.00	18.63	46.00	-27.37	Peak	
5	695.4200	28.87	-4.08	24.79	46.00	-21.21	Peak	
6	860.3200	29.57	0.21	29.78	46.00	-16.22	Peak	



Test Mode: UNII-2A/TX A Mode 5300MHz\_ANT1

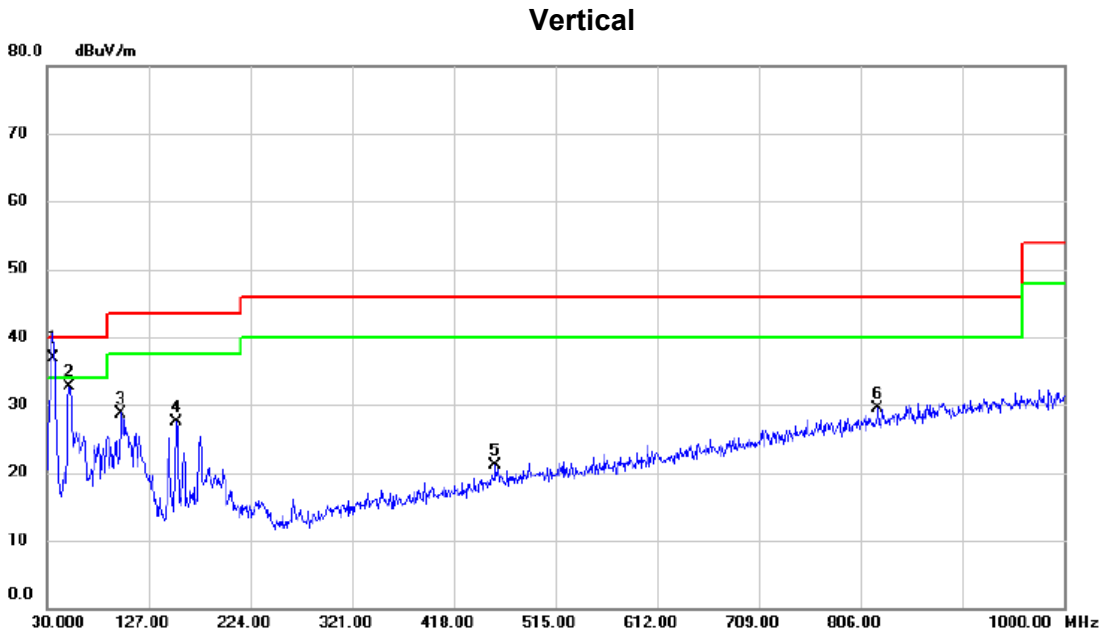

No.	Mk.	Freq. MHz	Reading Level dBuV	Correct Factor dB	Measure- ment dBuV/m	Limit dBuV/m	Margin dB	Detector	Comment
1	*	35.820	51.32	-14.51	36.81	40.00	-3.19	QP	
2		51.340	46.41	-13.70	32.71	40.00	-7.29	peak	
3		100.810	46.18	-17.38	28.80	43.50	-14.70	peak	
4		153.190	40.89	-13.33	27.56	43.50	-15.94	peak	
5		457.770	30.79	-9.75	21.04	46.00	-24.96	peak	
6		822.490	30.29	-0.75	29.54	46.00	-16.46	peak	

Test Mode: UNII-2A/TX A Mode 5300MHz\_ANT1

**Horizontal**

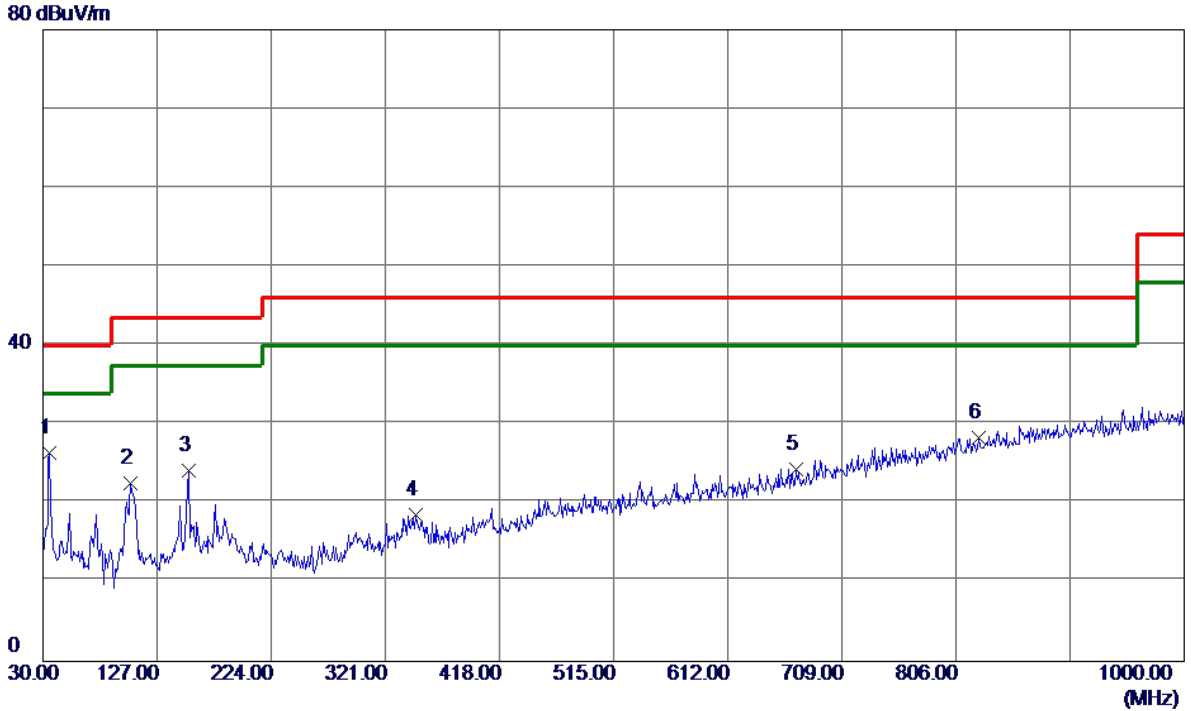

No.	Freq. MHz	Reading Level dBuV/m	Correct Factor dB	Measure ment dBuV/m	Limit dBuV/m	Margin dB	Detector	Comment
1 *	35.8200	40.92	-14.51	26.41	40.00	-13.59	Peak	
2	104.6900	39.46	-16.87	22.59	43.50	-20.91	Peak	
3	154.1600	37.50	-13.28	24.22	43.50	-19.28	Peak	
4	347.1900	30.63	-12.00	18.63	46.00	-27.37	Peak	
5	670.2000	29.15	-4.85	24.30	46.00	-21.70	Peak	
6	825.4000	29.02	-0.67	28.35	46.00	-17.65	Peak	

Test Mode: UNII-2A/TX A Mode 5320MHz\_ANT1

Vertical

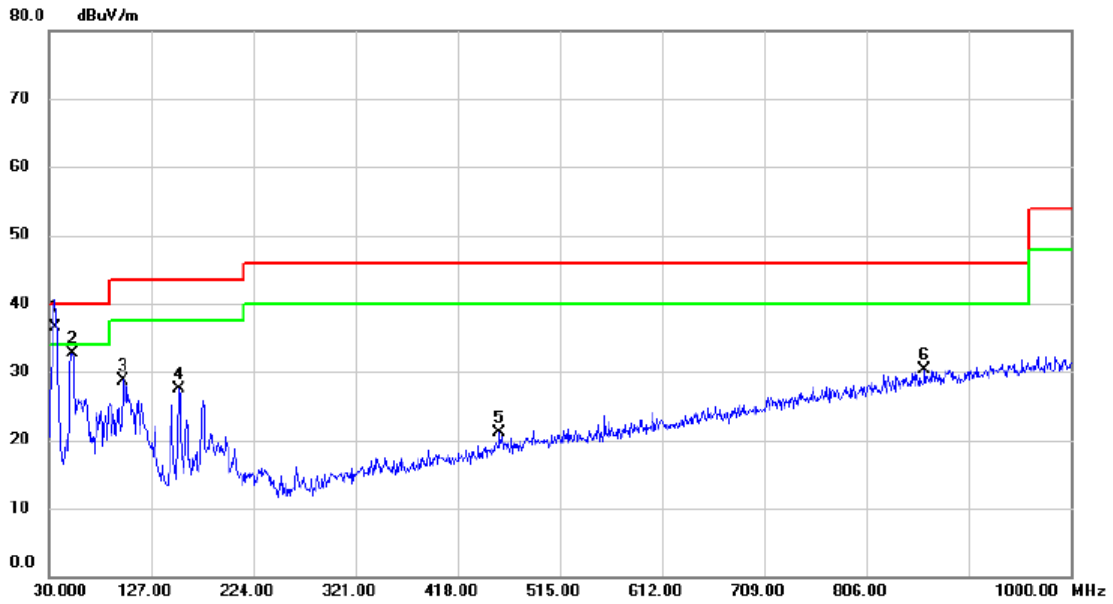

No.	Mk.	Freq. MHz	Reading Level dBuV	Correct Factor dB	Measure- ment dBuV/m	Limit dBuV/m	Margin dB	Detector	Comment
1	*	35.820	51.09	-14.51	36.58	40.00	-3.42	QP	
2		52.310	46.54	-13.79	32.75	40.00	-7.25	peak	
3		100.810	46.18	-17.38	28.80	43.50	-14.70	peak	
4		153.190	40.89	-13.33	27.56	43.50	-15.94	peak	
5		457.770	30.79	-9.75	21.04	46.00	-24.96	peak	
6		861.290	29.99	0.24	30.23	46.00	-15.77	peak	

Test Mode: UNII-2A/TX A Mode 5320MHz\_ANT1

**Horizontal**

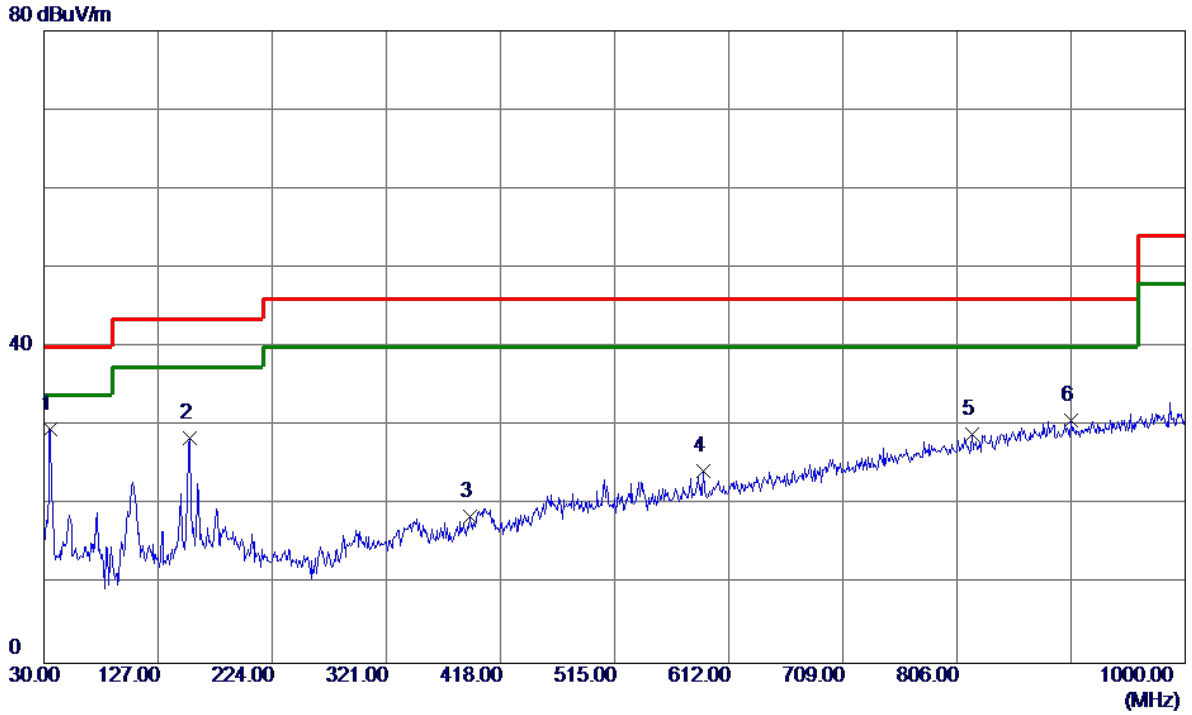

No.	Freq. MHz	Reading Level dBuV/m	Correct Factor dB	Measure ment dBuV/m	Limit dBuV/m	Margin dB	Detector	Comment
1 *	35.8200	44.15	-14.51	29.64	40.00	-10.36	Peak	
2	154.1600	41.83	-13.28	28.55	43.50	-14.95	Peak	
3	391.8100	30.01	-11.46	18.55	46.00	-27.45	Peak	
4	590.6599	31.04	-6.66	24.38	46.00	-21.62	Peak	
5	818.6100	29.83	-0.85	28.98	46.00	-17.02	Peak	
6	903.0000	29.70	1.09	30.79	46.00	-15.21	Peak	

Test Mode: UNII-2C/TX A Mode 5500MHz\_ANT1

Vertical

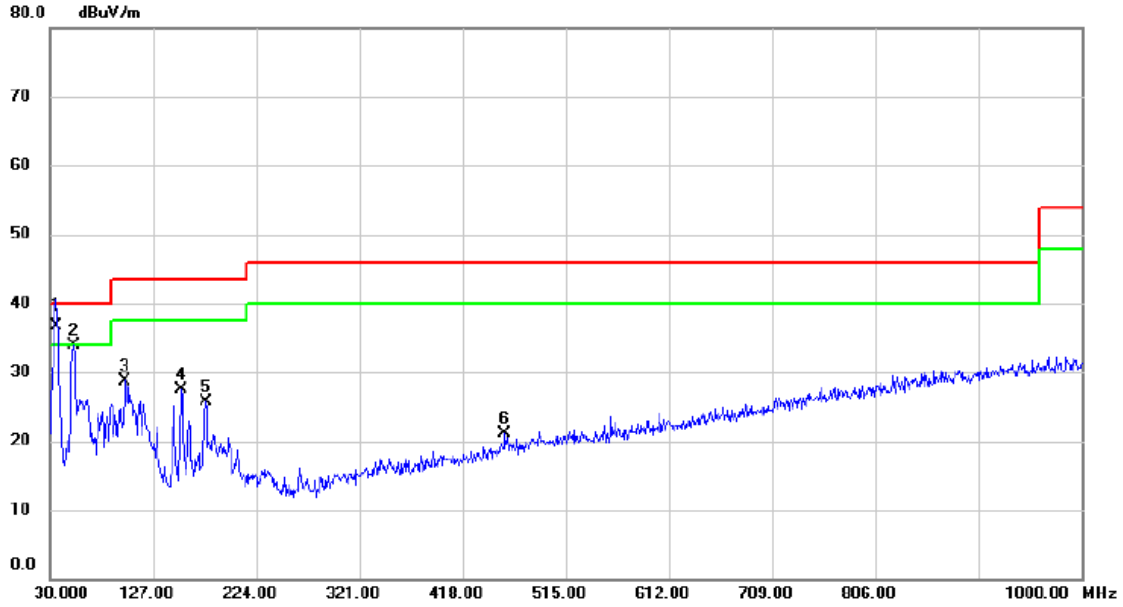

No.	Mk.	Freq. MHz	Reading Level dBuV	Correct Factor dB	Measure- ment dBuV/m	Limit dBuV/m	Margin dB	Detector	Comment
1	*	35.820	51.28	-14.51	36.77	40.00	-3.23	QP	
2		52.310	47.65	-13.79	33.86	40.00	-6.14	peak	
3		100.810	46.18	-17.38	28.80	43.50	-14.70	peak	
4		153.190	40.89	-13.33	27.56	43.50	-15.94	peak	
5		176.470	37.83	-12.14	25.69	43.50	-17.81	peak	
6		457.770	30.79	-9.75	21.04	46.00	-24.96	peak	

Test Mode: UNII-2C/TX A Mode 5500MHz\_ANT1

**Horizontal**

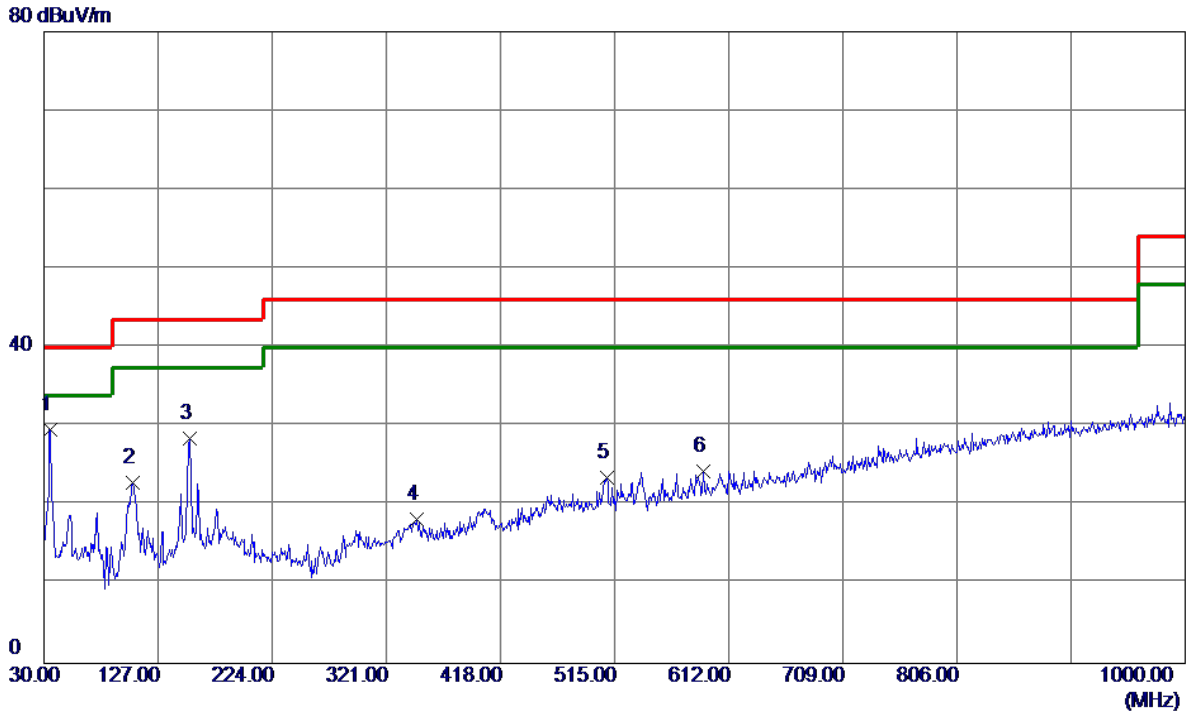

No.	Freq. MHz	Reading Level dBuV/m	Correct Factor dB	Measure ment dBuV/m	Limit dBuV/m	Margin dB	Detector	Comment
1 *	35.8200	44.15	-14.51	29.64	40.00	-10.36	Peak	
2	105.6600	39.61	-16.75	22.86	43.50	-20.64	Peak	
3	154.1600	41.83	-13.28	28.55	43.50	-14.95	Peak	
4	347.1900	30.26	-12.00	18.26	46.00	-27.74	Peak	
5	508.2100	32.05	-8.56	23.49	46.00	-22.51	Peak	
6	590.6599	31.04	-6.66	24.38	46.00	-21.62	Peak	

Test Mode: UNII-2C/TX A Mode 5580MHz\_ANT1

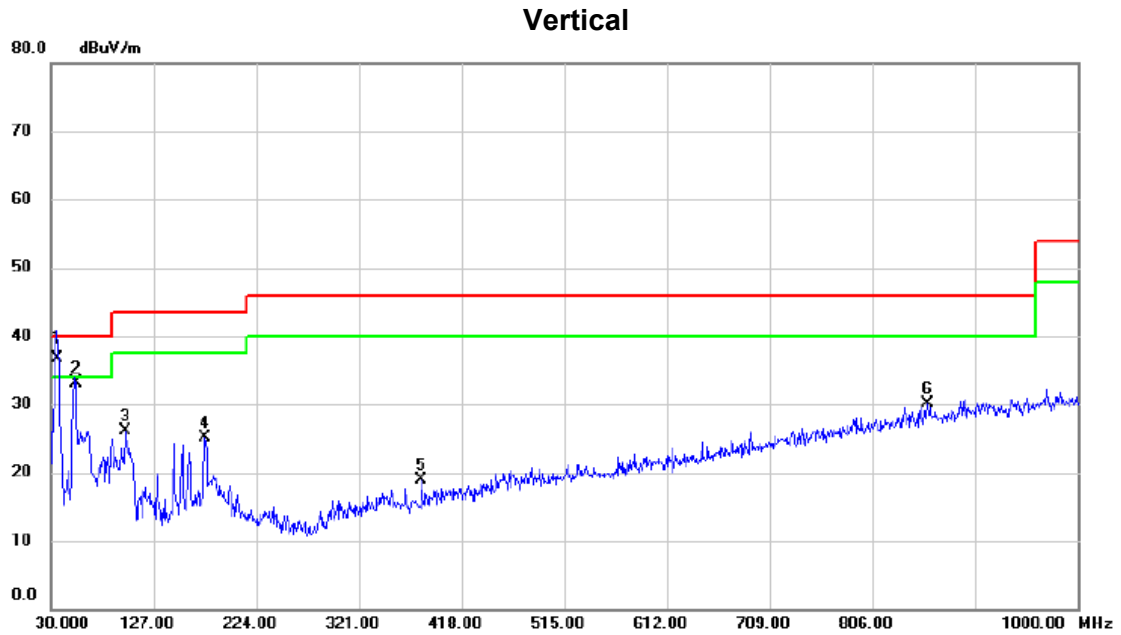

No.	Mk.	Freq. MHz	Reading Level dBuV	Correct Factor dB	Measure- ment dBuV/m	Limit dBuV/m	Margin dB	Detector	Comment
1	*	35.820	51.19	-14.51	36.68	40.00	-3.32	QP	
2		53.280	47.03	-13.88	33.15	40.00	-6.85	peak	
3		100.810	43.48	-17.38	26.10	43.50	-17.40	peak	
4		175.500	37.21	-12.18	25.03	43.50	-18.47	peak	
5		380.170	30.46	-11.60	18.86	46.00	-27.14	peak	
6		858.380	30.00	0.18	30.18	46.00	-15.82	peak	

Test Mode: UNII-2C/TX A Mode 5580MHz\_ANT1

**Horizontal**

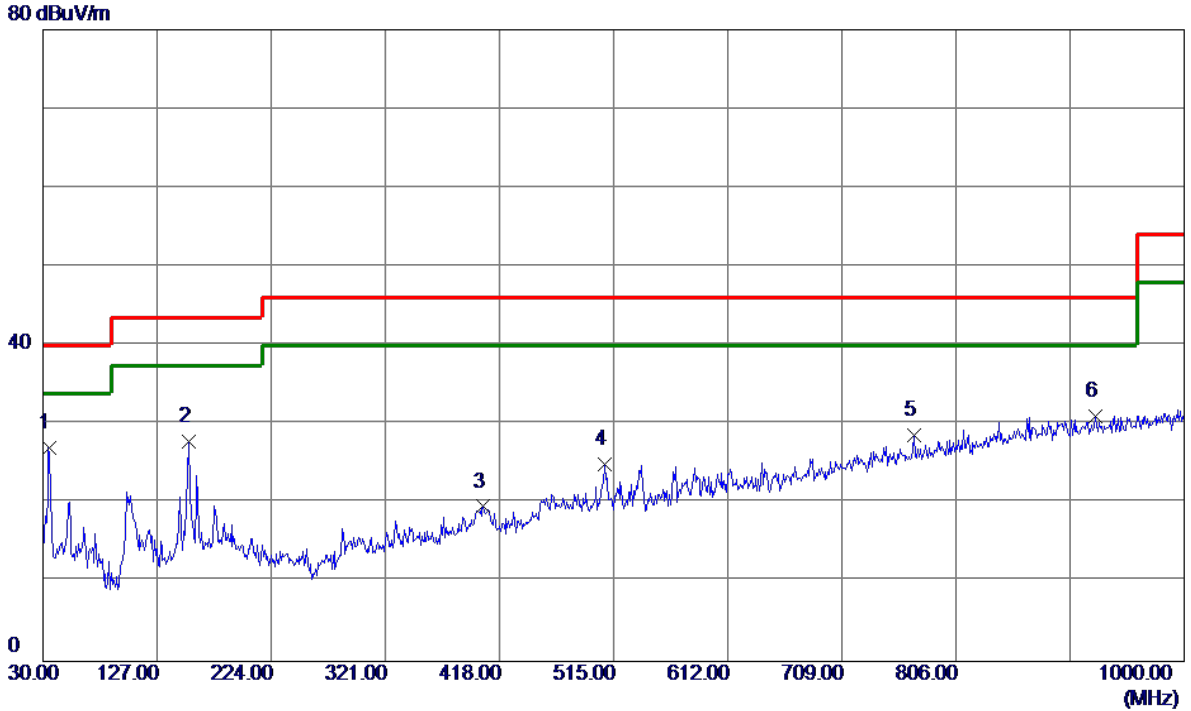

No.	Freq. MHz	Reading Level dBuV/m	Correct Factor dB	Measure ment dBuV/m	Limit dBuV/m	Margin dB	Detector	Comment
1 *	34.8500	41.66	-14.62	27.04	40.00	-12.96	Peak	
2	154.1600	41.17	-13.28	27.89	43.50	-15.61	Peak	
3	404.4200	30.83	-11.23	19.60	46.00	-26.40	Peak	
4	507.2400	33.60	-8.57	25.03	46.00	-20.97	Peak	
5	770.1100	30.70	-2.01	28.69	46.00	-17.31	Peak	
6	924.3400	29.58	1.50	31.08	46.00	-14.92	Peak	



Test Mode: UNII-2C/TX A Mode 5700MHz\_ANT1

**Vertical**

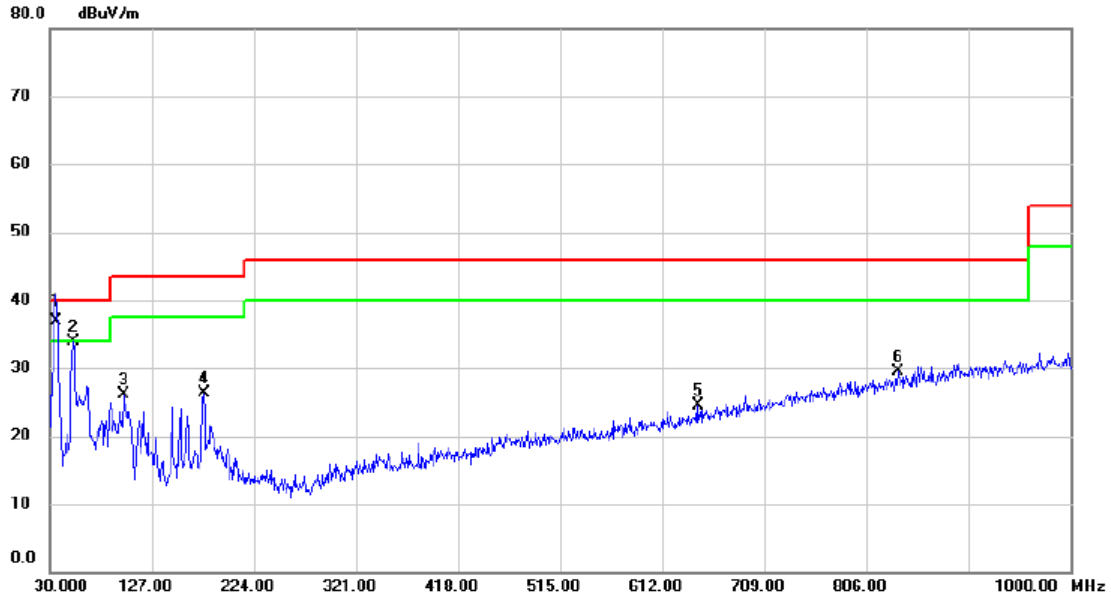

No.	Mk.	Freq. MHz	Reading Level dBuV	Correct Factor dB	Measure- ment dBuV/m	Limit dBuV/m	Margin dB	Detector	Comment
1	*	35.820	51.39	-14.51	36.88	40.00	-3.12	QP	
2		52.310	47.64	-13.79	33.85	40.00	-6.15	peak	
3		100.810	43.48	-17.38	26.10	43.50	-17.40	peak	
4		176.470	38.39	-12.14	26.25	43.50	-17.25	peak	
5		645.950	30.05	-5.56	24.49	46.00	-21.51	peak	
6		836.070	29.88	-0.38	29.50	46.00	-16.50	peak	

Test Mode: UNII-2C/TX A Mode 5700MHz\_ANT1

**Horizontal**

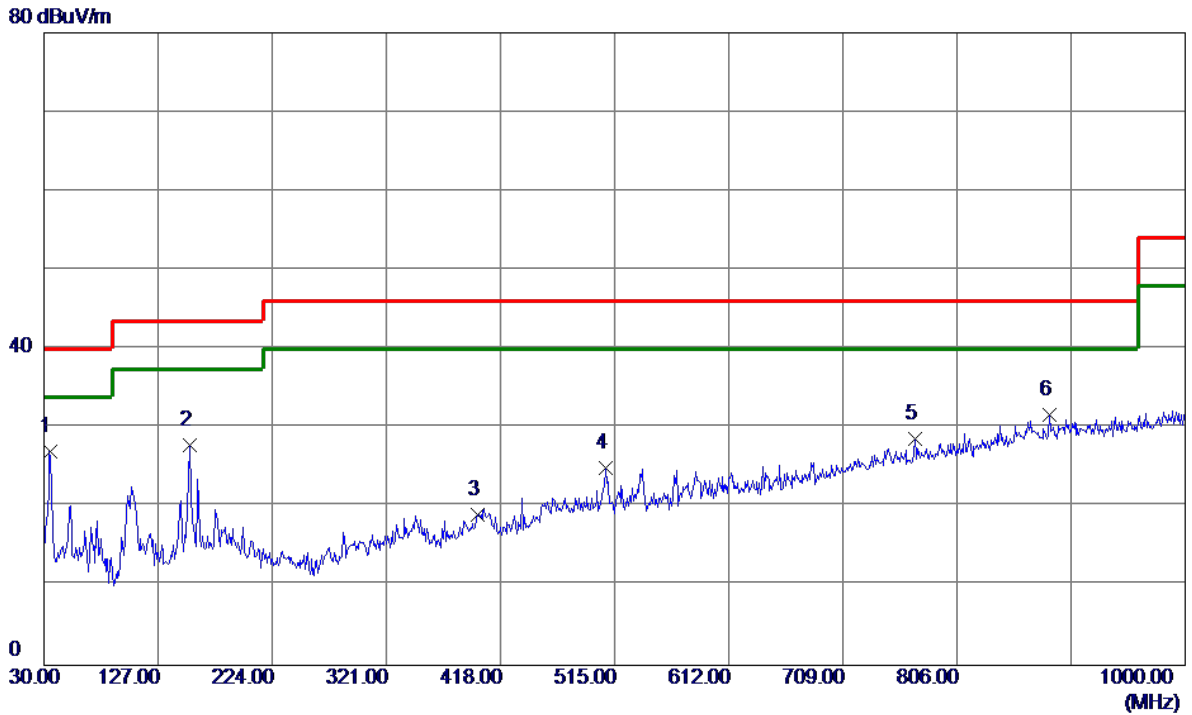

No.	Freq. MHz	Reading Level dBuV/m	Correct Factor dB	Measure ment dBuV/m	Limit dBuV/m	Margin dB	Detector	Comment
1 *	34.8500	41.66	-14.62	27.04	40.00	-12.96	Peak	
2	154.1600	41.17	-13.28	27.89	43.50	-15.61	Peak	
3	398.6000	30.42	-11.38	19.04	46.00	-26.96	Peak	
4	507.2400	33.60	-8.57	25.03	46.00	-20.97	Peak	
5	770.1100	30.70	-2.01	28.69	46.00	-17.31	Peak	
6	884.5700	30.98	0.71	31.69	46.00	-14.31	Peak	

Test Mode: UNII-3/TX A Mode 5745MHz\_ANT1

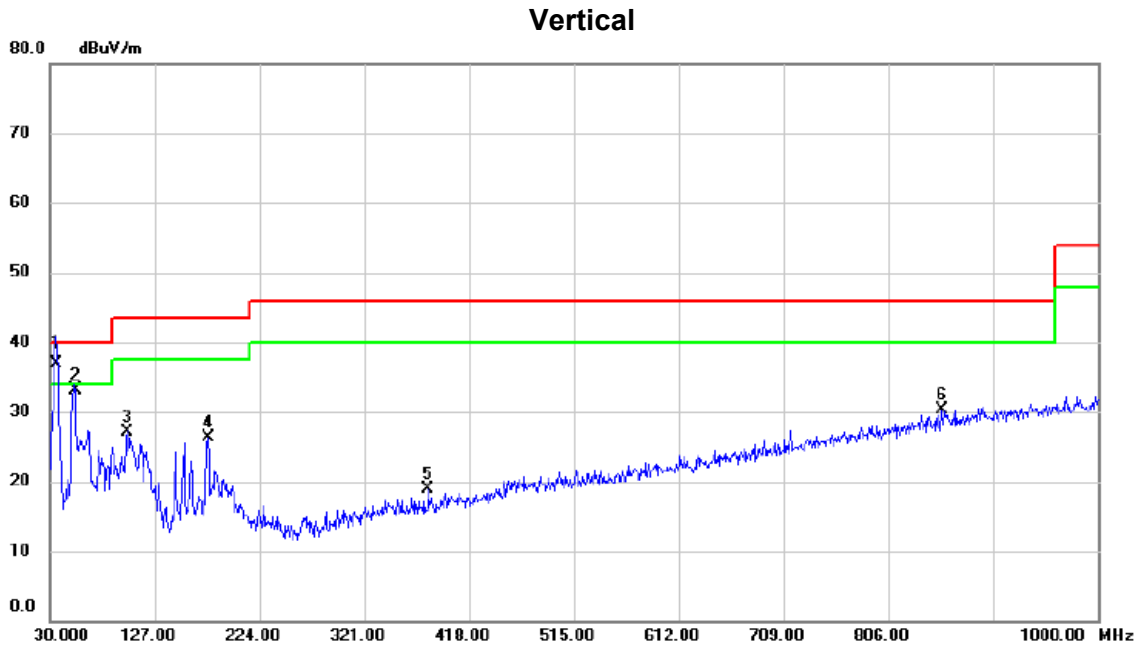

No.	Mk.	Freq. MHz	Reading Level dBuV	Correct Factor dB	Measure- ment dBuV/m	Limit dBuV/m	Margin dB	Detector	Comment
1	*	35.820	51.42	-14.51	36.91	40.00	-3.09	QP	
2		53.280	47.03	-13.88	33.15	40.00	-6.85	peak	
3		101.780	44.45	-17.25	27.20	43.50	-16.30	peak	
4		176.470	38.39	-12.14	26.25	43.50	-17.25	peak	
5		380.170	30.46	-11.60	18.86	46.00	-27.14	peak	
6		855.470	30.21	0.11	30.32	46.00	-15.68	peak	

Test Mode: UNII-3/TX A Mode 5745MHz\_ANT1

**Horizontal**

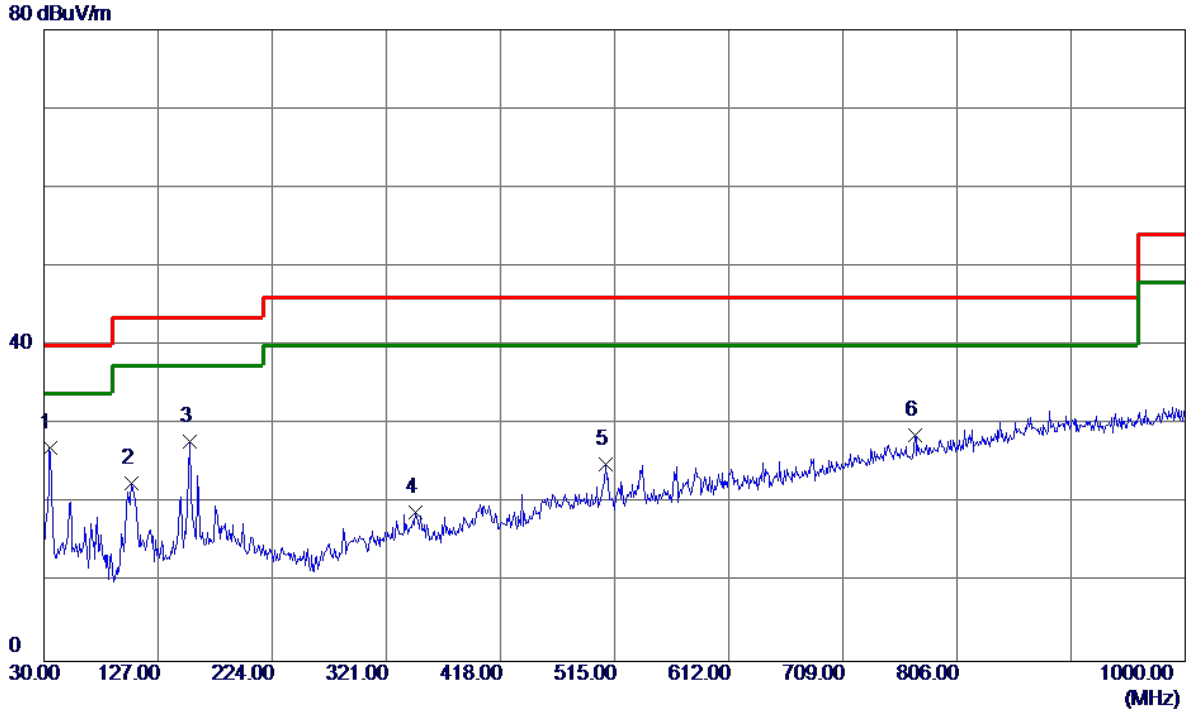

No.	Freq. MHz	Reading Level dBuV/m	Correct Factor dB	Measure ment dBuV/m	Limit dBuV/m	Margin dB	Detector	Comment
1 *	34.8500	41.66	-14.62	27.04	40.00	-12.96	Peak	
2	104.6900	39.44	-16.87	22.57	43.50	-20.93	Peak	
3	154.1600	41.17	-13.28	27.89	43.50	-15.61	Peak	
4	346.2200	30.94	-12.02	18.92	46.00	-27.08	Peak	
5	507.2400	33.60	-8.57	25.03	46.00	-20.97	Peak	
6	770.1100	30.70	-2.01	28.69	46.00	-17.31	Peak	

Test Mode: UNII-3/TX A Mode 5785MHz\_ANT1

**Vertical**

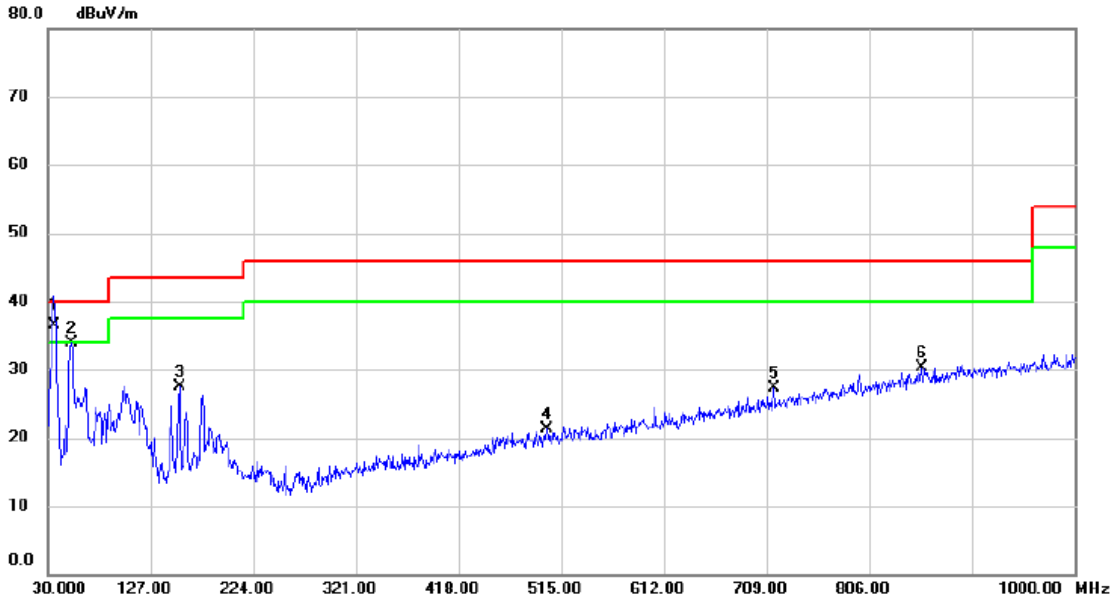

No.	Mk.	Freq. MHz	Reading Level dBuV	Correct Factor dB	Measure- ment dBuV/m	Limit dBuV/m	Margin dB	Detector	Comment
1	*	35.820	51.06	-14.51	36.55	40.00	-3.45	QP	
2		52.310	47.64	-13.79	33.85	40.00	-6.15	peak	
3		154.160	40.73	-13.28	27.45	43.50	-16.05	peak	
4		501.420	29.95	-8.68	21.27	46.00	-24.73	peak	
5		715.790	30.74	-3.47	27.27	46.00	-18.73	peak	
6		855.470	30.21	0.11	30.32	46.00	-15.68	peak	

Test Mode: UNII-3/TX A Mode 5785MHz\_ANT1

**Horizontal**

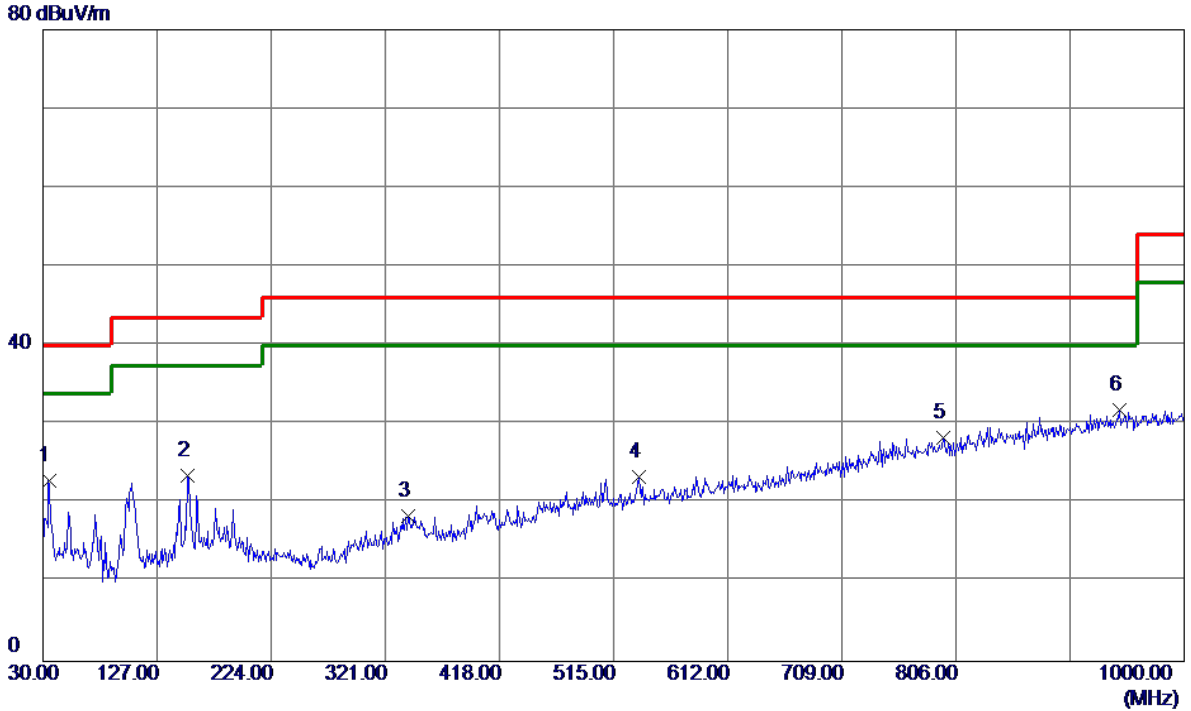

No.	Freq. MHz	Reading Level dBuV/m	Correct Factor dB	Measure ment dBuV/m	Limit dBuV/m	Margin dB	Detector	Comment
1	34.8500	37.49	-14.62	22.87	40.00	-17.13	Peak	
2	153.1900	36.79	-13.34	23.45	43.50	-20.05	Peak	
3	340.4000	30.48	-12.12	18.36	46.00	-27.64	Peak	
4	536.3400	31.40	-7.99	23.41	46.00	-22.59	Peak	
5	795.3300	29.83	-1.46	28.37	46.00	-17.63	Peak	
6 *	944.7100	29.96	1.89	31.85	46.00	-14.15	Peak	

Test Mode: UNII-3/TX A Mode 5825MHz\_ANT1

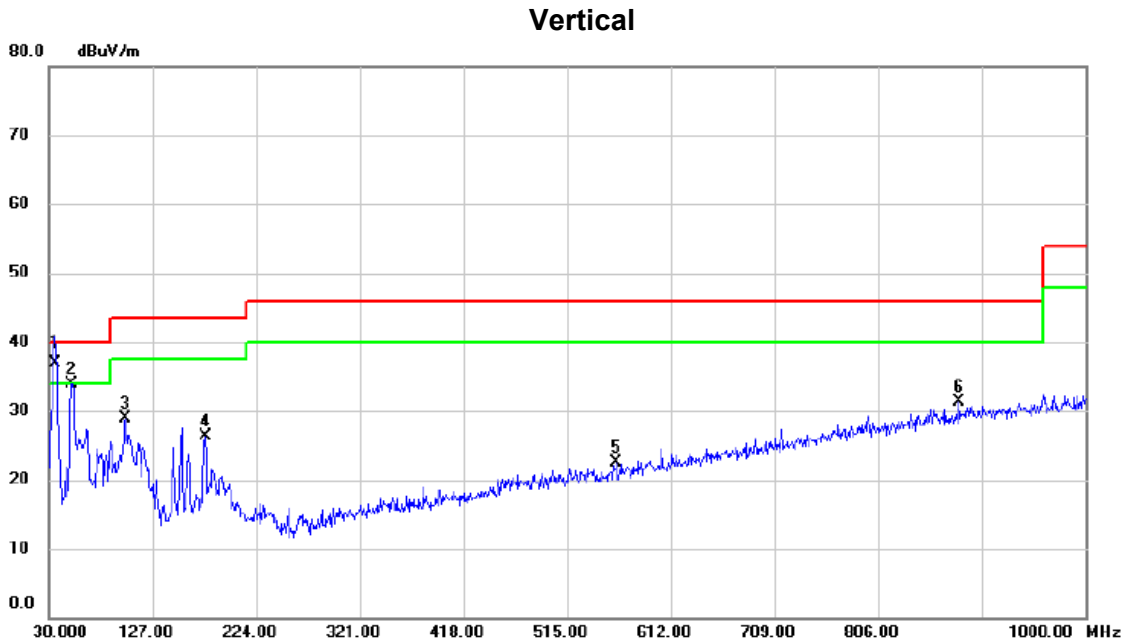

No.	Mk.	Freq. MHz	Reading Level dBuV	Correct Factor dB	Measure- ment dBuV/m	Limit dBuV/m	Margin dB	Detector	Comment
1	*	35.820	51.49	-14.51	36.98	40.00	-3.02	QP	
2		51.340	47.59	-13.70	33.89	40.00	-6.11	peak	
3		101.780	46.12	-17.25	28.87	43.50	-14.63	peak	
4		176.470	38.39	-12.14	26.25	43.50	-17.25	peak	
5		561.560	29.96	-7.41	22.55	46.00	-23.45	peak	
6		881.660	30.65	0.65	31.30	46.00	-14.70	peak	

Test Mode: UNII-3/TX A Mode 5825MHz\_ANT1

**Horizontal**

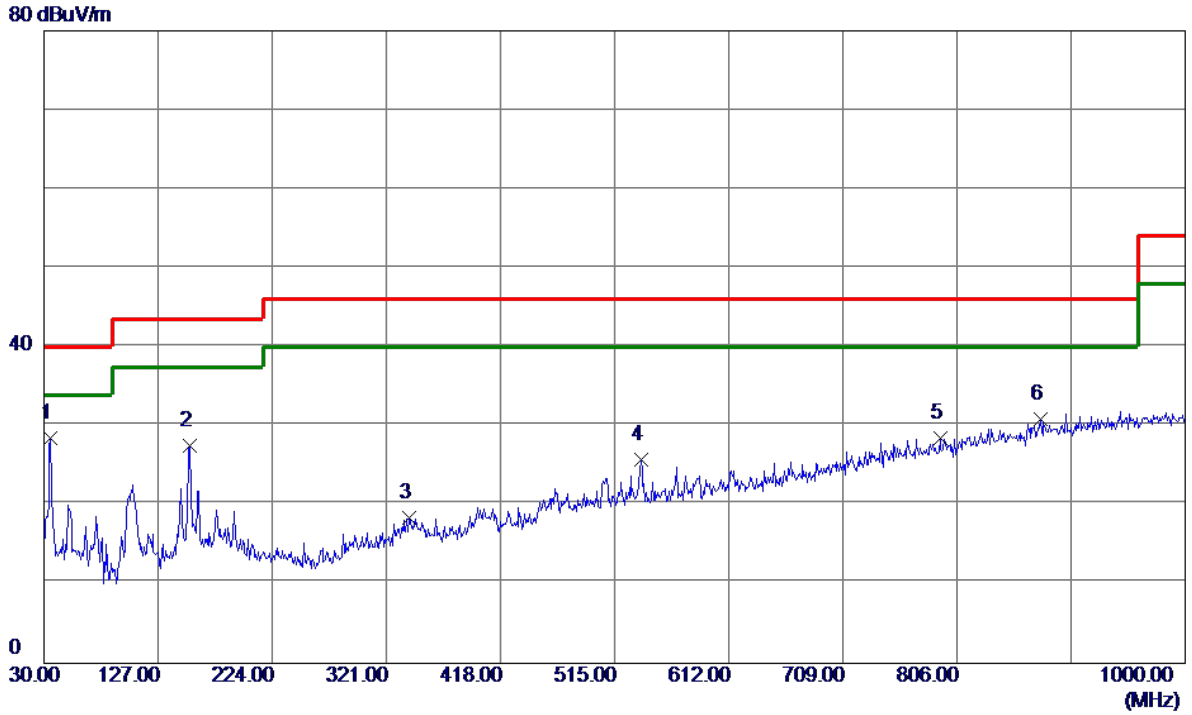

No.	Freq. MHz	Reading Level dBuV/m	Correct Factor dB	Measure ment dBuV/m	Limit dBuV/m	Margin dB	Detector	Comment
1 *	35.8200	43.02	-14.51	28.51	40.00	-11.49	Peak	
2	154.1600	40.81	-13.28	27.53	43.50	-15.97	Peak	
3	340.4000	30.48	-12.12	18.36	46.00	-27.64	Peak	
4	537.3100	33.72	-7.97	25.75	46.00	-20.25	Peak	
5	791.4500	30.08	-1.55	28.53	46.00	-17.47	Peak	
6	876.8100	30.32	0.55	30.87	46.00	-15.13	Peak	



Test Mode: UNII-1/TX A Mode 5180MHz\_ANT2

**Vertical**

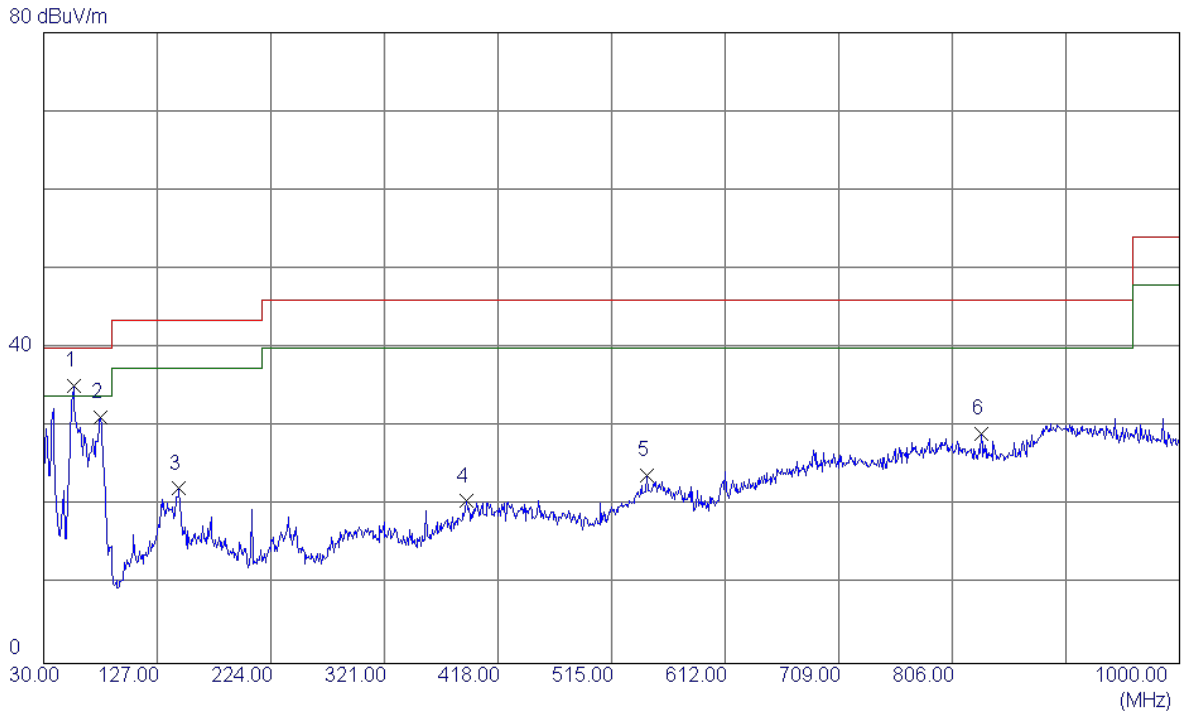

No.	Freq. MHz	Reading Level dBuV/m	Correct Factor dB	Measure ment dBuV/m	Limit dBuV/m	Margin dB	Detector	Comment
1 *	55.7050	48.43	-13.26	35.17	40.00	-4.83	Peak	
2	78.5000	47.33	-16.14	31.19	40.00	-8.81	Peak	
3	145.4299	35.50	-13.34	22.16	43.50	-21.34	Peak	
4	390.8400	29.44	-8.88	20.56	46.00	-25.44	Peak	
5	545.0700	29.65	-5.78	23.87	46.00	-22.13	Peak	
6	830.7350	30.77	-1.70	29.07	46.00	-16.93	Peak	

Remark: This test data is from original report BTL-FCCP-4-1602C038.

Test Mode: UNII-1/TX A Mode 5180MHz\_ANT2

**Horizontal**

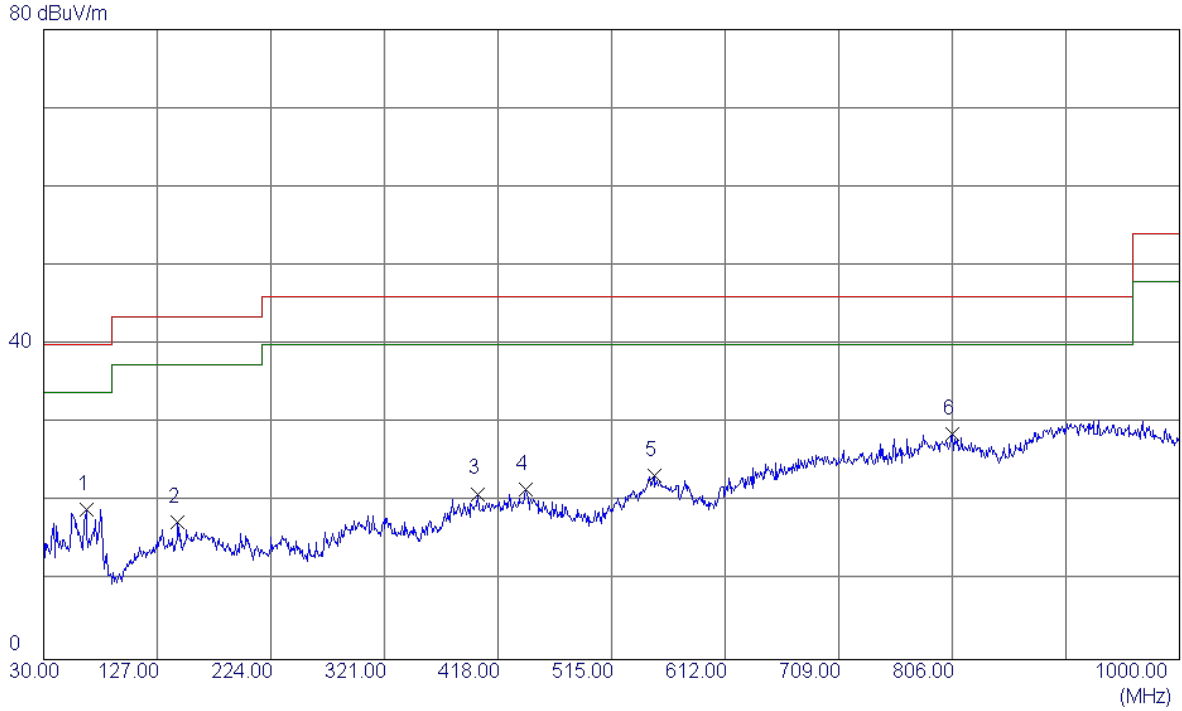

No.	Freq. MHz	Reading Level dBuV/m	Correct Factor dB	Measure ment dBuV/m	Limit dBuV/m	Margin dB	Detector	Comment
1	66.3750	34.58	-15.48	19.10	40.00	-20.90	Peak	
2	144.4600	30.82	-13.42	17.40	43.50	-26.10	Peak	
3	401.0250	29.32	-8.28	21.04	46.00	-24.96	Peak	
4	441.7650	30.09	-8.52	21.57	46.00	-24.43	Peak	
5	551.3750	28.76	-5.35	23.41	46.00	-22.59	Peak	
6 *	806.0000	29.55	-0.93	28.62	46.00	-17.38	Peak	

Remark: This test data is from original report BTL-FCCP-4-1602C038.

Test Mode: UNII-1/TX A Mode 5200MHz\_ANT2

**Vertical**

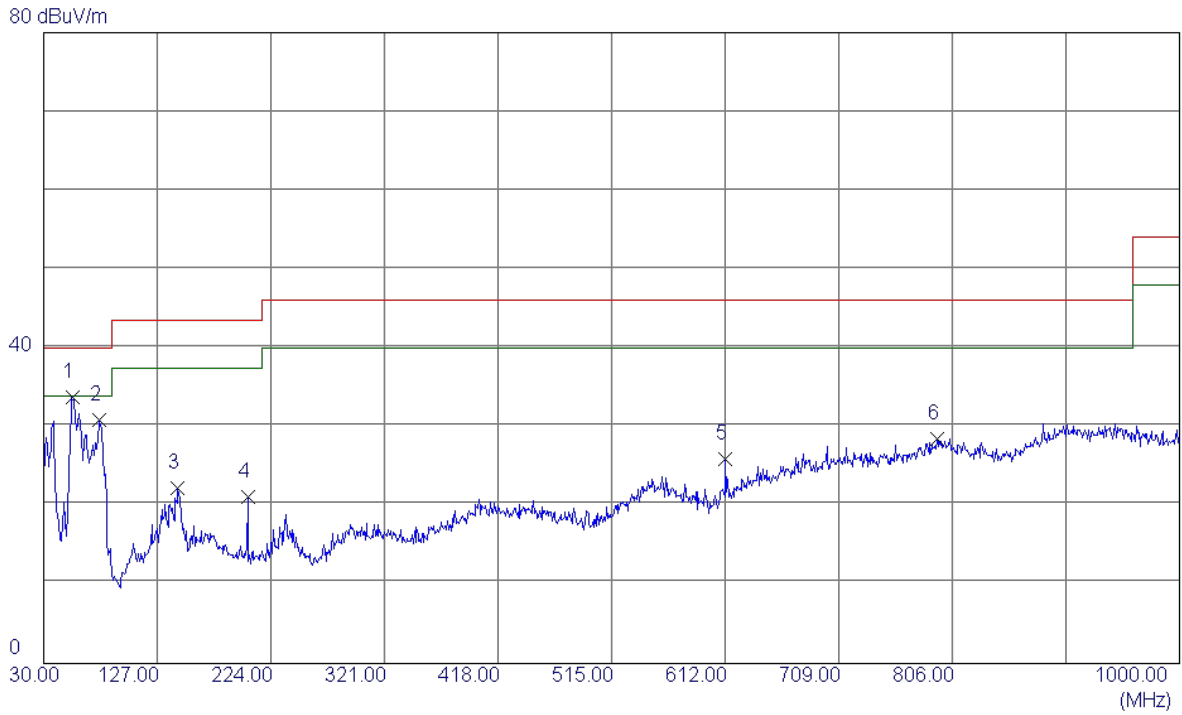

No.	Freq. MHz	Reading Level dBuV/m	Correct Factor dB	Measure ment dBuV/m	Limit dBuV/m	Margin dB	Detector	Comment
1 *	54.2500	47.19	-13.49	33.70	40.00	-6.30	Peak	
2	77.5300	47.14	-16.25	30.89	40.00	-9.11	Peak	
3	144.4600	35.72	-13.42	22.30	43.50	-21.20	Peak	
4	204.1150	35.79	-14.64	21.15	43.50	-22.35	Peak	
5	612.0000	33.18	-7.19	25.99	46.00	-20.01	Peak	
6	792.9050	29.55	-1.05	28.50	46.00	-17.50	Peak	

Remark: This test data is from original report BTL-FCCP-4-1602C038.

Test Mode: UNII-1/TX A Mode 5200MHz\_ANT2

**Horizontal**

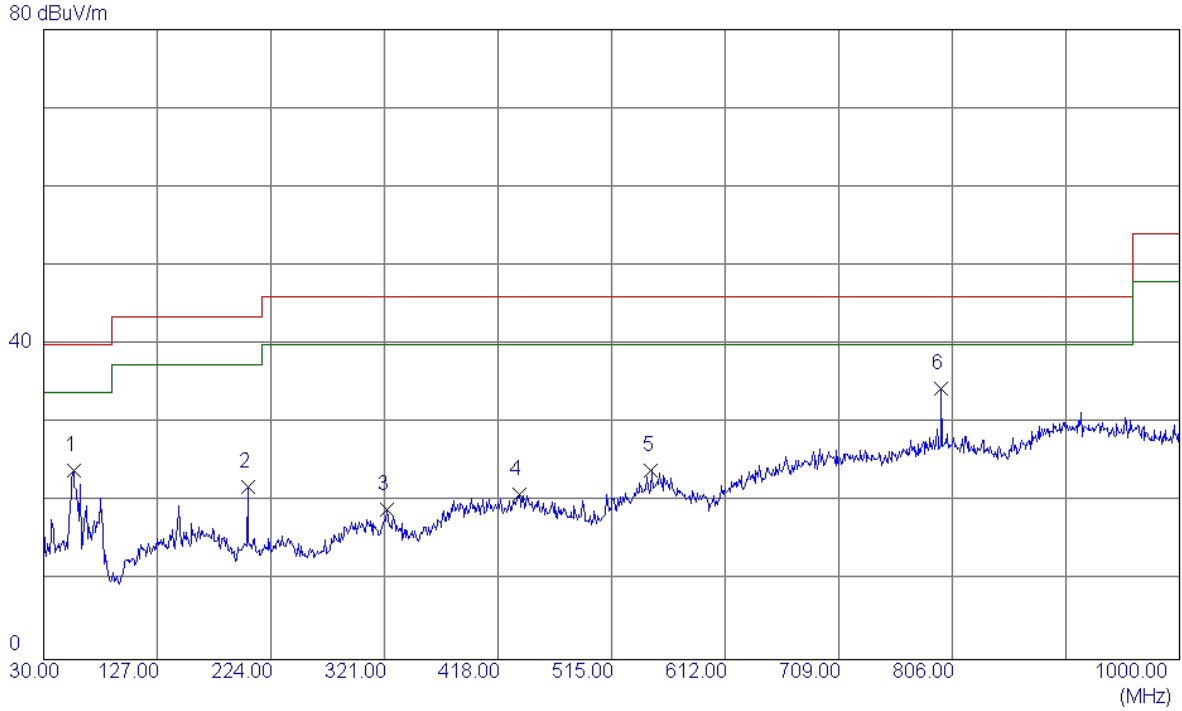

No.	Freq. MHz	Reading Level dBuV/m	Correct Factor dB	Measure ment dBuV/m	Limit dBuV/m	Margin dB	Detector	Comment
1	55.7050	37.22	-13.26	23.96	40.00	-16.04	Peak	
2	204.1150	36.52	-14.64	21.88	43.50	-21.62	Peak	
3	323.4250	30.11	-11.00	19.11	46.00	-26.89	Peak	
4	435.9450	29.47	-8.49	20.98	46.00	-25.02	Peak	
5	548.9500	29.33	-5.38	23.95	46.00	-22.05	Peak	
6 *	796.7849	35.27	-0.88	34.39	46.00	-11.61	Peak	

Remark: This test data is from original report BTL-FCCP-4-1602C038.

Test Mode: UNII-1/TX A Mode 5240MHz\_ANT2

**Vertical**

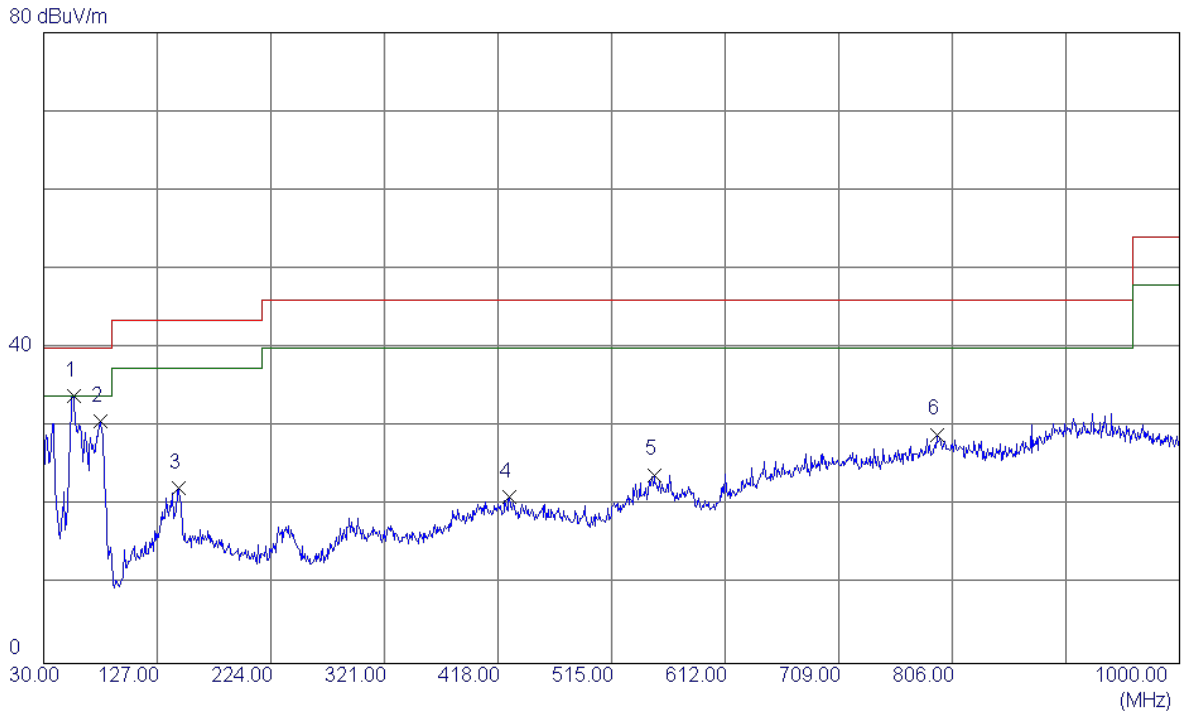

No.	Freq. MHz	Reading Level dBuV/m	Correct Factor dB	Measure ment dBuV/m	Limit dBuV/m	Margin dB	Detector	Comment
1 *	55.7050	47.18	-13.26	33.92	40.00	-6.08	Peak	
2	78.5000	46.79	-16.14	30.65	40.00	-9.35	Peak	
3	144.9450	35.67	-13.38	22.29	43.50	-21.21	Peak	
4	428.1850	29.63	-8.44	21.19	46.00	-24.81	Peak	
5	551.3750	29.27	-5.35	23.92	46.00	-22.08	Peak	
6	792.9050	30.09	-1.05	29.04	46.00	-16.96	Peak	

Remark: This test data is from original report BTL-FCCP-4-1602C038.

Test Mode: UNII-1/TX A Mode 5240MHz\_ANT2

Horizontal

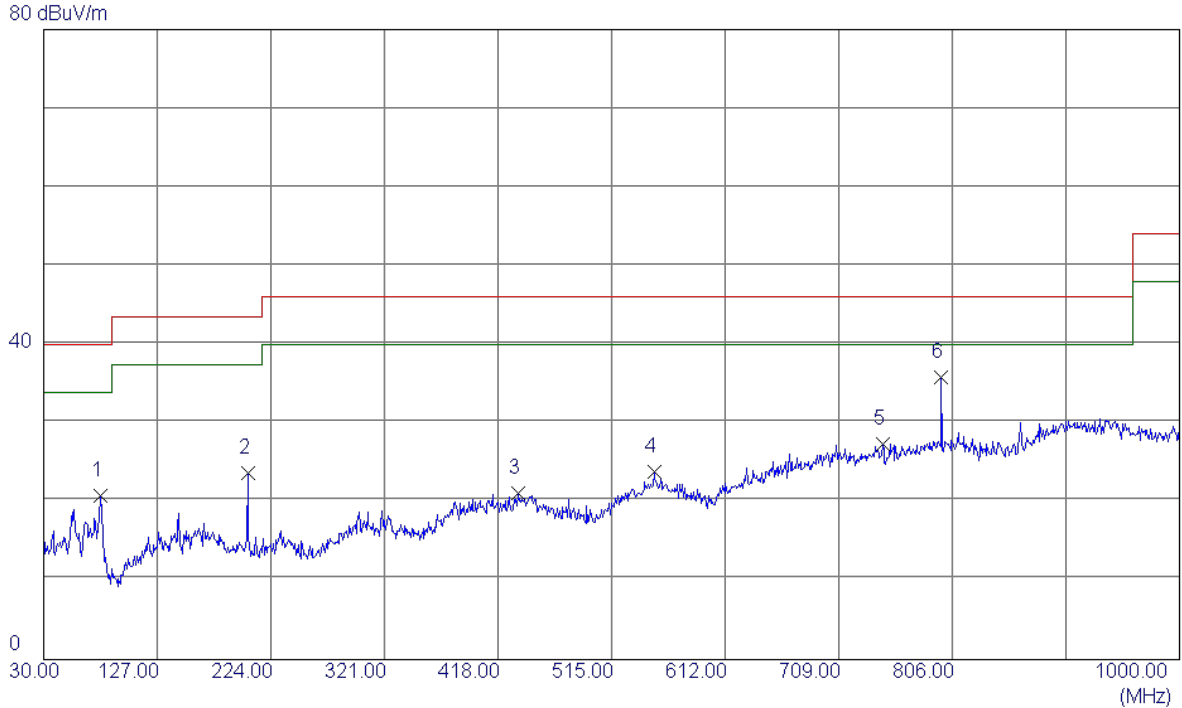

No.	Freq. MHz	Reading Level dBuV/m	Correct Factor dB	Measure ment dBuV/m	Limit dBuV/m	Margin dB	Detector	Comment
1	78.9850	36.82	-16.09	20.73	40.00	-19.27	Peak	
2	204.1150	38.35	-14.64	23.71	43.50	-19.79	Peak	
3	434.9750	29.59	-8.48	21.11	46.00	-24.89	Peak	
4	551.3750	29.16	-5.35	23.81	46.00	-22.19	Peak	
5	746.3449	30.34	-2.93	27.41	46.00	-18.59	Peak	
6 *	796.7849	36.72	-0.88	35.84	46.00	-10.16	Peak	

Remark: This test data is from original report BTL-FCCP-4-1602C038.

Test Mode: UNII-2A/TX A Mode 5260MHz\_ANT2

**Vertical**

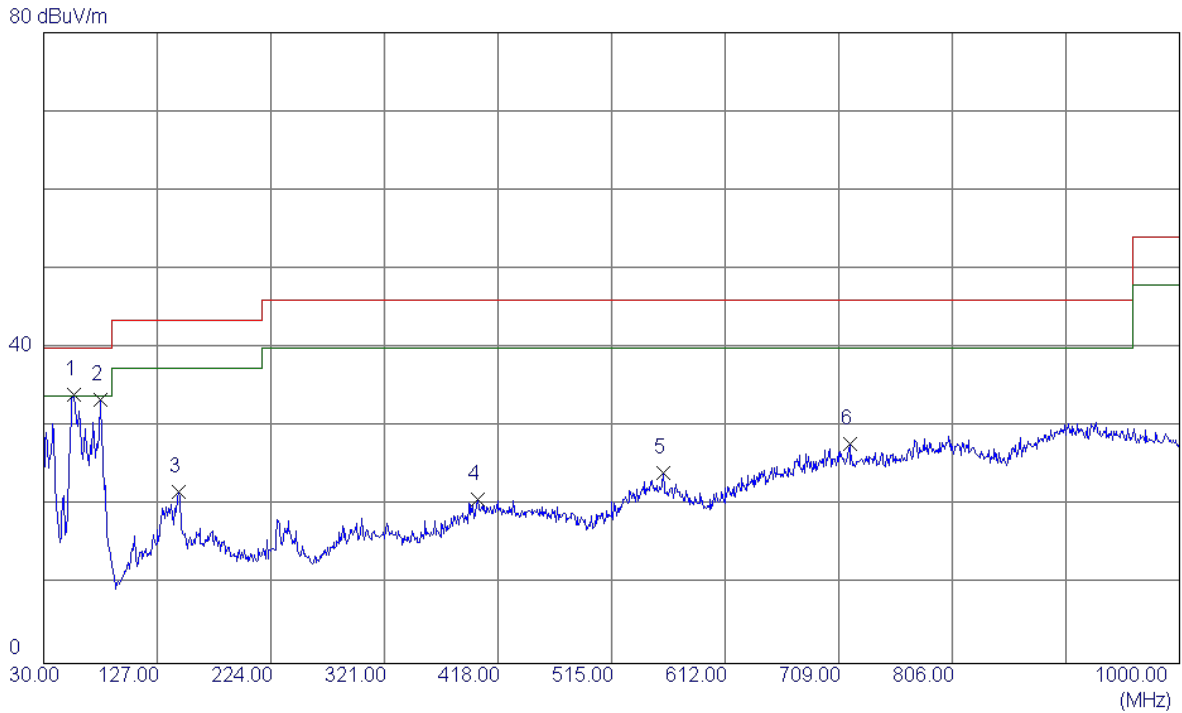

No.	Freq. MHz	Reading Level dBuV/m	Correct Factor dB	Measure ment dBuV/m	Limit dBuV/m	Margin dB	Detector	Comment
1 *	56.1900	47.34	-13.26	34.08	40.00	-5.92	Peak	
2	78.0150	49.59	-16.20	33.39	40.00	-6.61	Peak	
3	145.4299	35.17	-13.34	21.83	43.50	-21.67	Peak	
4	400.5400	29.11	-8.27	20.84	46.00	-25.16	Peak	
5	559.1350	29.94	-5.75	24.19	46.00	-21.81	Peak	
6	718.2150	30.86	-2.98	27.88	46.00	-18.12	Peak	

Remark: This test data is from original report BTL-FCCP-4-1602C038.

Test Mode: UNII-2A/TX A Mode 5260MHz\_ANT2

**Horizontal**

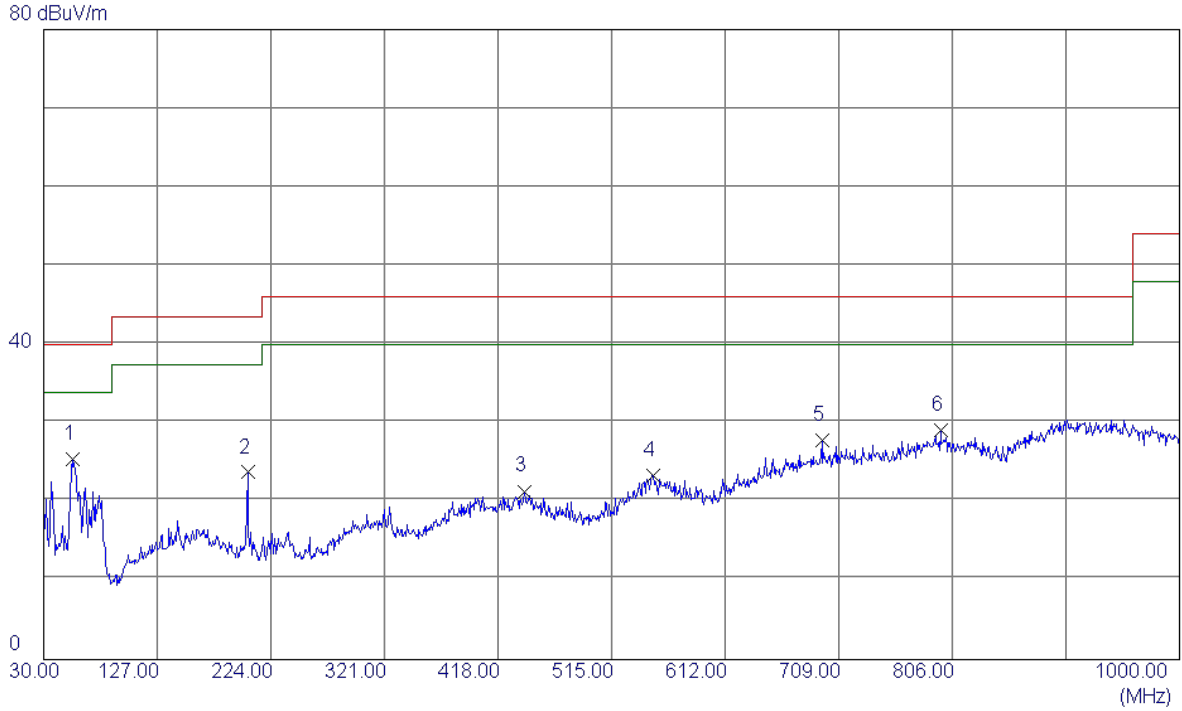

No.	Freq. MHz	Reading Level dBuV/m	Correct Factor dB	Measure ment dBuV/m	Limit dBuV/m	Margin dB	Detector	Comment
1 *	54.7350	38.86	-13.41	25.45	40.00	-14.55	Peak	
2	204.1150	38.40	-14.64	23.76	43.50	-19.74	Peak	
3	440.7950	29.88	-8.52	21.36	46.00	-24.64	Peak	
4	550.8900	28.65	-5.32	23.33	46.00	-22.67	Peak	
5	694.9350	31.00	-3.22	27.78	46.00	-18.22	Peak	
6	795.8150	30.08	-0.92	29.16	46.00	-16.84	Peak	

Remark: This test data is from original report BTL-FCCP-4-1602C038.



Test Mode: UNII-2A/TX A Mode 5300MHz\_ANT2

**Vertical**

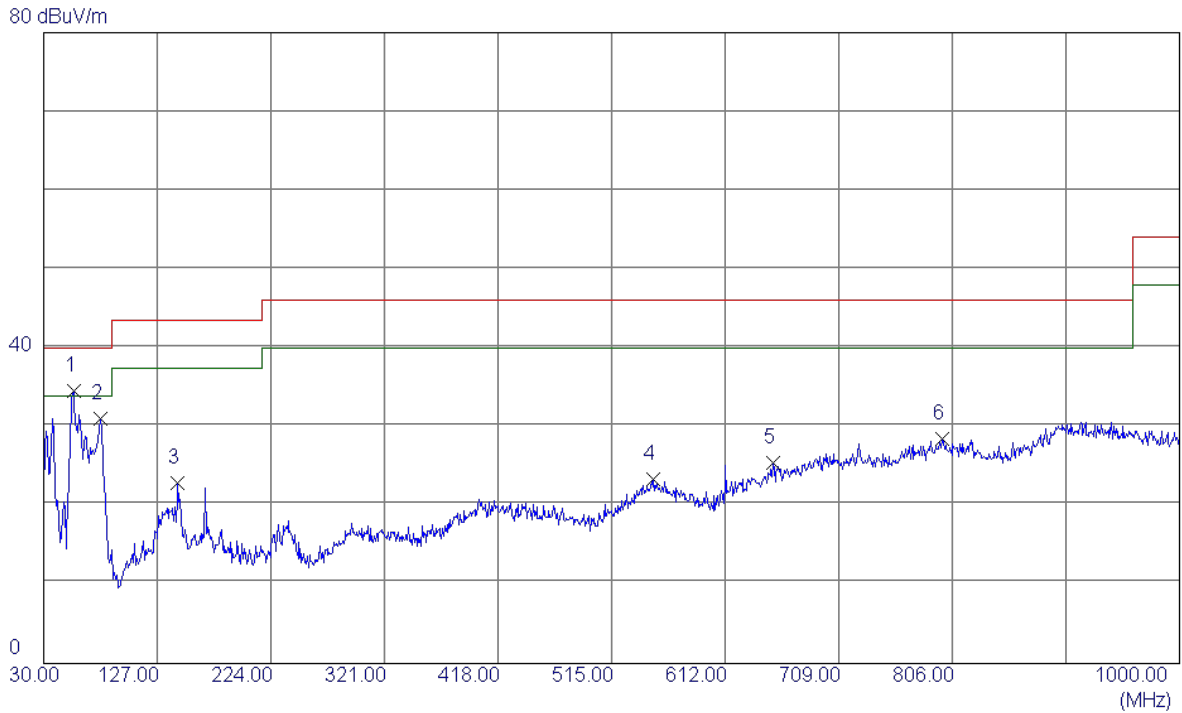

No.	Freq. MHz	Reading Level dBuV/m	Correct Factor dB	Measure ment dBuV/m	Limit dBuV/m	Margin dB	Detector	Comment
1 *	55.7050	47.84	-13.26	34.58	40.00	-5.42	Peak	
2	78.0150	47.22	-16.20	31.02	40.00	-8.98	Peak	
3	144.4600	36.28	-13.42	22.86	43.50	-20.64	Peak	
4	550.8900	28.66	-5.32	23.34	46.00	-22.66	Peak	
5	653.2250	30.35	-4.91	25.44	46.00	-20.56	Peak	
6	797.7550	29.39	-0.84	28.55	46.00	-17.45	Peak	

Remark: This test data is from original report BTL-FCCP-4-1602C038.

Test Mode: UNII-2A/TX A Mode 5300MHz\_ANT2

Horizontal

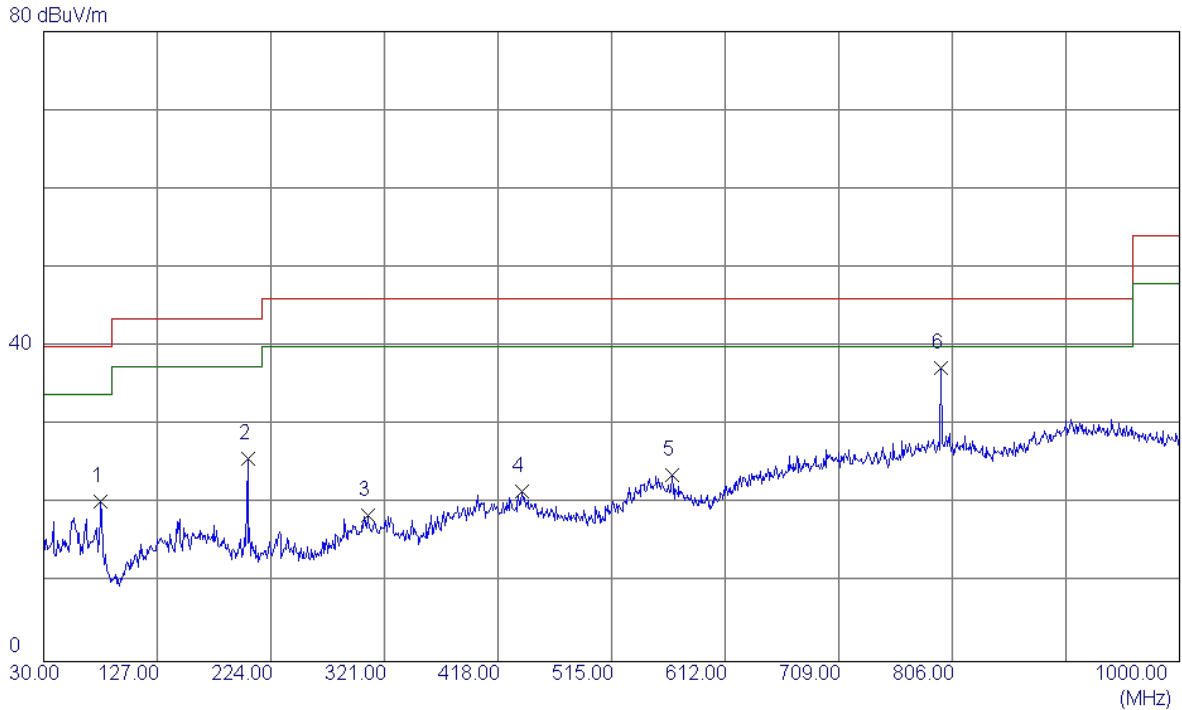

No.	Freq. MHz	Reading Level dBuV/m	Correct Factor dB	Measure ment dBuV/m	Limit dBuV/m	Margin dB	Detector	Comment
1	78.5000	36.46	-16.14	20.32	40.00	-19.68	Peak	
2	204.1150	40.35	-14.64	25.71	43.50	-17.79	Peak	
3	306.9350	29.11	-10.62	18.49	46.00	-27.51	Peak	
4	438.8550	30.05	-8.51	21.54	46.00	-24.46	Peak	
5	566.8950	29.85	-6.15	23.70	46.00	-22.30	Peak	
6 *	796.7849	38.10	-0.88	37.22	46.00	-8.78	Peak	

Remark: This test data is from original report BTL-FCCP-4-1602C038.

Test Mode: UNII-2A/TX A Mode 5320MHz\_ANT2

**Vertical**

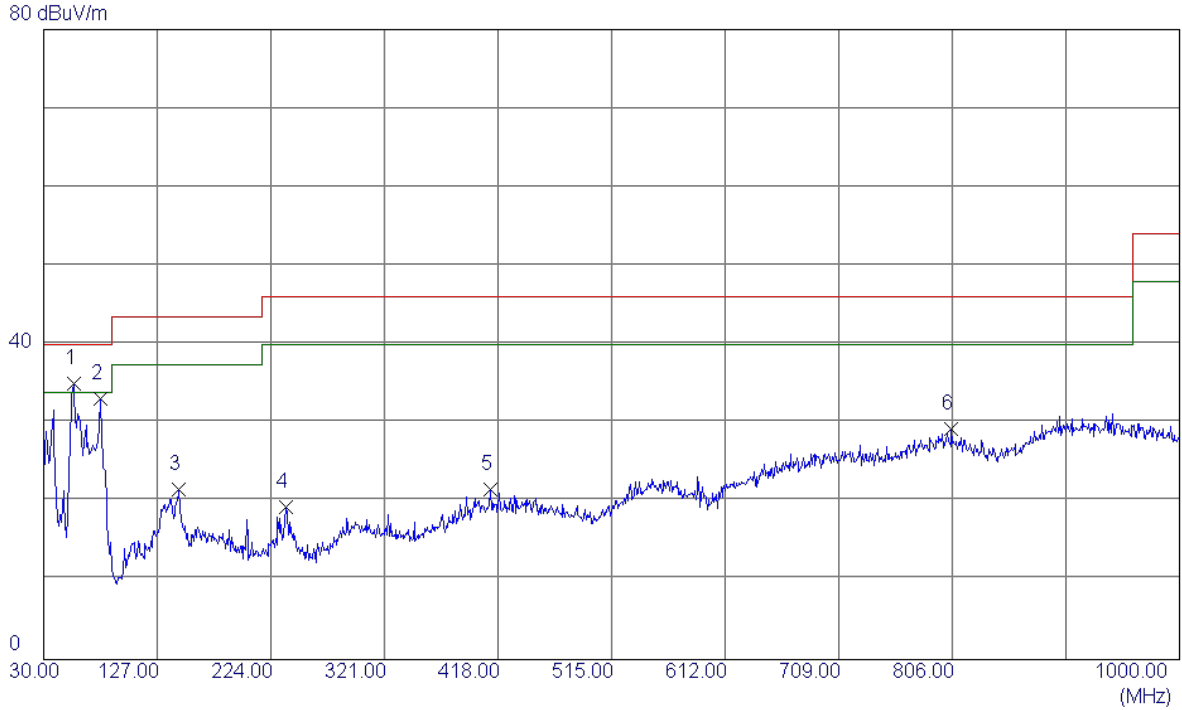

No.	Freq. MHz	Reading Level dBuV/m	Correct Factor dB	Measure ment dBuV/m	Limit dBuV/m	Margin dB	Detector	Comment
1 *	55.7050	48.37	-13.26	35.11	40.00	-4.89	Peak	
2	78.0150	49.27	-16.20	33.07	40.00	-6.93	Peak	
3	145.4299	35.00	-13.34	21.66	43.50	-21.84	Peak	
4	237.0950	33.16	-13.84	19.32	46.00	-26.68	Peak	
5	411.2100	29.91	-8.34	21.57	46.00	-24.43	Peak	
6	805.0300	30.13	-0.90	29.23	46.00	-16.77	Peak	

Remark: This test data is from original report BTL-FCCP-4-1602C038.

Test Mode: UNII-2A/TX A Mode 5320MHz\_ANT2

**Horizontal**

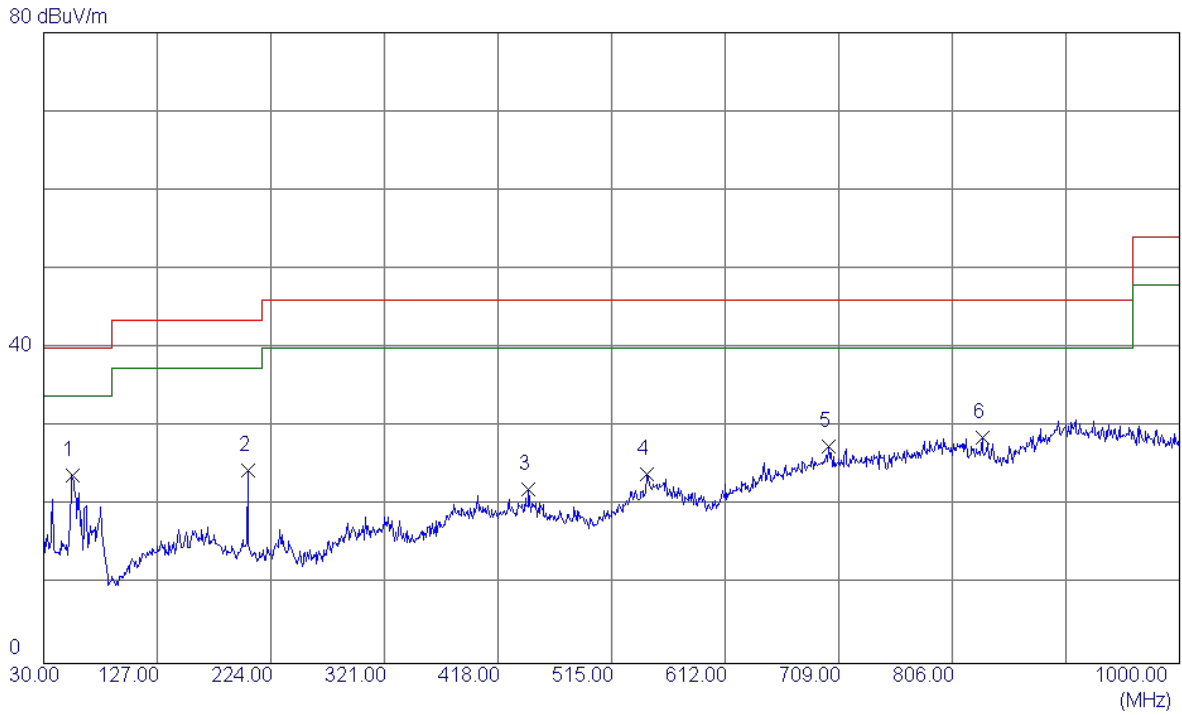

No.	Freq. MHz	Reading Level dBuV/m	Correct Factor dB	Measure ment dBuV/m	Limit dBuV/m	Margin dB	Detector	Comment
1 *	54.2500	37.35	-13.49	23.86	40.00	-16.14	Peak	
2	204.1150	39.06	-14.64	24.42	43.50	-19.08	Peak	
3	444.1900	30.58	-8.54	22.04	46.00	-23.96	Peak	
4	545.0700	29.80	-5.78	24.02	46.00	-21.98	Peak	
5	700.2700	30.49	-3.01	27.48	46.00	-18.52	Peak	
6	831.7050	30.39	-1.73	28.66	46.00	-17.34	Peak	

Remark: This test data is from original report BTL-FCCP-4-1602C038.

Test Mode: UNII-2C/TX A Mode 5500MHz\_ANT2

**Vertical**

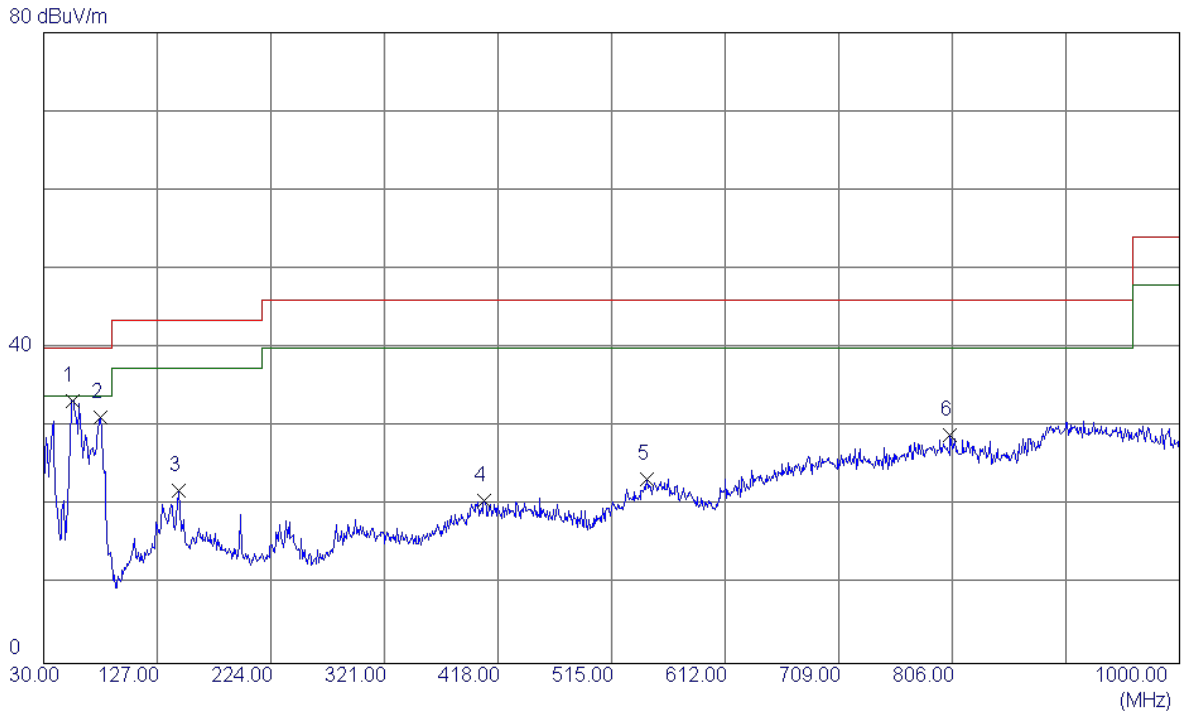

No.	Freq. MHz	Reading Level dBuV/m	Correct Factor dB	Measure ment dBuV/m	Limit dBuV/m	Margin dB	Detector	Comment
1 *	54.2500	46.77	-13.49	33.28	40.00	-6.72	Peak	
2	78.0150	47.34	-16.20	31.14	40.00	-8.86	Peak	
3	145.4299	35.33	-13.34	21.99	43.50	-21.51	Peak	
4	406.3599	29.02	-8.31	20.71	46.00	-25.29	Peak	
5	545.0700	29.16	-5.78	23.38	46.00	-22.62	Peak	
6	804.0600	29.84	-0.87	28.97	46.00	-17.03	Peak	

Remark: This test data is from original report BTL-FCCP-4-1602C038.

Test Mode: UNII-2C/TX A Mode 5500MHz\_ANT2

Horizontal

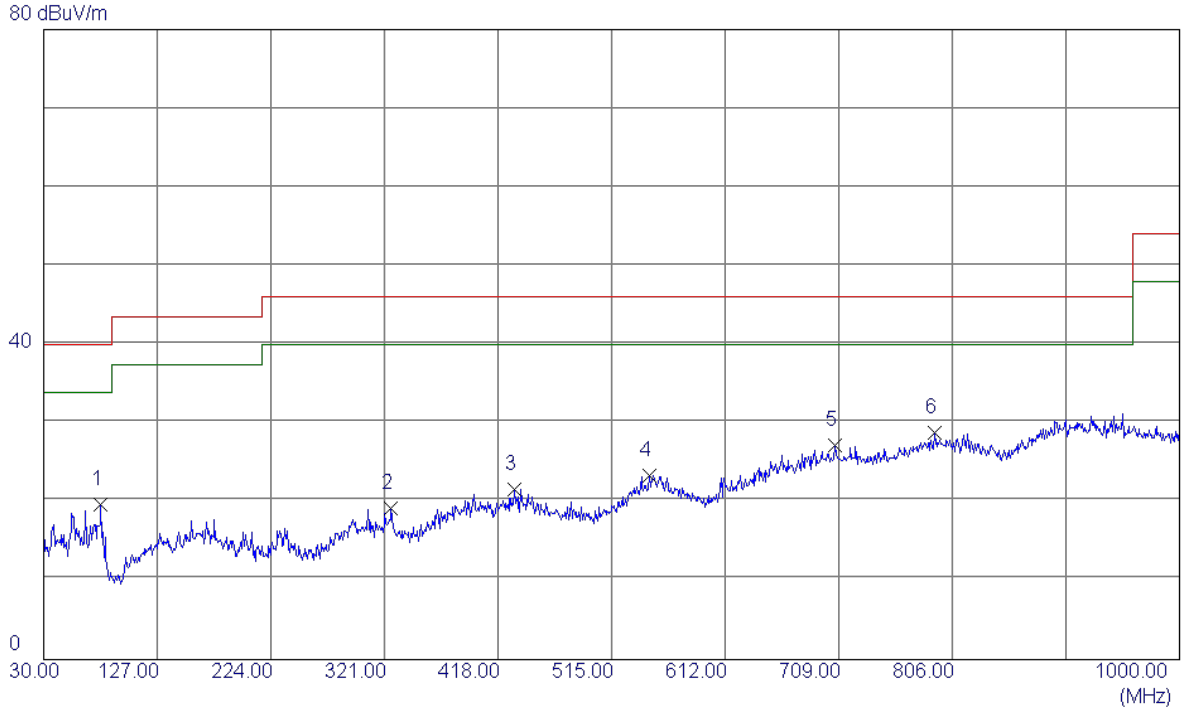

No.	Freq. MHz	Reading Level dBuV/m	Correct Factor dB	Measure ment dBuV/m	Limit dBuV/m	Margin dB	Detector	Comment
1	78.9850	35.82	-16.09	19.73	40.00	-20.27	Peak	
2	326.8200	30.25	-11.08	19.17	46.00	-26.83	Peak	
3	432.0650	30.03	-8.47	21.56	46.00	-24.44	Peak	
4	547.0100	29.01	-5.58	23.43	46.00	-22.57	Peak	
5	705.6050	30.27	-3.00	27.27	46.00	-18.73	Peak	
6 *	790.9650	29.96	-1.13	28.83	46.00	-17.17	Peak	

Remark: This test data is from original report BTL-FCCP-4-1602C038.

Test Mode: UNII-2C/TX A Mode 5580MHz\_ANT2

**Vertical**

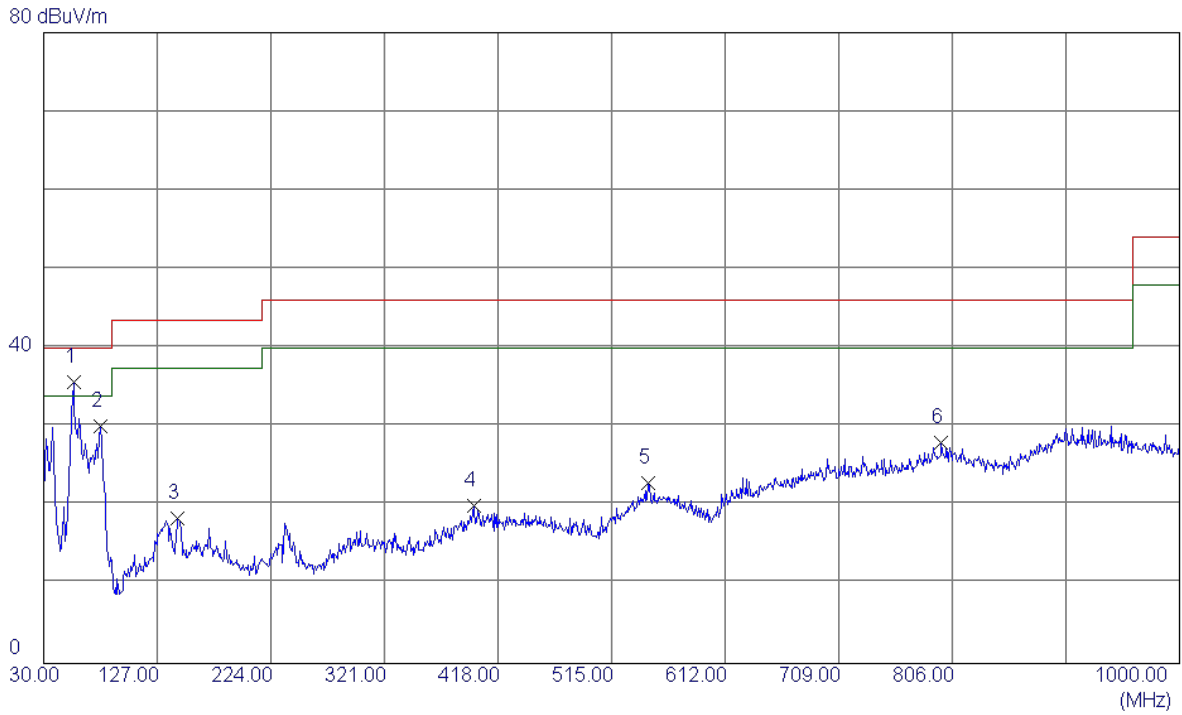

No.	Freq. MHz	Reading Level dBuV/m	Correct Factor dB	Measure ment dBuV/m	Limit dBuV/m	Margin dB	Detector	Comment
1 *	55.7050	48.92	-13.26	35.66	40.00	-4.34	Peak	
2	78.0150	46.26	-16.20	30.06	40.00	-9.94	Peak	
3	144.4600	31.81	-13.42	18.39	43.50	-25.11	Peak	
4	397.1450	28.53	-8.46	20.07	46.00	-25.93	Peak	
5	546.5250	28.45	-5.63	22.82	46.00	-23.18	Peak	
6	796.3000	28.91	-0.90	28.01	46.00	-17.99	Peak	

Remark: This test data is from original report BTL-FCCP-4-1602C038.

Test Mode: UNII-2C/TX A Mode 5580MHz\_ANT2

**Horizontal**

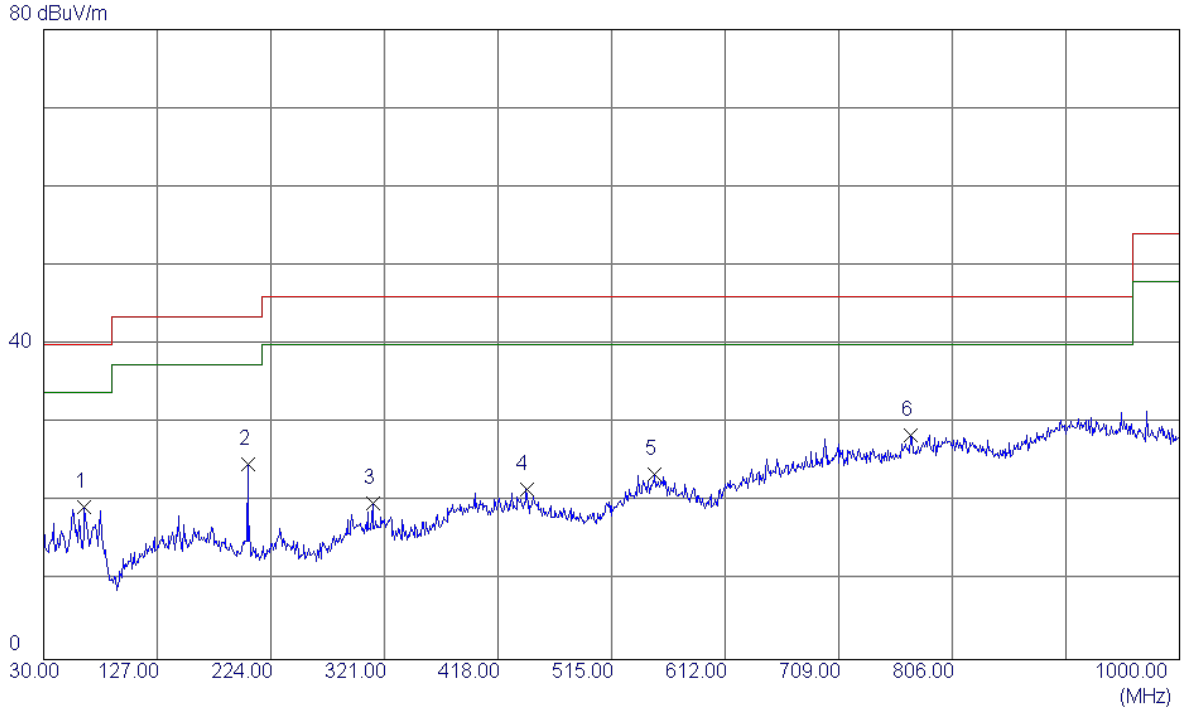

No.	Freq. MHz	Reading Level dBuV/m	Correct Factor dB	Measure ment dBuV/m	Limit dBuV/m	Margin dB	Detector	Comment
1	64.9200	34.46	-15.09	19.37	40.00	-20.63	Peak	
2	204.1150	39.40	-14.64	24.76	43.50	-18.74	Peak	
3	310.8150	30.55	-10.71	19.84	46.00	-26.16	Peak	
4	442.2500	30.11	-8.53	21.58	46.00	-24.42	Peak	
5	551.8600	28.87	-5.37	23.50	46.00	-22.50	Peak	
6 *	770.5949	30.54	-2.02	28.52	46.00	-17.48	Peak	

Remark: This test data is from original report BTL-FCCP-4-1602C038.



Test Mode: UNII-2C/TX A Mode 5700MHz\_ANT2

**Vertical**

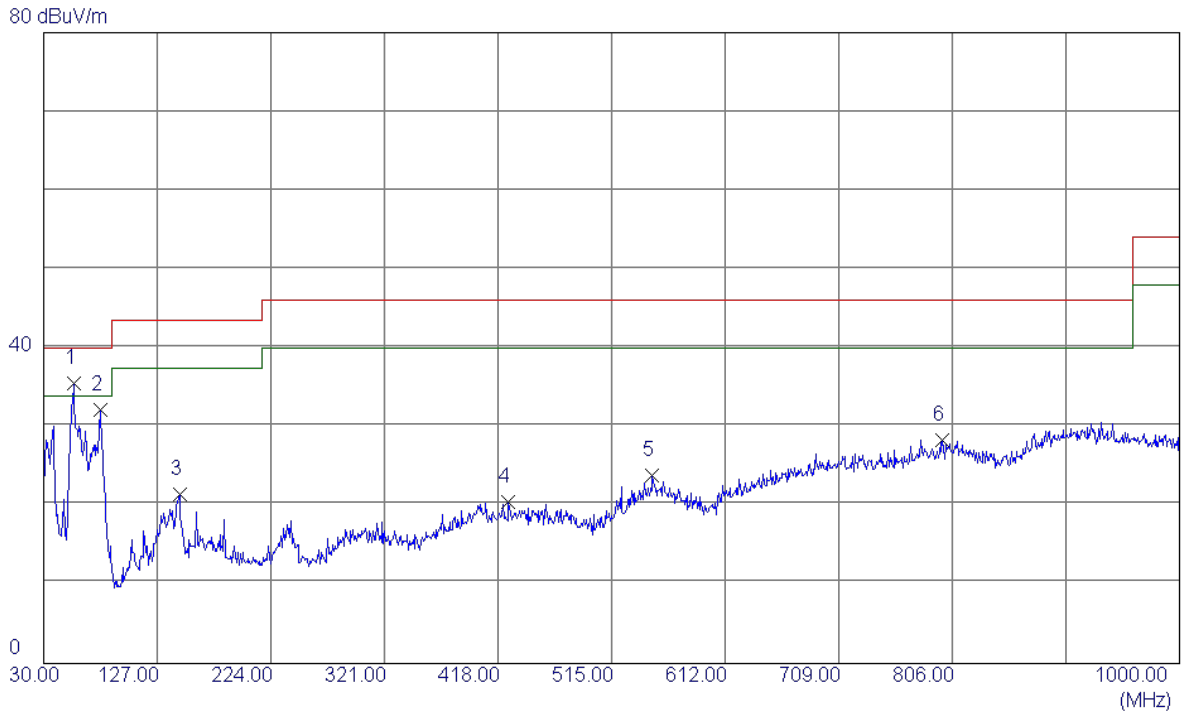

No.	Freq. MHz	Reading Level dBuV/m	Correct Factor dB	Measure ment dBuV/m	Limit dBuV/m	Margin dB	Detector	Comment
1 *	55.7050	48.82	-13.26	35.56	40.00	-4.44	Peak	
2	78.0150	48.30	-16.20	32.10	40.00	-7.90	Peak	
3	145.9149	34.78	-13.30	21.48	43.50	-22.02	Peak	
4	426.7300	28.93	-8.43	20.50	46.00	-25.50	Peak	
5	549.9200	29.09	-5.28	23.81	46.00	-22.19	Peak	
6	797.2700	29.19	-0.86	28.33	46.00	-17.67	Peak	

Remark: This test data is from original report BTL-FCCP-4-1602C038.

Test Mode: UNII-2C/TX A Mode 5700MHz\_ANT2

**Horizontal**

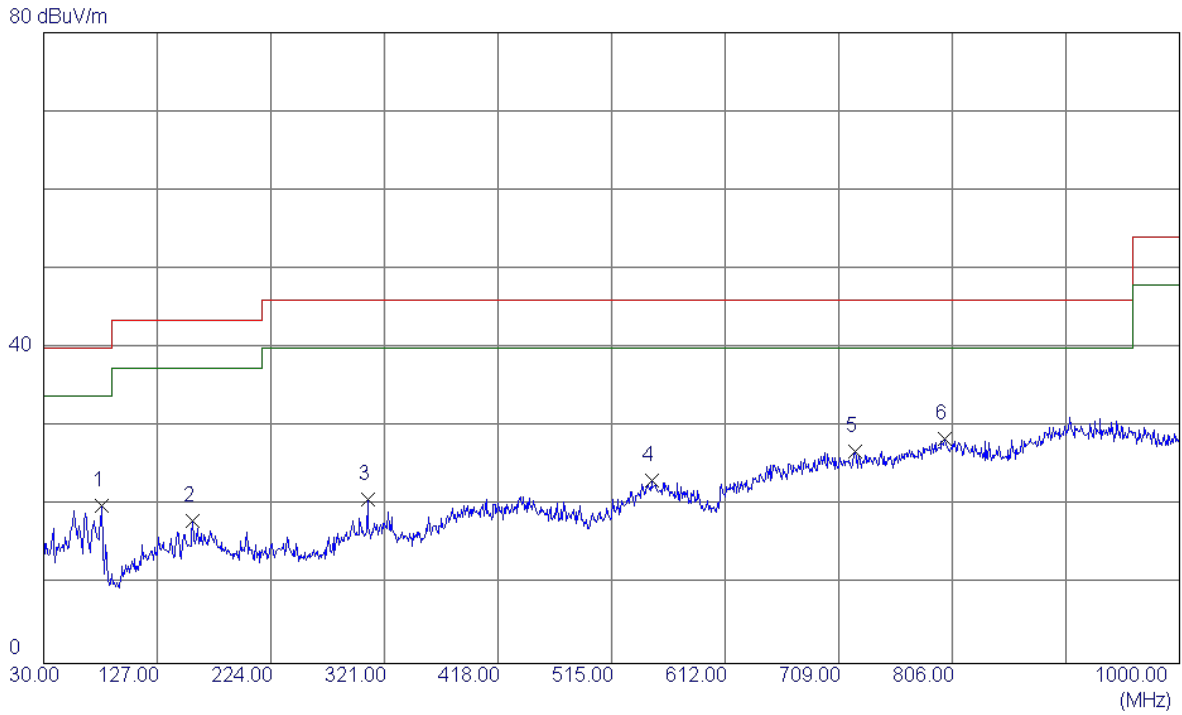

No.	Freq. MHz	Reading Level dBuV/m	Correct Factor dB	Measure ment dBuV/m	Limit dBuV/m	Margin dB	Detector	Comment
1	79.4700	35.99	-16.04	19.95	40.00	-20.05	Peak	
2	157.5549	30.51	-12.38	18.13	43.50	-25.37	Peak	
3	306.9350	31.35	-10.62	20.73	46.00	-25.27	Peak	
4	549.4350	28.57	-5.33	23.24	46.00	-22.76	Peak	
5	722.5800	29.84	-2.97	26.87	46.00	-19.13	Peak	
6 *	799.2100	29.20	-0.77	28.43	46.00	-17.57	Peak	

Remark: This test data is from original report BTL-FCCP-4-1602C038.

Test Mode: UNII-3/TX A Mode 5745MHz\_ANT2

**Vertical**

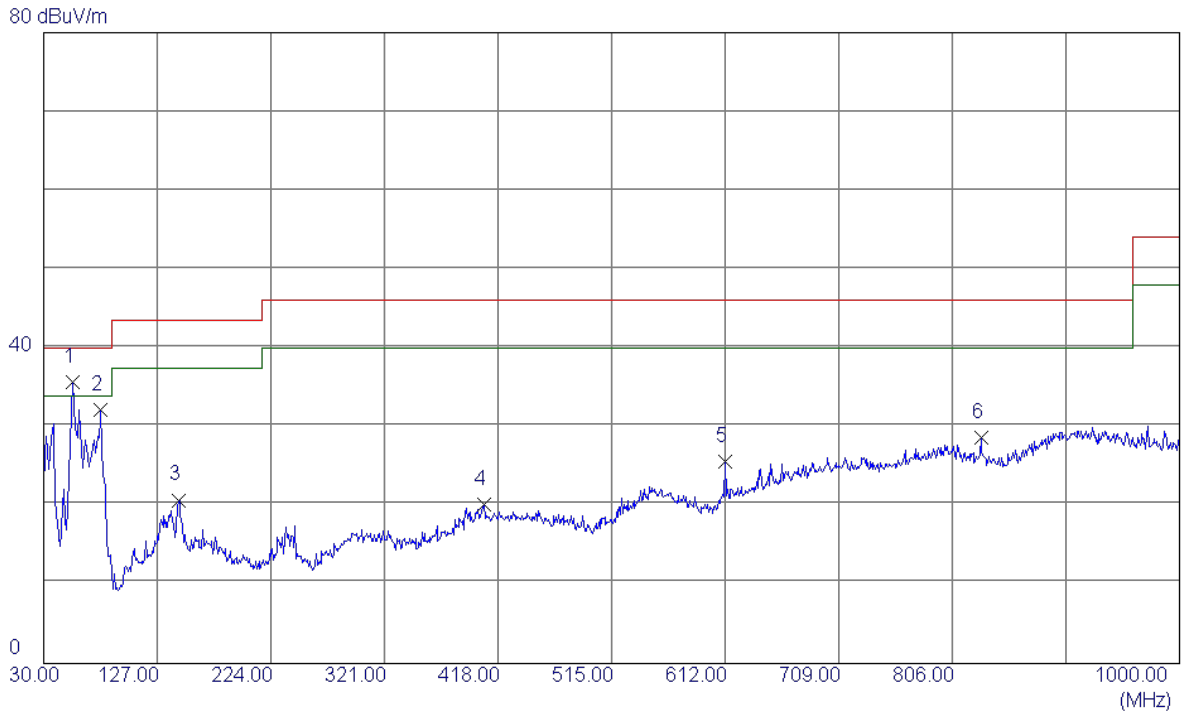

No.	Freq. MHz	Reading Level dBuV/m	Correct Factor dB	Measure ment dBuV/m	Limit dBuV/m	Margin dB	Detector	Comment
1 *	54.7350	49.02	-13.41	35.61	40.00	-4.39	Peak	
2	78.5000	48.28	-16.14	32.14	40.00	-7.86	Peak	
3	144.9450	34.10	-13.38	20.72	43.50	-22.78	Peak	
4	405.8750	28.48	-8.31	20.17	46.00	-25.83	Peak	
5	612.0000	32.77	-7.19	25.58	46.00	-20.42	Peak	
6	830.7350	30.35	-1.70	28.65	46.00	-17.35	Peak	

Remark: This test data is from original report BTL-FCCP-4-1602C038.

Test Mode: UNII-3/TX A Mode 5745MHz\_ANT2

**Horizontal**

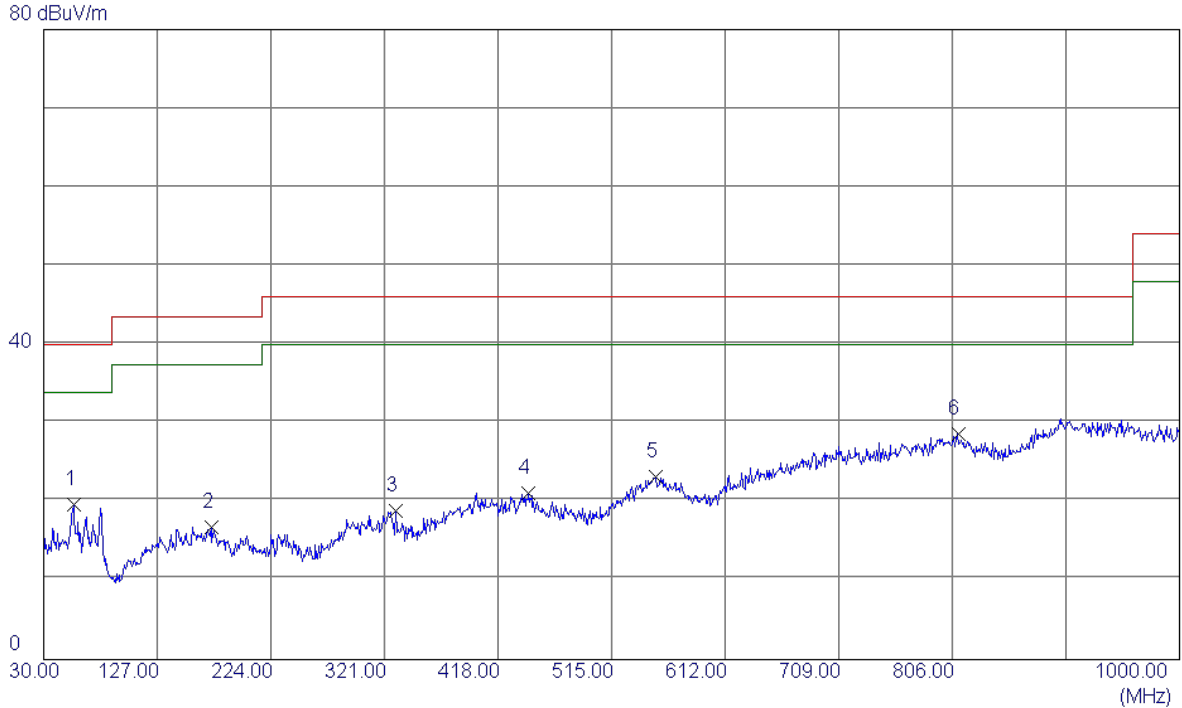

No.	Freq. MHz	Reading Level dBuV/m	Correct Factor dB	Measure ment dBuV/m	Limit dBuV/m	Margin dB	Detector	Comment
1	55.7050	32.94	-13.26	19.68	40.00	-20.32	Peak	
2	173.5600	29.39	-12.52	16.87	43.50	-26.63	Peak	
3	330.7000	29.99	-11.17	18.82	46.00	-27.18	Peak	
4	444.1900	29.73	-8.54	21.19	46.00	-24.81	Peak	
5	552.3449	28.57	-5.40	23.17	46.00	-22.83	Peak	
6 *	810.8500	29.67	-1.08	28.59	46.00	-17.41	Peak	

Remark: This test data is from original report BTL-FCCP-4-1602C038.

Test Mode: UNII-3/TX A Mode 5785MHz\_ANT2

**Vertical**

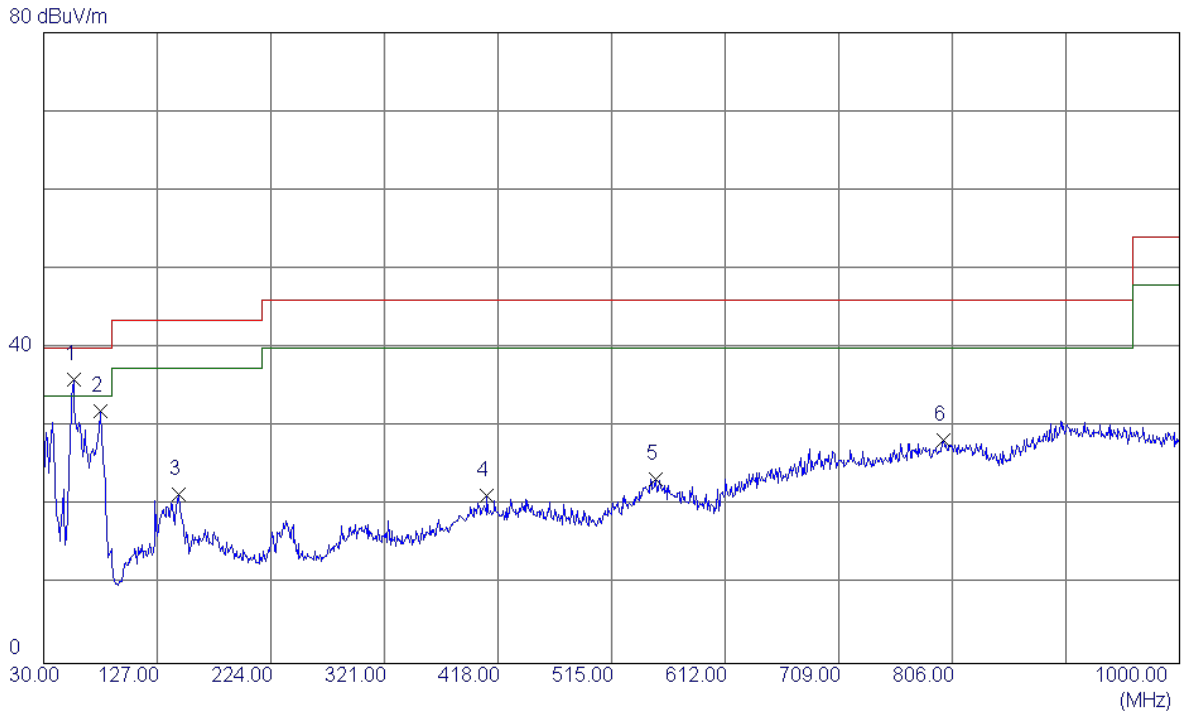

No.	Freq. MHz	Reading Level dBuV/m	Correct Factor dB	Measure ment dBuV/m	Limit dBuV/m	Margin dB	Detector	Comment
1 *	55.7050	49.24	-13.26	35.98	40.00	-4.02	Peak	
2	78.0150	48.14	-16.20	31.94	40.00	-8.06	Peak	
3	144.9450	34.78	-13.38	21.40	43.50	-22.10	Peak	
4	408.3000	29.58	-8.32	21.26	46.00	-24.74	Peak	
5	552.8300	28.74	-5.42	23.32	46.00	-22.68	Peak	
6	798.2400	29.16	-0.82	28.34	46.00	-17.66	Peak	

Remark: This test data is from original report BTL-FCCP-4-1602C038.

Test Mode: UNII-3/TX A Mode 5785MHz\_ANT2

Horizontal

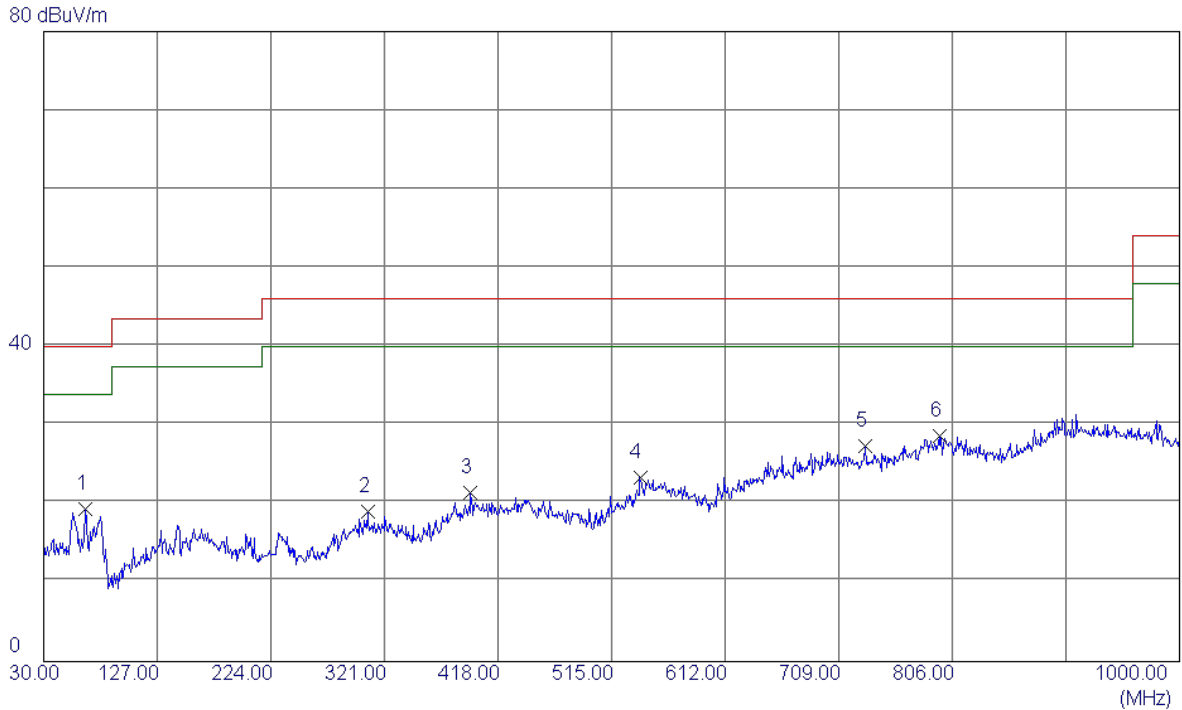

No.	Freq. MHz	Reading Level dBuV/m	Correct Factor dB	Measure ment dBuV/m	Limit dBuV/m	Margin dB	Detector	Comment
1	65.4050	34.63	-15.22	19.41	40.00	-20.59	Peak	
2	306.9350	29.69	-10.62	19.07	46.00	-26.93	Peak	
3	394.7200	30.04	-8.62	21.42	46.00	-24.58	Peak	
4	539.2500	29.78	-6.37	23.41	46.00	-22.59	Peak	
5	731.7950	30.35	-2.96	27.39	46.00	-18.61	Peak	
6 *	794.8449	29.65	-0.97	28.68	46.00	-17.32	Peak	

Remark: This test data is from original report BTL-FCCP-4-1602C038.

Test Mode: UNII-3/TX A Mode 5825MHz\_ANT2

Vertical

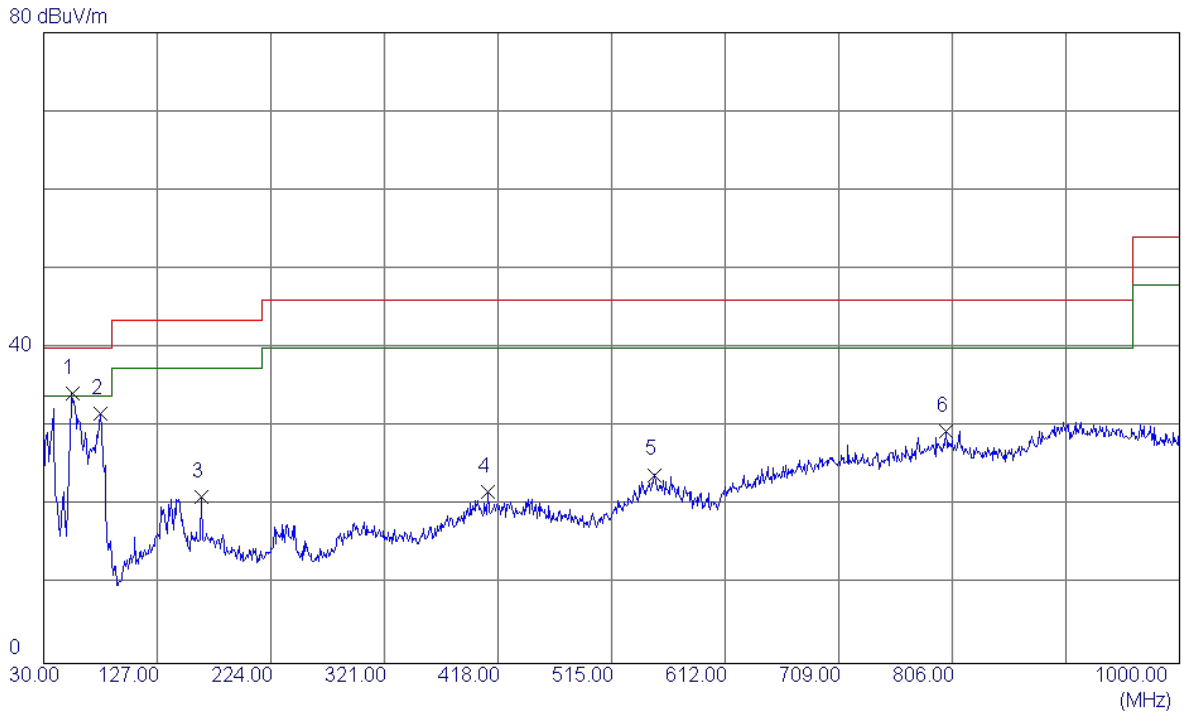

No.	Freq. MHz	Reading Level dBuV/m	Correct Factor dB	Measure ment dBuV/m	Limit dBuV/m	Margin dB	Detector	Comment
1 *	54.2500	47.75	-13.49	34.26	40.00	-5.74	Peak	
2	78.9850	47.76	-16.09	31.67	40.00	-8.33	Peak	
3	164.8300	33.40	-12.25	21.15	43.50	-22.35	Peak	
4	409.7550	30.10	-8.33	21.77	46.00	-24.23	Peak	
5	551.8600	29.29	-5.37	23.92	46.00	-22.08	Peak	
6	800.1800	30.23	-0.75	29.48	46.00	-16.52	Peak	

Remark: This test data is from original report BTL-FCCP-4-1602C038.

Test Mode: UNII-3/TX A Mode 5825MHz\_ANT2

**Horizontal**

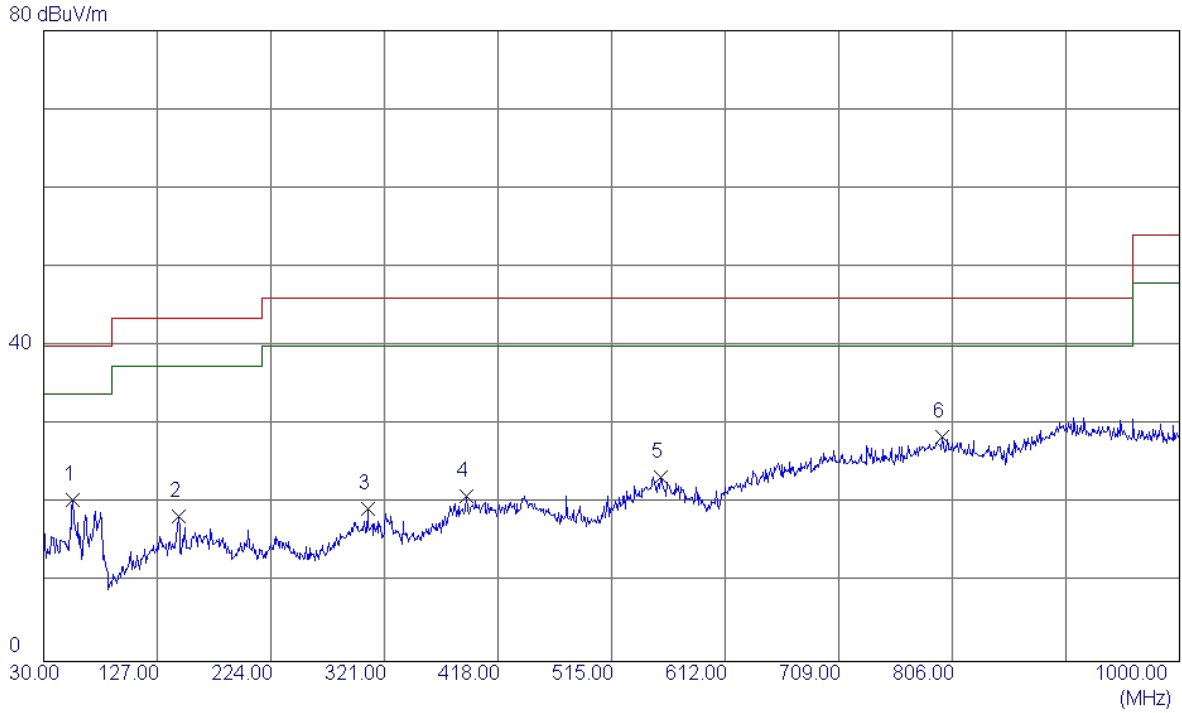

No.	Freq. MHz	Reading Level dBuV/m	Correct Factor dB	Measure ment dBuV/m	Limit dBuV/m	Margin dB	Detector	Comment
1	55.2200	33.88	-13.33	20.55	40.00	-19.45	Peak	
2	144.9450	31.76	-13.38	18.38	43.50	-25.12	Peak	
3	306.9350	29.96	-10.62	19.34	46.00	-26.66	Peak	
4	390.8400	29.90	-8.88	21.02	46.00	-24.98	Peak	
5	557.1950	28.99	-5.65	23.34	46.00	-22.66	Peak	
6 *	797.2700	29.35	-0.86	28.49	46.00	-17.51	Peak	

Remark: This test data is from original report BTL-FCCP-4-1602C038.



## APPENDIX D - RADIATED EMISSION (ABOVE 1000MHZ)

Orthogonal Axis:	X
Test Mode:	UNII-1/ TX A Mode 5180MHz _ANT1

**Vertical**

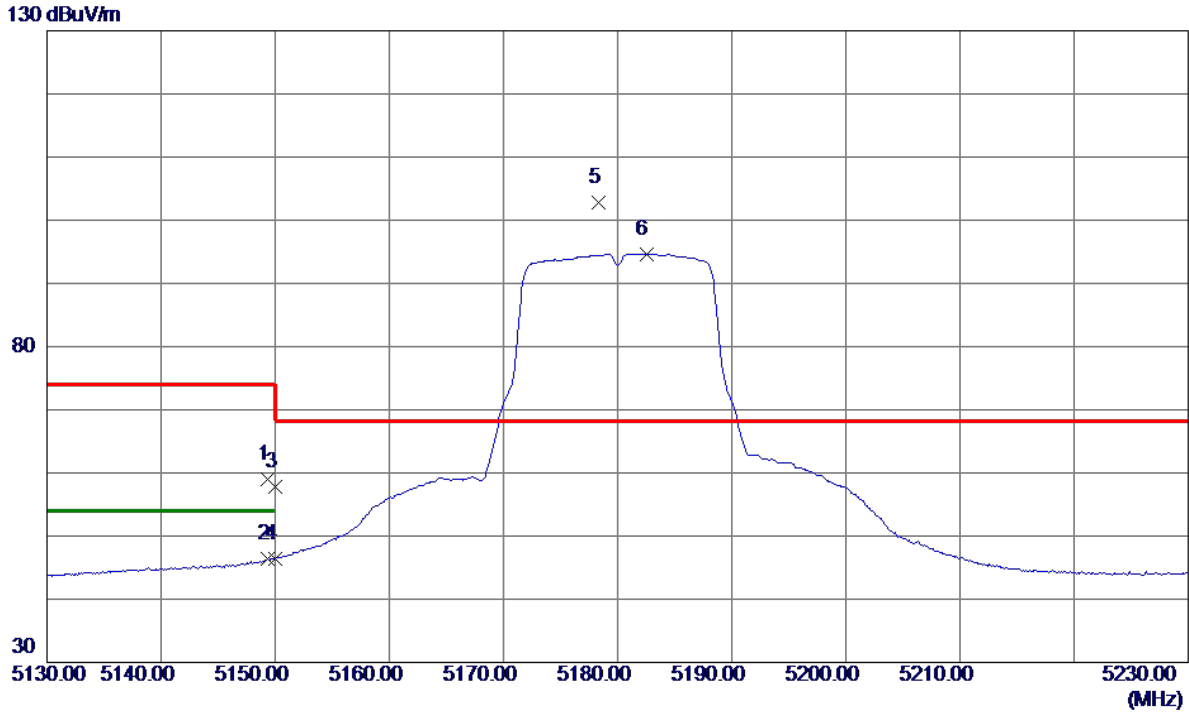

No.	Freq. MHz	Reading Level dBuV/m	Correct Factor dB	Measure ment dBuV/m	Limit dBuV/m	Margin dB	Detector	Comment
1	5149.3000	40.86	18.19	59.05	74.00	-14.95	Peak	
2	5149.3000	28.15	18.19	46.34	54.00	-7.66	AVG	
3	5150.0000	39.58	18.19	57.77	74.00	-16.23	Peak	
4	5150.0000	28.28	18.19	46.47	54.00	-7.53	AVG	
5 *	5178.3000	84.36	18.37	102.73	68.30	34.43	Peak	No Limit
6	5182.5000	76.30	18.39	94.69	999.00	-904.31	AVG	No Limit

Orthogonal Axis:	X
Test Mode:	UNII-1/ TX A Mode 5180MHz_ANT1

**Vertical**

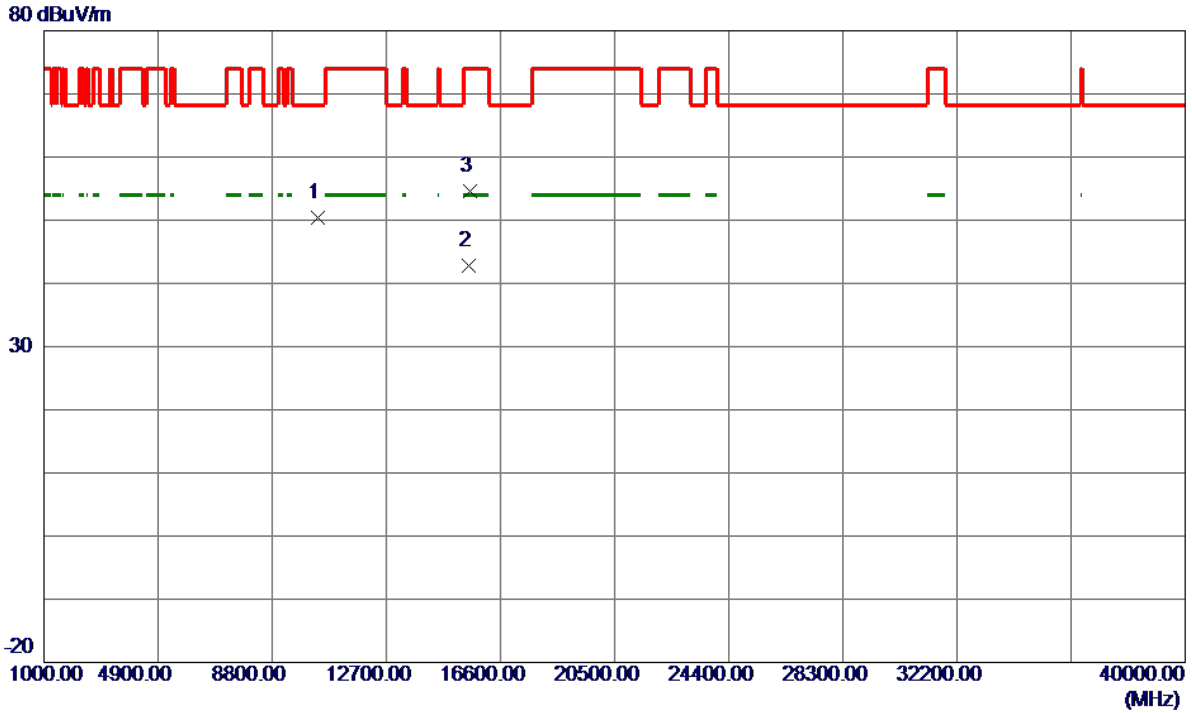

No.	Freq. MHz	Reading Level dBuV/m	Correct Factor dB	Measure ment dBuV/m	Limit dBuV/m	Margin dB	Detector	Comment
1	10358.2200	34.02	16.33	50.35	68.30	-17.95	Peak	
2 *	15537.9800	19.49	23.27	42.76	54.00	-11.24	AVG	
3	15538.9000	31.37	23.27	54.64	74.00	-19.36	Peak	

Orthogonal Axis:	X
Test Mode:	UNII-1/ TX A Mode 5180MHz_ANT1

Horizontal

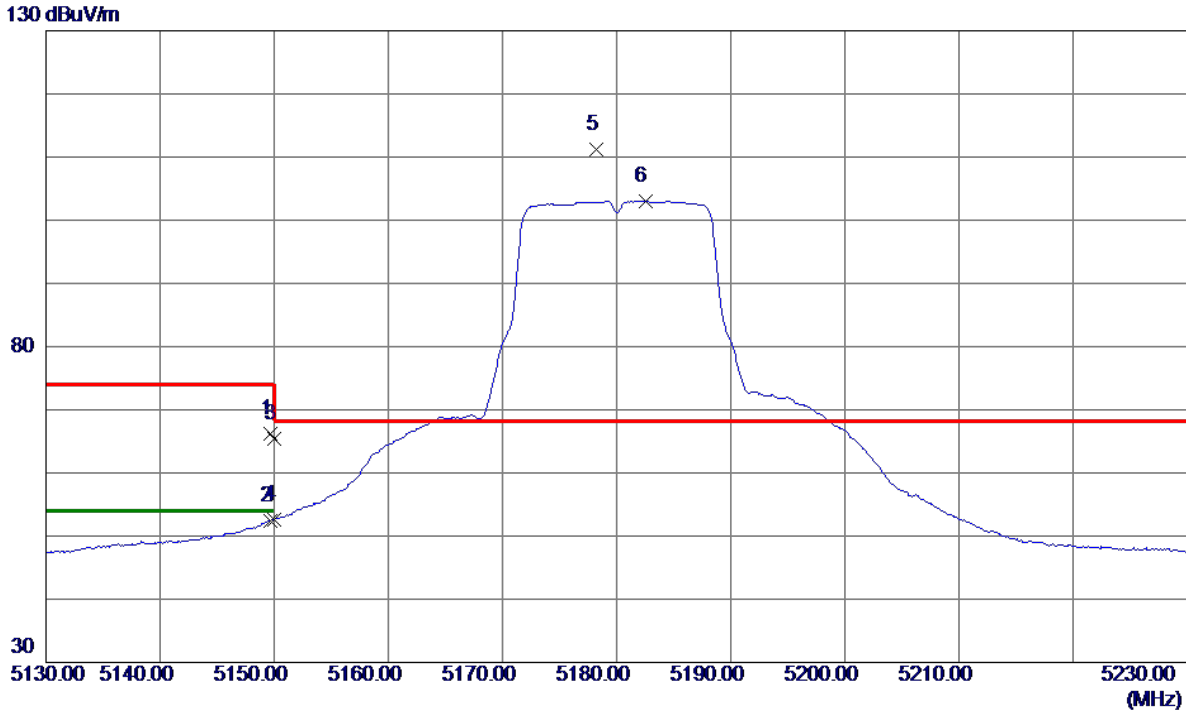

No.	Freq. MHz	Reading Level dBuV/m	Correct Factor dB	Measure ment dBuV/m	Limit dBuV/m	Margin dB	Detector	Comment
1	5149.7000	48.04	18.19	66.23	74.00	-7.77	Peak	
2	5149.7000	34.28	18.19	52.47	54.00	-1.53	AVG	
3	5150.0000	47.26	18.19	65.45	74.00	-8.55	Peak	
4	5150.0000	34.50	18.19	52.69	54.00	-1.31	AVG	
5 *	5178.2000	92.81	18.36	111.17	68.30	42.87	Peak	No Limit
6	5182.5000	84.63	18.39	103.02	999.00	-895.98	AVG	No Limit

Orthogonal Axis:	X
Test Mode:	UNII-1/ TX A Mode 5180MHz_ANT1

**Horizontal**

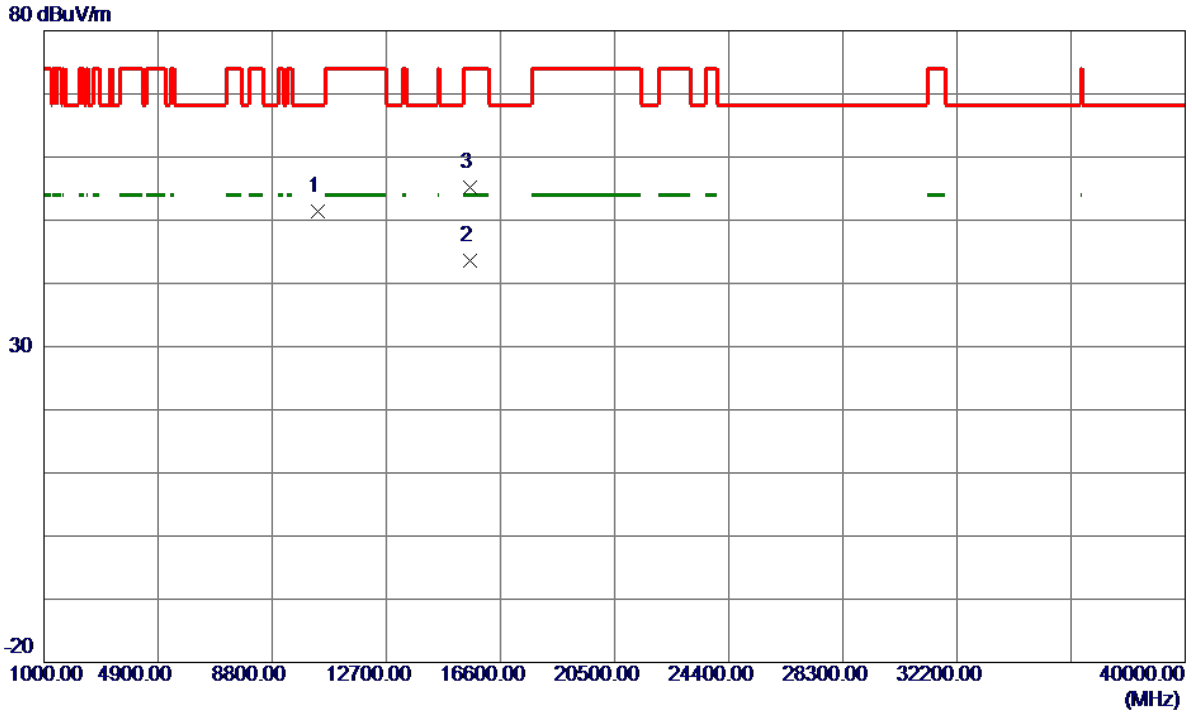

No.	Freq. MHz	Reading Level dBuV/m	Correct Factor dB	Measure ment dBuV/m	Limit dBuV/m	Margin dB	Detector	Comment
1	10363.3600	34.99	16.34	51.33	68.30	-16.97	Peak	
2 *	15544.8400	20.42	23.27	43.69	54.00	-10.31	AVG	
3	15547.0000	31.84	23.27	55.11	74.00	-18.89	Peak	

Orthogonal Axis:	X
Test Mode:	UNII-1/ TX A Mode 5180MHz_ANT2

**Vertical**

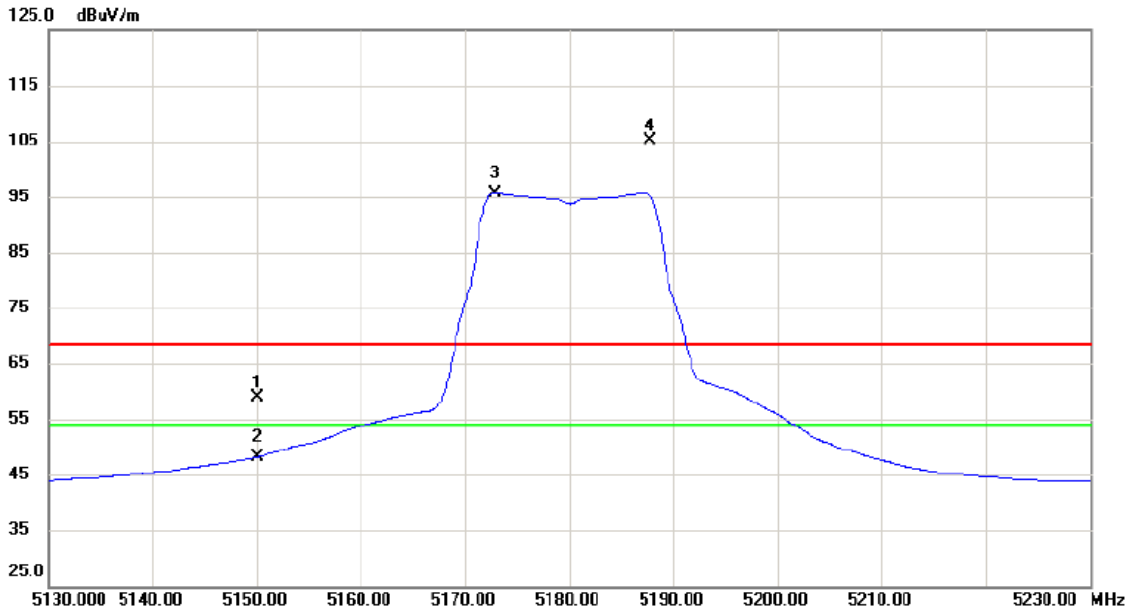

No.	Mk.	Freq. MHz	Reading Level dBuV	Correct Factor dB	Measure- ment dBuV/m	Limit dBuV/m	Margin dB	Detector	Comment
1		5150.000	18.43	40.40	58.83	68.30	-9.47	peak	
2		5150.000	7.75	40.40	48.15	54.00	-5.85	AVG	
3	*	5172.850	55.23	40.48	95.71	54.00	41.71	AVG	NO LIMIT
4	X	5187.800	64.71	40.53	105.24	68.30	36.94	peak	NO LIMIT

Remark: This test data is from original report BTL-FCCP-4-1602C038.

Orthogonal Axis:	X
Test Mode:	UNII-1/ TX A Mode 5180MHz_ANT2

**Vertical**

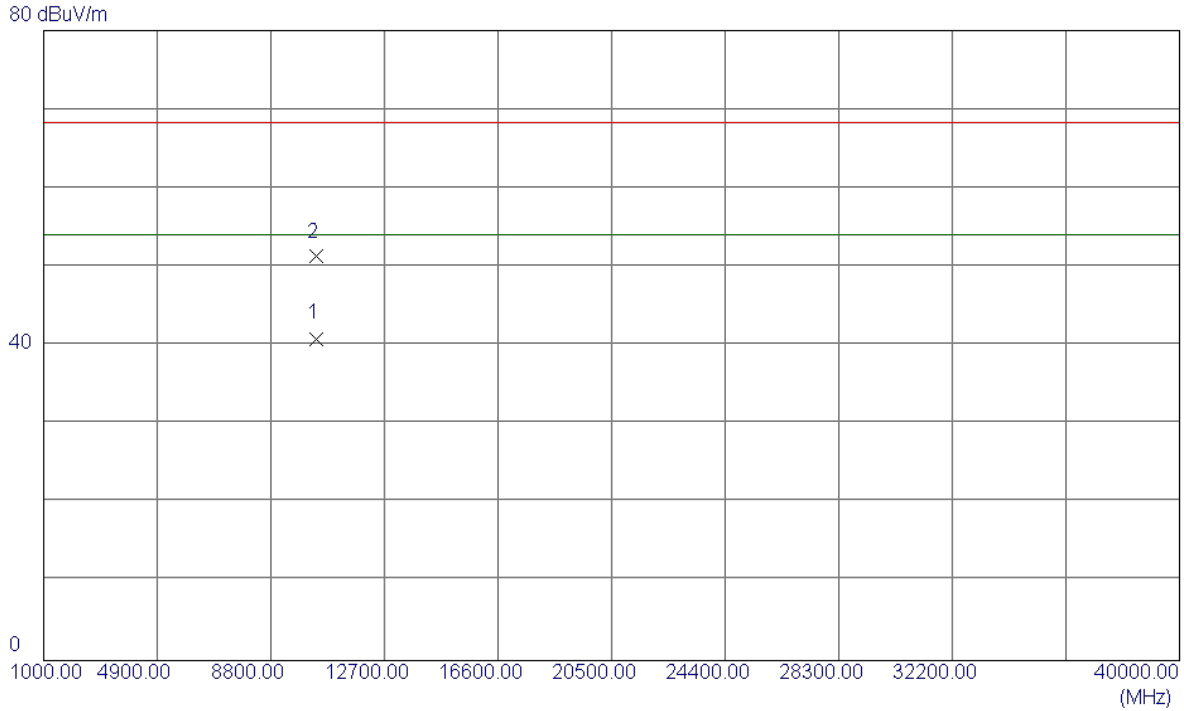

No.	Freq. MHz	Reading Level dBuV/m	Correct Factor dB	Measure ment dBuV/m	Limit dBuV/m	Margin dB	Detector	Comment
1 *	10360.3000	26.76	14.12	40.88	54.00	-13.12	AVG	
2	10360.5000	37.16	14.12	51.28	68.30	-17.02	Peak	

Remark: This test data is from original report BTL-FCCP-4-1602C038.

Orthogonal Axis:	X
Test Mode:	UNII-1/ TX A Mode 5180MHz_ANT2

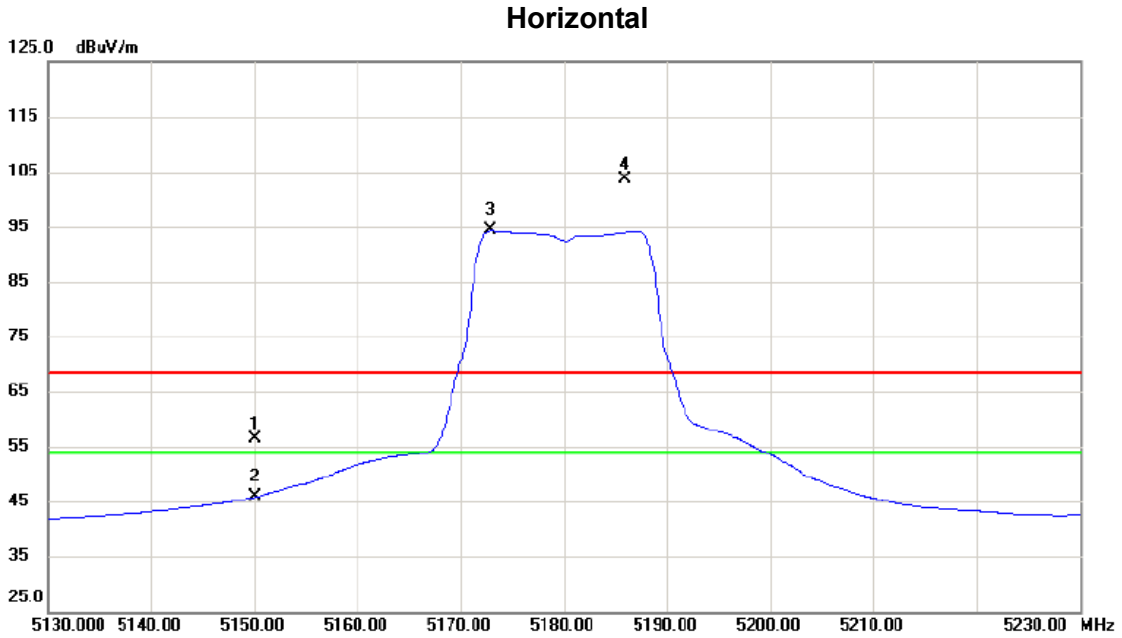

No.	Mk.	Freq. MHz	Reading Level dBuV	Correct Factor dB	Measure- ment dBuV/m	Limit dBuV/m	Margin dB	Detector	Comment
1		5150.000	15.95	40.40	56.35	68.30	-11.95	peak	
2		5150.000	5.40	40.40	45.80	54.00	-8.20	AVG	
3	*	5172.900	53.79	40.48	94.27	54.00	40.27	AVG	NO LIMIT
4	X	5185.950	63.09	40.53	103.62	68.30	35.32	peak	NO LIMIT

Remark: This test data is from original report BTL-FCCP-4-1602C038.



Orthogonal Axis:	X
Test Mode:	UNII-1/ TX A Mode 5180MHz_ANT2

**Horizontal**

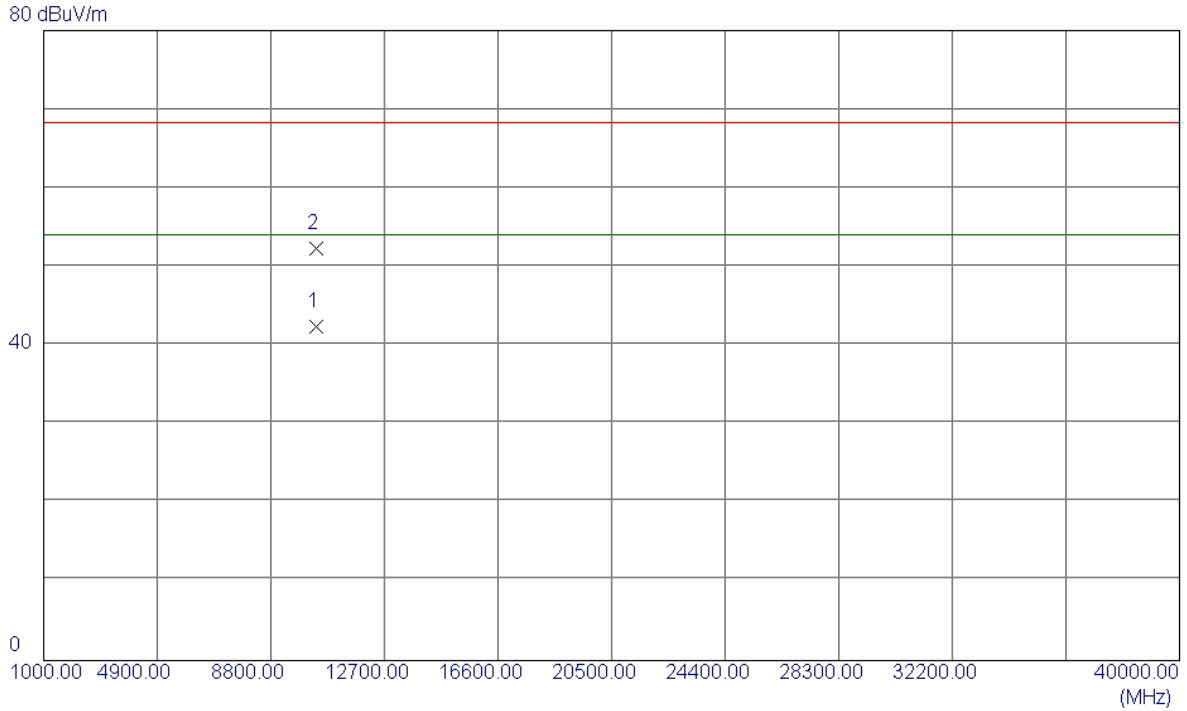

No.	Freq. MHz	Reading Level dBuV/m	Correct Factor dB	Measure ment dBuV/m	Limit dBuV/m	Margin dB	Detector	Comment
1 *	10360.1900	28.25	14.12	42.37	54.00	-11.63	AVG	
2	10362.3200	38.18	14.13	52.31	68.30	-15.99	Peak	

Remark: This test data is from original report BTL-FCCP-4-1602C038.

Orthogonal Axis:	X
Test Mode:	UNII-1/ TX A Mode 5200MHz_ANT1

**Vertical**

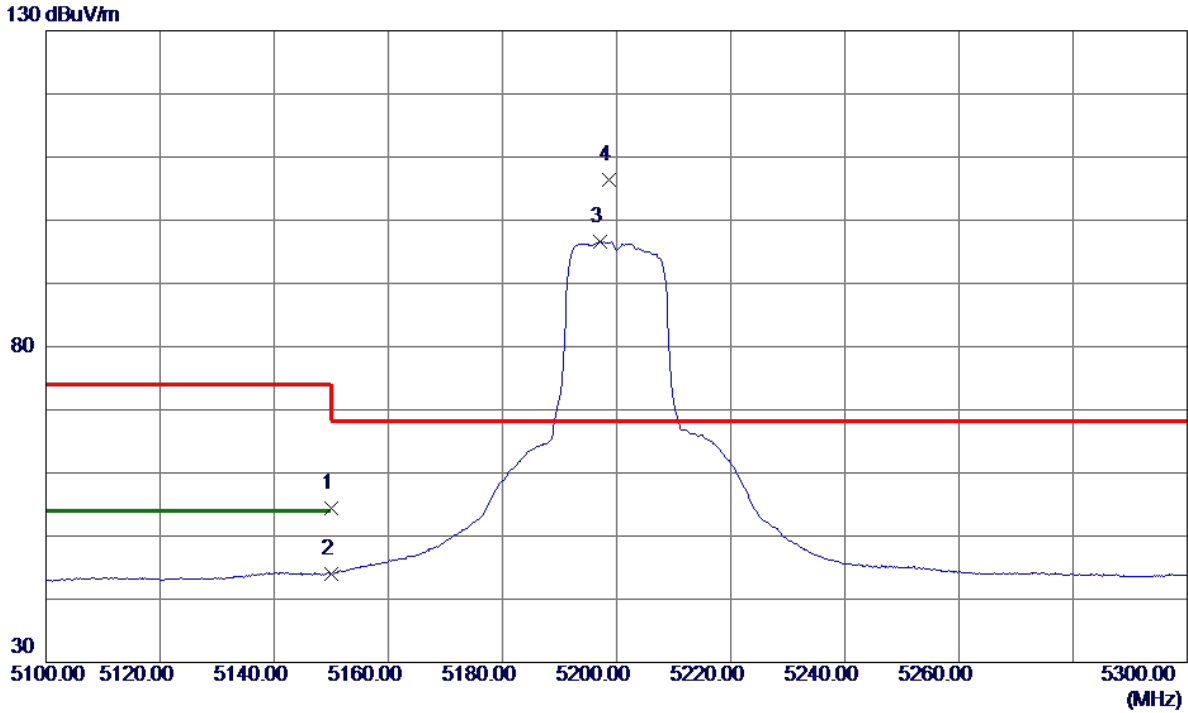

No.	Freq. MHz	Reading Level dBuV/m	Correct Factor dB	Measure ment dBuV/m	Limit dBuV/m	Margin dB	Detector	Comment
1	5150.0000	36.17	18.19	54.36	74.00	-19.64	Peak	
2	5150.0000	25.84	18.19	44.03	54.00	-9.97	AVG	
3	5197.2000	78.14	18.48	96.62	999.00	-902.38	AVG	No Limit
4 *	5198.6000	87.92	18.49	106.41	68.30	38.11	Peak	No Limit

Orthogonal Axis:	X
Test Mode:	UNII-1/ TX A Mode 5200MHz_ANT1

**Vertical**

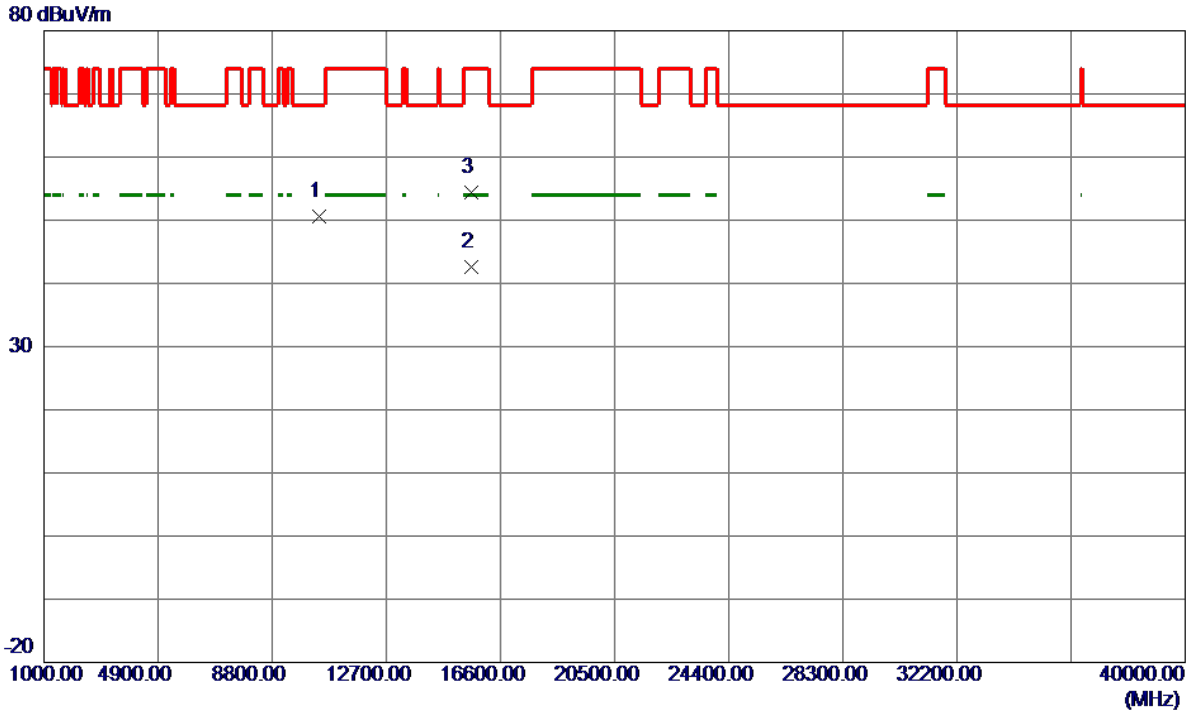

No.	Freq. MHz	Reading Level dBuV/m	Correct Factor dB	Measure ment dBuV/m	Limit dBuV/m	Margin dB	Detector	Comment
1	10409.9800	34.09	16.46	50.55	68.30	-17.75	Peak	
2 *	15597.4600	19.39	23.30	42.69	54.00	-11.31	AVG	
3	15601.0800	31.15	23.30	54.45	74.00	-19.55	Peak	

Orthogonal Axis:	X
Test Mode:	UNII-1/ TX A Mode 5200MHz_ANT1

### Horizontal

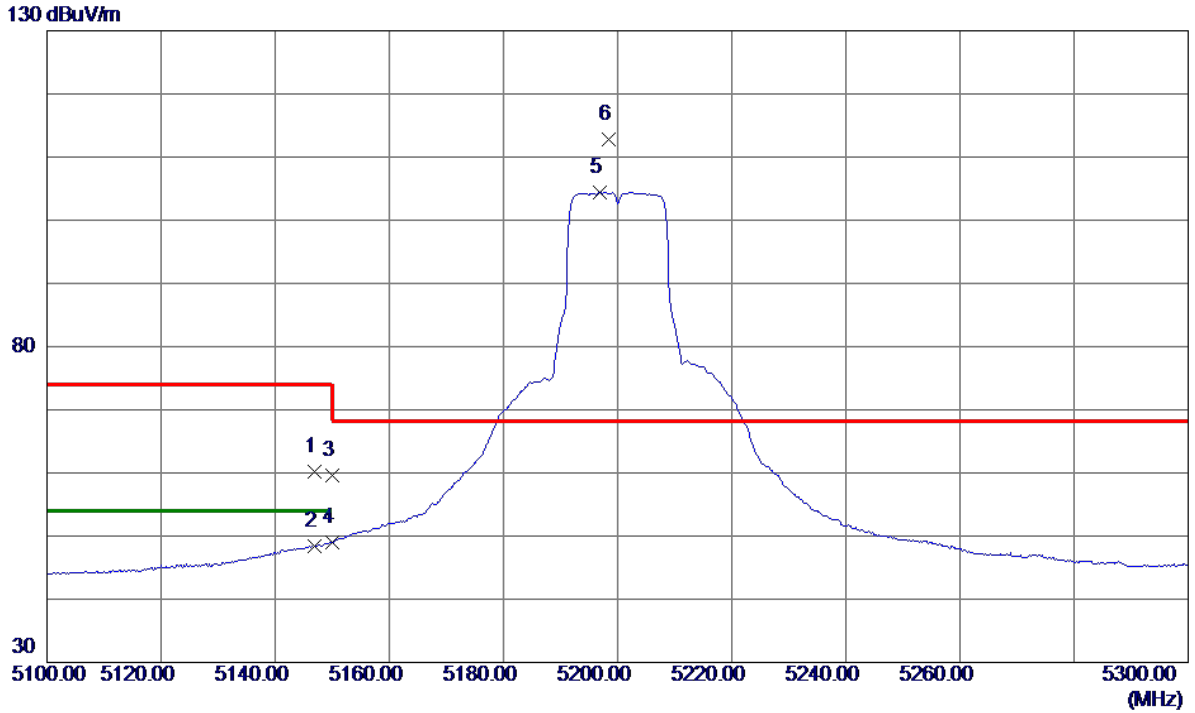

No.	Freq. MHz	Reading Level dBuV/m	Correct Factor dB	Measure ment dBuV/m	Limit dBuV/m	Margin dB	Detector	Comment
1	5146.8000	42.00	18.18	60.18	74.00	-13.82	Peak	
2	5146.8000	30.14	18.18	48.32	54.00	-5.68	AVG	
3	5150.0000	41.34	18.19	59.53	74.00	-14.47	Peak	
4	5150.0000	30.76	18.19	48.95	54.00	-5.05	AVG	
5	5196.8000	85.94	18.48	104.42	999.00	-894.58	AVG	No Limit
6 *	5198.4000	94.32	18.49	112.81	68.30	44.51	Peak	No Limit

Orthogonal Axis:	X
Test Mode:	UNII-1/ TX A Mode 5200MHz_ANT1

**Horizontal**

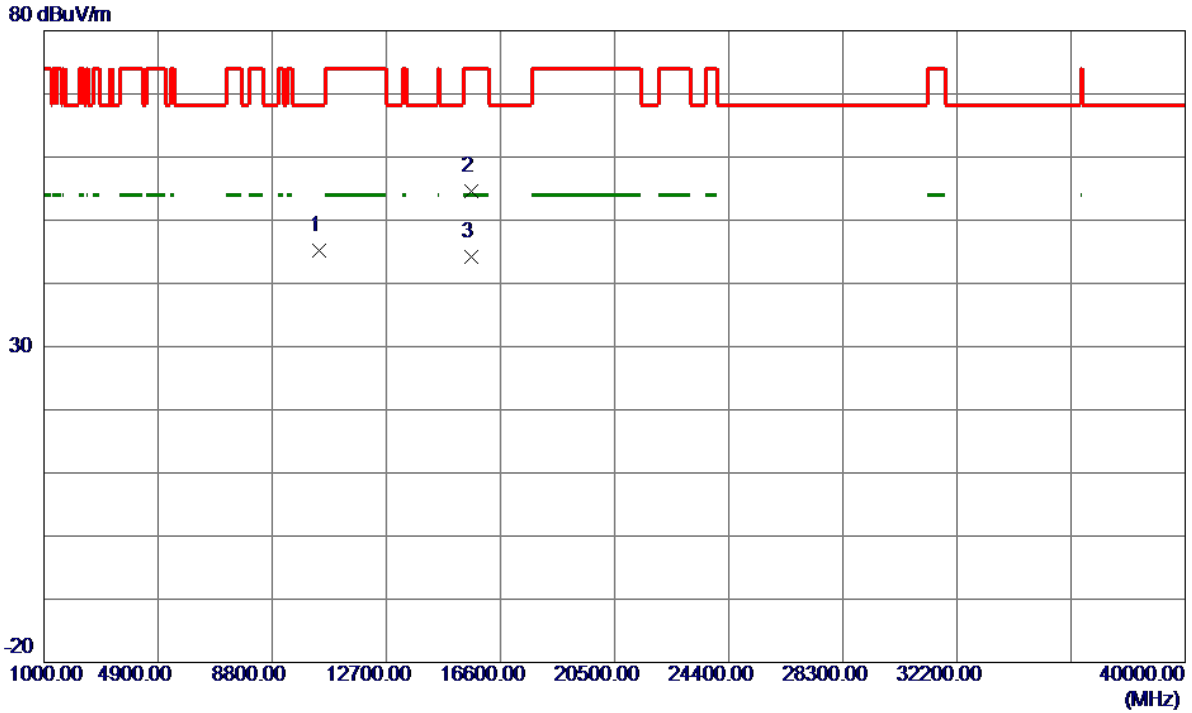

No.	Freq. MHz	Reading Level dBuV/m	Correct Factor dB	Measure ment dBuV/m	Limit dBuV/m	Margin dB	Detector	Comment
1	10400.2600	28.70	16.44	45.14	68.30	-23.16	Peak	
2	15596.0200	31.22	23.30	54.52	74.00	-19.48	Peak	
3 *	15604.2400	20.94	23.30	44.24	54.00	-9.76	AVG	

Orthogonal Axis:	X
Test Mode:	UNII-1/ TX A Mode 5200MHz_ANT2

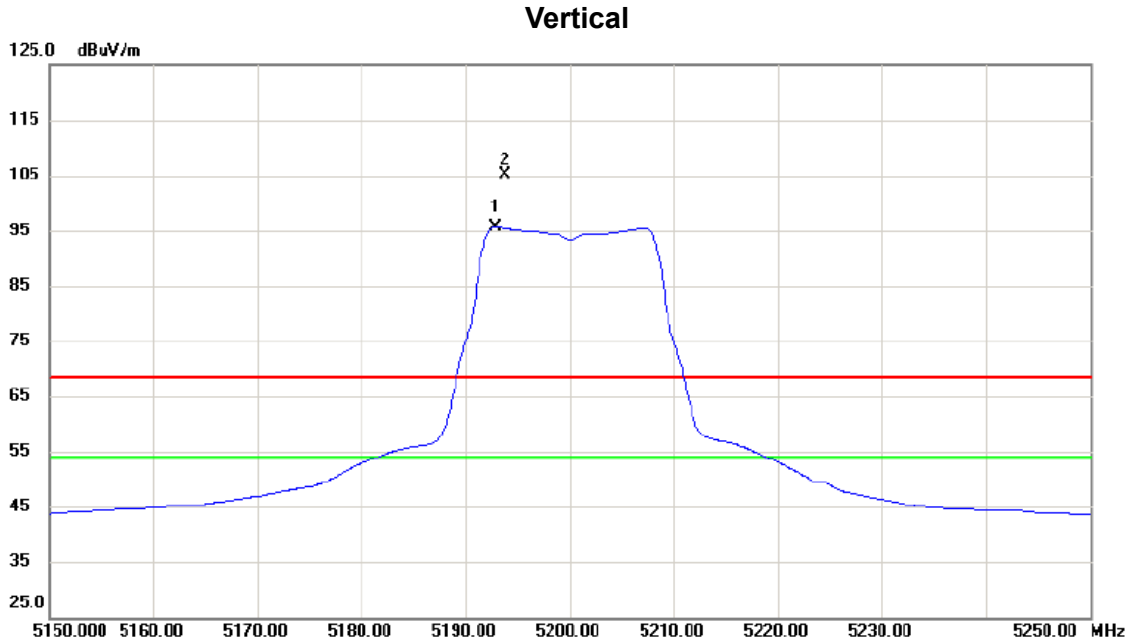

No.	Mk.	Freq. MHz	Reading Level dBuV	Correct Factor dB	Measure- ment dBuV/m	Limit dBuV/m	Margin dB	Detector	Comment
1	*	5192.850	55.09	40.54	95.63	54.00	41.63	AVG	NO LIMIT
2	X	5193.750	64.55	40.55	105.10	68.30	36.80	peak	NO LIMIT

Remark: This test data is from original report BTL-FCCP-4-1602C038.

Orthogonal Axis:	X
Test Mode:	UNII-1/ TX A Mode 5200MHz_ANT2

**Vertical**

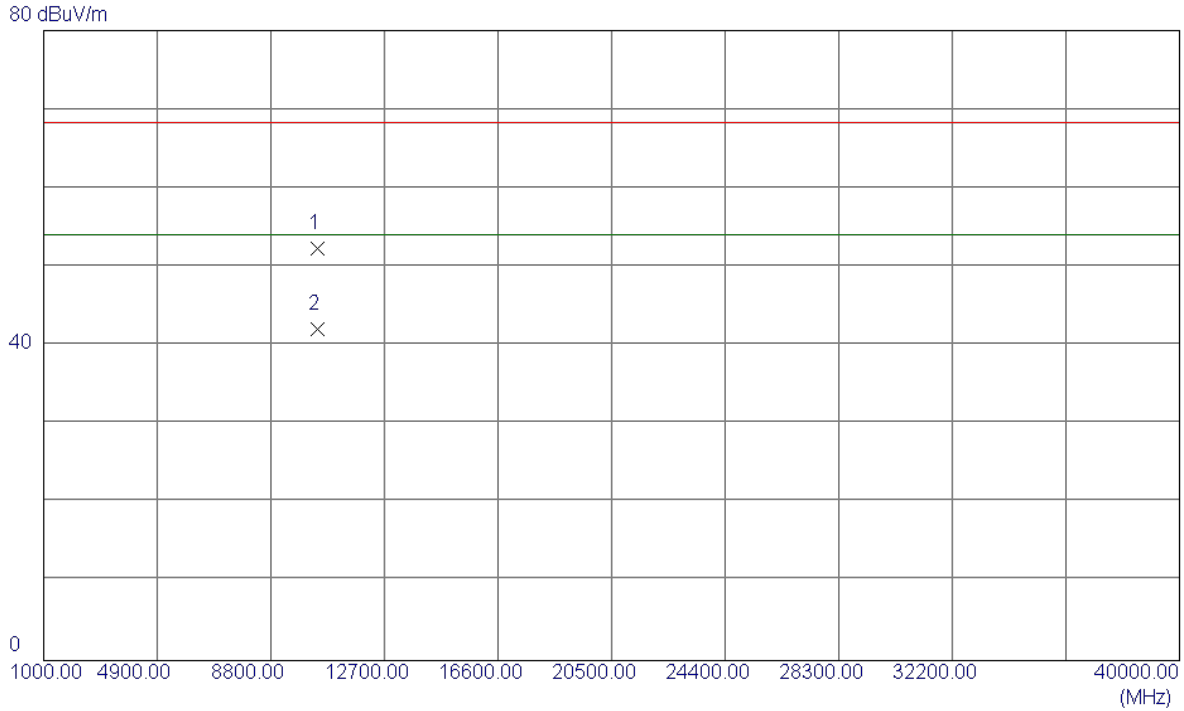

No.	Freq. MHz	Reading Level dBuV/m	Correct Factor dB	Measure ment dBuV/m	Limit dBuV/m	Margin dB	Detector	Comment
1	10400.2600	38.00	14.26	52.26	68.30	-16.04	Peak	
2 *	10400.6500	27.77	14.26	42.03	54.00	-11.97	AVG	

Remark: This test data is from original report BTL-FCCP-4-1602C038.

Orthogonal Axis:	X
Test Mode:	UNII-1/ TX A Mode 5200MHz_ANT2

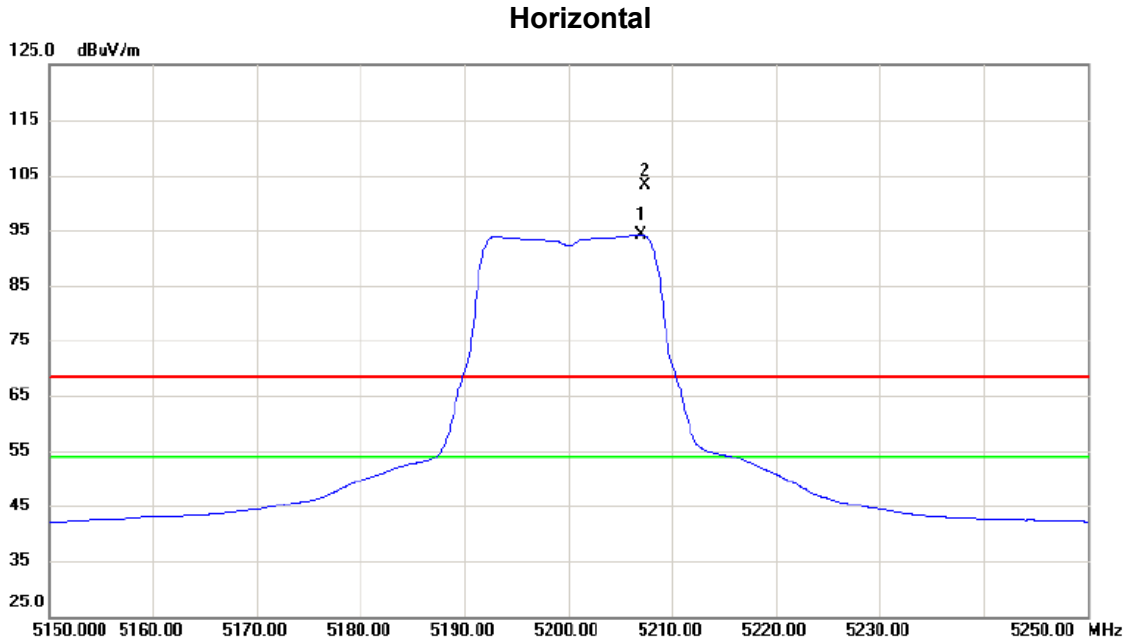

No.	Mk.	Freq. MHz	Reading Level dBuV	Correct Factor dB	Measure- ment dBuV/m	Limit dBuV/m	Margin dB	Detector	Comment
1	*	5206.950	53.54	40.60	94.14	54.00	40.14	AVG	NO LIMIT
2	X	5207.350	62.54	40.60	103.14	68.30	34.84	peak	NO LIMIT

Remark: This test data is from original report BTL-FCCP-4-1602C038.



Orthogonal Axis:	X
Test Mode:	UNII-1/ TX A Mode 5200MHz_ANT2

**Horizontal**

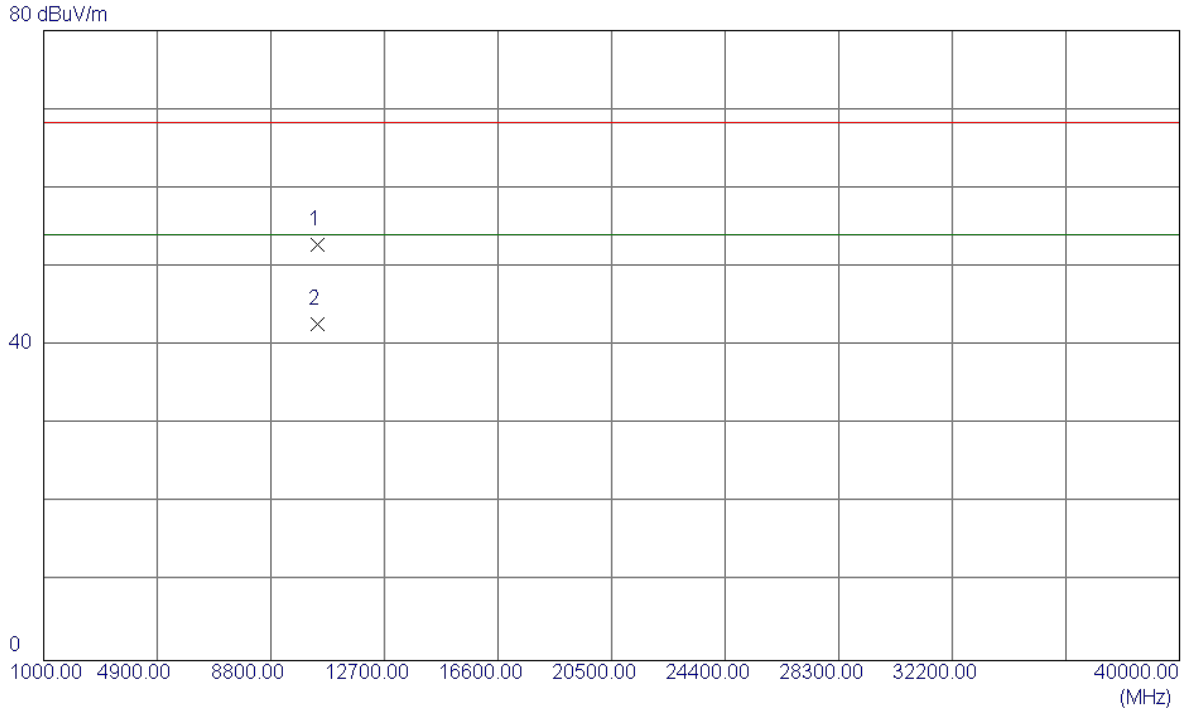

No.	Freq. MHz	Reading Level dBuV/m	Correct Factor dB	Measure ment dBuV/m	Limit dBuV/m	Margin dB	Detector	Comment
1	10400.1200	38.58	14.26	52.84	68.30	-15.46	Peak	
2 *	10400.3720	28.39	14.26	42.65	54.00	-11.35	AVG	

Remark: This test data is from original report BTL-FCCP-4-1602C038.

Orthogonal Axis:	X
Test Mode:	UNII-1/ TX A Mode 5240MHz_ANT1

**Vertical**

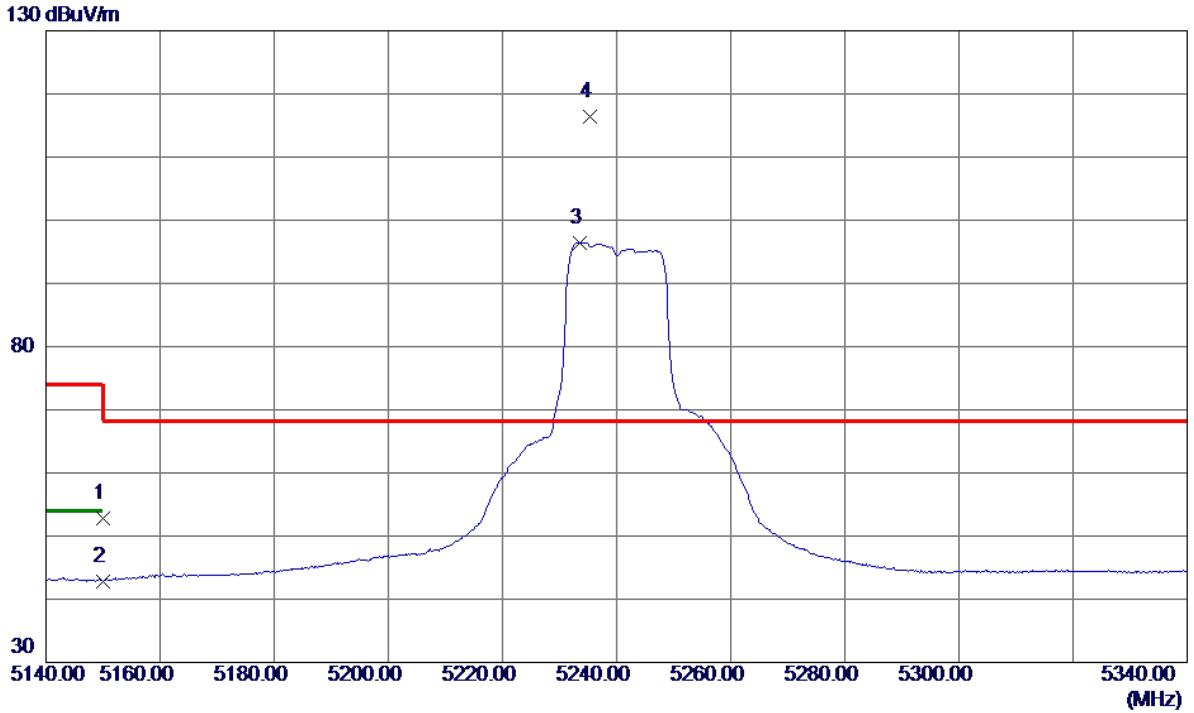

No.	Freq. MHz	Reading Level dBuV/m	Correct Factor dB	Measure ment dBuV/m	Limit dBuV/m	Margin dB	Detector	Comment
1	5150.0000	34.70	18.19	52.89	74.00	-21.11	Peak	
2	5150.0000	24.68	18.19	42.87	54.00	-11.13	AVG	
3	5233.6000	77.77	18.70	96.47	999.00	-902.53	AVG	No Limit
4 *	5235.4000	97.75	18.71	116.46	68.30	48.16	Peak	No Limit

Orthogonal Axis:	X
Test Mode:	UNII-1/ TX A Mode 5240MHz_ANT1

**Vertical**

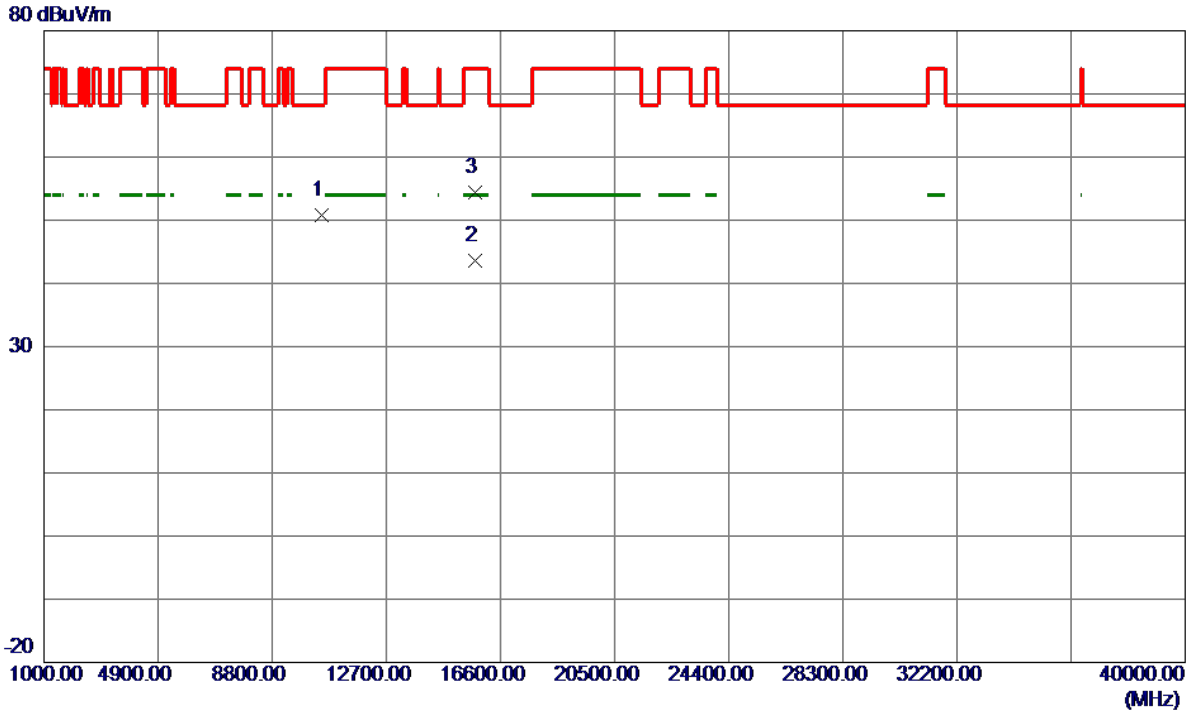

No.	Freq. MHz	Reading Level dBuV/m	Correct Factor dB	Measure ment dBuV/m	Limit dBuV/m	Margin dB	Detector	Comment
1	10477.4200	34.20	16.64	50.84	68.30	-17.46	Peak	
2 *	15720.0200	20.32	23.37	43.69	54.00	-10.31	AVG	
3	15724.1300	31.11	23.37	54.48	74.00	-19.52	Peak	

Orthogonal Axis:	X
Test Mode:	UNII-1/ TX A Mode 5240MHz_ANT1

**Horizontal**

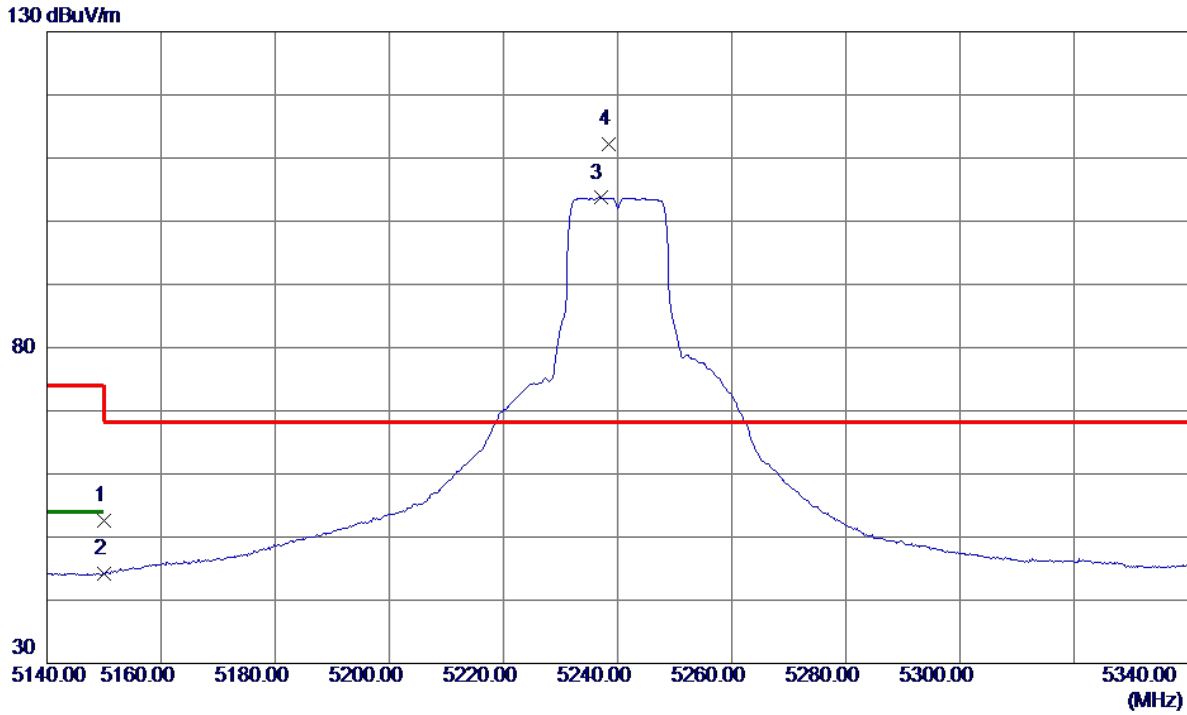

No.	Freq. MHz	Reading Level dBuV/m	Correct Factor dB	Measure ment dBuV/m	Limit dBuV/m	Margin dB	Detector	Comment
1	5150.0000	34.48	18.19	52.67	74.00	-21.33	Peak	
2	5150.0000	26.01	18.19	44.20	54.00	-9.80	AVG	
3	5237.0000	84.98	18.72	103.70	999.00	-895.30	AVG	No Limit
4 *	5238.4000	93.38	18.73	112.11	68.30	43.81	Peak	No Limit

Orthogonal Axis:	X
Test Mode:	UNII-1/ TX A Mode 5240MHz_ANT1

**Horizontal**

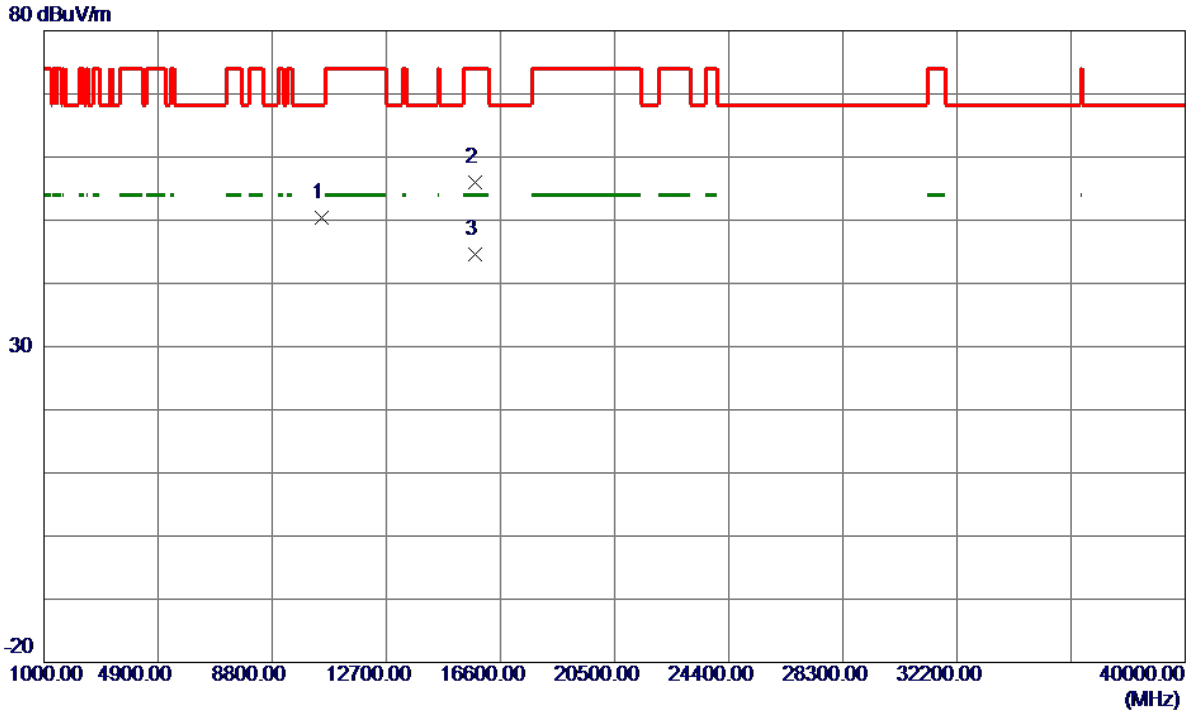

No.	Freq. MHz	Reading Level dBuV/m	Correct Factor dB	Measure ment dBuV/m	Limit dBuV/m	Margin dB	Detector	Comment
1	10480.2000	33.75	16.65	50.40	68.30	-17.90	Peak	
2	15726.4400	32.64	23.37	56.01	74.00	-17.99	Peak	
3 *	15727.8000	21.25	23.37	44.62	54.00	-9.38	AVG	

Orthogonal Axis:	X
Test Mode:	UNII-1/ TX A Mode 5240MHz_ANT2

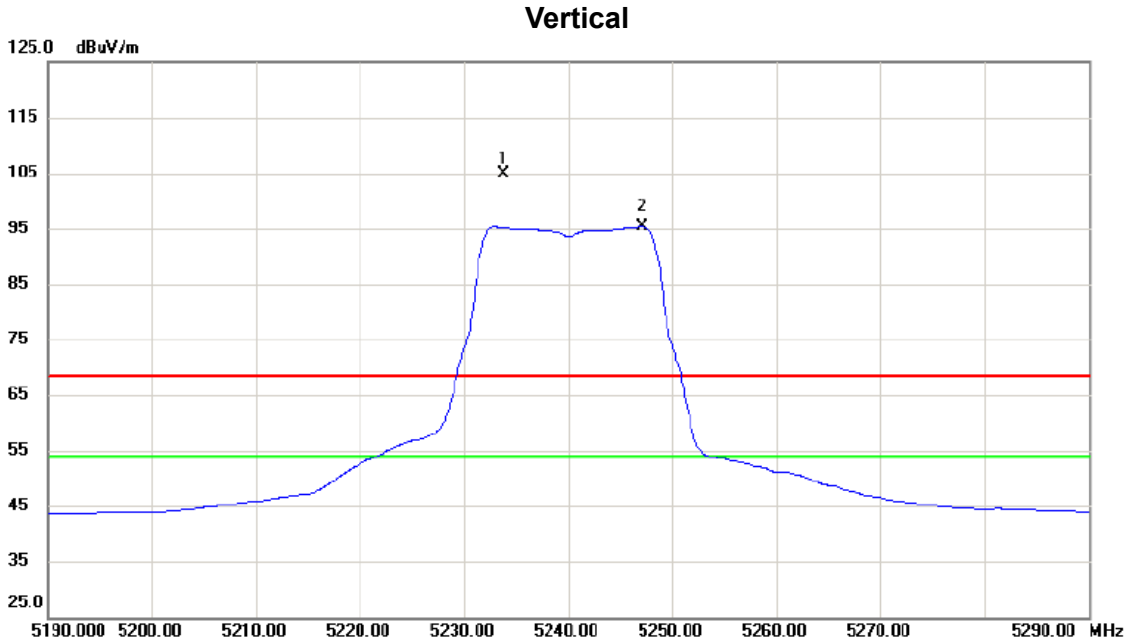

No.	Mk.	Freq. MHz	Reading Level dBuV	Correct Factor dB	Measure- ment dBuV/m	Limit dBuV/m	Margin dB	Detector	Comment
1	X	5233.750	64.21	40.68	104.89	68.30	36.59	peak	NO LIMIT
2	*	5247.100	54.57	40.72	95.29	54.00	41.29	AVG	NO LIMIT

Remark: This test data is from original report BTL-FCCP-4-1602C038.

Orthogonal Axis:	X
Test Mode:	UNII-1/ TX A Mode 5240MHz_ANT2

**Vertical**

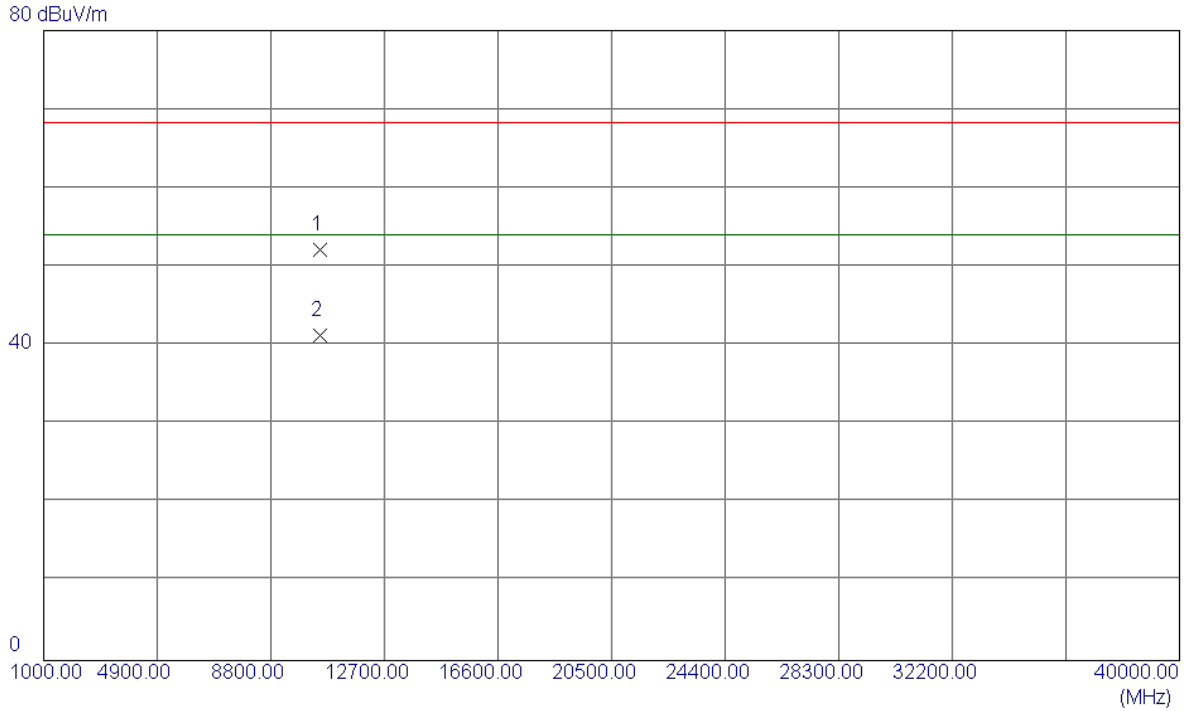

No.	Freq. MHz	Reading Level dBuV/m	Correct Factor dB	Measure ment dBuV/m	Limit dBuV/m	Margin dB	Detector	Comment
1	10479.3560	37.69	14.52	52.21	68.30	-16.09	Peak	
2 *	10481.4600	26.75	14.53	41.28	54.00	-12.72	AVG	

Remark: This test data is from original report BTL-FCCP-4-1602C038.

Orthogonal Axis:	X
Test Mode:	UNII-1/ TX A Mode 5240MHz_ANT2

### Horizontal

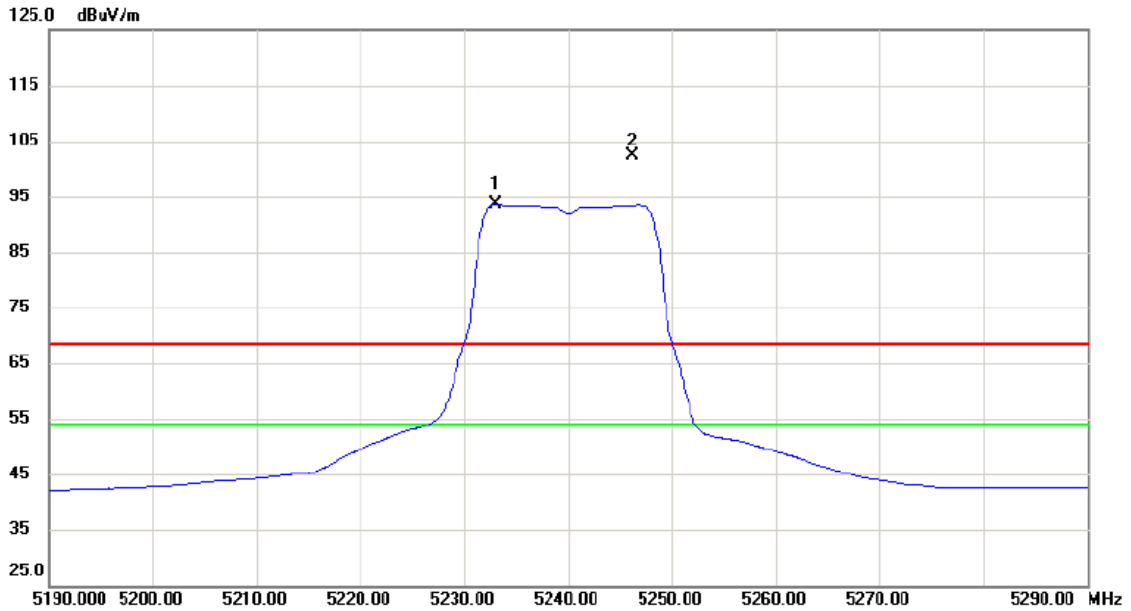

No.	Mk.	Freq. MHz	Reading Level dBuV	Correct Factor dB	Measure- ment dBuV/m	Limit dBuV/m	Margin dB	Detector	Comment
1	*	5232.950	52.92	40.68	93.60	54.00	39.60	AVG	NO LIMIT
2	X	5246.200	61.73	40.72	102.45	68.30	34.15	peak	NO LIMIT

Remark: This test data is from original report BTL-FCCP-4-1602C038.



Orthogonal Axis:	X
Test Mode:	UNII-1/ TX A Mode 5240MHz_ANT2

**Horizontal**

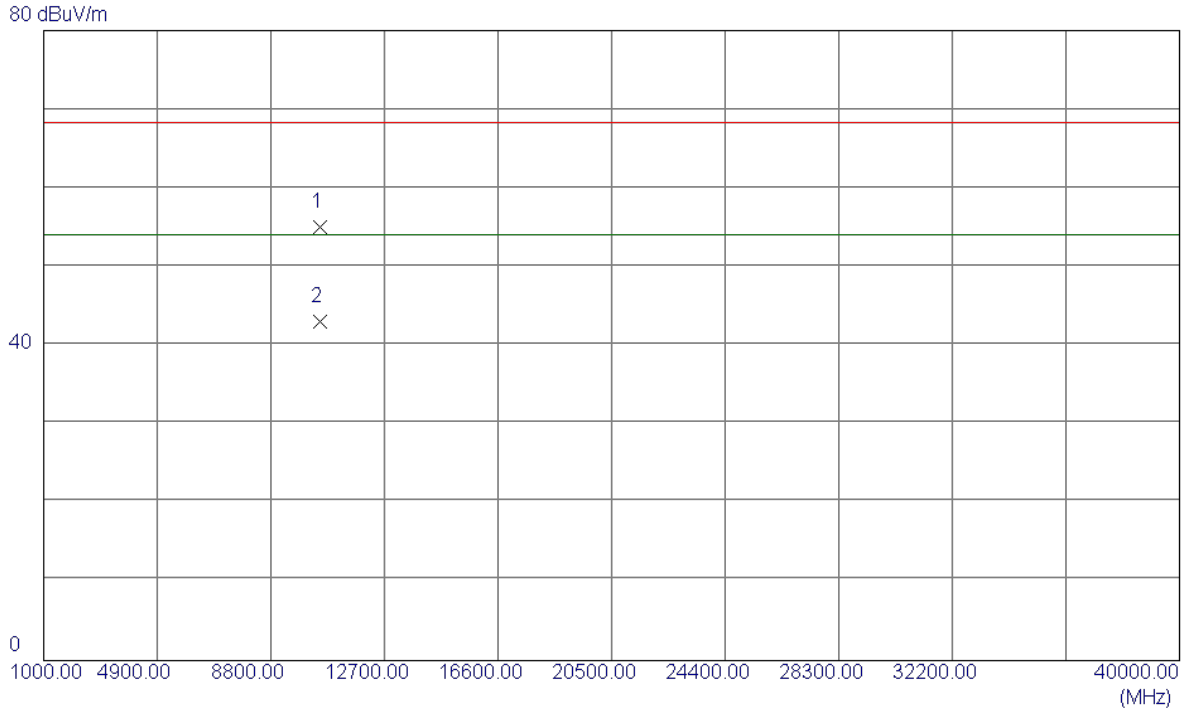

No.	Freq. MHz	Reading Level dBuV/m	Correct Factor dB	Measure ment dBuV/m	Limit dBuV/m	Margin dB	Detector	Comment
1	10480.3600	40.59	14.52	55.11	68.30	-13.19	Peak	
2 *	10481.3259	28.49	14.53	43.02	54.00	-10.98	AVG	

Remark: This test data is from original report BTL-FCCP-4-1602C038.

Orthogonal Axis:	X
Test Mode:	UNII-1/ TX N20 Mode 5180MHz

**Vertical**

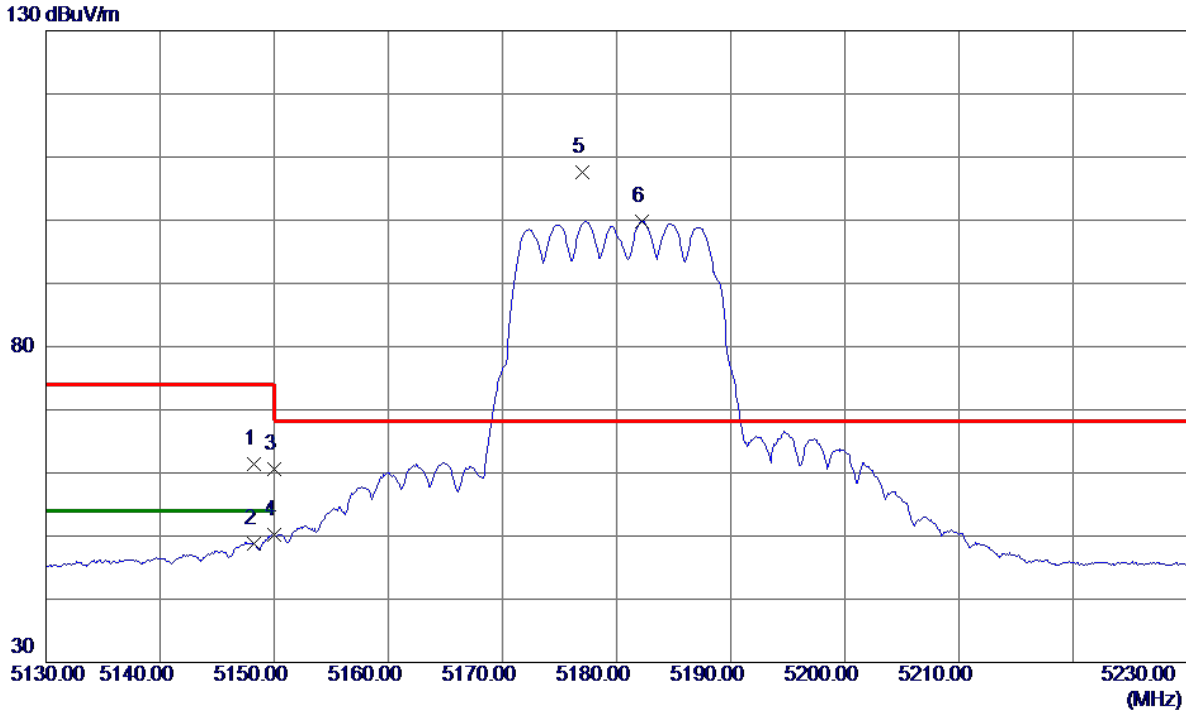

No.	Freq. MHz	Reading Level dBuV/m	Correct Factor dB	Measure ment dBuV/m	Limit dBuV/m	Margin dB	Detector	Comment
1	5148.2000	43.31	18.18	61.49	74.00	-12.51	Peak	
2	5148.2000	30.58	18.18	48.76	54.00	-5.24	AVG	
3	5150.0000	42.46	18.19	60.65	74.00	-13.35	Peak	
4	5150.0000	31.96	18.19	50.15	54.00	-3.85	AVG	
5 *	5177.0000	89.31	18.36	107.67	68.30	39.37	Peak	No Limit
6	5182.2000	81.49	18.39	99.88	999.00	-899.12	AVG	No Limit

Orthogonal Axis:	X
Test Mode:	UNII-1/ TX N20 Mode 5180MHz

**Vertical**

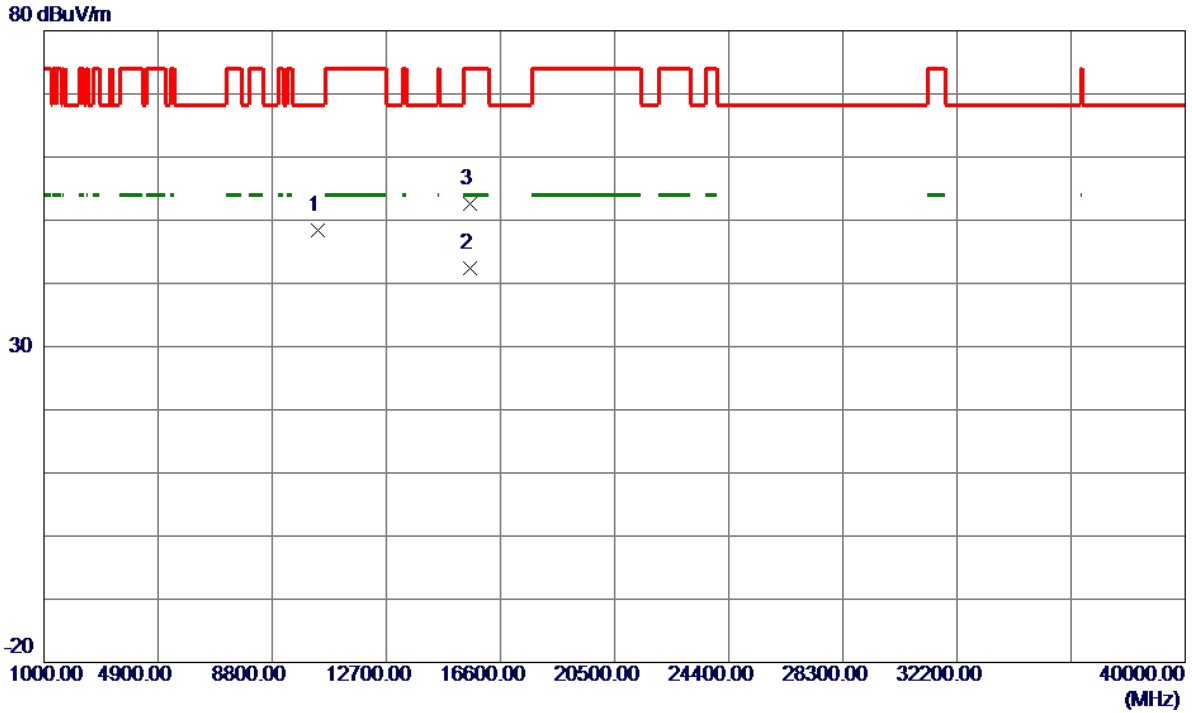

No.	Freq. MHz	Reading Level dBuV/m	Correct Factor dB	Measure ment dBuV/m	Limit dBuV/m	Margin dB	Detector	Comment
1	10357.4100	32.08	16.32	48.40	68.30	-19.90	Peak	
2 *	15540.3200	19.18	23.27	42.45	54.00	-11.55	AVG	
3	15540.4500	29.39	23.27	52.66	74.00	-21.34	Peak	

Orthogonal Axis:	X
Test Mode:	UNII-1/ TX N20 Mode 5180MHz

Horizontal

130 dBuV/m

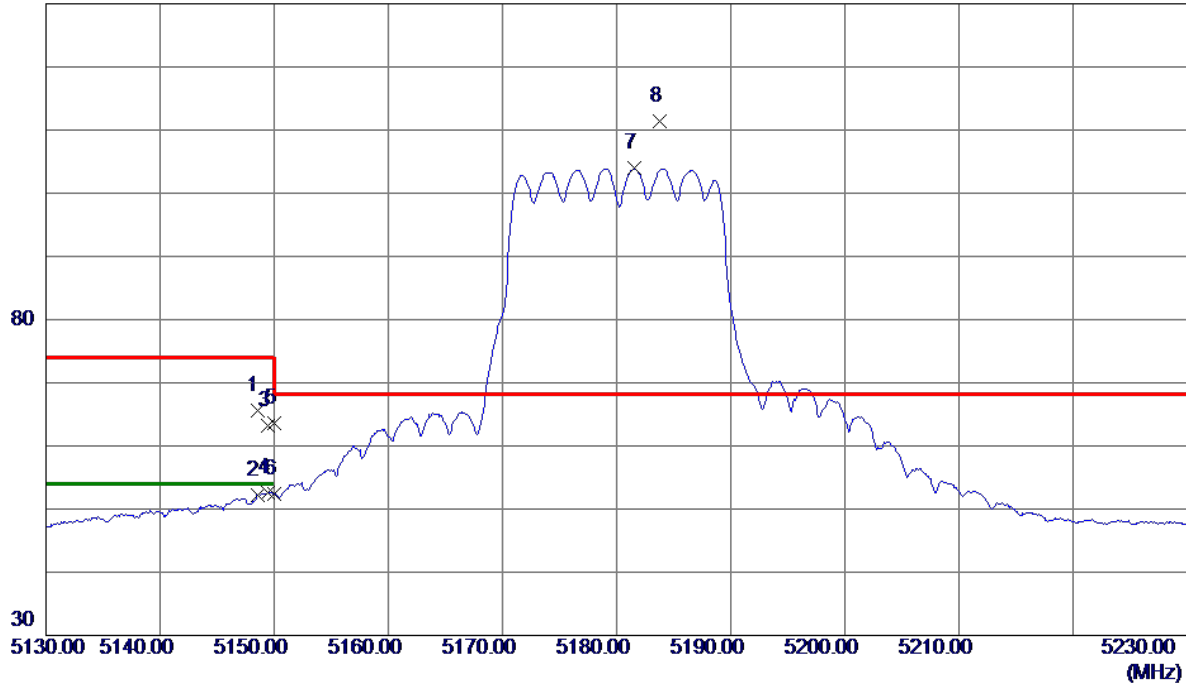

No.	Freq. MHz	Reading Level dBuV/m	Correct Factor dB	Measure ment dBuV/m	Limit dBuV/m	Margin dB	Detector	Comment
1	5148.5000	47.41	18.19	65.60	74.00	-8.40	Peak	
2	5148.5000	34.08	18.19	52.27	54.00	-1.73	AVG	
3	5149.4000	44.92	18.19	63.11	74.00	-10.89	Peak	
4	5149.4000	34.50	18.19	52.69	54.00	-1.31	AVG	
5	5150.0000	45.38	18.19	63.57	74.00	-10.43	Peak	
6	5150.0000	34.15	18.19	52.34	54.00	-1.66	AVG	
7	5181.6000	85.57	18.38	103.95	68.30	35.65	Peak	No Limit
8 *	5183.8000	93.07	18.40	111.47	68.30	43.17	Peak	No Limit

Orthogonal Axis:	X
Test Mode:	UNII-1/ TX N20 Mode 5180MHz

**Horizontal**

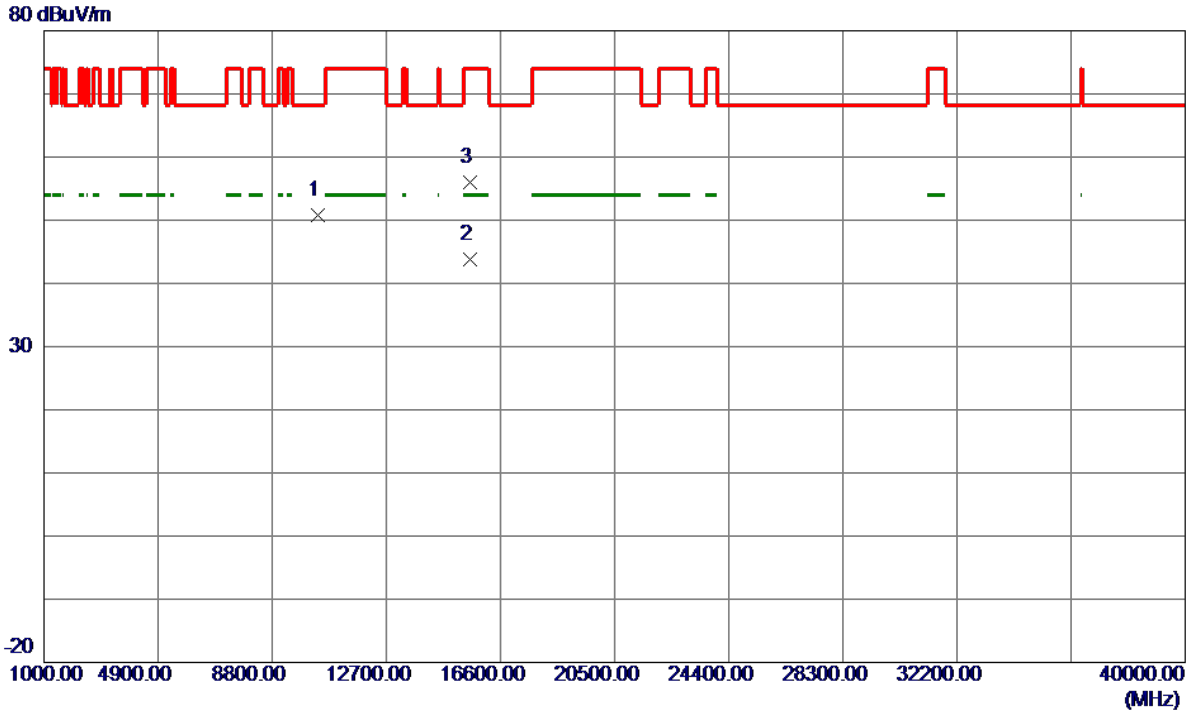

No.	Freq. MHz	Reading Level dBuV/m	Correct Factor dB	Measure ment dBuV/m	Limit dBuV/m	Margin dB	Detector	Comment
1	10355.7200	34.52	16.32	50.84	68.30	-17.46	Peak	
2 *	15540.4400	20.47	23.27	43.74	54.00	-10.26	AVG	
3	15541.3600	32.67	23.27	55.94	74.00	-18.06	Peak	

Orthogonal Axis:	X
Test Mode:	UNII-1/ TX N20 Mode 5200MHz

**Vertical**

130 dBuV/m

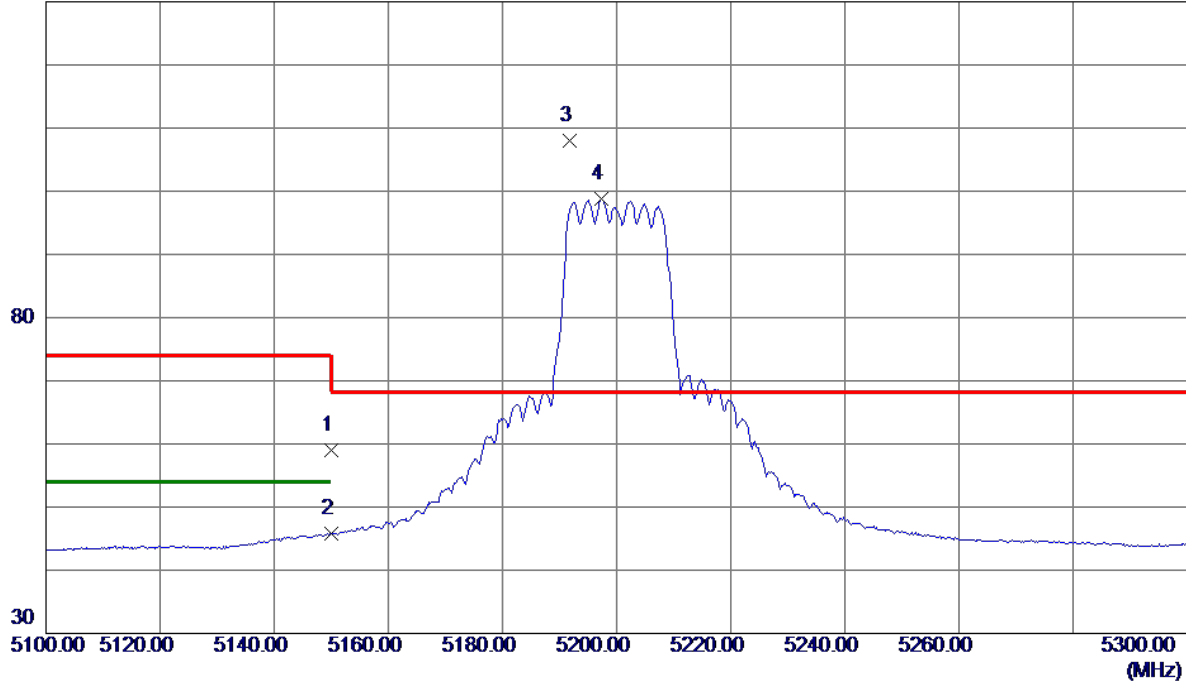

No.	Freq. MHz	Reading Level dBuV/m	Correct Factor dB	Measure ment dBuV/m	Limit dBuV/m	Margin dB	Detector	Comment
1	5150.0000	40.80	18.19	58.99	74.00	-15.01	Peak	
2	5150.0000	27.56	18.19	45.75	54.00	-8.25	AVG	
3 *	5191.8000	89.56	18.45	108.01	68.30	39.71	Peak	No Limit
4	5197.4000	80.23	18.48	98.71	999.00	-900.29	AVG	No Limit

Orthogonal Axis:	X
Test Mode:	UNII-1/ TX N20 Mode 5200MHz

**Vertical**

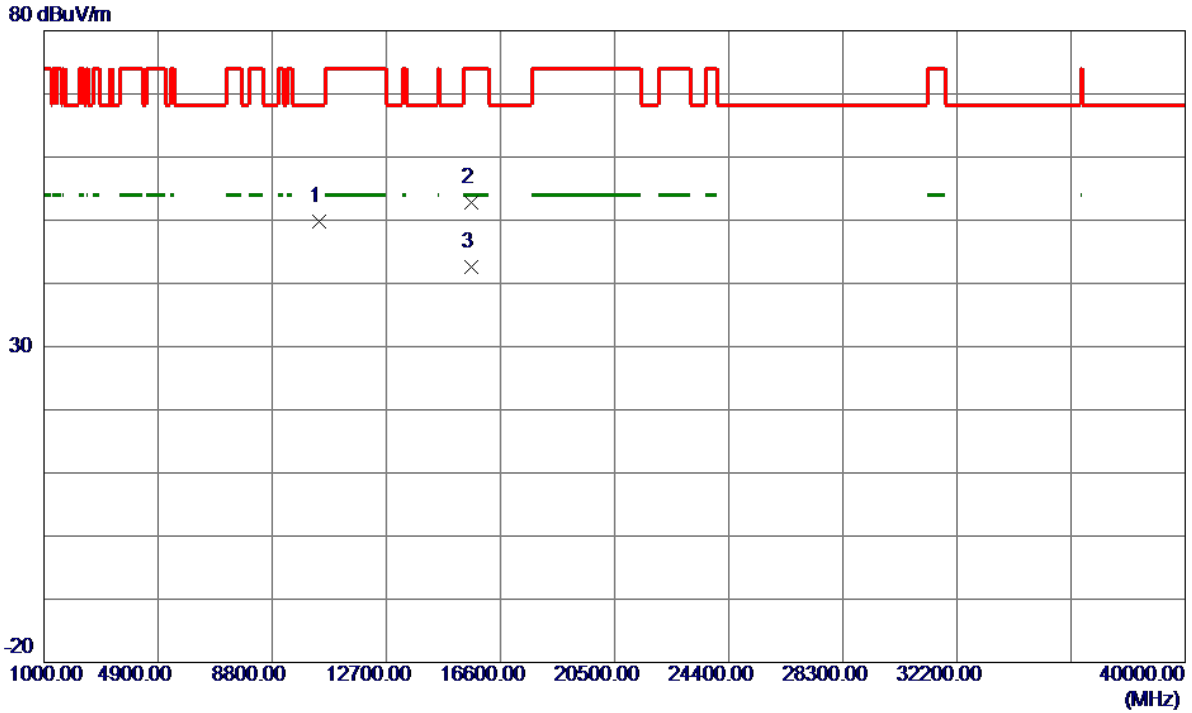

No.	Freq. MHz	Reading Level dBuV/m	Correct Factor dB	Measure ment dBuV/m	Limit dBuV/m	Margin dB	Detector	Comment
1	10396.7200	33.31	16.43	49.74	68.30	-18.56	Peak	
2	15598.1000	29.47	23.30	52.77	74.00	-21.23	Peak	
3 *	15604.8600	19.39	23.30	42.69	54.00	-11.31	AVG	

Orthogonal Axis:	X
Test Mode:	UNII-1/ TX N20 Mode 5200MHz

**Horizontal**

130 dBuV/m

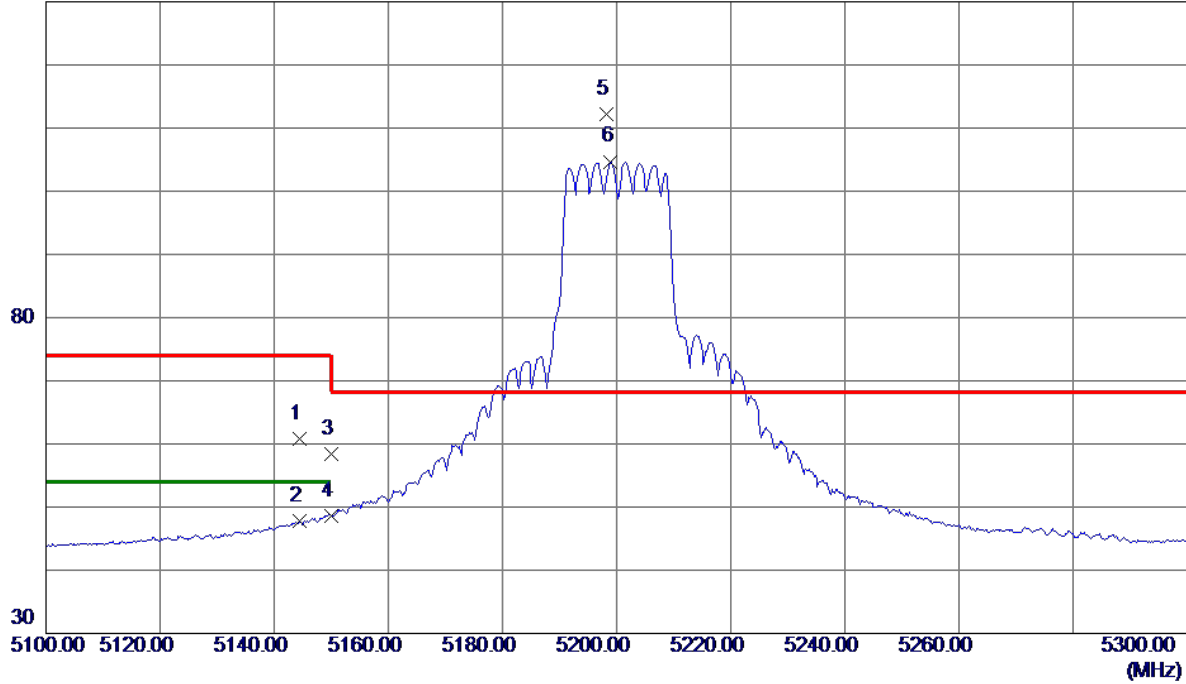

No.	Freq. MHz	Reading Level dBuV/m	Correct Factor dB	Measure ment dBuV/m	Limit dBuV/m	Margin dB	Detector	Comment
1	5144.4000	42.72	18.16	60.88	74.00	-13.12	Peak	
2	5144.4000	29.55	18.16	47.71	54.00	-6.29	AVG	
3	5150.0000	40.13	18.19	58.32	74.00	-15.68	Peak	
4	5150.0000	30.36	18.19	48.55	54.00	-5.45	AVG	
5 *	5198.2000	93.63	18.49	112.12	68.30	43.82	Peak	No Limit
6	5199.0000	86.21	18.49	104.70	999.00	-894.30	AVG	No Limit



Orthogonal Axis:	X
Test Mode:	UNII-1/ TX N20 Mode 5200MHz

**Horizontal**

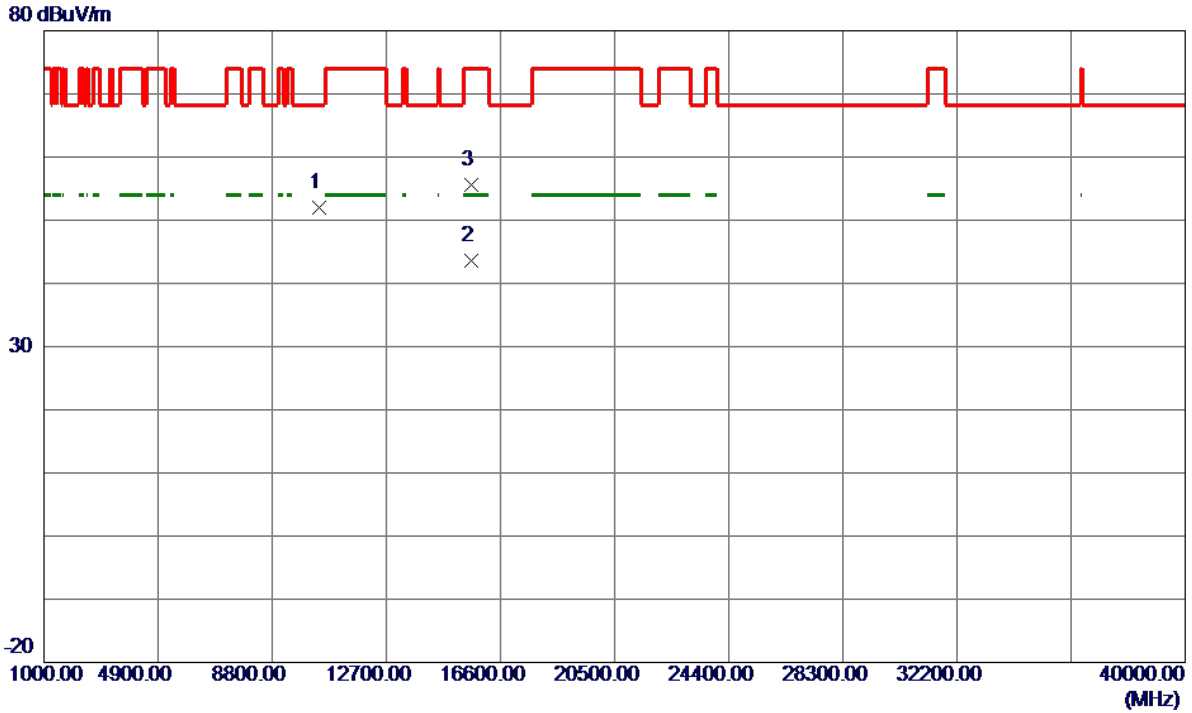

No.	Freq. MHz	Reading Level dBuV/m	Correct Factor dB	Measure ment dBuV/m	Limit dBuV/m	Margin dB	Detector	Comment
1	10399.7600	35.49	16.44	51.93	68.30	-16.37	Peak	
2 *	15600.4700	20.38	23.30	43.68	54.00	-10.32	AVG	
3	15600.5200	32.32	23.30	55.62	74.00	-18.38	Peak	

Orthogonal Axis:	X
Test Mode:	UNII-1/ TX N20 Mode 5240MHz

**Vertical**

130 dBuV/m

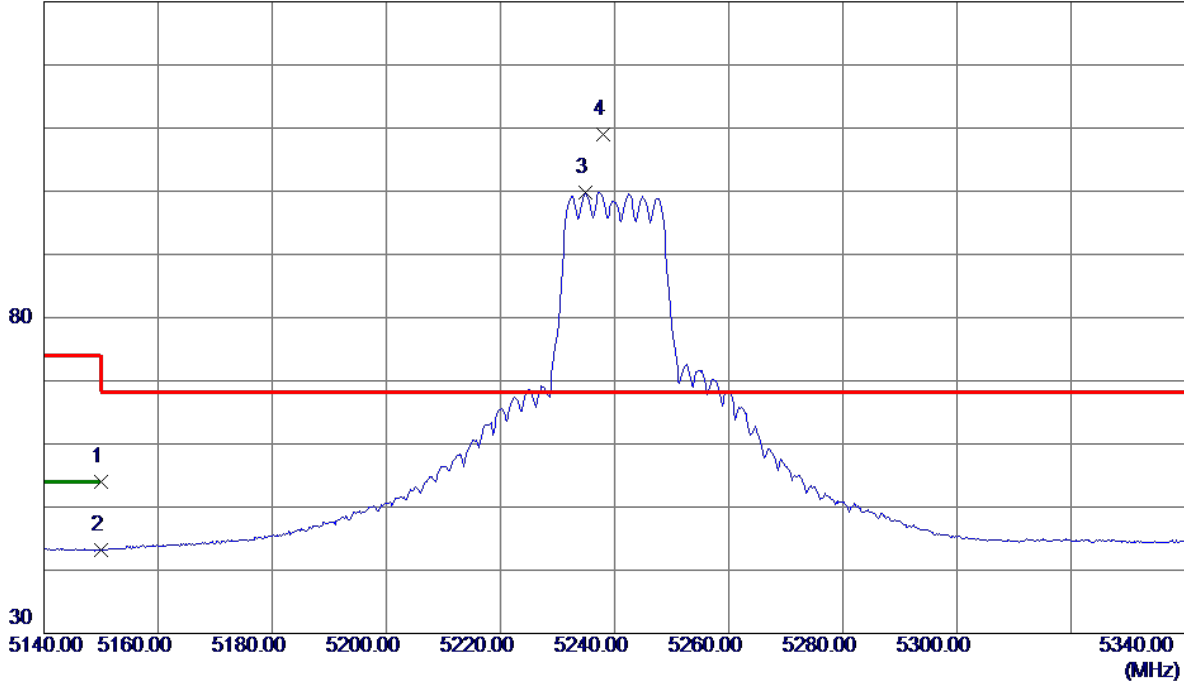

No.	Freq. MHz	Reading Level dBuV/m	Correct Factor dB	Measure ment dBuV/m	Limit dBuV/m	Margin dB	Detector	Comment
1	5150.0000	35.81	18.19	54.00	74.00	-20.00	Peak	
2	5150.0000	24.99	18.19	43.18	54.00	-10.82	AVG	
3	5234.8000	81.06	18.71	99.77	999.00	-899.23	AVG	No Limit
4 *	5238.0000	90.26	18.73	108.99	68.30	40.69	Peak	No Limit

Orthogonal Axis:	X
Test Mode:	UNII-1/ TX N20 Mode 5240MHz

**Vertical**

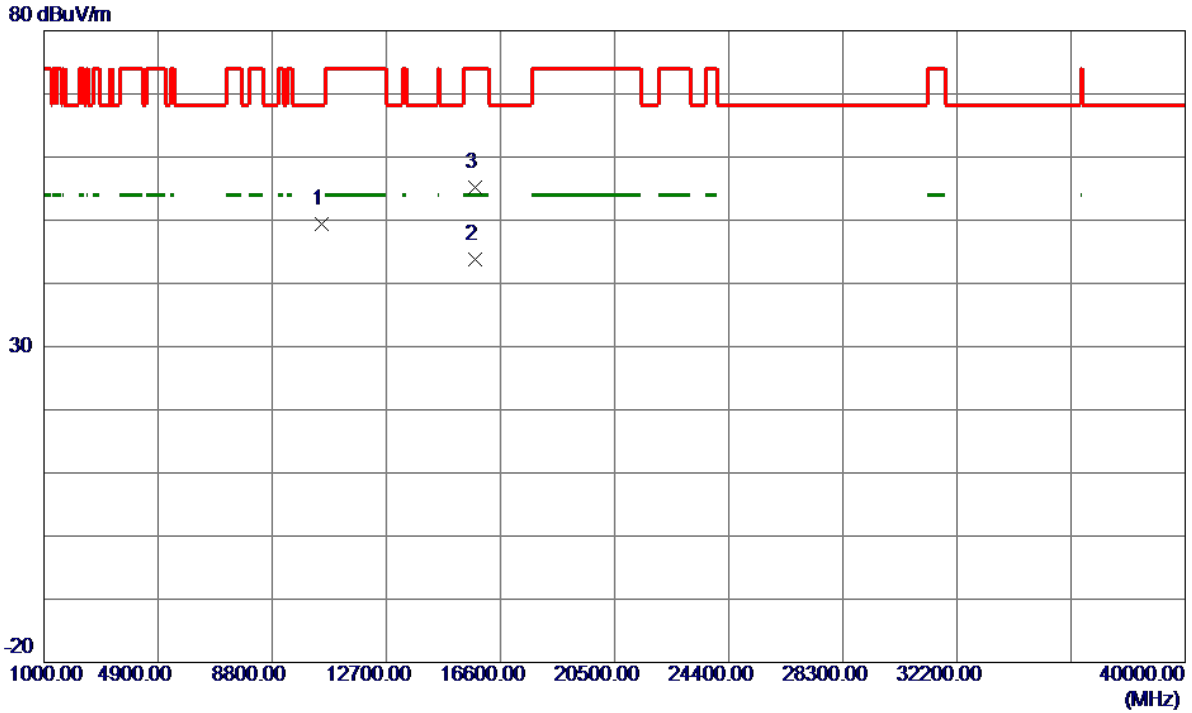

No.	Freq. MHz	Reading Level dBuV/m	Correct Factor dB	Measure ment dBuV/m	Limit dBuV/m	Margin dB	Detector	Comment
1	10475.6800	32.69	16.64	49.33	68.30	-18.97	Peak	
2 *	15718.7200	20.51	23.37	43.88	54.00	-10.12	AVG	
3	15720.4900	31.81	23.37	55.18	74.00	-18.82	Peak	

Orthogonal Axis:	X
Test Mode:	UNII-1/ TX N20 Mode 5240MHz

**Horizontal**

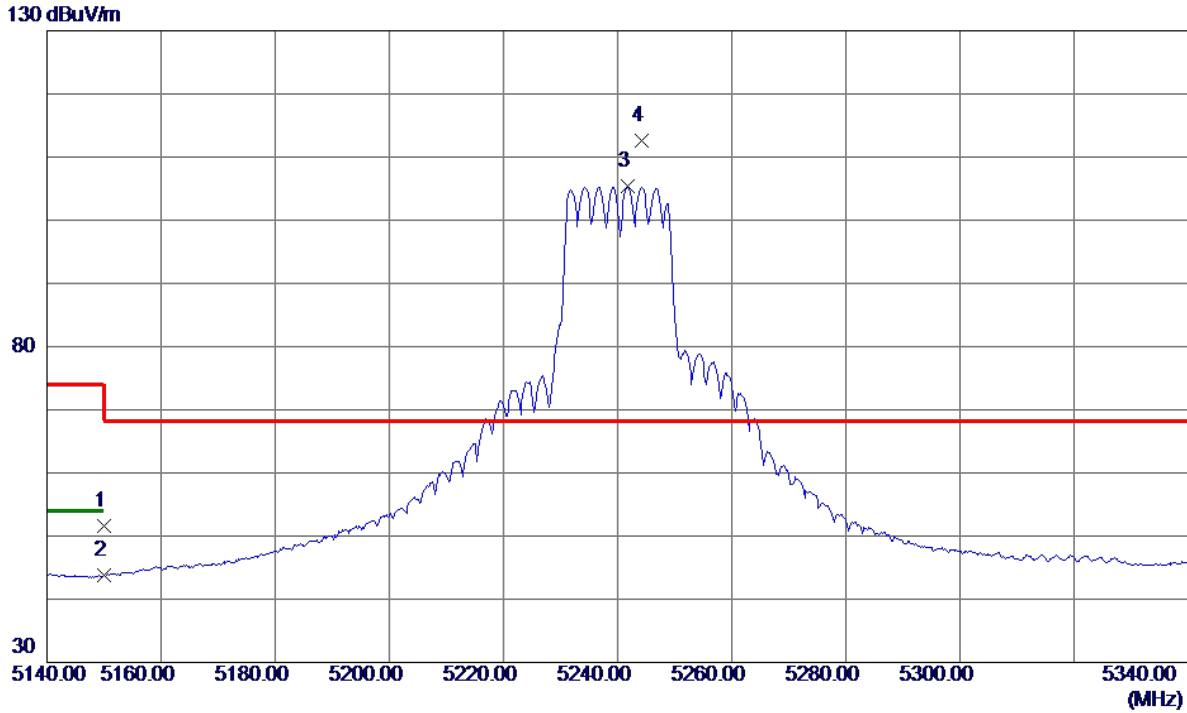

No.	Freq. MHz	Reading Level dBuV/m	Correct Factor dB	Measure ment dBuV/m	Limit dBuV/m	Margin dB	Detector	Comment
1	5150.0000	33.43	18.19	51.62	74.00	-22.38	Peak	
2	5150.0000	25.57	18.19	43.76	54.00	-10.24	AVG	
3	5241.8000	86.62	18.75	105.37	999.00	-893.63	AVG	No Limit
4 *	5244.2000	93.88	18.76	112.64	68.30	44.34	Peak	No Limit

Orthogonal Axis:	X
Test Mode:	UNII-1/ TX N20 Mode 5240MHz

**Horizontal**

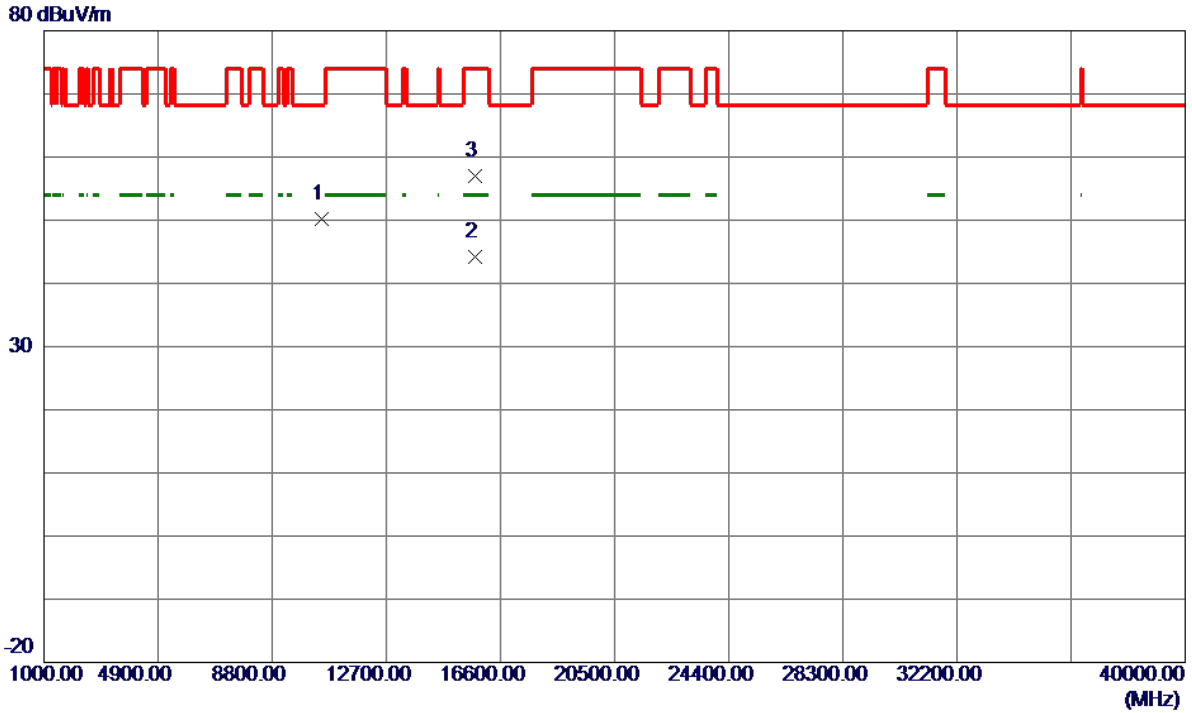

No.	Freq. MHz	Reading Level dBuV/m	Correct Factor dB	Measure ment dBuV/m	Limit dBuV/m	Margin dB	Detector	Comment
1	10477.3000	33.48	16.64	50.12	68.30	-18.18	Peak	
2 *	15719.8300	20.92	23.37	44.29	54.00	-9.71	AVG	
3	15722.8700	33.72	23.37	57.09	74.00	-16.91	Peak	

Orthogonal Axis:	X
Test Mode:	UNII-1/ TX N40 Mode 5190MHz

**Vertical**

130 dBuV/m

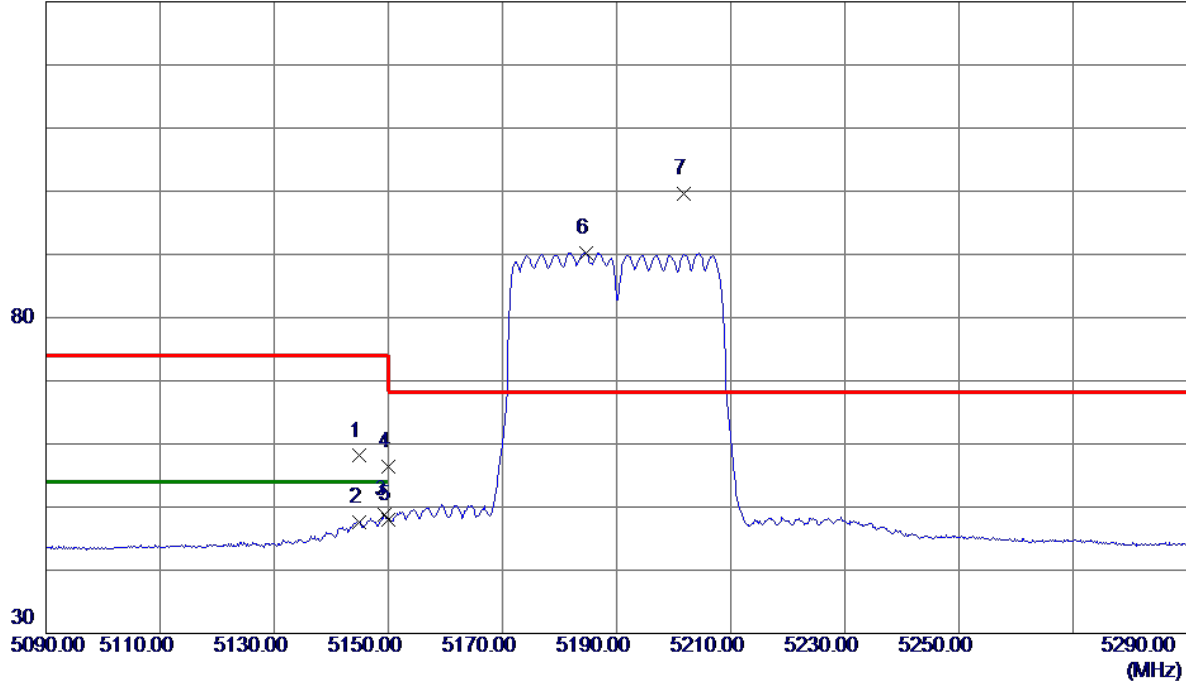

No.	Freq. MHz	Reading Level dBuV/m	Correct Factor dB	Measure ment dBuV/m	Limit dBuV/m	Margin dB	Detector	Comment
1	5144.8000	39.94	18.16	58.10	74.00	-15.90	Peak	
2	5144.8000	29.40	18.16	47.56	54.00	-6.44	AVG	
3	5149.4000	30.63	18.19	48.82	54.00	-5.18	AVG	
4	5150.0000	38.20	18.19	56.39	74.00	-17.61	Peak	
5	5150.0000	29.83	18.19	48.02	54.00	-5.98	AVG	
6	5184.6000	71.86	18.40	90.26	999.00	-908.74	AVG	No Limit
7 *	5201.8000	81.01	18.51	99.52	68.30	31.22	Peak	No Limit

Orthogonal Axis:	X
Test Mode:	UNII-1/ TX N40 Mode 5190MHz

**Vertical**

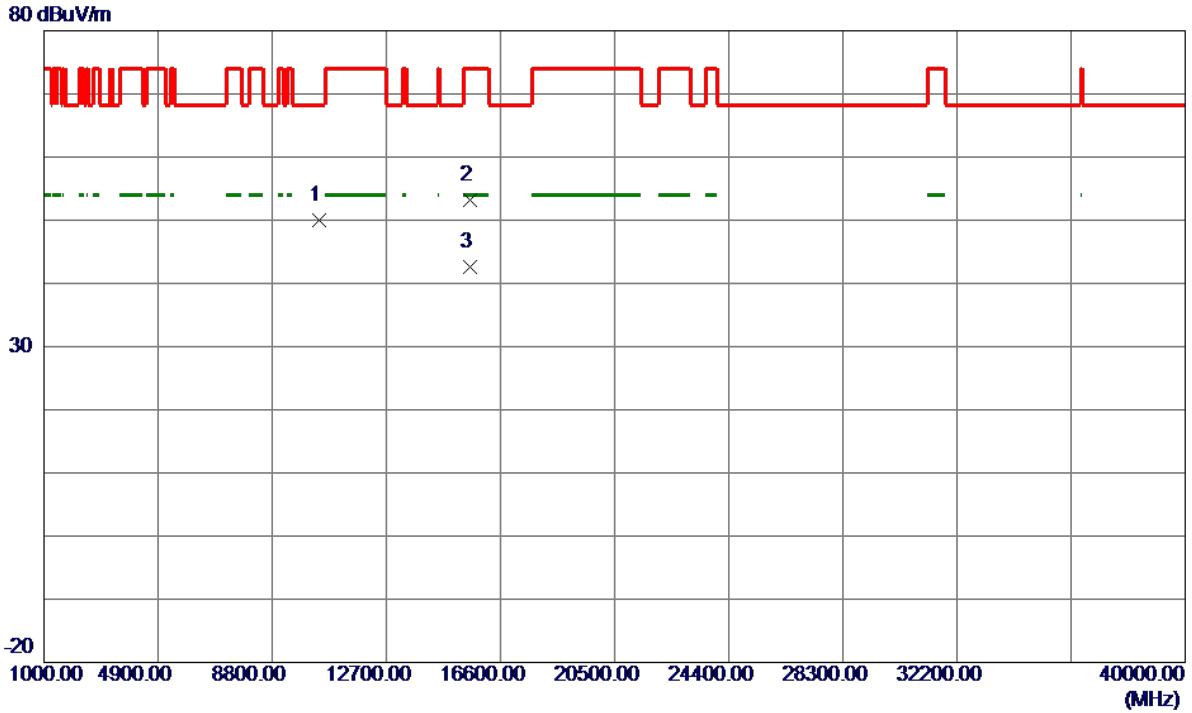

No.	Freq. MHz	Reading Level dBuV/m	Correct Factor dB	Measure ment dBuV/m	Limit dBuV/m	Margin dB	Detector	Comment
1	10384.3099	33.65	16.40	50.05	68.30	-18.25	Peak	
2	15568.4000	29.89	23.28	53.17	74.00	-20.83	Peak	
3 *	15574.9600	19.31	23.29	42.60	54.00	-11.40	AVG	

Orthogonal Axis:	X
Test Mode:	UNII-1/ TX N40 Mode 5190MHz

**Horizontal**

130 dBuV/m

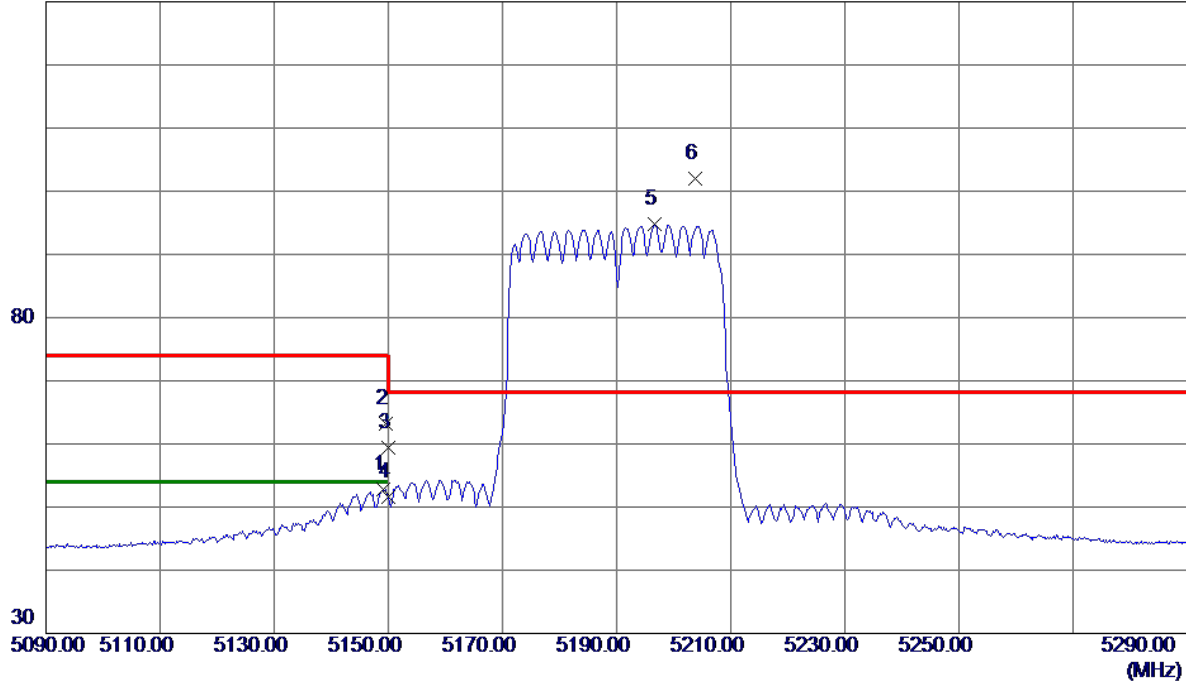

No.	Freq. MHz	Reading Level dBuV/m	Correct Factor dB	Measure ment dBuV/m	Limit dBuV/m	Margin dB	Detector	Comment
1	5149.2000	34.67	18.19	52.86	54.00	-1.14	AVG	
2	5149.6000	44.94	18.19	63.13	74.00	-10.87	Peak	
3	5150.0000	41.27	18.19	59.46	74.00	-14.54	Peak	
4	5150.0000	33.34	18.19	51.53	54.00	-2.47	AVG	
5	5196.6000	76.23	18.48	94.71	999.00	-904.29	AVG	No Limit
6 *	5203.8000	83.53	18.52	102.05	68.30	33.75	Peak	No Limit



Orthogonal Axis:	X
Test Mode:	UNII-1/ TX N40 Mode 5190MHz

**Horizontal**

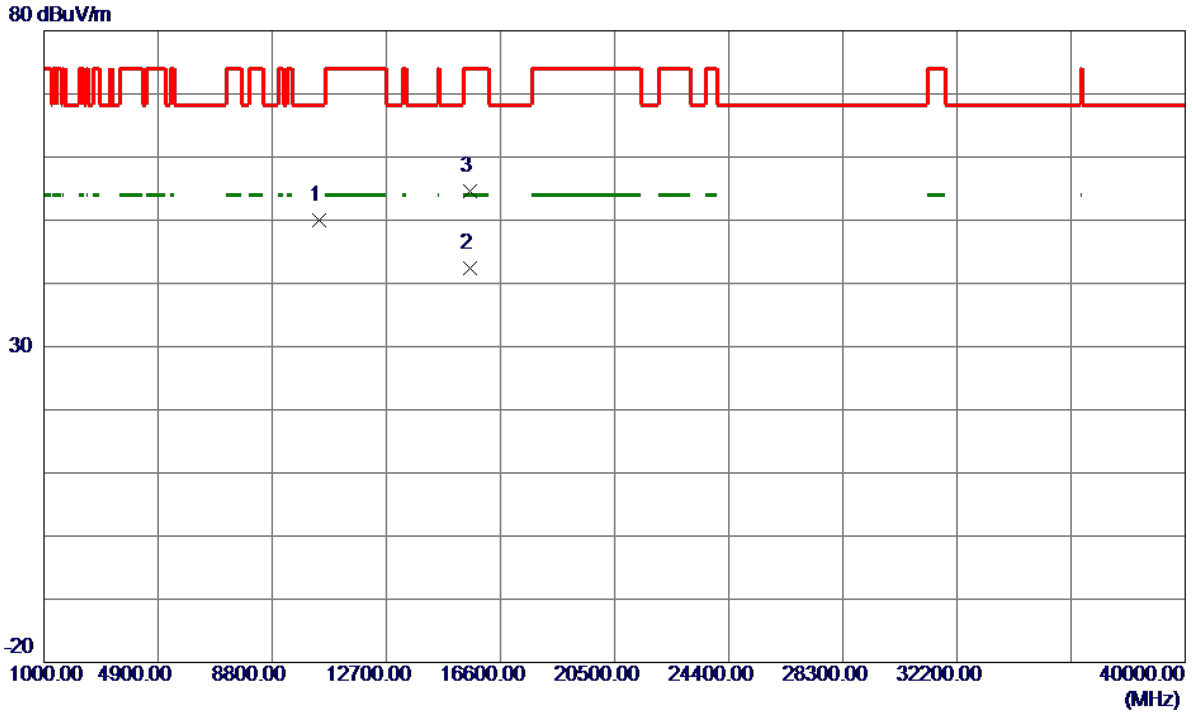

No.	Freq. MHz	Reading Level dBuV/m	Correct Factor dB	Measure ment dBuV/m	Limit dBuV/m	Margin dB	Detector	Comment
1	10383.0700	33.70	16.39	50.09	68.30	-18.21	Peak	
2 *	15569.5900	19.09	23.28	42.37	54.00	-11.63	AVG	
3	15571.9200	31.37	23.28	54.65	74.00	-19.35	Peak	

Orthogonal Axis:	X
Test Mode:	UNII-1/ TX N40 Mode 5230MHz

**Vertical**

130 dBuV/m

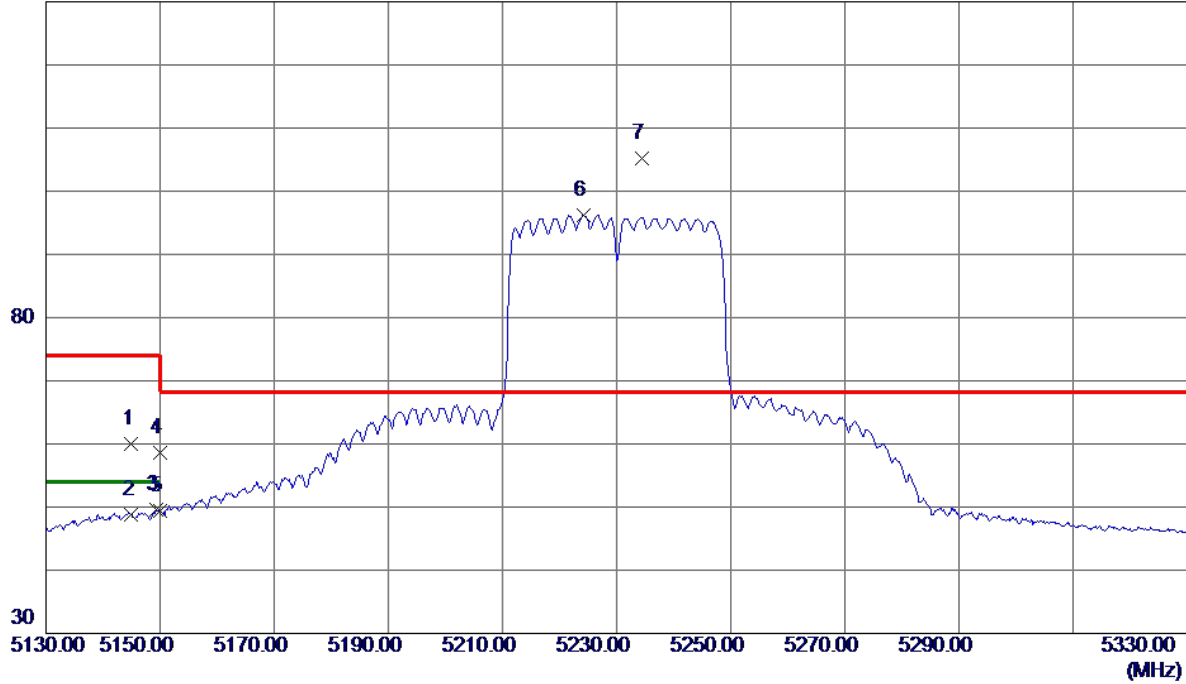

No.	Freq. MHz	Reading Level dBuV/m	Correct Factor dB	Measure ment dBuV/m	Limit dBuV/m	Margin dB	Detector	Comment
1	5145.0000	41.82	18.16	59.98	74.00	-14.02	Peak	
2	5145.0000	30.72	18.16	48.88	54.00	-5.12	AVG	
3	5149.4000	31.46	18.19	49.65	54.00	-4.35	AVG	
4	5150.0000	40.41	18.19	58.60	74.00	-15.40	Peak	
5	5150.0000	31.13	18.19	49.32	54.00	-4.68	AVG	
6	5224.2000	77.59	18.64	96.23	999.00	-902.77	AVG	No Limit
7 *	5234.4000	86.54	18.70	105.24	68.30	36.94	Peak	No Limit

Orthogonal Axis:	X
Test Mode:	UNII-1/ TX N40 Mode 5230MHz

**Vertical**

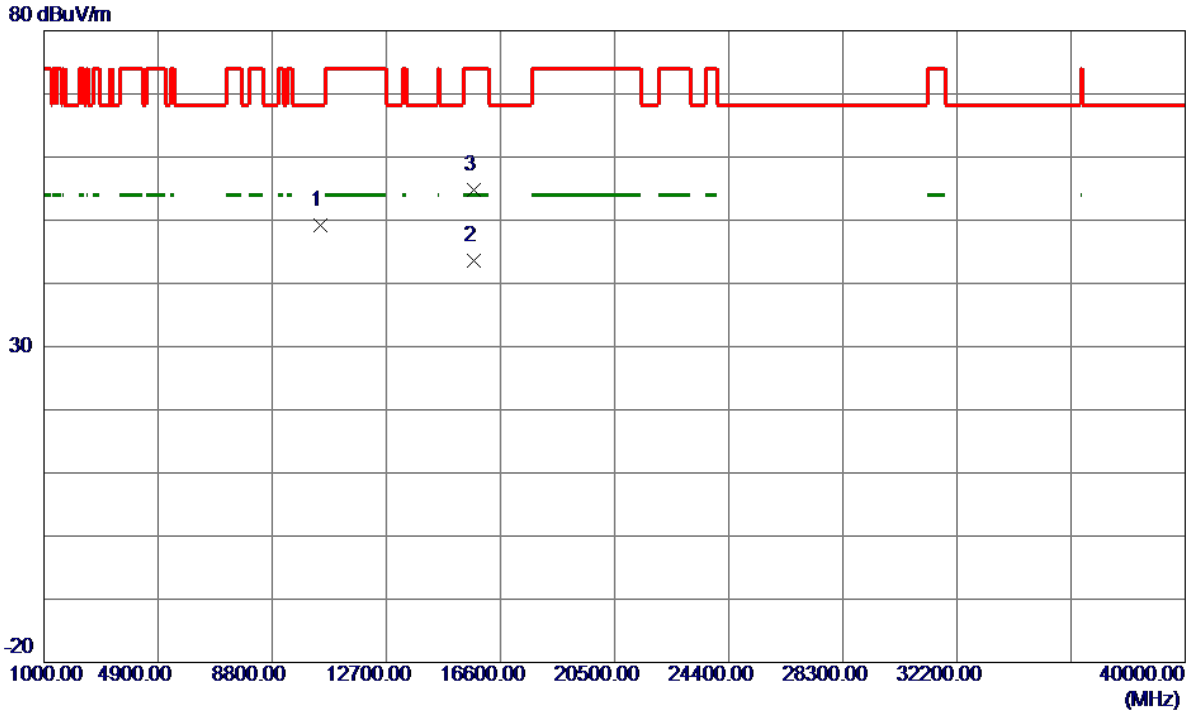

No.	Freq. MHz	Reading Level dBuV/m	Correct Factor dB	Measure ment dBuV/m	Limit dBuV/m	Margin dB	Detector	Comment
1	10462.9600	32.64	16.61	49.25	68.30	-19.05	Peak	
2 *	15686.7400	20.25	23.35	43.60	54.00	-10.40	AVG	
3	15692.5500	31.50	23.35	54.85	74.00	-19.15	Peak	

Orthogonal Axis:	X
Test Mode:	UNII-1/ TX N40 Mode 5230MHz

### Horizontal

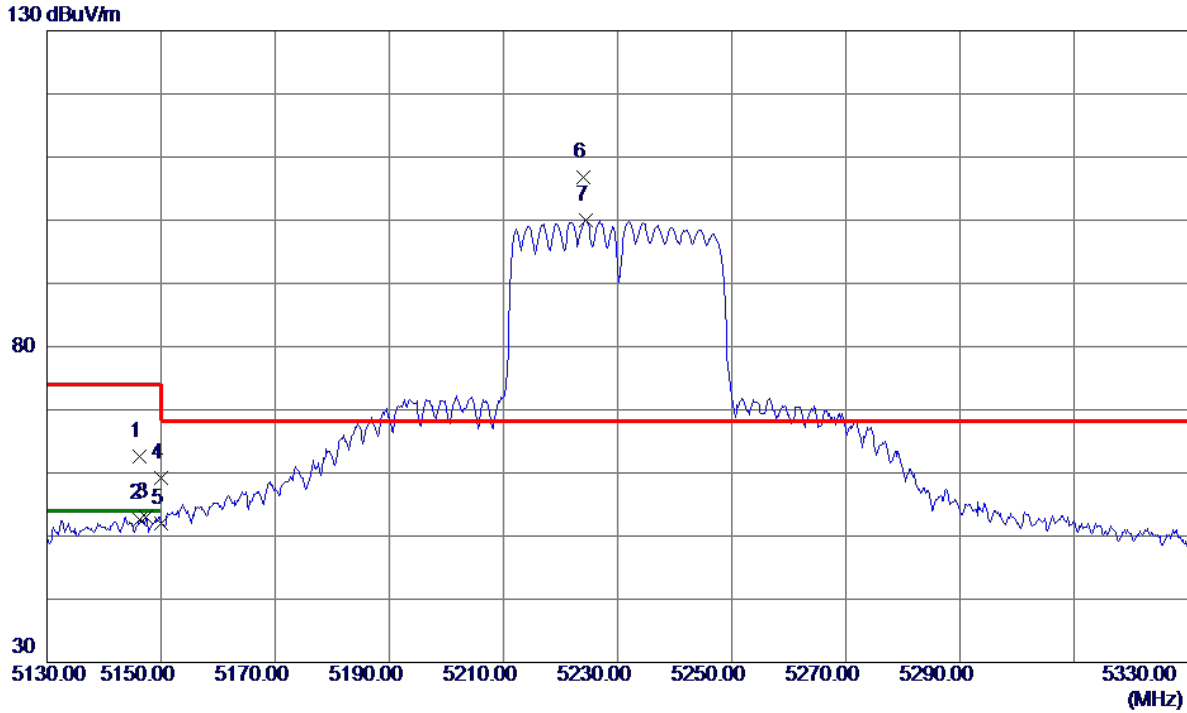

No.	Freq. MHz	Reading Level dBuV/m	Correct Factor dB	Measure ment dBuV/m	Limit dBuV/m	Margin dB	Detector	Comment
1	5146.2000	44.42	18.17	62.59	74.00	-11.41	Peak	
2	5146.2000	34.53	18.17	52.70	54.00	-1.30	AVG	
3	5147.4000	34.82	18.18	53.00	54.00	-1.00	AVG	
4	5150.0000	41.03	18.19	59.22	74.00	-14.78	Peak	
5	5150.0000	33.89	18.19	52.08	54.00	-1.92	AVG	
6 *	5224.0000	88.24	18.64	106.88	68.30	38.58	Peak	No Limit
7	5224.4000	81.34	18.64	99.98	999.00	-899.02	AVG	No Limit

Orthogonal Axis:	X
Test Mode:	UNII-1/ TX N40 Mode 5230MHz

**Horizontal**

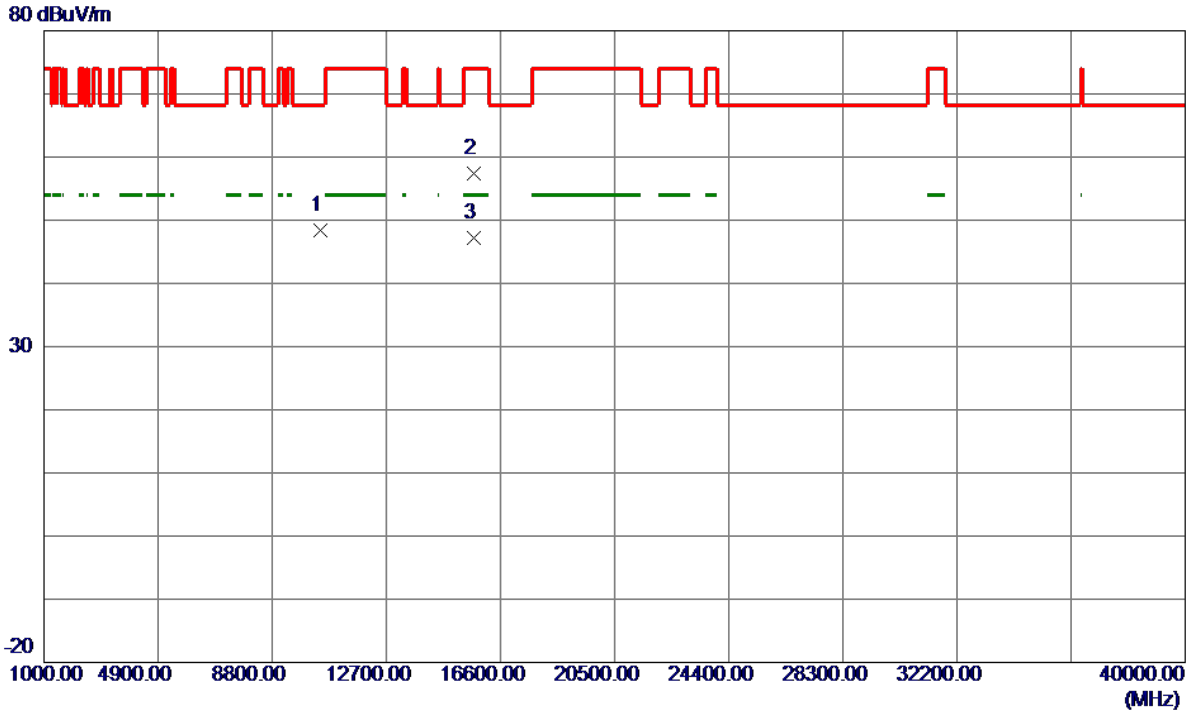

No.	Freq. MHz	Reading Level dBuV/m	Correct Factor dB	Measure ment dBuV/m	Limit dBuV/m	Margin dB	Detector	Comment
1	10459.8500	31.73	16.60	48.33	68.30	-19.97	Peak	
2	15692.5000	34.05	23.35	57.40	74.00	-16.60	Peak	
3 *	15692.7000	23.88	23.35	47.23	54.00	-6.77	AVG	

Orthogonal Axis :	X
Test Mode :	UNII-2A/ TX A Mode 5260MHz_ANT1

**Vertical**

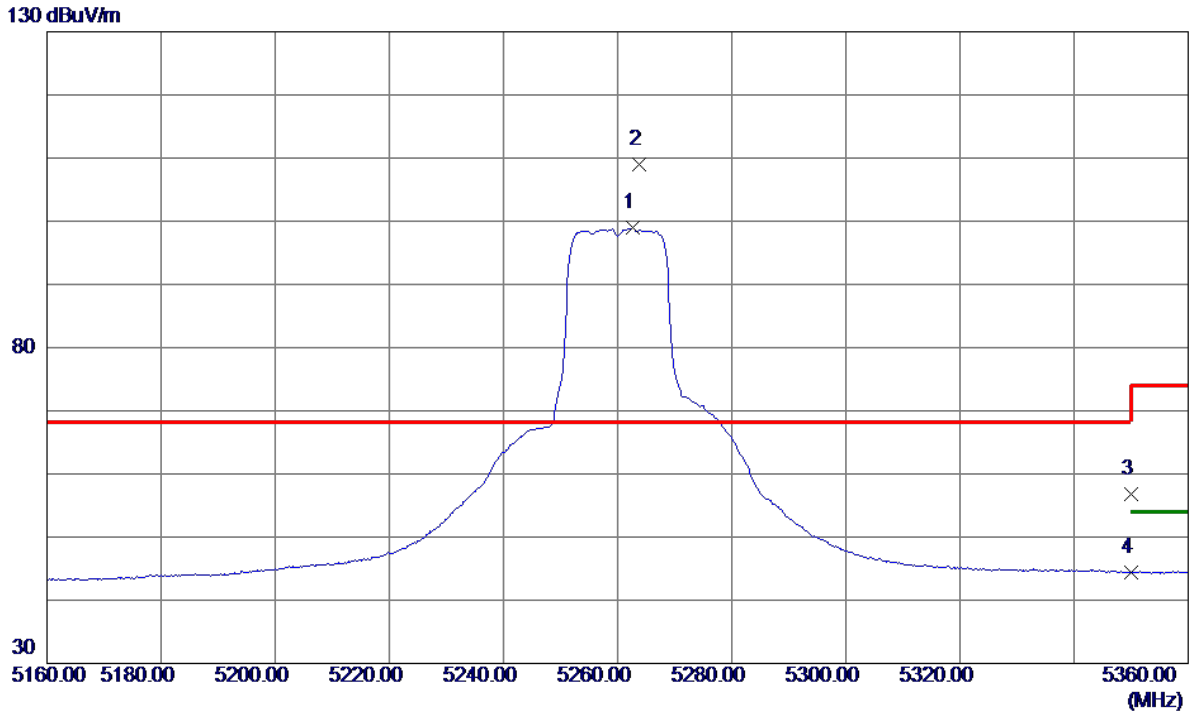

No.	Freq. MHz	Reading Level dBuV/m	Correct Factor dB	Measure ment dBuV/m	Limit dBuV/m	Margin dB	Detector	Comment
1	5262.6000	80.04	18.87	98.91	999.00	-900.09	AVG	No Limit
2 *	5263.8000	90.03	18.88	108.91	68.30	40.61	Peak	No Limit
3	5350.0000	37.35	19.40	56.75	74.00	-17.25	Peak	
4	5350.0000	25.03	19.40	44.43	999.00	-954.57	AVG	

Orthogonal Axis :	X
Test Mode :	UNII-2A/ TX A Mode 5260MHz_ANT1

**Vertical**

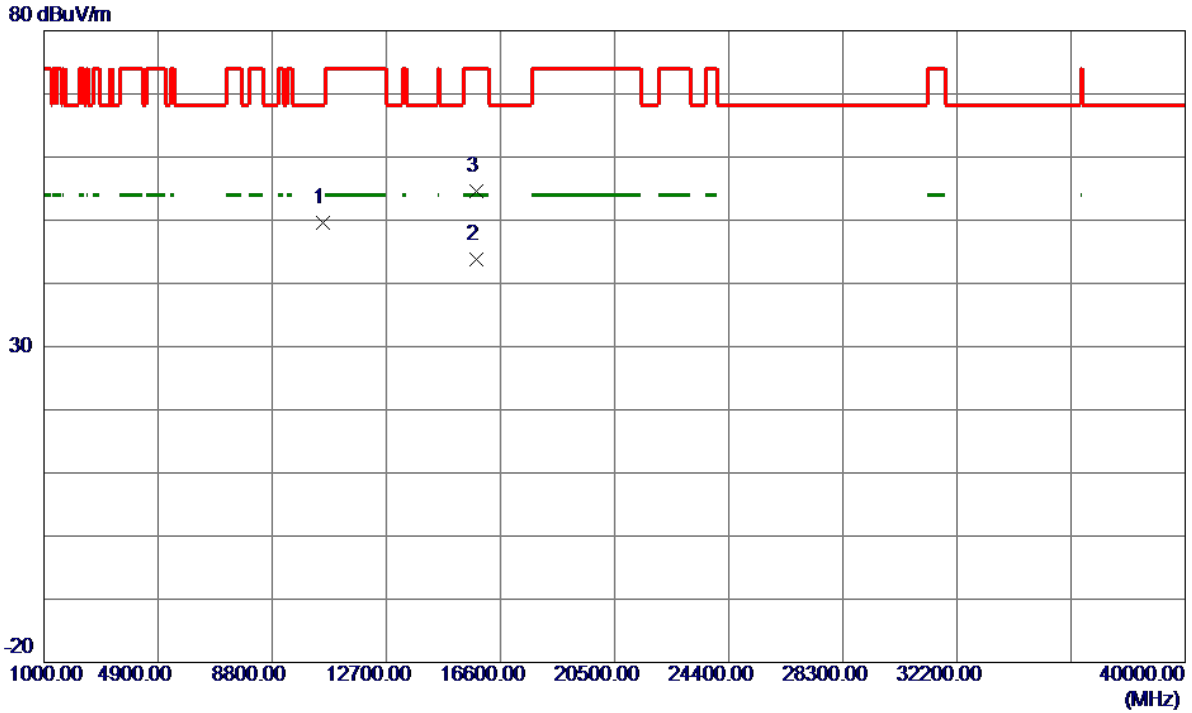

No.	Freq. MHz	Reading Level dBuV/m	Correct Factor dB	Measure ment dBuV/m	Limit dBuV/m	Margin dB	Detector	Comment
1	10517.0500	32.93	16.68	49.61	68.30	-18.69	Peak	
2 *	15777.7200	20.40	23.40	43.80	54.00	-10.20	AVG	
3	15781.7300	31.13	23.40	54.53	74.00	-19.47	Peak	

Orthogonal Axis :	X
Test Mode :	UNII-2A/ TX A Mode 5260MHz_ANT1

**Horizontal**

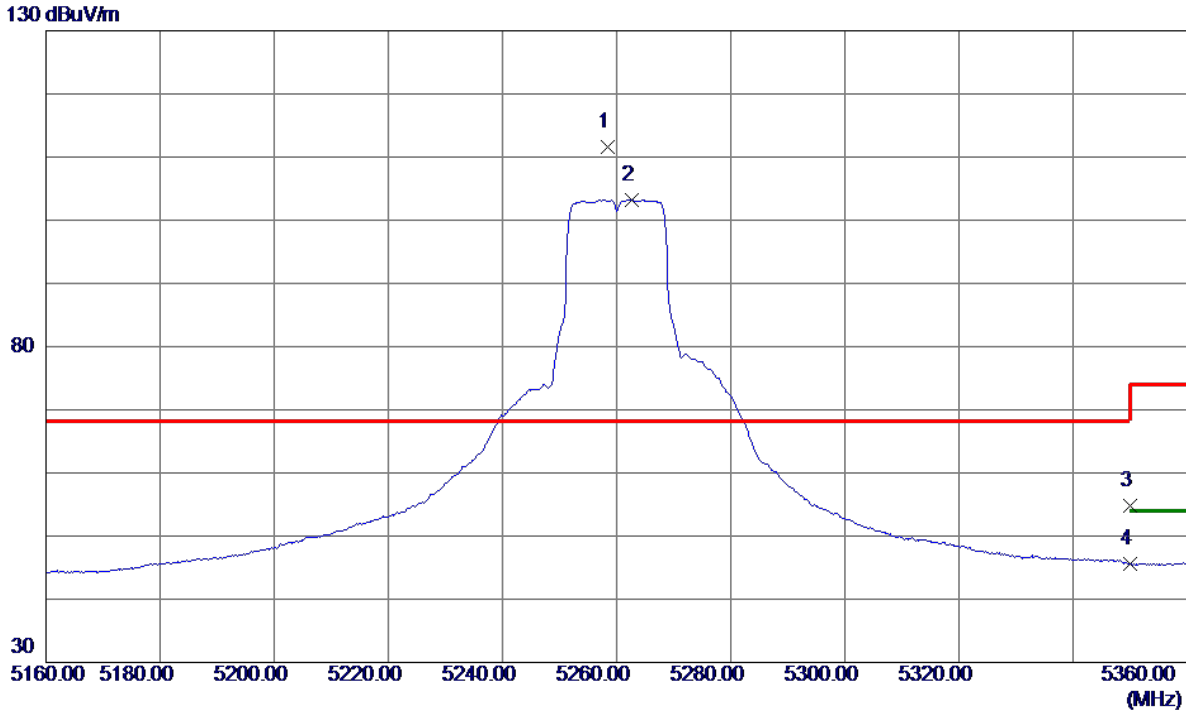

No.	Freq. MHz	Reading Level dBuV/m	Correct Factor dB	Measure ment dBuV/m	Limit dBuV/m	Margin dB	Detector	Comment
1 *	5258.4000	92.68	18.85	111.53	68.30	43.23	Peak	No Limit
2	5262.6000	84.33	18.87	103.20	999.00	-895.80	AVG	No Limit
3	5350.0000	35.39	19.40	54.79	74.00	-19.21	Peak	
4	5350.0000	26.24	19.40	45.64	999.00	-953.36	AVG	



Orthogonal Axis :	X
Test Mode :	UNII-2A/ TX A Mode 5260MHz_ANT1

**Horizontal**

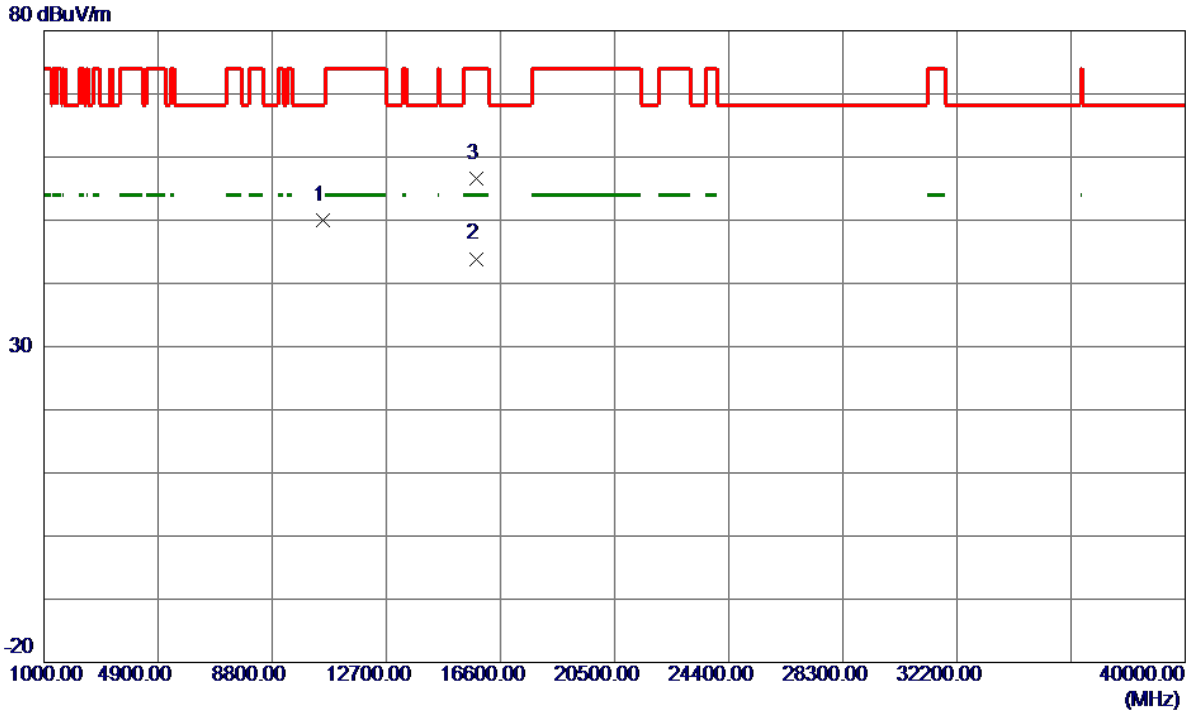

No.	Freq. MHz	Reading Level dBuV/m	Correct Factor dB	Measure ment dBuV/m	Limit dBuV/m	Margin dB	Detector	Comment
1	10524.2200	33.28	16.67	49.95	68.30	-18.35	Peak	
2 *	15774.9200	20.50	23.40	43.90	54.00	-10.10	AVG	
3	15783.6600	33.13	23.40	56.53	74.00	-17.47	Peak	

Orthogonal Axis :	X
Test Mode :	UNII-2A/ TX A Mode 5260MHz_ANT2

**Vertical**

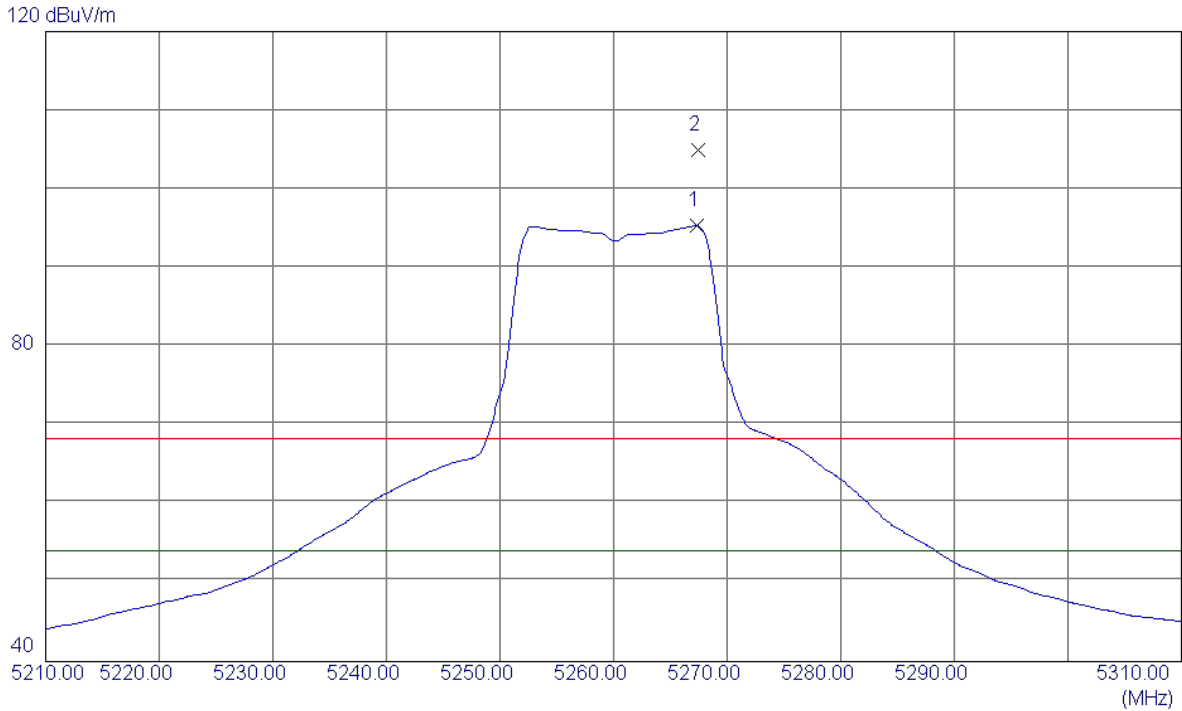

No.	Freq. MHz	Reading Level dBuV/m	Correct Factor dB	Measure ment dBuV/m	Limit dBuV/m	Margin dB	Detector	Comment
1 *	5267.3000	54.52	40.79	95.31	54.00	41.31	AVG	NO LIMIT
2	5267.4000	64.17	40.79	104.96	68.30	36.66	Peak	NO LIMIT

Remark: This test data is from original report BTL-FCCP-4-1602C038.

Orthogonal Axis :	X
Test Mode :	UNII-2A/ TX A Mode 5260MHz_ANT2

**Vertical**

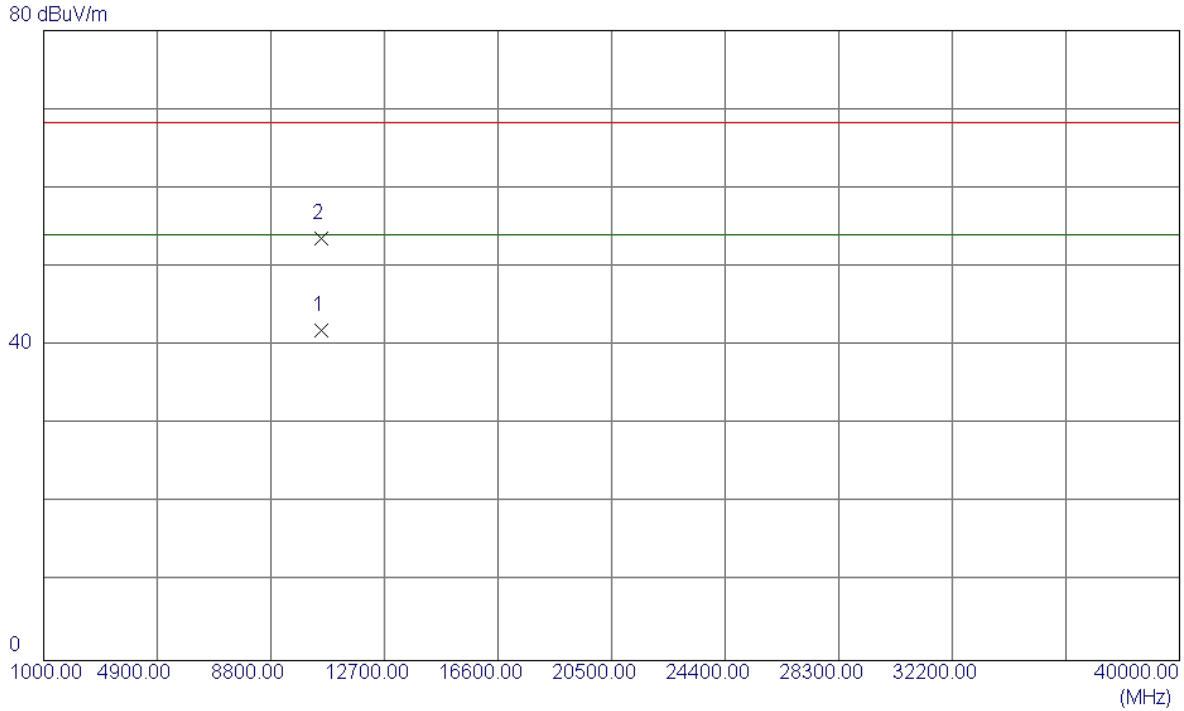

No.	Freq. MHz	Reading Level dBuV/m	Correct Factor dB	Measure ment dBuV/m	Limit dBuV/m	Margin dB	Detector	Comment
1 *	10521.1200	27.34	14.65	41.99	54.00	-12.01	AVG	
2	10521.1300	38.97	14.65	53.62	68.30	-14.68	Peak	

Remark: This test data is from original report BTL-FCCP-4-1602C038.

Orthogonal Axis :	X
Test Mode :	UNII-2A/ TX A Mode 5260MHz_ANT2

**Horizontal**

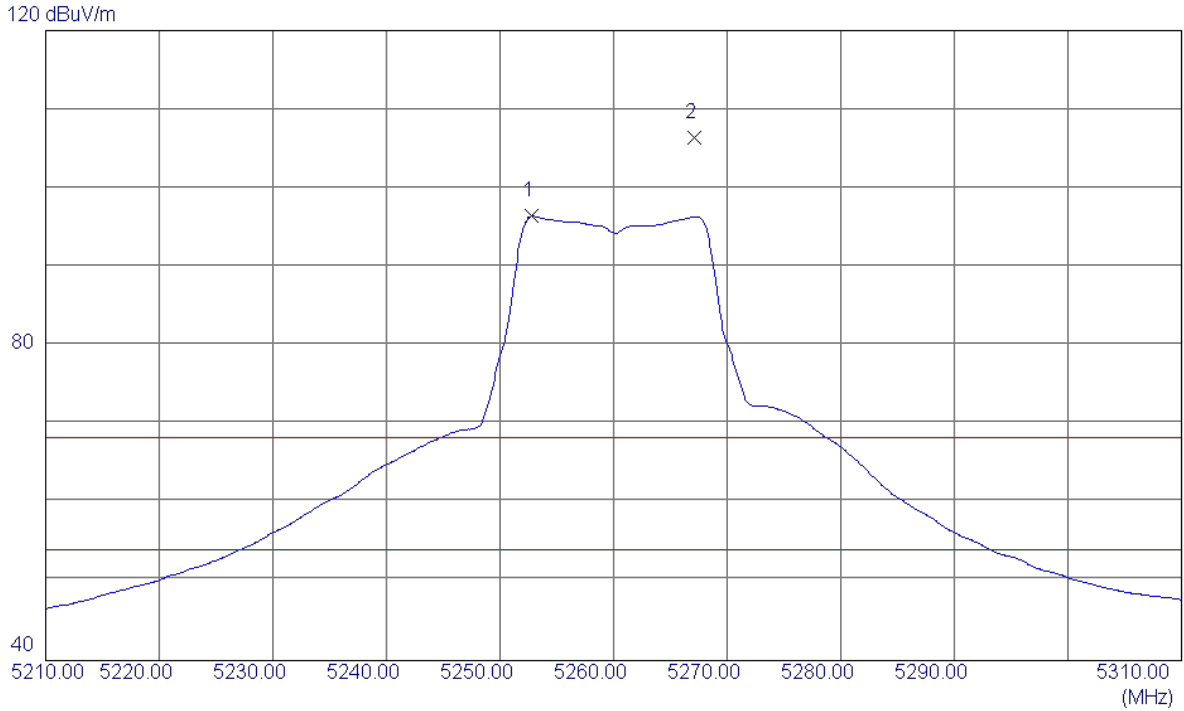

No.	Freq. MHz	Reading Level dBuV/m	Correct Factor dB	Measure ment dBuV/m	Limit dBuV/m	Margin dB	Detector	Comment
1 *	5252.8000	55.68	40.74	96.42	54.00	42.42	AVG	NO LIMIT
2	5267.1000	65.68	40.79	106.47	68.30	38.17	Peak	NO LIMIT

Remark: This test data is from original report BTL-FCCP-4-1602C038.

Orthogonal Axis :	X
Test Mode :	UNII-2A/ TX A Mode 5260MHz_ANT2

**Horizontal**

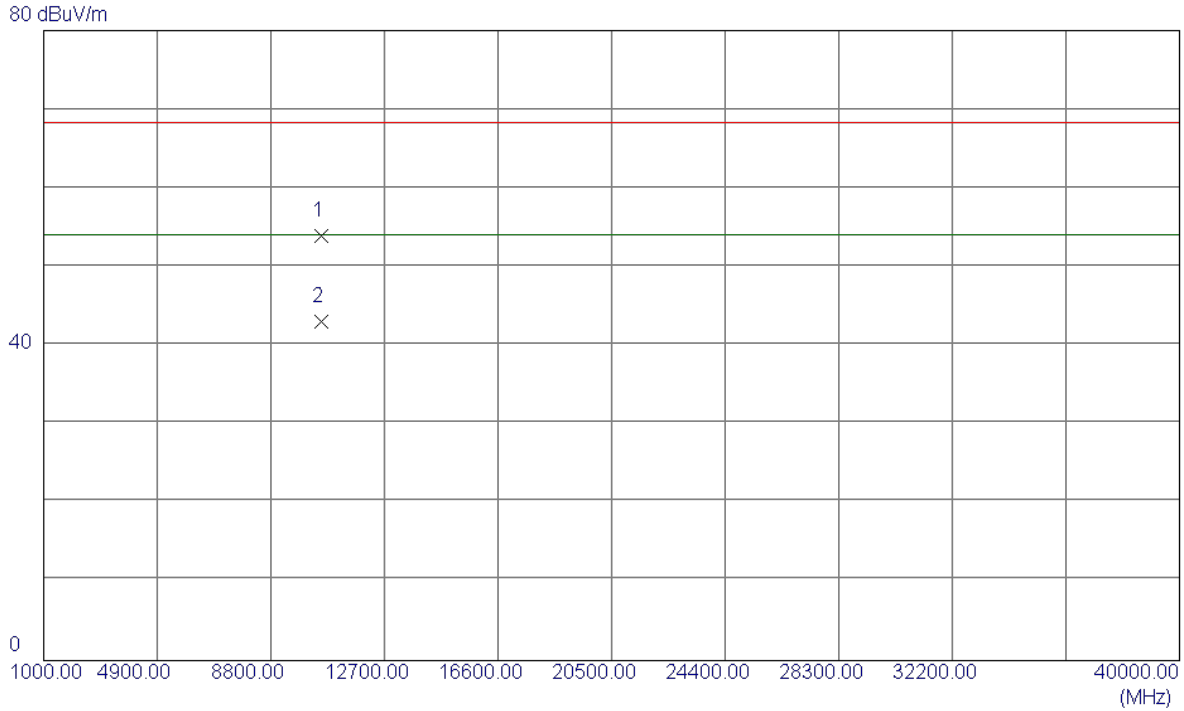

No.	Freq. MHz	Reading Level dBuV/m	Correct Factor dB	Measure ment dBuV/m	Limit dBuV/m	Margin dB	Detector	Comment
1	10520.9800	39.23	14.65	53.88	68.30	-14.42	Peak	
2 *	10521.0400	28.33	14.65	42.98	54.00	-11.02	AVG	

Remark: This test data is from original report BTL-FCCP-4-1602C038.

Orthogonal Axis :	X
Test Mode :	UNII-2A/ TX A Mode 5300MHz_ANT1

**Vertical**

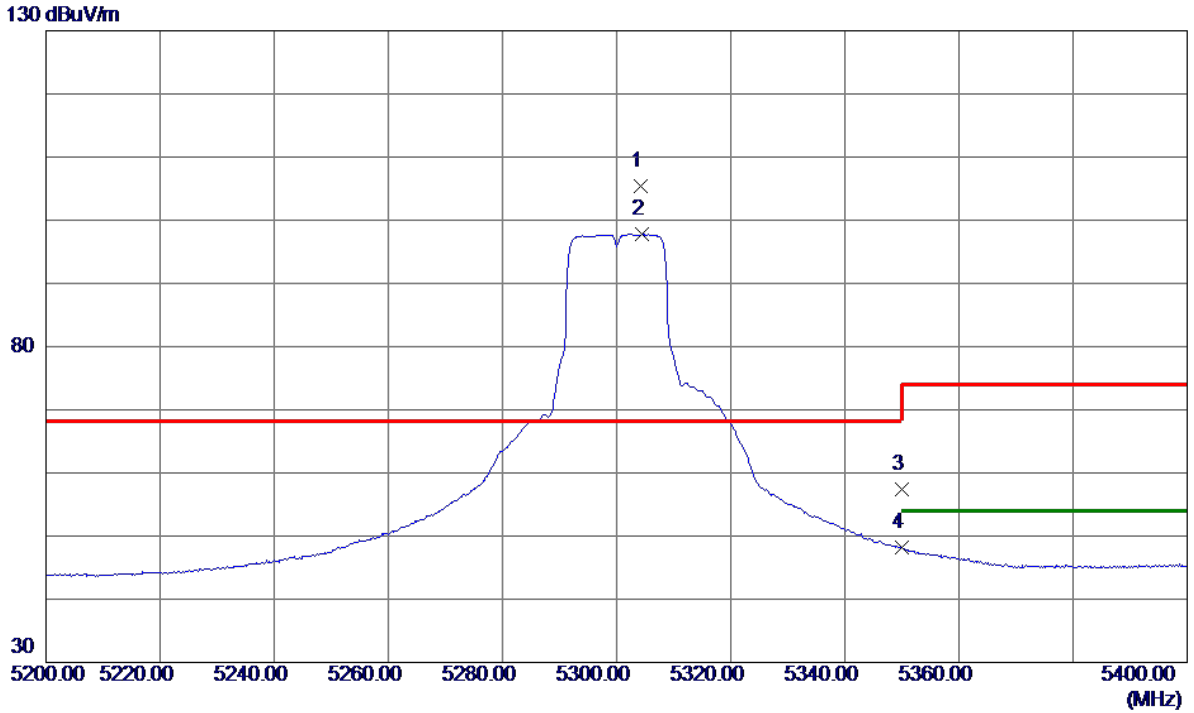

No.	Freq. MHz	Reading Level dBuV/m	Correct Factor dB	Measure ment dBuV/m	Limit dBuV/m	Margin dB	Detector	Comment
1 *	5304.2000	86.32	19.12	105.44	68.30	37.14	Peak	No Limit
2	5304.4000	78.67	19.13	97.80	999.00	-901.20	AVG	No Limit
3	5350.0000	38.01	19.40	57.41	74.00	-16.59	Peak	
4	5350.0000	28.71	19.40	48.11	999.00	-950.89	AVG	

Orthogonal Axis :	X
Test Mode :	UNII-2A/ TX A Mode 5300MHz_ANT1

**Vertical**

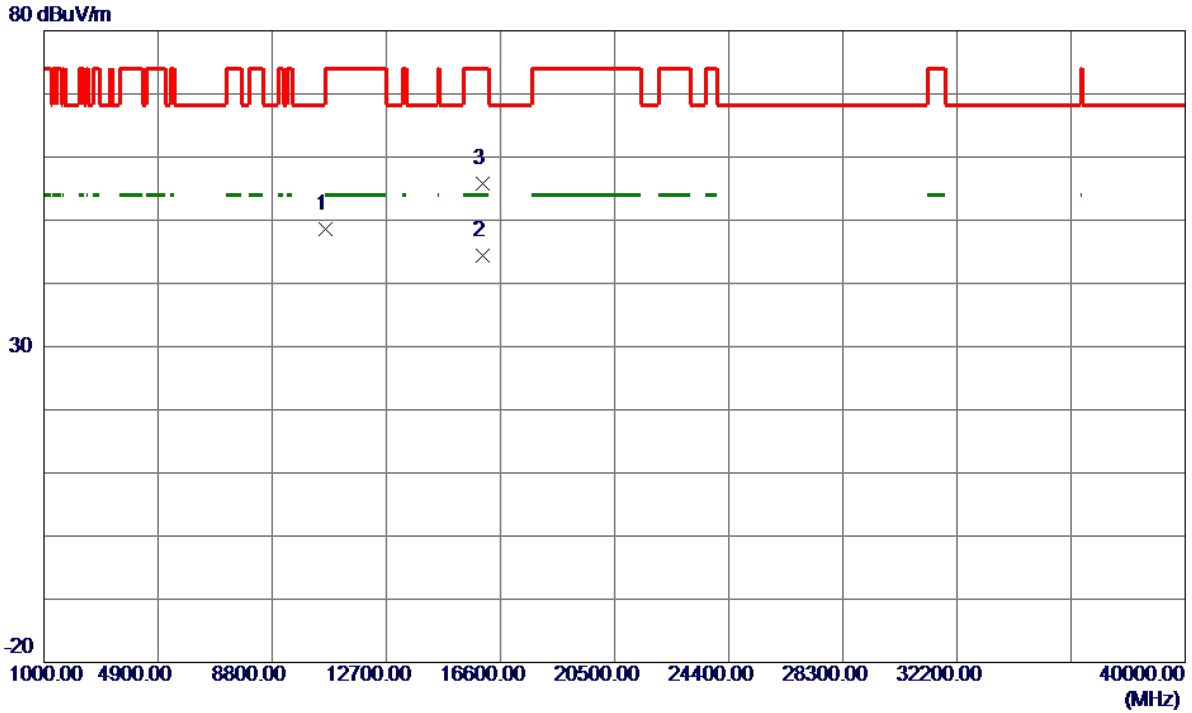

No.	Freq. MHz	Reading Level dBuV/m	Correct Factor dB	Measure ment dBuV/m	Limit dBuV/m	Margin dB	Detector	Comment
1	10598.9500	32.07	16.57	48.64	68.30	-19.66	Peak	
2 *	15985.0500	20.94	23.51	44.45	54.00	-9.55	AVG	
3	15985.7500	32.36	23.51	55.87	74.00	-18.13	Peak	

Orthogonal Axis :	X
Test Mode :	UNII-2A/ TX A Mode 5300MHz_ANT1

**Horizontal**

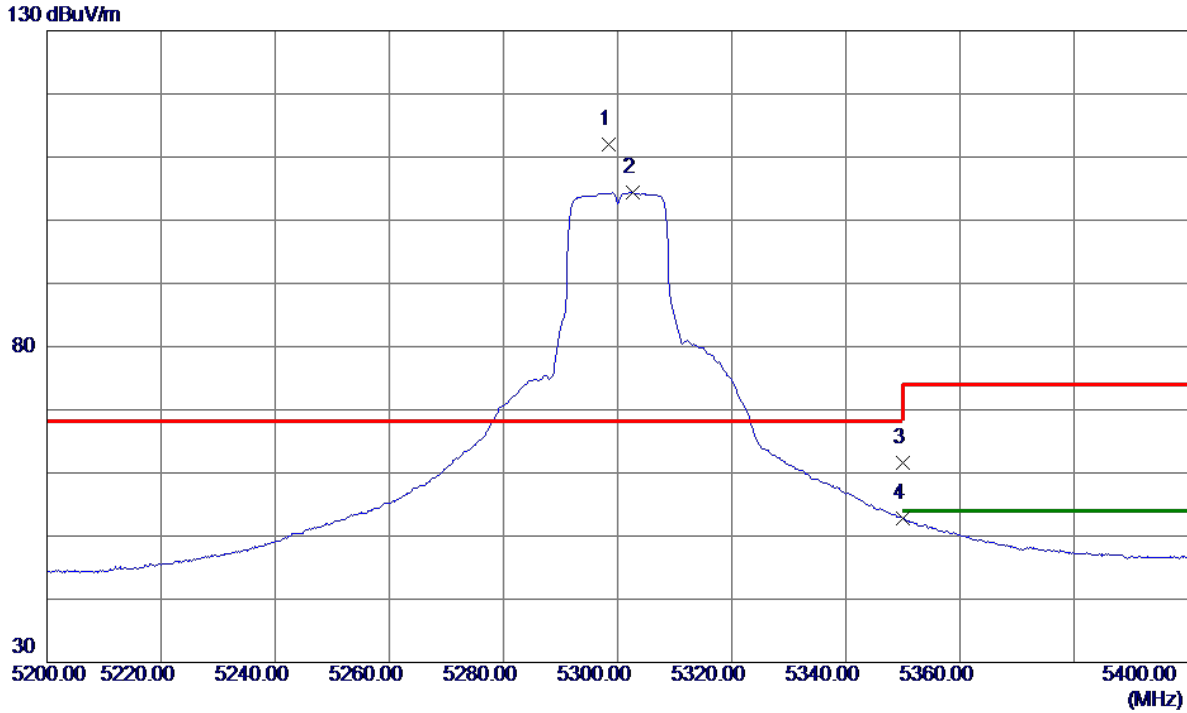

No.	Freq. MHz	Reading Level dBuV/m	Correct Factor dB	Measure ment dBuV/m	Limit dBuV/m	Margin dB	Detector	Comment
1 *	5298.4000	93.01	19.09	112.10	68.30	43.80	Peak	No Limit
2	5302.6000	85.23	19.11	104.34	999.00	-894.66	AVG	No Limit
3	5355.0000	42.27	19.40	61.67	74.00	-12.33	Peak	
4	5355.0000	33.47	19.40	52.87	999.00	-946.13	AVG	



Orthogonal Axis :	X
Test Mode :	UNII-2A/ TX A Mode 5300MHz_ANT1

**Horizontal**

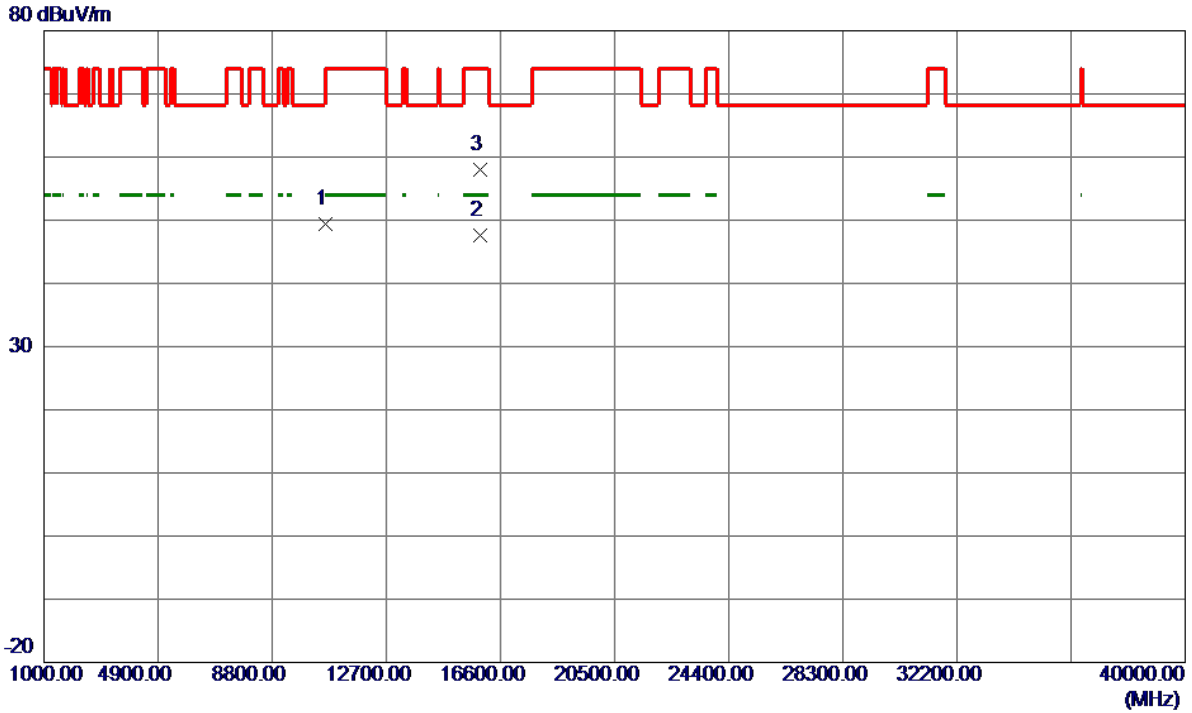

No.	Freq. MHz	Reading Level dBuV/m	Correct Factor dB	Measure ment dBuV/m	Limit dBuV/m	Margin dB	Detector	Comment
1	10605.2500	32.82	16.56	49.38	74.00	-24.62	Peak	
2 *	15900.8000	24.18	23.47	47.65	54.00	-6.35	AVG	
3	15907.8500	34.53	23.47	58.00	74.00	-16.00	Peak	

Orthogonal Axis :	X
Test Mode :	UNII-2A/ TX A Mode 5300MHz_ANT2

**Vertical**

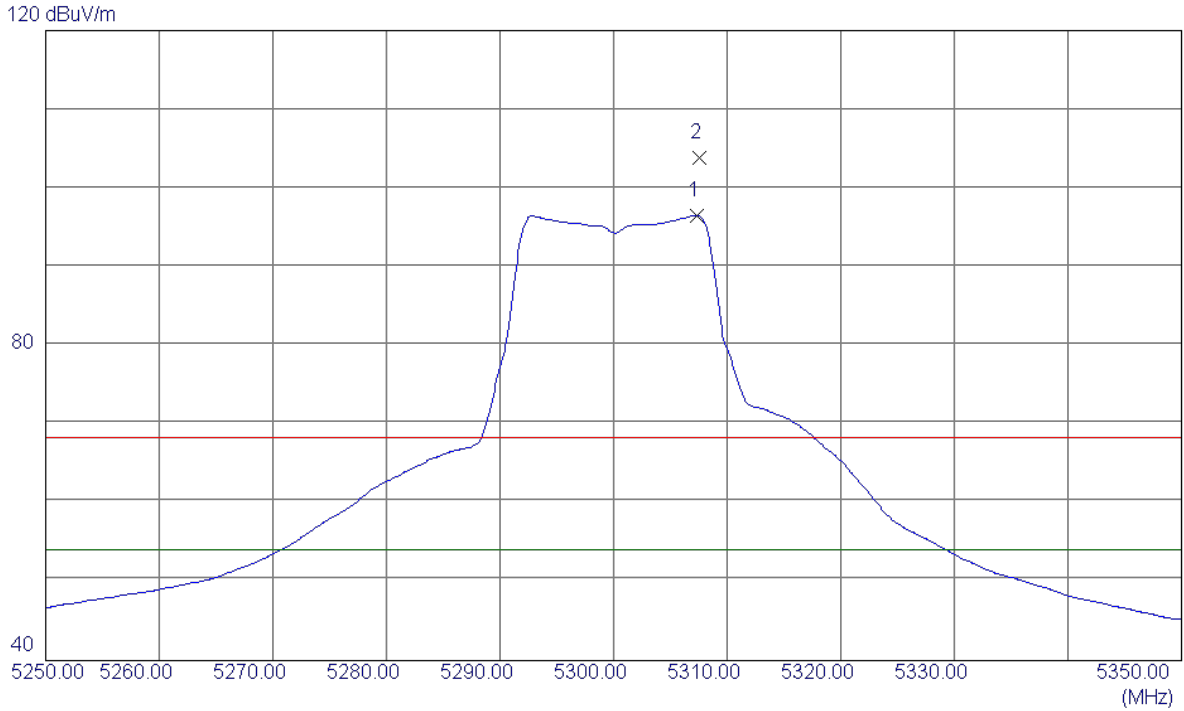

No.	Freq. MHz	Reading Level dBuV/m	Correct Factor dB	Measure ment dBuV/m	Limit dBuV/m	Margin dB	Detector	Comment
1 *	5307.3000	55.63	40.92	96.55	54.00	42.55	AVG	NO LIMIT
2	5307.6000	62.93	40.92	103.85	68.30	35.55	Peak	NO LIMIT

Remark: This test data is from original report BTL-FCCP-4-1602C038.

Orthogonal Axis :	X
Test Mode :	UNII-2A/ TX A Mode 5300MHz_ANT2

**Vertical**

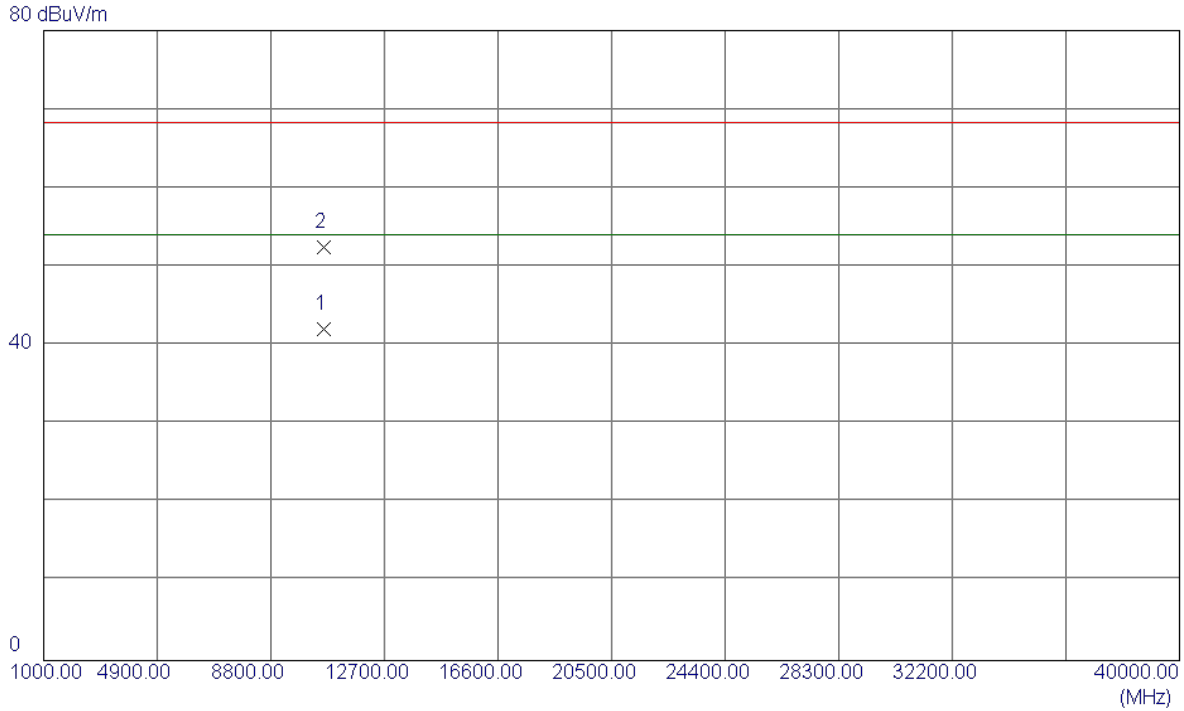

No.	Freq. MHz	Reading Level dBuV/m	Correct Factor dB	Measure ment dBuV/m	Limit dBuV/m	Margin dB	Detector	Comment
1 *	10600.3400	27.25	14.89	42.14	54.00	-11.86	AVG	
2	10600.5100	37.55	14.89	52.44	68.30	-15.86	Peak	

Remark: This test data is from original report BTL-FCCP-4-1602C038.

Orthogonal Axis :	X
Test Mode :	UNII-2A/ TX A Mode 5300MHz_ANT2

**Horizontal**

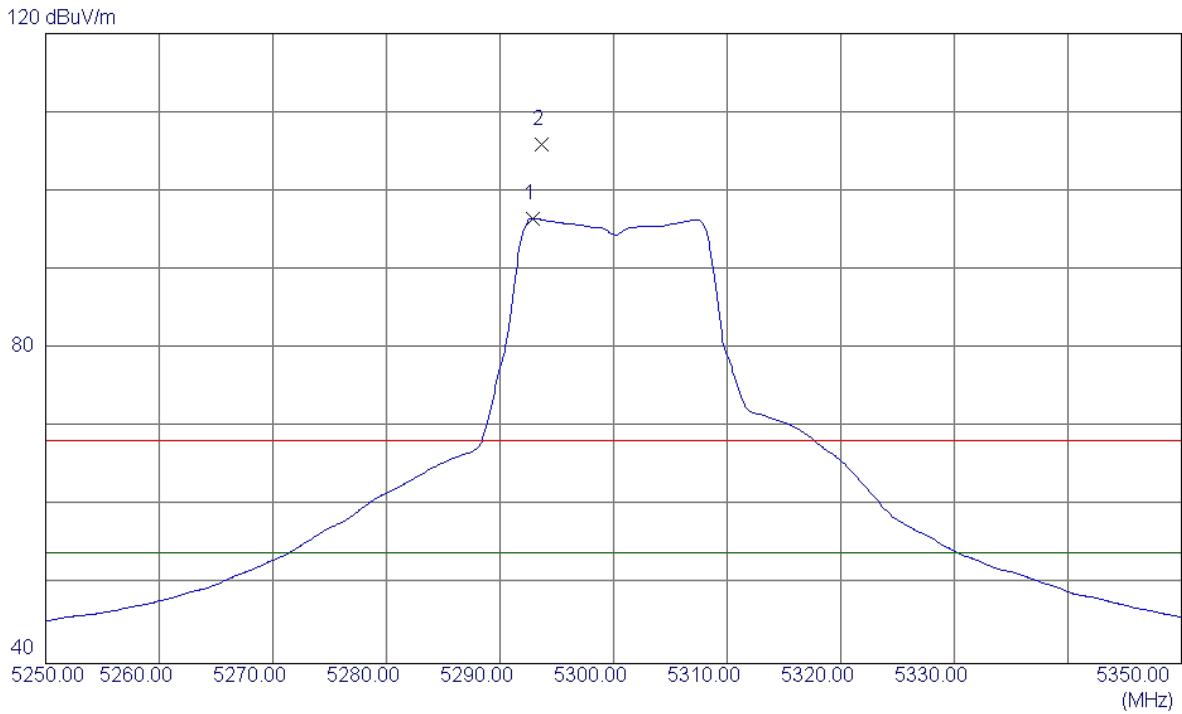

No.	Freq. MHz	Reading Level dBuV/m	Correct Factor dB	Measure ment dBuV/m	Limit dBuV/m	Margin dB	Detector	Comment
1 *	5292.9000	55.66	40.88	96.54	54.00	42.54	AVG	NO LIMIT
2	5293.7000	65.08	40.88	105.96	68.30	37.66	Peak	NO LIMIT

Remark: This test data is from original report BTL-FCCP-4-1602C038.

Orthogonal Axis :	X
Test Mode :	UNII-2A/ TX A Mode 5300MHz_ANT2

**Horizontal**

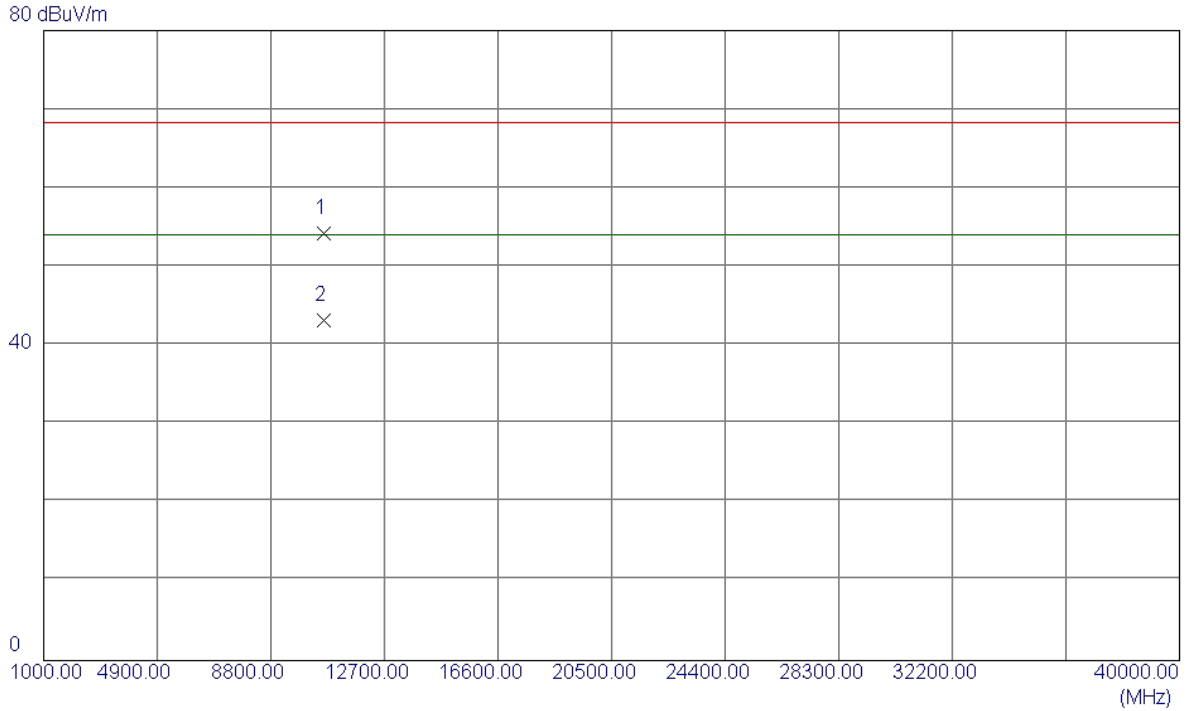

No.	Freq. MHz	Reading Level dBuV/m	Correct Factor dB	Measure ment dBuV/m	Limit dBuV/m	Margin dB	Detector	Comment
1	10600.4600	39.28	14.89	54.17	68.30	-14.13	Peak	
2 *	10601.5210	28.26	14.89	43.15	54.00	-10.85	AVG	

Remark: This test data is from original report BTL-FCCP-4-1602C038.

Orthogonal Axis :	X
Test Mode :	UNII-2A/ TX A Mode 5320MHz_ANT1

**Vertical**

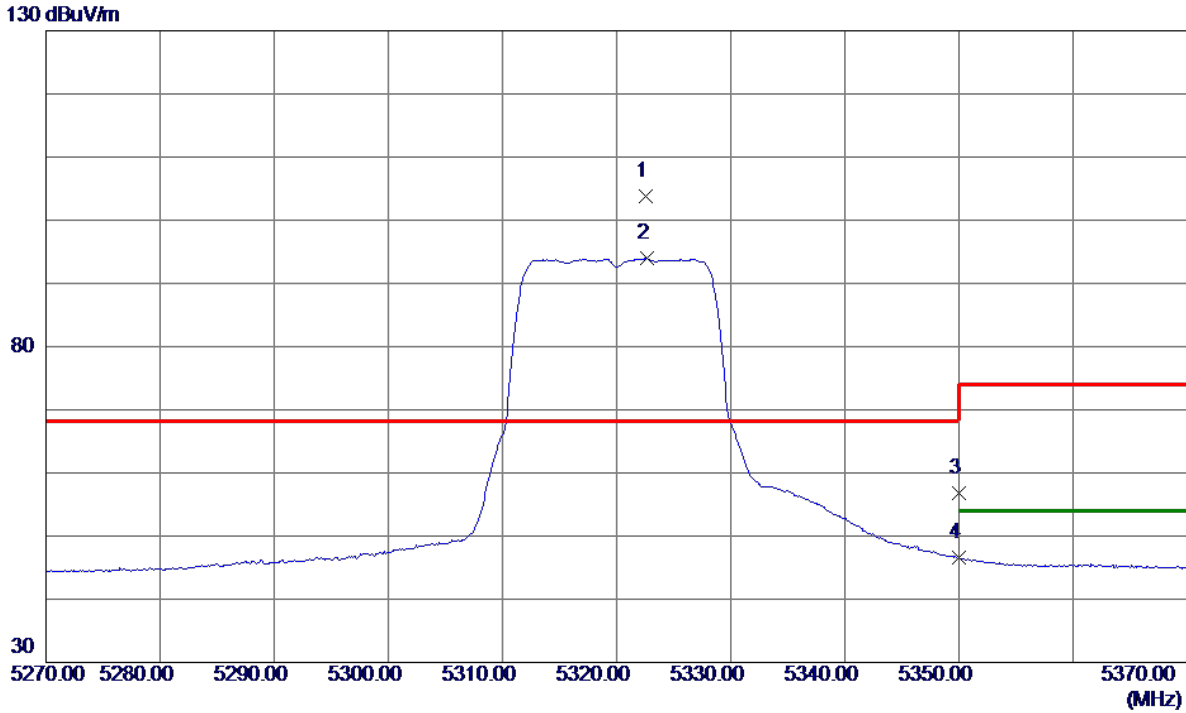

No.	Freq. MHz	Reading Level dBuV/m	Correct Factor dB	Measure ment dBuV/m	Limit dBuV/m	Margin dB	Detector	Comment
1 *	5322.6000	84.54	19.24	103.78	68.30	35.48	Peak	No Limit
2	5322.7000	74.71	19.24	93.95	999.00	-905.05	AVG	No Limit
3	5350.0000	37.31	19.40	56.71	74.00	-17.29	Peak	
4	5350.0000	27.24	19.40	46.64	999.00	-952.36	AVG	

Orthogonal Axis :	X
Test Mode :	UNII-2A/ TX A Mode 5320MHz_ANT1

**Vertical**

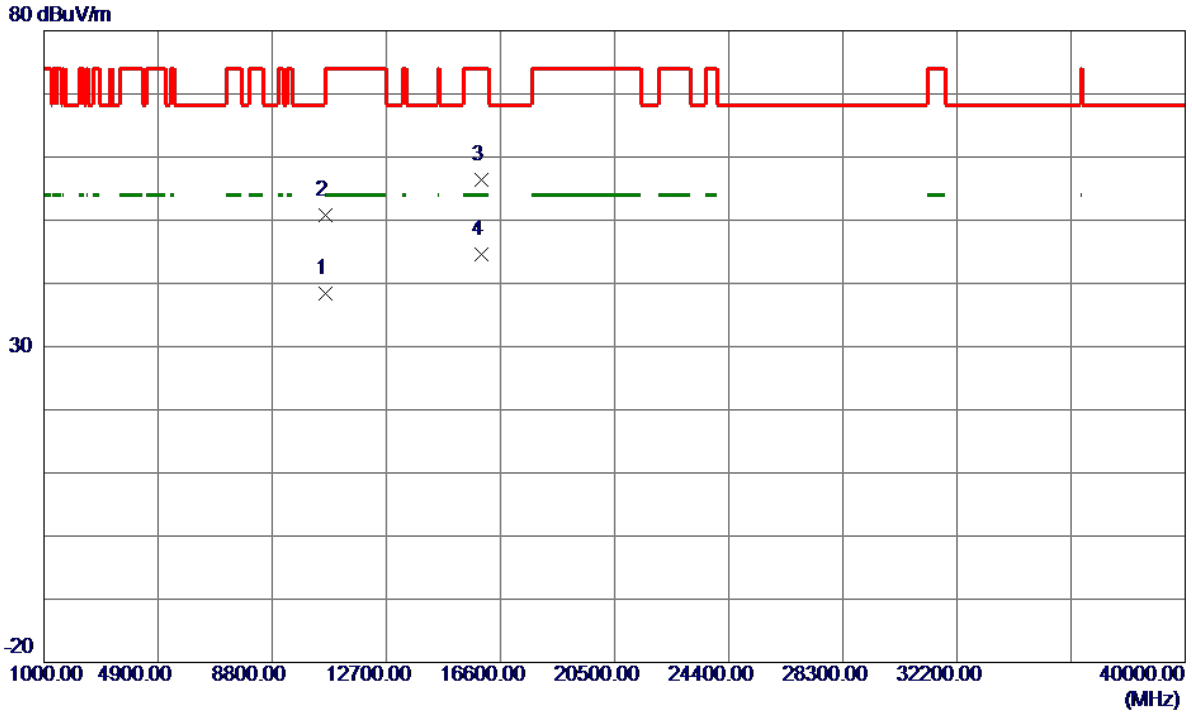

No.	Freq. MHz	Reading Level dBuV/m	Correct Factor dB	Measurement dBuV/m	Limit dBuV/m	Margin dB	Detector	Comment
1	10636.0900	21.86	16.52	38.38	54.00	-15.62	AVG	
2	10636.4300	34.32	16.52	50.84	74.00	-23.16	Peak	
3	15957.7900	32.81	23.50	56.31	74.00	-17.69	Peak	
4 *	15961.1600	21.05	23.50	44.55	54.00	-9.45	AVG	

Orthogonal Axis :	X
Test Mode :	UNII-2A/ TX A Mode 5320MHz_ANT1

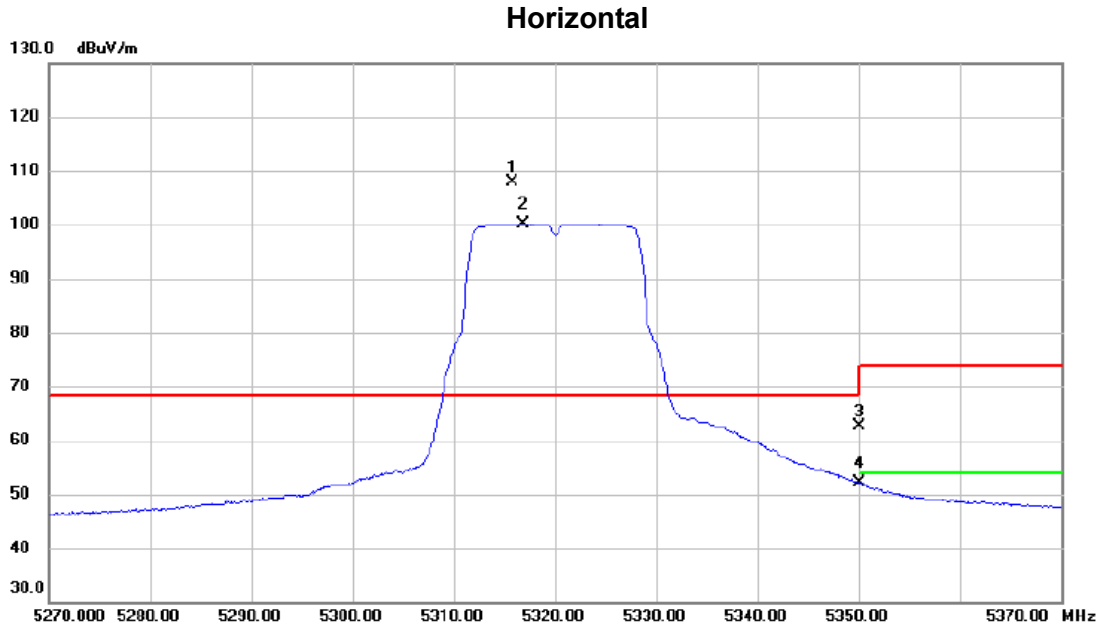

No.	Mk.	Freq. MHz	Reading Level dBuV	Correct Factor dB	Measure- ment dBuV/m	Limit dBuV/m	Margin dB	Detector	Comment
1	*	5315.800	88.69	19.19	107.88	68.30	39.58	peak	No Limit
2	X	5316.900	80.86	19.20	100.06	68.30	31.76	AVG	No Limit
3		5350.000	43.33	19.40	62.73	74.00	-11.27	peak	
4		5350.000	32.85	19.40	52.25	54.00	-1.75	AVG	



Orthogonal Axis :	X
Test Mode :	UNII-2A/ TX A Mode 5320MHz_ANT1

**Horizontal**

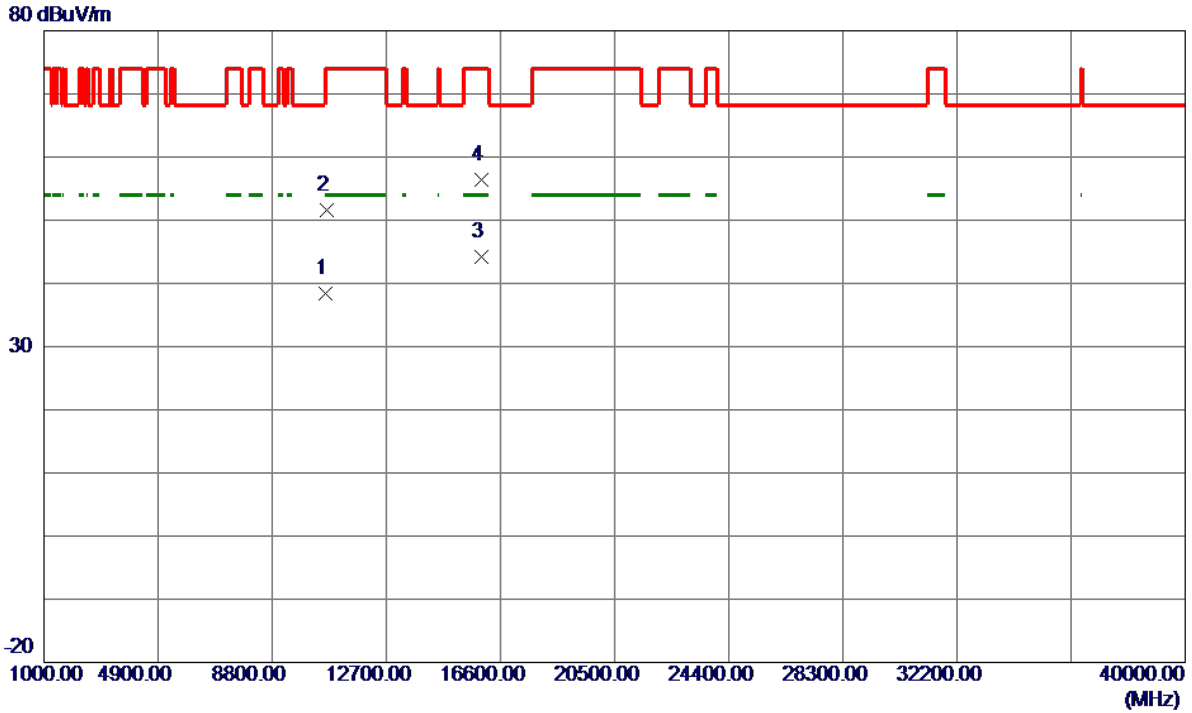

No.	Freq. MHz	Reading Level dBuV/m	Correct Factor dB	Measure ment dBuV/m	Limit dBuV/m	Margin dB	Detector	Comment
1	10635.6900	21.96	16.52	38.48	54.00	-15.52	AVG	
2	10644.3000	35.00	16.51	51.51	74.00	-22.49	Peak	
3 *	15950.0600	20.70	23.49	44.19	54.00	-9.81	AVG	
4	15952.8600	32.92	23.49	56.41	74.00	-17.59	Peak	

Orthogonal Axis :	X
Test Mode :	UNII-2A/ TX A Mode 5320MHz_ANT2

**Vertical**

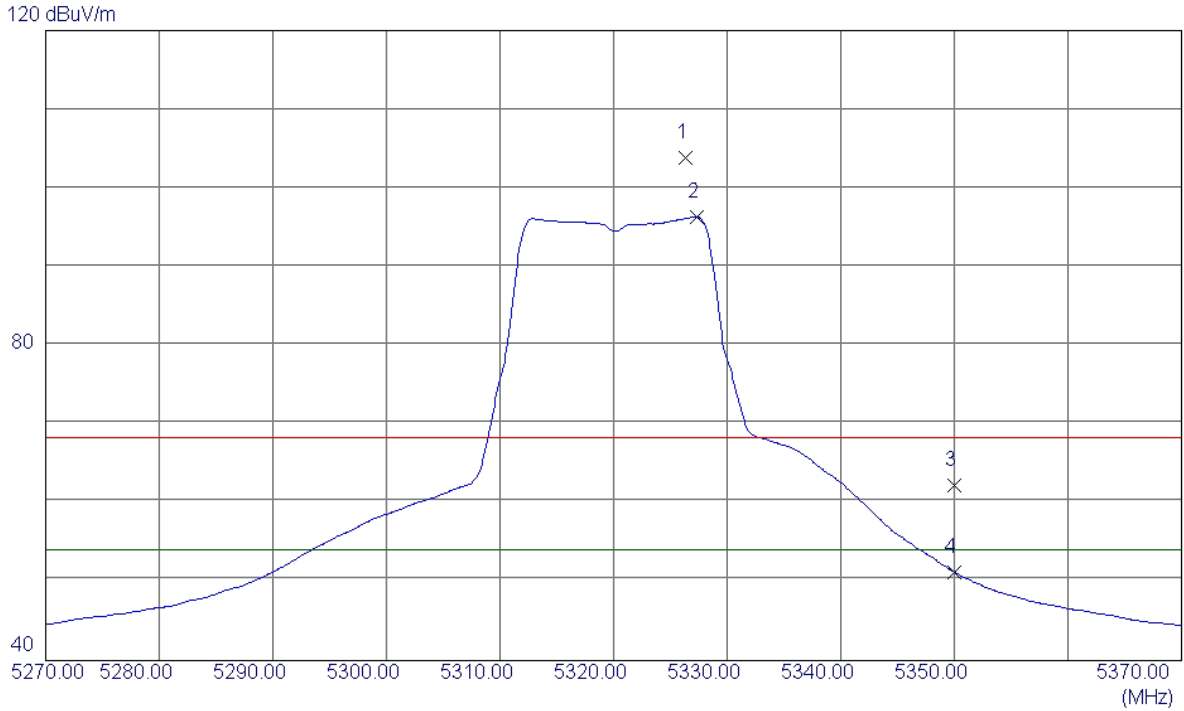

No.	Freq. MHz	Reading Level dBuV/m	Correct Factor dB	Measure ment dBuV/m	Limit dBuV/m	Margin dB	Detector	Comment
1	5326.3000	62.77	40.99	103.76	68.30	35.46	Peak	NO LIMIT
2 *	5327.3000	55.35	40.99	96.34	54.00	42.34	AVG	NO LIMIT
3	5350.0000	21.25	41.06	62.31	68.30	-5.99	Peak	
4	5350.0000	10.18	41.06	51.24	54.00	-2.76	AVG	

Remark: This test data is from original report BTL-FCCP-4-1602C038.

Orthogonal Axis :	X
Test Mode :	UNII-2A/ TX A Mode 5320MHz_ANT2

**Vertical**

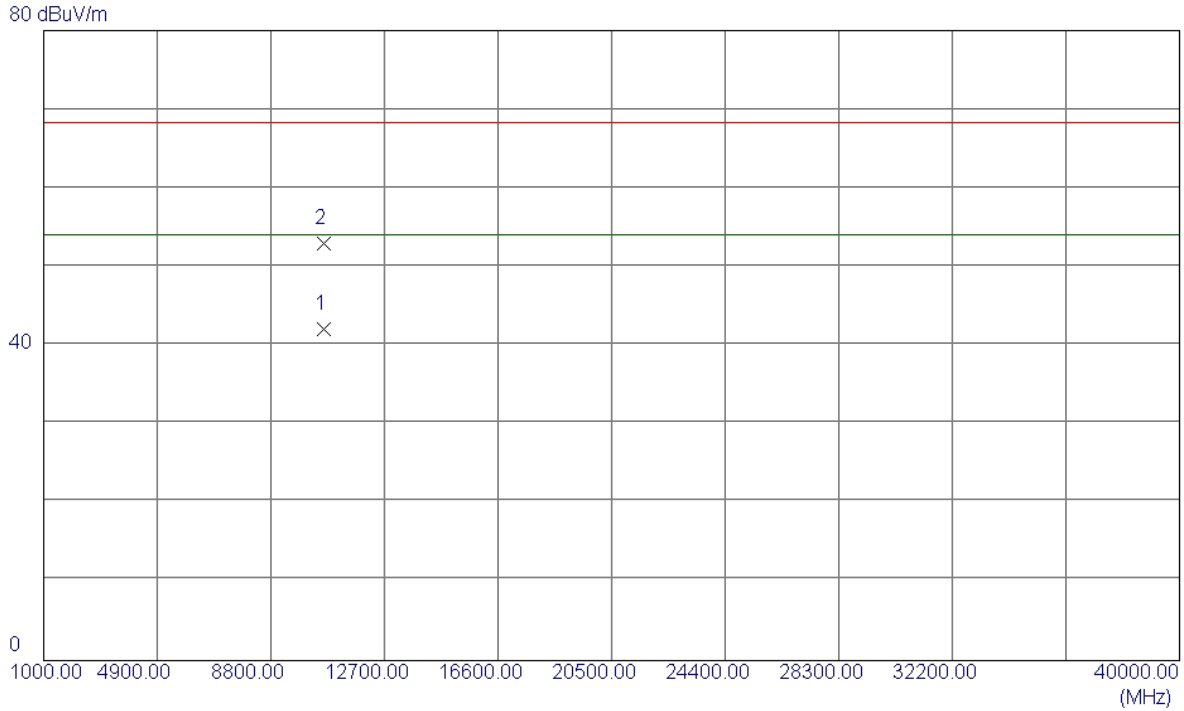

No.	Freq. MHz	Reading Level dBuV/m	Correct Factor dB	Measure ment dBuV/m	Limit dBuV/m	Margin dB	Detector	Comment
1 *	10640.4700	27.05	15.01	42.06	54.00	-11.94	AVG	
2	10640.5230	37.89	15.01	52.90	68.30	-15.40	Peak	

Remark: This test data is from original report BTL-FCCP-4-1602C038.

Orthogonal Axis :	X
Test Mode :	UNII-2A/ TX A Mode 5320MHz_ANT2

### Horizontal

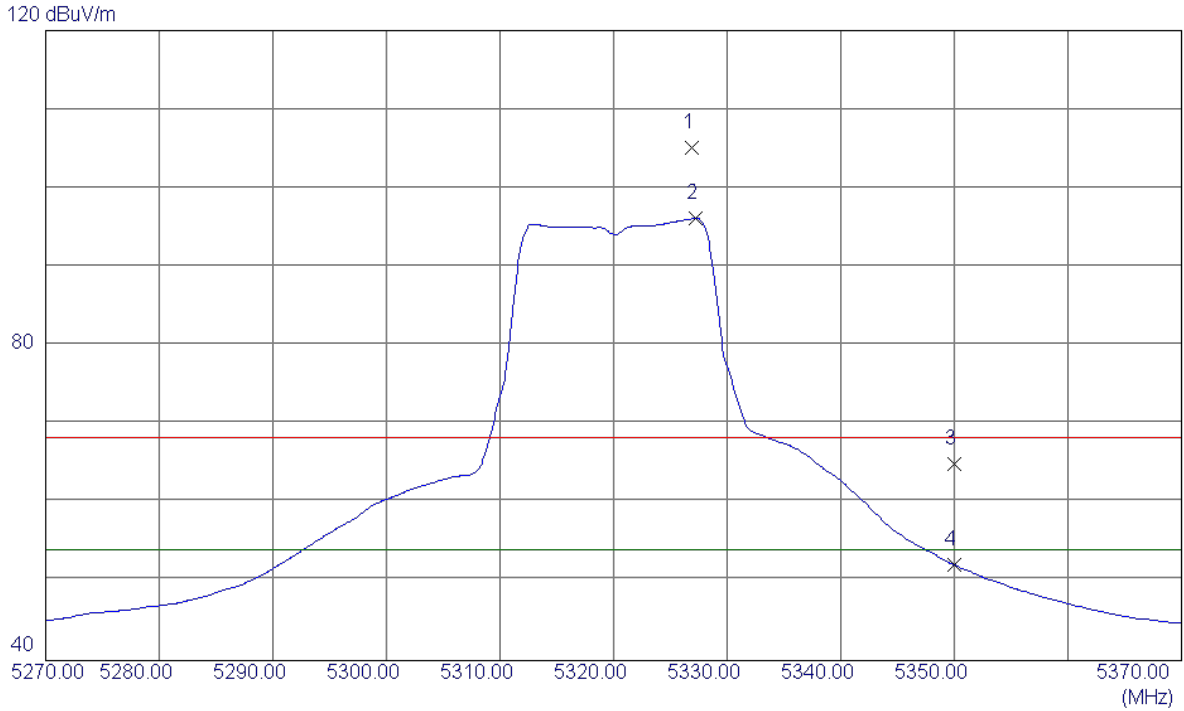

No.	Freq. MHz	Reading Level dBuV/m	Correct Factor dB	Measure ment dBuV/m	Limit dBuV/m	Margin dB	Detector	Comment
1	5326.9000	64.09	40.99	105.08	68.30	36.78	Peak	NO LIMIT
2 *	5327.2000	55.15	40.99	96.14	54.00	42.14	AVG	NO LIMIT
3	5350.0000	23.96	41.06	65.02	68.30	-3.28	Peak	
4	5350.0000	11.09	41.06	52.15	54.00	-1.85	AVG	

Remark: This test data is from original report BTL-FCCP-4-1602C038.

Orthogonal Axis :	X
Test Mode :	UNII-2A/ TX A Mode 5320MHz_ANT2

**Horizontal**

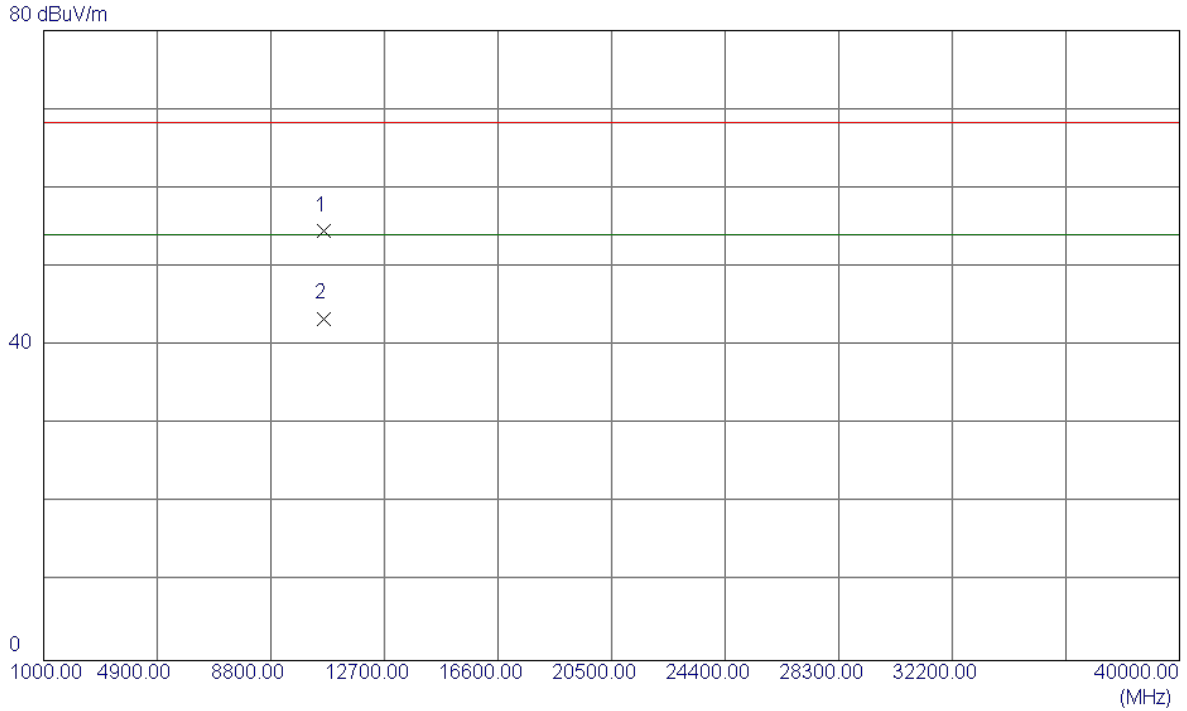

No.	Freq. MHz	Reading Level dBuV/m	Correct Factor dB	Measure ment dBuV/m	Limit dBuV/m	Margin dB	Detector	Comment
1	10640.1130	39.50	15.01	54.51	68.30	-13.79	Peak	
2 *	10640.3370	28.43	15.01	43.44	54.00	-10.56	AVG	

Remark: This test data is from original report BTL-FCCP-4-1602C038.

Orthogonal Axis :	X
Test Mode :	UNII-2A/ TX N20 Mode 5260MHz

**Vertical**

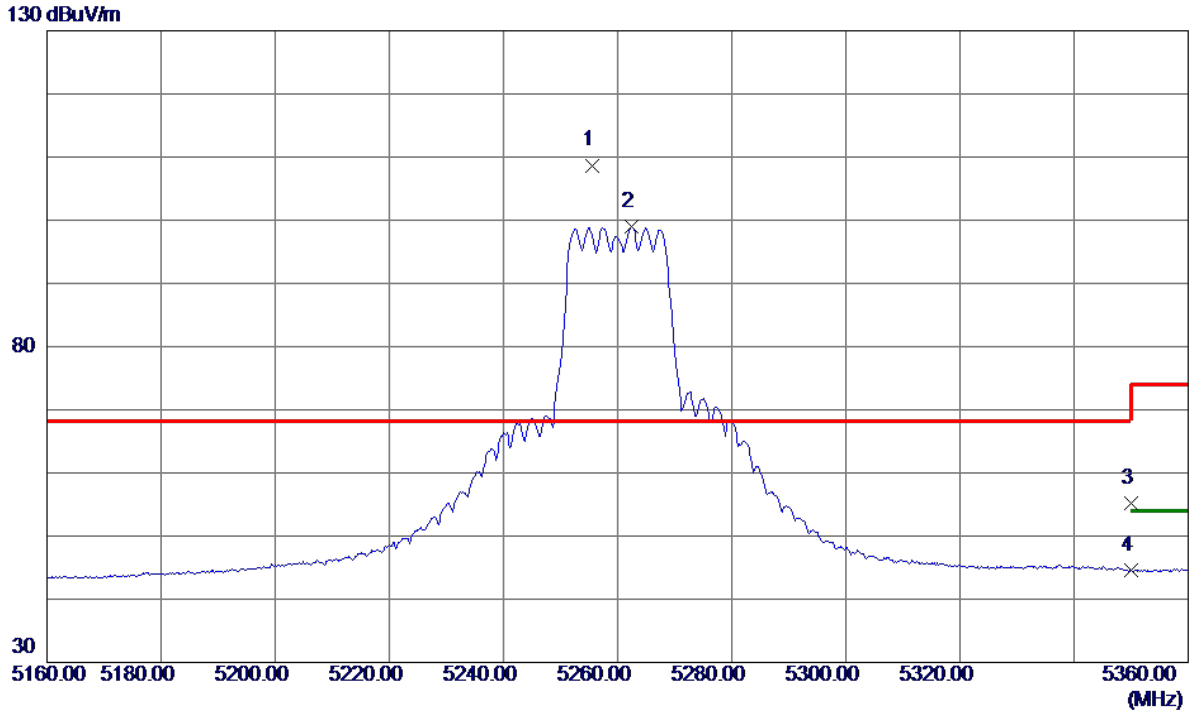

No.	Freq. MHz	Reading Level dBuV/m	Correct Factor dB	Measure ment dBuV/m	Limit dBuV/m	Margin dB	Detector	Comment
1 *	5255.6000	89.87	18.83	108.70	68.30	40.40	Peak	No Limit
2	5262.4000	80.17	18.87	99.04	999.00	-899.96	AVG	No Limit
3	5350.0000	35.86	19.40	55.26	74.00	-18.74	Peak	
4	5350.0000	25.14	19.40	44.54	999.00	-954.46	AVG	

Orthogonal Axis :	X
Test Mode :	UNII-2A/ TX N20 Mode 5260MHz

**Vertical**

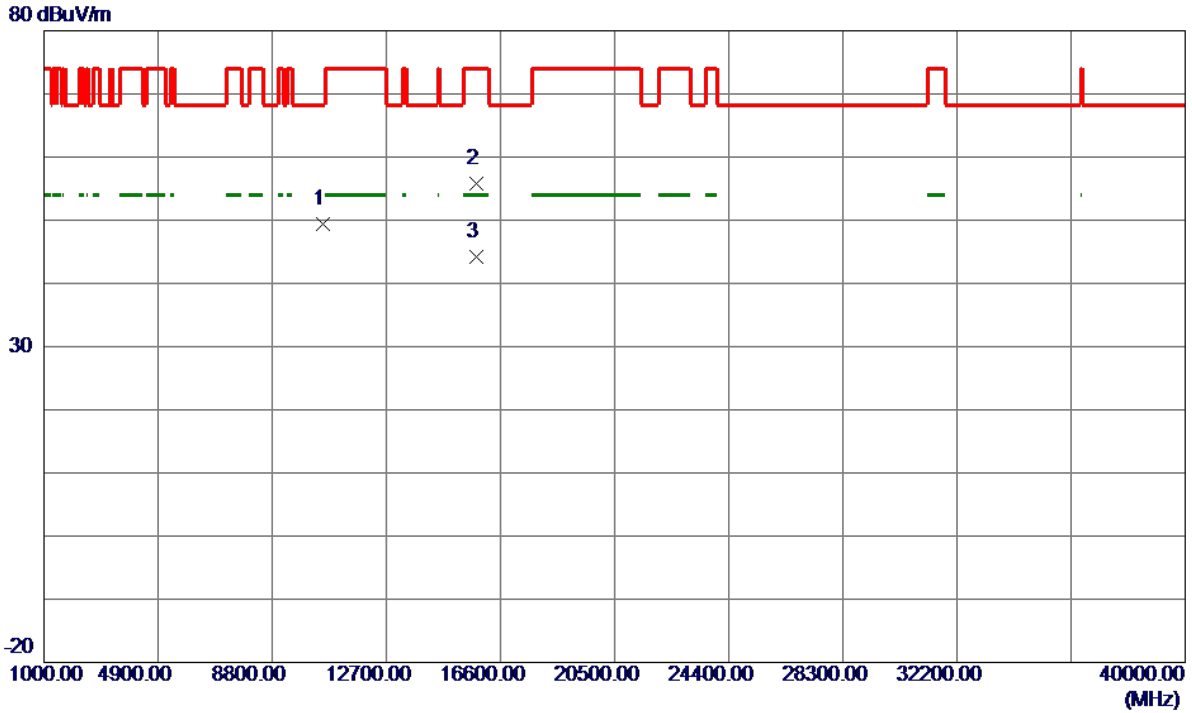

No.	Freq. MHz	Reading Level dBuV/m	Correct Factor dB	Measure ment dBuV/m	Limit dBuV/m	Margin dB	Detector	Comment
1	10516.2400	32.64	16.68	49.32	68.30	-18.98	Peak	
2	15775.1800	32.32	23.40	55.72	74.00	-18.28	Peak	
3 *	15783.3800	20.77	23.40	44.17	54.00	-9.83	AVG	

Orthogonal Axis :	X
Test Mode :	UNII-2A/ TX N20 Mode 5260MHz

**Horizontal**

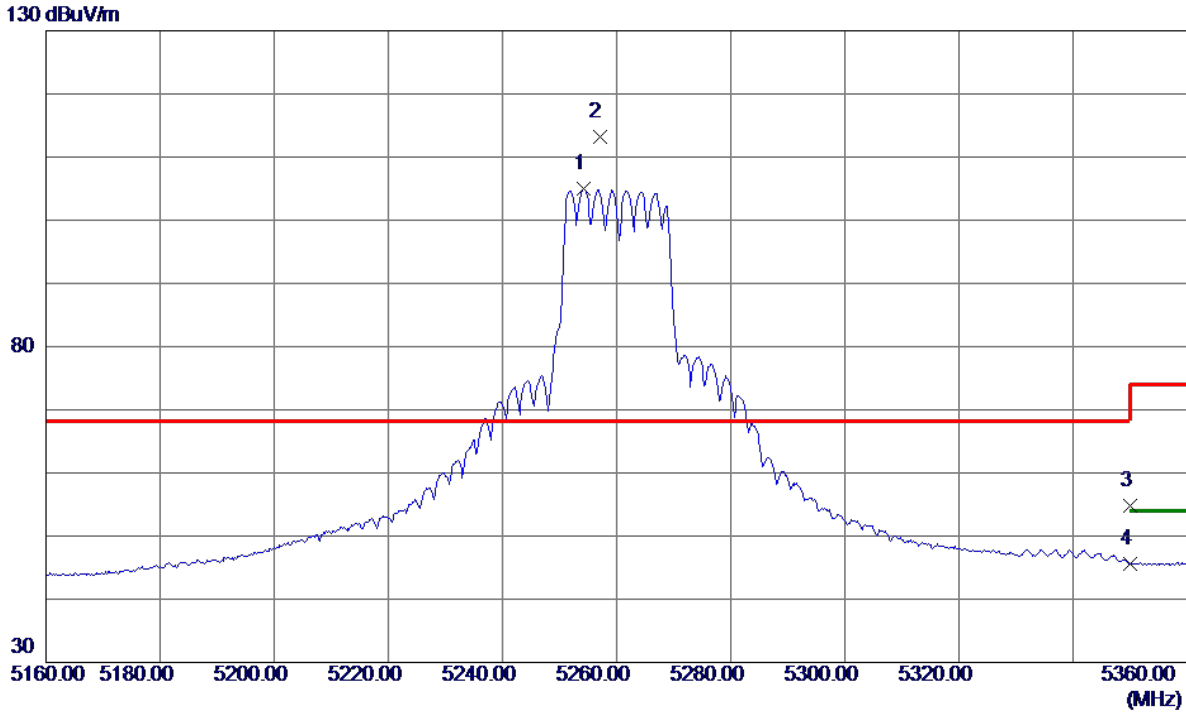

No.	Freq. MHz	Reading Level dBuV/m	Correct Factor dB	Measure ment dBuV/m	Limit dBuV/m	Margin dB	Detector	Comment
1	5254.2000	86.08	18.82	104.90	999.00	-894.10	AVG	No Limit
2 *	5257.0000	94.34	18.84	113.18	68.30	44.88	Peak	No Limit
3	5350.0000	35.46	19.40	54.86	74.00	-19.14	Peak	
4	5350.0000	26.29	19.40	45.69	999.00	-953.31	AVG	



Orthogonal Axis :	X
Test Mode :	UNII-2A/ TX N20 Mode 5260MHz

**Horizontal**

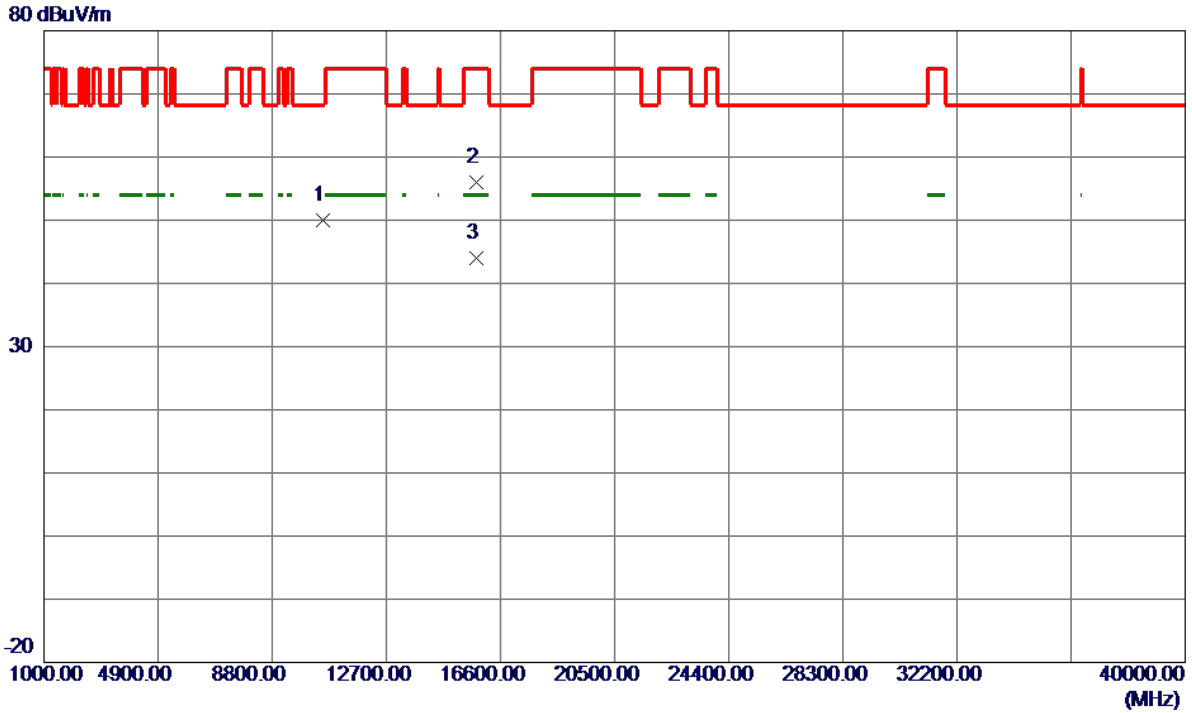

No.	Freq. MHz	Reading Level dBuV/m	Correct Factor dB	Measure ment dBuV/m	Limit dBuV/m	Margin dB	Detector	Comment
1	10518.2699	33.27	16.68	49.95	68.30	-18.35	Peak	
2	15779.6100	32.69	23.40	56.09	74.00	-17.91	Peak	
3 *	15782.0700	20.52	23.40	43.92	54.00	-10.08	AVG	

Orthogonal Axis :	X
Test Mode :	UNII-2A/ TX N20 Mode 5300MHz

**Vertical**

130 dBuV/m

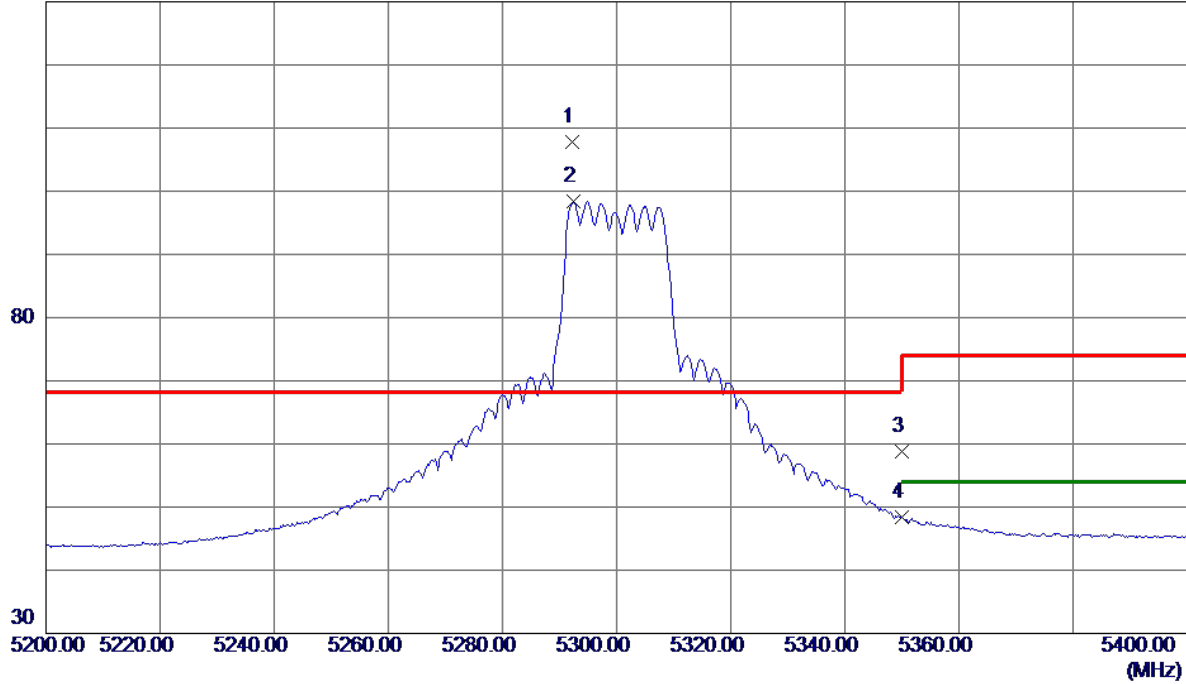

No.	Freq. MHz	Reading Level dBuV/m	Correct Factor dB	Measure ment dBuV/m	Limit dBuV/m	Margin dB	Detector	Comment
1 *	5292.2000	88.69	19.05	107.74	68.30	39.44	Peak	No Limit
2	5292.4000	79.39	19.05	98.44	999.00	-900.56	AVG	No Limit
3	5350.0000	39.40	19.40	58.80	74.00	-15.20	Peak	
4	5350.0000	28.98	19.40	48.38	999.00	-950.62	AVG	

Orthogonal Axis :	X
Test Mode :	UNII-2A/ TX N20 Mode 5300MHz

**Vertical**

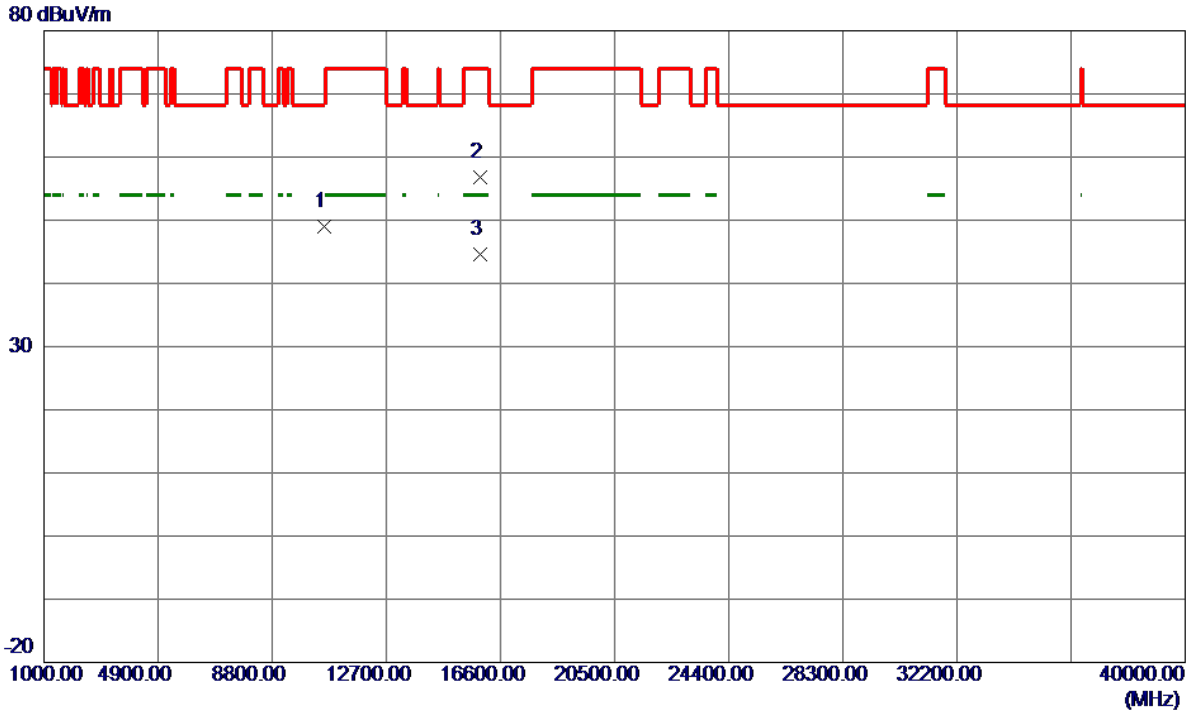

No.	Freq. MHz	Reading Level dBuV/m	Correct Factor dB	Measure ment dBuV/m	Limit dBuV/m	Margin dB	Detector	Comment
1	10596.9800	32.36	16.57	48.93	68.30	-19.37	Peak	
2	15898.8100	33.39	23.46	56.85	74.00	-17.15	Peak	
3 *	15902.8900	21.11	23.47	44.58	54.00	-9.42	AVG	

Orthogonal Axis :	X
Test Mode :	UNII-2A/ TX N20 Mode 5300MHz

**Horizontal**

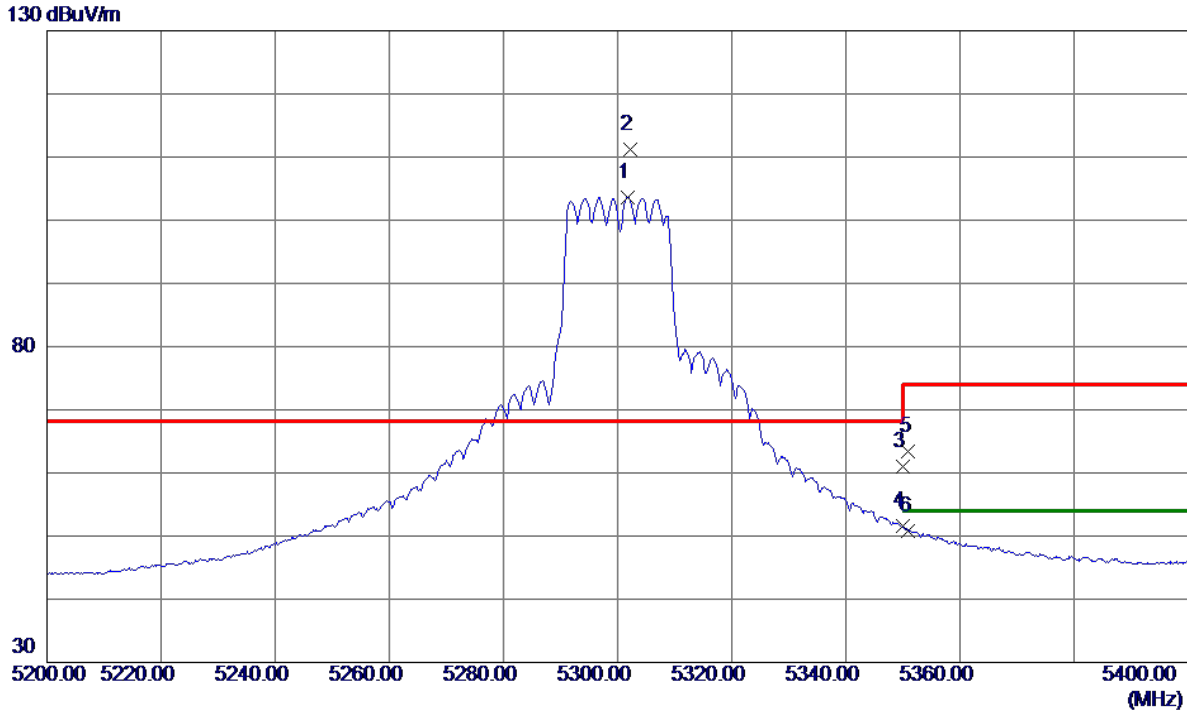

No.	Freq. MHz	Reading Level dBuV/m	Correct Factor dB	Measure ment dBuV/m	Limit dBuV/m	Margin dB	Detector	Comment
1	5301.8000	84.54	19.11	103.65	999.00	-895.35	AVG	No Limit
2 *	5302.2000	92.06	19.11	111.17	68.30	42.87	Peak	No Limit
3	5350.0000	41.59	19.40	60.99	74.00	-13.01	Peak	
4	5350.0000	32.21	19.40	51.61	999.00	-947.39	AVG	
5	5351.0000	43.94	19.41	63.35	74.00	-10.65	Peak	
6	5351.0000	31.38	19.41	50.79	54.00	-3.21	AVG	

Orthogonal Axis :	X
Test Mode :	UNII-2A/ TX N20 Mode 5300MHz

**Horizontal**

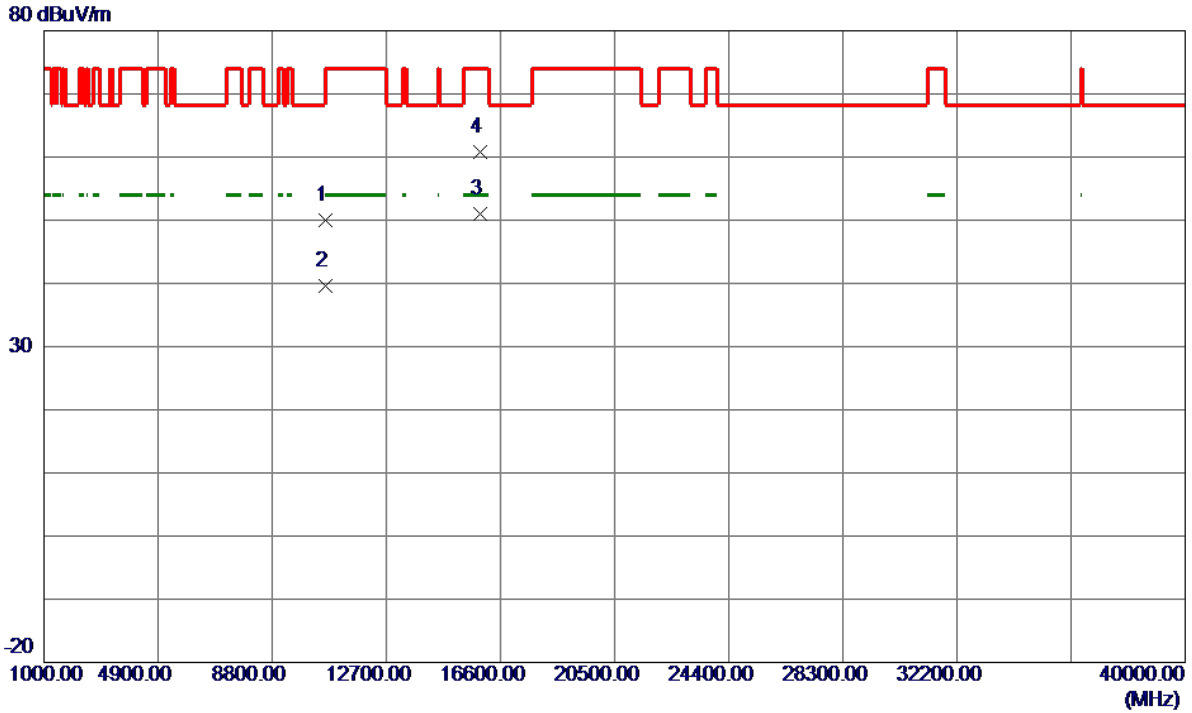

No.	Freq. MHz	Reading Level dBuV/m	Correct Factor dB	Measure ment dBuV/m	Limit dBuV/m	Margin dB	Detector	Comment
1	10600.3000	33.42	16.57	49.99	74.00	-24.01	Peak	
2	10600.6000	23.00	16.57	39.57	54.00	-14.43	AVG	
3 *	15895.5000	27.59	23.46	51.05	54.00	-2.95	AVG	
4	15903.9000	37.39	23.47	60.86	74.00	-13.14	Peak	

Orthogonal Axis :	X
Test Mode :	UNII-2A/ TX N20 Mode 5320MHz

**Vertical**

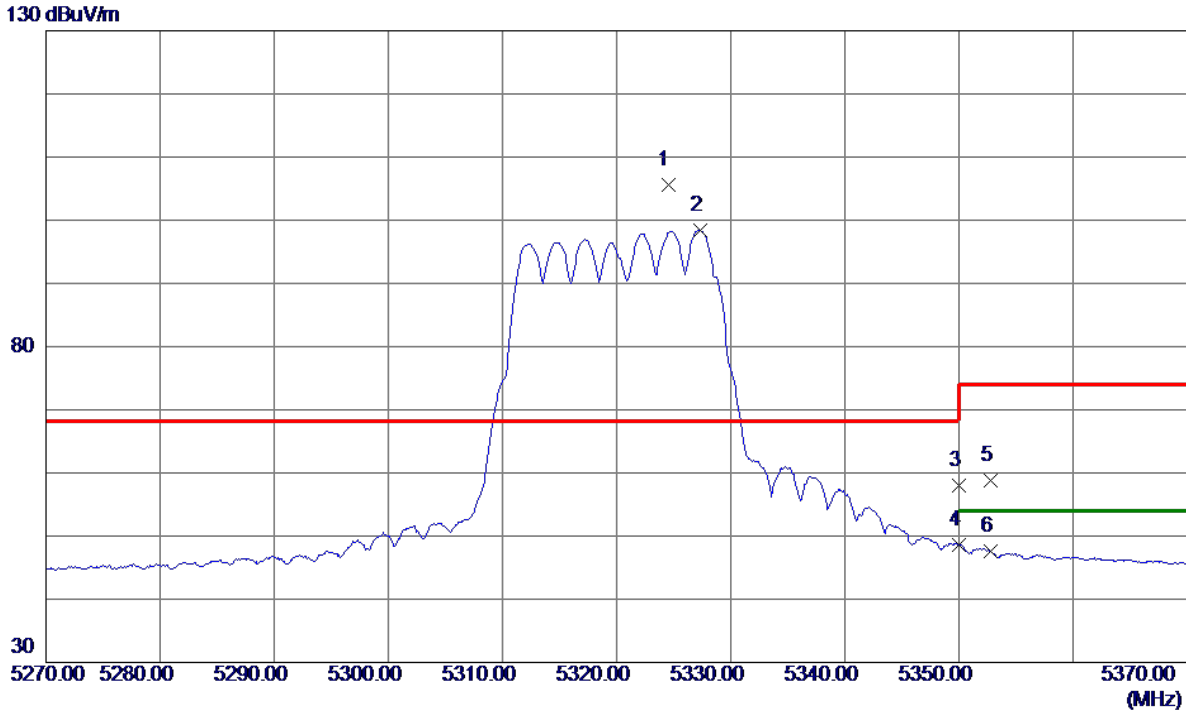

No.	Freq. MHz	Reading Level dBuV/m	Correct Factor dB	Measure ment dBuV/m	Limit dBuV/m	Margin dB	Detector	Comment
1 *	5324.5000	86.40	19.25	105.65	68.30	37.35	Peak	No Limit
2	5327.3000	79.15	19.26	98.41	999.00	-900.59	AVG	No Limit
3	5350.0000	38.65	19.40	58.05	74.00	-15.95	Peak	
4	5350.0000	29.24	19.40	48.64	999.00	-950.36	AVG	
5	5352.8000	39.31	19.42	58.73	74.00	-15.27	Peak	
6	5352.8000	28.16	19.42	47.58	54.00	-6.42	AVG	

Orthogonal Axis :	X
Test Mode :	UNII-2A/ TX N20 Mode 5320MHz

**Vertical**

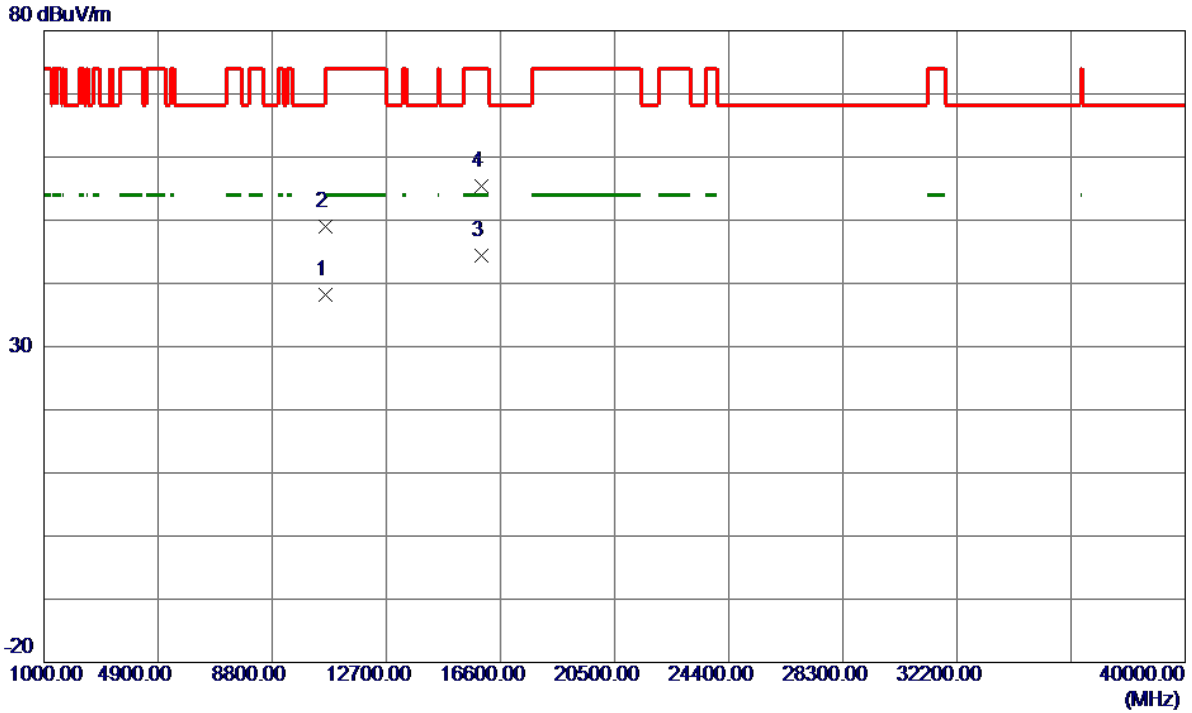

No.	Freq. MHz	Reading Level dBuV/m	Correct Factor dB	Measure ment dBuV/m	Limit dBuV/m	Margin dB	Detector	Comment
1	10636.5800	21.67	16.52	38.19	54.00	-15.81	AVG	
2	10638.9000	32.52	16.52	49.04	74.00	-24.96	Peak	
3 *	15960.3600	20.98	23.50	44.48	54.00	-9.52	AVG	
4	15963.1100	31.82	23.50	55.32	74.00	-18.68	Peak	

Orthogonal Axis :	X
Test Mode :	UNII-2A/ TX N20 Mode 5320MHz

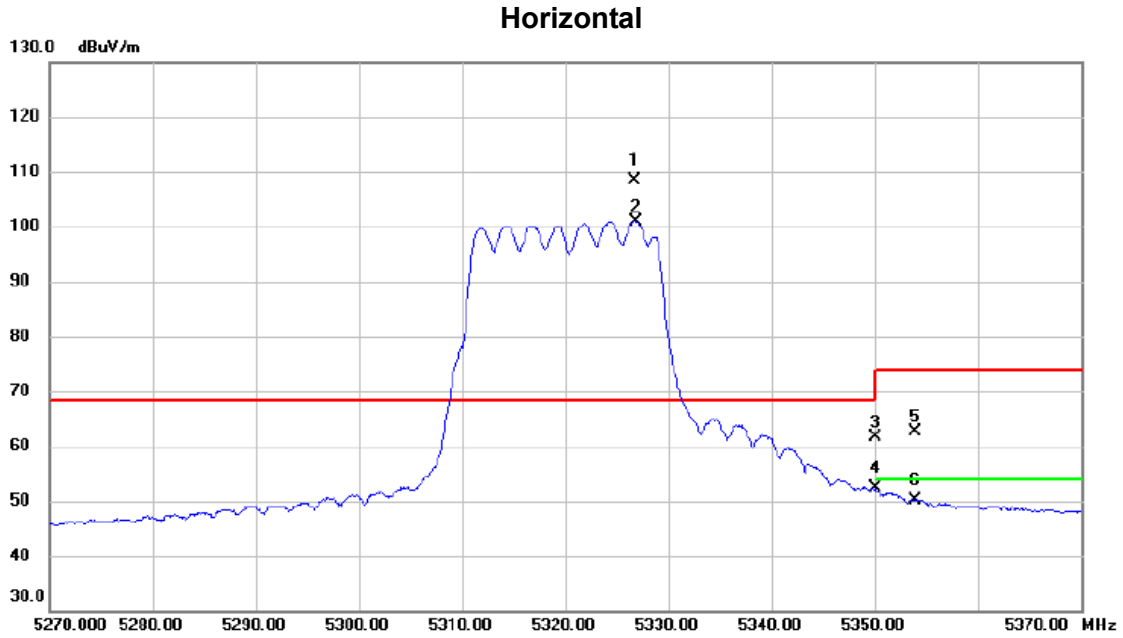

No.	Mk.	Freq. MHz	Reading Level dBuV	Correct Factor dB	Measure- ment dBuV/m	Limit dBuV/m	Margin dB	Detector	Comment
1	*	5326.700	89.02	19.26	108.28	68.30	39.98	AVG	No Limit
2	X	5326.900	81.64	19.26	100.90	68.30	32.60	peak	No Limit
3		5350.000	42.27	19.40	61.67	74.00	-12.33	peak	
4		5350.000	32.88	19.40	52.28	54.00	-1.72	AVG	
5		5353.900	43.14	19.43	62.57	74.00	-11.43	peak	
6		5353.900	30.82	19.43	50.25	54.00	-3.75	AVG	



Orthogonal Axis :	X
Test Mode :	UNII-2A/ TX N20 Mode 5320MHz

**Horizontal**

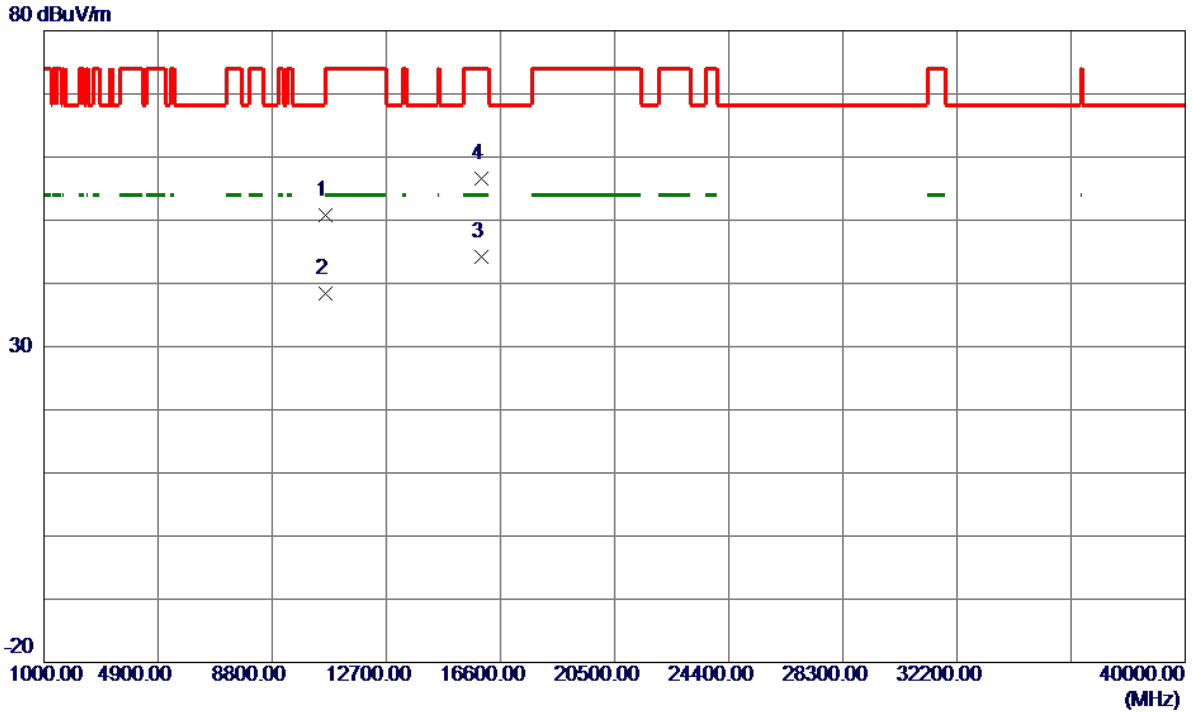

No.	Freq. MHz	Reading Level dBuV/m	Correct Factor dB	Measure ment dBuV/m	Limit dBuV/m	Margin dB	Detector	Comment
1	10636.5199	34.22	16.52	50.74	74.00	-23.26	Peak	
2	10637.4000	21.82	16.52	38.34	54.00	-15.66	AVG	
3 *	15956.3300	20.61	23.50	44.11	54.00	-9.89	AVG	
4	15962.6800	33.11	23.50	56.61	74.00	-17.39	Peak	

Orthogonal Axis :	X
Test Mode :	UNII-2A/ TX N40 Mode 5270MHz

**Vertical**

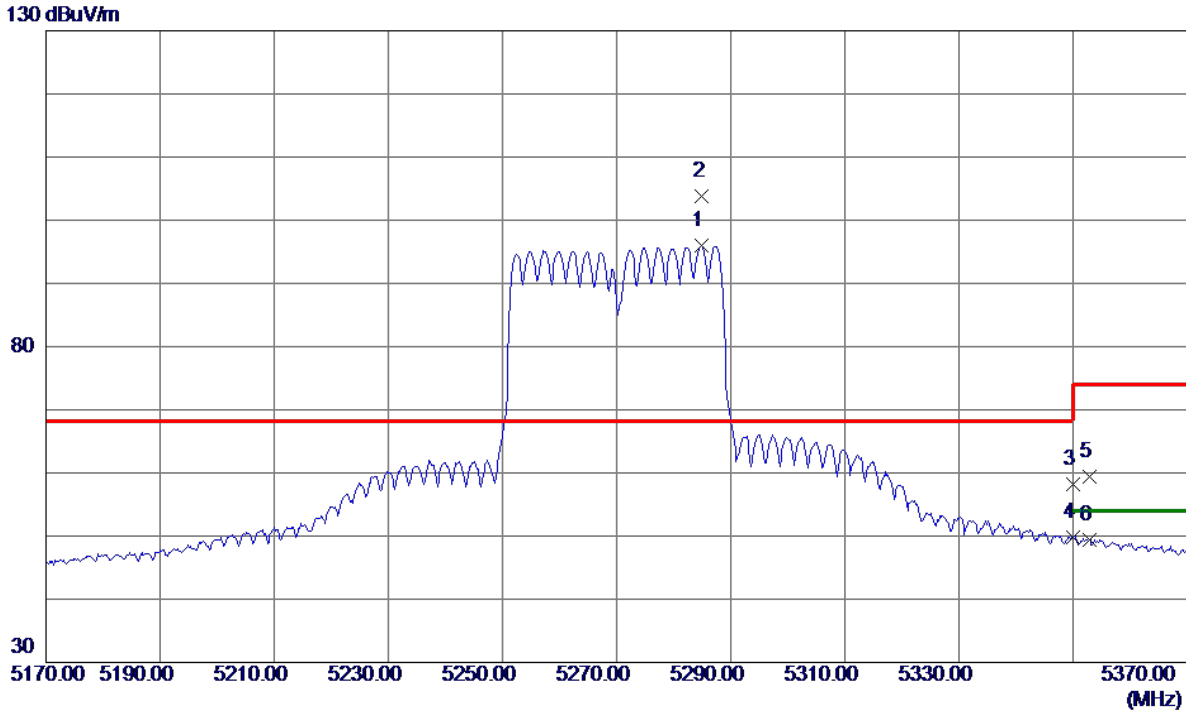

No.	Freq. MHz	Reading Level dBuV/m	Correct Factor dB	Measure ment dBuV/m	Limit dBuV/m	Margin dB	Detector	Comment
1	5284.8000	76.94	19.01	95.95	999.00	-903.05	AVG	No Limit
2 *	5285.0000	84.71	19.01	103.72	68.30	35.42	Peak	No Limit
3	5350.0000	38.75	19.40	58.15	74.00	-15.85	Peak	
4	5350.0000	30.43	19.40	49.83	999.00	-949.17	AVG	
5	5352.8000	39.94	19.42	59.36	74.00	-14.64	Peak	
6	5352.8000	30.04	19.42	49.46	54.00	-4.54	AVG	

Orthogonal Axis :	X
Test Mode :	UNII-2A/ TX N40 Mode 5270MHz

**Vertical**

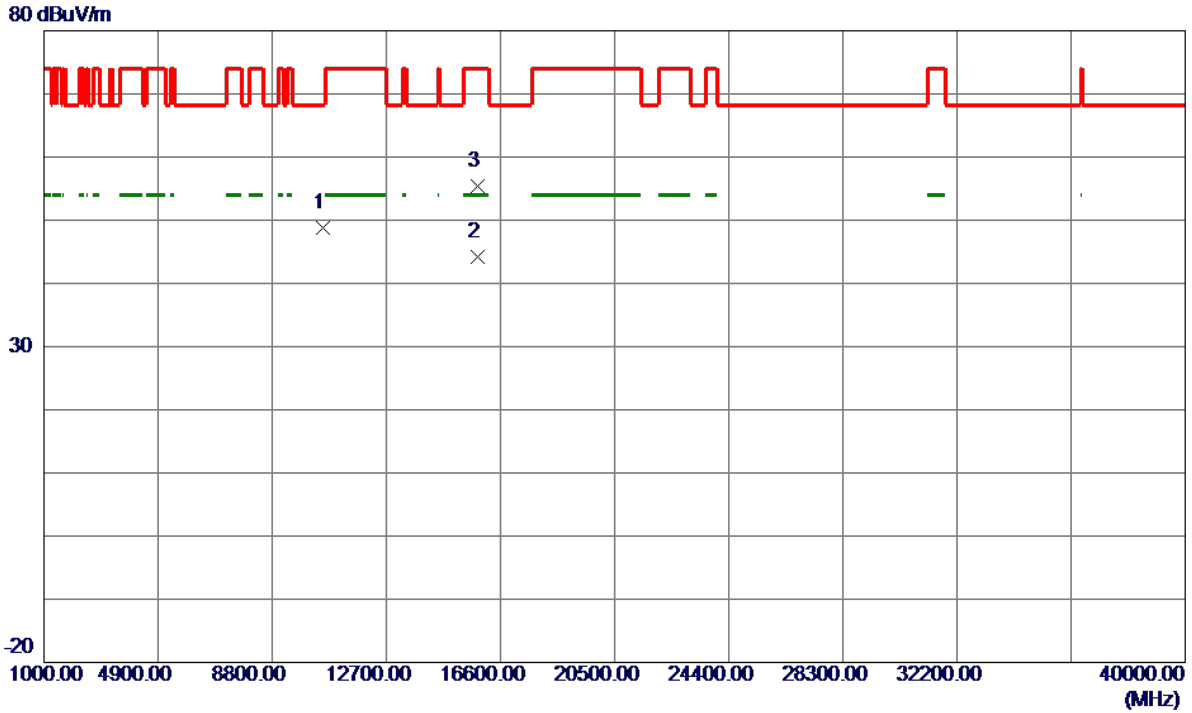

No.	Freq. MHz	Reading Level dBuV/m	Correct Factor dB	Measure ment dBuV/m	Limit dBuV/m	Margin dB	Detector	Comment
1	10543.2800	32.20	16.65	48.85	68.30	-19.45	Peak	
2 *	15806.7100	20.73	23.41	44.14	54.00	-9.86	AVG	
3	15813.0100	31.93	23.42	55.35	74.00	-18.65	Peak	

Orthogonal Axis :	X
Test Mode :	UNII-2A/ TX N40 Mode 5270MHz

**Horizontal**

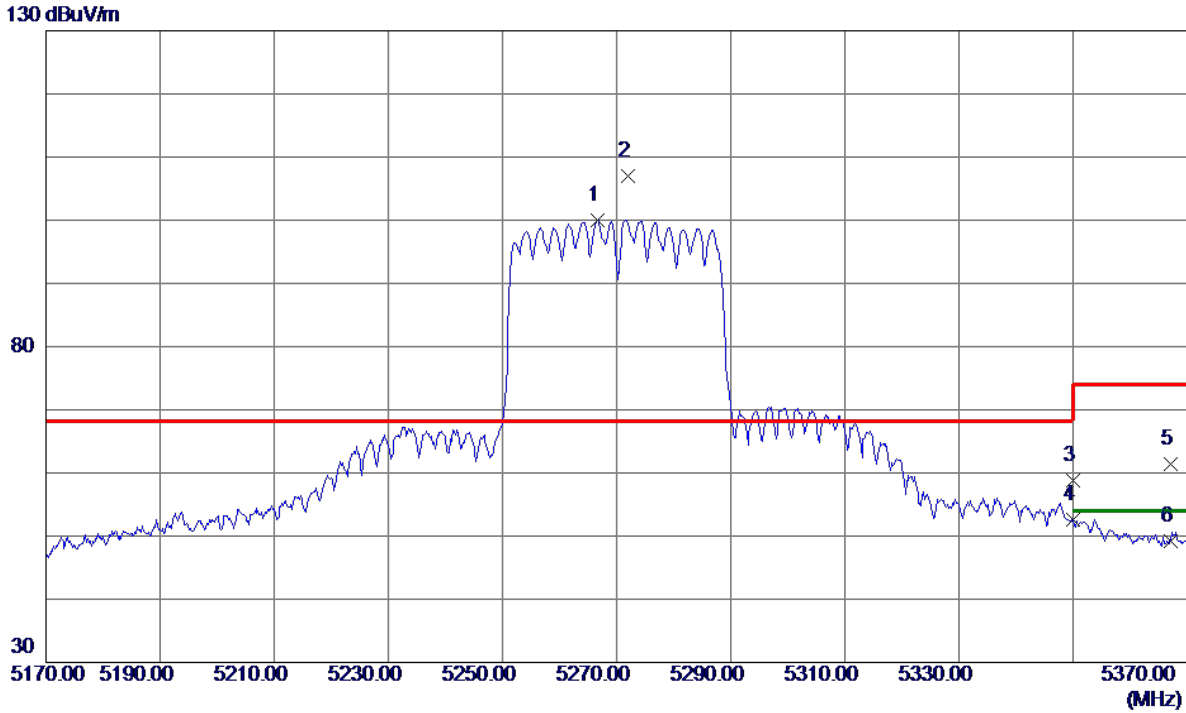

No.	Freq. MHz	Reading Level dBuV/m	Correct Factor dB	Measure ment dBuV/m	Limit dBuV/m	Margin dB	Detector	Comment
1	5266.6000	81.19	18.90	100.09	999.00	-898.91	AVG	No Limit
2 *	5272.0000	88.03	18.93	106.96	68.30	38.66	Peak	No Limit
3	5350.0000	39.48	19.40	58.88	74.00	-15.12	Peak	
4	5350.0000	33.20	19.40	52.60	999.00	-946.40	AVG	
5	5367.2000	41.82	19.50	61.32	74.00	-12.68	Peak	
6	5367.2000	29.67	19.50	49.17	54.00	-4.83	AVG	

Orthogonal Axis :	X
Test Mode :	UNII-2A/ TX N40 Mode 5270MHz

**Horizontal**

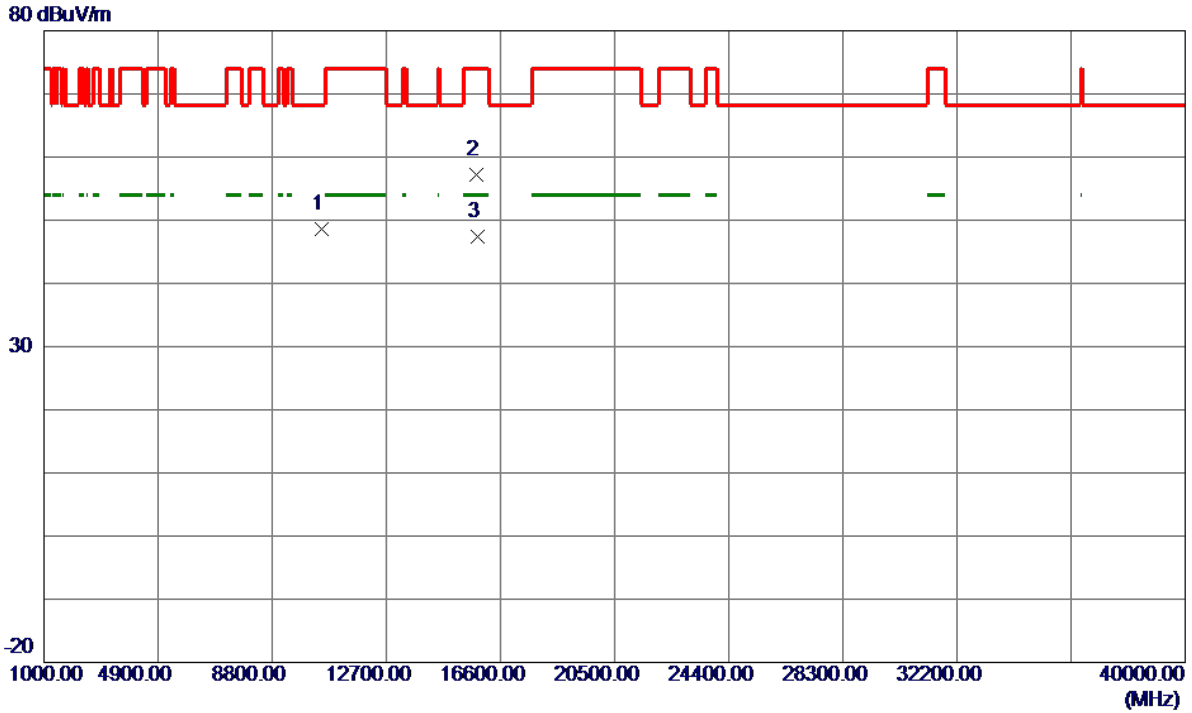

No.	Freq. MHz	Reading Level dBuV/m	Correct Factor dB	Measure ment dBuV/m	Limit dBuV/m	Margin dB	Detector	Comment
1	10494.4000	31.87	16.69	48.56	68.30	-19.74	Peak	
2	15796.2000	33.74	23.41	57.15	74.00	-16.85	Peak	
3 *	15807.6000	24.01	23.41	47.42	54.00	-6.58	AVG	

Orthogonal Axis :	X
Test Mode :	UNII-2A/ TX N40 Mode 5310MHz

**Vertical**

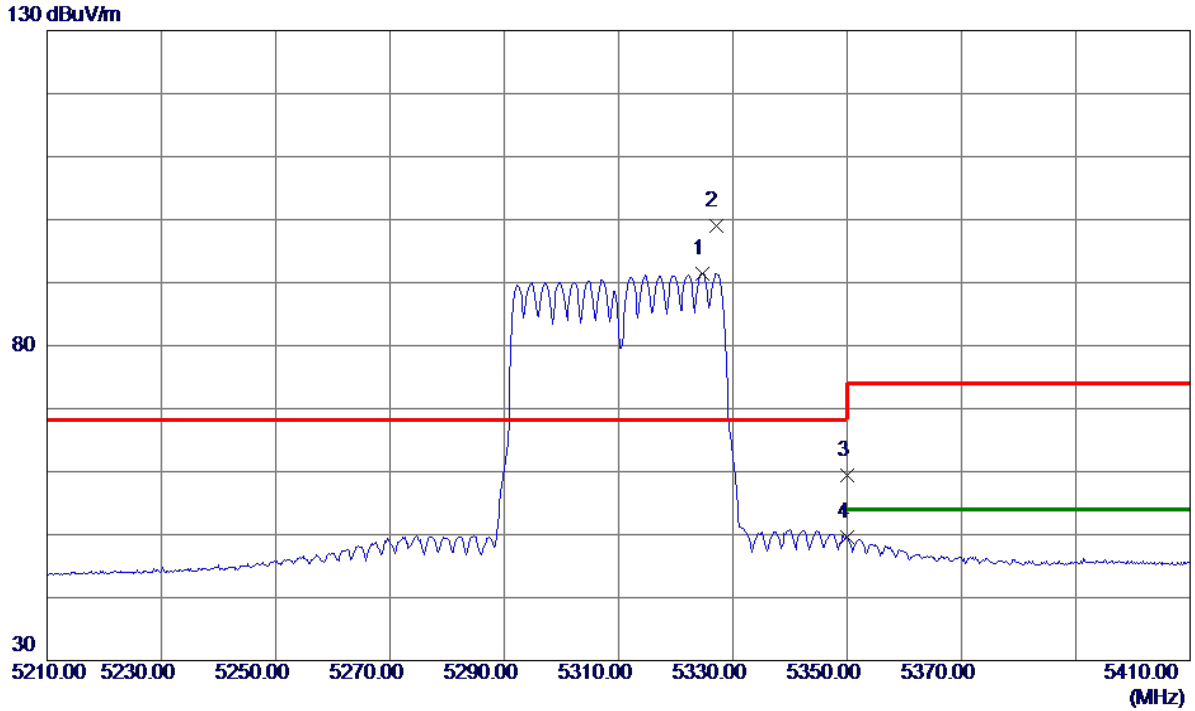

No.	Freq. MHz	Reading Level dBuV/m	Correct Factor dB	Measurement dBuV/m	Limit dBuV/m	Margin dB	Detector	Comment
1	5324.6000	72.17	19.25	91.42	999.00	-907.58	AVG	No Limit
2 *	5327.0000	79.66	19.26	98.92	68.30	30.62	Peak	No Limit
3	5350.0000	39.91	19.40	59.31	74.00	-14.69	Peak	
4	5350.0000	30.16	19.40	49.56	999.00	-949.44	AVG	

Orthogonal Axis :	X
Test Mode :	UNII-2A/ TX N40 Mode 5310MHz

**Vertical**

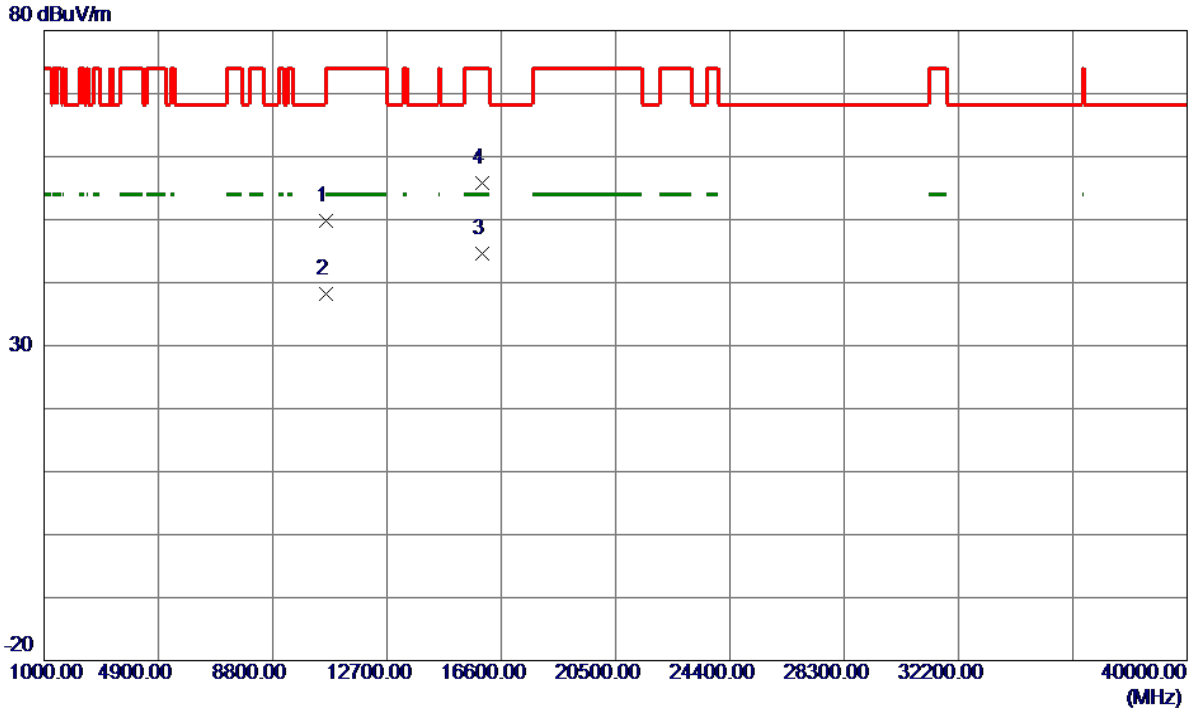

No.	Freq. MHz	Reading Level dBuV/m	Correct Factor dB	Measure ment dBuV/m	Limit dBuV/m	Margin dB	Detector	Comment
1	10617.3200	33.24	16.55	49.79	74.00	-24.21	Peak	
2	10623.2900	21.64	16.54	38.18	54.00	-15.82	AVG	
3 *	15929.3100	21.09	23.48	44.57	54.00	-9.43	AVG	
4	15931.9600	32.35	23.48	55.83	74.00	-18.17	Peak	

Orthogonal Axis :	X
Test Mode :	UNII-2A/ TX N40 Mode 5310MHz

**Horizontal**

130 dBuV/m

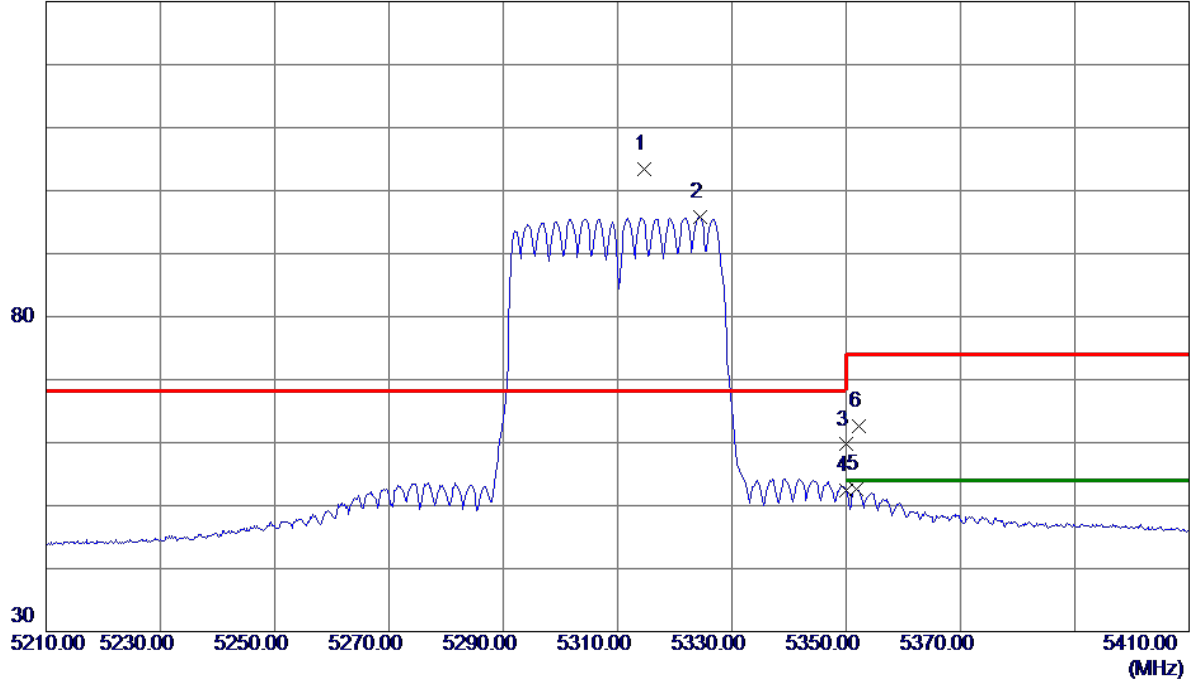

No.	Freq. MHz	Reading Level dBuV/m	Correct Factor dB	Measure ment dBuV/m	Limit dBuV/m	Margin dB	Detector	Comment
1 *	5314.6000	84.13	19.19	103.32	68.30	35.02	Peak	No Limit
2	5324.4000	76.50	19.25	95.75	999.00	-903.25	AVG	No Limit
3	5350.0000	40.30	19.40	59.70	74.00	-14.30	Peak	
4	5350.0000	33.04	19.40	52.44	999.00	-946.56	AVG	
5	5351.8000	33.16	19.41	52.57	54.00	-1.43	AVG	
6	5352.2000	43.16	19.41	62.57	74.00	-11.43	Peak	



Orthogonal Axis :	X
Test Mode :	UNII-2A/ TX N40 Mode 5310MHz

**Horizontal**

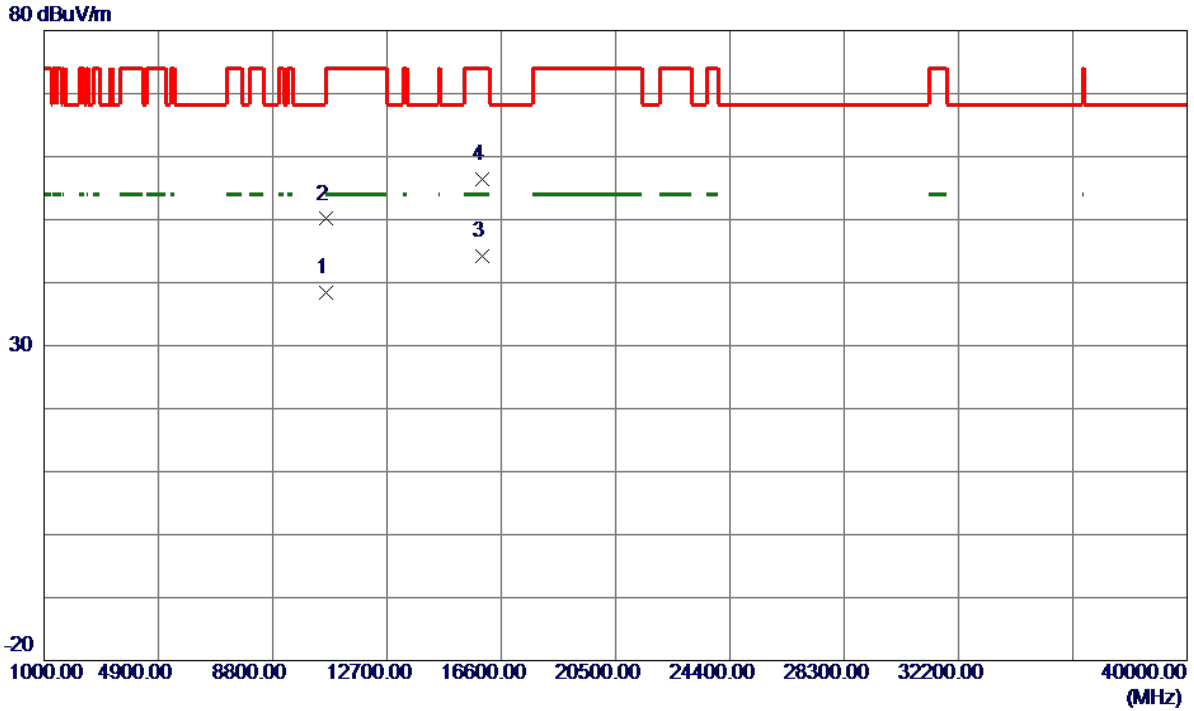

No.	Freq. MHz	Reading Level dBuV/m	Correct Factor dB	Measure ment dBuV/m	Limit dBuV/m	Margin dB	Detector	Comment
1	10616.6500	21.76	16.55	38.31	54.00	-15.69	AVG	
2	10622.7800	33.56	16.54	50.10	74.00	-23.90	Peak	
3 *	15928.4300	20.74	23.48	44.22	54.00	-9.78	AVG	
4	15933.1100	32.84	23.48	56.32	74.00	-17.68	Peak	

Orthogonal Axis :	X
Test Mode :	UNII-2C/ TX A Mode 5500MHz_ANT1

**Vertical**

130 dBuV/m

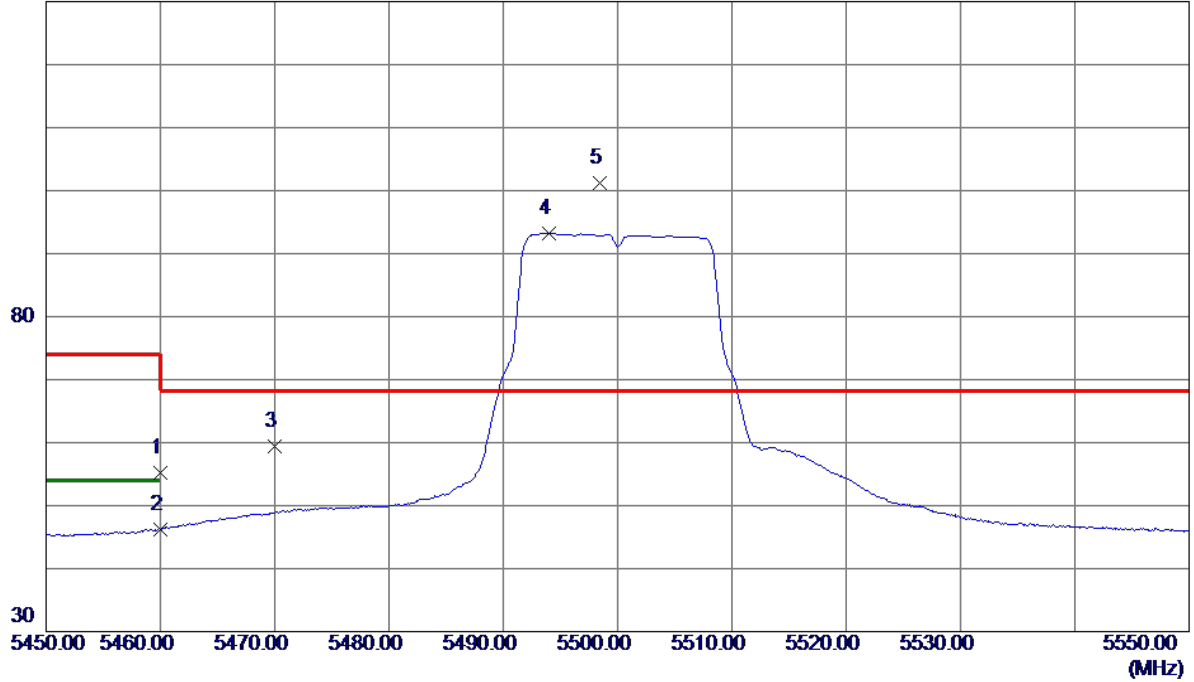

No.	Freq. MHz	Reading Level dBuV/m	Correct Factor dB	Measure ment dBuV/m	Limit dBuV/m	Margin dB	Detector	Comment
1	5460.0000	35.23	20.06	55.29	74.00	-18.71	Peak	
2	5460.0000	26.16	20.06	46.22	54.00	-7.78	AVG	
3	5470.0000	39.21	20.12	59.33	68.30	-8.97	Peak	
4	5494.0000	72.93	20.27	93.20	999.00	-905.80	AVG	No Limit
5 *	5498.4000	80.84	20.30	101.14	68.30	32.84	Peak	No Limit

Orthogonal Axis :	X
Test Mode :	UNII-2C/ TX A Mode 5500MHz_ANT1

**Vertical**

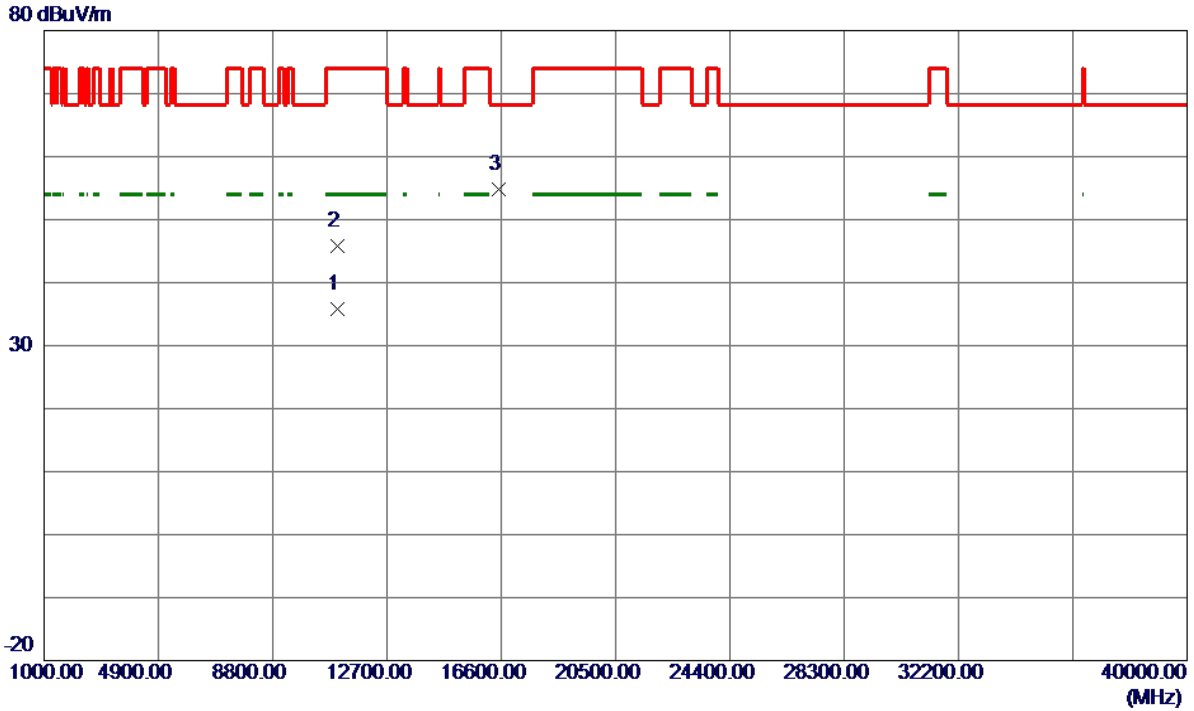

No.	Freq. MHz	Reading Level dBuV/m	Correct Factor dB	Measure ment dBuV/m	Limit dBuV/m	Margin dB	Detector	Comment
1	10995.6100	19.79	16.04	35.83	54.00	-18.17	AVG	
2	10998.2100	29.77	16.03	45.80	74.00	-28.20	Peak	
3 *	16495.1500	32.06	22.83	54.89	68.30	-13.41	Peak	

Orthogonal Axis :	X
Test Mode :	UNII-2C/ TX A Mode 5500MHz_ANT1

**Horizontal**

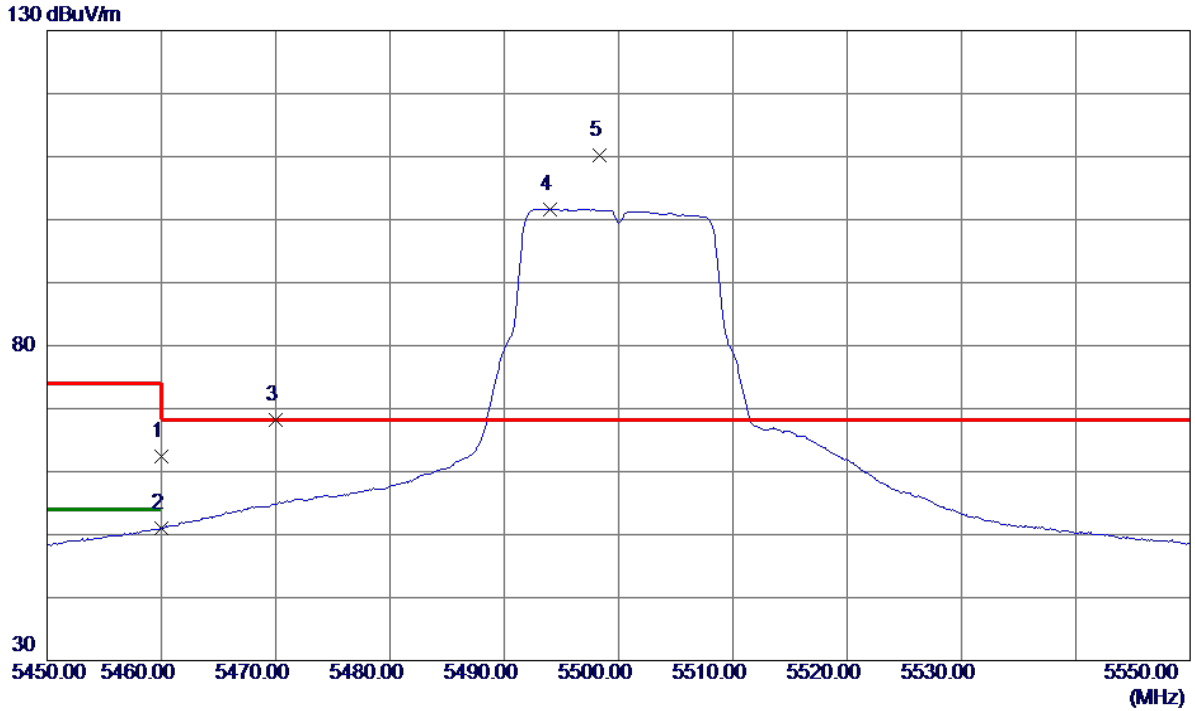

No.	Freq. MHz	Reading Level dBuV/m	Correct Factor dB	Measure ment dBuV/m	Limit dBuV/m	Margin dB	Detector	Comment
1	5460.0000	42.31	20.06	62.37	74.00	-11.63	Peak	
2	5460.0000	30.89	20.06	50.95	54.00	-3.05	AVG	
3	5470.0000	48.06	20.12	68.18	68.30	-0.12	Peak	
4	5494.0000	81.42	20.27	101.69	999.00	-897.31	AVG	No Limit
5 *	5498.3000	89.90	20.29	110.19	68.30	41.89	Peak	No Limit

Orthogonal Axis :	X
Test Mode :	UNII-2C/ TX A Mode 5500MHz_ANT1

**Horizontal**

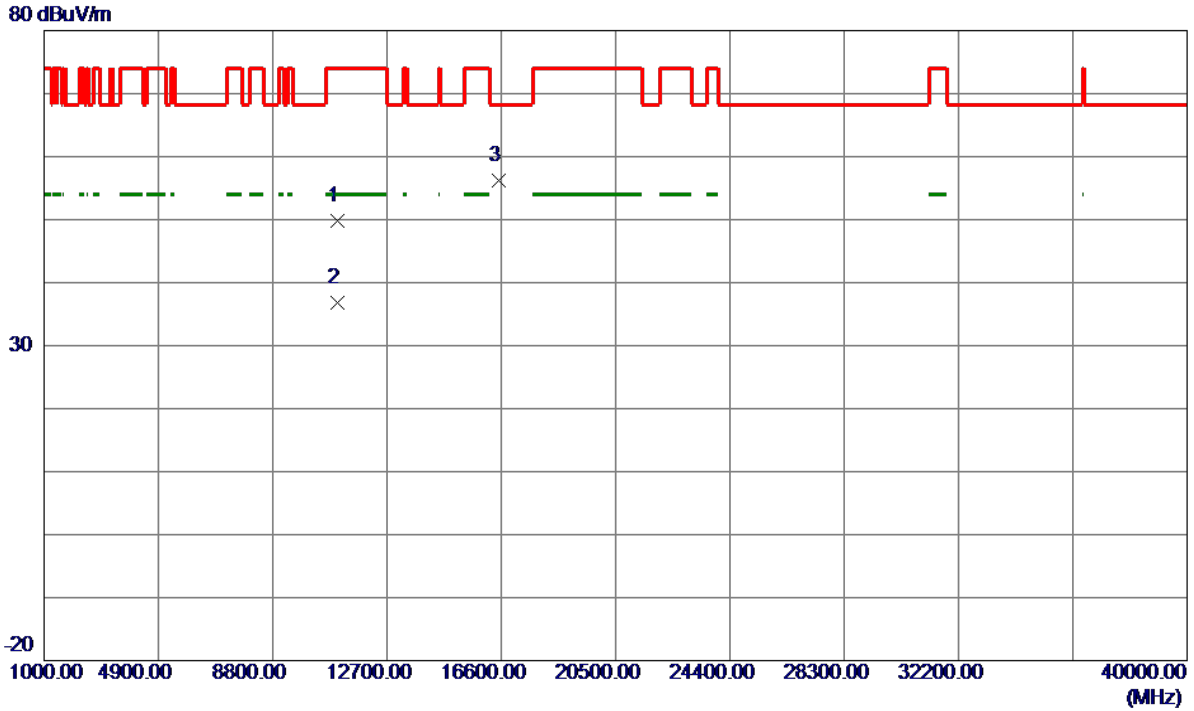

No.	Freq. MHz	Reading Level dBuV/m	Correct Factor dB	Measure ment dBuV/m	Limit dBuV/m	Margin dB	Detector	Comment
1	11002.1500	33.85	16.04	49.89	74.00	-24.11	Peak	
2	11004.8400	20.82	16.05	36.87	54.00	-17.13	AVG	
3 *	16495.5700	33.41	22.83	56.24	68.30	-12.06	Peak	

Orthogonal Axis :	X
Test Mode :	UNII-2C/ TX A Mode 5500MHz_ANT2

**Vertical**

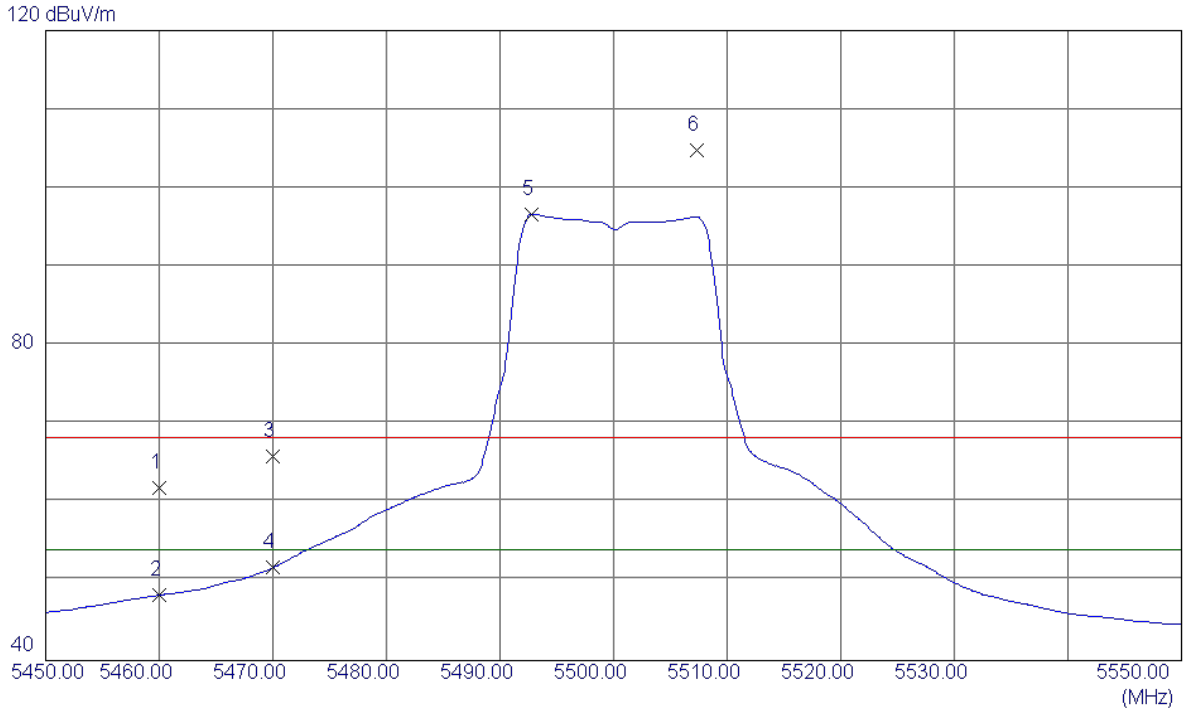

No.	Freq. MHz	Reading Level dBuV/m	Correct Factor dB	Measure ment dBuV/m	Limit dBuV/m	Margin dB	Detector	Comment
1	5460.0000	20.49	41.43	61.92	68.30	-6.38	Peak	
2	5460.0000	6.87	41.43	48.30	54.00	-5.70	AVG	
3	5470.0000	24.48	41.46	65.94	68.30	-2.36	Peak	
4	5470.0000	10.34	41.46	51.80	54.00	-2.20	AVG	
5 *	5492.8000	55.15	41.54	96.69	54.00	42.69	AVG	NO LIMIT
6	5507.3000	63.25	41.58	104.83	68.30	36.53	Peak	NO LIMIT

Remark: This test data is from original report BTL-FCCP-4-1602C038.

Orthogonal Axis :	X
Test Mode :	UNII-2C/ TX A Mode 5500MHz_ANT2

**Vertical**

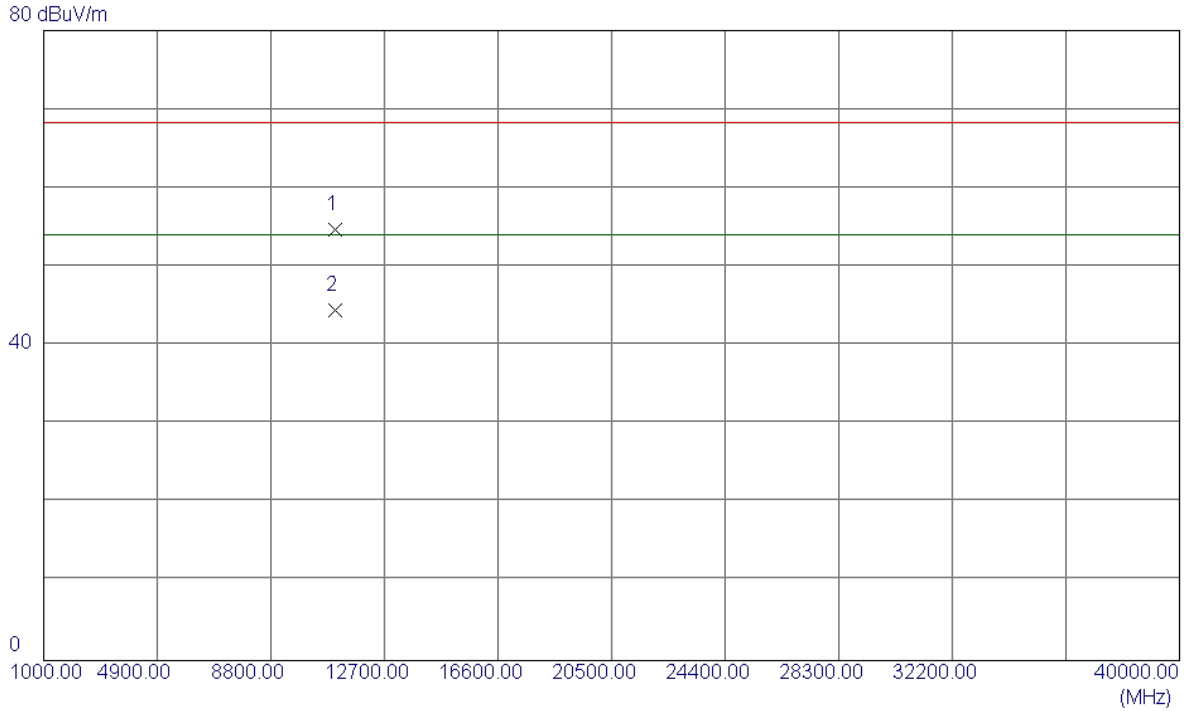

No.	Freq. MHz	Reading Level dBuV/m	Correct Factor dB	Measure ment dBuV/m	Limit dBuV/m	Margin dB	Detector	Comment
1	11000.5599	38.67	16.09	54.76	68.30	-13.54	Peak	
2 *	11001.7800	28.44	16.09	44.53	54.00	-9.47	AVG	

Remark: This test data is from original report BTL-FCCP-4-1602C038.

Orthogonal Axis :	X
Test Mode :	UNII-2C/ TX A Mode 5500MHz_ANT2

### Horizontal

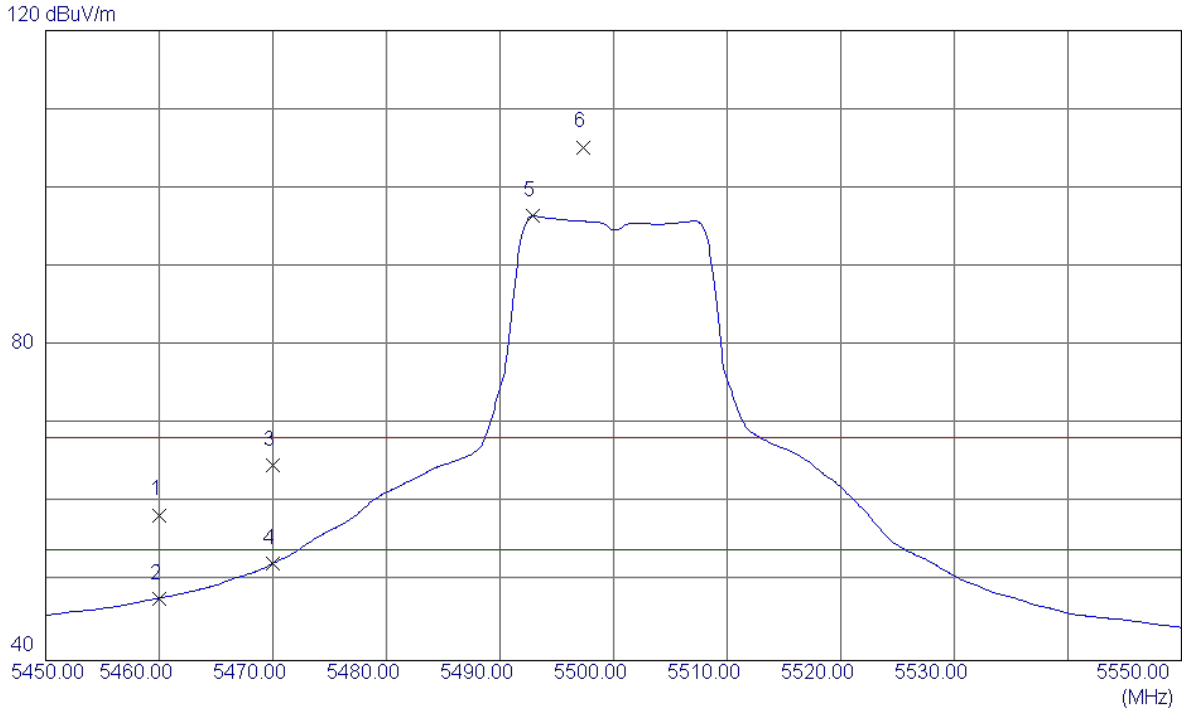

No.	Freq. MHz	Reading Level dBuV/m	Correct Factor dB	Measure ment dBuV/m	Limit dBuV/m	Margin dB	Detector	Comment
1	5460.0000	17.05	41.43	58.48	68.30	-9.82	Peak	
2	5460.0000	6.49	41.43	47.92	54.00	-6.08	AVG	
3	5470.0000	23.29	41.46	64.75	68.30	-3.55	Peak	
4	5470.0000	10.87	41.46	52.33	54.00	-1.67	AVG	
5 *	5492.9000	54.90	41.54	96.44	54.00	42.44	AVG	NO LIMIT
6	5497.3000	63.65	41.55	105.20	68.30	36.90	Peak	NO LIMIT

Remark: This test data is from original report BTL-FCCP-4-1602C038.



Orthogonal Axis :	X
Test Mode :	UNII-2C/ TX A Mode 5500MHz_ANT2

**Horizontal**

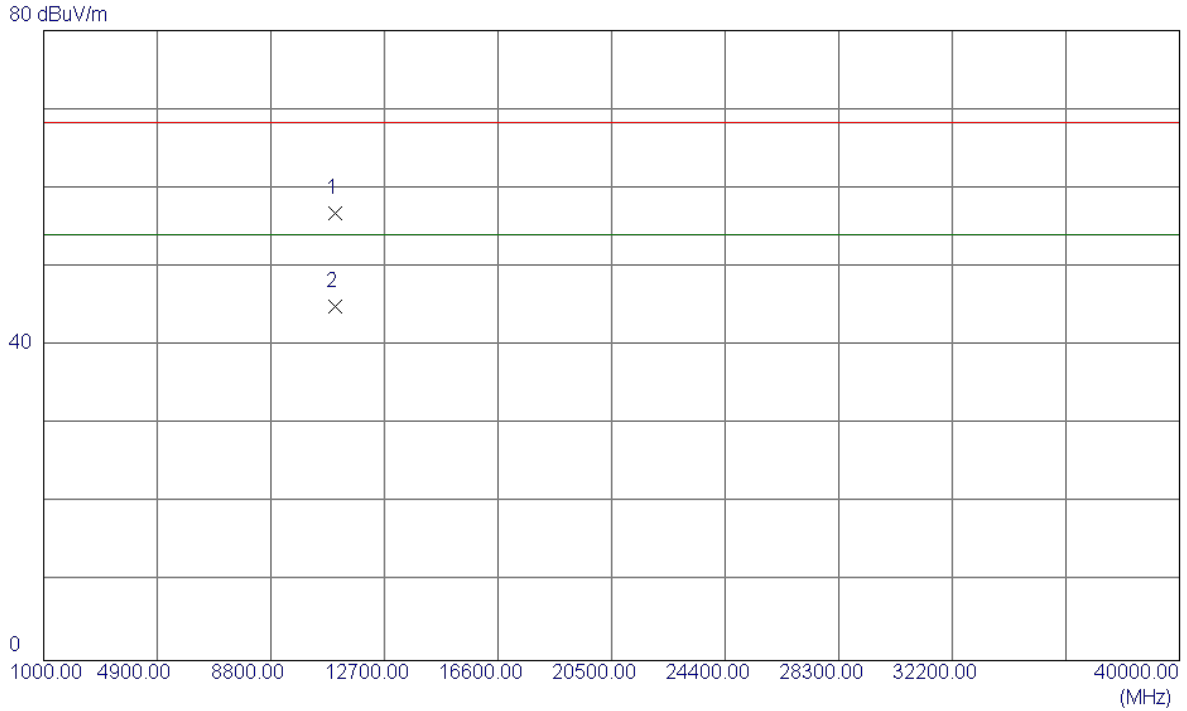

No.	Freq. MHz	Reading Level dBuV/m	Correct Factor dB	Measure ment dBuV/m	Limit dBuV/m	Margin dB	Detector	Comment
1	11001.2400	40.67	16.09	56.76	68.30	-11.54	Peak	
2 *	11001.4800	28.88	16.09	44.97	54.00	-9.03	AVG	

Remark: This test data is from original report BTL-FCCP-4-1602C038.

Orthogonal Axis :	X
Test Mode :	UNII-2C/ TX A Mode 5580MHz_ANT1

**Vertical**

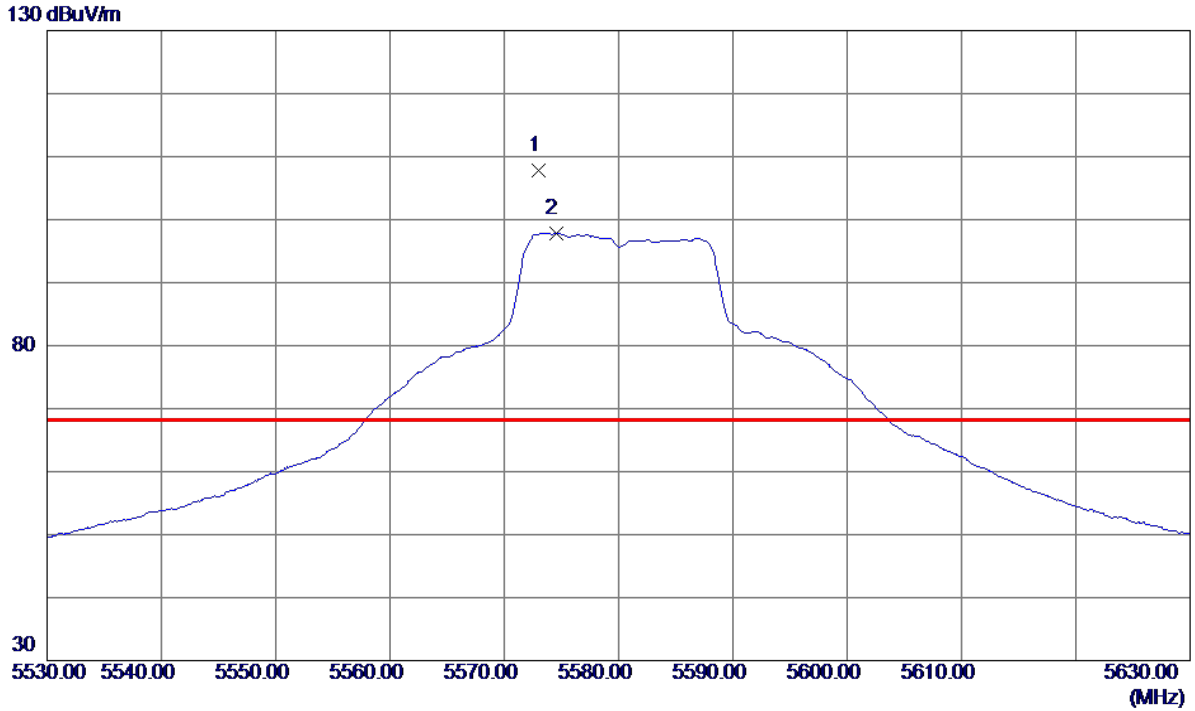

No.	Freq. MHz	Reading Level dBuV/m	Correct Factor dB	Measure ment dBuV/m	Limit dBuV/m	Margin dB	Detector	Comment
1 *	5573.0000	87.24	20.59	107.83	68.30	39.53	Peak	No Limit
2	5574.5000	77.21	20.60	97.81	999.00	-901.19	AVG	No Limit

Orthogonal Axis :	X
Test Mode :	UNII-2C/ TX A Mode 5580MHz_ANT1

**Vertical**

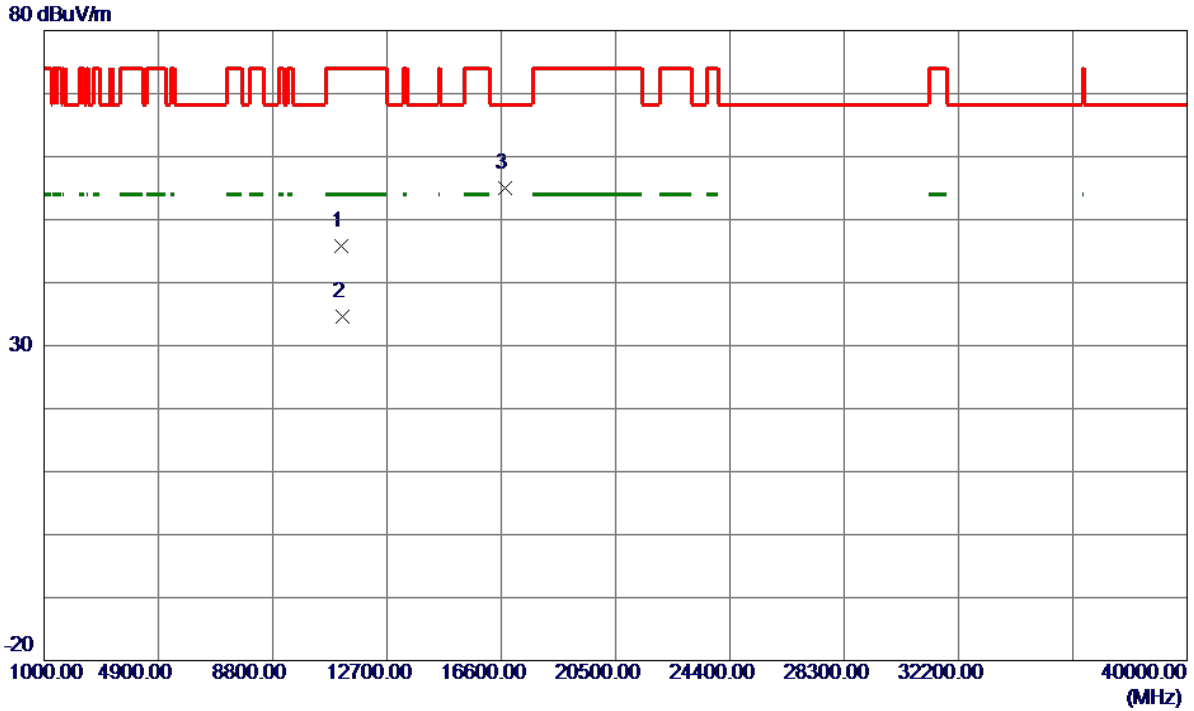

No.	Freq. MHz	Reading Level dBuV/m	Correct Factor dB	Measure ment dBuV/m	Limit dBuV/m	Margin dB	Detector	Comment
1	11160.6500	29.14	16.59	45.73	74.00	-28.27	Peak	
2	11163.0800	18.03	16.60	34.63	54.00	-19.37	AVG	
3 *	16737.4600	32.21	22.84	55.05	68.30	-13.25	Peak	