



FCC PART 15C TEST REPORT FOR CERTIFICATION  
On Behalf of

NVIDIA Corporation

Complex Set-Top Box

Model Number: P2571

FCC ID: VOB-P2571

Prepared for : NVIDIA Corporation  
2701 San Tomas Expressway, Santa Clara, CA, 95050, USA

Prepared By : Audix Technology (Shenzhen) Co., Ltd.  
No. 6, Ke Feng Rd., 52 Block,  
Shenzhen Science & Industrial Park,  
Nantou, Shenzhen, Guangdong, China

Tel: (0755) 26639496

Report Number : ACS-F15002  
Date of Test : Dec.16, 2014~Jan.02, 2015  
Date of Report : Feb.09, 2015

## TABLE OF CONTENTS

Description	Page
<b>1. SUMMARY OF STANDARDS AND RESULTS .....</b>	<b>1-1</b>
1.1. Description of Standards and Results .....	1-1
<b>2. GENERAL INFORMATION .....</b>	<b>2-1</b>
2.1. Description of Device (EUT) .....	2-1
2.2. Test Information .....	2-2
2.3. Tested Supporting System Details .....	2-3
2.4. Block Diagram of Test Setup .....	2-3
2.5. Test Facility .....	2-4
2.6. Measurement Uncertainty (95% confidence levels, k=2).....	2-4
<b>3. POWER LINE CONDUCTED EMISSION TEST.....</b>	<b>3-1</b>
3.1. Test Equipments .....	3-1
3.2. Block Diagram of Test Setup .....	3-1
3.3. Power Line Conducted Emission Test Limits .....	3-1
3.4. Configuration of EUT on Test.....	3-2
3.5. Operating Condition of EUT .....	3-2
3.6. Test Procedure .....	3-2
3.7. Power Line Conducted Emission Test Results .....	3-2
<b>4. RADIATED EMISSION TEST .....</b>	<b>4-1</b>
4.1. Test Equipment.....	4-1
4.2. Block Diagram of Test Setup .....	4-2
4.3. Radiated Emission Limit .....	4-3
4.4. EUT Configuration on Test.....	4-3
4.5. Operating Condition of EUT .....	4-3
4.6. Test Procedure .....	4-4
4.7. Radiated Emission Test Results .....	4-4
<b>5. CONDUCTED SPURIOUS EMISSIONS .....</b>	<b>5-1</b>
5.1. Test Equipment.....	5-1
5.2. Limit .....	5-1
5.3. Test Procedure .....	5-1
5.4. Test result .....	5-1
<b>6. BAND EDGE COMPLIANCE TEST .....</b>	<b>6-1</b>
6.1. Test Equipment.....	6-1
6.2. Limit .....	6-1
6.3. Test Produce .....	6-1
6.4. Test Results .....	6-1
<b>7. 6dB Bandwidth Test .....</b>	<b>7-1</b>
7.1. Test Equipment.....	7-1
7.2. Limit .....	7-1
7.3. Test Procedure .....	7-1
7.4. Test Results .....	7-1
<b>8. OUTPUT POWER TEST .....</b>	<b>8-1</b>
8.1. Test Equipment.....	8-1
8.2. Limit (FCC Part 15C 15.247 b(3)) .....	8-1
8.3. Test Procedure .....	8-1
8.4. Test Results .....	8-2
<b>9. POWER SPECTRAL DENSITY TEST .....</b>	<b>9-1</b>
9.1. Test Equipment.....	9-1

9.2.	Limit .....	9-1
9.3.	Test Procedure .....	9-1
9.4.	Test Results .....	9-2
<b>10.</b>	<b>MPE ESTIMATION .....</b>	<b>10-1</b>
10.1.	Limit for General Population/ Uncontrolled Exposures .....	10-1
10.2.	Estimation Result.....	10-2
<b>11.</b>	<b>ANTENNA REQUIREMENT .....</b>	<b>11-1</b>
11.1.	STANDARD APPLICABLE .....	11-1
11.2.	ANTENNA CONNECTED CONSTRUCTION .....	11-1
<b>12.</b>	<b>DEVIATION TO TEST SPECIFICATIONS .....</b>	<b>12-1</b>
<b>13.</b>	<b>PHOTOGRAPH OF TEST.....</b>	<b>13-1</b>
13.1.	Photos of Power Line Conducted Emission Test .....	13-1
13.2.	Photos of Radiated Emission Test .....	13-2
<b>14.</b>	<b>PHOTOGRAPH OF EUT.....</b>	<b>14-1</b>

## TEST REPORT CERTIFICATION

Applicant : NVIDIA Corporation  
Manufacturer : NVIDIA Corporation  
EUT Description : Complex Set-Top Box  
FCC ID : VOB-P2571  
(A) MODEL NO. : P2571  
(B) SERIAL NO. : N/A  
(C) TEST VOLTAGE : DC 19V From Adapter Input AC 120V/60Hz

Tested for comply with:  
FCC Rules and Regulations Part 15 Subpart C: 2014

Test procedure used:  
ANSI C63.10: 2009  
KDB558074 D01 v03r02

The device described above is tested by AUDIX TECHNOLOGY (SHENZHEN) CO., LTD. to confirm comply with all the FCC Part 15 Subpart C requirements. The test results are contained in this test report and AUDIX TECHNOLOGY (SHENZHEN) CO., LTD. is assumed full responsibility for the accuracy and completeness of these tests. Also, this report shows that the Equipment Under Test (EUT) is to be technically compliant with the FCC and IC requirements. This report contains data that are not covered by the NVLAP accreditation.

This Report is made under FCC Part 2.1075. No modifications were required during testing to bring this product into compliance.

This report applies to above tested sample only. This report shall not be reproduced in part without written approval of AUDIX TECHNOLOGY (SHENZHEN) CO., LTD.

The report must not be used by the client to claim product certification, approval, or endorsement by NVLAP, NIST, or any agency of the federal government.

Date of Test : Dec.16, 2014~Jan.02, 2015 Report of date: Feb.09, 2015

Prepared by : Kayli He Reviewed by : [Signature]  
Kayli He / Assistant Sunny Lu / Assistant Manager



Approved & Authorized Signer : David Jin  
David Jin / Manager

## 1. SUMMARY OF STANDARDS AND RESULTS

### 1.1. Description of Standards and Results

The EUT have been tested according to the applicable standards as referenced below.

EMISSION		
Description of Test Item	Standard	Results
Power Line Conducted Emission	FCC Part 15: 15.207	PASS
Radiated Emission	FCC Part 15: 15.209	PASS
Band Edge Compliance	FCC Part 15: 15.247	PASS
Conducted spurious emissions	FCC Part 15: 15.247	PASS
6dB Bandwidth	FCC Part 15: 15.247	PASS
Peak Output Power	FCC Part 15: 15.247	PASS
Power Spectral Density	FCC Part 15: 15.247	PASS
Antenna requirement	FCC Part 15: 15.203	PASS

## 2. GENERAL INFORMATION

### 2.1. Description of Device (EUT)

Product Name	: Complex Set-Top Box
Model Number	: P2571
FCC ID	: VOB-P2571
Radio	: IEEE802.11 a/b/g/n/ac; Bluetooth V3.0+EDR; Bluetooth V4.1(LE)
Operation Frequency	: IEEE 802.11a: 5180MHz—5240MHz 5745MHz—5825MHz IEEE 802.11ac VHT20: 5180MHz—5240MHz, 5745MHz—5825MHz IEEE 802.11ac VHT40: 5190MHz—5230MHz, 5755MHz—5795MHz IEEE 802.11ac VHT80: 5210MHz, 5775MHz IEEE 802.11b: 2412MHz—2462MHz IEEE 802.11g: 2412MHz—2462MHz IEEE802.11nHT20: 2412MHz—2462MHz;5180MHz—5240MHz, 5745MHz—5825MHz IEEE802.11nHT40: 2422MHz—2452MHz5190MHz—5230MHz, 5755MHz—5795MHz Bluetooth : 2402-2480MHz
Modulation Technology	: IEEE 802.11b: DSSS(CCK,DQPSK,DBPSK) IEEE 802.11a/g: OFDM(64QAM, 16QAM, QPSK, BPSK) IEEE 802.11ac VHT20, VHT40, VHT80: OFDM(16QAM, 64QAM, 256QAM, QPSK, BPSK) IEEE 802.11n HT20, HT40: OFDM (64QAM, 16QAM,QPSK,BPSK) Bluetooth V3.0+EDR: GFSK, $\pi/4$ DQPSK,8-DPSK Bluetooth V4.1(LE):GFSK
Antenna Assembly Gain	: Antenna Type: Dipole Bluetooth: 3.34dBi WIFI 2.4GHz:ANT 1: 4.13dBi; ANT 2: 3.34dBi U-NII 5180-5240MHz Band:ANT 1: 6.09dBi; ANT 2: 6.93dBi U-NII 5745-5825MHz Band:ANT 1: 6.15dBi; ANT 2: 6.99dBi

Applicant : NVIDIA Corporation  
2701 San Tomas Expressway, Santa Clara, CA,95050,USA

Manufacturer : NVIDIA Corporation  
2701 San Tomas Expressway, Santa Clara, CA,95050,USA

Power Adapter : Manufacture :FSP GROUP INC.  
Model Name: SPA040A19W2  
Data Cable:Unshielded,Undetachable,1.9m

USB Cable : Shielded, Detachable, 1.0m

HDMI Cable : Shieled,Detachable,1.8m

Date of Test : Dec.16, 2014~Jan.02, 2015

Date of Receipt : Dec.10 ,2014

## 2.2. Test Information

A special test software was used to control EUT work in Continuous TX mode(nearly 100% duty cycle), and select test channel, wireless mode and data rate.

Tested mode, channel, and data rate information			
Mode	data rate (Mbps)(see Note)	Channel	Frequency (MHz)
IEEE 802.11b	1	Low :CH1	2412
	1	Middle: CH6	2437
	1	High: CH11	2462
IEEE 802.11g	6	Low :CH1	2412
	6	Middle: CH6	2437
	6	High: CH11	2462
IEEE 802.11n HT20	MCS0	Low :CH1	2412
	MCS0	Middle: CH6	2437
	MCS0	High: CH11	2462
IEEE 802.11n HT40	MCS0	Low :CH3	2422
	MCS0	Middle: CH6	2437
	MCS0	High: CH9	2452

Note: 1. According exploratory test, EUT will have maximum output power in those data rate, so those data rate were used for all test.  
2. This is 2T2R device, test comply with the Requirement of KDB662911.  
3. IEEE802.11b/g use SISO and 11n use MIMO mode during the test.

### 2.3. Tested Supporting System Details

No.	Description	ACS No.	Manufacturer	Model	Serial Number	Approved type
1.	Notebook	N/A	ACER	ZOW	N/A	<input checked="" type="checkbox"/> FCC DoC <input checked="" type="checkbox"/> BSMI ID:R41108
		Power Cord: Unshielded, Detachable, 1.8m Power Adapter: Manufacturer: Lite-On, M/N: PA-1900-32 Data Cable: Shielded, Undetectable, 4.0m(Bond one ferrite core)				
2.	Monitor	ACS-EMC-LM10R	DELL	U3011t	CN-OPH5NY-7 4445-097-505L	<input checked="" type="checkbox"/> FCC DoC <input checked="" type="checkbox"/> BSMI ID:R43004
		Power Cord: Unshielded, Detachable, 1.8m				
3.	USB Disk*2	Kingston,4G mini Memory				
4.	SD Card	Kingston,1G Memory				
5.	LAN Cable	Shielded, Detachable, 2.0m				

### 2.4. Block Diagram of Test Setup

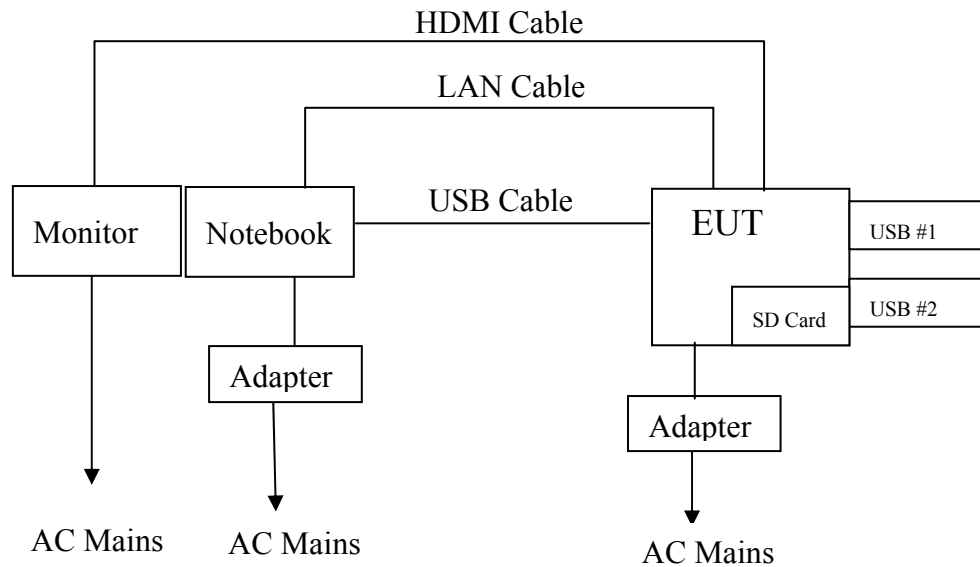

( EUT: Complex Set-Top Box)



## 2.5. Test Facility

### Site Description

Name of Firm	:	Audix Technology (Shenzhen) Co., Ltd. No. 6, Ke Feng Rd., 52 Block, Shenzhen Science & Industrial Park, Nantou, Shenzhen, Guangdong, China
3m Anechoic Chamber	:	Certificated by FCC, USA Registration Number: 90454 Valid Date: Feb.22, 2015
3m & 10m Anechoic Chamber	:	Certificated by FCC, USA Registration Number: 794232 Valid Date: Oct.31, 2015
EMC Lab.	:	Certificated by Industry Canada Registration Number: IC 5183A-1 Valid Date: May.14, 2017
	:	Certificated by DAkkS, Germany Registration No: D-PL-12151-01-00 Valid Date: Dec.15, 2016
	:	Accredited by NVLAP, USA NVLAP Code: 200372-0 Valid Date: Mar.31, 2015

## 2.6. Measurement Uncertainty (95% confidence levels, k=2)

Test Item	Uncertainty
Uncertainty for Conduction emission test in No. 1 Conduction	3.10dB (150KHz to 30MHz)
Uncertainty for Radiation Emission test in 3m chamber	3.22 dB(30~200MHz, Polarize: H)
	3.23 dB(30~200MHz, Polarize: V)
	3.49 dB(200M~1GHz, Polarize: H)
	3.39 dB(200M~1GHz, Polarize: V)
Uncertainty for Radiation Emission test in 3m chamber (1GHz-18GHz)	4.97 dB (1~6GHz, Distance: 3m)
	4.99 dB (6~18GHz, Distance: 3m)
Uncertainty for Radiated Spurious Emission test in RF chamber	3.57 dB
Uncertainty for Conduction Spurious emission test	2.00 dB
Uncertainty for Output power test	0.73 dB
Uncertainty for Bandwidth test	83 kHz
Uncertainty for DC power test	0.038 %
Uncertainty for test site temperature and humidity	0.6°C
	3%

### 3. POWER LINE CONDUCTED EMISSION TEST

#### 3.1. Test Equipments

Item	Equipment	Manufacturer	Model No.	Serial No.	Last Cal.	Cal. Interval
1.	1# Shielding Room	AUDIX	N/A	N/A	Apr.17,14	1 Year
2.	Test Receiver	Rohde & Schwarz	ESHS10	838693/001	Oct.29, 14	1 Year
3.	L.I.S.N.#1	Rohde & Schwarz	ESH2-Z5	100429	Jan.22, 14	1 Year
4.	L.I.S.N.#3	Kyoritsu	KNW-242C	8-1920-1	Apr. 28,14	1 Year
5.	Terminator	Hubersuhner	50Ω	No. 1	Apr. 28,14	1 Year
6.	Terminator	Hubersuhner	50Ω	No. 2	Apr. 28,14	1 Year
7.	RF Cable	Hubersuhner	RG58	0100.6954.20#	Jan.22, 14	1 Year
8.	Coaxial Switch	Anritsu	MP59B	6200298346	Apr. 28,14	1 Year
9.	Pulse Limiter	Rohde & Schwarz	ESH3-Z2	101838	Jan.22, 14	1 Year

#### 3.2. Block Diagram of Test Setup

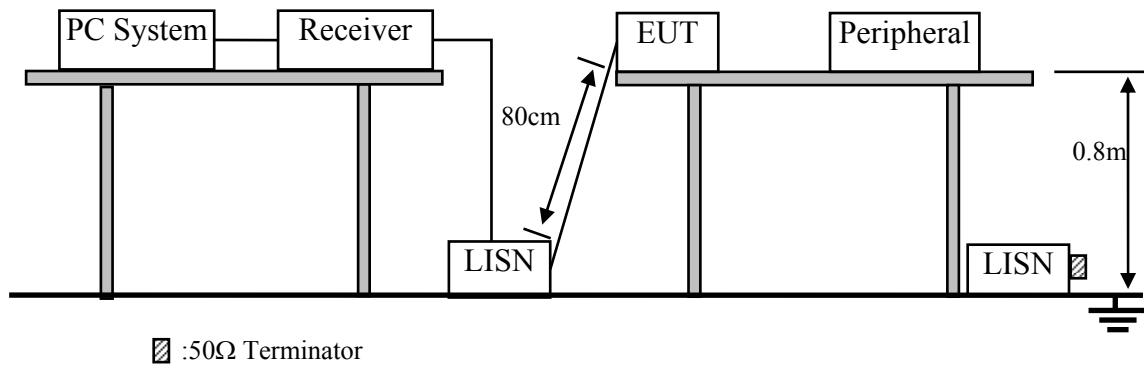

#### 3.3. Power Line Conducted Emission Test Limits

Frequency	Maximum RF Line Voltage	
	Quasi-Peak Level dB(μV)	Average Level dB(μV)
150kHz ~ 500kHz	66 ~ 56*	56 ~ 46*
500kHz ~ 5MHz	56	46
5MHz ~ 30MHz	60	50

Notes: 1. \* Decreasing linearly with logarithm of frequency.

2. The lower limit shall apply at the transition frequencies.

### 3.4. Configuration of EUT on Test

The following equipment are installed on Power Line Conducted Emission Test to meet the commission requirement and operating regulations in a manner which tends to maximize its emission characteristics in a normal application.

#### 3.4.1. Complex Set-Top Box (EUT)

Model Number : P2571

Serial Number : N/A

3.4.2. Support Equipment: As Tested Supporting System Details, in Section 2.2.

### 3.5. Operating Condition of EUT

3.5.1. Setup the EUT and simulator as shown as Section 3.2.

3.5.2. Turned on the power of all equipment.

3.5.3. PC run test software to control EUT work in Tx mode.

### 3.6. Test Procedure

The EUT was placed on a non-metallic table, 80cm above the ground plane. The EUT Power Via PC connected to the power mains through a line impedance stabilization network (L.I.S.N. 1#). This provides a 50 ohm coupling impedance for the EUT (Please refer the block diagram of the test setup and photographs). The AC line are checked to find out the maximum conducted emission. In order to find the maximum emission levels, the relative positions of equipment and all of the interface cables shall be changed according to ANSI C63.10: 2009 on Conducted Emission Test.

The bandwidth of test receiver (R & S ESHS10) is set at 9kHz.

The frequency range from 150kHz to 30MHz is checked.

### 3.7. Power Line Conducted Emission Test Results

**PASS.** (All emissions not reported below are too low against the prescribed limits.)

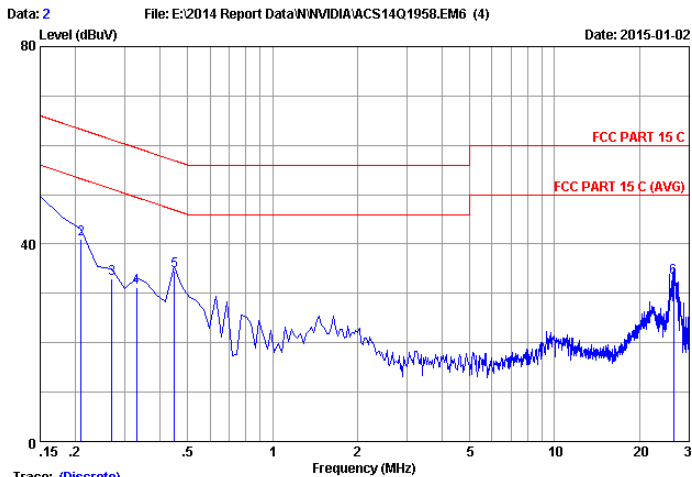

Trace: (Discrete)

Site no	:1#conduction	Data No	:2
Dis./Ant.	:2014 ESH2-25 LINE		
Limit	:FCC PART 15 C		
Env./Ins.	:24.6°C/50.7%	Engineer	:Kobe-Huang
EUT	:Complex Set-Top Box M/N:P2571		
Power Rating	:DC 19V From Adapter Input AC 120V/60Hz		
Test Mode	:Tx Mode		

No	Freq (MHz)	LISN Factor (dB)	Cable Loss (dB)	Reading (dBuV)	Emission Level (dBuV)	Limits (dBuV)	Margin (dB)	Remark
1	0.15000	0.14	9.89	37.63	47.66	66.00	18.34	QP
2	0.20970	0.13	9.90	31.00	41.03	63.22	22.19	QP
3	0.26940	0.13	9.90	23.03	33.06	61.14	28.08	QP
4	0.32910	0.14	9.90	21.10	31.14	59.47	28.33	QP
5	0.44850	0.50	9.90	24.10	34.50	56.90	22.40	QP
6	26.418	0.62	10.18	22.38	33.18	60.00	26.82	QP

Remarks: 1.Emission Level=LISN Factor+Cable Loss(Include 10dB pulse limit)+Reading.  
 2.If the average limit is met when using a quasi-peak detector, the EUT shall be deemed to meet both limits and measurement with average detector is unnecessary.

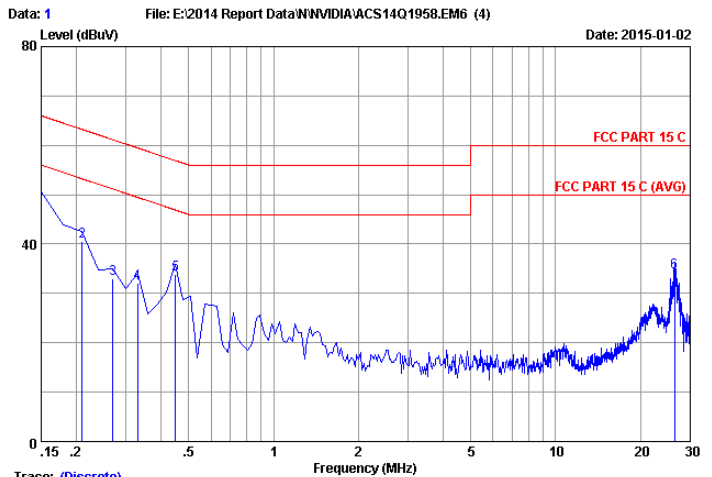

Trace: (Discrete)

Site no	:1#conduction	Data No	:1
Dis./Ant.	:2014 ESH2-25 NEUTRAL		
Limit	:FCC PART 15 C		
Env./Ins.	:24.6°C/50.7%	Engineer	:Kobe-Huang
EUT	:Complex Set-Top Box M/N:P2571		
Power Rating	:DC 19V From Adapter Input AC 120V/60Hz		
Test Mode	:Tx Mode		

No	Freq (MHz)	LISN Factor (dB)	Cable Loss (dB)	Reading (dBuV)	Emission Level (dBuV)	Limits (dBuV)	Margin (dB)	Remark
1	0.15000	0.13	9.89	38.60	48.62	66.00	17.38	QP
2	0.20970	0.13	9.90	30.54	40.57	63.22	22.65	QP
3	0.26940	0.14	9.90	22.93	32.97	61.14	28.17	QP
4	0.32910	0.15	9.90	22.01	32.06	59.47	27.41	QP
5	0.44850	0.16	9.90	23.73	33.79	56.90	23.11	QP
6	26.448	0.77	10.18	23.34	34.29	60.00	25.71	QP

Remarks: 1.Emission Level=LISN Factor+Cable Loss(Include 10dB pulse limit)+Reading.  
 2.If the average limit is met when using a quasi-peak detector, the EUT shall be deemed to meet both limits and measurement with average detector is unnecessary.

## 4. RADIATED EMISSION TEST

### 4.1. Test Equipment

#### 4.1.1. For frequency range 30MHz~1000MHz (At Anechoic Chamber)

Item	Equipment	Manufacturer	Model No.	Serial No.	Last Cal.	Cal. Interval
1.	3#Chamber	AUDIX	N/A	N/A	Nov.23, 14	1 Year
2.	EMI Spectrum	Agilent	E4407B	MY41440292	Apr. 28,14	1 Year
3.	Test Receiver	Rohde & Schwarz	ESVS10	834468/011	Apr. 28,14	1 Year
4.	Amplifier	HP	8447D	2648A04738	Apr. 28,14	1 Year
5.	Bilog Antenna	TESEQ	CBL6112D	35375	Jun. 18, 14	1 Year
6.	RF Cable	MIYAZAKI	CFD400-NL	3# Chamber No.1	Apr. 28,14	1 Year
7.	Coaxial Switch	Anritsu	MP59B	6200313662	Apr. 28,14	1 Year

#### 4.1.2. For frequency range 1GHz~40GHz (At Anechoic Chamber)

Item	Equipment	Manufacturer	Model No.	Serial No.	Last Cal.	Cal. Interval
1.	3#Chamber	AUDIX	N/A	N/A	Nov.02, 14	1 Year
2.	Spectrum Analyzer	Agilent	E4407B	MY41440292	Apr. 28,14	1 Year
3.	Horn Antenna	ETS	3115	9607-4877	Jun. 06, 14	1 Year
4.	Amplifier	Agilent	8449B	3008A00863	Apr. 28,14	1 Year
5.	RF Cable	Hubersuhner	SUCOFLEX106	77977/6	Apr. 28,14	1 Year
6.	RF Cable	Hubersuhner	SUCOFLEX106	28616/2	Apr. 28,14	1 Year
7.	Horn Antenna	ETS	3116	00060089	Sep.20, 14	1 Year

### 4.2. Block Diagram of Test Setup

For frequency range 30MHz-1000MHz

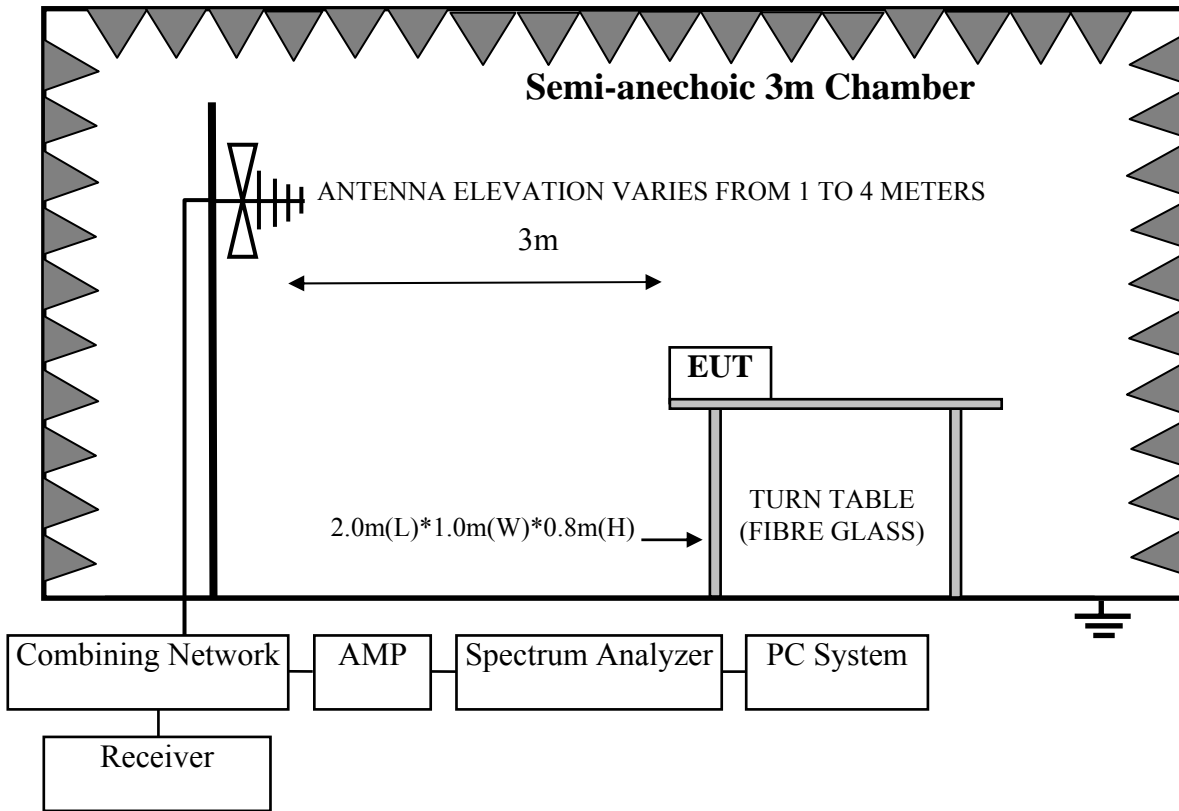

For frequency range 1GHz-25GHz

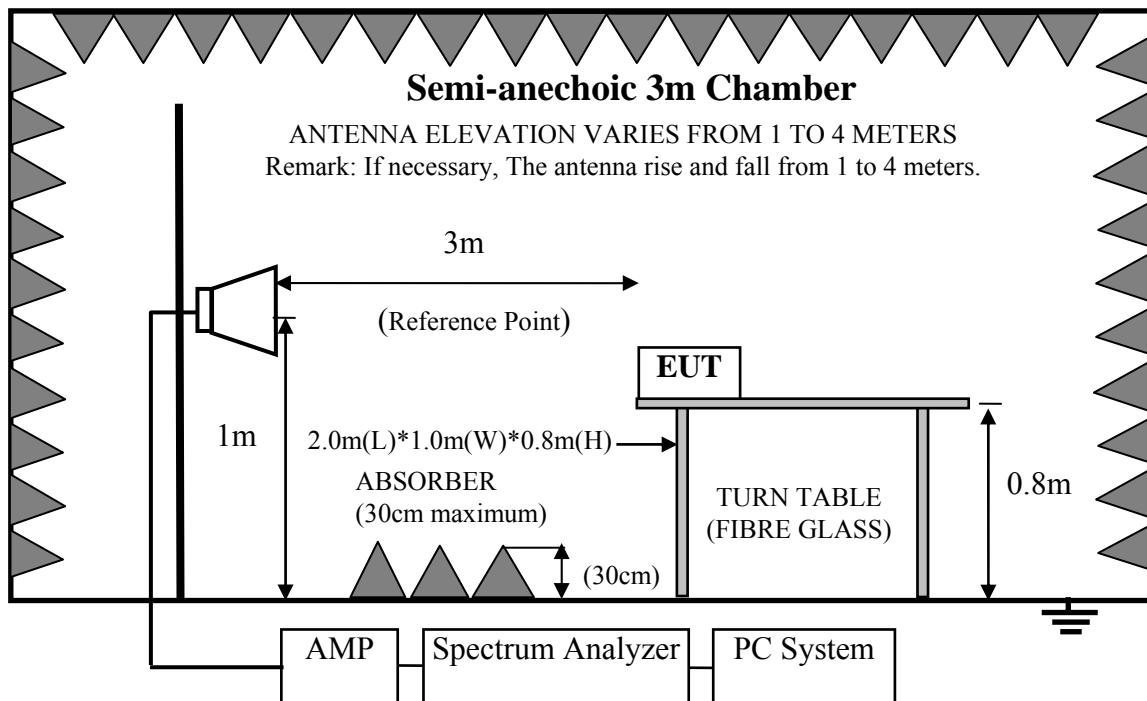

### 4.3. Radiated Emission Limit

#### 4.3.1. 15.247&209 limits

FREQUENCY MHz	DISTANCE Meters	FIELD STRENGTHS LIMIT	
		μV/m	dB(μV)/m
30 ~ 88	3	100	40.0
88 ~ 216	3	150	43.5
216 ~ 960	3	200	46.0
960 ~ 1000	3	500	54.0
Above 1000	3	74.0 dB(μV)/m (Peak) 54.0 dB(μV)/m (Average)	

Remark : (1) Emission level dBμV = 20 log Emission level μV/m

(2) The smaller limit shall apply at the cross point between two frequency bands.

(3) Distance is the distance in meters between the measuring instrument, antenna and the closest point of any part of the device or system.

#### 4.3.2. 15.205 Restricted bands of operation

MHz	MHz	MHz	GHz
0.090 - 0.110	16.42 - 16.423	399.9 - 410	4.5 - 5.15
<sup>1</sup> 0.495 - 0.505	16.69475 - 16.69525	608 - 614	5.35 - 5.46
2.1735 - 2.1905	16.80425 - 16.80475	960 - 1240	7.25 - 7.75
4.125 - 4.128	25.5 - 25.67	1300 - 1427	8.025 - 8.5
4.17725 - 4.17775	37.5 - 38.25	1435 - 1626.5	9.0 - 9.2
4.20725 - 4.20775	73 - 74.6	1645.5 - 1646.5	9.3 - 9.5
6.215 - 6.218	74.8 - 75.2	1660 - 1710	10.6 - 12.7
6.26775 - 6.26825	108 - 121.94	1718.8 - 1722.2	13.25 - 13.4
6.31175 - 6.31225	123 - 138	2200 - 2300	14.47 - 14.5
8.291 - 8.294	149.9 - 150.05	2310 - 2390	15.35 - 16.2
8.362 - 8.366	156.52475 - 156.52525	2483.5 - 2500	17.7 - 21.4
8.37625 - 8.38675	156.7 - 156.9	2690 - 2900	22.01 - 23.12
8.41425 - 8.41475	162.0125 - 167.17	3260 - 3267	23.6 - 24.0
12.29 - 12.293	167.72 - 173.2	3332 - 3339	31.2 - 31.8
12.51975 - 12.52025	240 - 285	3345.8 - 3358	36.43 - 36.5
12.57675 - 12.57725	322 - 335.4	3600 - 4400	( <sup>2</sup> )

All the emissions appearing within 15.205 restricted frequency bands shall not exceed the limits shown in 15.209, all the other emissions shall be at least 20dB below the fundamental emissions or comply with 15.209 limits.

### 4.4. EUT Configuration on Test

The configurations of EUT are listed in Section 3.4.

### 4.5. Operating Condition of EUT

Same as Conducted Emission test that is listed in Section 3.5. except the test set up replaced by Section 4.2.

#### 4.6. Test Procedure

EUT and its simulators are placed on a turn table, which is 0.8 meter high above ground. The turn table can rotate 360 degrees to determine the position of the maximum emission level. Power on the EUT and let it working in test mode, then test it. EUT is set 3 meters away from the receiving antenna, which is mounted on a antenna tower. The antenna can be moved up and down between 1 meter and 4 meters to find out the maximum emission level. Broadband antenna (calibrated bilog antenna) is used as receiving antenna. Both horizontal and vertical polarization of the antenna are set on test.

This test was performed with EUT in X, Y, Z position, and the worse case was found when EUT in X position as test photo indicated.

The bandwidth of the EMI test receiver (R&S ESVS10) is set at 120kHz for frequency range from 30MHz to 1000 MHz.

The bandwidth of the Spectrum's VBW is set at 3MHz and RBW is set at 1MHz for peak emissions measurement above 1GHz and 1MHz RBW, 10Hz VBW for average emissions measure above 1GHz

The frequency range from 30MHz to 10<sup>th</sup> harmonic (25GHz) are checked. and no any emissions were found from 18GHz to 25GHz, So the radiated emissions from 18GHz to 25GHz were not record.

#### 4.7. Radiated Emission Test Results

**PASS.**

All the emissions from 30MHz to 25 GHz were comply with 15.209 limits.

Note: For emissions above 1GHz, if peak level comply with average limit, then the average level is deemed to comply with average limit.

Mode	Emission Level* (dB $\mu$ V/m)	EIRP (dBm/MHz)	Limit (dBm/MHz)	Conclusion
11b	56.24	-38.96	-27	Pass
11g	55.33	-39.87	-27	Pass
11n HT20	55.64	-39.56	-27	Pass
11n HT40	54.60	-40.6	-27	Pass

\* The worse case result for each mode.



### Duty cycle

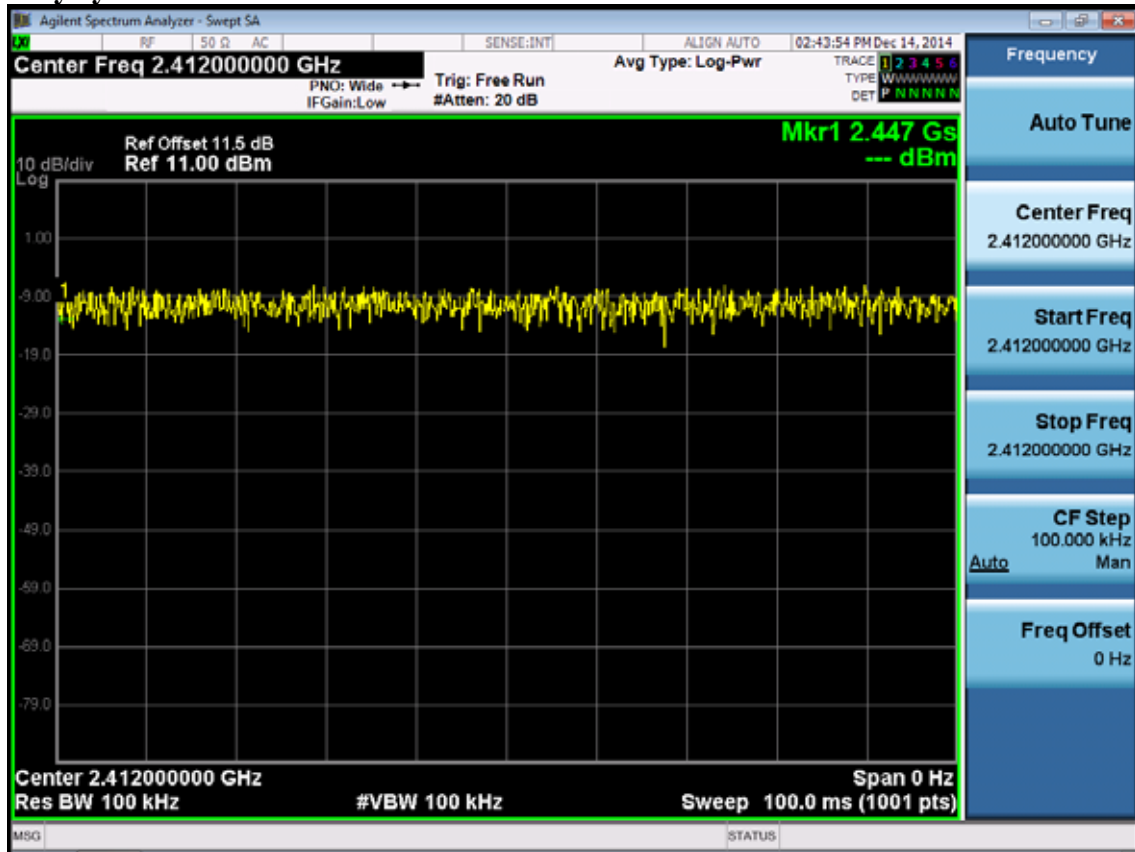

**Note: The Duty Cycle is close to 100%.**

### Frequency: 30MHz~1GHz

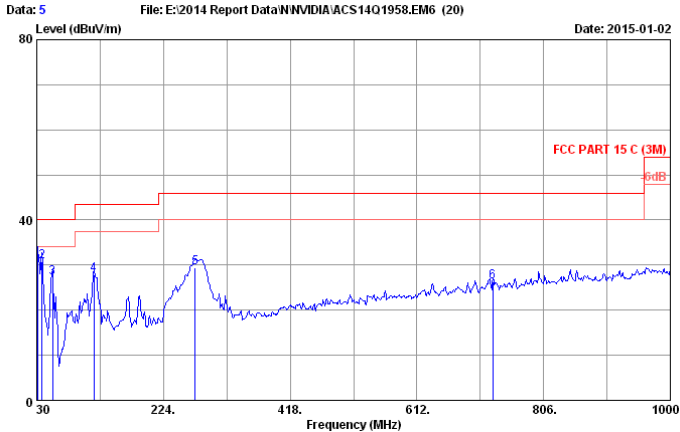

Site no. : 3m Chamber Data no. : 5  
 Dis. / Ant. : 3m 2014 CBL6112D 35375 Ant. pol. : HORIZONTAL  
 Limit : FCC PART 15 C (3M)  
 Env. / Ins. : 26.9°C/50% Engineer : Kobe-Huang  
 EUT : Complex Set-Top Box  
 Power rating : DC 19V From Adapter Input AC 120V/60Hz  
 Test Mode : TX Mode  
 M/N : P2571

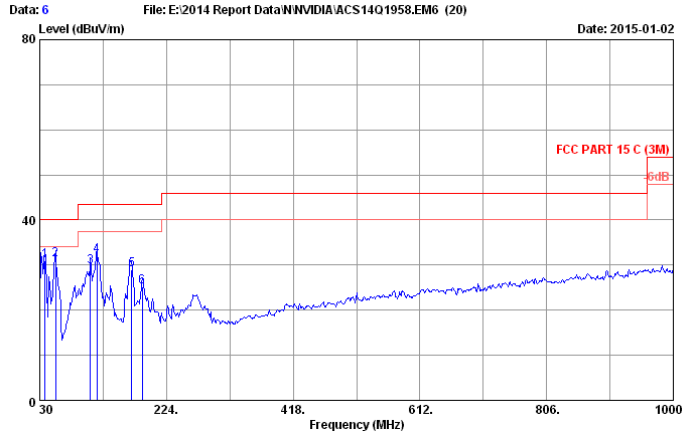

Site no. : 3m Chamber Data no. : 6  
 Dis. / Ant. : 3m 2014 CBL6112D 35375 Ant. pol. : VERTICAL  
 Limit : FCC PART 15 C (3M)  
 Env. / Ins. : 26.9°C/50% Engineer : Kobe-Huang  
 EUT : Complex Set-Top Box  
 Power rating : DC 19V From Adapter Input AC 120V/60Hz  
 Test Mode : TX Mode  
 M/N : P2571

No.	Freq. (MHz)	Ant. Factor (dB/m)	Cable Loss (dB)	Reading (dBuV)	Emission Level (dBuV/m)	Limits (dBuV/m)	Margin (dB)	Remark
1	31.940	18.82	0.62	11.90	31.34	40.00	8.66	QP
2	37.760	15.07	0.68	15.06	30.81	40.00	9.19	QP
3	54.250	7.47	0.81	18.99	27.27	40.00	12.73	QP
4	117.300	12.66	1.28	14.01	27.95	43.50	15.55	QP
5	272.500	13.50	2.17	13.68	29.35	46.00	16.65	QP
6	728.400	20.30	4.23	1.75	26.28	46.00	19.72	QP

Remarks: 1. Emission Level= Antenna Factor + Cable Loss + Reading.  
 2. The emission levels that are 20dB below the official limit are not reported.

No.	Freq. (MHz)	Ant. Factor (dB/m)	Cable Loss (dB)	Reading (dBuV)	Emission Level (dBuV/m)	Limits (dBuV/m)	Margin (dB)	Remark
1	37.760	15.07	0.68	15.13	30.88	40.00	9.12	QP
2	54.250	7.47	0.81	22.86	31.14	40.00	8.86	QP
3	107.600	11.98	1.19	16.55	29.72	43.50	13.78	QP
4	117.300	12.66	1.28	18.15	32.09	43.50	11.41	QP
5	170.650	10.07	1.67	17.18	28.92	43.50	14.58	QP
6	187.140	9.70	1.77	13.70	25.17	43.50	18.33	QP

Remarks: 1. Emission Level= Antenna Factor + Cable Loss + Reading.  
 2. The emission levels that are 20dB below the official limit are not reported.

### Frequency: 1GHz~18GHz Test Mode: IEEE 802.11b

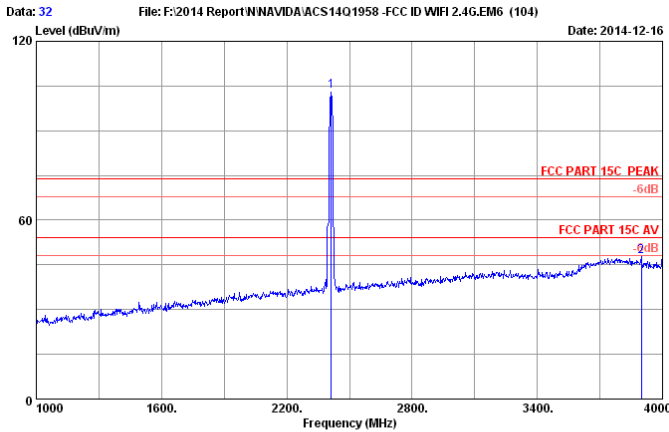

Site no. : 3m Chamber Data no. : 32  
 Dis. / Ant. : 3m 2014 3115 (4580) Ant. pol. : HORIZONTAL  
 Limit : FCC PART 15C PEAK  
 Env. / Ins. : 23°C/54%  
 Engineer : Kobe-Huang  
 EUT : Complex Set-Top Box  
 Power rating : DC 19V From Adapter Input AC 120V/60Hz  
 Test Mode : IEEE802.11b 2412MHz Tx Mode  
 M/N : P2571

No.	Freq. (MHz)	Ant. Factor (dB/m)	Cable Loss (dB)	AMP factor (dB)	Reading (dBuV)	Emission Level (dBuV/m)	Limits (dBuV/m)	Margin (dB)	Remark
1	2412.000	28.21	5.81	35.70	104.84	103.16	74.00	-29.16	Peak
2	3898.000	32.36	7.61	35.70	43.49	47.76	74.00	26.24	Peak

Remarks: 1. Emission Level= Antenna Factor + Cable Loss + Reading - Amp Factor  
 2. The emission levels that are 20dB below the official limit are not reported.

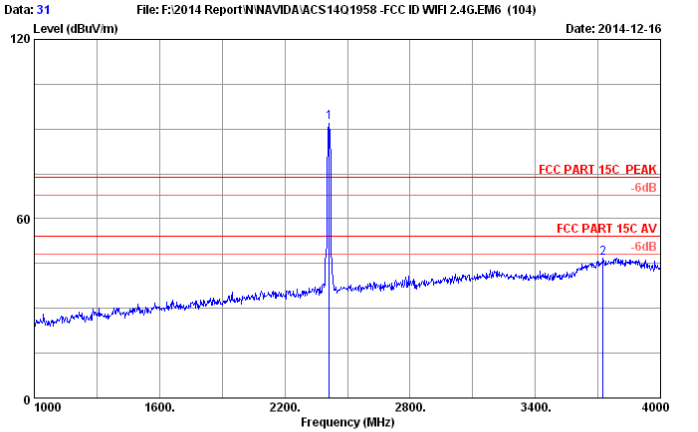

Site no. : 3m Chamber Data no. : 31  
 Dis. / Ant. : 3m 2014 3115 (4580) Ant. pol. : VERTICAL  
 Limit : FCC PART 15C PEAK  
 Env. / Ins. : 23°C/54%  
 Engineer : Kobe-Huang  
 EUT : Complex Set-Top Box  
 Power rating : DC 19V From Adapter Input AC 120V/60Hz  
 Test Mode : IEEE802.11b 2412MHz Tx Mode  
 M/N : P2571

No.	Freq. (MHz)	Ant. Factor (dB/m)	Cable Loss (dB)	AMP factor (dB)	Reading (dBuV)	Emission Level (dBuV/m)	Limits (dBuV/m)	Margin (dB)	Remark
1	2412.000	28.21	5.81	35.70	93.79	92.11	74.00	-18.11	Peak
2	3724.000	31.94	7.43	35.70	43.09	46.76	74.00	27.24	Peak

Remarks: 1. Emission Level= Antenna Factor + Cable Loss + Reading - Amp Factor  
 2. The emission levels that are 20dB below the official limit are not reported.

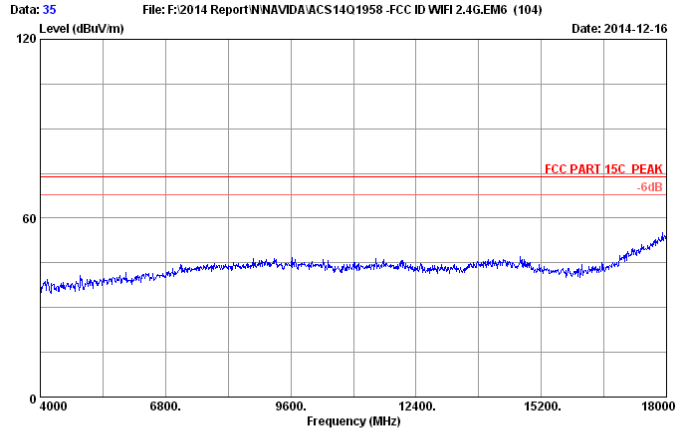
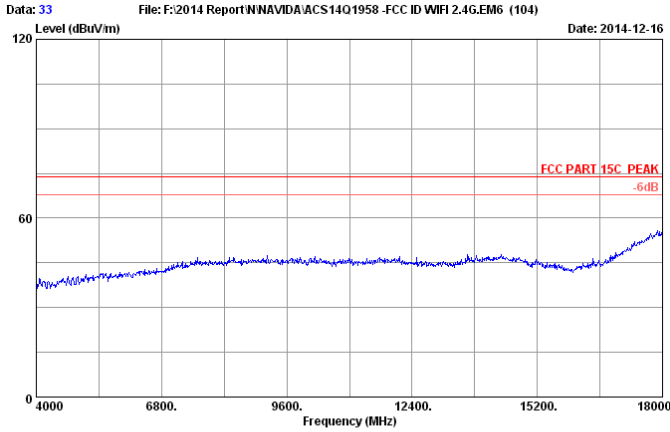

Site no. : 3m Chamber Data no. : 33  
 Dis. / Ant. : 3m 2014 3115 (4580) Ant. pol. : HORIZONTAL  
 Limit : FCC PART 15C PEAK  
 Env. / Ins. : 23°C/54%  
 Engineer : Kobe-Huang  
 EUT : Complex Set-Top Box  
 Power rating : DC 19V From Adpater Input AC 120V/60Hz  
 Test Mode : IEEE802.11b 2412MHz Tx Mode  
 M/N : P2571

Site no. : 3m Chamber Data no. : 35  
 Dis. / Ant. : 3m 2014 3115 (4580) Ant. pol. : VERTICAL  
 Limit : FCC PART 15C PEAK  
 Env. / Ins. : 23°C/54%  
 Engineer : Kobe-Huang  
 EUT : Complex Set-Top Box  
 Power rating : DC 19V From Adpater Input AC 120V/60Hz  
 Test Mode : IEEE802.11b 2412MHz Tx Mode  
 M/N : P2571

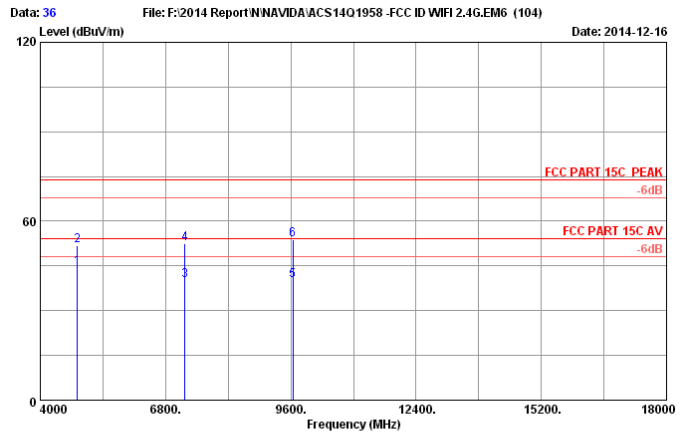
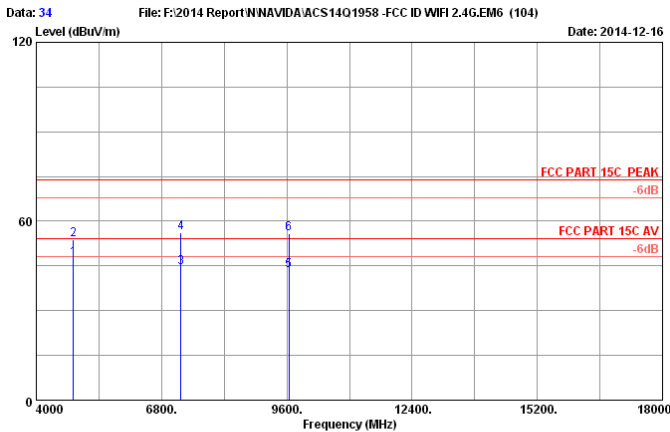

Site no. : 3m Chamber Data no. : 34  
 Dis. / Ant. : 3m 2014 3115 (4580) Ant. pol. : HORIZONTAL  
 Limit : FCC PART 15C PEAK  
 Env. / Ins. : 23°C/54%  
 Engineer : Kobe-Huang  
 EUT : Complex Set-Top Box  
 Power rating : DC 19V From Adpater Input AC 120V/60Hz  
 Test Mode : IEEE802.11b 2412MHz Tx Mode  
 M/N : P2571

Site no. : 3m Chamber Data no. : 36  
 Dis. / Ant. : 3m 2014 3115 (4580) Ant. pol. : VERTICAL  
 Limit : FCC PART 15C PEAK  
 Env. / Ins. : 23°C/54%  
 Engineer : Kobe-Huang  
 EUT : Complex Set-Top Box  
 Power rating : DC 19V From Adpater Input AC 120V/60Hz  
 Test Mode : IEEE802.11b 2412MHz Tx Mode  
 M/N : P2571

No.	Freq. (MHz)	Ant. Factor (dB/m)	Cable Loss (dB)	AMP factor (dB)	Reading (dBuV)	Emission Level (dBuV/m)	Limits (dBuV/m)	Margin (dB)	Remark
1	4824.000	32.88	8.58	35.70	41.86	47.62	54.00	6.38	Average
2	4824.000	32.88	8.58	35.70	48.21	53.97	74.00	20.03	Peak
3	7236.000	36.02	10.98	35.45	33.01	44.56	54.00	9.44	Average
4	7236.000	36.02	10.98	35.45	44.69	56.24	74.00	17.76	Peak
5	9648.000	37.79	12.25	35.46	28.73	43.31	54.00	10.69	Average
6	9648.000	37.79	12.25	35.46	41.19	55.77	74.00	18.23	Peak

Remarks: 1. Emission Level= Antenna Factor + Cable Loss + Reading - Amp Factor  
 2. The emission levels that are 20dB below the official limit are not reported.

No.	Freq. (MHz)	Ant. Factor (dB/m)	Cable Loss (dB)	AMP factor (dB)	Reading (dBuV)	Emission Level (dBuV/m)	Limits (dBuV/m)	Margin (dB)	Remark
1	4824.000	32.88	8.58	35.70	38.76	44.52	54.00	9.48	Average
2	4824.000	32.88	8.58	35.70	45.95	51.71	74.00	22.29	Peak
3	7236.000	36.02	10.98	35.45	28.52	40.07	54.00	13.93	Average
4	7236.000	36.02	10.98	35.45	40.76	52.31	74.00	21.69	Peak
5	9648.000	37.79	12.25	35.46	25.69	40.27	54.00	13.73	Average
6	9648.000	37.79	12.25	35.46	39.27	53.85	74.00	20.15	Peak

Remarks: 1. Emission Level= Antenna Factor + Cable Loss + Reading - Amp Factor  
 2. The emission levels that are 20dB below the official limit are not reported.

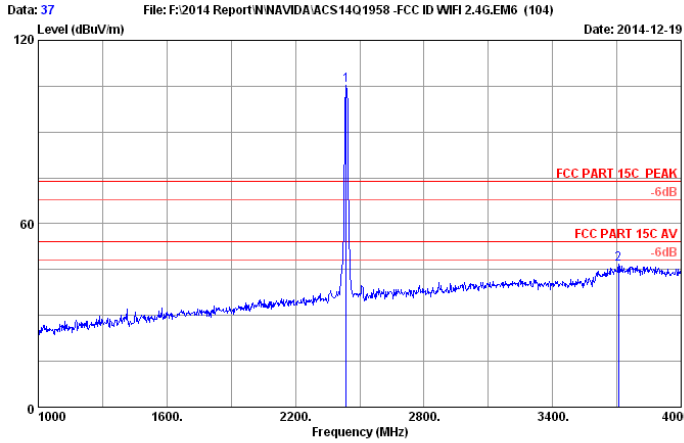

Site no. : 3m Chamber Data no. : 37  
 Dis. / Ant. : 3m 2014 3115 (4580) Ant. pol. : HORIZONTAL  
 Limit : FCC PART 15C PEAK  
 Env. / Ins. : 23°C/54%  
 Engineer : Kobe-Huang  
 EUT : Complex Set-Top Box  
 Power rating : DC 19V From Adppter Input AC 120V/60Hz  
 Test Mode : IEEEE02.11b 2437MHz Tx Mode  
 M/N : P2571

No.	Freq. (MHz)	Ant. Factor (dB/m)	Cable Loss (dB)	AMP factor (dB)	Reading (dBuV)	Emission Level (dBuV/m)	Limits (dBuV/m)	Margin (dB)	Remark
1	2437.000	28.26	5.85	35.70	106.74	105.15	74.00	-31.15	Peak
2	3709.000	31.90	7.41	35.70	43.26	46.87	74.00	27.13	Peak

Remarks: 1. Emission Level= Antenna Factor + Cable Loss + Reading -amp Factor  
 2. The emission levels that are 20dB below the official limit are not reported.

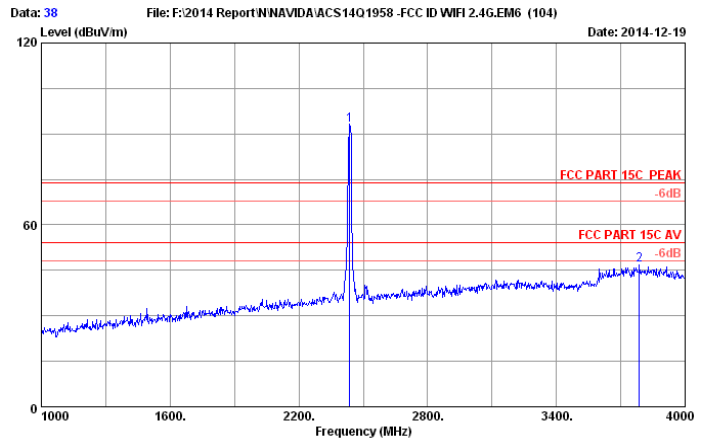

Site no. : 3m Chamber Data no. : 38  
 Dis. / Ant. : 3m 2014 3115 (4580) Ant. pol. : VERTICAL  
 Limit : FCC PART 15C PEAK  
 Env. / Ins. : 23°C/54%  
 Engineer : Kobe-Huang  
 EUT : Complex Set-Top Box  
 Power rating : DC 19V From Adppter Input AC 120V/60Hz  
 Test Mode : IEEEE02.11b 2437MHz Tx Mode  
 M/N : P2571

No.	Freq. (MHz)	Ant. Factor (dB/m)	Cable Loss (dB)	AMP factor (dB)	Reading (dBuV)	Emission Level (dBuV/m)	Limits (dBuV/m)	Margin (dB)	Remark
1	2437.000	28.26	5.85	35.70	94.67	93.08	74.00	-19.08	Peak
2	3787.000	32.09	7.49	35.70	42.89	46.77	74.00	27.23	Peak

Remarks: 1. Emission Level= Antenna Factor + Cable Loss + Reading -amp Factor  
 2. The emission levels that are 20dB below the official limit are not reported.

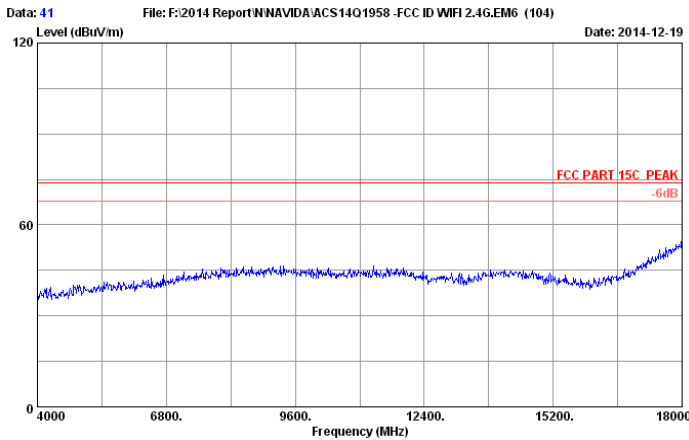

Site no. : 3m Chamber Data no. : 41  
 Dis. / Ant. : 3m 2014 3115 (4580) Ant. pol. : HORIZONTAL  
 Limit : FCC PART 15C PEAK  
 Env. / Ins. : 23°C/54%  
 Engineer : Kobe-Huang  
 EUT : Complex Set-Top Box  
 Power rating : DC 19V From Adppter Input AC 120V/60Hz  
 Test Mode : IEEEE02.11b 2437MHz Tx Mode  
 M/N : P2571

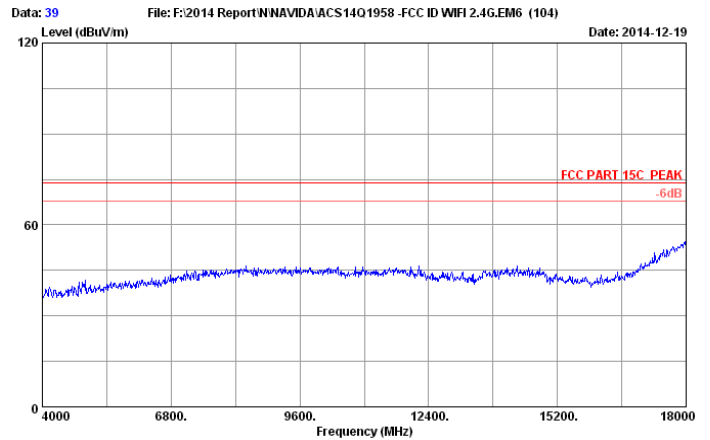

Site no. : 3m Chamber Data no. : 39  
 Dis. / Ant. : 3m 2014 3115 (4580) Ant. pol. : VERTICAL  
 Limit : FCC PART 15C PEAK  
 Env. / Ins. : 23°C/54%  
 Engineer : Kobe-Huang  
 EUT : Complex Set-Top Box  
 Power rating : DC 19V From Adppter Input AC 120V/60Hz  
 Test Mode : IEEEE02.11b 2437MHz Tx Mode  
 M/N : P2571

Data: 42 File: F:\2014 Report\NNAVIDA\ACS14Q1958 -FCC ID WIFI 2.4G.EM6 (104) Date: 2014-12-19

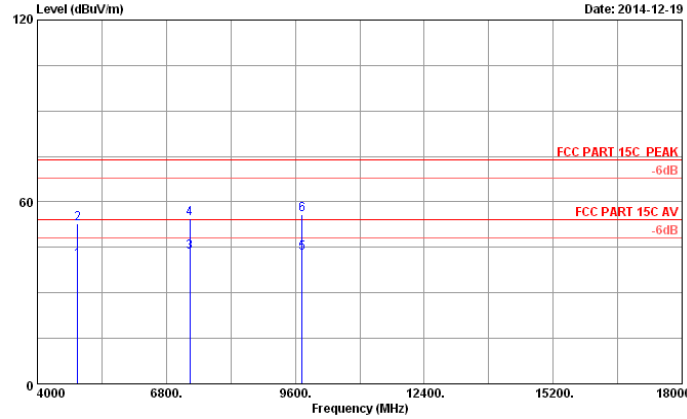

Site no. : 3m Chamber Data no. : 42  
 Dis. / Ant. : 3m 2014 3115 (4580) Ant. pol. : HORIZONTAL  
 Limit : FCC PART 15C PEAK  
 Env. / Ins. : 23°C/54%  
 Engineer : Kobe-Huang  
 EUT : Complex Set-Top Box  
 Power rating : DC 19V From Adpater Input AC 120V/60Hz  
 Test Mode : IEEE802.11b 2437MHz Tx Mode  
 M/N : P2571

No.	Freq. (MHz)	Ant. Factor (dB/m)	Cable Loss (dB)	AMP factor (dB)	Reading (dBuV)	Emission Level (dBuV/m)	Limits (dBuV/m)	Margin (dB)	Remark
1	4874.000	32.97	8.63	35.70	34.80	40.70	54.00	13.30	Average
2	4874.000	32.97	8.63	35.70	46.93	52.83	74.00	21.17	Peak
3	7311.000	36.18	11.02	35.44	31.79	43.55	54.00	10.45	Average
4	7311.000	36.18	11.02	35.44	42.67	54.43	74.00	19.57	Peak
5	9748.000	37.85	12.30	35.47	28.44	43.12	54.00	10.88	Average
6	9748.000	37.85	12.30	35.47	41.24	55.92	74.00	18.08	Peak

Remarks: 1. Emission Level= Antenna Factor + Cable Loss + Reading - Amp Factor  
 2. The emission levels that are 20dB below the official limit are not reported.

Data: 40 File: F:\2014 Report\NNAVIDA\ACS14Q1958 -FCC ID WIFI 2.4G.EM6 (104) Date: 2014-12-19

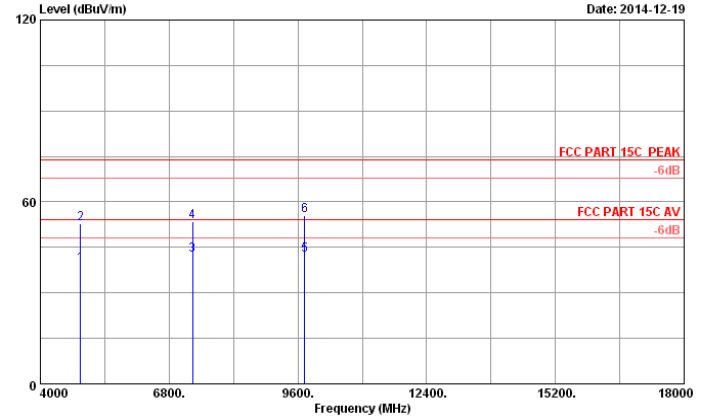

Site no. : 3m Chamber Data no. : 40  
 Dis. / Ant. : 3m 2014 3115 (4580) Ant. pol. : VERTICAL  
 Limit : FCC PART 15C PEAK  
 Env. / Ins. : 23°C/54%  
 Engineer : Kobe-Huang  
 EUT : Complex Set-Top Box  
 Power rating : DC 19V From Adpater Input AC 120V/60Hz  
 Test Mode : IEEE802.11b 2437MHz Tx Mode  
 M/N : P2571

No.	Freq. (MHz)	Ant. Factor (dB/m)	Cable Loss (dB)	AMP factor (dB)	Reading (dBuV)	Emission Level (dBuV/m)	Limits (dBuV/m)	Margin (dB)	Remark
1	4874.000	32.97	8.63	35.70	33.69	39.59	54.00	14.41	Average
2	4874.000	32.97	8.63	35.70	46.80	52.70	74.00	21.30	Peak
3	7311.000	36.18	11.02	35.44	30.85	42.61	54.00	11.39	Average
4	7311.000	36.18	11.02	35.44	41.58	53.34	74.00	20.66	Peak
5	9748.000	37.85	12.30	35.47	27.83	42.51	54.00	11.49	Average
6	9748.000	37.85	12.30	35.47	40.86	55.54	74.00	18.46	Peak

Remarks: 1. Emission Level= Antenna Factor + Cable Loss + Reading - Amp Factor  
 2. The emission levels that are 20dB below the official limit are not reported.

Data: 51 File: F:\2014 Report\NNAVIDA\ACS14Q1958 -FCC ID WIFI 2.4G.EM6 (104) Date: 2014-12-16

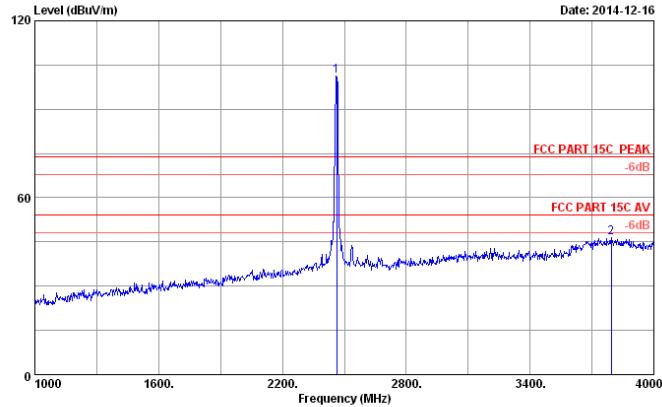

Site no. : 3m Chamber Data no. : 51  
 Dis. / Ant. : 3m 2014 3115 (4580) Ant. pol. : HORIZONTAL  
 Limit : FCC PART 15C PEAK  
 Env. / Ins. : 23°C/54%  
 Engineer : Kobe-Huang  
 EUT : Complex Set-Top Box  
 Power rating : DC 19V From Adpater Input AC 120V/60Hz  
 Test Mode : IEEE802.11b 2462MHz Tx Mode  
 M/N : P2571

No.	Freq. (MHz)	Ant. Factor (dB/m)	Cable Loss (dB)	AMP factor (dB)	Reading (dBuV)	Emission Level (dBuV/m)	Limits (dBuV/m)	Margin (dB)	Remark
1	2462.000	28.32	5.89	35.70	102.83	101.34	74.00	-27.34	Peak
2	3793.000	32.10	7.50	35.70	42.51	46.41	74.00	27.59	Peak

Remarks: 1. Emission Level= Antenna Factor + Cable Loss + Reading - Amp Factor  
 2. The emission levels that are 20dB below the official limit are not reported.

Data: 52 File: F:\2014 Report\NNAVIDA\ACS14Q1958 -FCC ID WIFI 2.4G.EM6 (104) Date: 2014-12-16

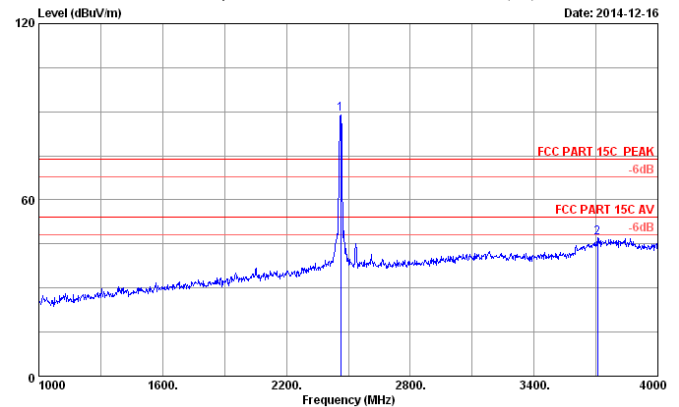

Site no. : 3m Chamber Data no. : 52  
 Dis. / Ant. : 3m 2014 3115 (4580) Ant. pol. : VERTICAL  
 Limit : FCC PART 15C PEAK  
 Env. / Ins. : 23°C/54%  
 Engineer : Kobe-Huang  
 EUT : Complex Set-Top Box  
 Power rating : DC 19V From Adpater Input AC 120V/60Hz  
 Test Mode : IEEE802.11b 2462MHz Tx Mode  
 M/N : P2571

No.	Freq. (MHz)	Ant. Factor (dB/m)	Cable Loss (dB)	AMP factor (dB)	Reading (dBuV)	Emission Level (dBuV/m)	Limits (dBuV/m)	Margin (dB)	Remark
1	2462.000	28.32	5.89	35.70	90.73	89.24	74.00	-15.24	Peak
2	3709.000	31.90	7.41	35.70	43.47	47.08	74.00	26.92	Peak

Remarks: 1. Emission Level= Antenna Factor + Cable Loss + Reading - Amp Factor  
 2. The emission levels that are 20dB below the official limit are not reported.

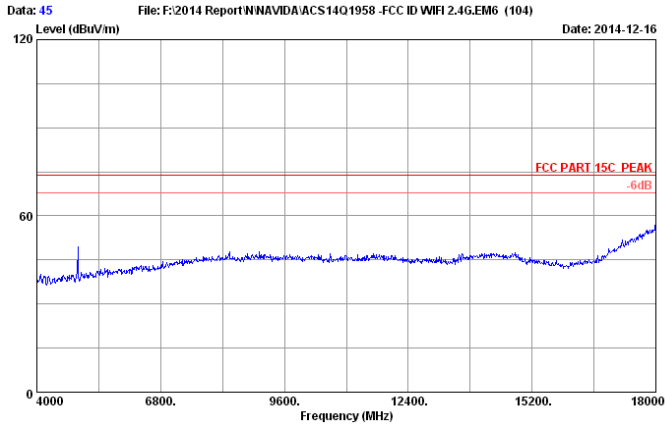

Site no. : 3m Chamber Data no. : 45  
 Dis. / Ant. : 3m 2014 3115 (4580) Ant. pol. : HORIZONTAL  
 Limit : FCC PART 15C PEAK  
 Env. / Ins. : 23°C/54%  
 Engineer : Kobe-Huang  
 EUT : Complex Set-Top Box  
 Power rating : DC 19V From Adpater Input AC 120V/60Hz  
 Test Mode : IEEE802.11b 2462MHz Tx Mode  
 M/N : P2571

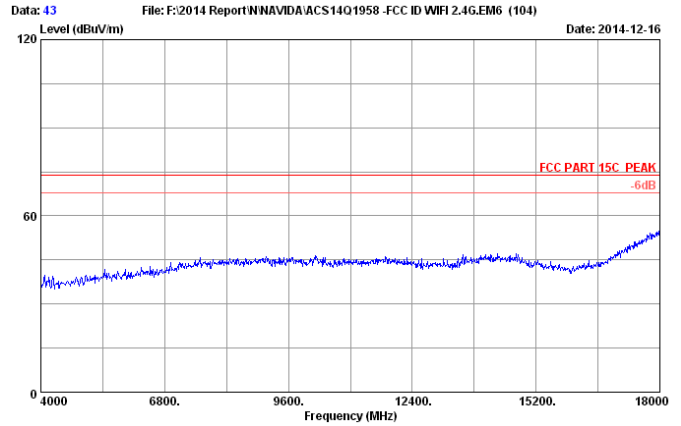

Site no. : 3m Chamber Data no. : 43  
 Dis. / Ant. : 3m 2014 3115 (4580) Ant. pol. : VERTICAL  
 Limit : FCC PART 15C PEAK  
 Env. / Ins. : 23°C/54%  
 Engineer : Kobe-Huang  
 EUT : Complex Set-Top Box  
 Power rating : DC 19V From Adpater Input AC 120V/60Hz  
 Test Mode : IEEE802.11b 2462MHz Tx Mode  
 M/N : P2571

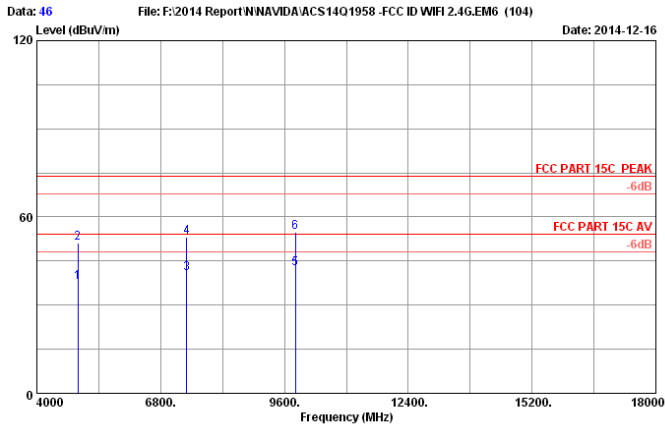

Site no. : 3m Chamber Data no. : 46  
 Dis. / Ant. : 3m 2014 3115 (4580) Ant. pol. : HORIZONTAL  
 Limit : FCC PART 15C PEAK  
 Env. / Ins. : 23°C/54%  
 Engineer : Kobe-Huang  
 EUT : Complex Set-Top Box  
 Power rating : DC 19V From Adpater Input AC 120V/60Hz  
 Test Mode : IEEE802.11b 2462MHz Tx Mode  
 M/N : P2571

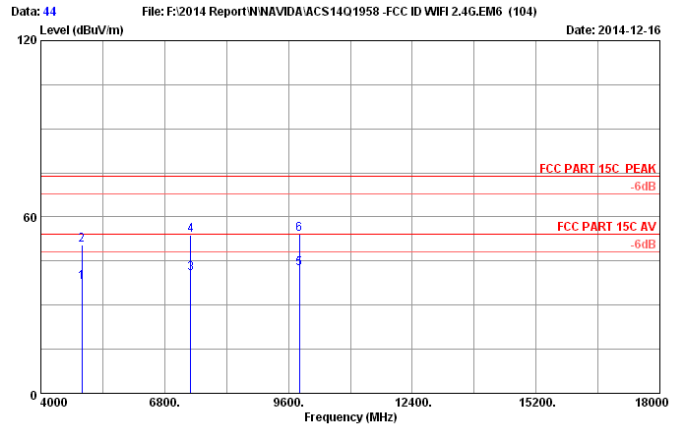

Site no. : 3m Chamber Data no. : 44  
 Dis. / Ant. : 3m 2014 3115 (4580) Ant. pol. : VERTICAL  
 Limit : FCC PART 15C PEAK  
 Env. / Ins. : 23°C/54%  
 Engineer : Kobe-Huang  
 EUT : Complex Set-Top Box  
 Power rating : DC 19V From Adpater Input AC 120V/60Hz  
 Test Mode : IEEE802.11b 2462MHz Tx Mode  
 M/N : P2571

No.	Freq. (MHz)	Ant. Factor (dB/m)	Cable Loss (dB)	AMP factor (dB)	Reading (dBuV)	Emission Level (dBuV/m)	Limits (dBuV/m)	Margin (dB)	Remark
1	4924.000	33.06	8.69	35.70	31.78	37.83	54.00	16.17	Average
2	4924.000	33.06	8.69	35.70	44.99	51.04	74.00	22.96	Peak
3	7386.000	36.35	11.06	35.42	28.85	40.84	54.00	13.16	Average
4	7386.000	36.35	11.06	35.42	41.28	53.27	74.00	20.73	Peak
5	9848.000	37.91	12.35	35.48	27.62	42.40	54.00	11.60	Average
6	9848.000	37.91	12.35	35.48	40.08	54.86	74.00	19.14	Peak

Remarks: 1. Emission Level= Antenna Factor + Cable Loss + Reading - Amp Factor  
 2. The emission levels that are 20dB below the official limit are not reported.

No.	Freq. (MHz)	Ant. Factor (dB/m)	Cable Loss (dB)	AMP factor (dB)	Reading (dBuV)	Emission Level (dBuV/m)	Limits (dBuV/m)	Margin (dB)	Remark
1	4924.000	33.06	8.69	35.70	31.75	37.80	54.00	16.20	Average
2	4924.000	33.06	8.69	35.70	44.31	50.36	74.00	23.64	Peak
3	7386.000	36.35	11.06	35.42	28.92	40.91	54.00	13.09	Average
4	7386.000	36.35	11.06	35.42	41.90	53.89	74.00	20.11	Peak
5	9848.000	37.91	12.35	35.48	27.64	42.42	54.00	11.58	Average
6	9848.000	37.91	12.35	35.48	39.38	54.16	74.00	19.84	Peak

Remarks: 1. Emission Level= Antenna Factor + Cable Loss + Reading - Amp Factor  
 2. The emission levels that are 20dB below the official limit are not reported.

**Test Mode: IEEE 802.11g**

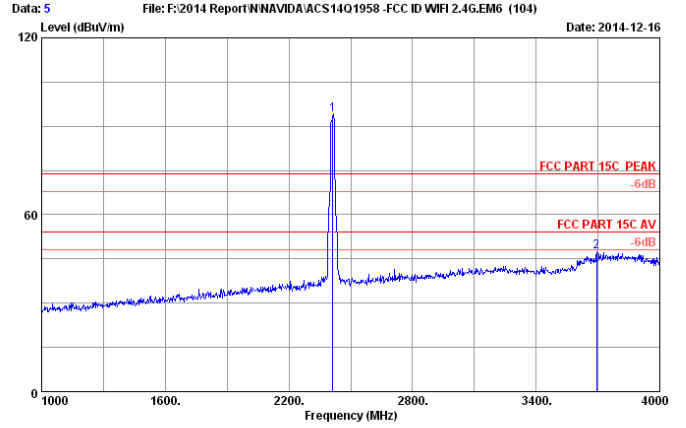
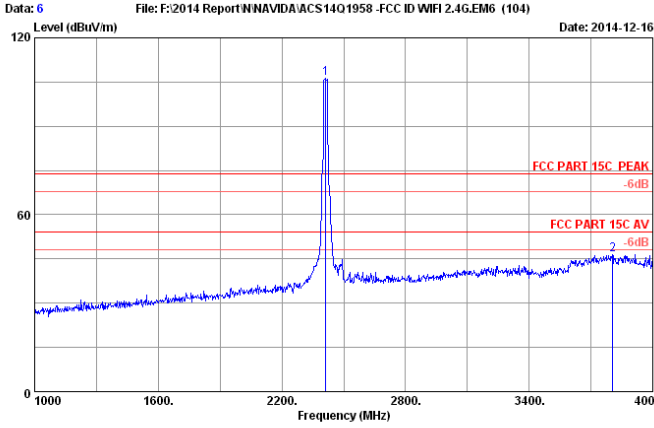

Site no. : 3m Chamber Data no. : 6  
 Dis. / Ant. : 3m 2014 3115 (4580) Ant. pol. : HORIZONTAL  
 Limit : FCC PART 15C PEAK  
 Env. / Ins. : 23°C/54%  
 Engineer : Kobe-Huang  
 EUT : Complex Set-Top Box  
 Power rating : DC 19V From Adpater Input AC 120V/60Hz  
 Test Mode : IEEE802.11g 2412MHz Tx Mode  
 M/N : P2571

Site no. : 3m Chamber Data no. : 5  
 Dis. / Ant. : 3m 2014 3115 (4580) Ant. pol. : VERTICAL  
 Limit : FCC PART 15C PEAK  
 Env. / Ins. : 23°C/54%  
 Engineer : Kobe-Huang  
 EUT : Complex Set-Top Box  
 Power rating : DC 19V From Adpater Input AC 120V/60Hz  
 Test Mode : IEEE802.11g 2412MHz Tx Mode  
 M/N : P2571

No.	Freq. (MHz)	Ant. Factor (dB/m)	Cable Loss (dB)	AMP factor (dB)	Reading (dBuV)	Emission Level (dBuV/m)	Limits (dBuV/m)	Margin (dB)	Remark
1	2412.000	28.21	5.81	35.70	107.91	106.23	74.00	-32.23	Peak
2	3805.000	32.13	7.51	35.70	42.50	46.44	74.00	27.56	Peak

No.	Freq. (MHz)	Ant. Factor (dB/m)	Cable Loss (dB)	AMP factor (dB)	Reading (dBuV)	Emission Level (dBuV/m)	Limits (dBuV/m)	Margin (dB)	Remark
1	2412.000	28.21	5.81	35.70	95.61	93.93	74.00	-19.93	Peak
2	3694.000	31.87	7.40	35.70	43.76	47.33	74.00	26.67	Peak

Remarks: 1. Emission Level= Antenna Factor + Cable Loss + Reading - Amp Factor  
 2. The emission levels that are 20dB below the official limit are not reported.

Remarks: 1. Emission Level= Antenna Factor + Cable Loss + Reading - Amp Factor  
 2. The emission levels that are 20dB below the official limit are not reported.

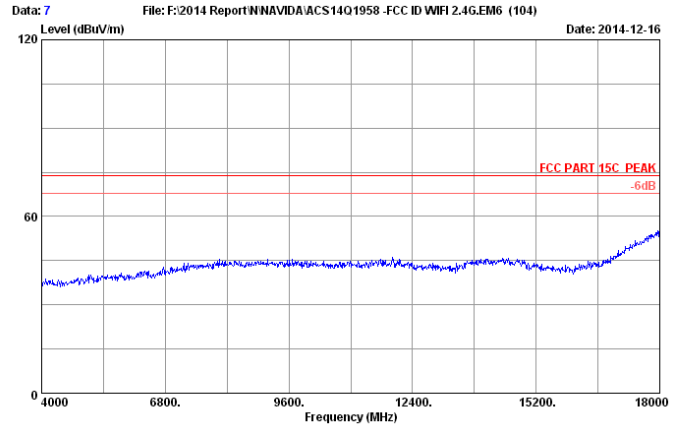
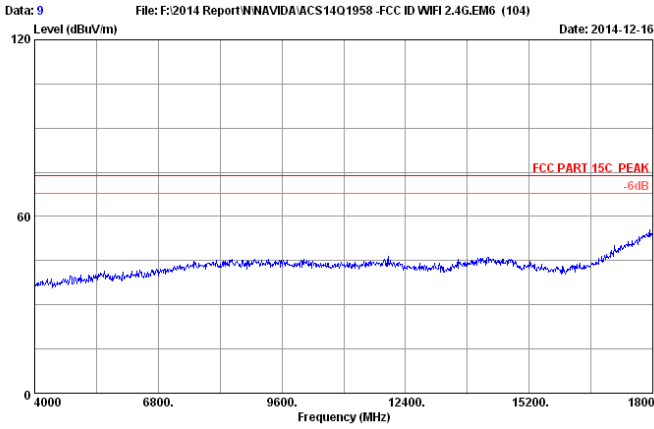

Site no. : 3m Chamber Data no. : 9  
 Dis. / Ant. : 3m 2014 3115 (4580) Ant. pol. : HORIZONTAL  
 Limit : FCC PART 15C PEAK  
 Env. / Ins. : 23°C/54%  
 Engineer : Kobe-Huang  
 EUT : Complex Set-Top Box  
 Power rating : DC 19V From Adpater Input AC 120V/60Hz  
 Test Mode : IEEE802.11g 2412MHz Tx Mode  
 M/N : P2571

Site no. : 3m Chamber Data no. : 7  
 Dis. / Ant. : 3m 2014 3115 (4580) Ant. pol. : VERTICAL  
 Limit : FCC PART 15C PEAK  
 Env. / Ins. : 23°C/54%  
 Engineer : Kobe-Huang  
 EUT : Complex Set-Top Box  
 Power rating : DC 19V From Adpater Input AC 120V/60Hz  
 Test Mode : IEEE802.11g 2412MHz Tx Mode  
 M/N : P2571

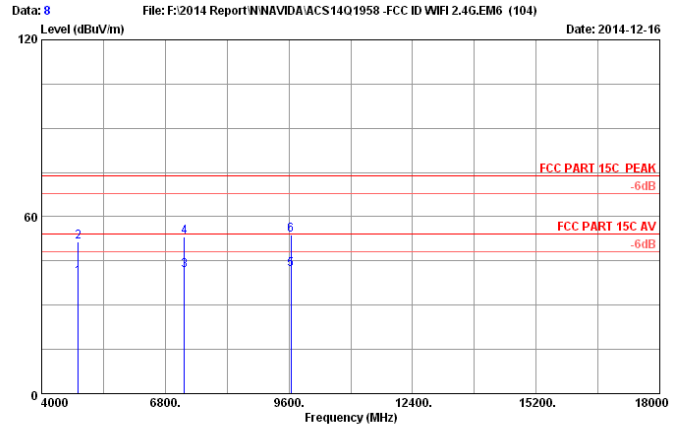
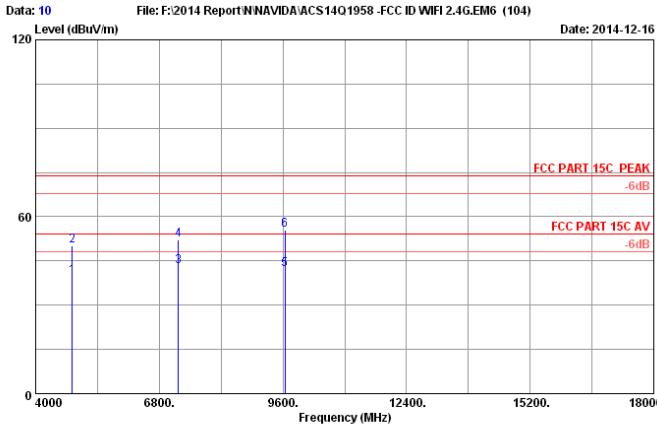

Site no. : 3m Chamber Data no. : 10  
 Dis. / Ant. : 3m 2014 3115 (4580) Ant. pol. : HORIZONTAL  
 Limit : FCC PART 15C PEAK  
 Env. / Ins. : 23°C/54%  
 Engineer : Kobe-Huang  
 EUT : Complex Set-Top Box  
 Power rating : DC 19V From Adpater Input AC 120V/60Hz  
 Test Mode : IEEE802.11g 2412MHz Tx Mode  
 M/N : P2571

Site no. : 3m Chamber Data no. : 8  
 Dis. / Ant. : 3m 2014 3115 (4580) Ant. pol. : VERTICAL  
 Limit : FCC PART 15C PEAK  
 Env. / Ins. : 23°C/54%  
 Engineer : Kobe-Huang  
 EUT : Complex Set-Top Box  
 Power rating : DC 19V From Adpater Input AC 120V/60Hz  
 Test Mode : IEEE802.11g 2412MHz Tx Mode  
 M/N : P2571

No.	Freq. (MHz)	Ant. Factor (dB/m)	Cable Loss (dB)	AMP factor (dB)	Reading (dBuV)	Emission Level (dBuV/m)	Limits (dBuV/m)	Margin (dB)	Remark
1	4824.000	32.88	8.58	35.70	33.85	39.61	54.00	14.39	Average
2	4824.000	32.88	8.58	35.70	44.49	50.25	74.00	23.75	Peak
3	7236.000	36.02	10.98	35.45	31.68	43.23	54.00	10.77	Average
4	7236.000	36.02	10.98	35.45	40.69	52.24	74.00	21.76	Peak
5	9648.000	37.79	12.25	35.46	27.57	42.15	54.00	11.85	Average
6	9648.000	37.79	12.25	35.46	40.75	55.33	74.00	18.67	Peak

No.	Freq. (MHz)	Ant. Factor (dB/m)	Cable Loss (dB)	AMP factor (dB)	Reading (dBuV)	Emission Level (dBuV/m)	Limits (dBuV/m)	Margin (dB)	Remark
1	4824.000	32.88	8.58	35.70	33.69	39.45	54.00	14.55	Average
2	4824.000	32.88	8.58	35.70	45.84	51.60	74.00	22.40	Peak
3	7236.000	36.02	10.98	35.45	30.12	41.67	54.00	12.33	Average
4	7236.000	36.02	10.98	35.45	41.66	53.21	74.00	20.79	Peak
5	9648.000	37.79	12.25	35.46	27.68	42.26	54.00	11.74	Average
6	9648.000	37.79	12.25	35.46	39.34	53.92	74.00	20.08	Peak

Remarks: 1. Emission Level= Antenna Factor + Cable Loss + Reading - Amp Factor  
 2. The emission levels that are 20dB below the official limit are not reported.

Remarks: 1. Emission Level= Antenna Factor + Cable Loss + Reading - Amp Factor  
 2. The emission levels that are 20dB below the official limit are not reported.

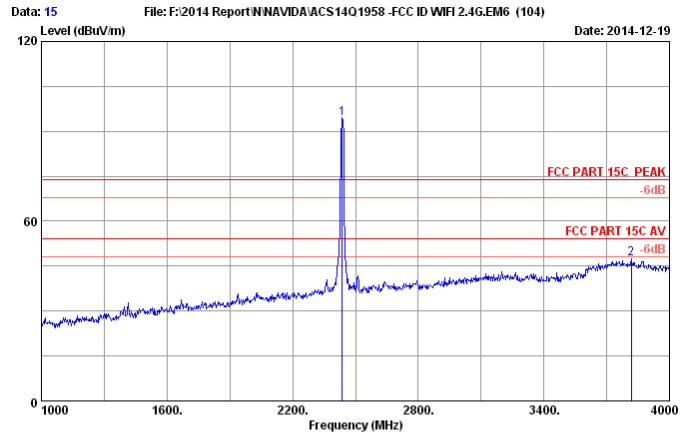
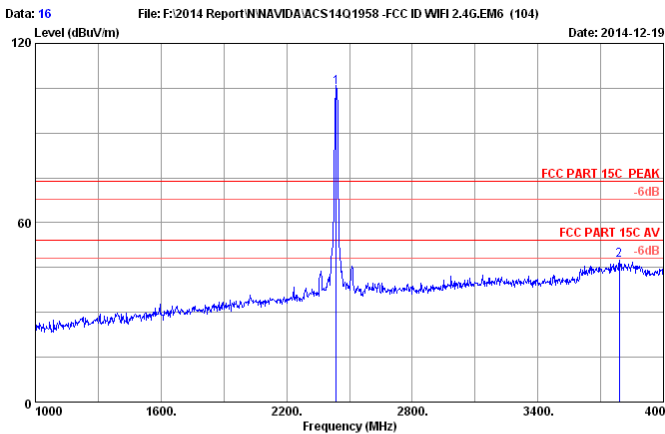

Site no. : 3m Chamber Data no. : 16  
 Dis. / Ant. : 3m 2014 3115 (4580) Ant. pol. : HORIZONTAL  
 Limit : FCC PART 15C PEAK  
 Env. / Ins. : 23°C/54%  
 Engineer : Kobe-Huang  
 EUT : Complex Set-Top Box  
 Power rating : DC 19V From Adpater Input AC 120V/60Hz  
 Test Mode : IEEE802.11g 2437MHz Tx Mode  
 M/N : P2571

Site no. : 3m Chamber Data no. : 15  
 Dis. / Ant. : 3m 2014 3115 (4580) Ant. pol. : VERTICAL  
 Limit : FCC PART 15C PEAK  
 Env. / Ins. : 23°C/54%  
 Engineer : Kobe-Huang  
 EUT : Complex Set-Top Box  
 Power rating : DC 19V From Adpater Input AC 120V/60Hz  
 Test Mode : IEEE802.11g 2437MHz Tx Mode  
 M/N : P2571

No.	Freq. (MHz)	Ant. Factor (dB/m)	Cable Loss (dB)	AMP factor (dB)	Reading (dBuV)	Emission Level (dBuV/m)	Limits (dBuV/m)	Margin (dB)	Remark
1	2437.000	28.26	5.85	35.70	106.94	105.35	74.00	-31.35	Peak
2	3790.000	32.10	7.50	35.70	43.69	47.59	74.00	26.41	Peak

No.	Freq. (MHz)	Ant. Factor (dB/m)	Cable Loss (dB)	AMP factor (dB)	Reading (dBuV)	Emission Level (dBuV/m)	Limits (dBuV/m)	Margin (dB)	Remark
1	2437.000	28.26	5.85	35.70	95.78	94.19	74.00	-20.19	Peak
2	3817.000	32.16	7.53	35.70	43.51	47.50	74.00	26.50	Peak

Remarks: 1. Emission Level= Antenna Factor + Cable Loss + Reading - Amp Factor  
 2. The emission levels that are 20dB below the official limit are not reported.

Remarks: 1. Emission Level= Antenna Factor + Cable Loss + Reading - Amp Factor  
 2. The emission levels that are 20dB below the official limit are not reported.



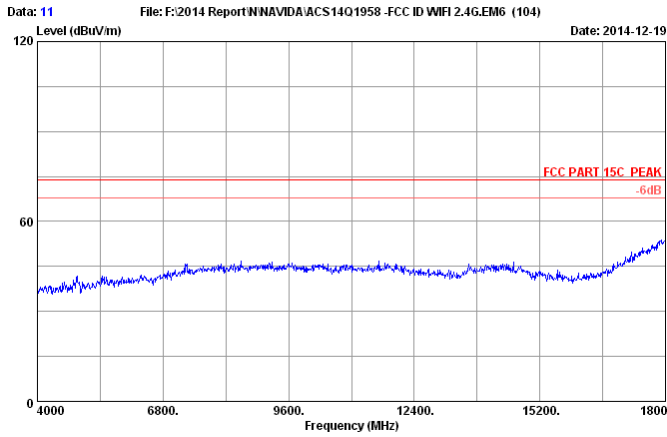

Site no. : 3m Chamber Data no. : 11  
 Dis. / Ant. : 3m 2014 3115 (4580) Ant. pol. : HORIZONTAL  
 Limit : FCC PART 15C PEAK  
 Env. / Ins. : 23°C/54%  
 Engineer : Kobe-Huang  
 EUT : Complex Set-Top Box  
 Power rating : DC 19V From Adppter Input AC 120V/60Hz  
 Test Mode : IEEE802.11g 2437MHz Tx Mode  
 M/N : P2571

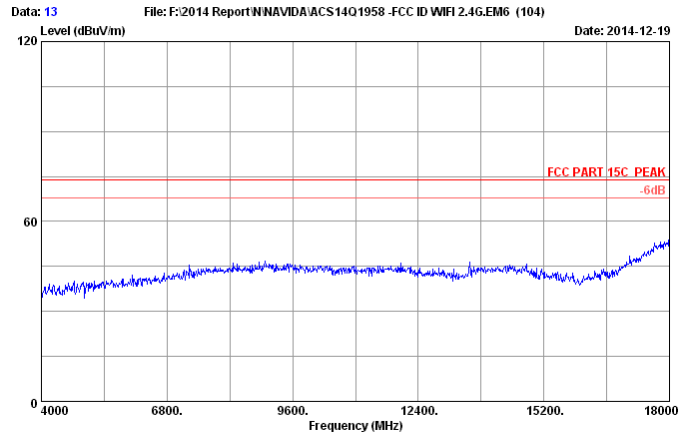

Site no. : 3m Chamber Data no. : 13  
 Dis. / Ant. : 3m 2014 3115 (4580) Ant. pol. : VERTICAL  
 Limit : FCC PART 15C PEAK  
 Env. / Ins. : 23°C/54%  
 Engineer : Kobe-Huang  
 EUT : Complex Set-Top Box  
 Power rating : DC 19V From Adppter Input AC 120V/60Hz  
 Test Mode : IEEE802.11g 2437MHz Tx Mode  
 M/N : P2571

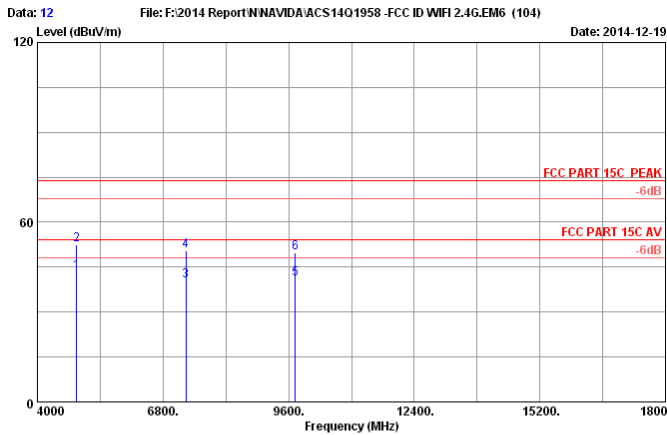

Site no. : 3m Chamber Data no. : 12  
 Dis. / Ant. : 3m 2014 3115 (4580) Ant. pol. : HORIZONTAL  
 Limit : FCC PART 15C PEAK  
 Env. / Ins. : 23°C/54%  
 Engineer : Kobe-Huang  
 EUT : Complex Set-Top Box  
 Power rating : DC 19V From Adppter Input AC 120V/60Hz  
 Test Mode : IEEE802.11g 2437MHz Tx Mode  
 M/N : P2571

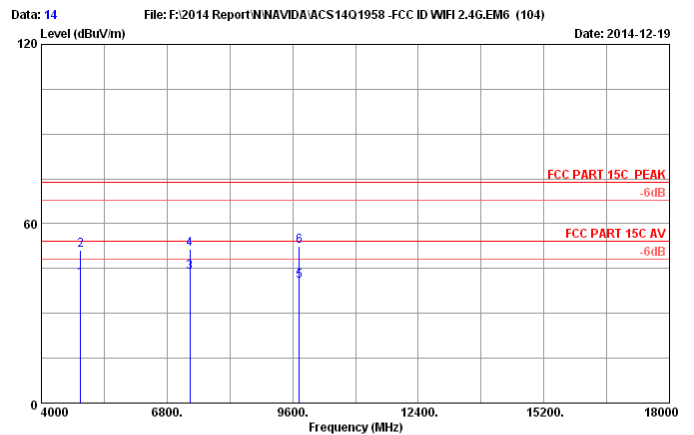

Site no. : 3m Chamber Data no. : 14  
 Dis. / Ant. : 3m 2014 3115 (4580) Ant. pol. : VERTICAL  
 Limit : FCC PART 15C PEAK  
 Env. / Ins. : 23°C/54%  
 Engineer : Kobe-Huang  
 EUT : Complex Set-Top Box  
 Power rating : DC 19V From Adppter Input AC 120V/60Hz  
 Test Mode : IEEE802.11g 2437MHz Tx Mode  
 M/N : P2571

No.	Freq. (MHz)	Ant. Factor (dB/m)	Cable Loss (dB)	AMP factor (dB)	Reading (dBuV)	Emission Level (dBuV/m)	Limits (dBuV/m)	Margin (dB)	Remark
1	4874.000	32.97	8.63	35.70	37.59	43.49	54.00	10.51	Average
2	4874.000	32.97	8.63	35.70	46.43	52.33	74.00	21.67	Peak
3	7311.000	36.18	11.02	35.44	28.79	40.55	54.00	13.45	Average
4	7311.000	36.18	11.02	35.44	38.59	50.35	74.00	23.65	Peak
5	9748.000	37.85	12.30	35.47	26.46	41.14	54.00	12.86	Average
6	9748.000	37.85	12.30	35.47	34.98	49.66	74.00	24.34	Peak

Remarks: 1. Emission Level= Antenna Factor + Cable Loss + Reading - Amp Factor  
 2. The emission levels that are 20dB below the official limit are not reported.

No.	Freq. (MHz)	Ant. Factor (dB/m)	Cable Loss (dB)	AMP factor (dB)	Reading (dBuV)	Emission Level (dBuV/m)	Limits (dBuV/m)	Margin (dB)	Remark
1	4874.000	32.97	8.63	35.70	35.67	41.57	54.00	12.43	Average
2	4874.000	32.97	8.63	35.70	45.40	51.30	74.00	22.70	Peak
3	7311.000	36.18	11.02	35.44	31.88	43.64	54.00	10.36	Average
4	7311.000	36.18	11.02	35.44	39.87	51.63	74.00	22.37	Peak
5	9748.000	37.85	12.30	35.47	26.26	40.94	54.00	13.06	Average
6	9748.000	37.85	12.30	35.47	37.68	52.36	74.00	21.64	Peak

Remarks: 1. Emission Level= Antenna Factor + Cable Loss + Reading - Amp Factor  
 2. The emission levels that are 20dB below the official limit are not reported.

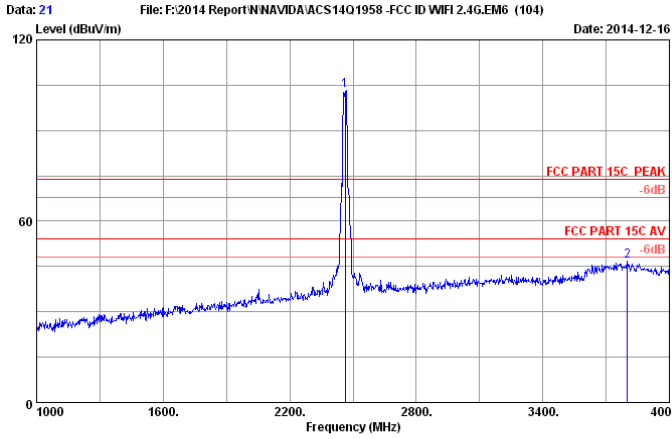

Site no. : 3m Chamber Data no. : 21  
 Dis. / Ant. : 3m 2014 3115 (4580) Ant. pol. : HORIZONTAL  
 Limit : FCC PART 15C PEAK  
 Env. / Ins. : 23°C/54%  
 Engineer : Kobe-Huang  
 EUT : Complex Set-Top Box  
 Power rating : DC 19V From Adppter Input AC 120V/60Hz  
 Test Mode : IEEE802.11g 2462MHz Tx Mode  
 M/N : P2571

No.	Freq. (MHz)	Ant. Factor (dB/m)	Cable Loss (dB)	AMP factor (dB)	Reading (dBuV)	Emission Level (dBuV/m)	Limits (dBuV/m)	Margin (dB)	Remark
1	2462.000	28.32	5.89	35.70	104.77	103.28	74.00	-29.28	Peak
2	3802.000	32.12	7.51	35.70	43.01	46.94	74.00	27.06	Peak

Remarks: 1. Emission Level= Antenna Factor + Cable Loss + Reading - Amp Factor  
 2. The emission levels that are 20dB below the official limit are not reported.

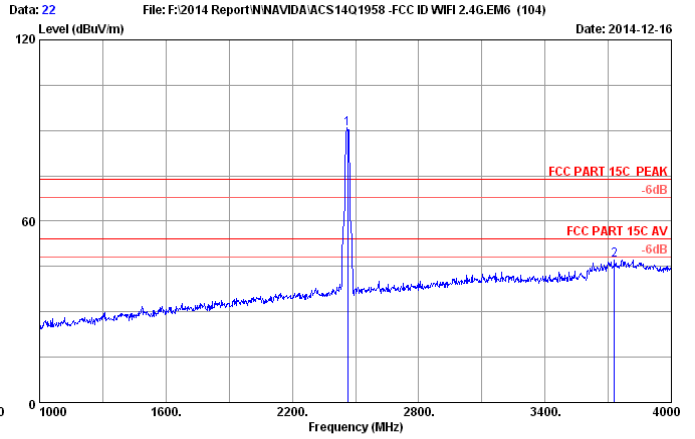

Site no. : 3m Chamber Data no. : 22  
 Dis. / Ant. : 3m 2014 3115 (4580) Ant. pol. : VERTICAL  
 Limit : FCC PART 15C PEAK  
 Env. / Ins. : 23°C/54%  
 Engineer : Kobe-Huang  
 EUT : Complex Set-Top Box  
 Power rating : DC 19V From Adppter Input AC 120V/60Hz  
 Test Mode : IEEE802.11g 2462MHz Tx Mode  
 M/N : P2571

No.	Freq. (MHz)	Ant. Factor (dB/m)	Cable Loss (dB)	AMP factor (dB)	Reading (dBuV)	Emission Level (dBuV/m)	Limits (dBuV/m)	Margin (dB)	Remark
1	2462.000	28.32	5.89	35.70	92.06	90.57	74.00	-16.57	Peak
2	3730.000	31.95	7.43	35.70	43.47	47.15	74.00	26.85	Peak

Remarks: 1. Emission Level= Antenna Factor + Cable Loss + Reading - Amp Factor  
 2. The emission levels that are 20dB below the official limit are not reported.

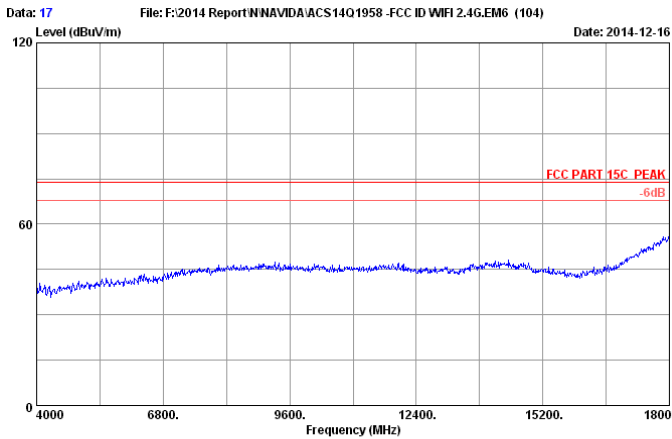

Site no. : 3m Chamber Data no. : 17  
 Dis. / Ant. : 3m 2014 3115 (4580) Ant. pol. : HORIZONTAL  
 Limit : FCC PART 15C PEAK  
 Env. / Ins. : 23°C/54%  
 Engineer : Kobe-Huang  
 EUT : Complex Set-Top Box  
 Power rating : DC 19V From Adppter Input AC 120V/60Hz  
 Test Mode : IEEE802.11g 2462MHz Tx Mode  
 M/N : P2571

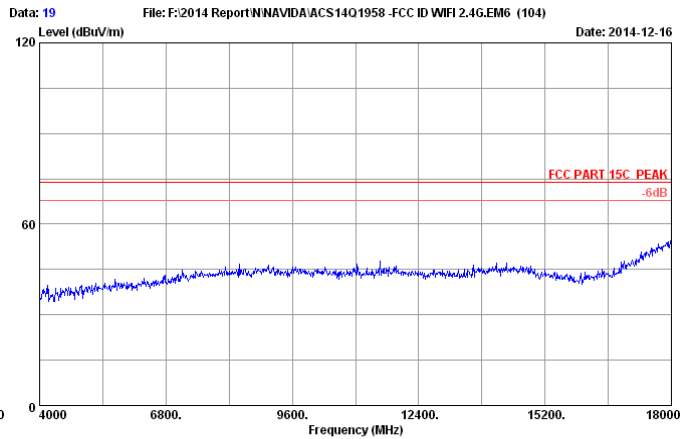

Site no. : 3m Chamber Data no. : 19  
 Dis. / Ant. : 3m 2014 3115 (4580) Ant. pol. : VERTICAL  
 Limit : FCC PART 15C PEAK  
 Env. / Ins. : 23°C/54%  
 Engineer : Kobe-Huang  
 EUT : Complex Set-Top Box  
 Power rating : DC 19V From Adppter Input AC 120V/60Hz  
 Test Mode : IEEE802.11g 2462MHz Tx Mode  
 M/N : P2571

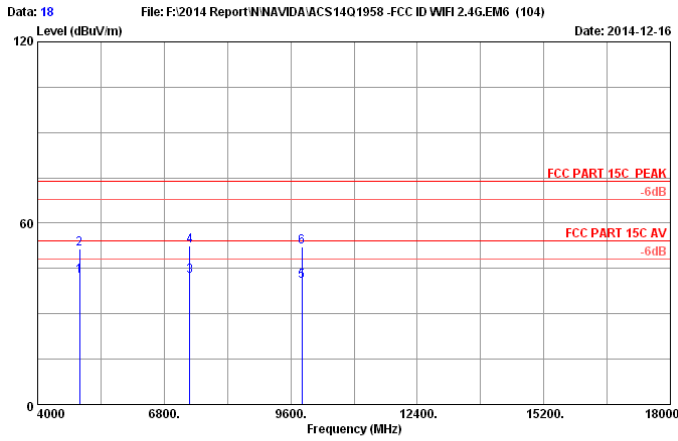

Site no. : 3m Chamber Data no. : 18  
 Dis. / Ant. : 3m 2014 3115 (4580) Ant. pol. : HORIZONTAL  
 Limit : FCC PART 15C PEAK  
 Env. / Ins. : 23°C/54%  
 Engineer : Kobe-Huang  
 EUT : Complex Set-Top Box  
 Power rating : DC 19V From Adpater Input AC 120V/60Hz  
 Test Mode : IEEE802.11g 2462MHz Tx Mode  
 M/N : P2571

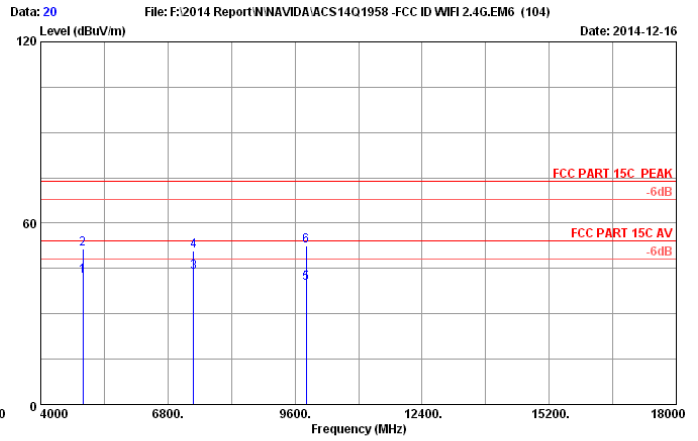

Site no. : 3m Chamber Data no. : 20  
 Dis. / Ant. : 3m 2014 3115 (4580) Ant. pol. : VERTICAL  
 Limit : FCC PART 15C PEAK  
 Env. / Ins. : 23°C/54%  
 Engineer : Kobe-Huang  
 EUT : Complex Set-Top Box  
 Power rating : DC 19V From Adpater Input AC 120V/60Hz  
 Test Mode : IEEE802.11g 2462MHz Tx Mode  
 M/N : P2571

No.	Freq. (MHz)	Ant. Factor (dB/m)	Cable Loss (dB)	AMP factor (dB)	Reading (dBuV)	Emission Level (dBuV/m)	Limits (dBuV/m)	Margin (dB)	Remark
1	4924.000	33.06	8.69	35.70	36.36	42.41	54.00	11.59	Average
2	4924.000	33.06	8.69	35.70	45.51	51.56	74.00	22.44	Peak
3	7368.000	36.31	11.05	35.43	30.58	42.51	54.00	11.49	Average
4	7368.000	36.31	11.05	35.43	40.40	52.33	74.00	21.67	Peak
5	9848.000	37.91	12.35	35.48	25.83	40.61	54.00	13.39	Average
6	9848.000	37.91	12.35	35.48	37.35	52.13	74.00	21.87	Peak

Remarks: 1. Emission Level= Antenna Factor + Cable Loss + Reading - Amp Factor  
 2. The emission levels that are 20dB below the official limit are not reported.

No.	Freq. (MHz)	Ant. Factor (dB/m)	Cable Loss (dB)	AMP factor (dB)	Reading (dBuV)	Emission Level (dBuV/m)	Limits (dBuV/m)	Margin (dB)	Remark
1	4924.000	33.06	8.69	35.70	36.39	42.44	54.00	11.56	Average
2	4924.000	33.06	8.69	35.70	45.57	51.62	74.00	22.38	Peak
3	7368.000	36.31	11.05	35.43	31.70	43.63	54.00	10.37	Average
4	7368.000	36.31	11.05	35.43	38.99	50.92	74.00	23.08	Peak
5	9848.000	37.91	12.35	35.48	25.46	40.24	54.00	13.76	Average
6	9848.000	37.91	12.35	35.48	37.68	52.46	74.00	21.54	Peak

Remarks: 1. Emission Level= Antenna Factor + Cable Loss + Reading - Amp Factor  
 2. The emission levels that are 20dB below the official limit are not reported.

### Test Mode: IEEE 802.11n HT20

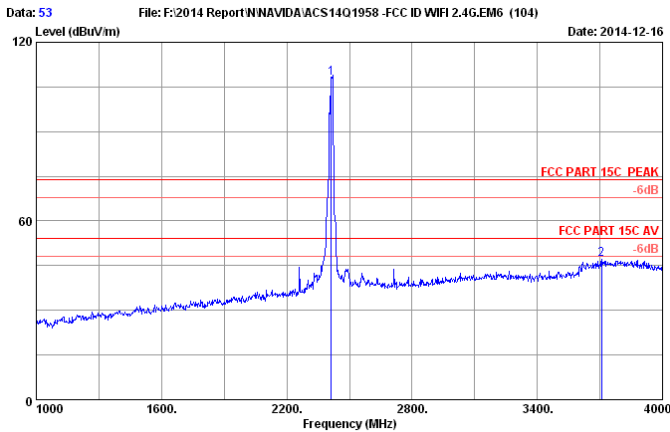

Site no. : 3m Chamber Data no. : 53  
 Dis. / Ant. : 3m 2014 3115 (4580) Ant. pol. : HORIZONTAL  
 Limit : FCC PART 15C PEAK  
 Env. / Ins. : 23°C/54%  
 Engineer : Kobe-Huang  
 EUT : Complex Set-Top Box  
 Power rating : DC 19V From Adpater Input AC 120V/60Hz  
 Test Mode : IEEE802.11nHT20 2412MHz Tx Mode  
 M/N : P2571

No.	Freq. (MHz)	Ant. Factor (dB/m)	Cable Loss (dB)	AMP factor (dB)	Reading (dBuV)	Emission Level (dBuV/m)	Limits (dBuV/m)	Margin (dB)	Remark
1	2412.000	28.21	5.81	35.70	109.68	108.00	74.00	-34.00	Peak
2	3709.000	31.90	7.41	35.70	43.39	47.00	74.00	27.00	Peak

Remarks: 1. Emission Level= Antenna Factor + Cable Loss + Reading - Amp Factor  
 2. The emission levels that are 20dB below the official limit are not reported.

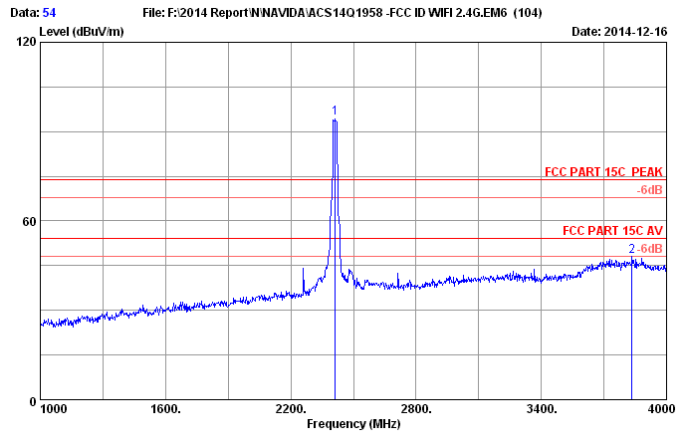

Site no. : 3m Chamber Data no. : 54  
 Dis. / Ant. : 3m 2014 3115 (4580) Ant. pol. : VERTICAL  
 Limit : FCC PART 15C PEAK  
 Env. / Ins. : 23°C/54%  
 Engineer : Kobe-Huang  
 EUT : Complex Set-Top Box  
 Power rating : DC 19V From Adpater Input AC 120V/60Hz  
 Test Mode : IEEE802.11nHT20 2412MHz Tx Mode  
 M/N : P2571

No.	Freq. (MHz)	Ant. Factor (dB/m)	Cable Loss (dB)	AMP factor (dB)	Reading (dBuV)	Emission Level (dBuV/m)	Limits (dBuV/m)	Margin (dB)	Remark
1	2412.000	28.21	5.81	35.70	96.33	94.65	74.00	-20.65	Peak
2	3835.000	32.20	7.54	35.70	44.12	48.16	74.00	25.84	Peak

Remarks: 1. Emission Level= Antenna Factor + Cable Loss + Reading - Amp Factor  
 2. The emission levels that are 20dB below the official limit are not reported.

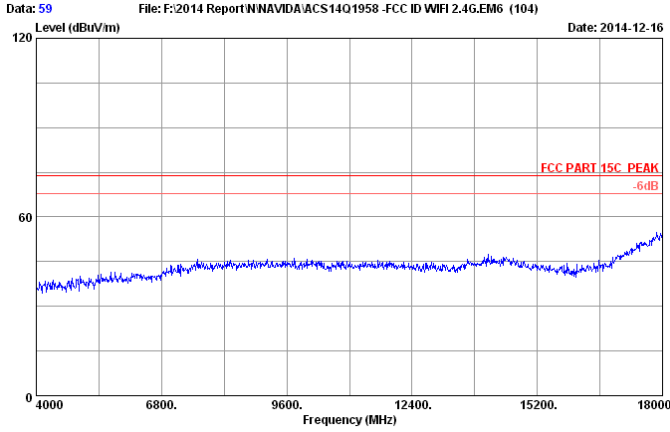

Site no. : 3m Chamber Data no. : 59  
 Dis. / Ant. : 3m 2014 3115 (4580) Ant. pol. : HORIZONTAL  
 Limit : FCC PART 15C PEAK  
 Env. / Ins. : 23°C/54%  
 Engineer : Kobe-Huang  
 EUT : Complex Set-Top Box  
 Power rating : DC 19V From Adppter Input AC 120V/60Hz  
 Test Mode : IEEE802.11nHT20 2412MHz Tx Mode  
 M/N : P2571

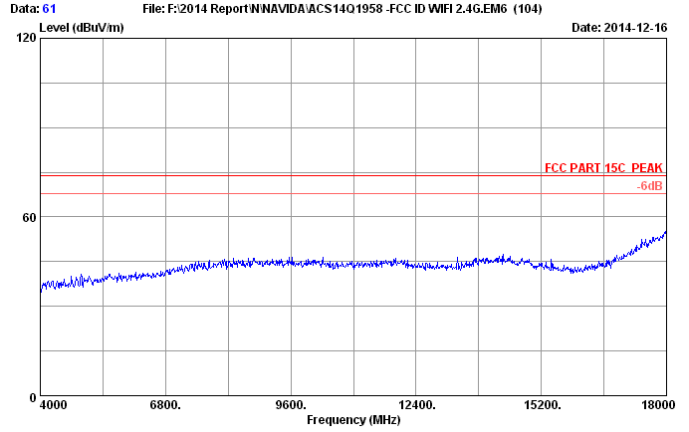

Site no. : 3m Chamber Data no. : 61  
 Dis. / Ant. : 3m 2014 3115 (4580) Ant. pol. : VERTICAL  
 Limit : FCC PART 15C PEAK  
 Env. / Ins. : 23°C/54%  
 Engineer : Kobe-Huang  
 EUT : Complex Set-Top Box  
 Power rating : DC 19V From Adppter Input AC 120V/60Hz  
 Test Mode : IEEE802.11nHT20 2412MHz Tx Mode  
 M/N : P2571

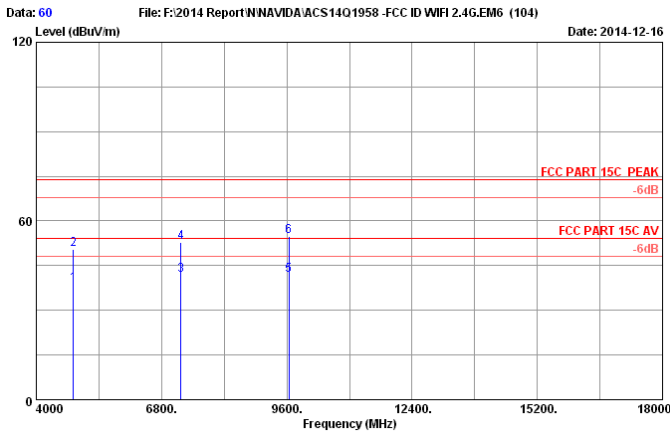

Site no. : 3m Chamber Data no. : 60  
 Dis. / Ant. : 3m 2014 3115 (4580) Ant. pol. : HORIZONTAL  
 Limit : FCC PART 15C PEAK  
 Env. / Ins. : 23°C/54%  
 Engineer : Kobe-Huang  
 EUT : Complex Set-Top Box  
 Power rating : DC 19V From Adppter Input AC 120V/60Hz  
 Test Mode : IEEE802.11nHT20 2412MHz Tx Mode  
 M/N : P2571

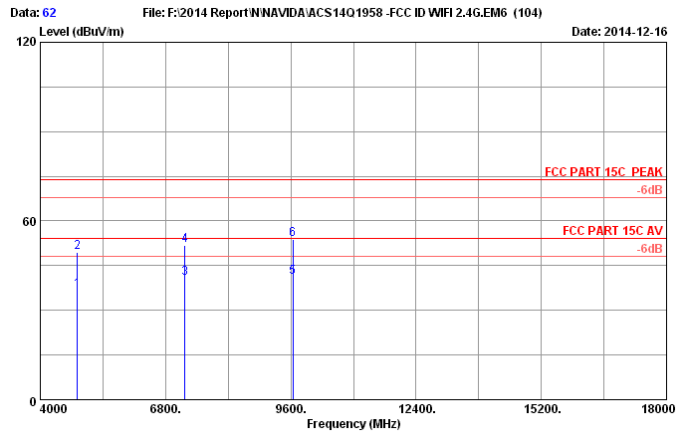

Site no. : 3m Chamber Data no. : 62  
 Dis. / Ant. : 3m 2014 3115 (4580) Ant. pol. : VERTICAL  
 Limit : FCC PART 15C PEAK  
 Env. / Ins. : 23°C/54%  
 Engineer : Kobe-Huang  
 EUT : Complex Set-Top Box  
 Power rating : DC 19V From Adppter Input AC 120V/60Hz  
 Test Mode : IEEE802.11nHT20 2412MHz Tx Mode  
 M/N : P2571

No.	Freq. (MHz)	Ant. Factor (dB/m)	Cable Loss (dB)	AMP factor (dB)	Reading (dBuV)	Emission Level (dBuV/m)	Limits (dBuV/m)	Margin (dB)	Remark
1	4824.000	32.88	8.58	35.70	33.12	38.88	54.00	15.12	Average
2	4824.000	32.88	8.58	35.70	44.69	50.45	74.00	23.55	Peak
3	7236.000	36.02	10.98	35.45	30.25	41.80	54.00	12.20	Average
4	7236.000	36.02	10.98	35.45	41.16	52.71	74.00	21.29	Peak
5	9648.000	37.79	12.25	35.46	27.23	41.81	54.00	12.19	Average
6	9648.000	37.79	12.25	35.46	40.10	54.68	74.00	19.32	Peak

Remarks: 1. Emission Level= Antenna Factor + Cable Loss + Reading -amp Factor  
 2. The emission levels that are 20dB below the official limit are not reported.

No.	Freq. (MHz)	Ant. Factor (dB/m)	Cable Loss (dB)	AMP factor (dB)	Reading (dBuV)	Emission Level (dBuV/m)	Limits (dBuV/m)	Margin (dB)	Remark
1	4824.000	32.88	8.58	35.70	31.11	36.87	54.00	17.13	Average
2	4824.000	32.88	8.58	35.70	43.57	49.33	74.00	24.67	Peak
3	7236.000	36.02	10.98	35.45	29.37	40.92	54.00	13.08	Average
4	7236.000	36.02	10.98	35.45	40.37	51.92	74.00	22.08	Peak
5	9648.000	37.79	12.25	35.46	26.57	41.15	54.00	12.85	Average
6	9648.000	37.79	12.25	35.46	39.36	53.94	74.00	20.06	Peak

Remarks: 1. Emission Level= Antenna Factor + Cable Loss + Reading -amp Factor  
 2. The emission levels that are 20dB below the official limit are not reported.

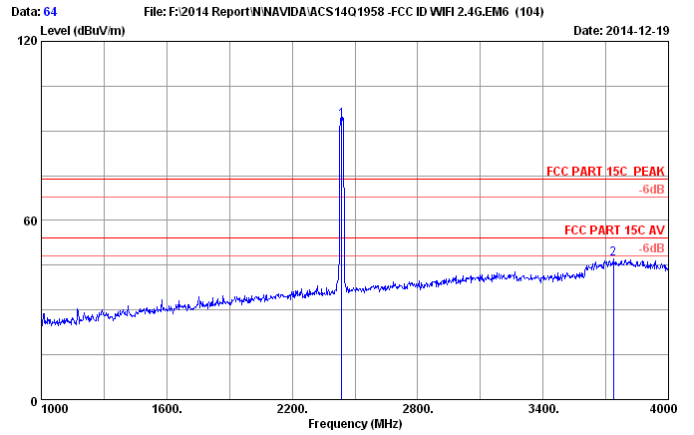
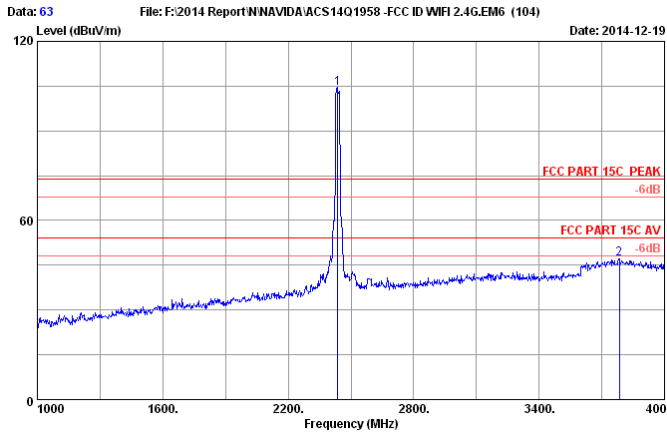

Site no. : 3m Chamber Data no. : 63  
 Dis. / Ant. : 3m 2014 3115 (4580) Ant. pol. : HORIZONTAL  
 Limit : FCC PART 15C PEAK  
 Env. / Ins. : 23°C/54%  
 Engineer : Kobe-Huang  
 EUT : Complex Set-Top Box  
 Power rating : DC 19V From Adppter Input AC 120V/60Hz  
 Test Mode : IEEE802.11nHT20 2437MHz Tx Mode  
 M/N : P2571

Site no. : 3m Chamber Data no. : 64  
 Dis. / Ant. : 3m 2014 3115 (4580) Ant. pol. : VERTICAL  
 Limit : FCC PART 15C PEAK  
 Env. / Ins. : 23°C/54%  
 Engineer : Kobe-Huang  
 EUT : Complex Set-Top Box  
 Power rating : DC 19V From Adppter Input AC 120V/60Hz  
 Test Mode : IEEE802.11nHT20 2437MHz Tx Mode  
 M/N : P2571

No.	Freq. (MHz)	Ant. Factor (dB/m)	Cable Loss (dB)	AMP factor (dB)	Reading (dBuV)	Emission Level (dBuV/m)	Limits (dBuV/m)	Margin (dB)	Remark
1	2437.000	28.26	5.85	35.70	105.80	104.21	74.00	-30.21	Peak
2	3784.000	32.08	7.49	35.70	43.38	47.25	74.00	26.75	Peak

No.	Freq. (MHz)	Ant. Factor (dB/m)	Cable Loss (dB)	AMP factor (dB)	Reading (dBuV)	Emission Level (dBuV/m)	Limits (dBuV/m)	Margin (dB)	Remark
1	2437.000	28.26	5.85	35.70	95.31	93.72	74.00	-19.72	Peak
2	3736.000	31.97	7.44	35.70	43.56	47.27	74.00	26.73	Peak

Remarks: 1. Emission Level= Antenna Factor + Cable Loss + Reading -Amp Factor  
 2. The emission levels that are 20dB below the official limit are not reported.

Remarks: 1. Emission Level= Antenna Factor + Cable Loss + Reading -Amp Factor  
 2. The emission levels that are 20dB below the official limit are not reported.

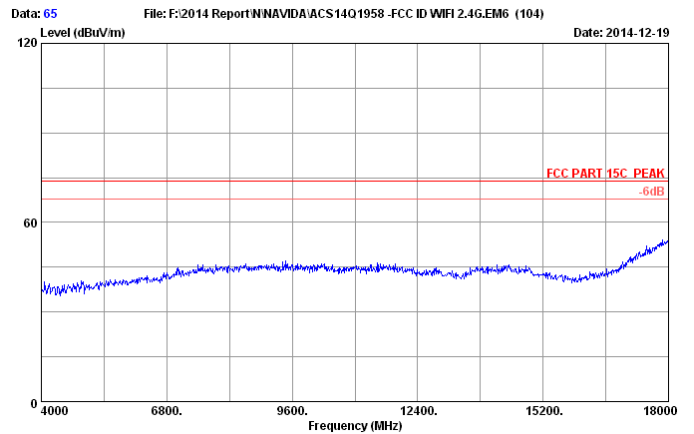
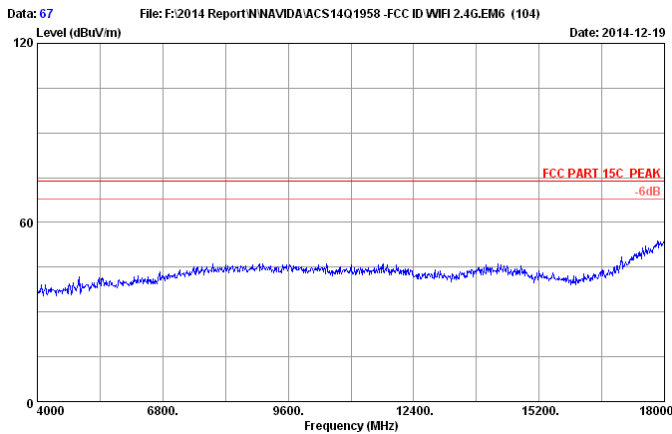

Site no. : 3m Chamber Data no. : 67  
 Dis. / Ant. : 3m 2014 3115 (4580) Ant. pol. : HORIZONTAL  
 Limit : FCC PART 15C PEAK  
 Env. / Ins. : 23°C/54%  
 Engineer : Kobe-Huang  
 EUT : Complex Set-Top Box  
 Power rating : DC 19V From Adppter Input AC 120V/60Hz  
 Test Mode : IEEE802.11nHT20 2437MHz Tx Mode  
 M/N : P2571

Site no. : 3m Chamber Data no. : 65  
 Dis. / Ant. : 3m 2014 3115 (4580) Ant. pol. : VERTICAL  
 Limit : FCC PART 15C PEAK  
 Env. / Ins. : 23°C/54%  
 Engineer : Kobe-Huang  
 EUT : Complex Set-Top Box  
 Power rating : DC 19V From Adppter Input AC 120V/60Hz  
 Test Mode : IEEE802.11nHT20 2437MHz Tx Mode  
 M/N : P2571

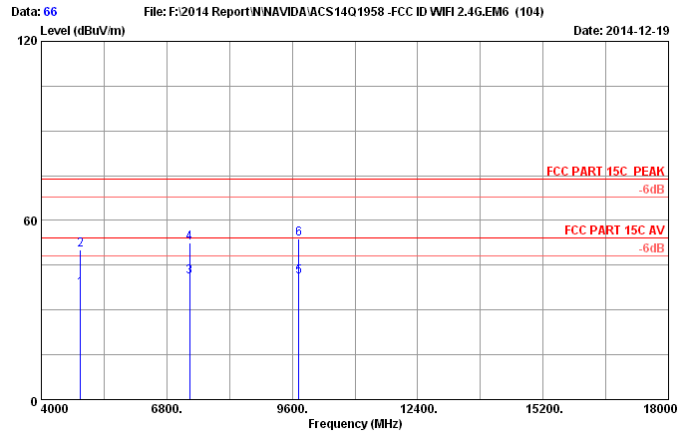
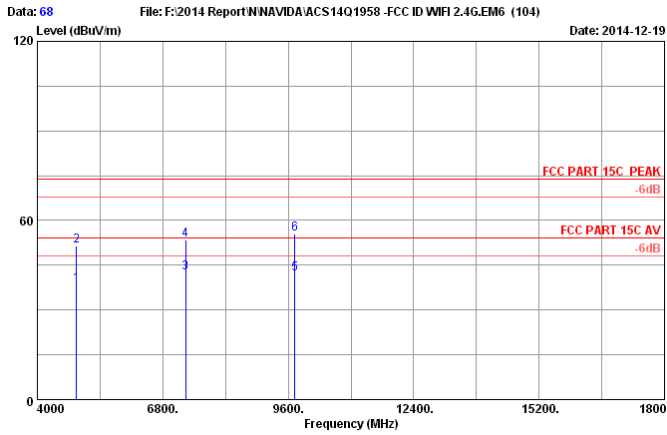

Site no. : 3m Chamber Data no. : 68  
 Dis. / Ant. : 3m 2014 3115 (4580) Ant. pol. : HORIZONTAL  
 Limit : FCC PART 15C PEAK  
 Env. / Ins. : 23°C/54%  
 Engineer : Kobe-Huang  
 EUT : Complex Set-Top Box  
 Power rating : DC 19V From Adppter Input AC 120V/60Hz  
 Test Mode : IEEE802.11nHT20 2437MHz Tx Mode  
 M/N : P2571

Site no. : 3m Chamber Data no. : 66  
 Dis. / Ant. : 3m 2014 3115 (4580) Ant. pol. : VERTICAL  
 Limit : FCC PART 15C PEAK  
 Env. / Ins. : 23°C/54%  
 Engineer : Kobe-Huang  
 EUT : Complex Set-Top Box  
 Power rating : DC 19V From Adppter Input AC 120V/60Hz  
 Test Mode : IEEE802.11nHT20 2437MHz Tx Mode  
 M/N : P2571

No.	Freq. (MHz)	Ant. Factor (dB/m)	Cable Loss (dB)	AMP factor (dB)	Reading (dBuV)	Emission Level (dBuV/m)	Limits (dBuV/m)	Margin (dB)	Remark
1	4874.000	32.97	8.63	35.70	32.58	38.48	54.00	15.52	Average
2	4874.000	32.97	8.63	35.70	45.70	51.60	74.00	22.40	Peak
3	7311.000	36.18	11.02	35.44	30.70	42.46	54.00	11.54	Average
4	7311.000	36.18	11.02	35.44	41.78	53.54	74.00	20.46	Peak
5	9748.000	37.85	12.30	35.47	27.55	42.23	54.00	11.77	Average
6	9748.000	37.85	12.30	35.47	40.72	55.40	74.00	18.60	Peak

No.	Freq. (MHz)	Ant. Factor (dB/m)	Cable Loss (dB)	AMP factor (dB)	Reading (dBuV)	Emission Level (dBuV/m)	Limits (dBuV/m)	Margin (dB)	Remark
1	4874.000	32.97	8.63	35.70	31.23	37.13	54.00	16.87	Average
2	4874.000	32.97	8.63	35.70	44.22	50.12	74.00	23.88	Peak
3	7311.000	36.18	11.02	35.44	29.36	41.12	54.00	12.88	Average
4	7311.000	36.18	11.02	35.44	40.59	52.35	74.00	21.65	Peak
5	9748.000	37.85	12.30	35.47	26.48	41.16	54.00	12.84	Average
6	9748.000	37.85	12.30	35.47	39.25	53.93	74.00	20.07	Peak

Remarks: 1. Emission Level= Antenna Factor + Cable Loss + Reading -Amp Factor  
 2. The emission levels that are 20dB below the official limit are not reported.

Remarks: 1. Emission Level= Antenna Factor + Cable Loss + Reading -Amp Factor  
 2. The emission levels that are 20dB below the official limit are not reported.

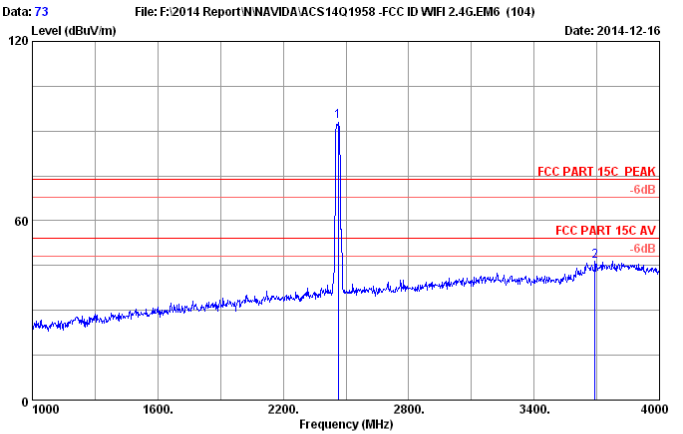
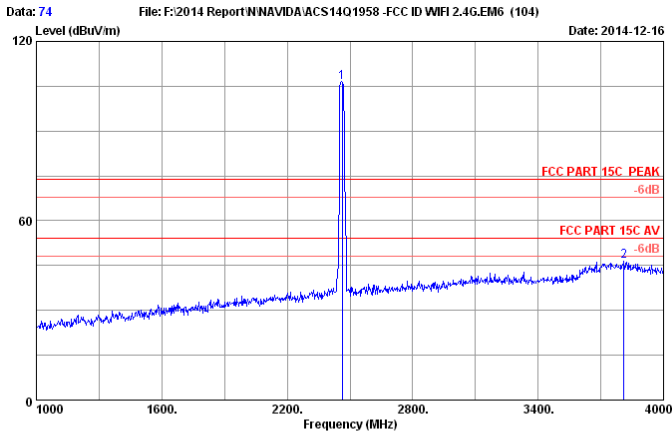

Site no. : 3m Chamber Data no. : 74  
 Dis. / Ant. : 3m 2014 3115 (4580) Ant. pol. : HORIZONTAL  
 Limit : FCC PART 15C PEAK  
 Env. / Ins. : 23°C/54%  
 Engineer : Kobe-Huang  
 EUT : Complex Set-Top Box  
 Power rating : DC 19V From Adppter Input AC 120V/60Hz  
 Test Mode : IEEE802.11nHT20 2462MHz Tx Mode  
 M/N : P2571

Site no. : 3m Chamber Data no. : 73  
 Dis. / Ant. : 3m 2014 3115 (4580) Ant. pol. : VERTICAL  
 Limit : FCC PART 15C PEAK  
 Env. / Ins. : 23°C/54%  
 Engineer : Kobe-Huang  
 EUT : Complex Set-Top Box  
 Power rating : DC 19V From Adppter Input AC 120V/60Hz  
 Test Mode : IEEE802.11nHT20 2462MHz Tx Mode  
 M/N : P2571

No.	Freq. (MHz)	Ant. Factor (dB/m)	Cable Loss (dB)	AMP factor (dB)	Reading (dBuV)	Emission Level (dBuV/m)	Limits (dBuV/m)	Margin (dB)	Remark
1	2462.000	28.32	5.89	35.70	107.93	106.44	74.00	-32.44	Peak
2	3811.000	32.15	7.52	35.70	42.61	46.58	74.00	27.42	Peak

No.	Freq. (MHz)	Ant. Factor (dB/m)	Cable Loss (dB)	AMP factor (dB)	Reading (dBuV)	Emission Level (dBuV/m)	Limits (dBuV/m)	Margin (dB)	Remark
1	2462.000	28.32	5.89	35.70	94.76	93.27	74.00	-19.27	Peak
2	3691.000	31.86	7.39	35.70	43.03	46.58	74.00	27.42	Peak

Remarks: 1. Emission Level= Antenna Factor + Cable Loss + Reading -Amp Factor  
 2. The emission levels that are 20dB below the official limit are not reported.

Remarks: 1. Emission Level= Antenna Factor + Cable Loss + Reading -Amp Factor  
 2. The emission levels that are 20dB below the official limit are not reported.

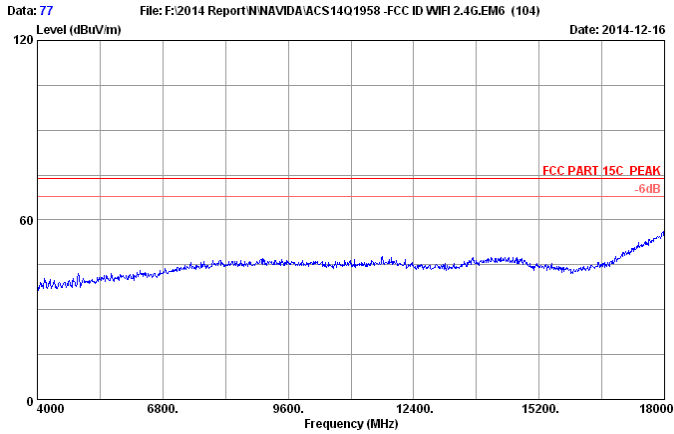

Site no. : 3m Chamber Data no. : 77  
 Dis. / Ant. : 3m 2014 3115 (4580) Ant. pol. : HORIZONTAL  
 Limit : FCC PART 15C PEAK  
 Env. / Ins. : 23°C/54%  
 Engineer : Kobe-Huang  
 EUT : Complex Set-Top Box  
 Power rating : DC 19V From Adpater Input AC 120V/60Hz  
 Test Mode : IEEE802.11nHT20 2462MHz Tx Mode  
 M/N : P2571

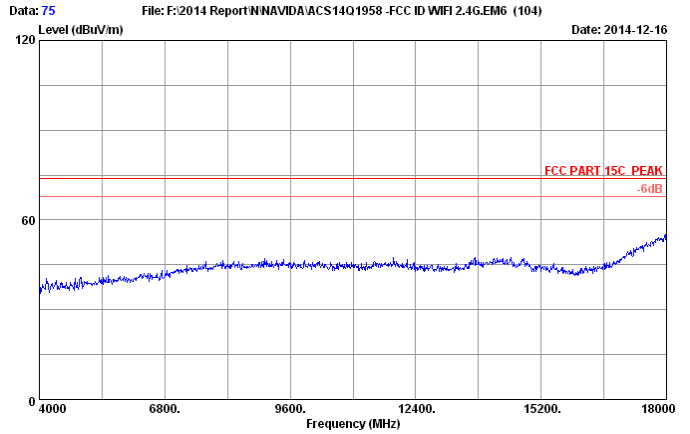

Site no. : 3m Chamber Data no. : 75  
 Dis. / Ant. : 3m 2014 3115 (4580) Ant. pol. : VERTICAL  
 Limit : FCC PART 15C PEAK  
 Env. / Ins. : 23°C/54%  
 Engineer : Kobe-Huang  
 EUT : Complex Set-Top Box  
 Power rating : DC 19V From Adpater Input AC 120V/60Hz  
 Test Mode : IEEE802.11nHT20 2462MHz Tx Mode  
 M/N : P2571

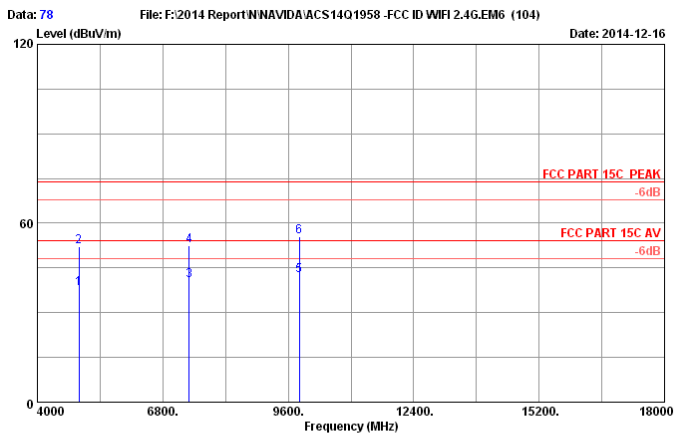

Site no. : 3m Chamber Data no. : 78  
 Dis. / Ant. : 3m 2014 3115 (4580) Ant. pol. : HORIZONTAL  
 Limit : FCC PART 15C PEAK  
 Env. / Ins. : 23°C/54%  
 Engineer : Kobe-Huang  
 EUT : Complex Set-Top Box  
 Power rating : DC 19V From Adpater Input AC 120V/60Hz  
 Test Mode : IEEE802.11nHT20 2462MHz Tx Mode  
 M/N : P2571

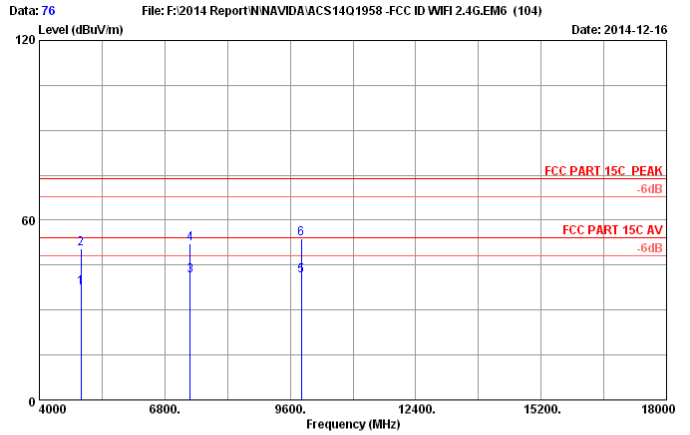

Site no. : 3m Chamber Data no. : 76  
 Dis. / Ant. : 3m 2014 3115 (4580) Ant. pol. : VERTICAL  
 Limit : FCC PART 15C PEAK  
 Env. / Ins. : 23°C/54%  
 Engineer : Kobe-Huang  
 EUT : Complex Set-Top Box  
 Power rating : DC 19V From Adpater Input AC 120V/60Hz  
 Test Mode : IEEE802.11nHT20 2462MHz Tx Mode  
 M/N : P2571

No.	Freq. (MHz)	Ant. Factor (dB/m)	Cable Loss (dB)	AMP factor (dB)	Reading (dBuV)	Emission Level (dBuV/m)	Limits (dBuV/m)	Margin (dB)	Remark
1	4924.000	33.06	8.69	35.70	32.10	38.15	54.00	15.85	Average
2	4924.000	33.06	8.69	35.70	45.95	52.00	74.00	22.00	Peak
3	7386.000	36.35	11.06	35.42	28.88	40.87	54.00	13.13	Average
4	7386.000	36.35	11.06	35.42	40.57	52.56	74.00	21.44	Peak
5	9848.000	37.91	12.35	35.48	27.58	42.36	54.00	11.64	Average
6	9848.000	37.91	12.35	35.48	40.86	55.64	74.00	18.36	Peak

Remarks: 1. Emission Level= Antenna Factor + Cable Loss + Reading - Amp Factor  
 2. The emission levels that are 20dB below the official limit are not reported.

No.	Freq. (MHz)	Ant. Factor (dB/m)	Cable Loss (dB)	AMP factor (dB)	Reading (dBuV)	Emission Level (dBuV/m)	Limits (dBuV/m)	Margin (dB)	Remark
1	4924.000	33.06	8.69	35.70	31.45	37.50	54.00	16.50	Average
2	4924.000	33.06	8.69	35.70	44.29	50.34	74.00	23.66	Peak
3	7386.000	36.31	11.05	35.43	29.56	41.49	54.00	12.51	Average
4	7386.000	36.31	11.05	35.43	40.37	52.30	74.00	21.70	Peak
5	9848.000	37.91	12.35	35.48	26.53	41.31	54.00	12.69	Average
6	9848.000	37.91	12.35	35.48	39.17	53.95	74.00	20.05	Peak

Remarks: 1. Emission Level= Antenna Factor + Cable Loss + Reading - Amp Factor  
 2. The emission levels that are 20dB below the official limit are not reported.

**Test Mode: IEEE 802.11n HT40**

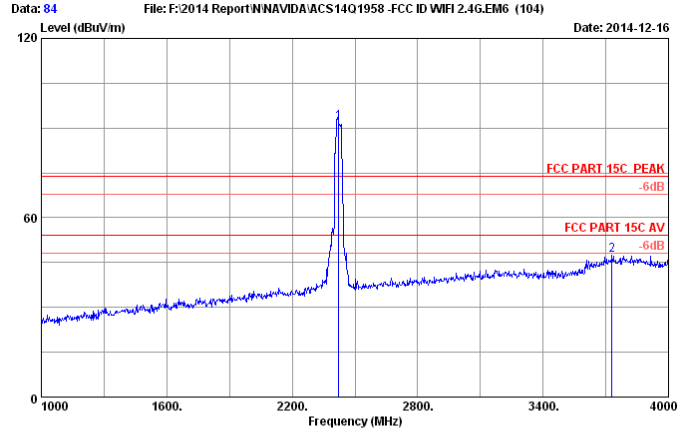
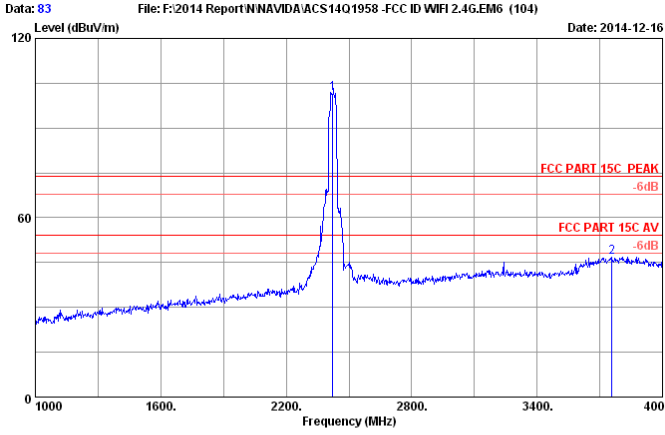

Site no. : 3m Chamber Data no. : 83  
 Dis. / Ant. : 3m 2014 3115 (4580) Ant. pol. : HORIZONTAL  
 Limit : FCC PART 15C PEAK  
 Env. / Ins. : 23°C/54%  
 Engineer : Kobe-Huang  
 EUT : Complex Set-Top Box  
 Power rating : DC 19V From Adppter Input AC 120V/60Hz  
 Test Mode : IEEE802.11nHT40 2422MHz Tx Mode  
 M/N : P2571

Site no. : 3m Chamber Data no. : 84  
 Dis. / Ant. : 3m 2014 3115 (4580) Ant. pol. : VERTICAL  
 Limit : FCC PART 15C PEAK  
 Env. / Ins. : 23°C/54%  
 Engineer : Kobe-Huang  
 EUT : Complex Set-Top Box  
 Power rating : DC 19V From Adppter Input AC 120V/60Hz  
 Test Mode : IEEE802.11nHT40 2422MHz Tx Mode  
 M/N : P2571

No.	Freq. (MHz)	Ant. Factor (dB/m)	Cable Loss (dB)	AMP factor (dB)	Reading (dBuV)	Emission Level (dBuV/m)	Limits (dBuV/m)	Margin (dB)	Remark
1	2422.000	28.23	5.83	35.70	103.25	101.61	74.00	-27.61	Peak
2	3757.000	32.02	7.46	35.70	43.18	46.96	74.00	27.04	Peak

No.	Freq. (MHz)	Ant. Factor (dB/m)	Cable Loss (dB)	AMP factor (dB)	Reading (dBuV)	Emission Level (dBuV/m)	Limits (dBuV/m)	Margin (dB)	Remark
1	2422.000	28.23	5.83	35.70	93.68	92.04	74.00	-18.04	Peak
2	3730.000	31.95	7.43	35.70	43.68	47.36	74.00	26.64	Peak

Remarks: 1. Emission Level= Antenna Factor + Cable Loss + Reading -amp Factor  
 2. The emission levels that are 20dB below the official limit are not reported.

Remarks: 1. Emission Level= Antenna Factor + Cable Loss + Reading -amp Factor  
 2. The emission levels that are 20dB below the official limit are not reported.

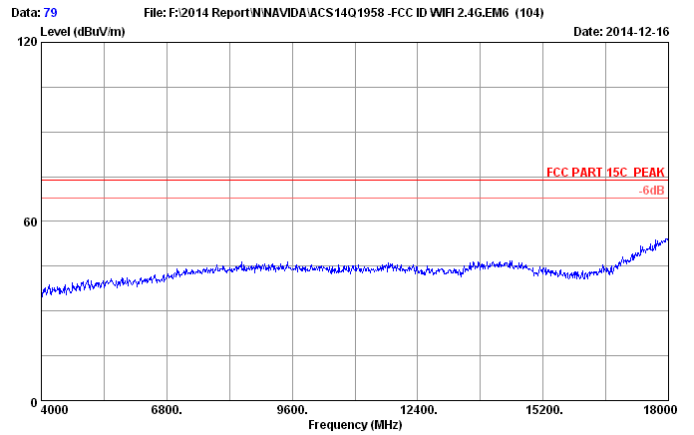
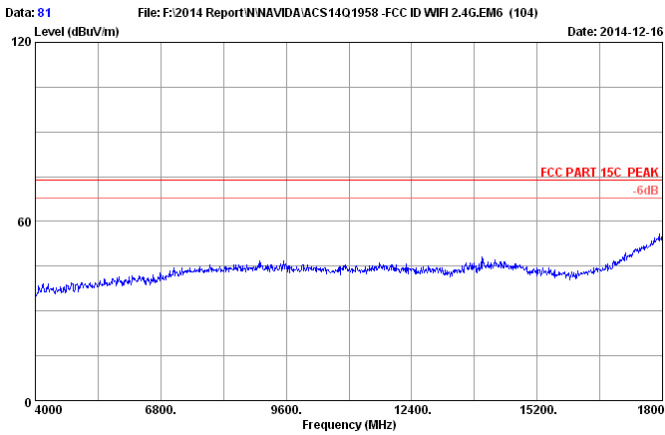

Site no. : 3m Chamber Data no. : 81  
 Dis. / Ant. : 3m 2014 3115 (4580) Ant. pol. : HORIZONTAL  
 Limit : FCC PART 15C PEAK  
 Env. / Ins. : 23°C/54%  
 Engineer : Kobe-Huang  
 EUT : Complex Set-Top Box  
 Power rating : DC 19V From Adppter Input AC 120V/60Hz  
 Test Mode : IEEE802.11nHT40 2422MHz Tx Mode  
 M/N : P2571

Site no. : 3m Chamber Data no. : 79  
 Dis. / Ant. : 3m 2014 3115 (4580) Ant. pol. : VERTICAL  
 Limit : FCC PART 15C PEAK  
 Env. / Ins. : 23°C/54%  
 Engineer : Kobe-Huang  
 EUT : Complex Set-Top Box  
 Power rating : DC 19V From Adppter Input AC 120V/60Hz  
 Test Mode : IEEE802.11nHT40 2422MHz Tx Mode  
 M/N : P2571



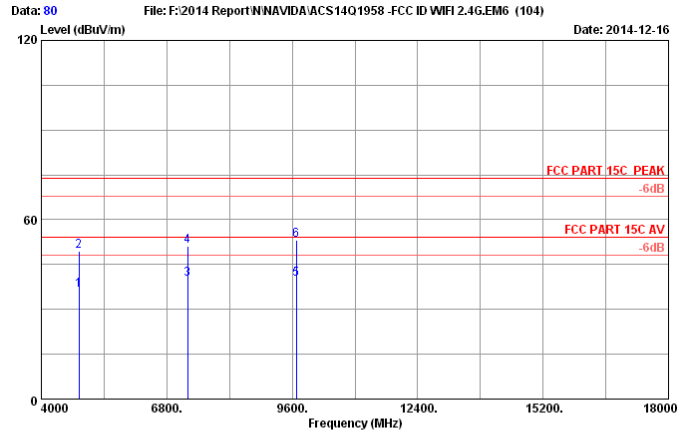
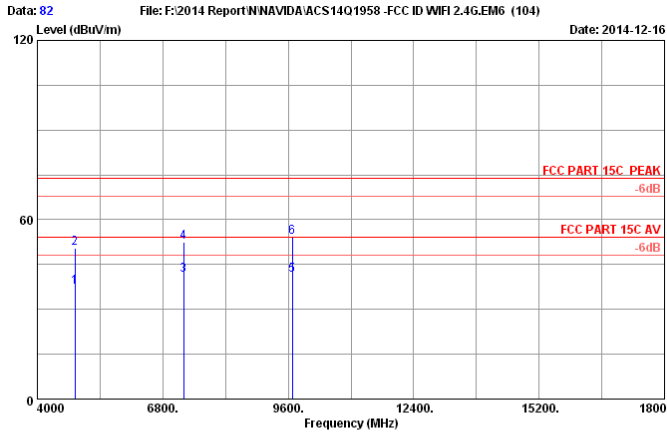

Site no. : 3m Chamber Data no. : 82  
 Dis. / Ant. : 3m 2014 3115 (4580) Ant. pol. : HORIZONTAL  
 Limit : FCC PART 15C PEAK  
 Env. / Ins. : 23°C/54%  
 Engineer : Kobe-Huang  
 EUT : Complex Set-Top Box  
 Power rating : DC 19V From Adpater Input AC 120V/60Hz  
 Test Mode : IEEE802.11nHT40 2422MHz Tx Mode  
 M/N : P2571

Site no. : 3m Chamber Data no. : 80  
 Dis. / Ant. : 3m 2014 3115 (4580) Ant. pol. : VERTICAL  
 Limit : FCC PART 15C PEAK  
 Env. / Ins. : 23°C/54%  
 Engineer : Kobe-Huang  
 EUT : Complex Set-Top Box  
 Power rating : DC 19V From Adpater Input AC 120V/60Hz  
 Test Mode : IEEE802.11nHT40 2422MHz Tx Mode  
 M/N : P2571

No.	Freq. (MHz)	Ant. Factor (dB/m)	Cable Loss (dB)	AMP factor (dB)	Reading (dBuV)	Emission Level (dBuV/m)	Limits (dBuV/m)	Margin (dB)	Remark
1	4844.000	32.92	8.60	35.70	31.69	37.51	54.00	16.49	Average
2	4844.000	32.92	8.60	35.70	44.77	50.59	74.00	23.41	Peak
3	7266.000	36.09	11.00	35.45	29.69	41.33	54.00	12.67	Average
4	7266.000	36.09	11.00	35.45	40.78	52.42	74.00	21.58	Peak
5	9688.000	37.81	12.27	35.47	26.74	41.35	54.00	12.65	Average
6	9688.000	37.81	12.27	35.47	39.57	54.18	74.00	19.82	Peak

No.	Freq. (MHz)	Ant. Factor (dB/m)	Cable Loss (dB)	AMP factor (dB)	Reading (dBuV)	Emission Level (dBuV/m)	Limits (dBuV/m)	Margin (dB)	Remark
1	4844.000	32.92	8.60	35.70	30.66	36.48	54.00	17.52	Average
2	4844.000	32.92	8.60	35.70	43.57	49.39	74.00	24.61	Peak
3	7266.000	36.09	11.00	35.45	28.55	40.19	54.00	13.81	Average
4	7266.000	36.09	11.00	35.45	39.37	51.01	74.00	22.99	Peak
5	9688.000	37.81	12.27	35.47	25.58	40.19	54.00	13.81	Average
6	9688.000	37.81	12.27	35.47	38.37	52.98	74.00	21.02	Peak

Remarks: 1. Emission Level= Antenna Factor + Cable Loss + Reading - Amp Factor  
 2. The emission levels that are 20dB below the official limit are not reported.

Remarks: 1. Emission Level= Antenna Factor + Cable Loss + Reading - Amp Factor  
 2. The emission levels that are 20dB below the official limit are not reported.

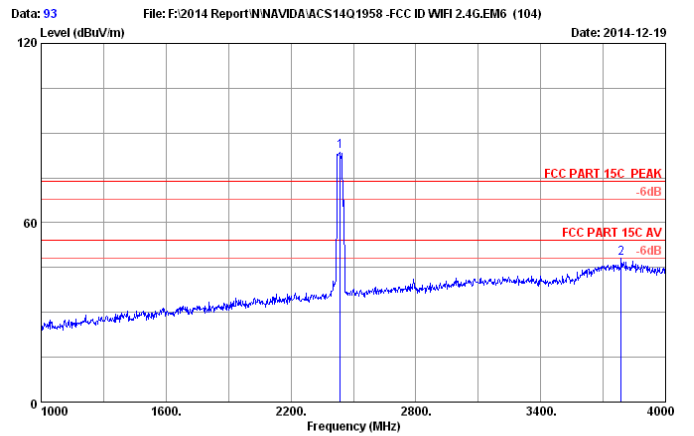
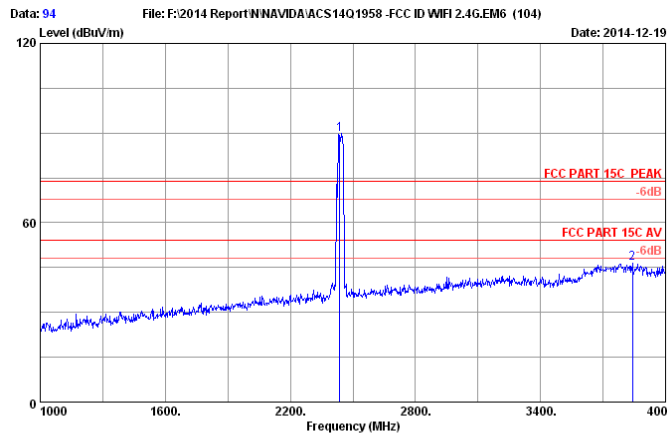

Site no. : 3m Chamber Data no. : 94  
 Dis. / Ant. : 3m 2014 3115 (4580) Ant. pol. : HORIZONTAL  
 Limit : FCC PART 15C PEAK  
 Env. / Ins. : 23°C/54%  
 Engineer : Kobe-Huang  
 EUT : Complex Set-Top Box  
 Power rating : DC 19V From Adpater Input AC 120V/60Hz  
 Test Mode : IEEE802.11nHT40 2437MHz Tx Mode  
 M/N : P2571

Site no. : 3m Chamber Data no. : 93  
 Dis. / Ant. : 3m 2014 3115 (4580) Ant. pol. : VERTICAL  
 Limit : FCC PART 15C PEAK  
 Env. / Ins. : 23°C/54%  
 Engineer : Kobe-Huang  
 EUT : Complex Set-Top Box  
 Power rating : DC 19V From Adpater Input AC 120V/60Hz  
 Test Mode : IEEE802.11nHT40 2437MHz Tx Mode  
 M/N : P2571

No.	Freq. (MHz)	Ant. Factor (dB/m)	Cable Loss (dB)	AMP factor (dB)	Reading (dBuV)	Emission Level (dBuV/m)	Limits (dBuV/m)	Margin (dB)	Remark
1	2437.000	28.26	5.85	35.70	91.27	89.68	74.00	-15.68	Peak
2	3841.000	32.22	7.55	35.70	42.31	46.38	74.00	27.62	Peak

No.	Freq. (MHz)	Ant. Factor (dB/m)	Cable Loss (dB)	AMP factor (dB)	Reading (dBuV)	Emission Level (dBuV/m)	Limits (dBuV/m)	Margin (dB)	Remark
1	2437.000	28.26	5.85	35.70	85.37	83.78	74.00	-9.78	Peak
2	3787.000	32.09	7.49	35.70	44.25	48.13	74.00	25.87	Peak

Remarks: 1. Emission Level= Antenna Factor + Cable Loss + Reading - Amp Factor  
 2. The emission levels that are 20dB below the official limit are not reported.

Remarks: 1. Emission Level= Antenna Factor + Cable Loss + Reading - Amp Factor  
 2. The emission levels that are 20dB below the official limit are not reported.

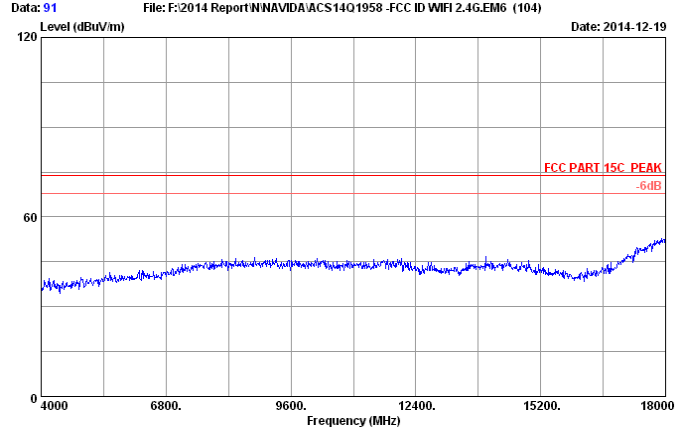
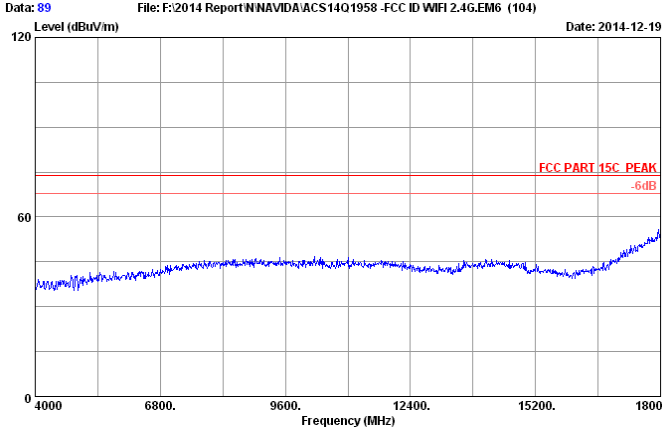

Site no. : 3m Chamber Data no. : 89  
 Dis. / Ant. : 3m 2014 3115 (4580) Ant. pol. : HORIZONTAL  
 Limit : FCC PART 15C PEAK  
 Env. / Ins. : 23°C/54%  
 Engineer : Kobe-Huang  
 EUT : Complex Set-Top Box  
 Power rating : DC 19V From Adppter Input AC 120V/60Hz  
 Test Mode : IEEE802.11nHT40 2437MHz Tx Mode  
 M/N : P2571

Site no. : 3m Chamber Data no. : 91  
 Dis. / Ant. : 3m 2014 3115 (4580) Ant. pol. : VERTICAL  
 Limit : FCC PART 15C PEAK  
 Env. / Ins. : 23°C/54%  
 Engineer : Kobe-Huang  
 EUT : Complex Set-Top Box  
 Power rating : DC 19V From Adppter Input AC 120V/60Hz  
 Test Mode : IEEE802.11nHT40 2437MHz Tx Mode  
 M/N : P2571

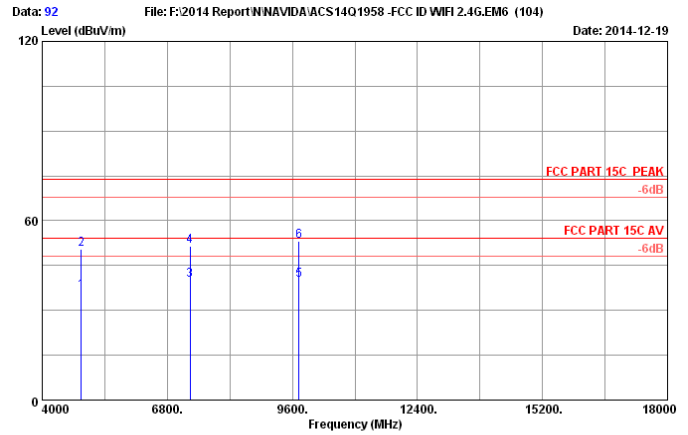
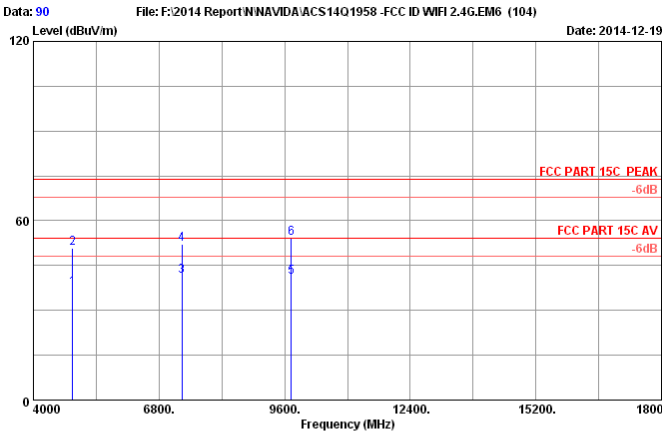

Site no. : 3m Chamber Data no. : 90  
 Dis. / Ant. : 3m 2014 3115 (4580) Ant. pol. : HORIZONTAL  
 Limit : FCC PART 15C PEAK  
 Env. / Ins. : 23°C/54%  
 Engineer : Kobe-Huang  
 EUT : Complex Set-Top Box  
 Power rating : DC 19V From Adppter Input AC 120V/60Hz  
 Test Mode : IEEE802.11nHT40 2437MHz Tx Mode  
 M/N : P2571

Site no. : 3m Chamber Data no. : 92  
 Dis. / Ant. : 3m 2014 3115 (4580) Ant. pol. : VERTICAL  
 Limit : FCC PART 15C PEAK  
 Env. / Ins. : 23°C/54%  
 Engineer : Kobe-Huang  
 EUT : Complex Set-Top Box  
 Power rating : DC 19V From Adppter Input AC 120V/60Hz  
 Test Mode : IEEE802.11nHT40 2437MHz Tx Mode  
 M/N : P2571

No.	Freq. (MHz)	Ant. Factor (dB/m)	Cable Loss (dB)	AMP factor (dB)	Reading (dBuV)	Emission Level (dBuV/m)	Limits (dBuV/m)	Margin (dB)	Remark
1	4874.000	32.97	8.63	35.70	31.55	37.45	54.00	16.55	Average
2	4874.000	32.97	8.63	35.70	44.90	50.80	74.00	23.20	Peak
3	7311.000	36.18	11.02	35.44	29.69	41.45	54.00	12.55	Average
4	7311.000	36.18	11.02	35.44	40.38	52.14	74.00	21.86	Peak
5	9748.000	37.85	12.30	35.47	26.37	41.05	54.00	12.95	Average
6	9748.000	37.85	12.30	35.47	39.44	54.12	74.00	19.88	Peak

No.	Freq. (MHz)	Ant. Factor (dB/m)	Cable Loss (dB)	AMP factor (dB)	Reading (dBuV)	Emission Level (dBuV/m)	Limits (dBuV/m)	Margin (dB)	Remark
1	4874.000	32.97	8.63	35.70	30.58	36.48	54.00	17.52	Average
2	4874.000	32.97	8.63	35.70	44.67	50.57	74.00	23.43	Peak
3	7311.000	36.18	11.02	35.44	28.37	40.13	54.00	13.87	Average
4	7311.000	36.18	11.02	35.44	39.79	51.55	74.00	22.45	Peak
5	9748.000	37.85	12.30	35.47	25.36	40.04	54.00	13.96	Average
6	9748.000	37.85	12.30	35.47	38.58	53.26	74.00	20.74	Peak

Remarks: 1. Emission Level= Antenna Factor + Cable Loss + Reading - Amp Factor  
 2. The emission levels that are 20dB below the official limit are not reported.

Remarks: 1. Emission Level= Antenna Factor + Cable Loss + Reading - Amp Factor  
 2. The emission levels that are 20dB below the official limit are not reported.

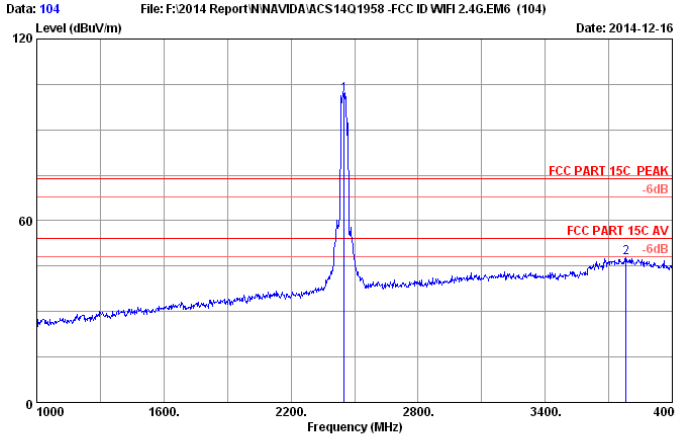

Site no. : 3m Chamber Data no. : 104  
 Dis. / Ant. : 3m 2014 3115 (4580) Ant. pol. : HORIZONTAL  
 Limit : FCC PART 15C PEAK  
 Env. / Ins. : 23°C/54%  
 Engineer : Kobe-Huang  
 EUT : Complex Set-Top Box  
 Power rating : DC 19V From Adppter Input AC 120V/60Hz  
 Test Mode : IEEE802.11nHT40 2452MHz Tx Mode  
 M/N : P2571

No.	Freq. (MHz)	Ant. Factor (dB/m)	Cable Loss (dB)	AMP factor (dB)	Reading (dBuV)	Emission Level (dBuV/m)	Limits (dBuV/m)	Margin (dB)	Remark
1	2452.000	28.29	5.87	35.70	103.27	101.73	74.00	-27.73	Peak
2	3781.000	32.07	7.49	35.70	43.93	47.79	74.00	26.21	Peak

Remarks: 1. Emission Level= Antenna Factor + Cable Loss + Reading - Amp Factor  
 2. The emission levels that are 20dB below the official limit are not reported.

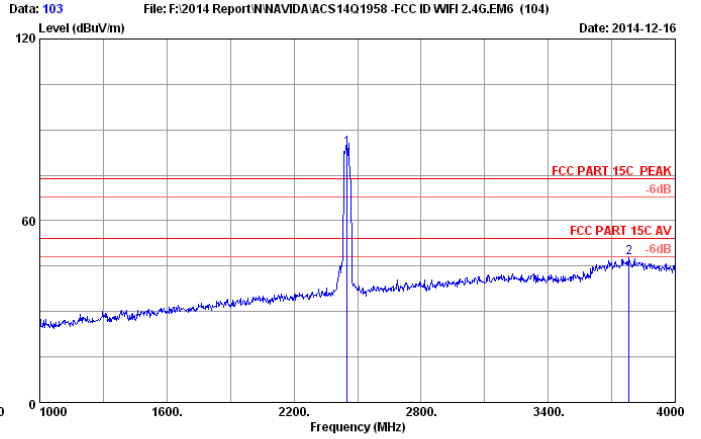

Site no. : 3m Chamber Data no. : 103  
 Dis. / Ant. : 3m 2014 3115 (4580) Ant. pol. : VERTICAL  
 Limit : FCC PART 15C PEAK  
 Env. / Ins. : 23°C/54%  
 Engineer : Kobe-Huang  
 EUT : Complex Set-Top Box  
 Power rating : DC 19V From Adppter Input AC 120V/60Hz  
 Test Mode : IEEE802.11nHT40 2452MHz Tx Mode  
 M/N : P2571

No.	Freq. (MHz)	Ant. Factor (dB/m)	Cable Loss (dB)	AMP factor (dB)	Reading (dBuV)	Emission Level (dBuV/m)	Limits (dBuV/m)	Margin (dB)	Remark
1	2452.000	28.29	5.87	35.70	85.58	84.04	74.00	-10.04	Peak
2	3781.000	32.07	7.49	35.70	43.93	47.79	74.00	26.21	Peak

Remarks: 1. Emission Level= Antenna Factor + Cable Loss + Reading - Amp Factor  
 2. The emission levels that are 20dB below the official limit are not reported.

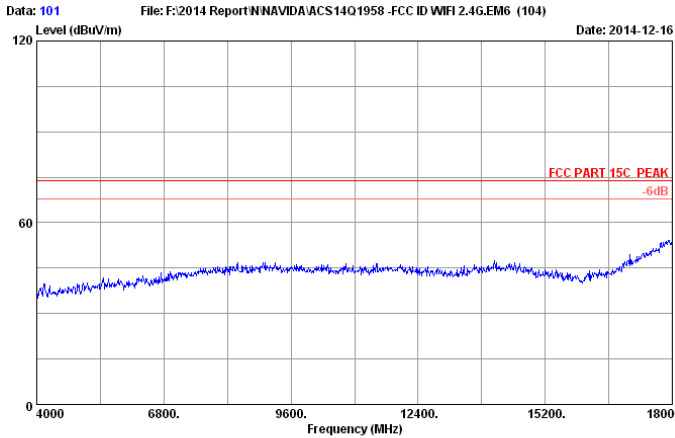

Site no. : 3m Chamber Data no. : 101  
 Dis. / Ant. : 3m 2014 3115 (4580) Ant. pol. : HORIZONTAL  
 Limit : FCC PART 15C PEAK  
 Env. / Ins. : 23°C/54%  
 Engineer : Kobe-Huang  
 EUT : Complex Set-Top Box  
 Power rating : DC 19V From Adppter Input AC 120V/60Hz  
 Test Mode : IEEE802.11nHT40 2452MHz Tx Mode  
 M/N : P2571

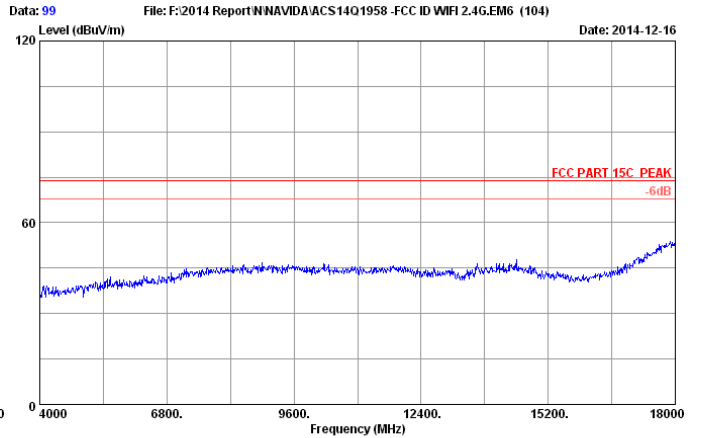

Site no. : 3m Chamber Data no. : 99  
 Dis. / Ant. : 3m 2014 3115 (4580) Ant. pol. : VERTICAL  
 Limit : FCC PART 15C PEAK  
 Env. / Ins. : 23°C/54%  
 Engineer : Kobe-Huang  
 EUT : Complex Set-Top Box  
 Power rating : DC 19V From Adppter Input AC 120V/60Hz  
 Test Mode : IEEE802.11nHT40 2452MHz Tx Mode  
 M/N : P2571

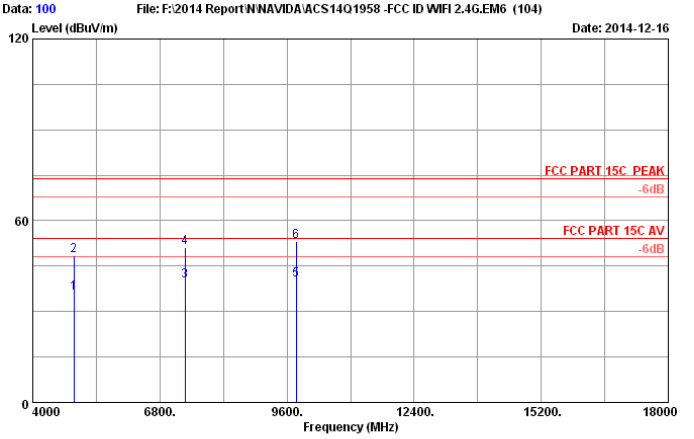
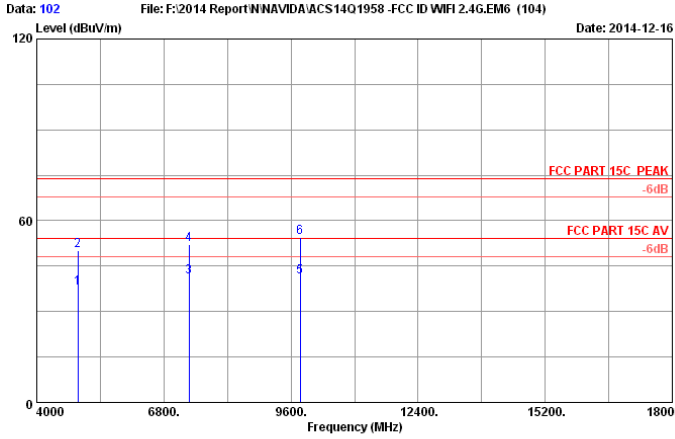

Site no. : 3m Chamber Data no. : 102  
 Dis. / Ant. : 3m 2014 3115 (4580) Ant. pol. : HORIZONTAL  
 Limit : FCC PART 15C PEAK  
 Env. / Ins. : 23°C/54%  
 Engineer : Kobe-Huang  
 EUT : Complex Set-Top Box  
 Power rating : DC 19V From Adppter Input AC 120V/60Hz  
 Test Mode : IEEE802.11nHT40 2452MHz Tx Mode  
 M/N : P2571

Site no. : 3m Chamber Data no. : 100  
 Dis. / Ant. : 3m 2014 3115 (4580) Ant. pol. : VERTICAL  
 Limit : FCC PART 15C PEAK  
 Env. / Ins. : 23°C/54%  
 Engineer : Kobe-Huang  
 EUT : Complex Set-Top Box  
 Power rating : DC 19V From Adppter Input AC 120V/60Hz  
 Test Mode : IEEE802.11nHT40 2452MHz Tx Mode  
 M/N : P2571

No.	Freq. (MHz)	Ant. Factor (dB/m)	Cable Loss (dB)	AMP factor (dB)	Reading (dBuV)	Emission Level (dBuV/m)	Limits (dBuV/m)	Margin (dB)	Remark
1	4904.000	33.03	8.66	35.70	31.69	37.68	54.00	16.32	Average
2	4904.000	33.03	8.66	35.70	44.15	50.14	74.00	23.86	Peak
3	7356.000	36.28	11.05	35.43	29.44	41.34	54.00	12.66	Average
4	7356.000	36.28	11.05	35.43	40.37	52.27	74.00	21.73	Peak
5	9808.000	37.88	12.33	35.48	26.64	41.37	54.00	12.63	Average
6	9808.000	37.88	12.33	35.48	39.87	54.60	74.00	19.40	Peak

Remarks: 1. Emission Level= Antenna Factor + Cable Loss + Reading - Amp Factor  
 2. The emission levels that are 20dB below the official limit are not reported.

No.	Freq. (MHz)	Ant. Factor (dB/m)	Cable Loss (dB)	AMP factor (dB)	Reading (dBuV)	Emission Level (dBuV/m)	Limits (dBuV/m)	Margin (dB)	Remark
1	4904.000	33.03	8.66	35.70	30.12	36.11	54.00	17.89	Average
2	4904.000	33.03	8.66	35.70	42.57	48.56	74.00	25.44	Peak
3	7356.000	36.28	11.05	35.43	28.14	40.04	54.00	13.96	Average
4	7356.000	36.28	11.05	35.43	39.14	51.04	74.00	22.96	Peak
5	9808.000	37.88	12.33	35.48	25.59	40.32	54.00	13.68	Average
6	9808.000	37.88	12.33	35.48	38.41	53.14	74.00	20.86	Peak

Remarks: 1. Emission Level= Antenna Factor + Cable Loss + Reading - Amp Factor  
 2. The emission levels that are 20dB below the official limit are not reported.

## 5. CONDUCTED SPURIOUS EMISSIONS

### 5.1. Test Equipment

Item	Equipment	Manufacturer	Model No.	Serial No.	Last Cal.	Cal. Interval
1.	Spectrum	Agilent	N9030A	MY51380221	Oct.29, 14	1 Year
2.	Attenuator (20dB)	Agilent	8491B	MY39262165	Apr. 28,14	1 Year
3.	RF Cable	Hubersuhner	SUCOFLEX102	28620/2	Apr. 28,14	1 Year

### 5.2. Limit

In any 100kHz bandwidth outside the frequency bands in which the spread spectrum intentional radiator is operating, the radio frequency power that is produced by the intentional radiator shall be at least 20dB below that in the 100kHz bandwidth within the band that contains the highest level of the desired power.

### 5.3. Test Procedure

The transmitter output was connected to a spectrum analyzer, The resolution bandwidth is set to 100 kHz, The video bandwidth is set to 300 kHz and measure all the emissions with peak detector.

### 5.4. Test result

**PASS** (The testing data was attached in the next pages.)

**ANT 1**

Test Mode: IEEE 802.11b TX

Test CH1: 2412MHz(30MHz – 1GHz)

Test CH1: 2412MHz(10GHz – 25GHz)

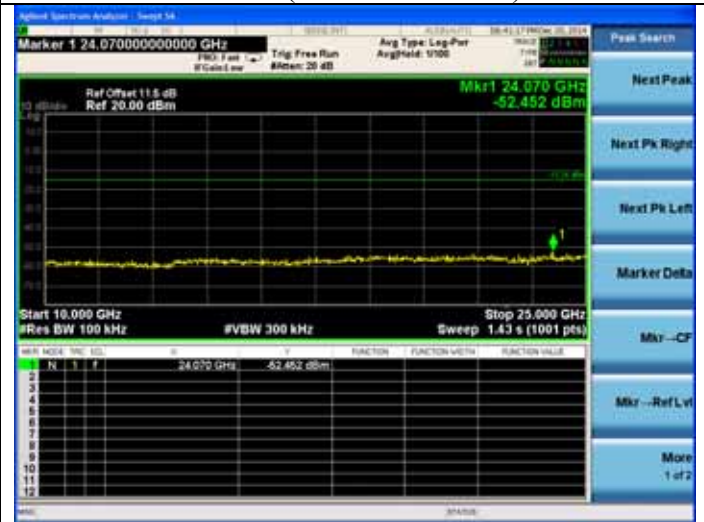
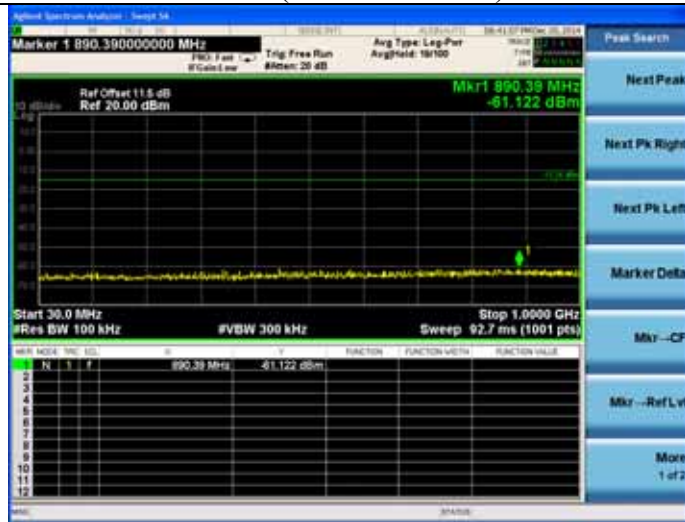

Test CH1: 2412MHz(1GHz – 10GHz)

Test CH6: 2437MHz(30MHz – 1GHz)

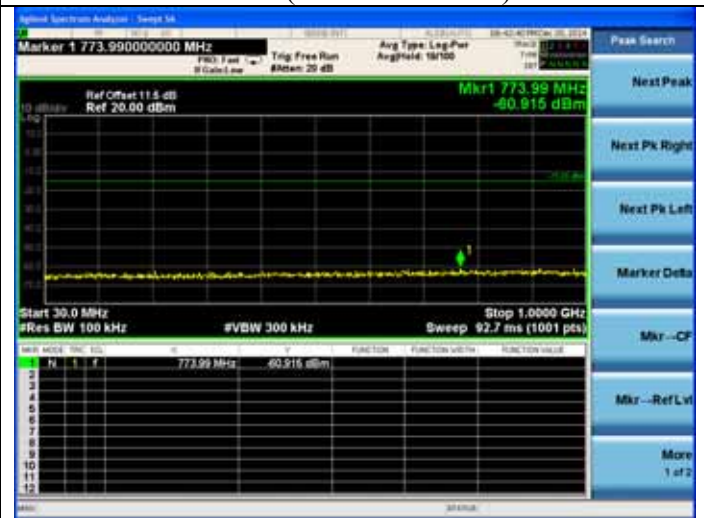
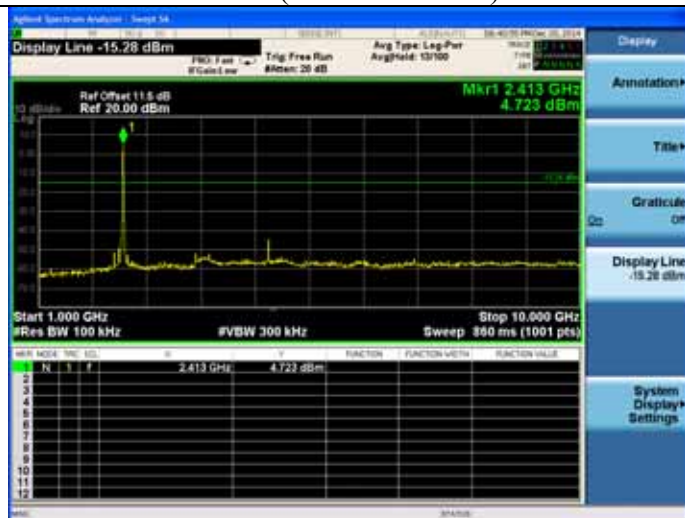

Test CH1: 2412MHz(2.31GHz – 2.425GHz)

Test CH6: 2437MHz(1GHz – 10GHz)

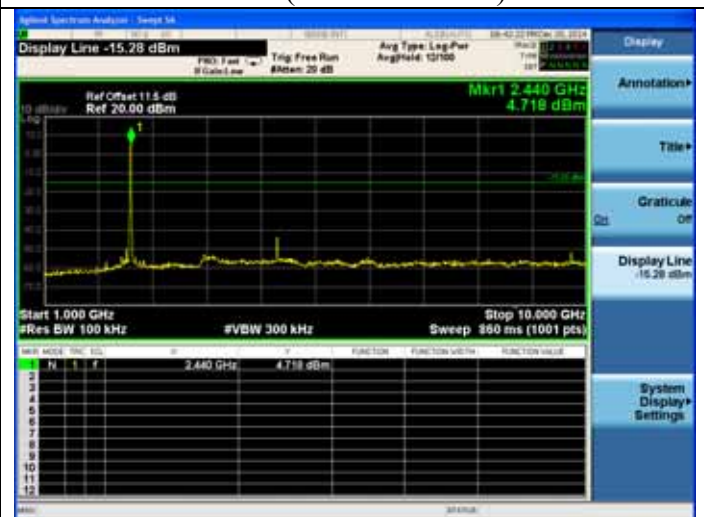

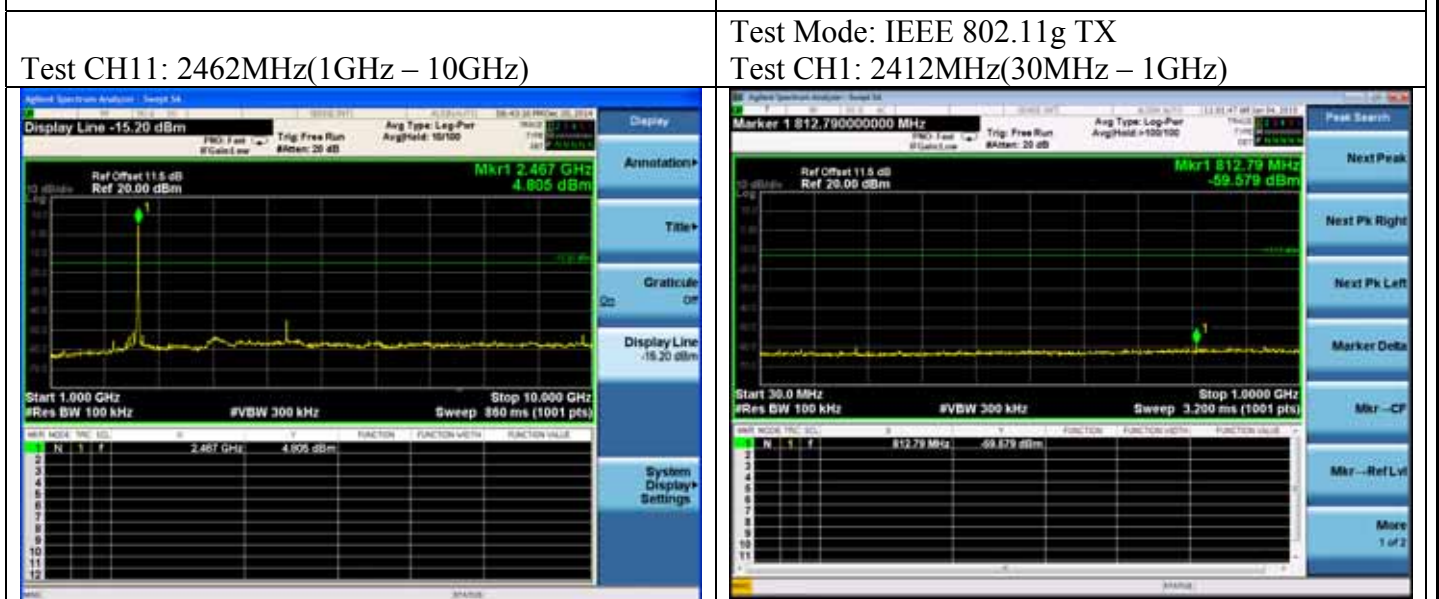
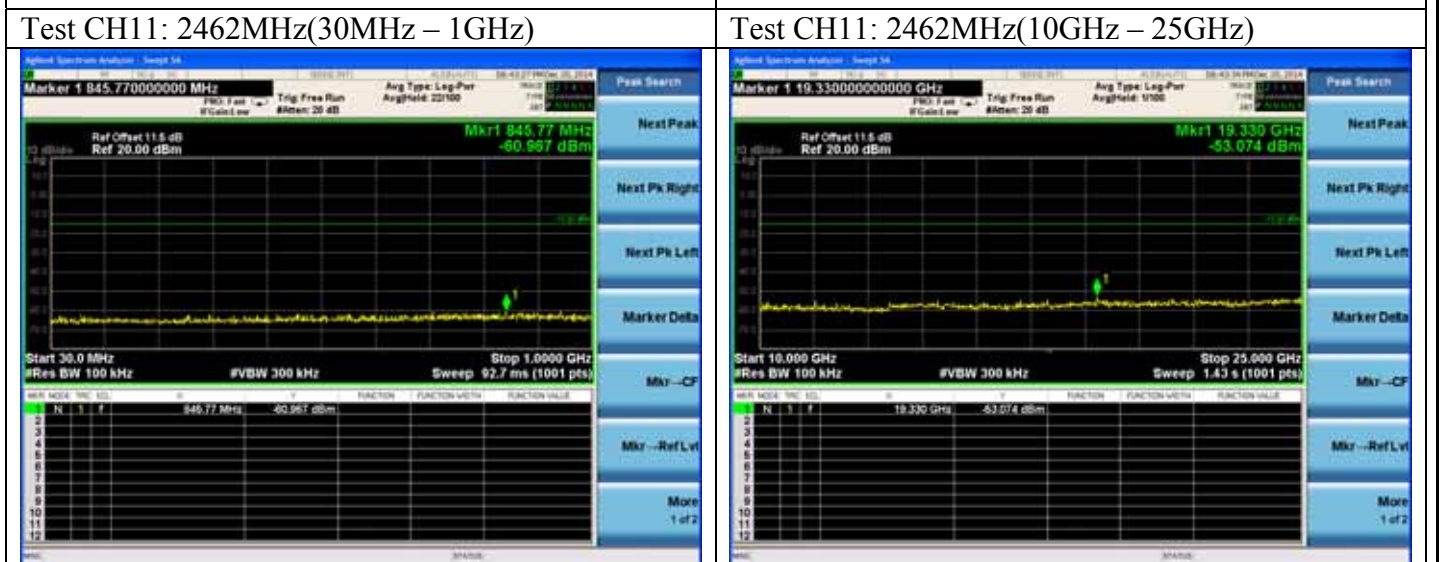
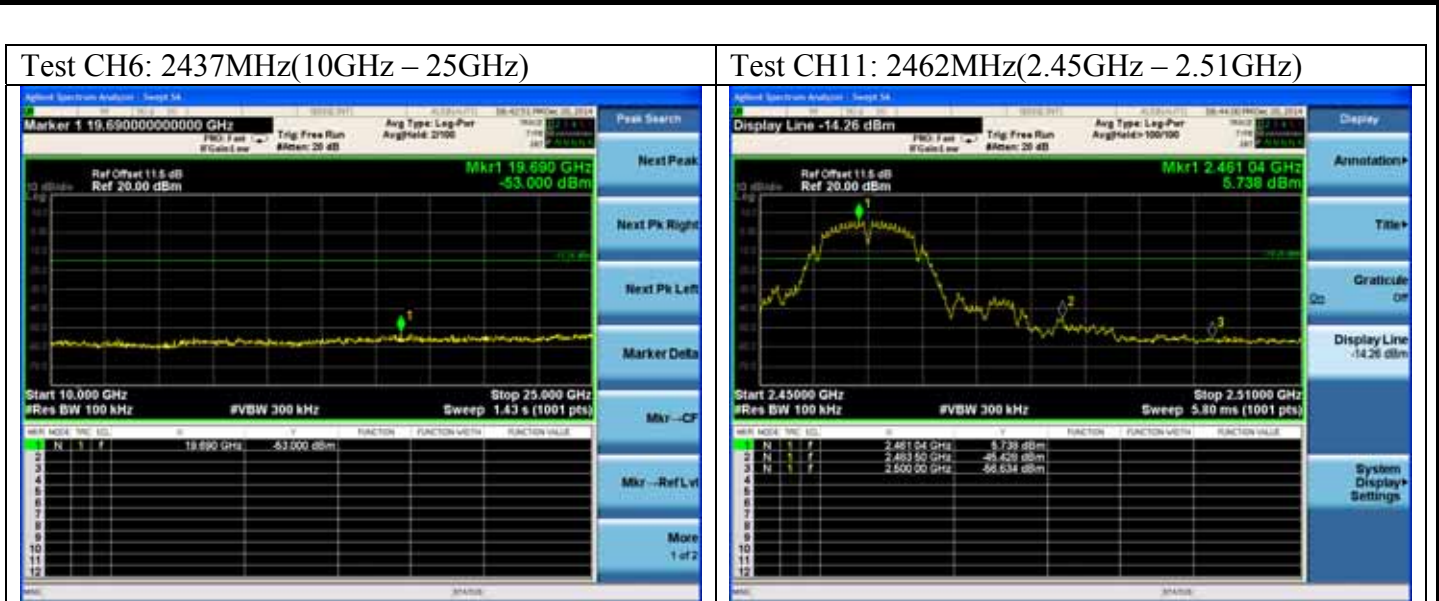

Test CH1: 2412MHz(1GHz – 10GHz)

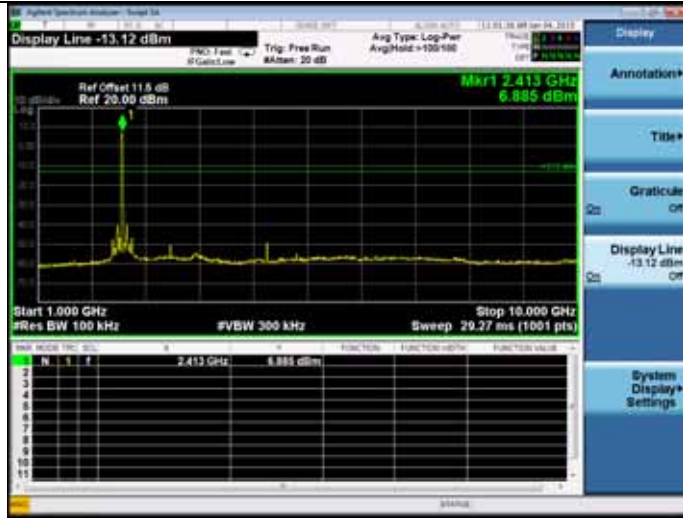

Test CH6: 2437MHz(30MHz – 1GHz)

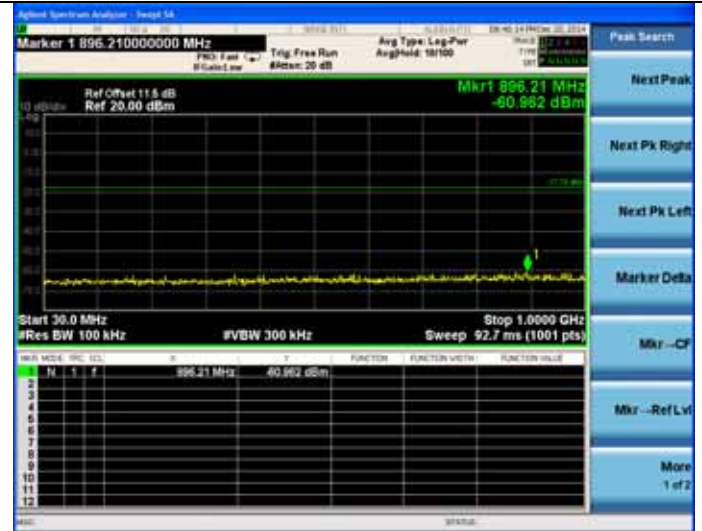

Test CH1: 2412MHz(2.31MHz – 2.425GHz)



Test CH6: 2437MHz(1GHz – 10GHz)

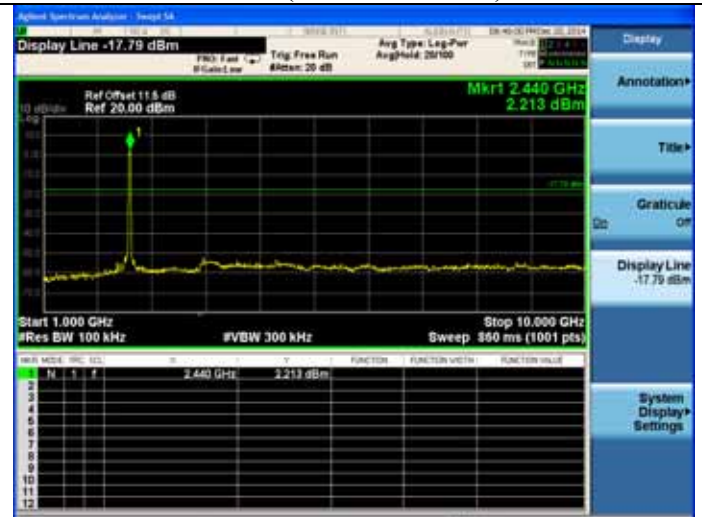

Test CH1: 2412MHz(10GHz – 25GHz)

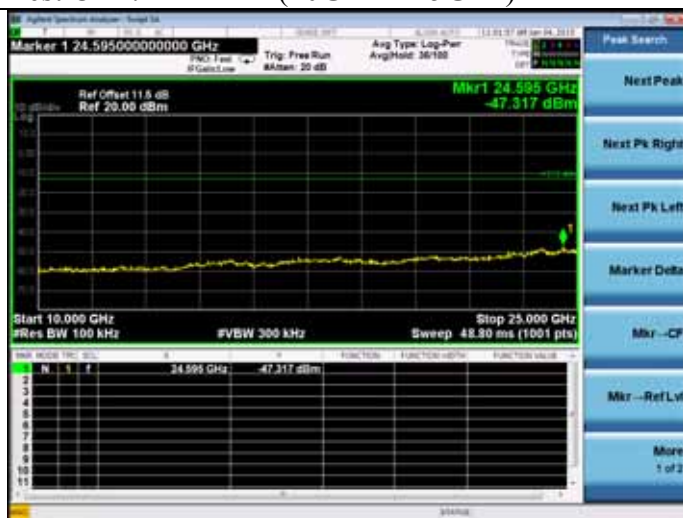

Test CH6: 2437MHz(10GHz – 25GHz)

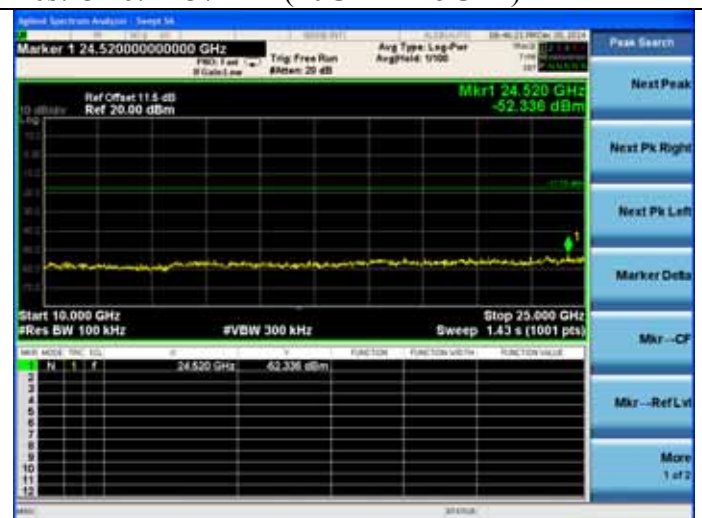





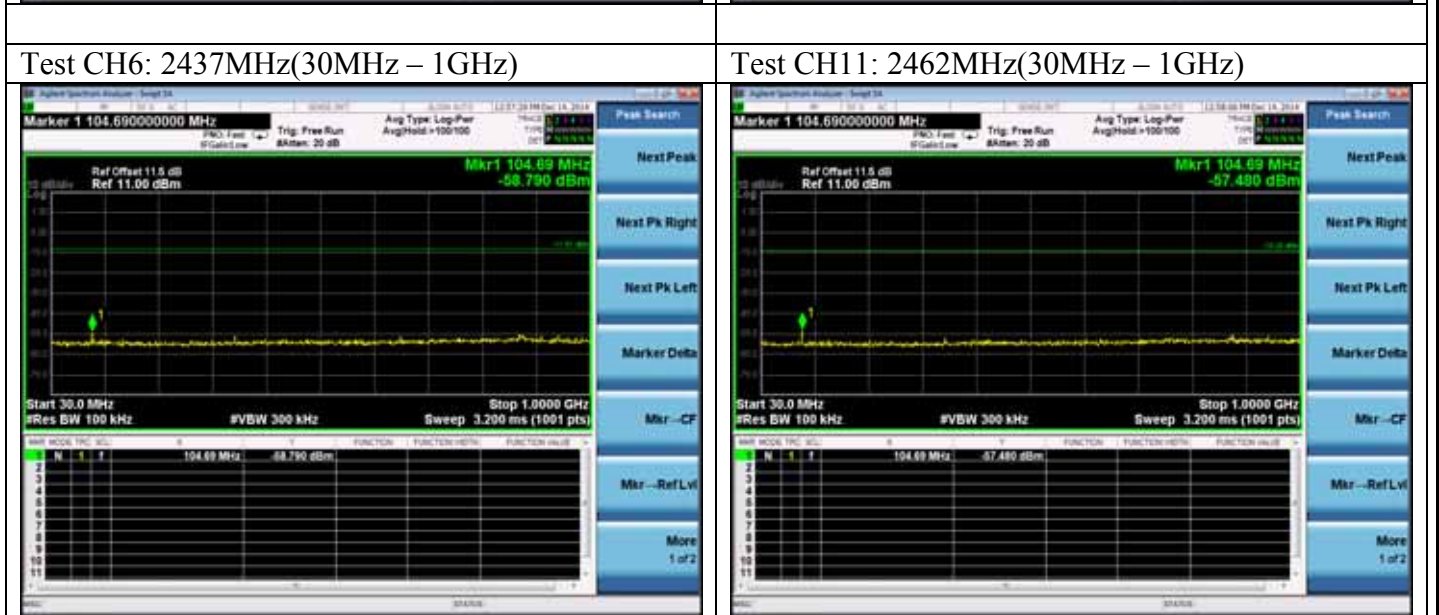
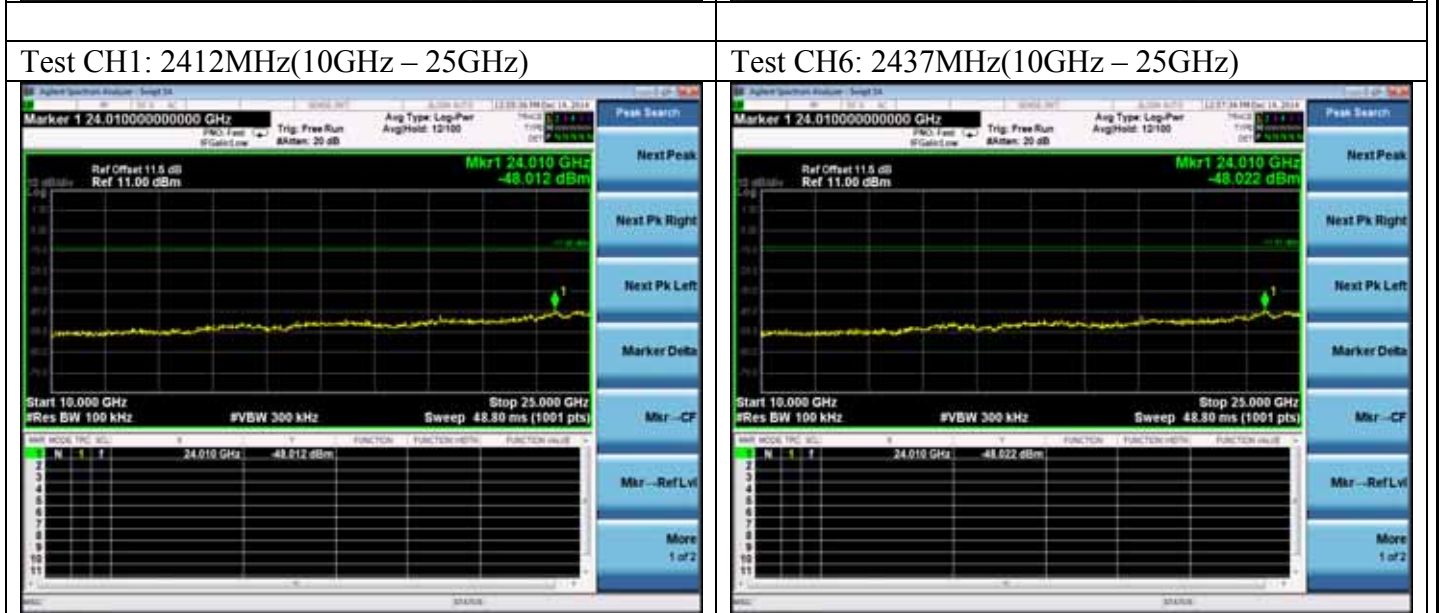
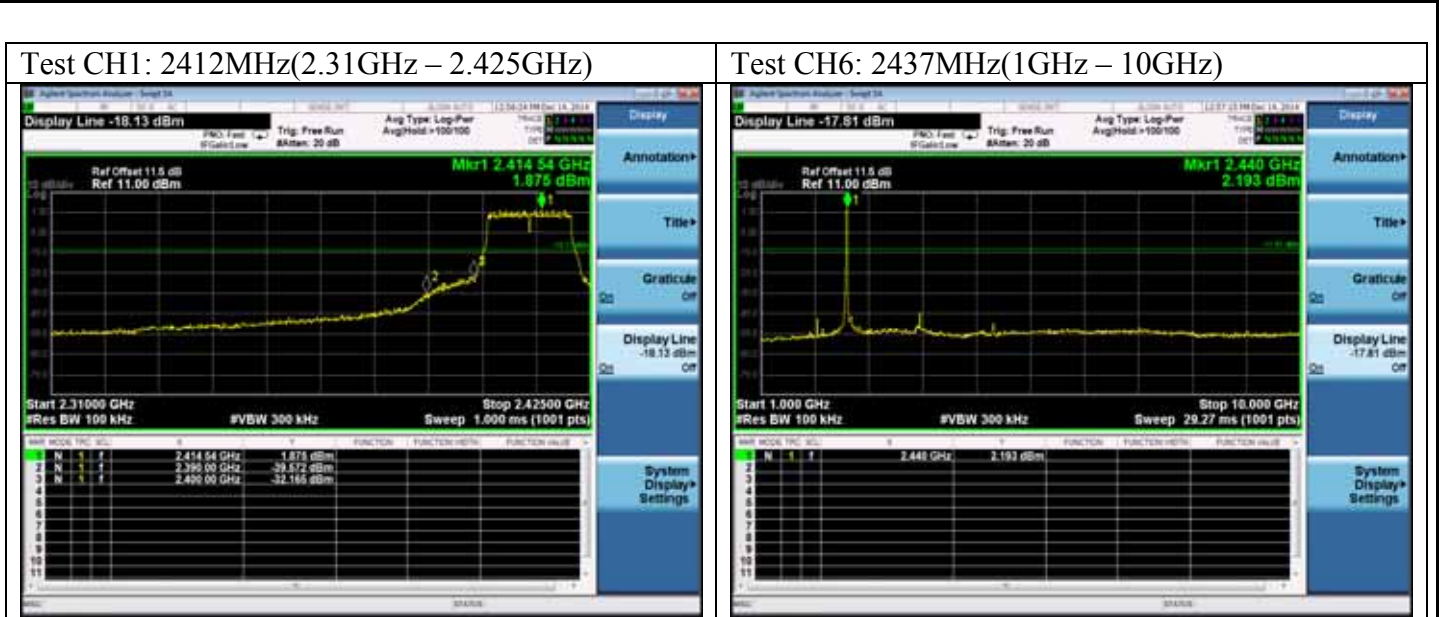

Test CH11: 2462MHz(1GHz – 10GHz)

Test Mode: IEEE 802.11n HT40 TX  
Test CH1: 2422MHz(30MHz – 1GHz)

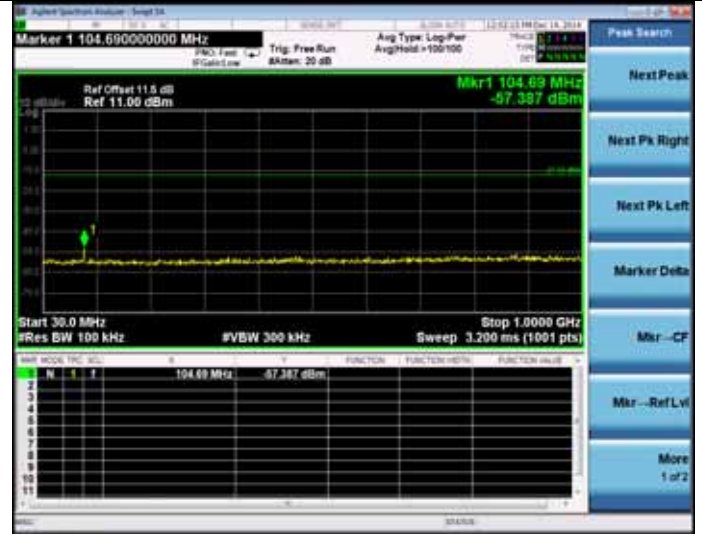
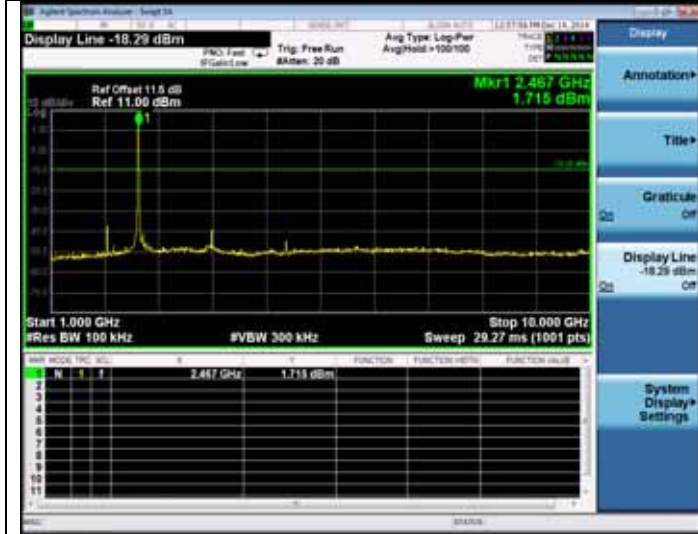

Test CH11: 2462MHz(2.45GHz – 2.51GHz)

Test CH1: 2422MHz(1GHz – 10GHz)

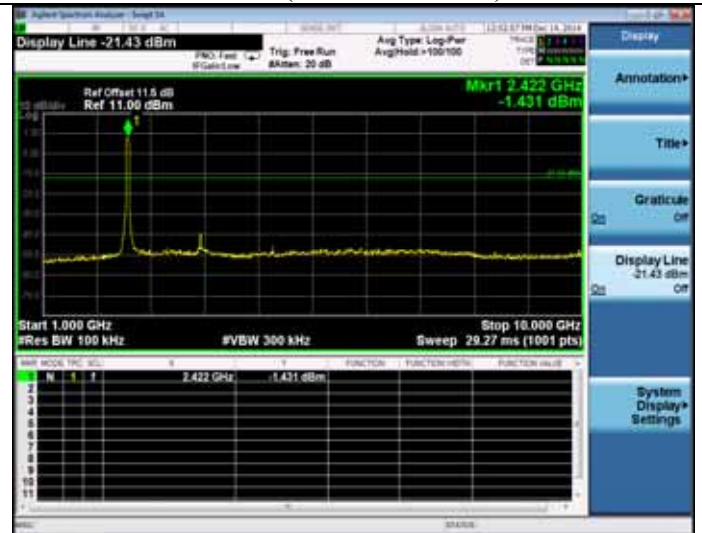

Test CH11: 2462MHz(10GHz – 25GHz)

Test CH1: 2422MHz(2.31GHz – 2.45GHz)

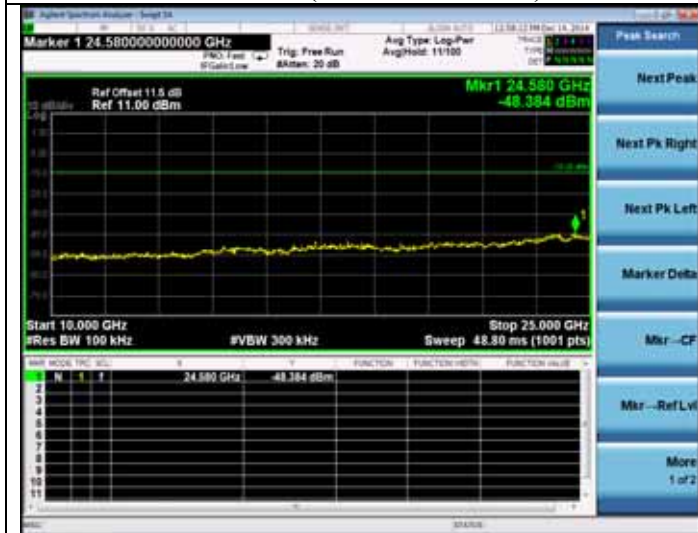

Test CH1: 2422MHz(10GHz – 25GHz)



Test CH4: 2437MHz(10GHz – 25GHz)

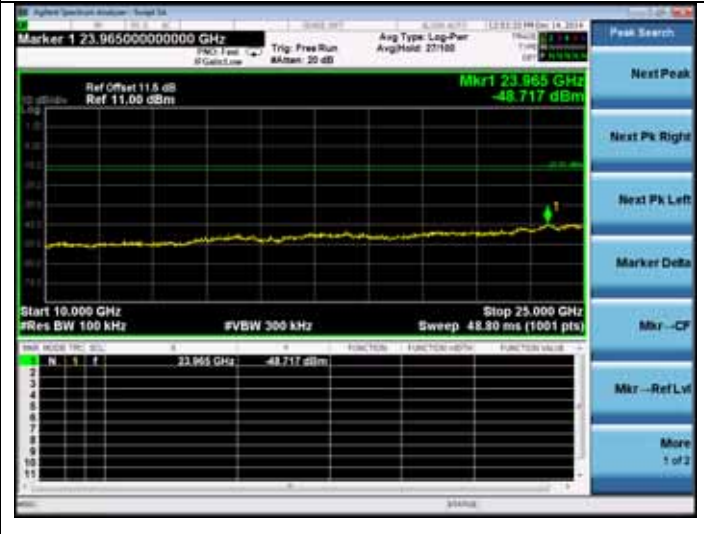

Test CH4: 2437MHz(30MHz – 1GHz)

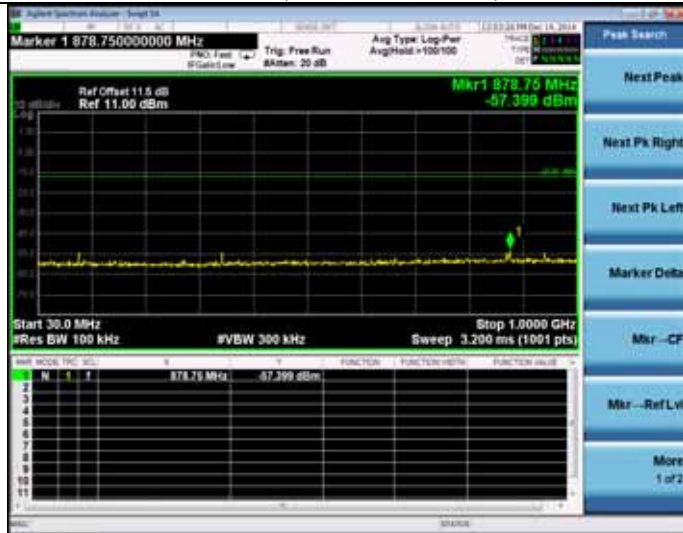

Test CH7: 2452MHz(30MHz – 1GHz)

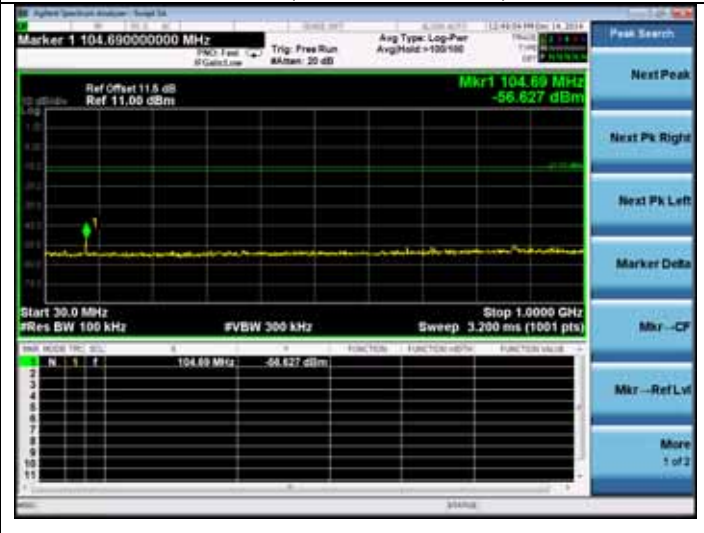

Test CH4: 2437MHz(1GHz – 10GHz)

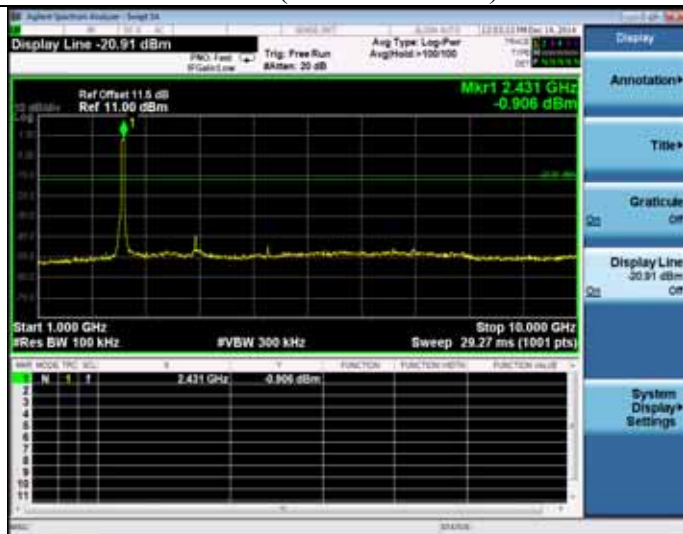

Test CH7: 2452MHz(1GHz – 10GHz)

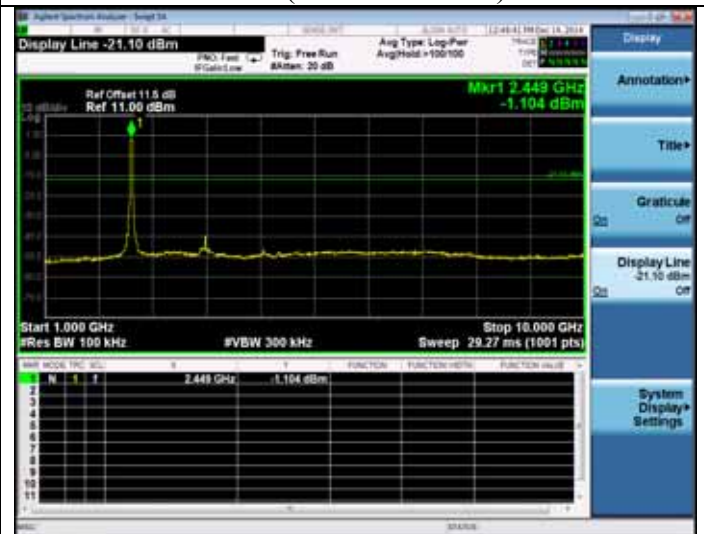

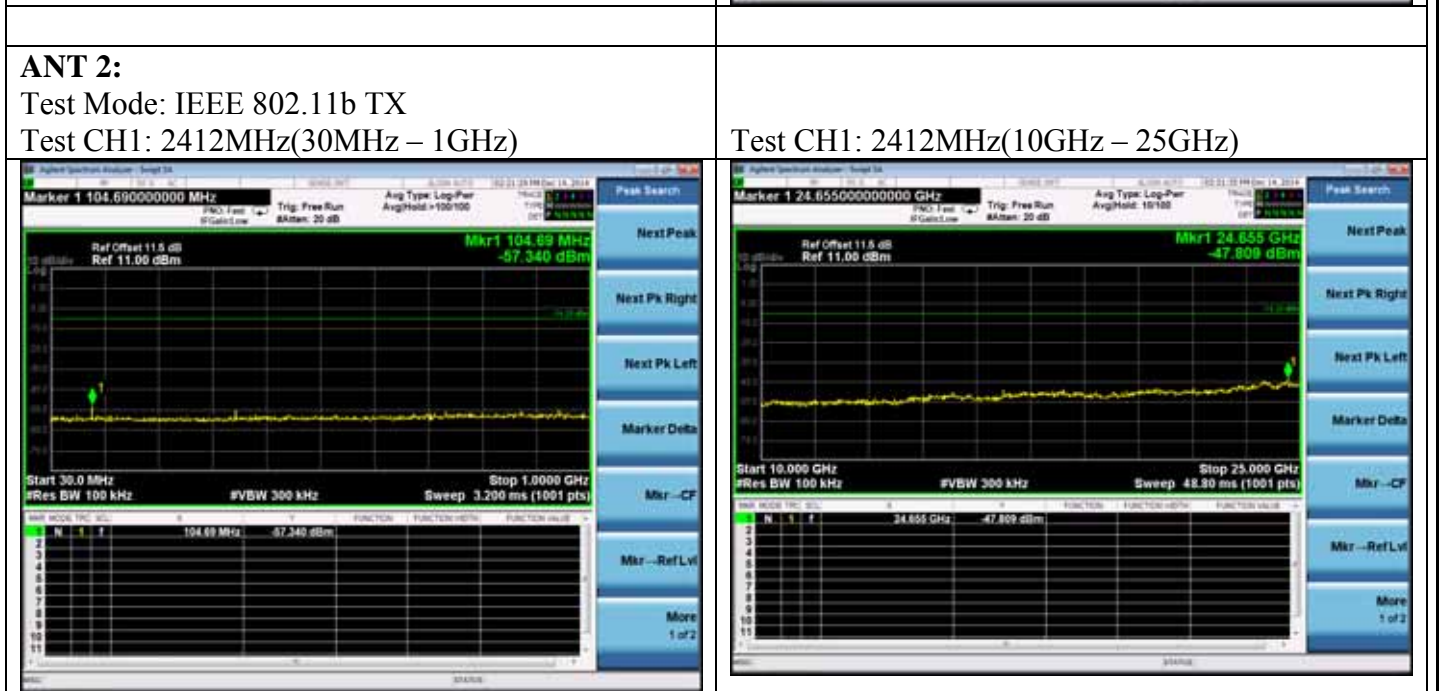
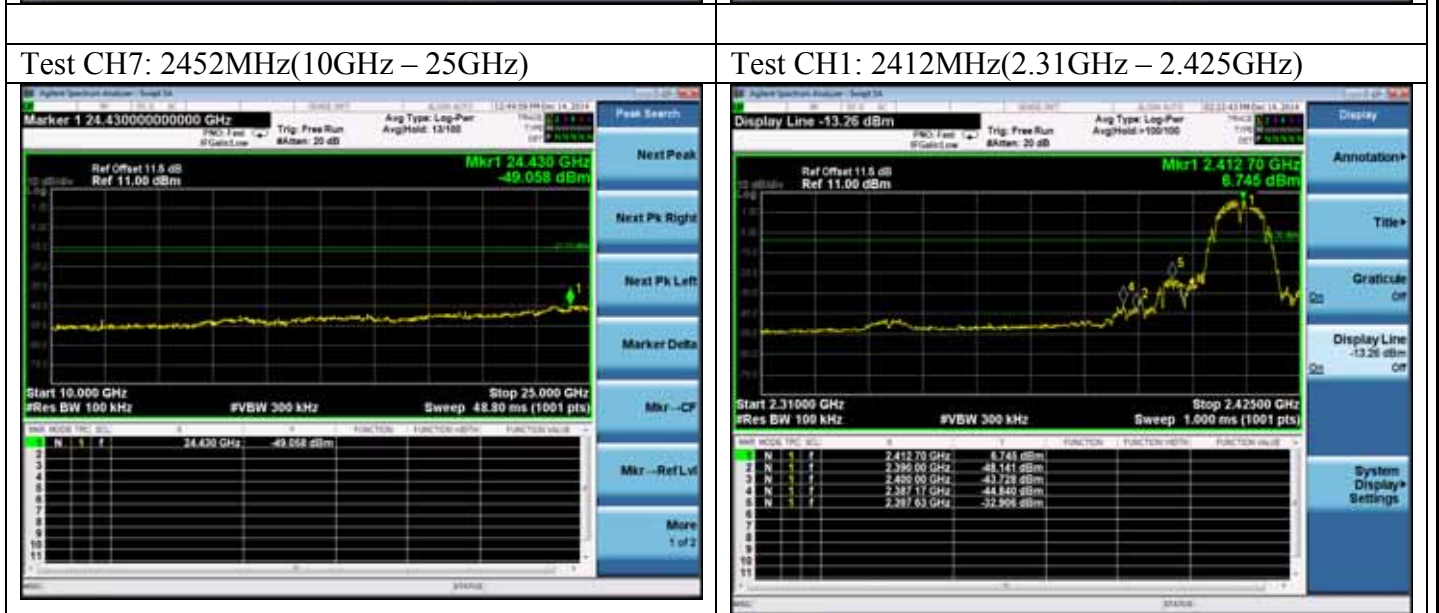
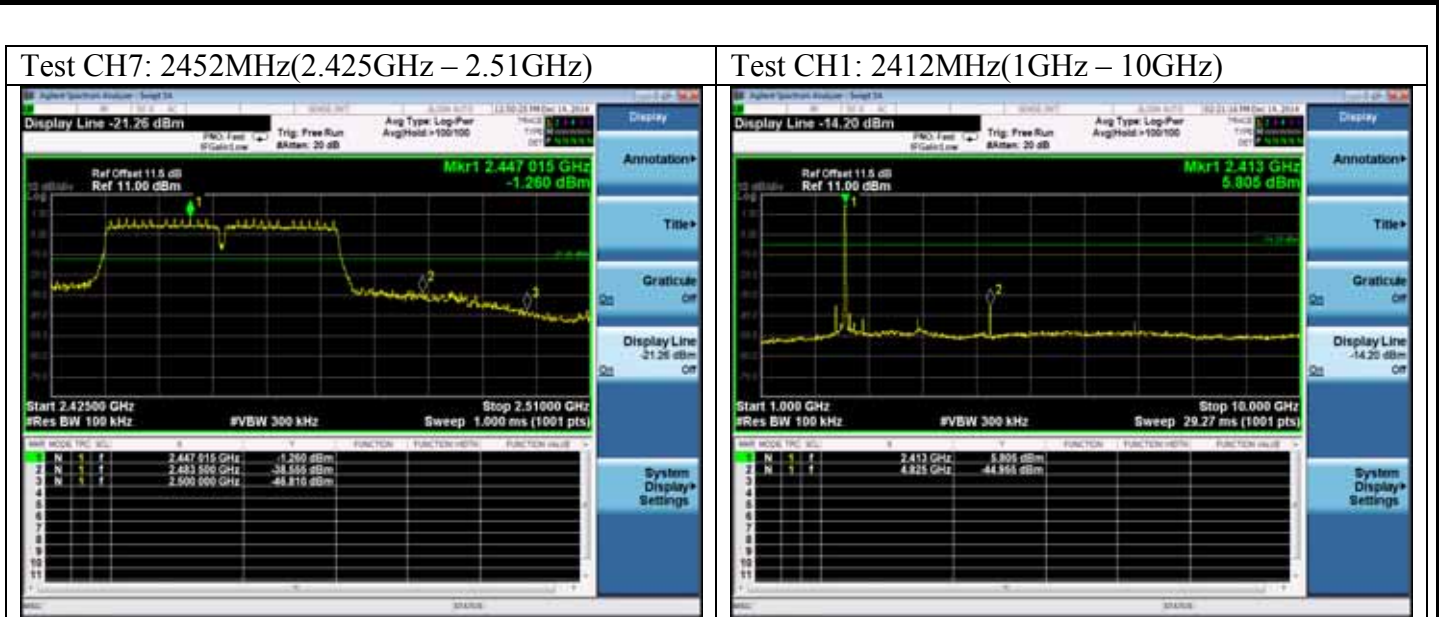

Test CH6: 2437MHz(30MHz – 1GHz)

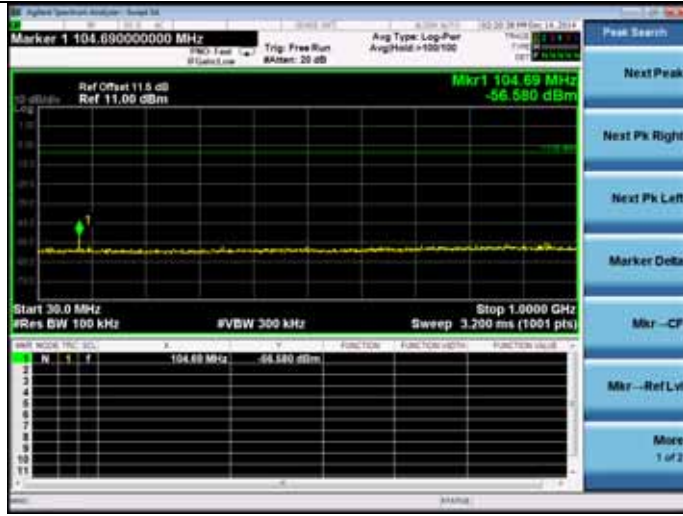

Test CH11: 2462MHz(30MHz – 1GHz)

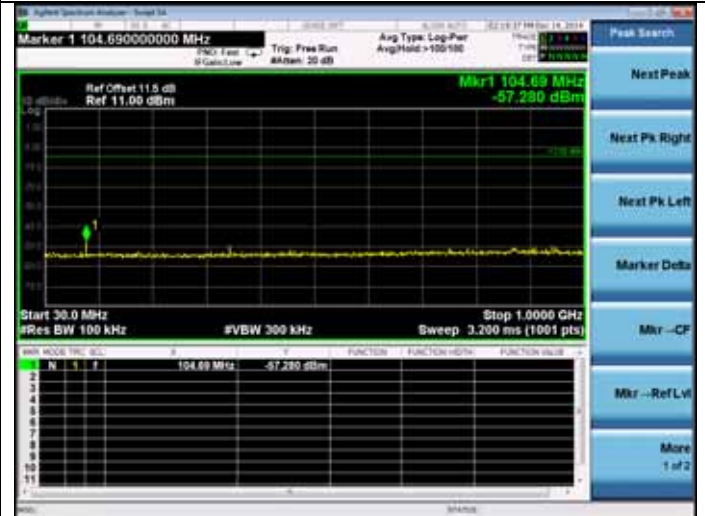

Test CH6: 2437MHz(1GHz – 10GHz)

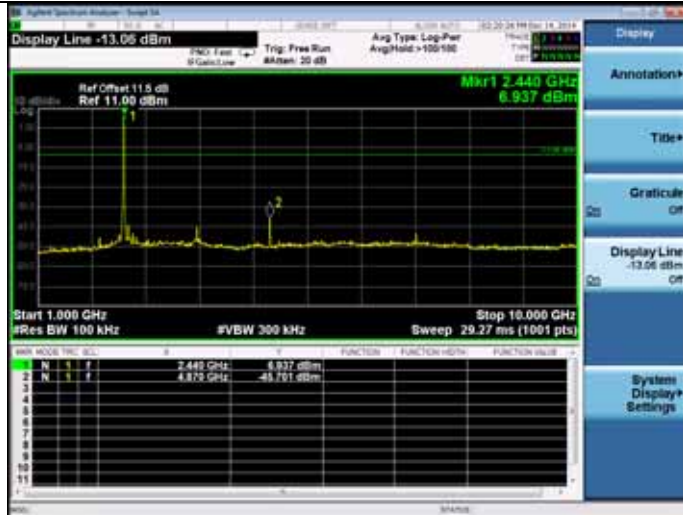

Test CH11: 2462MHz(1GHz – 10GHz)

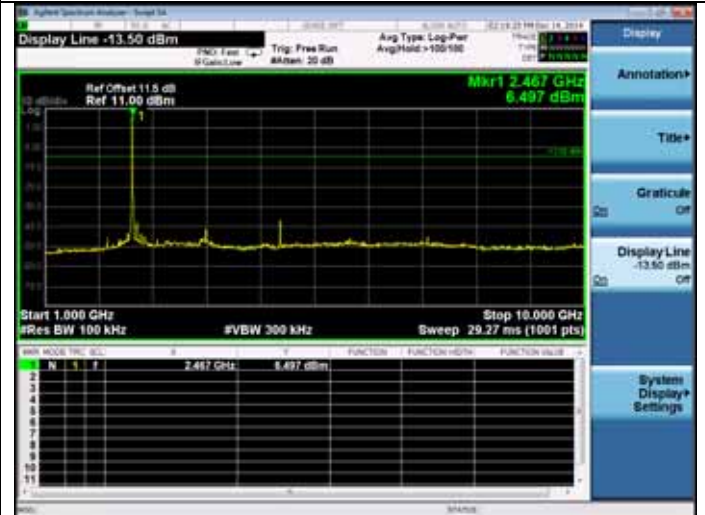

Test CH6: 2437MHz(10GHz – 25GHz)



Test CH11: 2462MHz(2.425GHz – 2.5GHz)



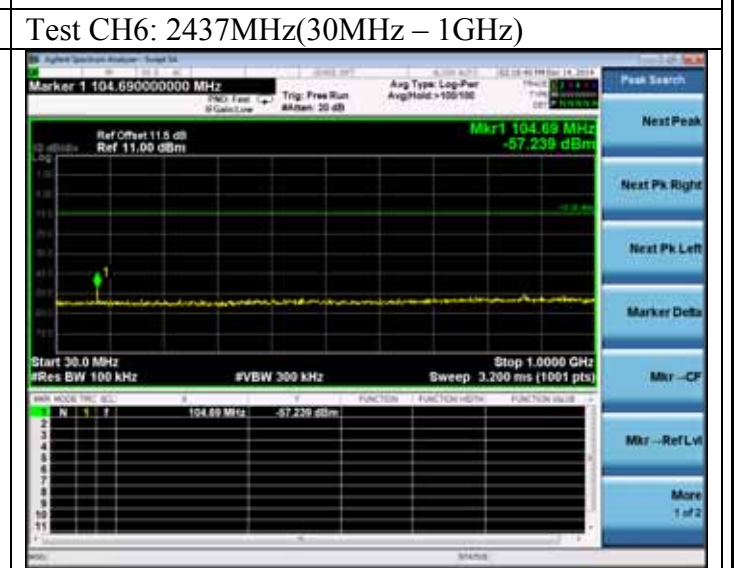
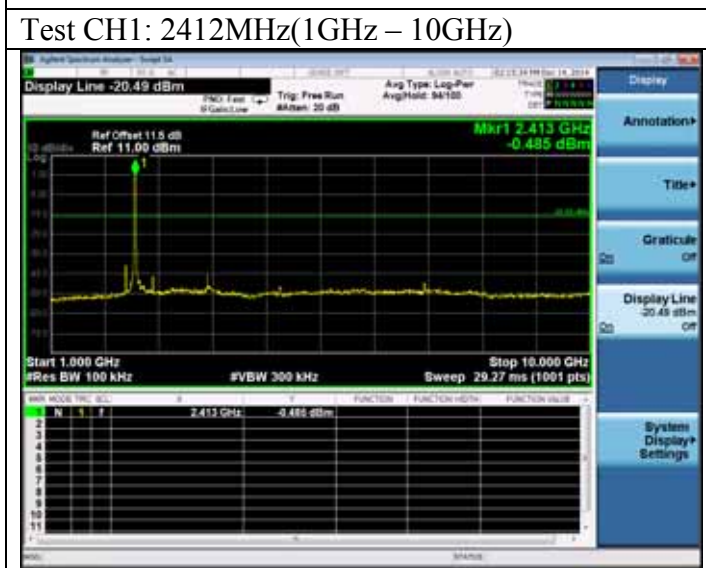
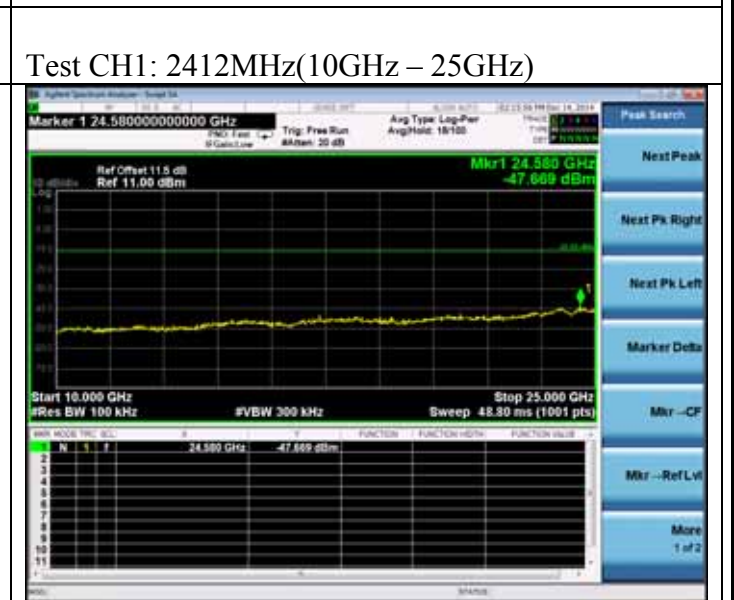
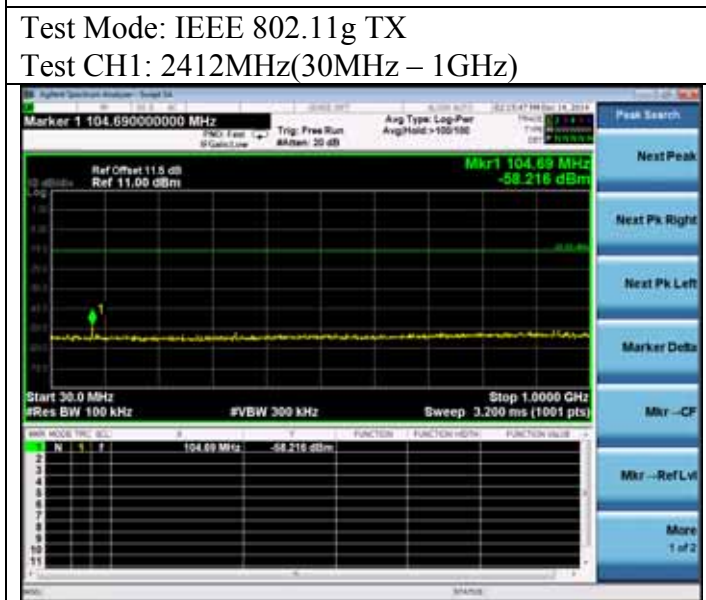
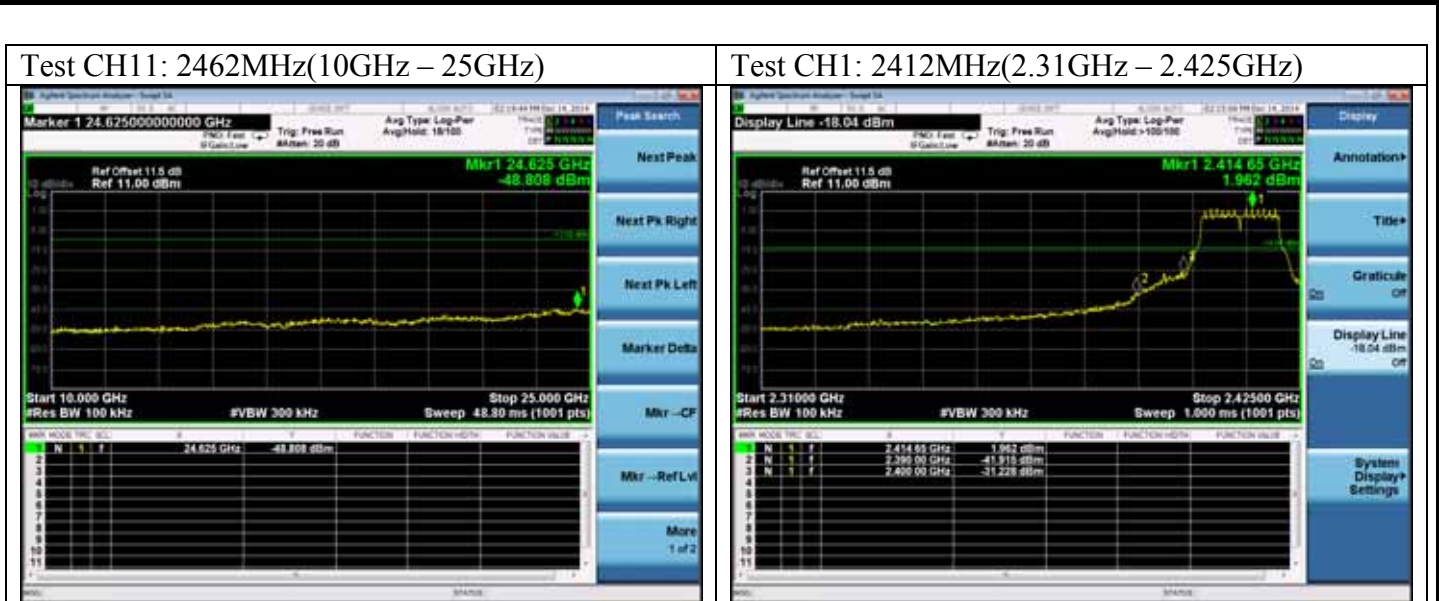

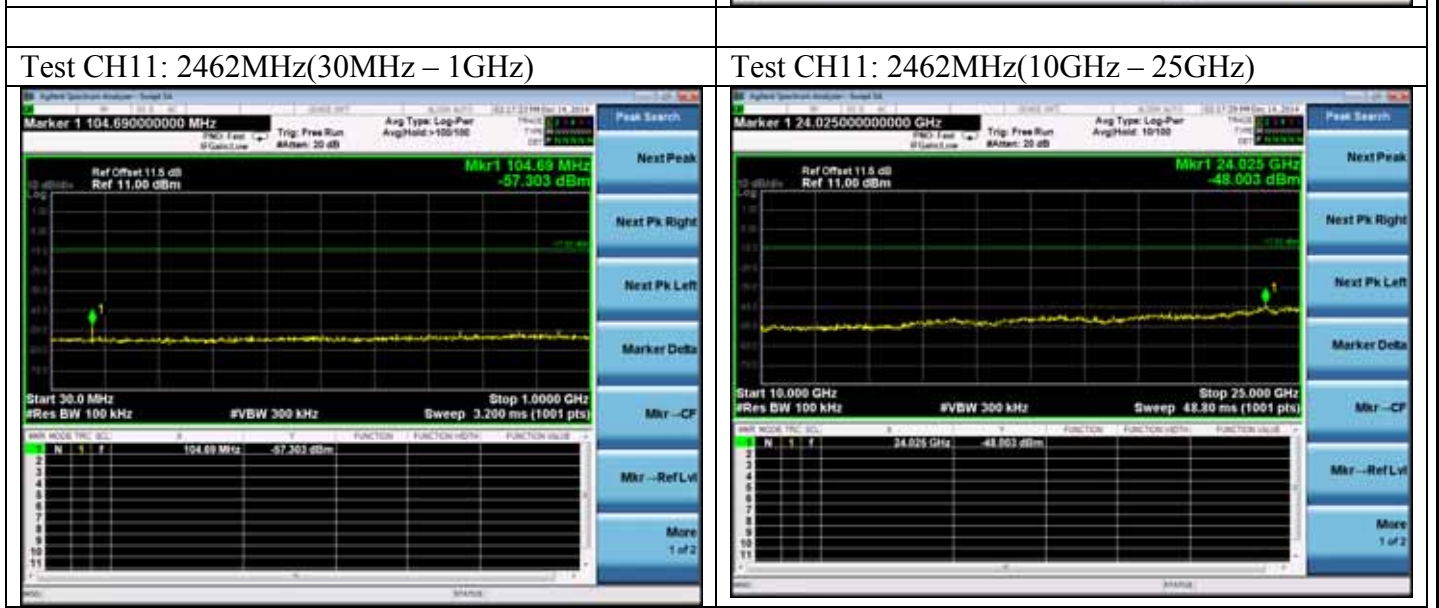
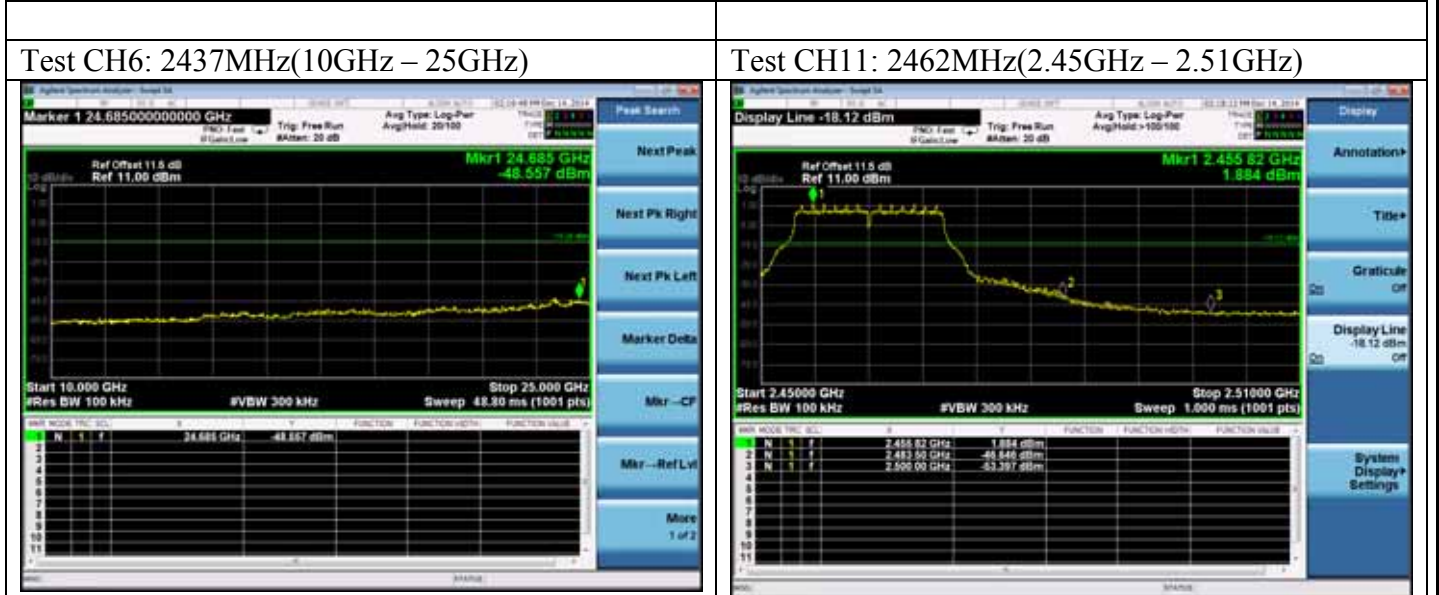
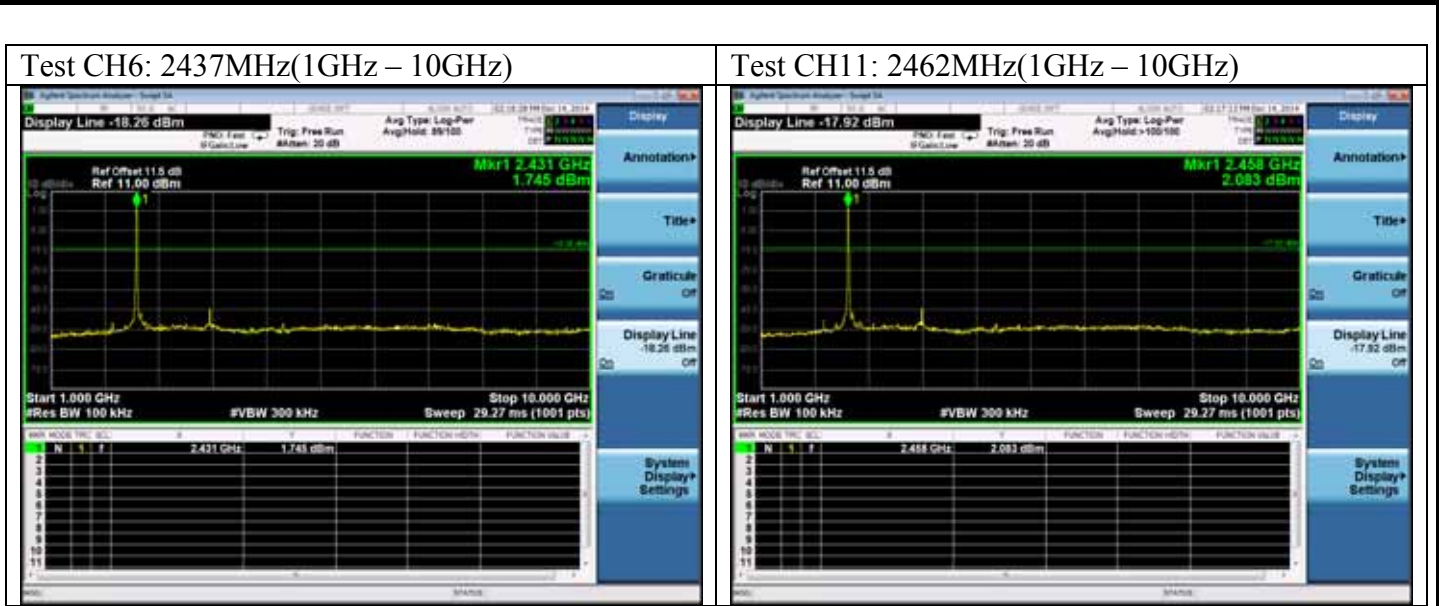



Test Mode: IEEE 802.11n HT20 TX  
 Test CH1: 2412MHz(30MHz – 1GHz)

Test CH1: 2412MHz(10GHz – 25GHz)

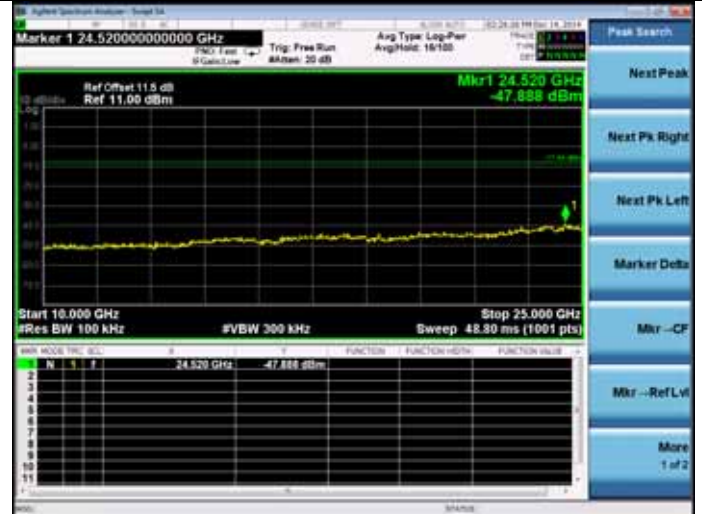
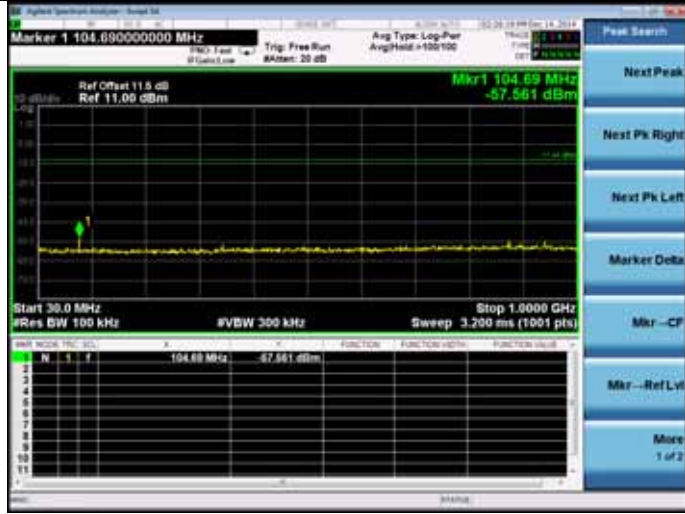

Test CH1: 2412MHz(1GHz – 10GHz)

Test CH6: 2437MHz(30MHz – 1GHz)

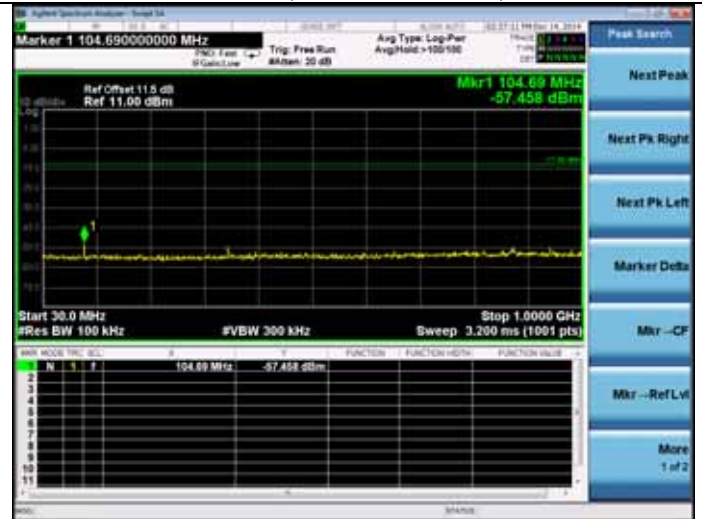
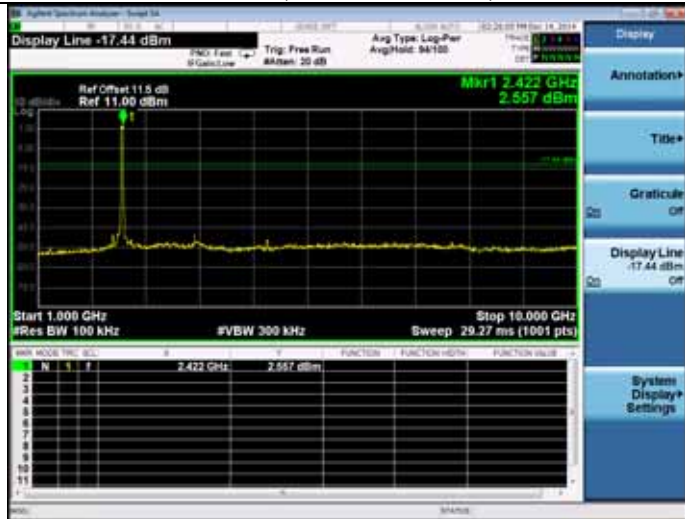

Test CH1: 2412MHz(2.31GHz – 2.425GHz)

Test CH6: 2437MHz(1GHz – 10GHz)

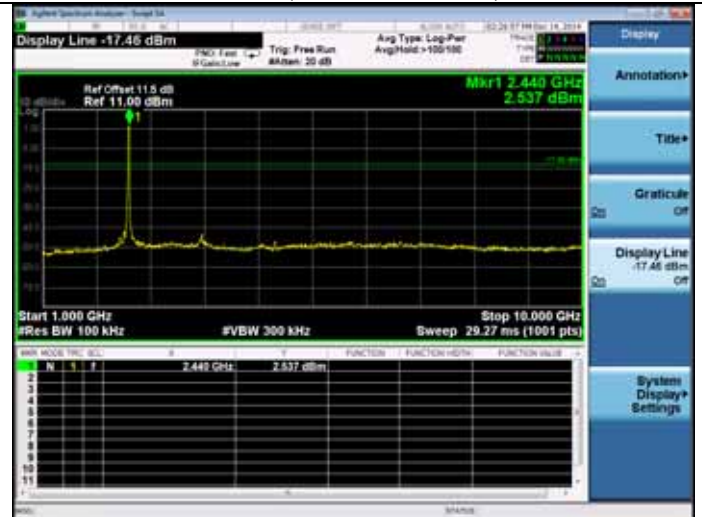

Test CH6: 2437MHz(10GHz – 25GHz)

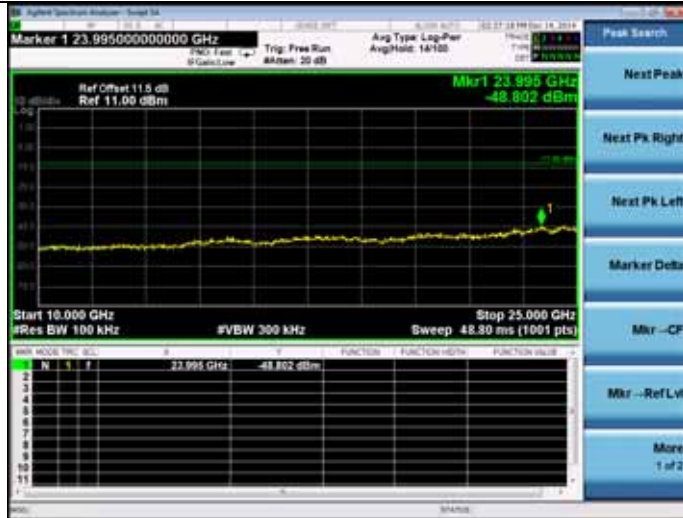

Test CH11: 2462MHz(2.45GHz – 2.51GHz)



Test CH11: 2462MHz(30MHz – 1GHz)

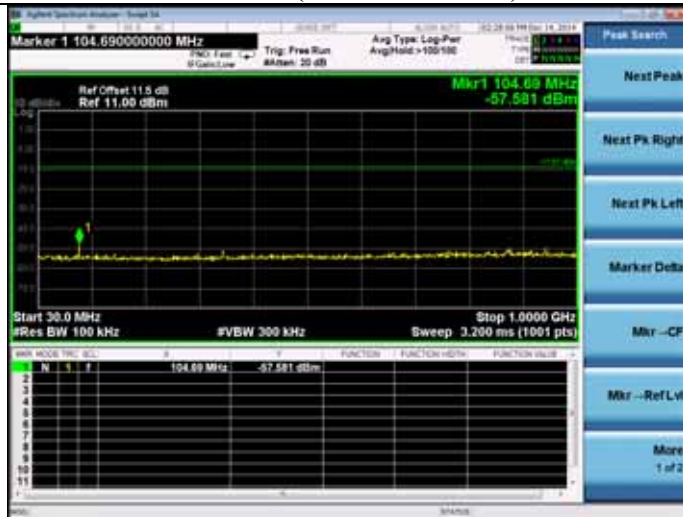

Test CH11: 2462MHz(10GHz – 25GHz)

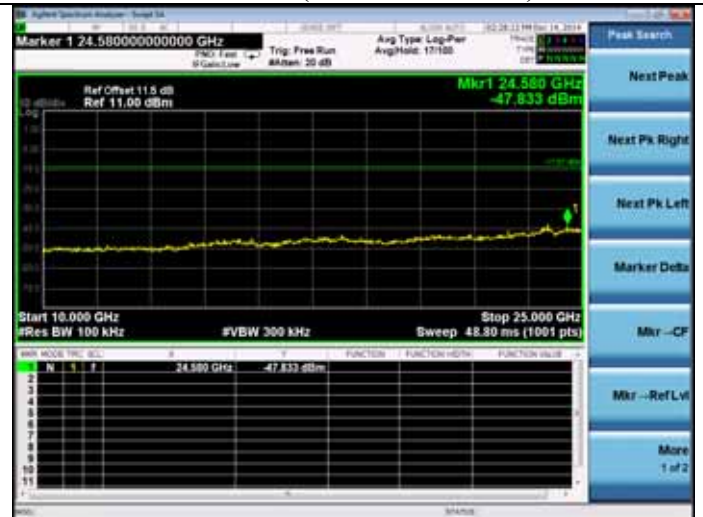

Test CH11: 2462MHz(1GHz – 10GHz)

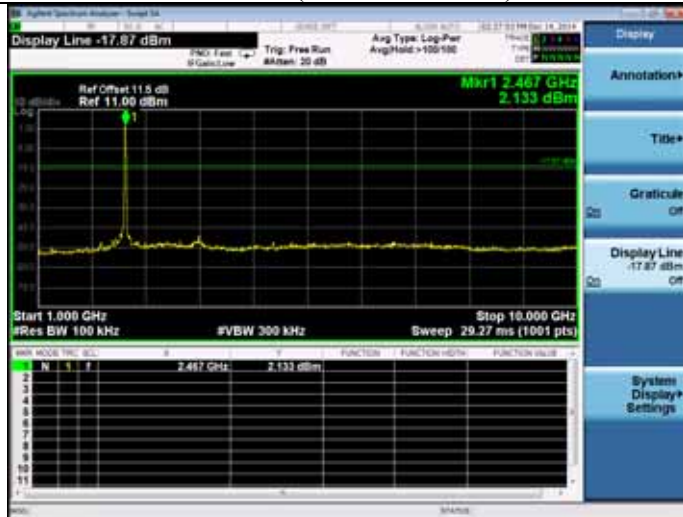

Test Mode: IEEE 802.11n HT40 TX  
Test CH1: 2422MHz(30MHz – 1GHz)

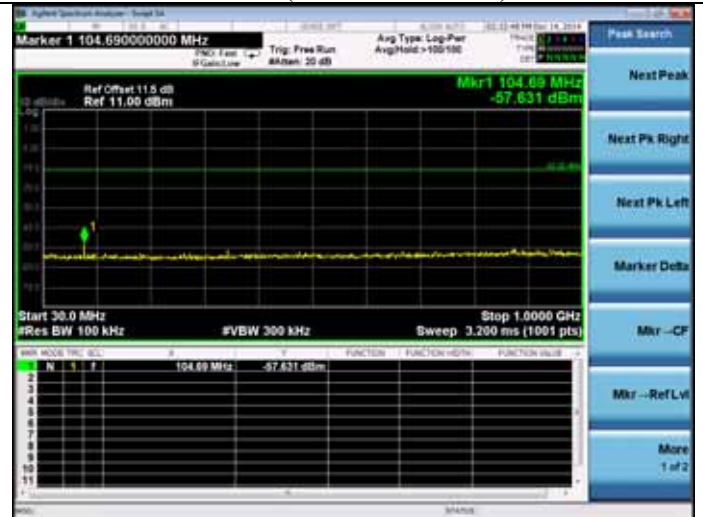



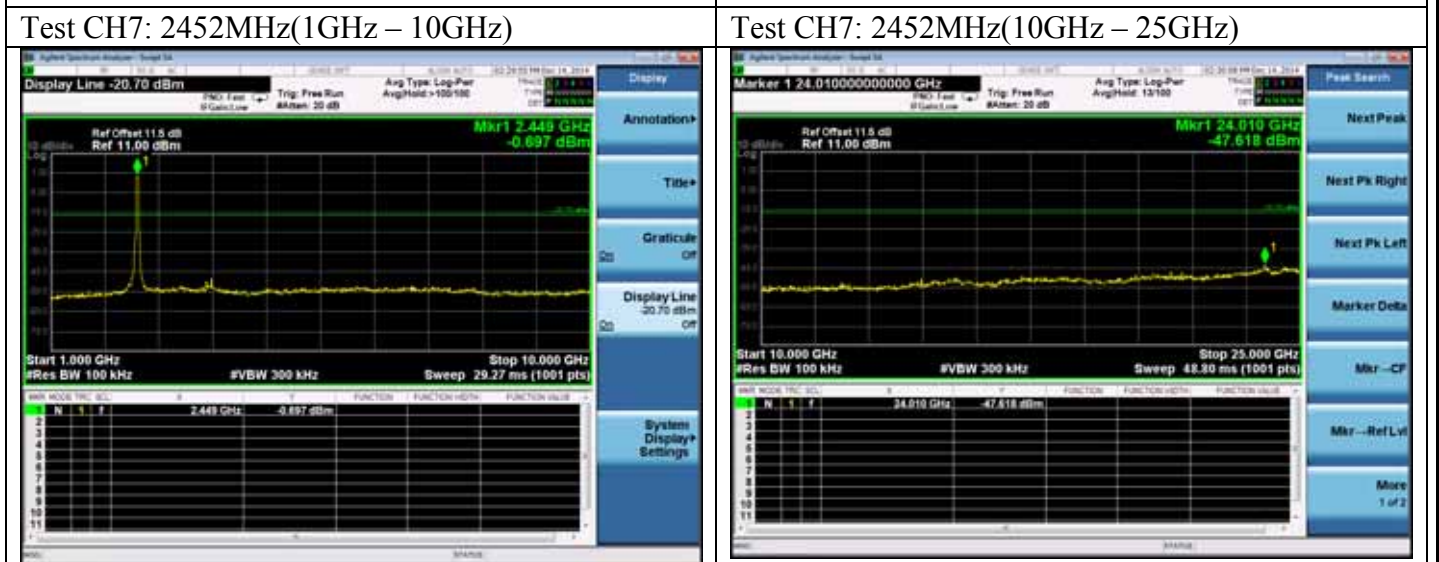
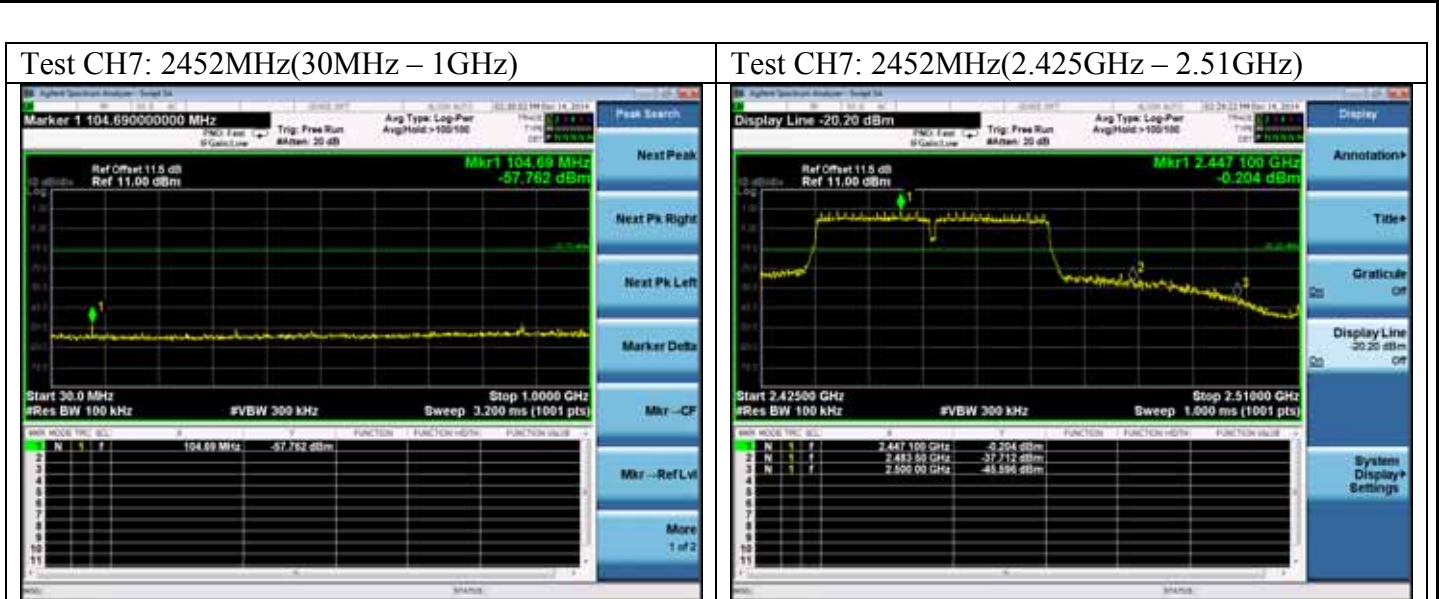

## 6. BAND EDGE COMPLIANCE TEST

### 6.1. Test Equipment

Item	Equipment	Manufacturer	Model No.	Serial No.	Last Cal.	Cal. Interval
1.	Amp	HP	8449B	3008A02495	Apr. 28,14	1 Year
2.	Horn Antenna	ETS	3115	9510-4580	Jun. 06, 14	1 Year
3.	HF Cable	Hubersuhner	Sucoflex104	274094/4	Apr. 28,14	1 Year
4.	RF Cable	Hubersuhner	Sucoflex102	28610/2	Apr. 28,14	1 Year

### 6.2. Limit

All the lower and upper band-edges emissions appearing within 2310MHz to 2390MHz and 2483.5MHz to 2500MHz restricted frequency bands shall not exceed the limits shown in 15.209, all the other emissions outside operation frequency band 2400MHz to 2483.5MHz shall be at least 20dB below the fundamental emissions, or comply with 15.209 limits.

### 6.3. Test Produce

1. The EUT is placed on a turntable, which is 0.8m above the ground plane and worked at highest radiated power.
2. The turntable was rotated for 360 degrees to determine the position of maximum emission level.
3. EUT is set 3m away from the receiving antenna, which is varied from 1m to 4m to find out the highest emission.
4. Set the spectrum analyzer in the following setting in order to capture the lower and upper band-edges of the emission:
  - (a) PEAK: RBW=1MHz; VBW=3MHz; Sweep=AUTO
  - (b) AVERAGE: RBW=1MHz; VBW=10Hz; Sweep=AUTO

### 6.4. Test Results

Pass (The testing data was attached in the next pages.)

**Test Mode: IEEE 802.11b**

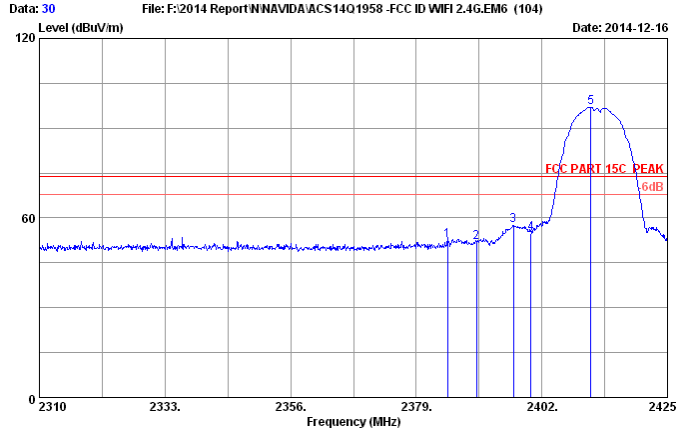
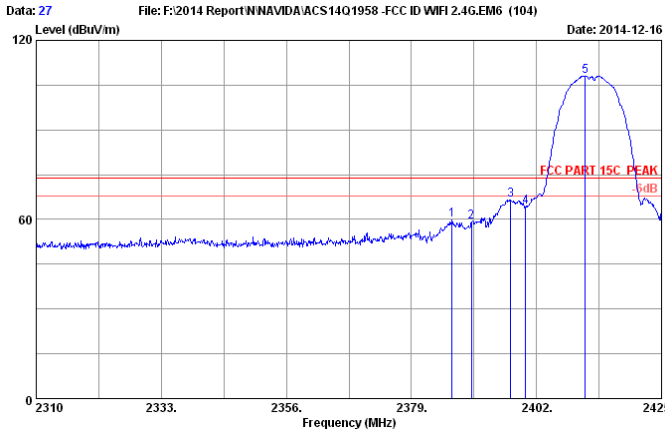

Site no. : 3m Chamber Data no. : 27  
 Dis. / Ant. : 3m 2014 3115 (4580) Ant. pol. : HORIZONTAL  
 Limit : FCC PART 15C PEAK  
 Env. / Ins. : 23°C/54%  
 Engineer : Kobe-Huang  
 EUT : Complex Set-Top Box  
 Power rating : DC 19V From Adpater Input AC 120V/60Hz  
 Test Mode : IEEE802.11b 2412MHz Tx Mode  
 M/N : P2571

Site no. : 3m Chamber Data no. : 30  
 Dis. / Ant. : 3m 2014 3115 (4580) Ant. pol. : VERTICAL  
 Limit : FCC PART 15C PEAK  
 Env. / Ins. : 23°C/54%  
 Engineer : Kobe-Huang  
 EUT : Complex Set-Top Box  
 Power rating : DC 19V From Adpater Input AC 120V/60Hz  
 Test Mode : IEEE802.11b 2412MHz Tx Mode  
 M/N : P2571

No.	Freq. (MHz)	Ant. Factor (dB/m)	Cable Loss (dB)	AMP factor (dB)	Reading (dBuV)	Emission Level (dBuV/m)	Limits (dBuV/m)	Margin (dB)	Remark
1	2386.475	28.15	5.78	35.70	61.50	59.73	74.00	14.27	Peak
2	2390.000	28.16	5.78	35.70	61.08	59.32	74.00	14.68	Peak
3	2397.285	28.17	5.79	35.70	68.30	66.56	74.00	7.44	Peak
4	2400.000	28.18	5.80	35.70	66.03	64.31	74.00	9.69	Peak
5	2410.970	28.20	5.81	35.70	109.80	108.11	74.00	-34.11	Peak

No.	Freq. (MHz)	Ant. Factor (dB/m)	Cable Loss (dB)	AMP factor (dB)	Reading (dBuV)	Emission Level (dBuV/m)	Limits (dBuV/m)	Margin (dB)	Remark
1	2384.750	28.15	5.77	35.70	54.20	52.42	74.00	21.58	Peak
2	2390.000	28.16	5.78	35.70	53.61	51.85	74.00	22.15	Peak
3	2396.825	28.17	5.79	35.70	59.29	57.55	74.00	16.45	Peak
4	2400.000	28.18	5.80	35.70	56.59	54.87	74.00	19.13	Peak
5	2410.970	28.20	5.81	35.70	98.63	96.94	74.00	-22.94	Peak

Remarks: 1. Emission Level= Antenna Factor + Cable Loss + Reading -Amp Factor  
 2. The emission levels that are 20dB below the official limit are not reported.

Remarks: 1. Emission Level= Antenna Factor + Cable Loss + Reading -Amp Factor  
 2. The emission levels that are 20dB below the official limit are not reported.

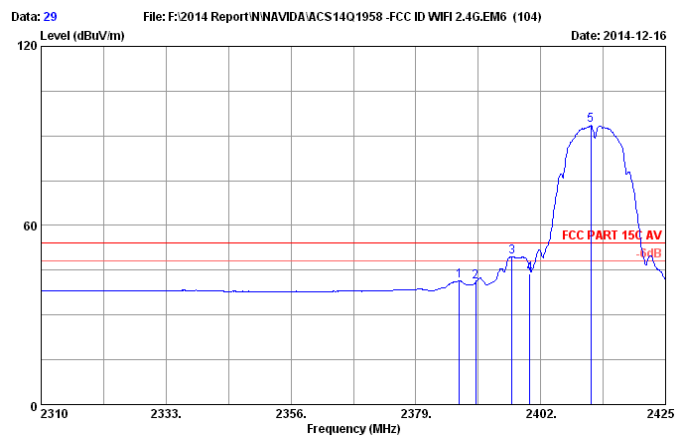
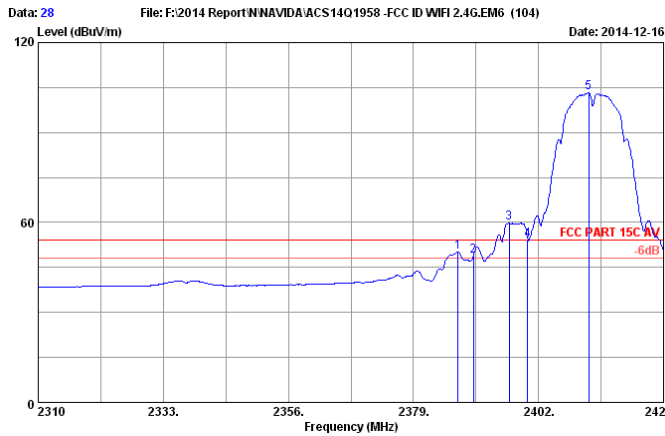

Site no. : 3m Chamber Data no. : 28  
 Dis. / Ant. : 3m 2014 3115 (4580) Ant. pol. : HORIZONTAL  
 Limit : FCC PART 15C AV  
 Env. / Ins. : 23°C/54%  
 Engineer : Kobe-Huang  
 EUT : Complex Set-Top Box  
 Power rating : DC 19V From Adpater Input AC 120V/60Hz  
 Test Mode : IEEE802.11b 2412MHz Tx Mode  
 M/N : P2571

Site no. : 3m Chamber Data no. : 29  
 Dis. / Ant. : 3m 2014 3115 (4580) Ant. pol. : VERTICAL  
 Limit : FCC PART 15C AV  
 Env. / Ins. : 23°C/54%  
 Engineer : Kobe-Huang  
 EUT : Complex Set-Top Box  
 Power rating : DC 19V From Adpater Input AC 120V/60Hz  
 Test Mode : IEEE802.11b 2412MHz Tx Mode  
 M/N : P2571

No.	Freq. (MHz)	Ant. Factor (dB/m)	Cable Loss (dB)	AMP factor (dB)	Reading (dBuV)	Emission Level (dBuV/m)	Limits (dBuV/m)	Margin (dB)	Remark
1	2387.165	28.15	5.78	35.70	52.00	50.23	54.00	3.77	Average
2	2390.000	28.16	5.78	35.70	50.66	48.90	54.00	5.10	Average
3	2396.595	28.17	5.79	35.70	61.53	59.79	54.00	-5.79	Average
4	2400.000	28.18	5.80	35.70	55.89	54.17	54.00	-0.17	Average
5	2411.200	28.20	5.81	35.70	104.96	103.27	54.00	-49.27	Average

No.	Freq. (MHz)	Ant. Factor (dB/m)	Cable Loss (dB)	AMP factor (dB)	Reading (dBuV)	Emission Level (dBuV/m)	Limits (dBuV/m)	Margin (dB)	Remark
1	2387.050	28.15	5.78	35.70	43.21	41.44	54.00	12.56	Average
2	2390.000	28.16	5.78	35.70	42.72	40.96	54.00	13.04	Average
3	2396.710	28.17	5.79	35.70	51.18	49.44	54.00	4.56	Average
4	2400.000	28.18	5.80	35.70	45.55	43.83	54.00	10.17	Average
5	2411.200	28.20	5.81	35.70	95.14	93.45	54.00	-39.45	Average

Remarks: 1. Emission Level= Antenna Factor + Cable Loss + Reading -Amp Factor  
 2. The emission levels that are 20dB below the official limit are not reported.

Remarks: 1. Emission Level= Antenna Factor + Cable Loss + Reading -Amp Factor  
 2. The emission levels that are 20dB below the official limit are not reported.

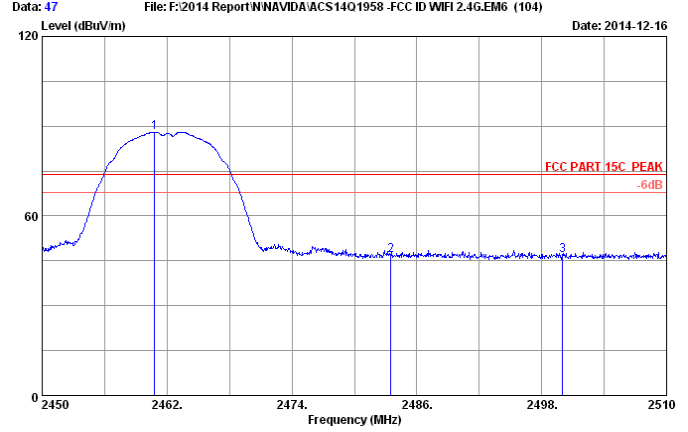
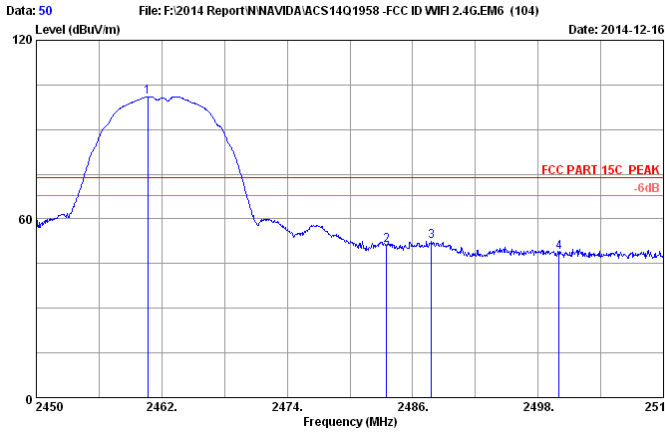

Site no. : 3m Chamber Data no. : 50  
 Dis. / Ant. : 3m 2014 3115 (4580) Ant. pol. : HORIZONTAL  
 Limit : FCC PART 15C PEAK  
 Env. / Ins. : 23°C/54%  
 Engineer : Kobe-Huang  
 EUT : Complex Set-Top Box  
 Power rating : DC 19V From Adppter Input AC 120V/60Hz  
 Test Mode : IEEE802.11b 2462MHz Tx Mode  
 M/N : P2571

Site no. : 3m Chamber Data no. : 47  
 Dis. / Ant. : 3m 2014 3115 (4580) Ant. pol. : VERTICAL  
 Limit : FCC PART 15C PEAK  
 Env. / Ins. : 23°C/54%  
 Engineer : Kobe-Huang  
 EUT : Complex Set-Top Box  
 Power rating : DC 19V From Adppter Input AC 120V/60Hz  
 Test Mode : IEEE802.11b 2462MHz Tx Mode  
 M/N : P2571

No.	Freq. (MHz)	Ant. Factor (dB/m)	Cable Loss (dB)	AMP factor (dB)	Reading (dBuV)	Emission Level (dBuV/m)	Limits (dBuV/m)	Margin (dB)	Remark
1	2460.680	28.31	5.89	35.70	102.53	101.03	74.00	-27.03	Peak
2	2483.500	28.36	5.92	35.70	52.69	51.27	74.00	22.73	Peak
3	2487.800	28.37	5.92	35.70	53.73	52.32	74.00	21.68	Peak
4	2500.000	28.40	5.94	35.70	50.28	48.92	74.00	25.08	Peak

No.	Freq. (MHz)	Ant. Factor (dB/m)	Cable Loss (dB)	AMP factor (dB)	Reading (dBuV)	Emission Level (dBuV/m)	Limits (dBuV/m)	Margin (dB)	Remark
1	2460.800	28.31	5.89	35.70	89.55	88.05	74.00	-14.05	Peak
2	2483.500	28.36	5.92	35.70	48.07	46.65	74.00	27.35	Peak
3	2500.000	28.40	5.94	35.70	48.29	46.93	74.00	27.07	Peak

Remarks: 1. Emission Level= Antenna Factor + Cable Loss + Reading -Amp Factor  
 2. The emission levels that are 20dB below the official limit are not reported.

Remarks: 1. Emission Level= Antenna Factor + Cable Loss + Reading -Amp Factor  
 2. The emission levels that are 20dB below the official limit are not reported.

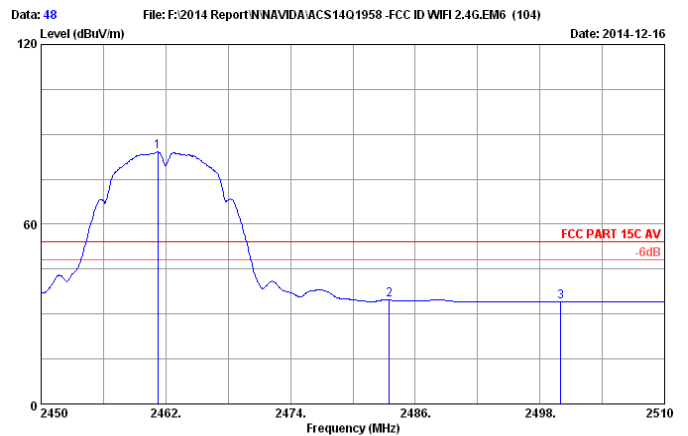
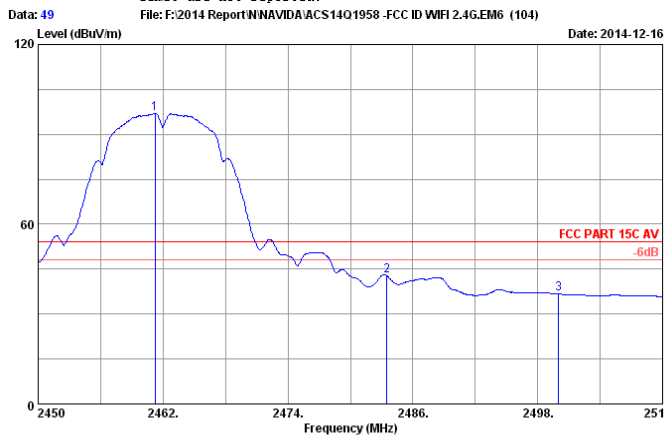

Site no. : 3m Chamber Data no. : 49  
 Dis. / Ant. : 3m 2014 3115 (4580) Ant. pol. : HORIZONTAL  
 Limit : FCC PART 15C AV  
 Env. / Ins. : 23°C/54%  
 Engineer : Kobe-Huang  
 EUT : Complex Set-Top Box  
 Power rating : DC 19V From Adppter Input AC 120V/60Hz  
 Test Mode : IEEE802.11b 2462MHz Tx Mode  
 M/N : P2571

Site no. : 3m Chamber Data no. : 48  
 Dis. / Ant. : 3m 2014 3115 (4580) Ant. pol. : VERTICAL  
 Limit : FCC PART 15C AV  
 Env. / Ins. : 23°C/54%  
 Engineer : Kobe-Huang  
 EUT : Complex Set-Top Box  
 Power rating : DC 19V From Adppter Input AC 120V/60Hz  
 Test Mode : IEEE802.11b 2462MHz Tx Mode  
 M/N : P2571

No.	Freq. (MHz)	Ant. Factor (dB/m)	Cable Loss (dB)	AMP factor (dB)	Reading (dBuV)	Emission Level (dBuV/m)	Limits (dBuV/m)	Margin (dB)	Remark
1	2461.220	28.31	5.89	35.70	98.55	97.05	54.00	-43.05	Average
2	2483.500	28.36	5.92	35.70	44.35	42.93	54.00	11.07	Average
3	2500.000	28.40	5.94	35.70	38.13	36.77	54.00	17.23	Average

No.	Freq. (MHz)	Ant. Factor (dB/m)	Cable Loss (dB)	AMP factor (dB)	Reading (dBuV)	Emission Level (dBuV/m)	Limits (dBuV/m)	Margin (dB)	Remark
1	2461.220	28.31	5.89	35.70	85.61	84.11	54.00	-30.11	Average
2	2483.500	28.36	5.92	35.70	36.14	34.72	54.00	19.28	Average
3	2500.000	28.40	5.94	35.70	35.55	34.19	54.00	19.81	Average

Remarks: 1. Emission Level= Antenna Factor + Cable Loss + Reading -Amp Factor  
 2. The emission levels that are 20dB below the official limit are not reported.

Remarks: 1. Emission Level= Antenna Factor + Cable Loss + Reading -Amp Factor  
 2. The emission levels that are 20dB below the official limit are not reported.

**Test Mode: IEEE 802.11g**

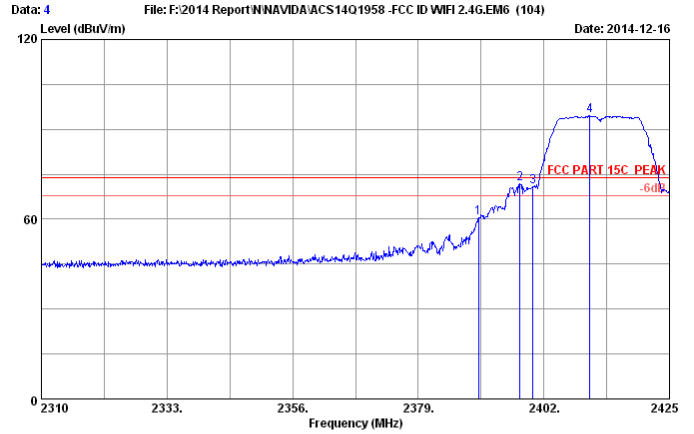
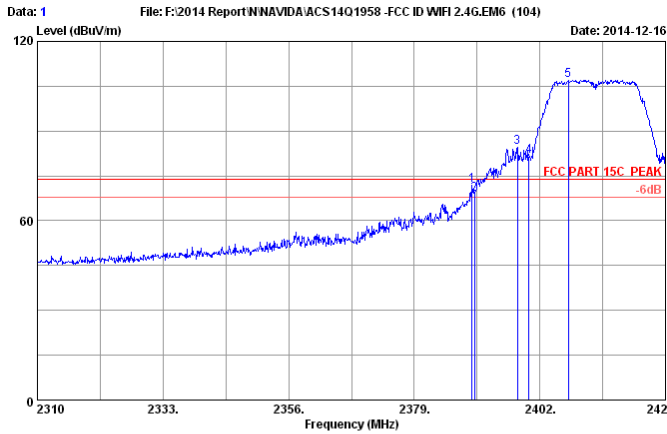

Site no. : 3m Chamber Data no. : 1  
 Dis. / Ant. : 3m 2014 3115 (4580) Ant. pol. : HORIZONTAL  
 Limit : FCC PART 15C PEAK  
 Env. / Ins. : 23°C/54%  
 Engineer : Kobe-Huang  
 EUT : Complex Set-Top Box  
 Power rating : DC 19V From Adppter Input AC 120V/60Hz  
 Test Mode : IEEE802.11g 2412MHz Tx Mode  
 M/N : P2571

Site no. : 3m Chamber Data no. : 4  
 Dis. / Ant. : 3m 2014 3115 (4580) Ant. pol. : VERTICAL  
 Limit : FCC PART 15C PEAK  
 Env. / Ins. : 23°C/54%  
 Engineer : Kobe-Huang  
 EUT : Complex Set-Top Box  
 Power rating : DC 19V From Adppter Input AC 120V/60Hz  
 Test Mode : IEEE802.11g 2412MHz Tx Mode  
 M/N : P2571

No.	Freq. (MHz)	Ant. Factor (dB/m)	Cable Loss (dB)	AMP factor (dB)	Reading (dBuV)	Emission Level (dBuV/m)	Limits (dBuV/m)	Margin (dB)	Remark
1	2389.580	28.16	5.78	35.70	73.58	71.82	74.00	2.18	Peak
2	2390.000	28.16	5.78	35.70	70.61	68.85	74.00	5.15	Peak
3	2397.860	28.18	5.79	35.70	86.27	84.54	74.00	-10.54	Peak
4	2400.000	28.18	5.80	35.70	83.33	81.61	74.00	-7.61	Peak
5	2407.175	28.20	5.81	35.70	108.71	107.02	74.00	-33.02	Peak

No.	Freq. (MHz)	Ant. Factor (dB/m)	Cable Loss (dB)	AMP factor (dB)	Reading (dBuV)	Emission Level (dBuV/m)	Limits (dBuV/m)	Margin (dB)	Remark
1	2390.000	28.16	5.78	35.70	62.17	60.41	74.00	13.59	Peak
2	2397.630	28.17	5.79	35.70	73.46	71.72	74.00	2.28	Peak
3	2400.000	28.18	5.80	35.70	72.58	70.86	74.00	3.14	Peak
4	2410.395	28.20	5.81	35.70	96.16	94.47	74.00	-20.47	Peak

Remarks: 1. Emission Level= Antenna Factor + Cable Loss + Reading -Amp Factor  
 2. The emission levels that are 20dB below the official limit are not reported.

Remarks: 1. Emission Level= Antenna Factor + Cable Loss + Reading -Amp Factor  
 2. The emission levels that are 20dB below the official limit are not reported.

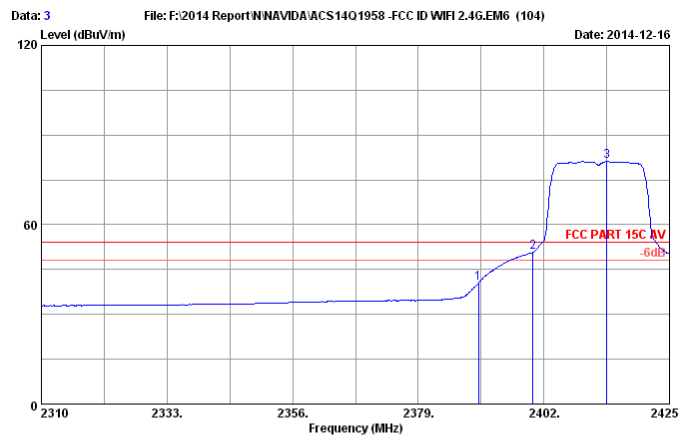
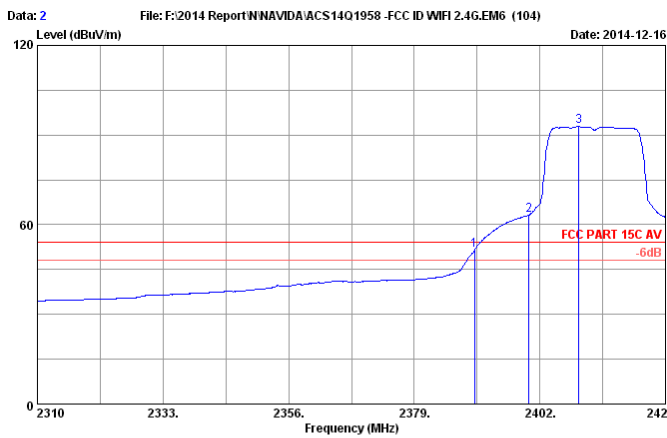

Site no. : 3m Chamber Data no. : 2  
 Dis. / Ant. : 3m 2014 3115 (4580) Ant. pol. : HORIZONTAL  
 Limit : FCC PART 15C AV  
 Env. / Ins. : 23°C/54%  
 Engineer : Kobe-Huang  
 EUT : Complex Set-Top Box  
 Power rating : DC 19V From Adppter Input AC 120V/60Hz  
 Test Mode : IEEE802.11g 2412MHz Tx Mode  
 M/N : P2571

Site no. : 3m Chamber Data no. : 3  
 Dis. / Ant. : 3m 2014 3115 (4580) Ant. pol. : VERTICAL  
 Limit : FCC PART 15C AV  
 Env. / Ins. : 23°C/54%  
 Engineer : Kobe-Huang  
 EUT : Complex Set-Top Box  
 Power rating : DC 19V From Adppter Input AC 120V/60Hz  
 Test Mode : IEEE802.11g 2412MHz Tx Mode  
 M/N : P2571

No.	Freq. (MHz)	Ant. Factor (dB/m)	Cable Loss (dB)	AMP factor (dB)	Reading (dBuV)	Emission Level (dBuV/m)	Limits (dBuV/m)	Margin (dB)	Remark
1	2390.000	28.16	5.78	35.70	53.36	51.60	54.00	2.40	Average
2	2400.000	28.18	5.80	35.70	65.00	63.28	54.00	-9.28	Average
3	2409.130	28.20	5.81	35.70	94.51	92.82	54.00	-38.82	Average

No.	Freq. (MHz)	Ant. Factor (dB/m)	Cable Loss (dB)	AMP factor (dB)	Reading (dBuV)	Emission Level (dBuV/m)	Limits (dBuV/m)	Margin (dB)	Remark
1	2390.000	28.16	5.78	35.70	42.24	40.48	54.00	13.52	Average
2	2400.000	28.18	5.80	35.70	52.52	50.80	54.00	3.20	Average
3	2413.500	28.21	5.82	35.70	82.80	81.13	54.00	-27.13	Average

Remarks: 1. Emission Level= Antenna Factor + Cable Loss + Reading -Amp Factor  
 2. The emission levels that are 20dB below the official limit are not reported.

Remarks: 1. Emission Level= Antenna Factor + Cable Loss + Reading -Amp Factor  
 2. The emission levels that are 20dB below the official limit are not reported.



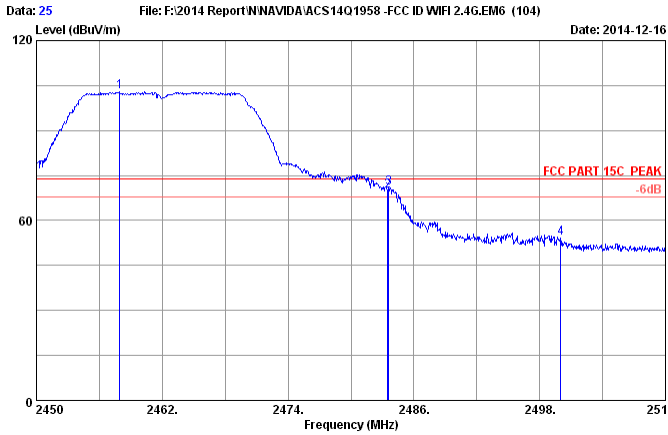

Site no. : 3m Chamber Data no. : 25  
 Dis. / Ant. : 3m 2014 3115 (4580) Ant. pol. : HORIZONTAL  
 Limit : FCC PART 15C PEAK  
 Env. / Ins. : 23°C/54%  
 Engineer : Kobe-Huang  
 EUT : Complex Set-Top Box  
 Power rating : DC 19V From Adppter Input AC 120V/60Hz  
 Test Mode : IEEE802.11g 2462MHz Tx Mode  
 M/N : P2571

No.	Freq. (MHz)	Ant. Factor (dB/m)	Cable Loss (dB)	AMP factor (dB)	Reading (dBuV)	Emission Level (dBuV/m)	Limits (dBuV/m)	Margin (dB)	Remark
1	2457.920	28.31	5.88	35.70	104.36	102.85	74.00	-28.85	Peak
2	2483.500	28.36	5.92	35.70	71.42	70.00	74.00	4.00	Peak
3	2483.600	28.36	5.92	35.70	72.20	70.78	74.00	3.22	Peak
4	2500.000	28.40	5.94	35.70	55.43	54.07	74.00	19.93	Peak

Remarks: 1. Emission Level= Antenna Factor + Cable Loss + Reading - Amp Factor  
 2. The emission levels that are 20dB below the official limit are not reported.

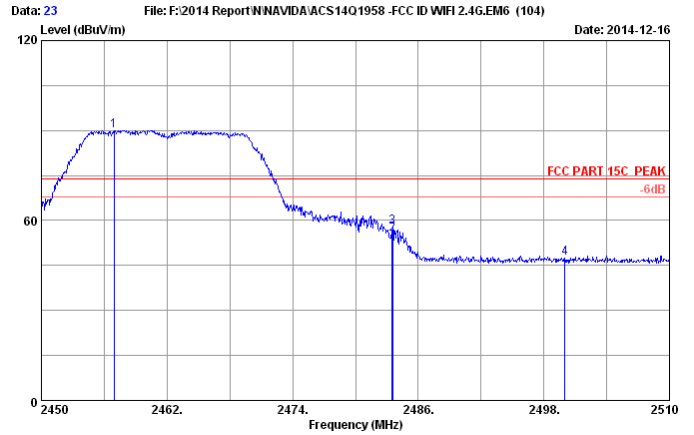

Site no. : 3m Chamber Data no. : 23  
 Dis. / Ant. : 3m 2014 3115 (4580) Ant. pol. : VERTICAL  
 Limit : FCC PART 15C PEAK  
 Env. / Ins. : 23°C/54%  
 Engineer : Kobe-Huang  
 EUT : Complex Set-Top Box  
 Power rating : DC 19V From Adppter Input AC 120V/60Hz  
 Test Mode : IEEE802.11g 2462MHz Tx Mode  
 M/N : P2571

No.	Freq. (MHz)	Ant. Factor (dB/m)	Cable Loss (dB)	AMP factor (dB)	Reading (dBuV)	Emission Level (dBuV/m)	Limits (dBuV/m)	Margin (dB)	Remark
1	2456.960	28.31	5.88	35.70	91.57	90.06	74.00	-16.06	Peak
2	2483.500	28.36	5.92	35.70	57.01	55.59	74.00	18.41	Peak
3	2483.540	28.36	5.92	35.70	59.18	57.76	74.00	16.24	Peak
4	2500.000	28.40	5.94	35.70	48.93	47.57	74.00	26.43	Peak

Remarks: 1. Emission Level= Antenna Factor + Cable Loss + Reading - Amp Factor  
 2. The emission levels that are 20dB below the official limit are not reported.

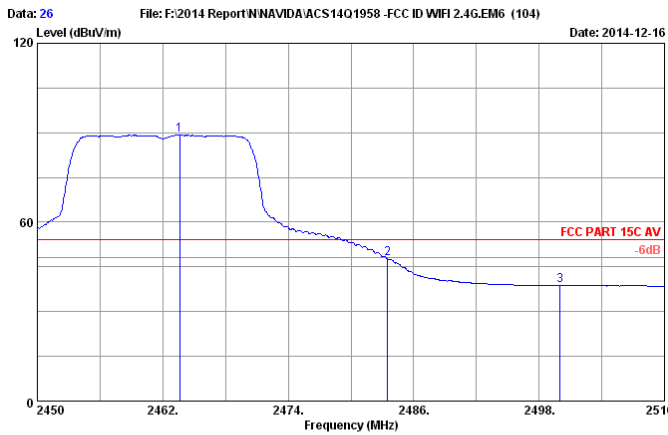

Site no. : 3m Chamber Data no. : 26  
 Dis. / Ant. : 3m 2014 3115 (4580) Ant. pol. : HORIZONTAL  
 Limit : FCC PART 15C AV  
 Env. / Ins. : 23°C/54%  
 Engineer : Kobe-Huang  
 EUT : Complex Set-Top Box  
 Power rating : DC 19V From Adppter Input AC 120V/60Hz  
 Test Mode : IEEE802.11g 2462MHz Tx Mode  
 M/N : P2571

No.	Freq. (MHz)	Ant. Factor (dB/m)	Cable Loss (dB)	AMP factor (dB)	Reading (dBuV)	Emission Level (dBuV/m)	Limits (dBuV/m)	Margin (dB)	Remark
1	2463.620	28.32	5.89	35.70	90.70	89.21	54.00	-35.21	Average
2	2483.500	28.36	5.92	35.70	49.13	47.71	54.00	6.29	Average
3	2500.000	28.40	5.94	35.70	40.12	38.76	54.00	15.24	Average

Remarks: 1. Emission Level= Antenna Factor + Cable Loss + Reading - Amp Factor  
 2. The emission levels that are 20dB below the official limit are not reported.

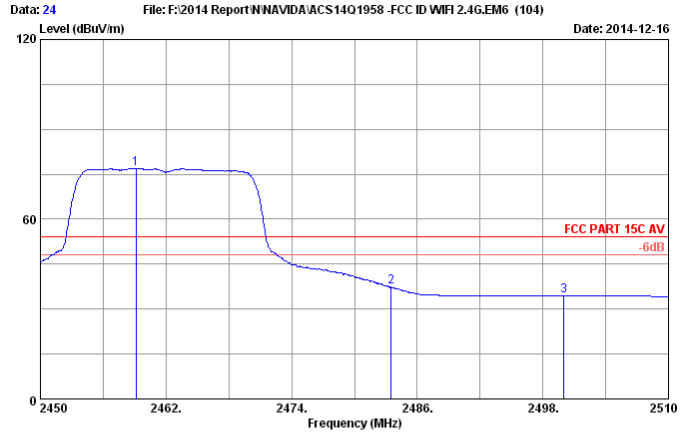

Site no. : 3m Chamber Data no. : 24  
 Dis. / Ant. : 3m 2014 3115 (4580) Ant. pol. : VERTICAL  
 Limit : FCC PART 15C AV  
 Env. / Ins. : 23°C/54%  
 Engineer : Kobe-Huang  
 EUT : Complex Set-Top Box  
 Power rating : DC 19V From Adppter Input AC 120V/60Hz  
 Test Mode : IEEE802.11g 2462MHz Tx Mode  
 M/N : P2571

No.	Freq. (MHz)	Ant. Factor (dB/m)	Cable Loss (dB)	AMP factor (dB)	Reading (dBuV)	Emission Level (dBuV/m)	Limits (dBuV/m)	Margin (dB)	Remark
1	2459.120	28.31	5.88	35.70	78.41	76.90	54.00	-22.90	Average
2	2483.500	28.36	5.92	35.70	38.70	37.28	54.00	16.72	Average
3	2500.000	28.40	5.94	35.70	35.73	34.37	54.00	19.63	Average

Remarks: 1. Emission Level= Antenna Factor + Cable Loss + Reading - Amp Factor  
 2. The emission levels that are 20dB below the official limit are not reported.

**Test Mode: IEEE 802.11n HT20**

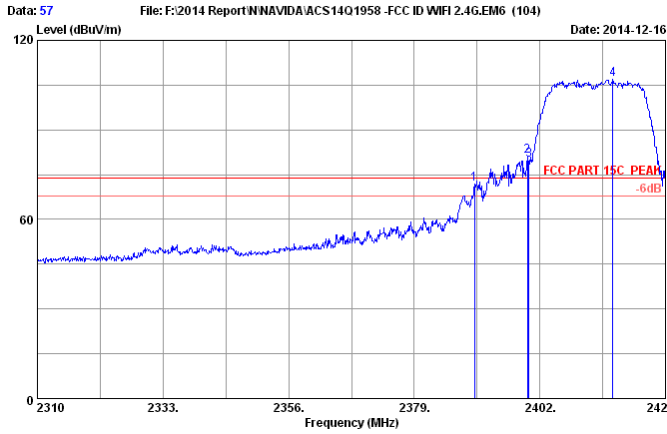

Site no. : 3m Chamber Data no. : 57  
 Dis. / Ant. : 3m 2014 3115 (4580) Ant. pol. : HORIZONTAL  
 Limit : FCC PART 15C PEAK  
 Env. / Ins. : 23°C/54%  
 Engineer : Kobe-Huang  
 EUT : Complex Set-Top Box  
 Power rating : DC 19V From Adppter Input AC 120V/60Hz  
 Test Mode : IEEE802.11nHT20 2412MHz Tx Mode  
 M/N : P2571

No.	Freq. (MHz)	Ant. Factor (dB/m)	Cable Loss (dB)	AMP factor (dB)	Reading (dBuV)	Emission Level (dBuV/m)	Limits (dBuV/m)	Margin (dB)	Remark
1	2390.000	28.16	5.78	35.70	73.74	71.98	74.00	2.02	Peak
2	2399.700	28.18	5.80	35.70	82.83	81.11	74.00	-7.11	Peak
3	2400.000	28.18	5.80	35.70	81.72	80.00	74.00	-6.00	Peak
4	2415.340	28.21	5.82	35.70	108.66	106.99	74.00	-32.99	Peak

Remarks: 1. Emission Level= Antenna Factor + Cable Loss + Reading - Amp Factor  
 2. The emission levels that are 20dB below the official

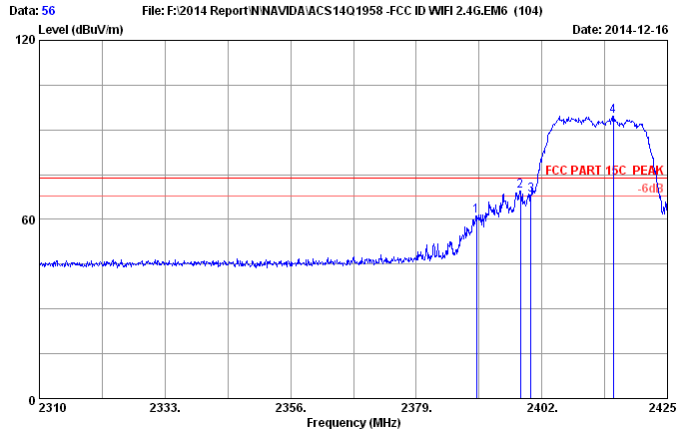

Site no. : 3m Chamber Data no. : 56  
 Dis. / Ant. : 3m 2014 3115 (4580) Ant. pol. : VERTICAL  
 Limit : FCC PART 15C PEAK  
 Env. / Ins. : 23°C/54%  
 Engineer : Kobe-Huang  
 EUT : Complex Set-Top Box  
 Power rating : DC 19V From Adppter Input AC 120V/60Hz  
 Test Mode : IEEE802.11nHT20 2412MHz Tx Mode  
 M/N : P2571

No.	Freq. (MHz)	Ant. Factor (dB/m)	Cable Loss (dB)	AMP factor (dB)	Reading (dBuV)	Emission Level (dBuV/m)	Limits (dBuV/m)	Margin (dB)	Remark
1	2390.000	28.16	5.78	35.70	62.85	61.09	74.00	12.91	Peak
2	2398.090	28.18	5.79	35.70	71.39	69.66	74.00	4.34	Peak
3	2400.000	28.18	5.80	35.70	69.79	68.07	74.00	5.93	Peak
4	2415.110	28.21	5.82	35.70	96.27	94.60	74.00	-20.60	Peak

Remarks: 1. Emission Level= Antenna Factor + Cable Loss + Reading - Amp Factor  
 2. The emission levels that are 20dB below the official

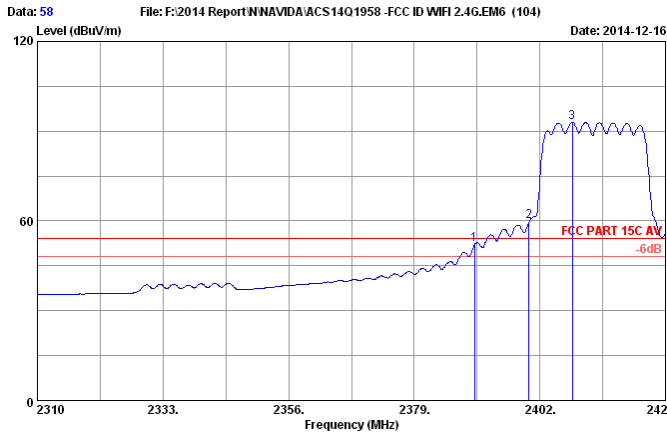

Site no. : 3m Chamber Data no. : 58  
 Dis. / Ant. : 3m 2014 3115 (4580) Ant. pol. : HORIZONTAL  
 Limit : FCC PART 15C AV  
 Env. / Ins. : 23°C/54%  
 Engineer : Kobe-Huang  
 EUT : Complex Set-Top Box  
 Power rating : DC 19V From Adppter Input AC 120V/60Hz  
 Test Mode : IEEE802.11nHT20 2412MHz Tx Mode  
 M/N : P2571

No.	Freq. (MHz)	Ant. Factor (dB/m)	Cable Loss (dB)	AMP factor (dB)	Reading (dBuV)	Emission Level (dBuV/m)	Limits (dBuV/m)	Margin (dB)	Remark
1	2390.000	28.16	5.78	35.70	53.75	51.99	54.00	2.01	Average
2	2400.000	28.18	5.80	35.70	61.44	59.72	54.00	-5.72	Average
3	2407.980	28.20	5.81	35.70	94.65	92.96	54.00	-38.96	Average

Remarks: 1. Emission Level= Antenna Factor + Cable Loss + Reading - Amp Factor  
 2. The emission levels that are 20dB below the official limit are not reported.

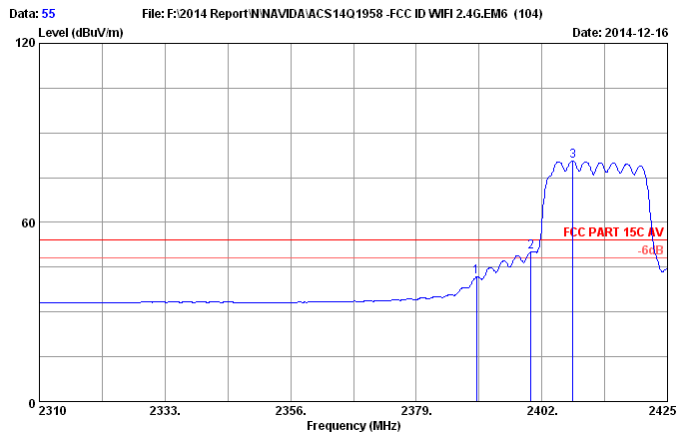

Site no. : 3m Chamber Data no. : 55  
 Dis. / Ant. : 3m 2014 3115 (4580) Ant. pol. : VERTICAL  
 Limit : FCC PART 15C AV  
 Env. / Ins. : 23°C/54%  
 Engineer : Kobe-Huang  
 EUT : Complex Set-Top Box  
 Power rating : DC 19V From Adppter Input AC 120V/60Hz  
 Test Mode : IEEE802.11nHT20 2412MHz Tx Mode  
 M/N : P2571

No.	Freq. (MHz)	Ant. Factor (dB/m)	Cable Loss (dB)	AMP factor (dB)	Reading (dBuV)	Emission Level (dBuV/m)	Limits (dBuV/m)	Margin (dB)	Remark
1	2390.000	28.16	5.78	35.70	43.50	41.74	54.00	12.26	Average
2	2400.000	28.18	5.80	35.70	51.87	50.15	54.00	3.85	Average
3	2407.635	28.20	5.81	35.70	82.26	80.57	54.00	-26.57	Average

Remarks: 1. Emission Level= Antenna Factor + Cable Loss + Reading - Amp Factor  
 2. The emission levels that are 20dB below the official limit are not reported.

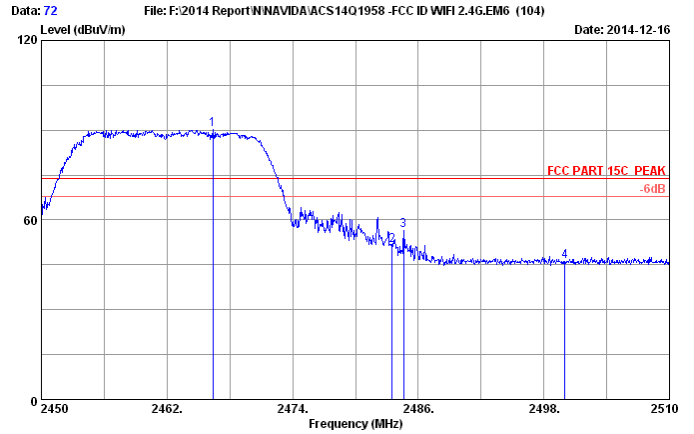
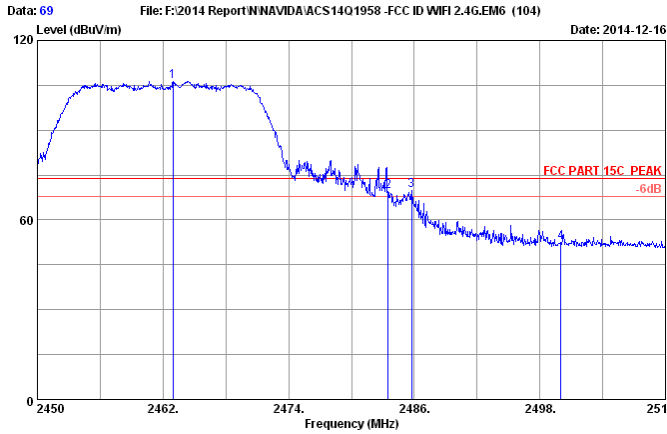

Site no. : 3m Chamber Data no. : 69  
 Dis. / Ant. : 3m 2014 3115 (4580) Ant. pol. : HORIZONTAL  
 Limit : FCC PART 15C PEAK  
 Env. / Ins. : 23°C/54%  
 Engineer : Kobe-Huang  
 EUT : Complex Set-Top Box  
 Power rating : DC 19V From Adppter Input AC 120V/60Hz  
 Test Mode : IEEE802.11nHT20 2462MHz Tx Mode  
 M/N : P2571

Site no. : 3m Chamber Data no. : 72  
 Dis. / Ant. : 3m 2014 3115 (4580) Ant. pol. : VERTICAL  
 Limit : FCC PART 15C PEAK  
 Env. / Ins. : 23°C/54%  
 Engineer : Kobe-Huang  
 EUT : Complex Set-Top Box  
 Power rating : DC 19V From Adppter Input AC 120V/60Hz  
 Test Mode : IEEE802.11nHT20 2462MHz Tx Mode  
 M/N : P2571

No.	Freq. (MHz)	Ant. Factor (dB/m)	Cable Loss (dB)	AMP factor (dB)	Reading (dBuV)	Emission Level (dBuV/m)	Limits (dBuV/m)	Margin (dB)	Remark
1	2462.960	28.32	5.89	35.70	107.81	106.32	74.00	-32.32	Peak
2	2483.500	28.36	5.92	35.70	70.80	69.36	74.00	4.62	Peak
3	2485.760	28.37	5.92	35.70	71.32	69.91	74.00	4.09	Peak
4	2500.000	28.40	5.94	35.70	53.70	52.34	74.00	21.66	Peak

No.	Freq. (MHz)	Ant. Factor (dB/m)	Cable Loss (dB)	AMP factor (dB)	Reading (dBuV)	Emission Level (dBuV/m)	Limits (dBuV/m)	Margin (dB)	Remark
1	2466.380	28.33	5.89	35.70	91.82	90.34	74.00	-16.34	Peak
2	2483.500	28.36	5.92	35.70	52.90	51.48	74.00	22.52	Peak
3	2484.620	28.37	5.92	35.70	57.78	56.37	74.00	17.63	Peak
4	2500.000	28.40	5.94	35.70	47.33	45.97	74.00	28.03	Peak

Remarks: 1. Emission Level= Antenna Factor + Cable Loss + Reading - Amp Factor  
 2. The emission levels that are 20dB below the official limit are not reported.

Remarks: 1. Emission Level= Antenna Factor + Cable Loss + Reading - Amp Factor  
 2. The emission levels that are 20dB below the official limit are not reported.

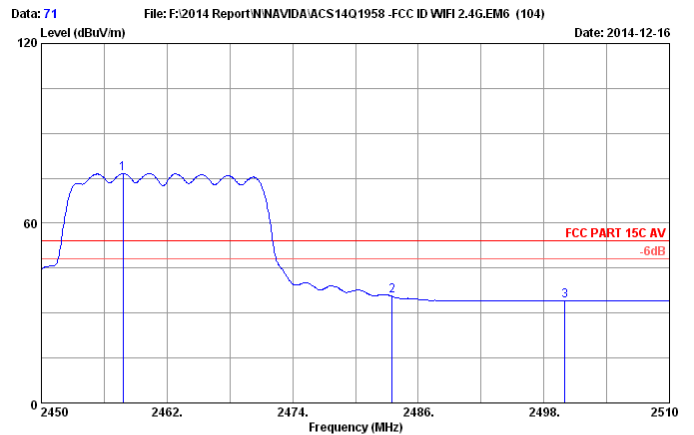
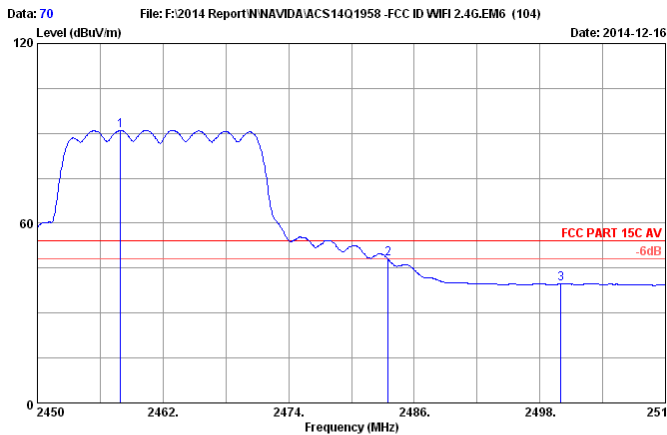

Site no. : 3m Chamber Data no. : 70  
 Dis. / Ant. : 3m 2014 3115 (4580) Ant. pol. : HORIZONTAL  
 Limit : FCC PART 15C AV  
 Env. / Ins. : 23°C/54%  
 Engineer : Kobe-Huang  
 EUT : Complex Set-Top Box  
 Power rating : DC 19V From Adppter Input AC 120V/60Hz  
 Test Mode : IEEE802.11nHT20 2462MHz Tx Mode  
 M/N : P2571

Site no. : 3m Chamber Data no. : 71  
 Dis. / Ant. : 3m 2014 3115 (4580) Ant. pol. : VERTICAL  
 Limit : FCC PART 15C AV  
 Env. / Ins. : 23°C/54%  
 Engineer : Kobe-Huang  
 EUT : Complex Set-Top Box  
 Power rating : DC 19V From Adppter Input AC 120V/60Hz  
 Test Mode : IEEE802.11nHT20 2462MHz Tx Mode  
 M/N : P2571

No.	Freq. (MHz)	Ant. Factor (dB/m)	Cable Loss (dB)	AMP factor (dB)	Reading (dBuV)	Emission Level (dBuV/m)	Limits (dBuV/m)	Margin (dB)	Remark
1	2457.920	28.31	5.88	35.70	92.48	90.97	54.00	-36.97	Average
2	2483.500	28.36	5.92	35.70	49.60	48.18	54.00	5.82	Average
3	2500.000	28.40	5.94	35.70	41.06	39.70	54.00	14.30	Average

No.	Freq. (MHz)	Ant. Factor (dB/m)	Cable Loss (dB)	AMP factor (dB)	Reading (dBuV)	Emission Level (dBuV/m)	Limits (dBuV/m)	Margin (dB)	Remark
1	2457.800	28.31	5.88	35.70	78.07	76.56	54.00	-22.56	Average
2	2483.500	28.36	5.92	35.70	37.10	35.68	54.00	18.32	Average
3	2500.000	28.40	5.94	35.70	35.56	34.20	54.00	19.80	Average

Remarks: 1. Emission Level= Antenna Factor + Cable Loss + Reading - Amp Factor  
 2. The emission levels that are 20dB below the official limit are not reported.

Remarks: 1. Emission Level= Antenna Factor + Cable Loss + Reading - Amp Factor  
 2. The emission levels that are 20dB below the official limit are not reported.

**Test Mode: IEEE 802.11n HT40**

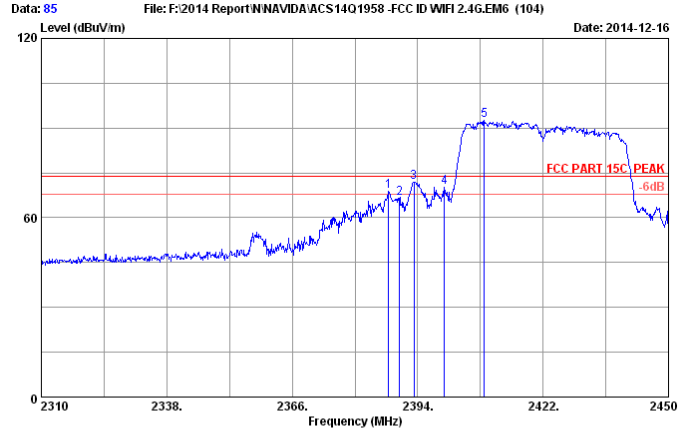
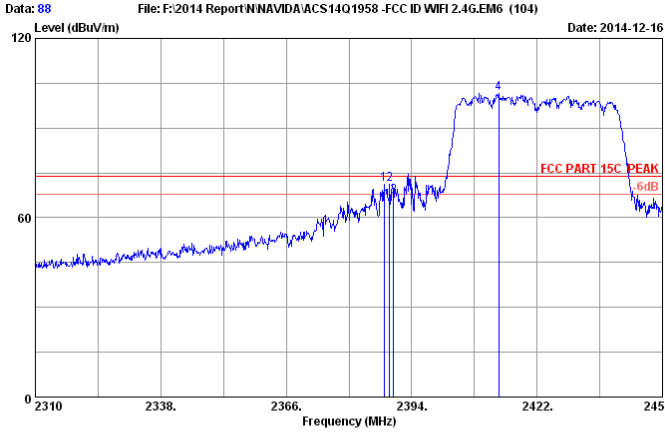

Site no. : 3m Chamber Data no. : 88  
 Dis. / Ant. : 3m 2014 3115 (4580) Ant. pol. : HORIZONTAL  
 Limit : FCC PART 15C PEAK  
 Env. / Ins. : 23°C/54%  
 Engineer : Kobe-Huang  
 EUT : Complex Set-Top Box  
 Power rating : DC 19V From Adppter Input AC 120V/60Hz  
 Test Mode : IEEE802.11nHT40 2422MHz Tx Mode  
 M/N : P2571

Site no. : 3m Chamber Data no. : 85  
 Dis. / Ant. : 3m 2014 3115 (4580) Ant. pol. : VERTICAL  
 Limit : FCC PART 15C PEAK  
 Env. / Ins. : 23°C/54%  
 Engineer : Kobe-Huang  
 EUT : Complex Set-Top Box  
 Power rating : DC 19V From Adppter Input AC 120V/60Hz  
 Test Mode : IEEE802.11nHT40 2422MHz Tx Mode  
 M/N : P2571

No.	Freq. (MHz)	Ant. Factor (dB/m)	Cable Loss (dB)	AMP factor (dB)	Reading (dBuV)	Emission Level (dBuV/m)	Limits (dBuV/m)	Margin (dB)	Remark
1	2387.840	28.15	5.78	35.70	72.99	71.22	74.00	2.78	Peak
2	2389.100	28.16	5.78	35.70	73.03	71.27	74.00	2.73	Peak
3	2390.000	28.16	5.78	35.70	69.00	67.24	74.00	6.76	Peak
4	2413.460	28.21	5.82	35.70	103.32	101.65	74.00	-27.65	Peak

No.	Freq. (MHz)	Ant. Factor (dB/m)	Cable Loss (dB)	AMP factor (dB)	Reading (dBuV)	Emission Level (dBuV/m)	Limits (dBuV/m)	Margin (dB)	Remark
1	2387.560	28.15	5.78	35.70	70.48	68.71	74.00	5.29	Peak
2	2390.000	28.16	5.78	35.70	68.28	66.52	74.00	7.48	Peak
3	2393.160	28.16	5.79	35.70	73.77	72.02	74.00	1.98	Peak
4	2400.000	28.18	5.80	35.70	71.86	70.14	74.00	3.86	Peak
5	2408.840	28.20	5.81	35.70	94.19	92.50	74.00	-18.50	Peak

Remarks: 1. Emission Level= Antenna Factor + Cable Loss + Reading -Amp Factor  
 2. The emission levels that are 20dB below the official limit are not reported.

Remarks: 1. Emission Level= Antenna Factor + Cable Loss + Reading -Amp Factor  
 2. The emission levels that are 20dB below the official limit are not reported.

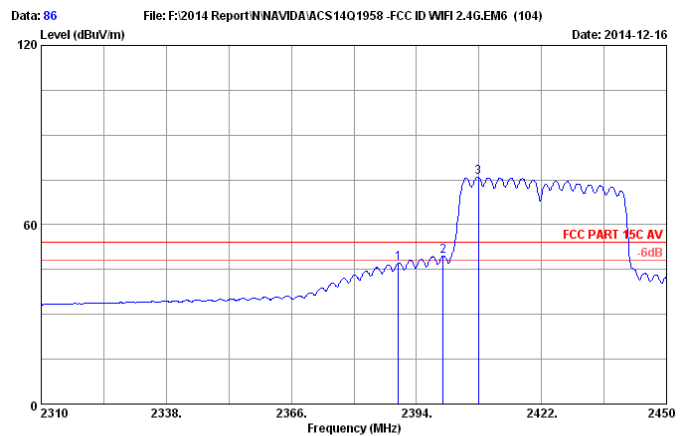
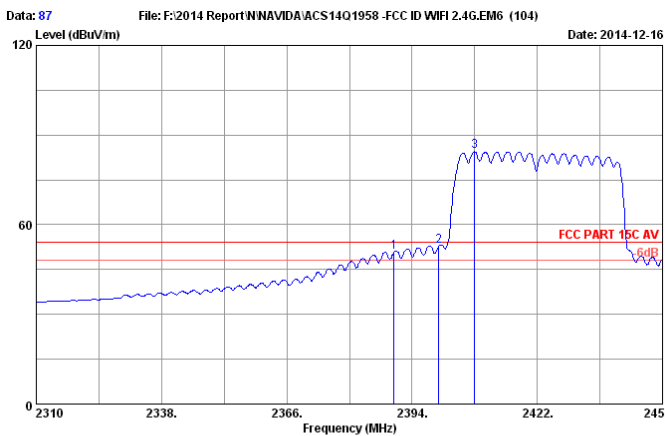

Site no. : 3m Chamber Data no. : 87  
 Dis. / Ant. : 3m 2014 3115 (4580) Ant. pol. : HORIZONTAL  
 Limit : FCC PART 15C AV  
 Env. / Ins. : 23°C/54%  
 Engineer : Kobe-Huang  
 EUT : Complex Set-Top Box  
 Power rating : DC 19V From Adppter Input AC 120V/60Hz  
 Test Mode : IEEE802.11nHT40 2422MHz Tx Mode  
 M/N : P2571

Site no. : 3m Chamber Data no. : 86  
 Dis. / Ant. : 3m 2014 3115 (4580) Ant. pol. : VERTICAL  
 Limit : FCC PART 15C AV  
 Env. / Ins. : 23°C/54%  
 Engineer : Kobe-Huang  
 EUT : Complex Set-Top Box  
 Power rating : DC 19V From Adppter Input AC 120V/60Hz  
 Test Mode : IEEE802.11nHT40 2422MHz Tx Mode  
 M/N : P2571

No.	Freq. (MHz)	Ant. Factor (dB/m)	Cable Loss (dB)	AMP factor (dB)	Reading (dBuV)	Emission Level (dBuV/m)	Limits (dBuV/m)	Margin (dB)	Remark
1	2390.000	28.16	5.78	35.70	52.43	50.67	54.00	3.33	Average
2	2400.000	28.18	5.80	35.70	54.41	52.69	54.00	1.31	Average
3	2408.000	28.20	5.81	35.70	86.10	84.41	54.00	-30.41	Average

No.	Freq. (MHz)	Ant. Factor (dB/m)	Cable Loss (dB)	AMP factor (dB)	Reading (dBuV)	Emission Level (dBuV/m)	Limits (dBuV/m)	Margin (dB)	Remark
1	2390.000	28.16	5.78	35.70	49.01	47.25	54.00	6.75	Average
2	2400.000	28.18	5.80	35.70	51.26	49.54	54.00	4.46	Average
3	2407.860	28.20	5.81	35.70	77.69	76.00	54.00	-22.00	Average

Remarks: 1. Emission Level= Antenna Factor + Cable Loss + Reading -Amp Factor  
 2. The emission levels that are 20dB below the official limit are not reported.

Remarks: 1. Emission Level= Antenna Factor + Cable Loss + Reading -Amp Factor  
 2. The emission levels that are 20dB below the official limit are not reported.

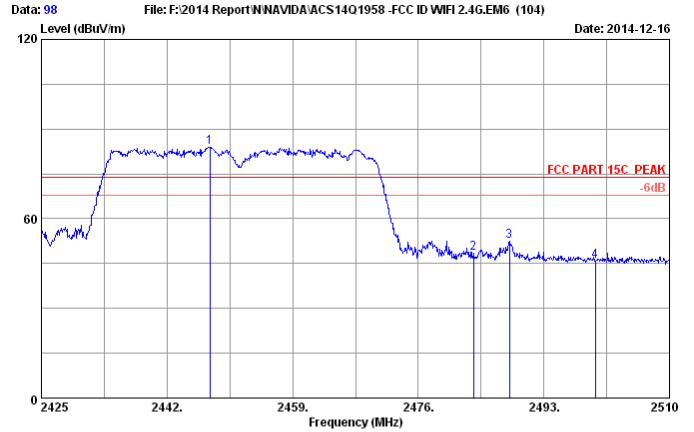
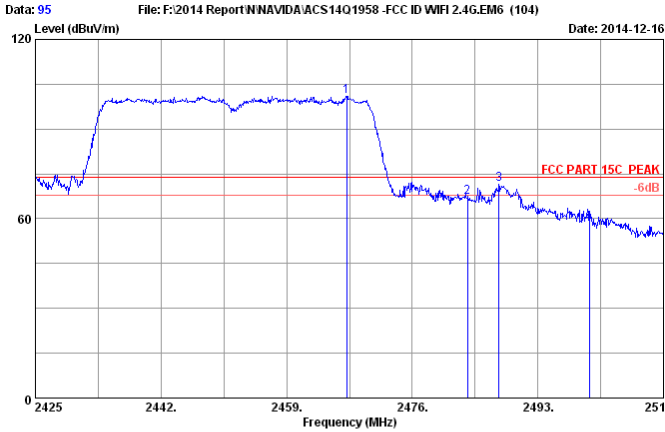

Site no. : 3m Chamber Data no. : 95  
 Dis. / Ant. : 3m 2014 3115 (4580) Ant. pol. : HORIZONTAL  
 Limit : FCC PART 15C PEAK  
 Env. / Ins. : 23°C/54%  
 Engineer : Kobe-Huang  
 EUT : Complex Set-Top Box  
 Power rating : DC 19V From Adppter Input AC 120V/60Hz  
 Test Mode : IEEE802.11nHT40 2452MHz Tx Mode  
 M/N : P2571

Site no. : 3m Chamber Data no. : 98  
 Dis. / Ant. : 3m 2014 3115 (4580) Ant. pol. : VERTICAL  
 Limit : FCC PART 15C PEAK  
 Env. / Ins. : 23°C/54%  
 Engineer : Kobe-Huang  
 EUT : Complex Set-Top Box  
 Power rating : DC 19V From Adppter Input AC 120V/60Hz  
 Test Mode : IEEE802.11nHT40 2452MHz Tx Mode  
 M/N : P2571

No.	Freq. (MHz)	Ant. Factor (dB/m)	Cable Loss (dB)	AMP factor (dB)	Reading (dBuV)	Emission Level (dBuV/m)	Limits (dBuV/m)	Margin (dB)	Remark
1	2467.160	28.33	5.89	35.70	102.43	100.95	74.00	-26.95	Peak
2	2483.500	28.36	5.92	35.70	68.64	67.22	74.00	6.78	Peak
3	2487.730	28.37	5.92	35.70	72.84	71.43	74.00	2.57	Peak
4	2500.000	28.40	5.94	35.70	59.76	58.40	74.00	15.60	Peak

No.	Freq. (MHz)	Ant. Factor (dB/m)	Cable Loss (dB)	AMP factor (dB)	Reading (dBuV)	Emission Level (dBuV/m)	Limits (dBuV/m)	Margin (dB)	Remark
1	2447.780	28.29	5.87	35.70	85.39	83.85	74.00	-9.85	Peak
2	2483.500	28.36	5.92	35.70	49.86	48.44	74.00	25.56	Peak
3	2488.325	28.37	5.93	35.70	53.78	52.38	74.00	21.62	Peak
4	2500.000	28.40	5.94	35.70	47.26	45.90	74.00	28.10	Peak

Remarks: 1. Emission Level= Antenna Factor + Cable Loss + Reading - Amp Factor  
 2. The emission levels that are 20dB below the official limit are not reported.

Remarks: 1. Emission Level= Antenna Factor + Cable Loss + Reading - Amp Factor  
 2. The emission levels that are 20dB below the official limit are not reported.

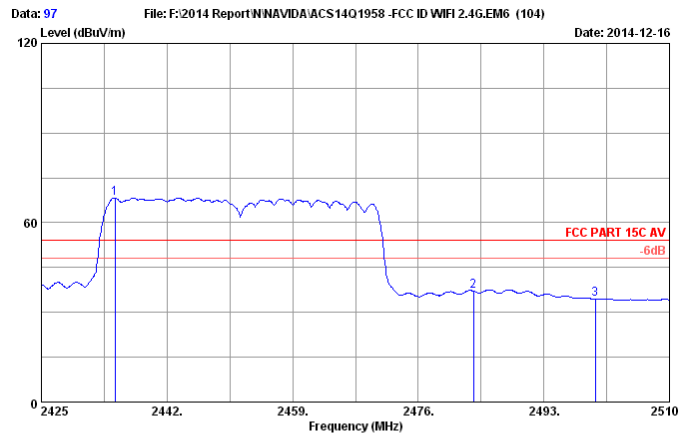
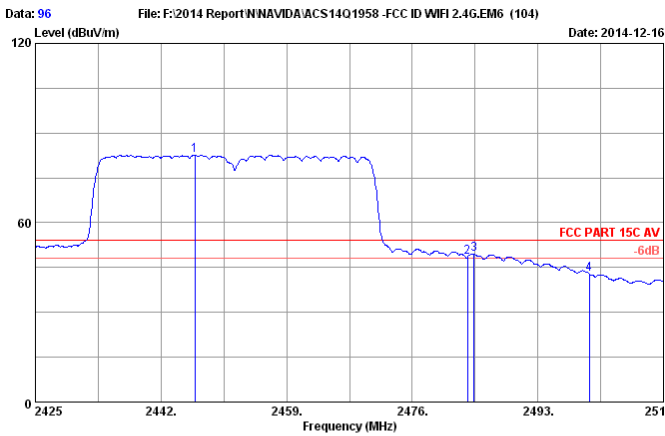

Site no. : 3m Chamber Data no. : 96  
 Dis. / Ant. : 3m 2014 3115 (4580) Ant. pol. : HORIZONTAL  
 Limit : FCC PART 15C AV  
 Env. / Ins. : 23°C/54%  
 Engineer : Kobe-Huang  
 EUT : Complex Set-Top Box  
 Power rating : DC 19V From Adppter Input AC 120V/60Hz  
 Test Mode : IEEE802.11nHT40 2452MHz Tx Mode  
 M/N : P2571

Site no. : 3m Chamber Data no. : 97  
 Dis. / Ant. : 3m 2014 3115 (4580) Ant. pol. : VERTICAL  
 Limit : FCC PART 15C AV  
 Env. / Ins. : 23°C/54%  
 Engineer : Kobe-Huang  
 EUT : Complex Set-Top Box  
 Power rating : DC 19V From Adppter Input AC 120V/60Hz  
 Test Mode : IEEE802.11nHT40 2452MHz Tx Mode  
 M/N : P2571

No.	Freq. (MHz)	Ant. Factor (dB/m)	Cable Loss (dB)	AMP factor (dB)	Reading (dBuV)	Emission Level (dBuV/m)	Limits (dBuV/m)	Margin (dB)	Remark
1	2446.590	28.28	5.86	35.70	84.11	82.55	54.00	-28.55	Average
2	2483.500	28.36	5.92	35.70	49.91	48.49	54.00	5.51	Average
3	2484.330	28.37	5.92	35.70	50.92	49.51	54.00	4.49	Average
4	2500.000	28.40	5.94	35.70	44.29	42.93	54.00	11.07	Average

No.	Freq. (MHz)	Ant. Factor (dB/m)	Cable Loss (dB)	AMP factor (dB)	Reading (dBuV)	Emission Level (dBuV/m)	Limits (dBuV/m)	Margin (dB)	Remark
1	2434.945	28.26	5.85	35.70	69.94	68.35	54.00	-14.35	Average
2	2483.500	28.36	5.92	35.70	38.59	37.17	54.00	16.83	Average
3	2500.000	28.40	5.94	35.70	35.81	34.45	54.00	19.55	Average

Remarks: 1. Emission Level= Antenna Factor + Cable Loss + Reading - Amp Factor  
 2. The emission levels that are 20dB below the official limit are not reported.

Remarks: 1. Emission Level= Antenna Factor + Cable Loss + Reading - Amp Factor  
 2. The emission levels that are 20dB below the official limit are not reported.

## 7. 6dB Bandwidth Test

### 7.1. Test Equipment

Item	Equipment	Manufacturer	Model No.	Serial No.	Last Cal.	Cal. Interval
1.	Spectrum	Agilent	E4446A	US44300459	Apr. 28,14	1 Year
2.	Spectrum	Agilent	N9030A	MY51380221	Oct.29, 14	1Year
3.	Attenuator (20dB)	Agilent	8491B	MY39262165	Apr. 28,14	1 Year
4.	RF Cable	Hubersuhner	SUCOFLEX102	28620/2	Apr. 28,14	1 Year

### 7.2. Limit

For direct sequence systems, the minimum 6dB bandwidth shall be at least 500kHz

### 7.3. Test Procedure

The transmitter output was connected to a spectrum analyzer, The bandwidth of the fundamental frequency was measured by spectrum analyzer with 100kHz RBW and 300kHz VBW. The 6dB bandwidth is defined as the total spectrum the power of which is higher than peak power minus 6dB.

### 7.4. Test Results

EUT: Complex Set-Top Box		
M/N: P2571		
Test date: 2014-12-20	Pressure: 101.6±1.0 kpa	Humidity: 50.9±3.0%
Tested by: kobe_huang	Test site: RF site	Temperature: 23.1±0.6 °C

Test Mode	CH	6dB bandwidth (MHz)		Limit (KHz)
		ANT 1	ANT 2	
11b	CH1	9.087	9.060	>500
	CH6	9.087	9.052	>500
	CH11	9.087	9.054	>500
11g	CH1	16.41	16.38	>500
	CH6	16.55	16.38	>500
	CH11	16.39	16.37	>500
11n HT20	CH1	16.38	17.62	>500
	CH6	16.39	17.61	>500
	CH11	16.37	17.60	>500
11n HT40	CH3	36.46	36.52	>500
	CH6	36.48	36.48	>500
	CH9	36.43	36.48	>500

Conclusion : PASS

**ANT 1:**

Test Mode: IEEE 802.11b TX

Test CH1: 2412MHz

Test Mode: IEEE 802.11g TX

Test CH1: 2412MHz

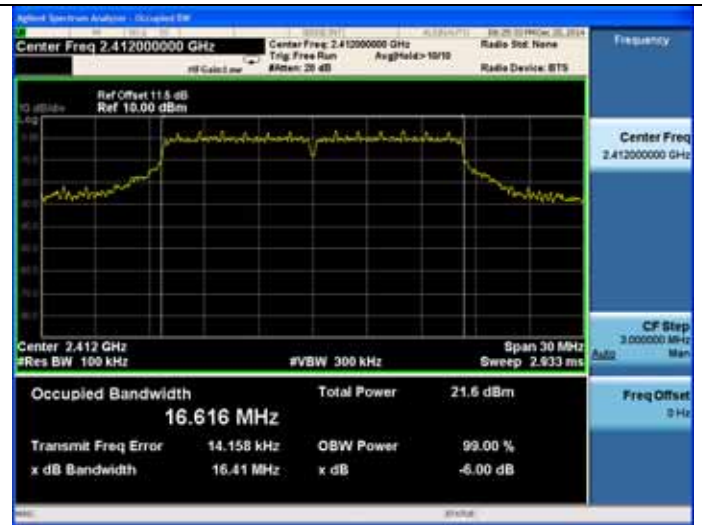

Test CH6: 2437MHz

Test CH6: 2437MHz



Test CH11: 2462MHz

Test CH11: 2462MHz



Test Mode: IEEE 802.11n HT20 TX  
Test CH1: 2412MHz

Test Mode: IEEE 802.11n HT40 TX  
Test CH1: 2422MHz

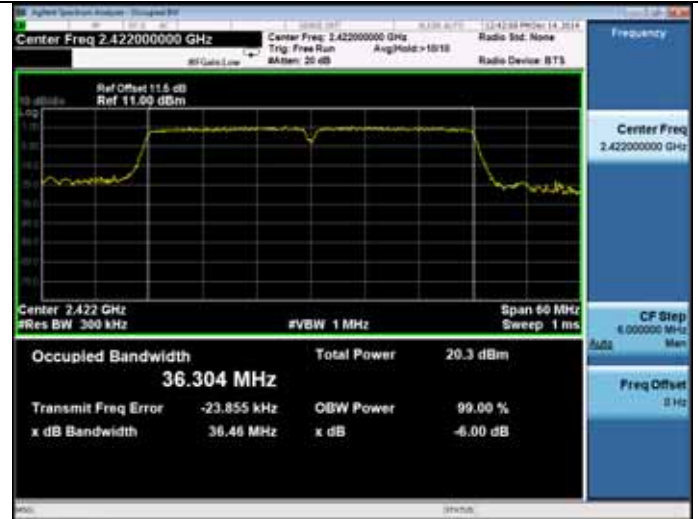
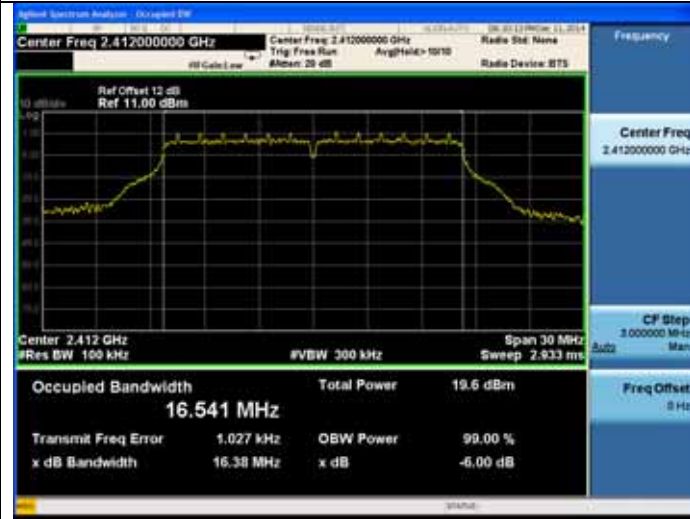

Test CH6: 2437MHz

Test CH4: 2437MHz

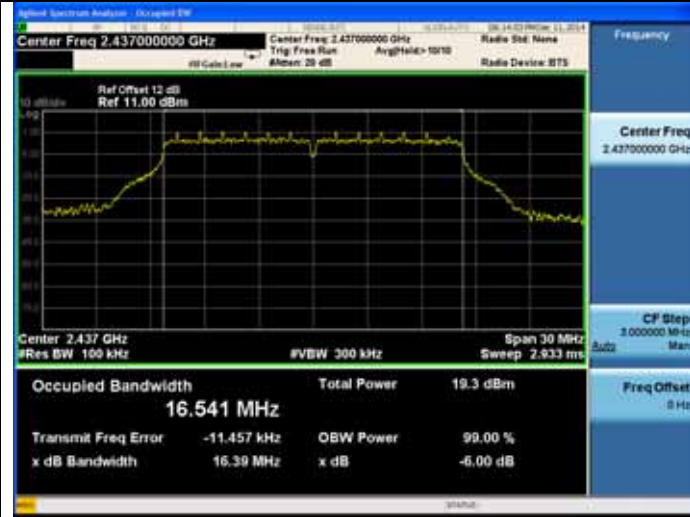

Test CH11: 2462MHz

Test CH7: 2452MHz

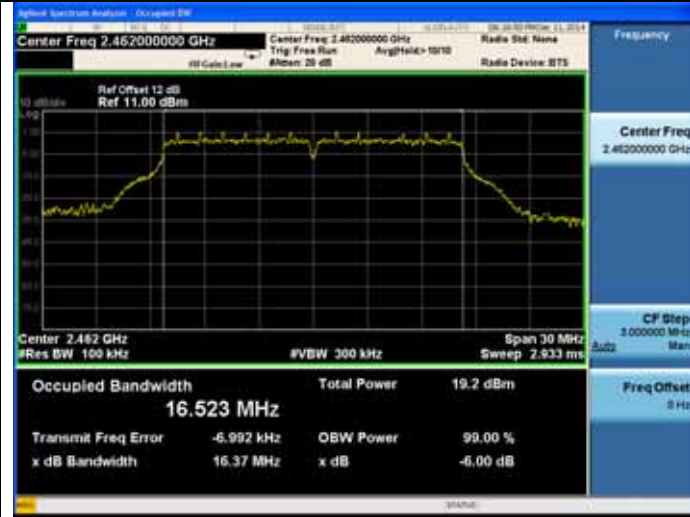



**ANT 2:**

Test Mode: IEEE 802.11b TX

Test CH1: 2412MHz

Test Mode: IEEE 802.11g TX

Test CH1: 2412MHz

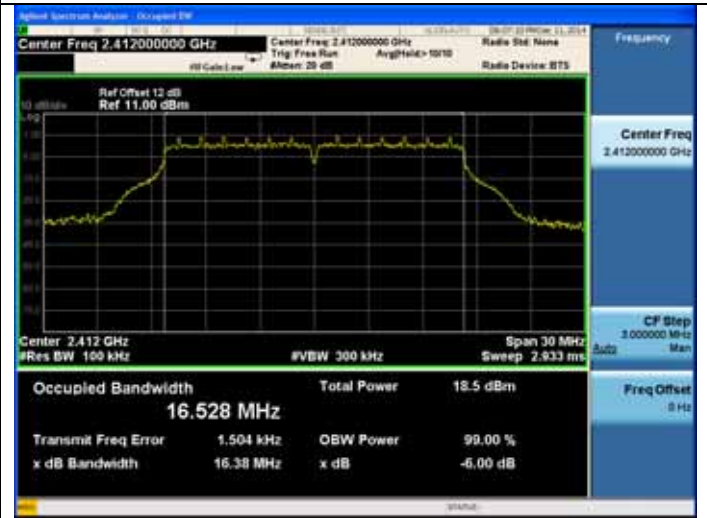

**Test CH6: 2437MHz**

**Test CH6: 2437MHz**

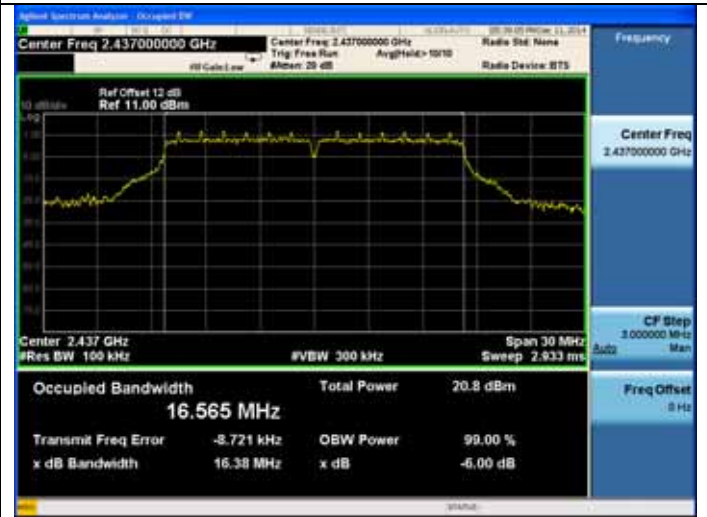

**Test CH11: 2462MHz**

**Test CH11: 2462MHz**

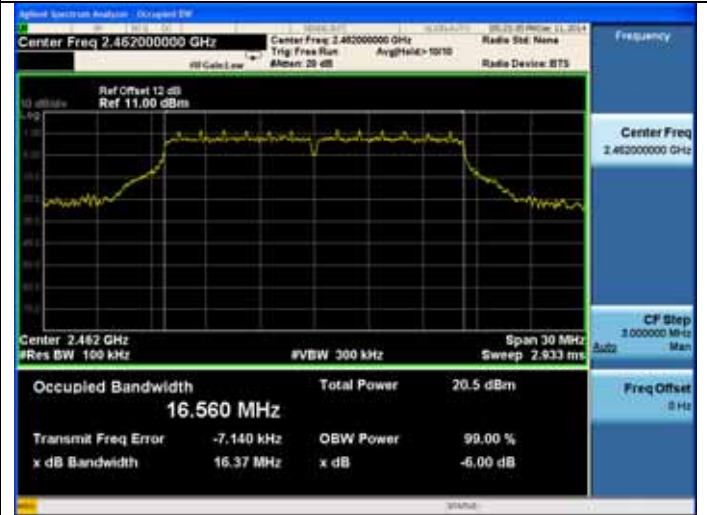

Test Mode: IEEE 802.11n HT20 TX  
Test CH1: 2412MHz

Test Mode: IEEE 802.11n HT40 TX  
Test CH1: 2422MHz

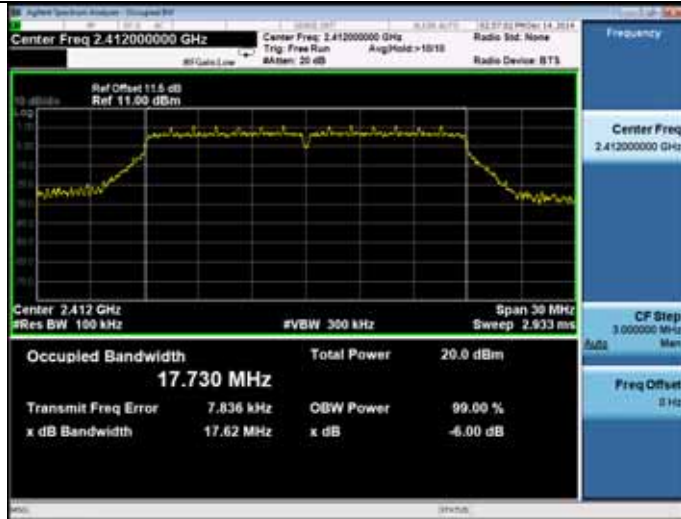

Test CH6: 2437MHz

Test CH4: 2437MHz

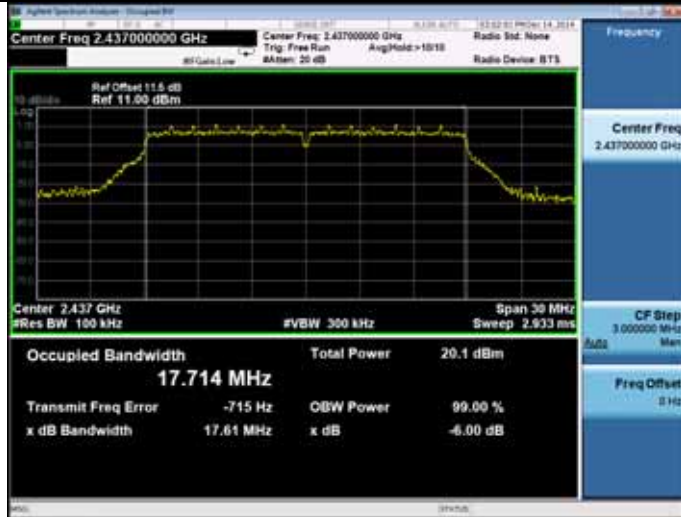

Test CH11: 2462MHz

Test CH7: 2452MHz



## 8. OUTPUT POWER TEST

### 8.1. Test Equipment

Item	Equipment	Manufacturer	Model No.	Serial No.	Last Cal.	Cal. Interval
1.	Spectrum	Agilent	N9030A	MY51380221	Oct.29, 14	1Year
2.	Power meter	Anritsu	ML2487A	6K00002472	Apr. 28,14	1Year
3.	Power sensor	Anritsu	MA2491A	0033005	Apr. 28,14	1Year
4.	Attenuator (20dB)	Agilent	8491B	MY39262165	Apr. 28,14	1Year
5.	RF Cable	Hubersuhner	SUCOFLEX102	28610/2	Apr. 28,14	1Year

### 8.2. Limit (FCC Part 15C 15.247 b(3))

For systems using digital modulation in the 2400—2483.5MHz, The Peak output Power shall not exceed 1W(30dBm), As an alternative to a peak power measurement, compliance with the one Watt limit can be based on a measurement of the maximum conducted output power. Maximum Conducted Output Power is defined as the total transmit power delivered to all antennas and antenna elements averaged across all symbols in the signaling alphabet when the transmitter is operating at its maximum power control level.

### 8.3. Test Procedure

- 1, Connected the EUT's antenna port to measure device by 26dB attenuator.
- 2, For IEEE 802.11b/g and IEEE802.11n HT20 modes, use a power meter which bandwidth is 20MHz, above the bandwidth of signals, to measure out output power in each mode.
- 3, For IEEE802.11n HT40 mode, since the signal bandwidth is nearly 40MHz, which is above 20MHz bandwidth of power sensor of ML2491A. use the test method descried in KDB558074 clause 9.2.2.
  - 1) Set the RBW=1MHz and VBW =3MHz
  - 2) Set the span at least 1.5 times the OBW
  - 3) Detector = RMS
  - 4) Sweep time = auto couple
  - 5) allow trace to fully stabilize
  - 6) use the spectrum analyser's integrated band power measurement function with band limits set equal to the EBW band edges.

Note: The cable loss and attenuator loss were offset into measure device as an amplitude offset.

8.4. Test Results

EUT: Complex Set-Top Box					
M/N: P2571					
Test date: 2014-01-12		Pressure: 101.9±1.0 kpa		Humidity: 51.6±3.0%	
Tested by: Kobe_huang		Test site: RF site		Temperature:23.1±0.6 °C	
Test Mode	CH	Max. Average Conducted Output Power (dBm)			Limit (dBm)
		ANT1	ANT2	Total	
11b	CH1	18.59	18.63	N/A	30
	CH6	18.53	18.59	N/A	30
	CH11	17.33	17.95	N/A	30
11g	CH1	17.02	17.55	N/A	30
	CH6	18.57	18.69	N/A	30
	CH11	16.94	17.59	N/A	30
11n HT20	CH1	12.95	13.23	16.10	29.25/30
	CH6	18.53	18.55	21.55	29.25/30
	CH11	14.69	14.78	17.75	29.25/30
11n HT40	CH3	10.08	10.18	13.14	29.25/30
	CH6	15.24	15.66	18.47	29.25/30
	CH9	10.47	10.53	13.51	29.25/30
Conclusion: PASS					

Note: For 11n Mode

- Correlated signal: Directional Gain =  $10\log [(10^{G1/20} + 10^{G2/20})^2 / N_{ANT}] = 6.75\text{dBi}$   
The limit =  $30\text{dBm} - (6.75 - 6)\text{dBi} = 29.25\text{dBm}$
- Uncorrelated signal: Directional Gain =  $10\log [(10^{G1/10} + 10^{G2/10}) / N_{ANT}] = 3.75\text{dBi}$   
The limit do not need rollback.

**ANT 1:**

Test Mode: IEEE 802.11n HT40 TX

Test CH1: 2422MHz



**ANT 2:**

Test Mode: IEEE 802.11n HT40 TX

Test CH1: 2422MHz



**Test CH4: 2437MHz**



**Test CH4: 2437MHz**



**Test CH7: 2452MHz**



**Test CH7: 2452MHz**



## 9. POWER SPECTRAL DENSITY TEST

### 9.1. Test Equipment

Item	Equipment	Manufacturer	Model No.	Serial No.	Last Cal.	Cal. Interval
1.	Spectrum	Agilent	N9030A	MY51380221	Oct.29, 14	1 Year
2.	Attenuator (20dB)	Agilent	8491B	MY39262165	Apr. 28,14	1 Year
3	RF Cable	Hubersuhner	SUCOFLEX102	28610/2	Apr. 28,14	1 Year

### 9.2. Limit

For digitally modulated systems, the power spectral density conducted from the intentional radiator to the antenna shall not be greater than 8dBm in any 3kHz band during any time interval of continuous transmission.

### 9.3. Test Procedure

1. Connected the EUT's antenna port to spectrum analyzer device by 20dB attenuator.
2. Set the test frequency as center frequency, Set RBW=3KHz, VBW=10KHz, Span large enough capture the entire frequency, Read out maximum peak level frequency
3. Set the frequency read from produce 2 as center frequency, then set the span= 300KHz, Sweep time=Span/RBW, Then Max hold, read out each mode and each ANT's Power density.

Note: The cable loss and attenuator loss were offset into measure device as an amplitude

### 9.4. Test Results

EUT: Complex Set-Top Box		
M/N: P2571		
Test date: 2014-10-30	Pressure: 101.1±1.0 kpa	Humidity: 52.1±3.0%
Tested by: Kobe_Huang	Test site: RF Site	Temperature: 22.5±0.6°C

Test Mode	CH	Power density ( dBm/3KHz )			Limit (dBm/3KHz)
		ANT1	ANT2	Total	
11b	CH1	1.468	0.736	N/A	8
	CH6	3.77	2.472	N/A	8
	CH11	0.868	-1.181	N/A	8
11g	CH1	-3.724	-5.564	N/A	8
	CH6	-2.02	-2.273	N/A	8
	CH11	-5.123	-5.732	N/A	8

Test Mode	CH	Power density ( dBm/3KHz )			Limit (dBm/3KHz)
		ANT1	ANT2	Total	
11n HT20	CH1	-7.768	-8.935	-5.30	7.25/8
	CH6	-1.903	-2.209	0.96	7.25/8
	CH11	-6.777	-7.218	-3.98	7.25/8
11n HT40	CH3	-13.931	-14.704	-11.29	7.25/8
	CH6	-8.079	-8.645	-5.34	7.25/8
	CH9	-13.259	-13.01	-10.12	7.25/8

Conclusion : PASS

Note: For 11n Mode

1. Correlated signal: Directional Gain =  $10\log [(10^{G1/20} + 10^{G2/20})^2 / N_{ANT}] = 6.75\text{dBi}$   
The limit =  $8\text{dBm} - (6.75 - 6)\text{dBi} = 7.25\text{dBm}$
2. Uncorrelated signal: Directional Gain =  $10\log [(10^{G1/10} + 10^{G2/10}) / N_{ANT}] = 3.75\text{dBi}$   
The limit do not need rollback.

**ANT 1:**

Test Mode: IEEE 802.11b TX  
Test CH1: 2412MHz

Test Mode: IEEE 802.11g TX  
Test CH1: 2412MHz

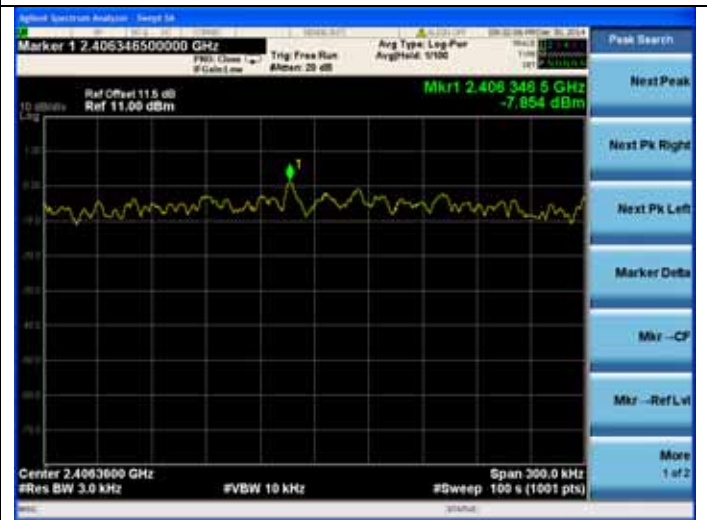
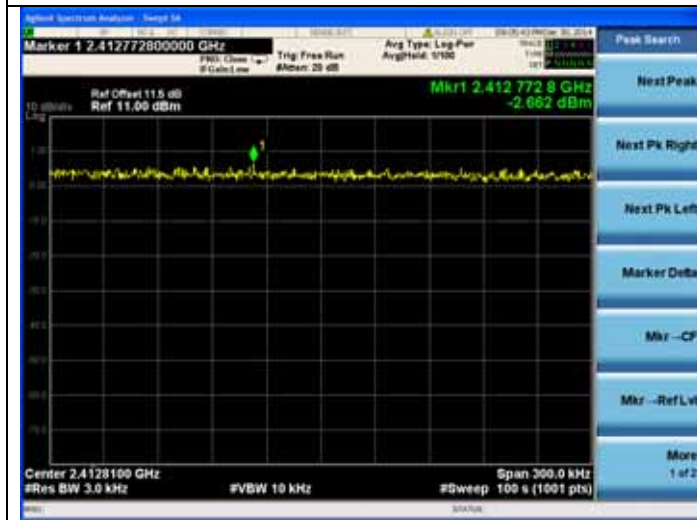

Test CH6: 2437MHz

Test CH6: 2437MHz

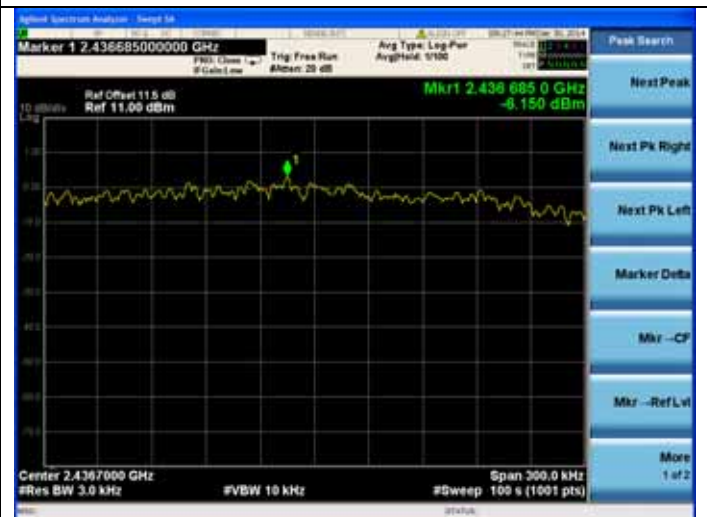

Test CH11: 2462MHz

Test CH11: 2462MHz





Test Mode: IEEE 802.11n HT20 TX  
Test CH1: 2412MHz



Test Mode: IEEE 802.11n HT40 TX  
Test CH1: 2422MHz



Test CH6: 2437MHz



Test CH4: 2437MHz



Test CH11: 2462MHz



Test CH7: 2452MHz



**ANT 2:**

Test Mode: IEEE 802.11b TX  
Test CH1: 2412MHz

Test Mode: IEEE 802.11g TX  
Test CH1: 2412MHz

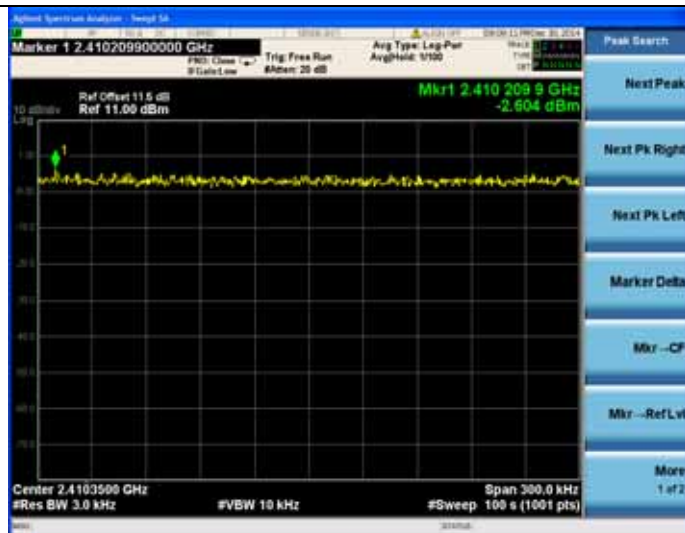

**Test CH6: 2437MHz**

**Test CH6: 2437MHz**

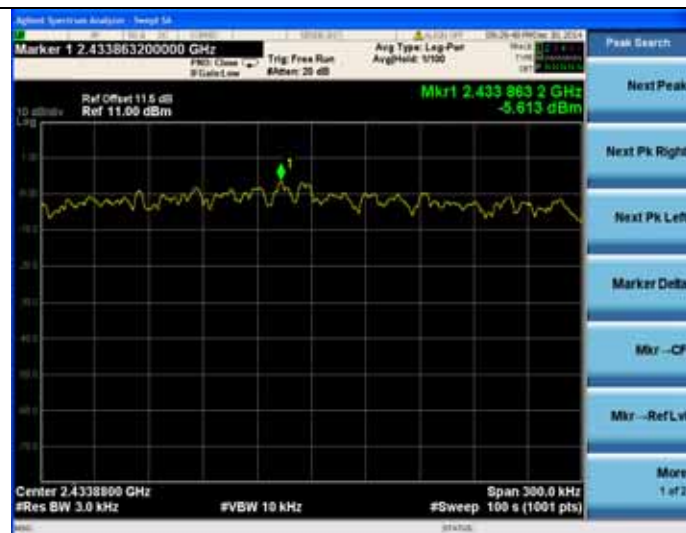
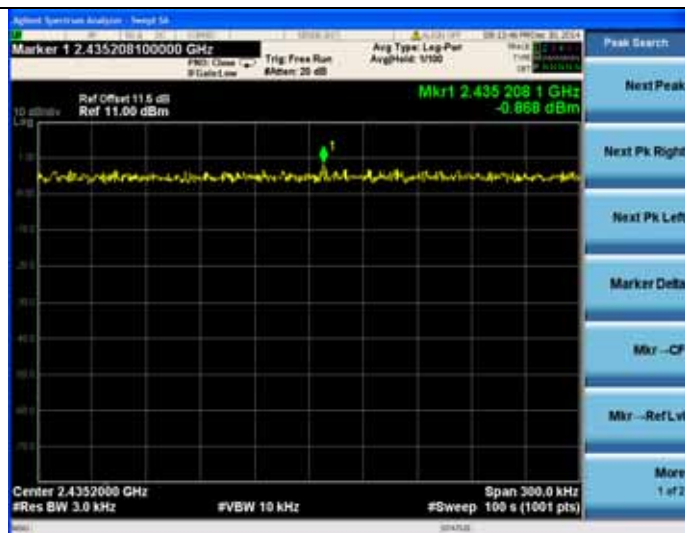

**Test CH11: 2462MHz**

**Test CH11: 2462MHz**

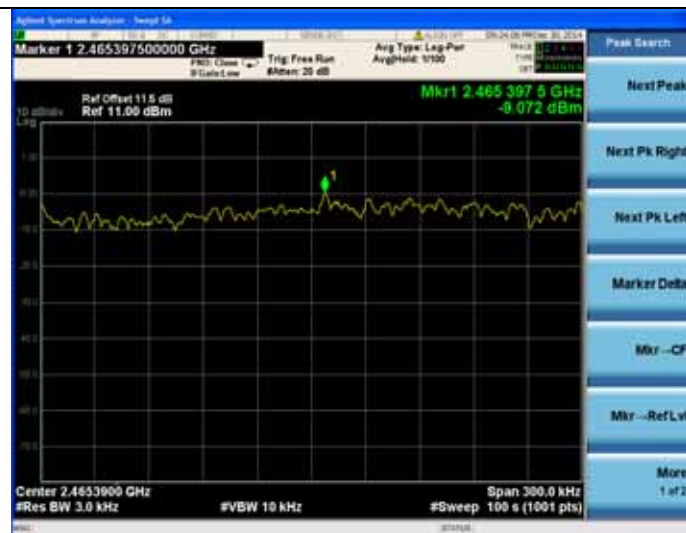

Test Mode: IEEE 802.11n HT20 TX  
Test CH1: 2412MHz

Test Mode: IEEE 802.11n HT40 TX  
Test CH1: 2422MHz



Test CH6: 2437MHz

Test CH4: 2437MHz



Test CH11: 2462MHz

Test CH7: 2452MHz



## **11. ANTENNA REQUIREMENT**

### **11.1. STANDARD APPLICABLE**

For intentional device, according to FCC 47 CFR Section 15.203, an intentional radiator shall be designed to ensure that no antenna other than that furnished by the responsible party shall be used with the device. And according to FCC 47 CFR Section 15.247 (b), if transmitting antennas of directional gain greater than 6dBi are used, the power shall be reduced by the amount in dB that the directional gain of the antenna exceeds 6dBi.

### **11.2. ANTENNA CONNECTED CONSTRUCTION**

The antennas used for this product are Dipole antenna that no antenna other than that furnished by the responsible party shall be used with the device, the maximum peak gain of the transmit antenna is 4.13dBi.

## 12.DEVIATION TO TEST SPECIFICATIONS

[ NONE]