



Neutron Engineering Inc.

FCC&IC Radio Test Report

FCC ID: VOB-P1988W

IC: 7361A-P1988W

This report concerns (check one): Original Grant Class II Change

Issued Date : May. 22, 2014
Project No. : 1405C177
Equipment : Tablet
Model Name : P1988w
Applicant : NVIDIA CORPORATION
Address : 2701 SAN TOMAS EXPRESSWAY, SANTA CLARA, CALIFORNIA 95050, UNITED STATES OF AMERICA

Tested by: Neutron Engineering Inc. EMC Laboratory
Date of Receipt: Feb. 10, 2014
Date of Test: Feb. 10, 2014 ~ May. 21, 2014

Testing Engineer : David Mao
(David Mao)

Technical Manager : Leo Hung
(Leo Hung)

Authorized Signatory : Steven Lu
(Steven Lu)

Neutron Engineering Inc.

No.3, Jinshagang 1st Road, ShiXia,
Dalang Town, Dong Guan, China.

TEL: 0769-8318-3000

FAX: 0769-8319-6000



Declaration

Neutron represents to the client that testing is done in accordance with standard procedures as applicable and that test instruments used has been calibrated with the standards traceable to National Measurement Laboratory (**NML**) of **R.O.C.**, or National Institute of Standards and Technology (**NIST**) of **U.S.A.**

Neutron's reports apply only to the specific samples tested under conditions. It is manufacture's responsibility to ensure that additional production units of this model are manufactured with the identical electrical and mechanical components. **Neutron** shall have no liability for any declarations, inferences or generalizations drawn by the client or others from **Neutron** issued reports.

Neutron's reports must not be used by the client to claim product endorsement by the authorities or any agency of the Government.

This report is the confidential property of the client. As a mutual protection to the clients, the public and **Neutron-self**, extracts from the test report shall not be reproduced except in full with **Neutron's** authorized written approval.

Neutron's laboratory quality assurance procedures are in compliance with the **ISO Guide 17025** requirements, and accredited by the conformity assessment authorities listed in this test report.

Limitation

For the use of the authority's logo is limited unless the Test Standard(s)/Scope(s)/Item(s) mentioned in this test report is (are) included in the conformity assessment authorities acceptance respective.



Table of Contents	Page
REPORT ISSUED HISTORY	5
1 . CERTIFICATION	6
2 . SUMMARY OF TEST RESULTS	7
2.1 TEST FACILITY	8
2.2 MEASUREMENT UNCERTAINTY	8
3 . GENERAL INFORMATION	9
3.1 GENERAL DESCRIPTION OF EUT	9
3.2 DESCRIPTION OF TEST MODES	11
3.3 TABLE OF PARAMETERS OF TEXT SOFTWARE SETTING	12
3.4 BLOCK DIAGRAM SHOWING THE CONFIGURATION OF SYSTEM TESTED	13
3.5 DESCRIPTION OF SUPPORT UNITS	13
4 . EMC EMISSION TEST	14
4.1 CONDUCTED EMISSION MEASUREMENT	14
4.1.1 POWER LINE CONDUCTED EMISSION LIMITS	14
4.1.2 TEST PROCEDURE	14
4.1.3 DEVIATION FROM TEST STANDARD	14
4.1.4 TEST SETUP	15
4.1.5 EUT OPERATING CONDITIONS	15
4.1.6 EUT TEST CONDITIONS	15
4.1.7 TEST RESULTS	15
4.2 RADIATED EMISSION MEASUREMENT	18
4.2.1 RADIATED EMISSION LIMITS	18
4.2.2 TEST PROCEDURE	19
4.2.3 DEVIATION FROM TEST STANDARD	19
4.2.4 TEST SETUP	20
4.2.5 EUT OPERATING CONDITIONS	21
4.2.6 EUT TEST CONDITIONS	21
4.2.7 TEST RESULTS (BELOW 30MHZ)	22
4.2.8 TEST RESULTS: 30MHZ TO 1000MHZ	23
4.2.8 TEST RESULTS (ABOVE 1000 MHZ)	30
5 . BANDWIDTH TEST	38
5.1 APPLIED PROCEDURES / LIMIT	38
5.1.1 TEST PROCEDURE	38
5.1.2 DEVIATION FROM STANDARD	38
5.1.3 TEST SETUP	38
5.1.4 EUT OPERATION CONDITIONS	38
5.1.5 EUT TEST CONDITIONS	38



	Page
5.1.6 TEST RESULTS	39
6 . MAXIMUM OUTPUT POWER TEST	41
6.1 APPLIED PROCEDURES / LIMIT	41
6.1.1 TEST PROCEDURE	41
6.1.2 DEVIATION FROM STANDARD	41
6.1.3 TEST SETUP	41
6.1.4 EUT OPERATION CONDITIONS	41
6.1.5 EUT TEST CONDITIONS	41
6.1.6 TEST RESULTS	42
7 . ANTENNA CONDUCTED SPURIOUS EMISSION	43
7.1 APPLIED PROCEDURES / LIMIT	43
7.1.1 TEST PROCEDURE	43
7.1.2 DEVIATION FROM STANDARD	43
7.1.3 TEST SETUP	43
7.1.4 EUT OPERATION CONDITIONS	43
7.1.5 EUT OPERATION CONDITIONS	43
7.1.6 TEST RESULTS	43
8 . POWER SPECTRAL DENSITY TEST	48
8.1 APPLIED PROCEDURES / LIMIT	48
8.1.1 TEST PROCEDURE	48
8.1.2 DEVIATION FROM STANDARD	48
8.1.3 TEST SETUP	48
8.1.4 EUT OPERATION CONDITIONS	48
8.1.5 EUT TEST CONDITIONS	48
8.1.6 TEST RESULTS	49
9 . MEASUREMENT INSTRUMENTS LIST	51
10 . EUT TEST PHOTO	53



REPORT ISSUED HISTORY

Issued No.	Description	Issued Date
NEI-FICP-2-1405C177	Original Issue.	May. 22, 2014



1. CERTIFICATION

Equipment : Tablet
Brand Name : NVIDIA
Model Name : P1988w
Applicant : NVIDIA CORPORATION
Manufacturer : NVIDIA CORPORATION
Address : 2701 SAN TOMAS EXPRESSWAY, SANTA CLARA, CALIFORNIA 95050,
UNITED STATES OF AMERICA
Factory : HONGFUJIN PRECISION ELECTRONICS (TIANJIN) CO., LTD
Address : A01, NO.36, North Street, West Zone, Economic & Technological Development
Area, Tianjin
Date of Test : Feb. 10, 2014 ~ May. 21, 2014
Test Item : ENGINEERING SAMPLE
Standard(s) : FCC Part15, Subpart C(15.247) / ANSI C63.4-2009
Canada RSS-210:2010
RSS-GEN Issue 3, Dec 2010

The above equipment has been tested and found compliance with the requirement of the relative standards by Neutron Engineering Inc. EMC Laboratory.

The test data, data evaluation, and equipment configuration contained in our test report (Ref No. NEI-FICP-2-1405C177) were obtained utilizing the test procedures, test instruments, test sites that has been accredited by the Authority of TAF according to the ISO-17025 quality assessment standard and technical standard(s).



2. SUMMARY OF TEST RESULTS

Test procedures according to the technical standard(s):

Applied Standard(s): FCC Part15 (15.247) , Subpart C Canada RSS-210:2010; RSS-GEN Issue 3, Dec 2010				
Standard(s)	Section	Test Item	Judgment	Remark
15.207	RSS-GEN 7.2.2	Conducted Emission	PASS	
15.247(d)	RSS-210 Annex 8 (A8.5)	Antenna conducted Spurious Emission	PASS	
15.247(a)(2)	RSS-210 Annex 8 (A8.2(a))	6dB Bandwidth	PASS	
15.247(b)(3)	RSS-210 Annex 8 (A8.4(4))	Peak Output Power	PASS	
15.247(e)	RSS-210 Annex 8 (A8.2(b))	Power Spectral Density	PASS	
15.203	-	Antenna Requirement	PASS	
15.209/15.205	RSS-210 Annex 8 (A8.5)	Transmitter Radiated Emissions	PASS	

NOTE:

- (1) "N/A" denotes test is not applicable in this test report.
- (2) The test follows FCC KDB Publication No. 558074 D01 DTS Meas Guidance v03r01 (Measurement Guidelines of DTS)



2.1 TEST FACILITY

The test facilities used to collect the test data in this report is **DG-C02/DG-CB03** at the location of No.3, Jinshagang 1st Road, ShiXia, Dalang Town, Dong Guan, China.523792
 Neutron's test firm number for FCC: 319330

2.2 MEASUREMENT UNCERTAINTY

Where relevant, the following measurement uncertainty levels have been estimated for tests performed on the EUT as specified in CISPR 16-4-2:

The reported uncertainty of measurement $y \pm U$, where expanded uncertainty U is based on a standard uncertainty multiplied by a coverage factor of $k=2$, providing a level of confidence of approximately 95 %.

A. Conducted Measurement :

Test Site	Method	Measurement Frequency Range	U , (dB)	NOTE
DG-C02	CISPR	150 KHz ~ 30MHz	1.94	

B. Radiated Measurement :

Test Site	Method	Measurement Frequency Range	Ant. H / V	U,(dB)	NOTE
DG-CB03	CISPR	9KHz~30MHz	V	3.79	
		9KHz~30MHz	H	3.57	
		30MHz ~ 200MHz	V	3.82	
		30MHz ~ 200MHz	H	3.60	
		200MHz ~ 1,000MHz	V	3.86	
		200MHz ~ 1,000MHz	H	3.94	
		1GHz~18GHz	V	3.12	
		1GHz~18GHz	H	3.68	
		18GHz~40GHz	V	4.15	
		18GHz~40GHz	H	4.14	



3. GENERAL INFORMATION

3.1 GENERAL DESCRIPTION OF EUT

Equipment	Tablet	
Brand Name	NVIDIA	
Model Name	P1988w	
Model Difference	N/A	
Product Description	Operation Frequency	2402~2480 MHz
	Modulation Technology	GFSK(1Mbps)
	Bit Rate of Transmitter	
	Output Power (Max.)	2.45 dBm (1Mbps)
Power Source	#1 DC voltage supplied from AC adapter. 1) Brand/ Model: NVIDIA / P2551 2) Brand/ Model: Chicony / W12-010N3A #2 Supplied from lithium-ion battery. 1) Brand/ Model: YOKU/ 32102102 #3 Supplied from USB charging.	
Power Rating	#1 AC adapter 1) I/P: AC 100-240V~, 50-60Hz, 0.3A O/P: DC 5.2V, 2.1A 2) I/P: AC 100-240V~, 50/60Hz, 0.3A O/P: DC 5.35V, 2A #2 Lithium-ion battery 1) DC 3.7V 4100mAh #3 USB charging 1) DC 5V 2A	

Note:

1. For a more detailed features description, please refer to the manufacturer's specifications or the User's Manual.



2.

Channel List			
Channel	Frequency (MHz)	Channel	Frequency (MHz)
00	2402	20	2442
01	2404	21	2444
02	2406	22	2446
03	2408	23	2448
04	2410	24	2450
05	2412	25	2452
06	2414	26	2454
07	2416	27	2456
08	2418	28	2458
09	2420	29	2460
10	2422	30	2462
11	2424	31	2464
12	2426	32	2466
13	2428	33	2468
14	2430	34	2470
15	2432	35	2472
16	2434	36	2474
17	2436	37	2476
18	2438	38	2478
19	2440	39	2480

3. Table for Filed Antenna

Ant.	Brand	Model Name	Antenna Type	Connector	Gain (dBi)
1	SPEED	G-KW-0002	Monopole	N/A	6.3



3.2 DESCRIPTION OF TEST MODES

To investigate the maximum EMI emission characteristics generates from EUT, the test system was pre-scanning tested base on the consideration of following EUT operation mode or test configuration mode which possible have effect on EMI emission level. Each of these EUT operation mode(s) or test configuration mode(s) mentioned above was evaluated respectively.

Pretest Mode	Description
Mode 1	TX Mode NOTE (1)
Mode 2	TX Mode

The EUT system operated these modes were found to be the worst case during the pre-scanning test as following:

For Conducted Test	
Final Test Mode	Description
Mode 2	TX Mode

For Radiated Test	
Final Test Mode	Description
Mode 1	TX Mode NOTE (1)

Note:

(1) The measurements are performed at the high, middle, low available channels.



3.3 TABLE OF PARAMETERS OF TEXT SOFTWARE SETTING

During testing channel & power controlling software provided by the customer was used to control the operating channel as well as the output power level. The RF output power selection is for the setting of RF output power expected by the customer and is going to be fixed on the firmware of the final end product power parameters of WLAN

Test software version	Bluetest		
Frequency	2402MHz	2440 MHz	2480MHz
GFSK-1Mbps	25	25	25



3.4 BLOCK DIAGRAM SHOWING THE CONFIGURATION OF SYSTEM TESTED

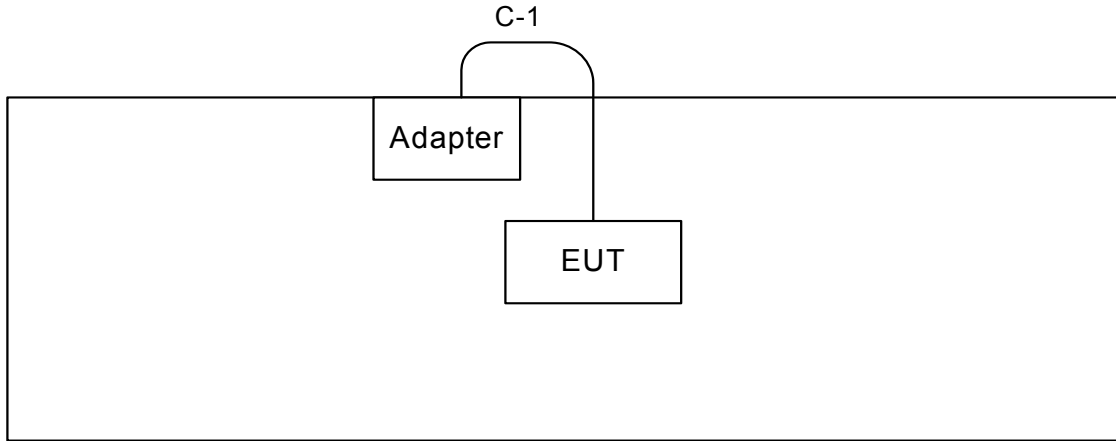

3.5 DESCRIPTION OF SUPPORT UNITS

The EUT has been tested as an independent unit together with other necessary accessories or support units. The following support units or accessories were used to form a representative test configuration during the tests.

Item	Equipment	Mfr/Brand	Model/Type No.	FCC ID/IC	Series No.	Note
-	-	-	-	-	-	

Item	Shielded Type	Ferrite Core	Length	Note
C-1	YES	NO	0.8m	USB Cable



4. EMC EMISSION TEST

4.1 CONDUCTED EMISSION MEASUREMENT

4.1.1 POWER LINE CONDUCTED EMISSION Limits (Frequency Range 150KHz-30MHz)

Frequency (MHz)	Class A (dBuV)		Class B (dBuV)		Standard
	Quasi-peak	Average	Quasi-peak	Average	
0.15 -0.5	79.00	66.00	66 - 56 *	56 - 46 *	CISPR
0.50 -5.0	73.00	60.00	56.00	46.00	CISPR
5.0 -30.0	73.00	60.00	60.00	50.00	CISPR

0.15 -0.5	79.00	66.00	66 - 56 *	56 - 46 *	FCC
0.50 -5.0	73.00	60.00	56.00	46.00	FCC
5.0 -30.0	73.00	60.00	60.00	50.00	FCC

Note:

- (1) The tighter limit applies at the band edges.
- (2) The limit of " * " marked band means the limitation decreases linearly with the logarithm of the frequency in the range.

The following table is the setting of the receiver

Receiver Parameters	Setting
Attenuation	10 dB
Start Frequency	0.15 MHz
Stop Frequency	30 MHz
IF Bandwidth	9 kHz

4.1.2 TEST PROCEDURE

- a. The EUT was placed 0.8 meters from the horizontal ground plane with EUT being connected to the power mains through a line impedance stabilization network (LISN). All other support equipments powered from additional LISN(s). The LISN provide 50 Ohm/ 50uH of coupling impedance for the measuring instrument.
- b. Interconnecting cables that hang closer than 40 cm to the ground plane shall be folded back and forth in the center forming a bundle 30 to 40 cm long.
- c. I/O cables that are not connected to a peripheral shall be bundled in the center. The end of the cable may be terminated, if required, using the correct terminating impedance. The overall length shall not exceed 1 m.
- d. LISN at least 80 cm from nearest part of EUT chassis.
- e. For the actual test configuration, please refer to the related Item –EUT Test Photos.

4.1.3 DEVIATION FROM TEST STANDARD

No deviation

4.1.4 TEST SETUP

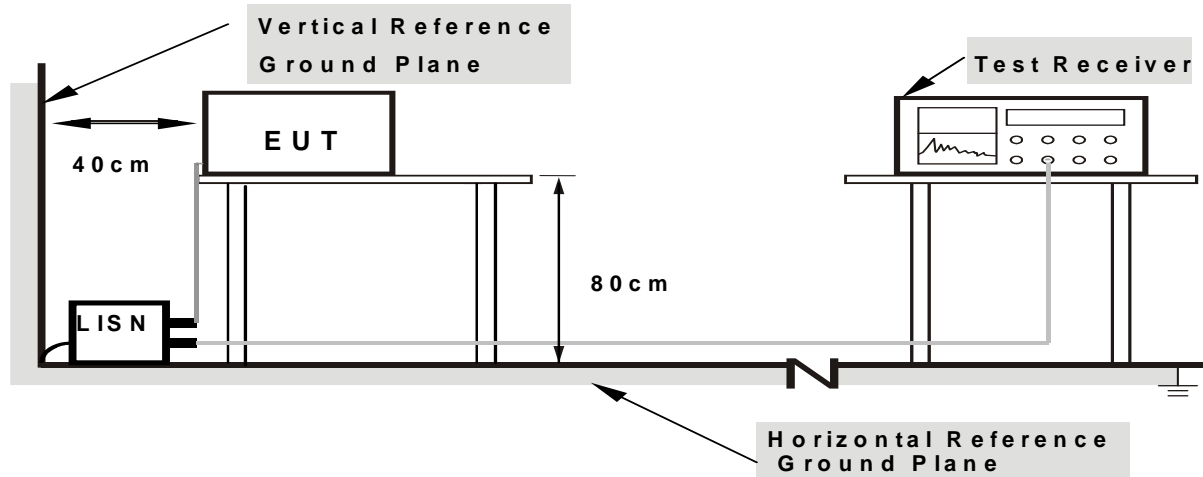

- Note:**
1. Support units were connected to second LISN.
 2. Both of LISNs (AMN) are 80 cm from EUT and at least 80 from other units and other metal planes

4.1.5 EUT OPERATING CONDITIONS

The EUT was configured for testing in a typical fashion (as a customer would normally use it). The EUT has been programmed to continuously transmit during test. This operating condition was tested and used to collect the included data.

4.1.6 EUT TEST CONDITIONS

Temperature: 25°C
Relative Humidity: 55%
Test Voltage: 120V/60Hz

4.1.7 TEST RESULTS

Remark:

- (1) All readings are QP Mode value unless otherwise stated AVG in column of "Note". If the QP Mode Measured value compliance with the QP Limits and lower than AVG Limits, the EUT shall be deemed to meet both QP & AVG Limits and then only QP Mode was measured, but AVG Mode didn't perform. In this case, a "*" marked in AVG Mode column of Interference Voltage Measured.
- (2) Measuring frequency range from 150KHz to 30MHz.
- (3) "N/A" denotes test is not applicable in this test report.



Test Mode: TX Mode (Adapter: P2551)

Line

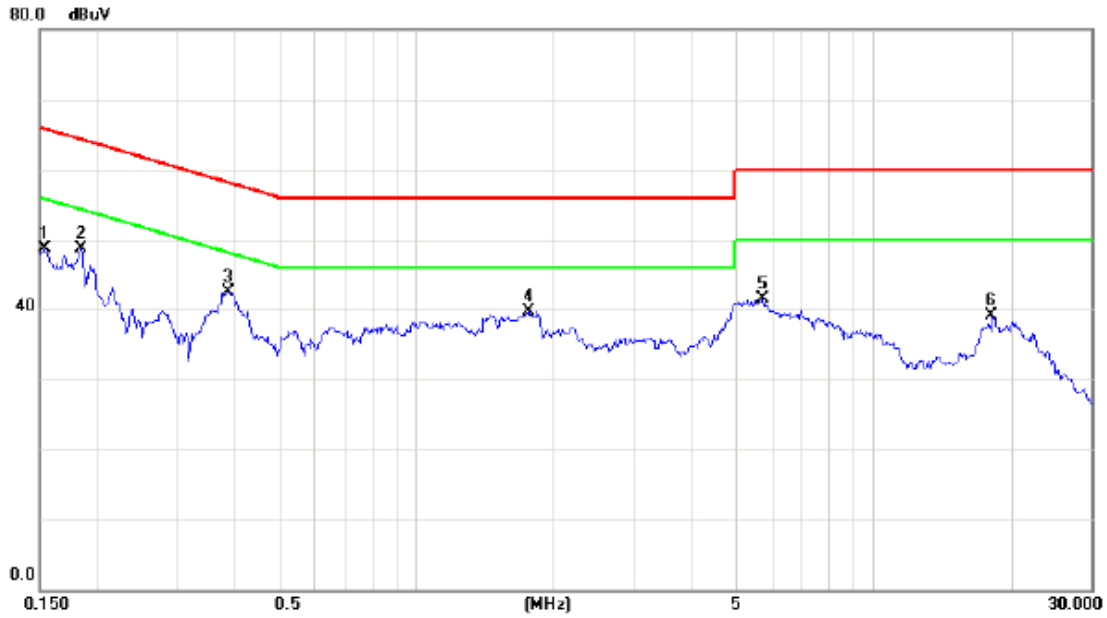

No.	Mk.	Freq. MHz	Reading Level dBuV	Correct Factor dB	Measure- ment dBuV	Limit dBuV	Over dB	Detector	Comment
1		0.1540	38.99	9.63	48.62	65.78	-17.16	peak	
2		0.1850	39.05	9.65	48.70	64.26	-15.56	peak	
3	*	0.3881	32.91	9.68	42.59	58.10	-15.51	peak	
4		1.7593	29.90	9.82	39.72	56.00	-16.28	peak	
5		5.7134	31.50	9.94	41.44	60.00	-18.56	peak	
6		18.2030	28.80	10.28	39.08	60.00	-20.92	peak	



Test Mode: TX Mode (Adapter: P2551)

Neutral

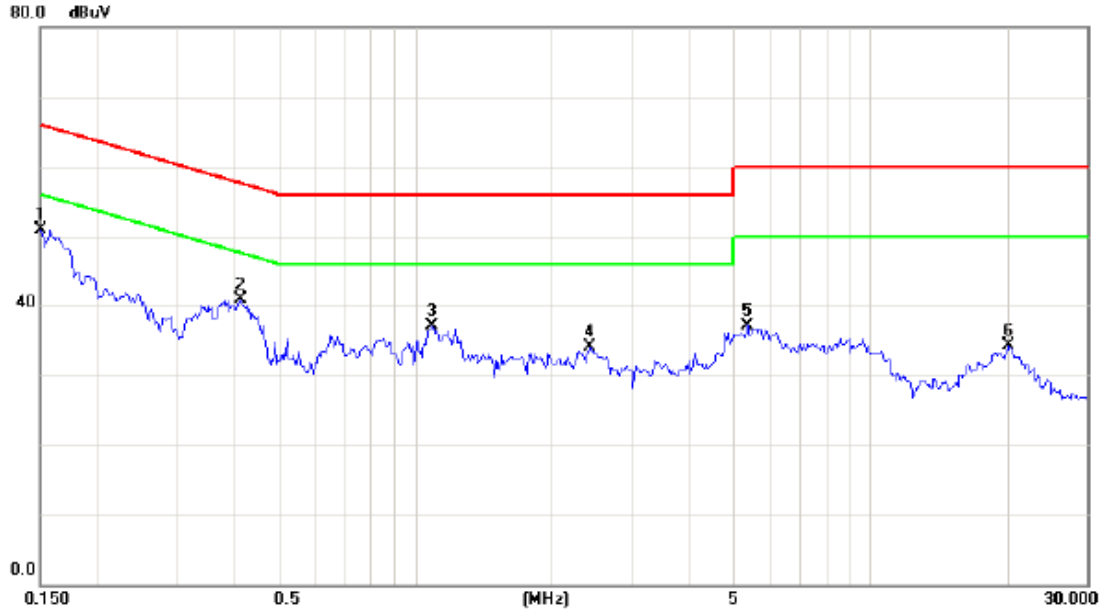

No.	Mk.	Freq. MHz	Reading Level dBuV	Correct Factor dB	Measure- ment dBuV	Limit dBuV	Over dB	Detector	Comment
1	*	0.1507	41.23	9.70	50.93	65.96	-15.03	peak	
2		0.4126	31.09	9.73	40.82	57.60	-16.78	peak	
3		1.0910	27.29	9.78	37.07	56.00	-18.93	peak	
4		2.4312	24.29	9.88	34.17	56.00	-21.83	peak	
5		5.3867	27.23	9.97	37.20	60.00	-22.80	peak	
6		20.1992	23.82	10.39	34.21	60.00	-25.79	peak	



4.2 RADIATED EMISSION MEASUREMENT

4.2.1 RADIATED EMISSION LIMITS (Frequency Range 9KHz-1000MHz)

20dBc in any 100 kHz bandwidth outside the operating frequency band. In case the emission fall within the restricted band specified on 15.205(a), then the 15.209(a) limit in the table below has to be followed.

Frequencies (MHz)	Field Strength (microvolts/meter)	Measurement Distance (meters)
0.009~0.490	2400/F(KHz)	300
0.490~1.705	24000/F(KHz)	30
1.705~30.0	30	30
30~88	100	3
88~216	150	3
216~960	200	3
960~1000	500	3

Section 15.33 Frequency range of radiated measurements.

Unless otherwise noted in the specific rule section under which the equipment operates for an intentional radiator the spectrum shall be investigated from the lowest radio frequency signal generated in the device, without going below 9 kHz, up to at least the frequency shown in this paragraph:

- (1) If the intentional radiator operates below 10 GHz: to the tenth harmonic of the highest fundamental frequency or to 40 GHz, whichever is lower.
- (2) If the intentional radiator operates at or above 10 GHz and below 30 GHz: to the fifth harmonic of the highest fundamental frequency or to 100 GHz, whichever is lower.
- (3) If the intentional radiator operates at or above 30 GHz: to the fifth harmonic of the highest fundamental frequency or to 200 GHz, whichever is lower, unless specified otherwise elsewhere in the rules
- (4) If the intentional radiator contains a digital device, regardless of whether this digital device controls the functions of the intentional radiator or the digital device is used for additional control or function purposes other than to enable the operation of the intentional radiator, the frequency range shall be investigated up to the range specified in paragraphs (a)(1)-(a)(3) of this section or the range applicable to the digital device, as shown in paragraph (b)(1) of this Section, whichever is the higher frequency range of investigation.



Spectrum Parameter	Setting
Attenuation	Auto
Start Frequency	1000 MHz
Stop Frequency	10th carrier harmonic
RBW / VBW (Emission in restricted band)	1MHz / 1MHz for Peak, 1 MHz / 10Hz for Average

Receiver Parameter	Setting
Attenuation	Auto
Start ~ Stop Frequency	9kHz~90kHz for PK/AVG detector
Start ~ Stop Frequency	90kHz~110kHz for QP detector
Start ~ Stop Frequency	110kHz~490kHz for PK/AVG detector
Start ~ Stop Frequency	490kHz~30MHz for QP detector
Start ~ Stop Frequency	30MHz~1000MHz for QP detector

4.2.2 TEST PROCEDURE

- a. The EUT was placed on the top of a rotating table 0.8 meters above the ground at a 3 meter semi-anechoic chamber. The table was rotated 360 degrees to determine the position of the highest radiation.(below 1GHz)
- b. The EUT was placed on the top of a rotating table 0.8 meters above the ground at a 3 meter fully-anechoic chamber. The table was rotated 360 degrees to determine the position of the highest radiation.(above 1GHz)
- c. The height of the equipment or of the substitution antenna shall be 0.8 m; the height of the test antenna shall vary between 1 m to 4 m. Both horizontal and vertical polarizations of the antenna are set to make the measurement.
- d. The initial step in collecting conducted emission data is a spectrum analyzer peak detector mode pre-scanning the measurement frequency range. Significant peaks are then marked and then Quasi Peak detector mode re-measured.
- e. If the Peak Mode measured value compliance with and lower than Quasi Peak Mode Limit, the EUT shall be deemed to meet QP Limits and then no additional QP Mode measurement performed.
- f. For the actual test configuration, please refer to the related Item –EUT Test Photos.

4.2.3 DEVIATION FROM TEST STANDARD

No deviation

4.2.4 TEST SETUP

(A) Radiated Emission Test Set-Up Frequency Below 1 GHz

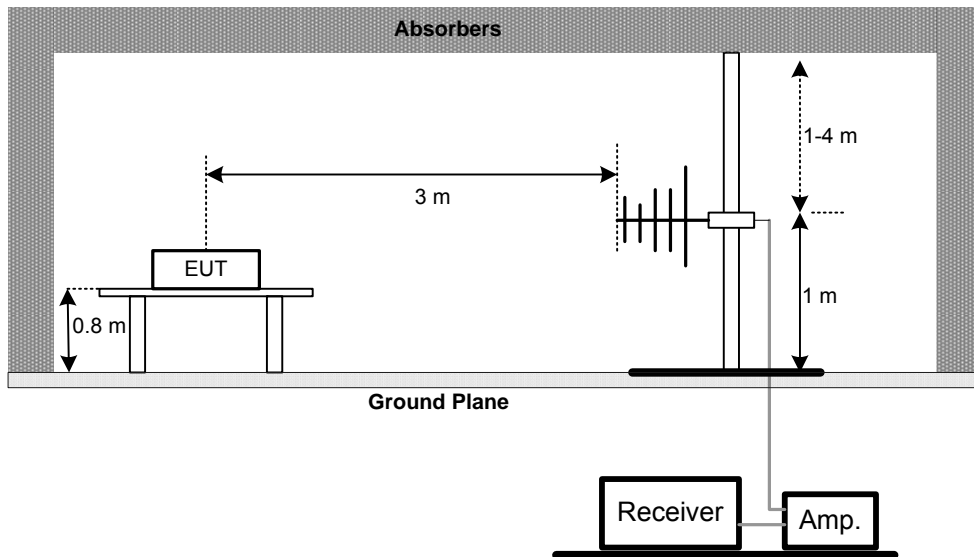

(B) Radiated Emission Test Set-Up Frequency Above 1 GHz

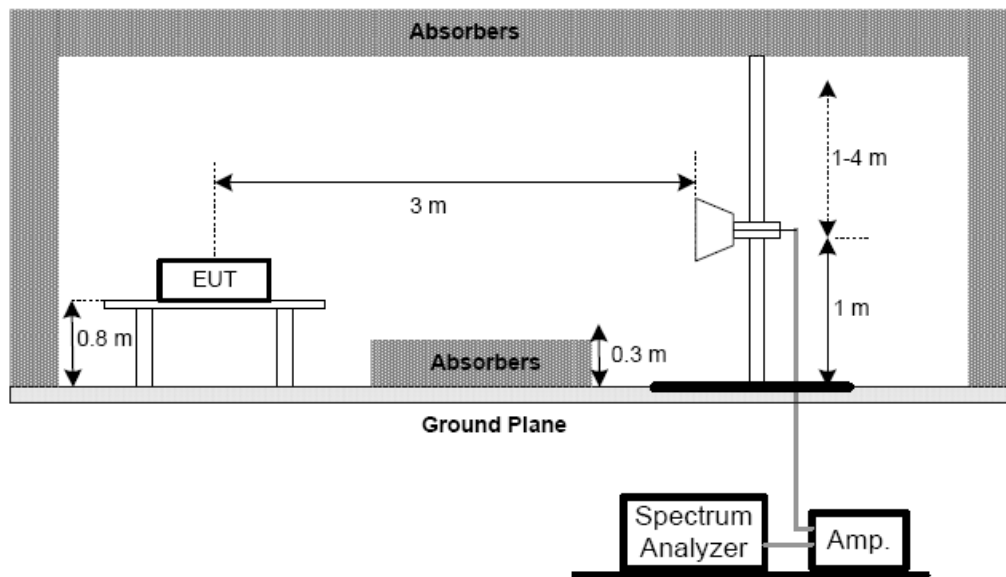

Note: The antenna can be moved between 1 to 4 meters above the ground.

(C) For radiated emissions below 30MHz

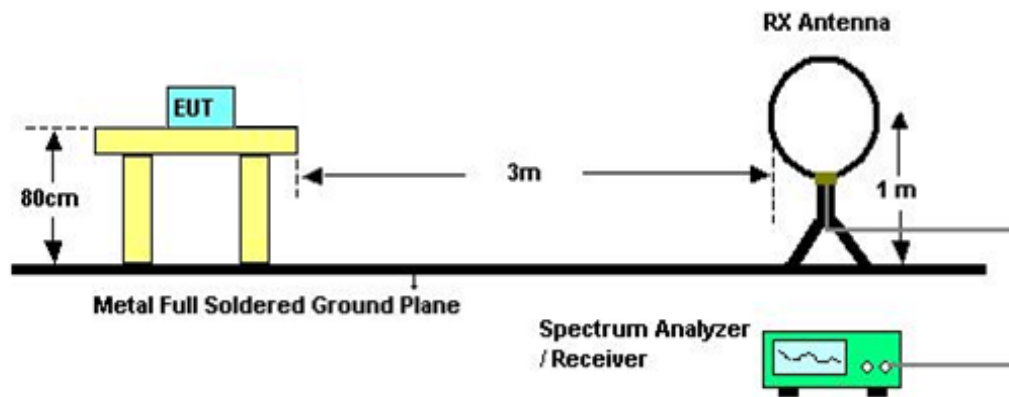

4.2.5 EUT OPERATING CONDITIONS

The EUT tested system was configured as the statements of 4.1.6 Unless otherwise a special operating condition is specified in the follows during the testing.

4.2.6 EUT TEST CONDITIONS

Temperature: 25°C

Relative Humidity: 55%

Test Voltage: 120V/60Hz



4.2.7 TEST RESULTS (BELOW 30MHZ)

Test Mode:	TX 2402MHz (Adapter: P2551)
------------	-----------------------------

Freq. (MHz)	Ant. 0°/90°	Reading(RA) (dBuV)	Corr.Factor(CF) (dB)	Measured(FS) (dBuV/m)	Limits(QP) (dBuV/m)	Margin (dB)	Note
0.0094	0°	68.35	24.30	92.65	128.12	-35.47	AV
0.0094	0°	72.35	24.30	96.65	148.12	-51.47	PK
0.0137	0°	70.35	24.30	94.65	124.87	-30.22	AV
0.0137	0°	79.35	24.30	103.65	144.87	-41.22	PK
0.0245	0°	56.36	24.02	80.38	119.82	-39.45	AV
0.0245	0°	60.12	24.02	84.14	139.82	-55.69	PK
0.0328	0°	61.36	23.49	84.85	117.29	-32.44	AV
0.0328	0°	65.38	23.49	88.87	137.29	-48.42	PK
0.5680	0°	18.72	20.02	38.74	72.52	-33.78	QP
1.7536	0°	18.95	19.52	38.47	69.54	-31.07	QP

Freq. (MHz)	Ant. 0°/90°	Reading(RA) (dBuV)	Corr.Factor(CF) (dB)	Measured(FS) (dBuV/m)	Limits(QP) (dBuV/m)	Margin (dB)	Note
0.0095	0°	76.35	24.30	100.65	128.03	-27.38	AV
0.0095	90°	82.36	24.30	106.66	148.03	-41.37	PK
0.0248	90°	56.38	24.00	80.38	119.72	-39.34	AV
0.0248	90°	59.35	24.00	83.35	139.72	-56.37	PK
0.0332	90°	57.35	23.46	80.81	117.18	-36.37	AV
0.0332	90°	58.35	23.46	81.81	137.18	-55.37	PK
0.0478	90°	59.35	22.54	81.89	114.02	-32.13	AV
0.0478	90°	63.35	22.54	85.89	134.02	-48.13	PK
0.4952	90°	17.45	19.81	37.26	73.71	-36.45	QP
1.7647	90°	18.63	19.52	38.15	69.54	-31.39	QP

Remark:

- (1) The amplitude of spurious emissions which are attenuated by more than 20 dB below the permissible value has no need to be reported.
- (2) Distance extrapolation factor = 40 log (specific distance / test distance) (dB).
- (3) Limit line = specific limits (dBuV) + distance extrapolation factor.



4.2.8 TEST RESULTS: 30MHZ TO 1000MHZ

Remark:

- (1) Reading in which marked as QP or Peak means measurements by using are Quasi-Peak Mode or Peak Mode with Detector BW=120KHz ; SPA setting in RBW=120KHz, VBW =120KHz, Swp. Time = 0.3 sec./MHz.
- (2) All readings are Peak unless otherwise stated QP in column of 『Note』 . Peak denotes that the Peak reading compliance with the QP Limits and then QP Mode measurement didn't perform.
- (3) Measuring frequency range from 30MHz to 1000MHz.
- (4) If the peak scan value lower limit more than 20dB, then this signal data does not show in table.



Test Mode: TX 2402MHz -CH00 -1Mbps (Adapter: P2551)

Vertical

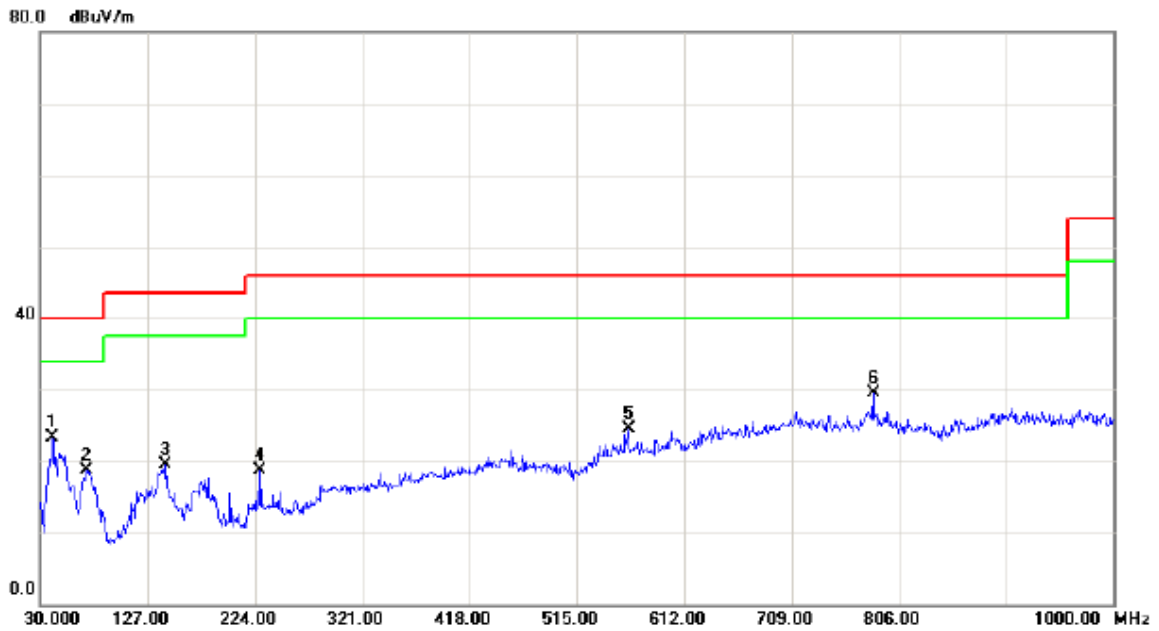

No.	Mk.	Freq. MHz	Reading Level dBuV	Correct Factor dB	Measure- ment dBuV/m	Limit dBuV/m	Over dB	Detector	Comment
1		40.6700	37.86	-14.58	23.28	40.00	-16.72	peak	
2		71.7100	35.22	-16.46	18.76	40.00	-21.24	peak	
3		143.4900	33.24	-13.76	19.48	43.50	-24.02	peak	
4		228.8500	33.32	-14.54	18.78	46.00	-27.22	peak	
5		561.5600	32.23	-7.76	24.47	46.00	-21.53	peak	
6	*	782.7200	33.26	-3.72	29.54	46.00	-16.46	peak	



Test Mode: TX 2402MHz -CH00 -1Mbps (Adapter: P2551)

Horizontal

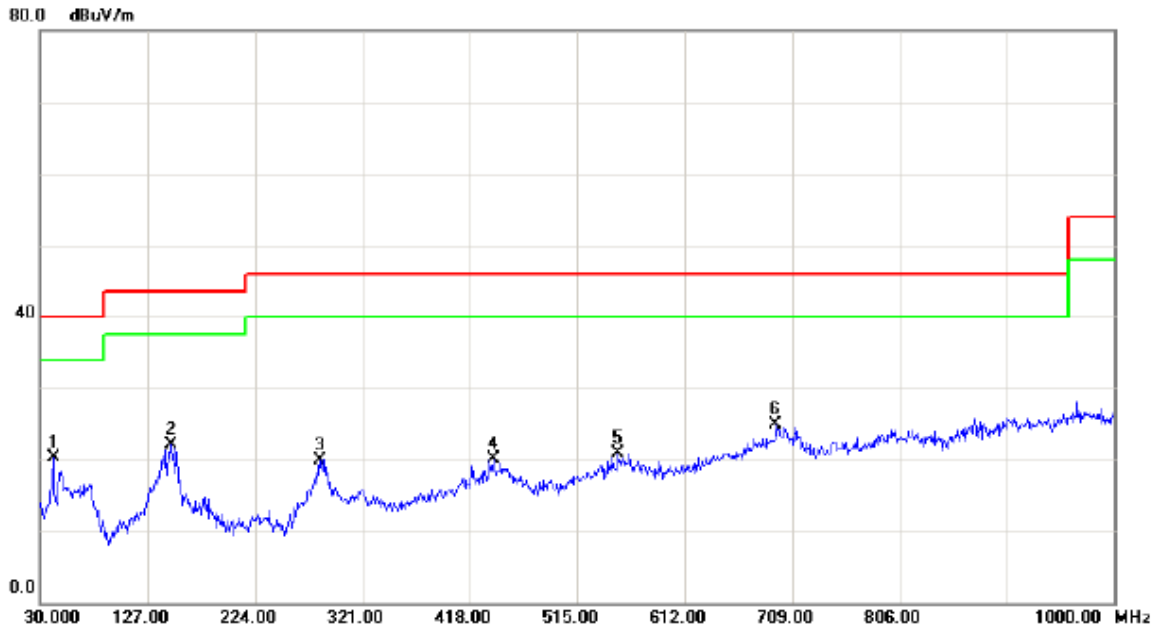

No.	Mk.	Freq. MHz	Reading Level dBuV	Correct Factor dB	Measure- ment dBuV/m	Limit dBuV/m	Over dB	Detector	Comment
1	*	41.6400	34.72	-14.51	20.21	40.00	-19.79	peak	
2		148.3400	35.93	-13.74	22.19	43.50	-21.31	peak	
3		282.2000	32.25	-12.39	19.86	46.00	-26.14	peak	
4		439.3400	29.16	-9.12	20.04	46.00	-25.96	peak	
5		551.8600	28.57	-7.67	20.90	46.00	-25.10	peak	
6		694.4500	29.85	-4.89	24.96	46.00	-21.04	peak	



Test Mode: TX 2440MHz -CH19 -1Mbps (Adapter: P2551)

Vertical

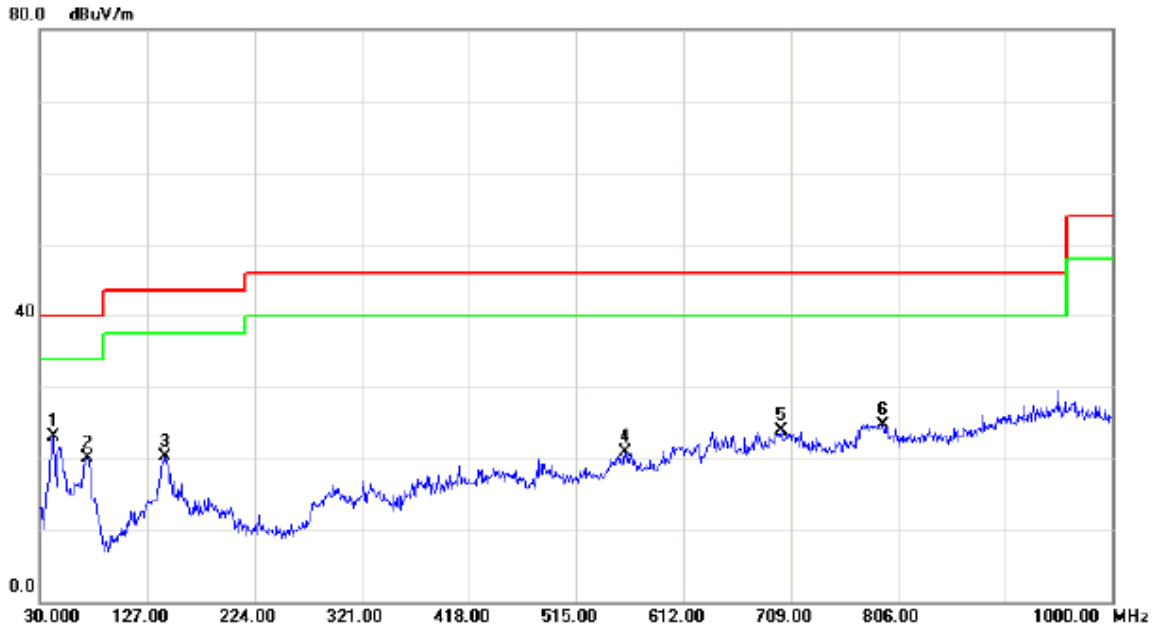

No.	Mk.	Freq. MHz	Reading Level dBuV	Correct Factor dB	Measure- ment dBuV/m	Limit dBuV/m	Over dB	Detector	Comment
1	*	41.6400	37.58	-14.51	23.07	40.00	-16.93	peak	
2		72.6800	36.68	-16.55	20.13	40.00	-19.87	peak	
3		143.4900	34.05	-13.76	20.29	43.50	-23.21	peak	
4		559.6200	28.57	-7.74	20.83	46.00	-25.17	peak	
5		700.2700	28.71	-4.81	23.90	46.00	-22.10	peak	
6		792.4200	28.16	-3.38	24.78	46.00	-21.22	peak	



Test Mode: TX 2440MHz -CH19 -1Mbps (Adapter: P2551)

Horizontal

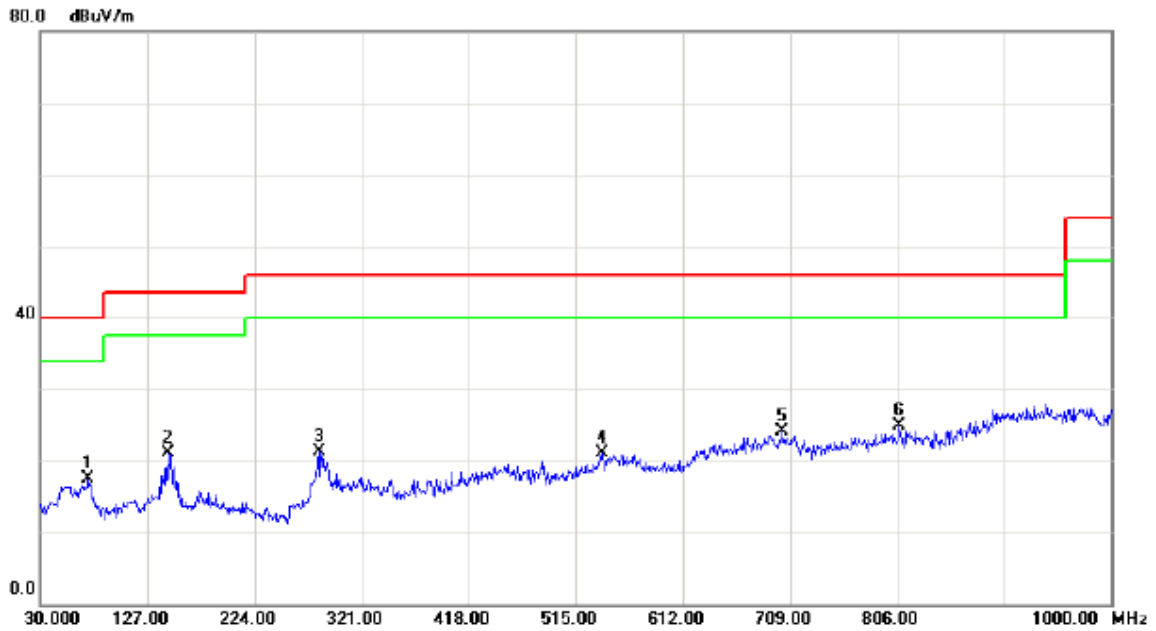

No.	Mk.	Freq. MHz	Reading Level dBuV	Correct Factor dB	Measure- ment dBuV/m	Limit dBuV/m	Over dB	Detector	Comment
1		73.6500	34.12	-16.64	17.48	40.00	-22.52	peak	
2		145.4300	34.79	-13.75	21.04	43.50	-22.46	peak	
3		282.2000	33.68	-12.39	21.29	46.00	-24.71	peak	
4		538.2800	29.44	-8.28	21.16	46.00	-24.84	peak	
5		701.2400	28.93	-4.82	24.11	46.00	-21.89	peak	
6	*	807.9400	28.05	-3.19	24.86	46.00	-21.14	peak	



Test Mode: TX 2480MHz -CH39 -1Mbps (Adapter: P2551)

Vertical

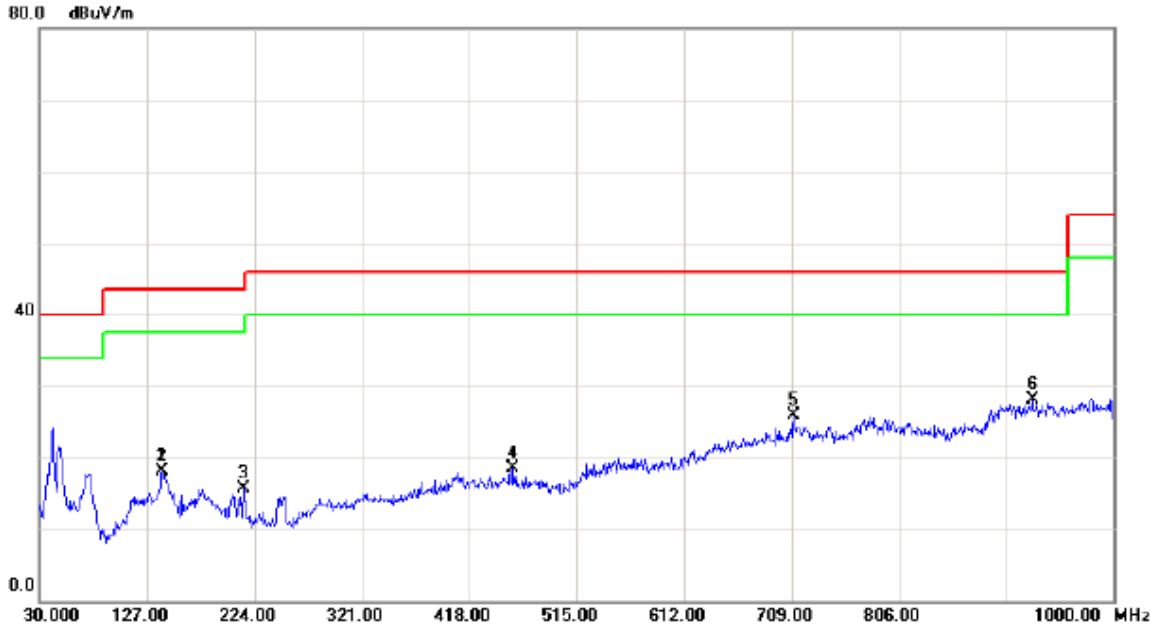

No. Mk.	Freq. MHz	Reading Level dBuV	Correct Factor dB	Measurement dBuV/m	Limit dBuV/m	Over dB	Detector	Comment
1	140.5800	31.84	-13.78	18.06	43.50	-25.44	peak	
2	140.5800	31.84	-13.78	18.06	43.50	-25.44	peak	
3	214.3000	30.94	-15.15	15.79	43.50	-27.71	peak	
4	457.7700	27.72	-9.13	18.59	46.00	-27.41	peak	
5	710.9400	30.76	-4.83	25.93	46.00	-20.07	peak	
6 *	926.2800	28.93	-0.88	28.05	46.00	-17.95	peak	



Test Mode: TX 2480MHz -CH39 -1Mbps (Adapter: P2551)

Horizontal

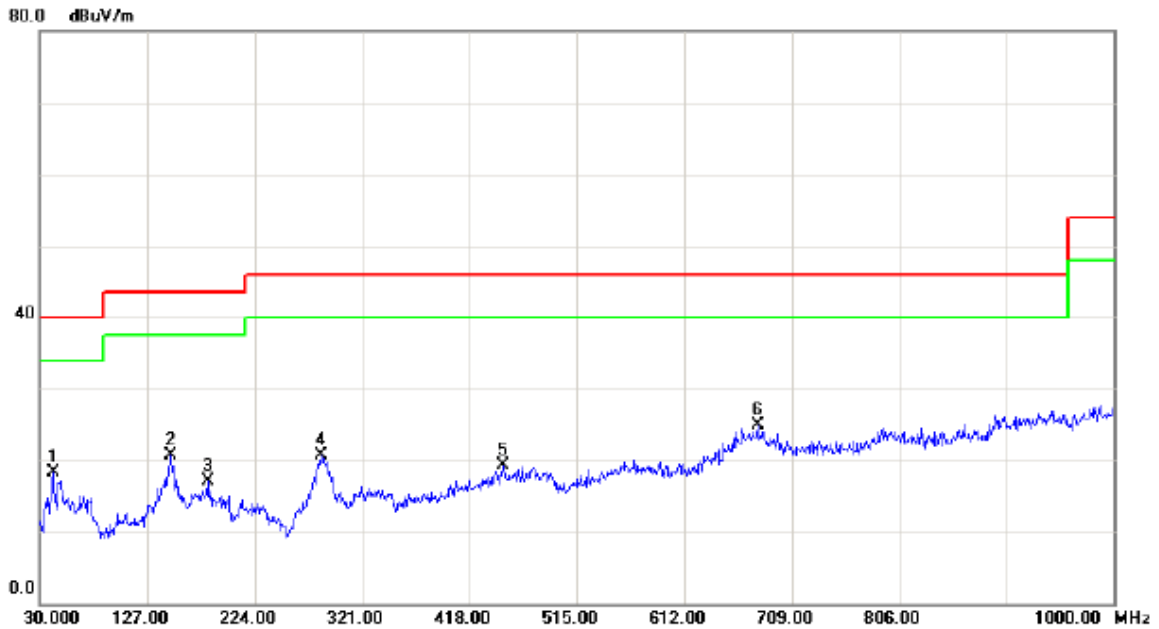

No.	Mk.	Freq. MHz	Reading Level dBuV	Correct Factor dB	Measure- ment dBuV/m	Limit dBuV/m	Over dB	Detector	Comment
1		41.6400	32.91	-14.51	18.40	40.00	-21.60	peak	
2		148.3400	34.38	-13.74	20.64	43.50	-22.86	peak	
3		181.3200	30.05	-13.04	17.01	43.50	-26.49	peak	
4		284.1400	33.04	-12.24	20.80	46.00	-25.20	peak	
5		448.0700	28.32	-8.94	19.38	46.00	-26.62	peak	
6	*	677.9600	30.14	-5.15	24.99	46.00	-21.01	peak	



4.2.8 TEST RESULTS (ABOVE 1000 MHZ)

Remark:

- (1) All readings are Peak unless otherwise stated QP in column of 『Note』 . Peak denotes that the Peak reading compliance with the QP Limits and then QP Mode measurement didn't perform ◦
- (2) Measuring frequency range from 30MHz to 1000MHz or the 10th harmonic of highest fundamental frequency ◦ "F" denotes fundamental frequency; "H" denotes spurious frequency. "E" denotes band edge frequency. (This judgment method includes the Band Edge Requirement.)
- (3) Radiated emissions measured in frequency range above 1000MHz were made with an instrument using Peak detector mode and AV detector mode of the emission ◦
- (4) Data of measurement within this frequency range shown " * " in the table above means the reading of emissions are attenuated more than 20dB below the permissible limits or the field strength is too small to be measured.
- (5) A preamp and high pass filter were used for this test in order to provide sufficient measurement sensitivity.
- (6) EUT Orthogonal Axis:
"X" - denotes Laid on Table ; "Y" - denotes Vertical Stand ; "Z" - denotes Side Stand
- (7) During the measurements above 1 GHz it is taken care of that the EUT is always within the 3 dB cone of radiation BW of the used antenna



Test Mode : TX 2402MHz -CH00 -1Mbps

Freq. (MHz)	Ant.Pol. H/V	Reading		Ant./CF CF(dB)	Act.		Limit		Note
		Peak (dBuV)	AV (dBuV)		Peak (dBuV/m)	AV (dBuV/m)	Peak (dBuV/m)	AV (dBuV/m)	
2390.00	V	22.84	13.00	34.09	56.93	47.09	74.00	54.00	X/E
2401.96	V	62.32	55.82	34.12	96.44	89.94			X/F
4804.00	V	38.42	29.27	6.38	44.80	35.65	74.00	54.00	X/H

Freq. (MHz)	Ant.Pol. H/V	Reading		Ant./CF CF(dB)	Act.		Limit		Note
		Peak (dBuV)	AV (dBuV)		Peak (dBuV/m)	AV (dBuV/m)	Peak (dBuV/m)	AV (dBuV/m)	
2390.00	H	23.12	12.93	34.09	57.21	47.02	74.00	54.00	X/E
2402.15	H	61.79	54.95	34.12	95.91	89.07			X/F
4804.00	H	37.23	29.29	6.38	43.61	35.67	74.00	54.00	X/H

Freq. (MHz)	Ant.Pol. H/V	Reading		Ant./CF CF(dB)	Act.		Limit		Note
		Peak (dBuV)	AV (dBuV)		Peak (dBuV/m)	AV (dBuV/m)	Peak (dBuV/m)	AV (dBuV/m)	
2440.12	V	65.44	58.71	34.24	99.68	92.95			X/F
4880.00	V	38.14	29.05	6.61	44.75	35.66	74.00	54.00	X/H

Freq. (MHz)	Ant.Pol. H/V	Reading		Ant./CF CF(dB)	Act.		Limit		Note
		Peak (dBuV)	AV (dBuV)		Peak (dBuV/m)	AV (dBuV/m)	Peak (dBuV/m)	AV (dBuV/m)	
2440.12	H	64.74	57.82	34.24	98.98	92.06			X/F
4880.00	H	37.02	29.03	6.61	43.63	35.64	74.00	54.00	X/H

Freq. (MHz)	Ant.Pol. H/V	Reading		Ant./CF CF(dB)	Act.		Limit		Note
		Peak (dBuV)	AV (dBuV)		Peak (dBuV/m)	AV (dBuV/m)	Peak (dBuV/m)	AV (dBuV/m)	
2479.95	V	63.14	56.18	34.36	97.50	90.54			X/F
2483.50	V	23.36	12.99	34.37	57.73	47.36	74.00	54.00	X/E
4960.00	V	37.85	28.52	6.83	44.68	35.35	74.00	54.00	X/H

Freq. (MHz)	Ant.Pol. H/V	Reading		Ant./CF CF(dB)	Act.		Limit		Note
		Peak (dBuV)	AV (dBuV)		Peak (dBuV/m)	AV (dBuV/m)	Peak (dBuV/m)	AV (dBuV/m)	
2479.89	H	63.06	56.07	34.36	97.42	90.43			X/F
2483.50	H	23.28	12.96	34.37	57.65	47.33	74.00	54.00	X/E
4960.00	H	37.08	28.97	6.83	43.91	35.80	74.00	54.00	X/H



TX CH00 (Above 1000 MHz, Vertical)

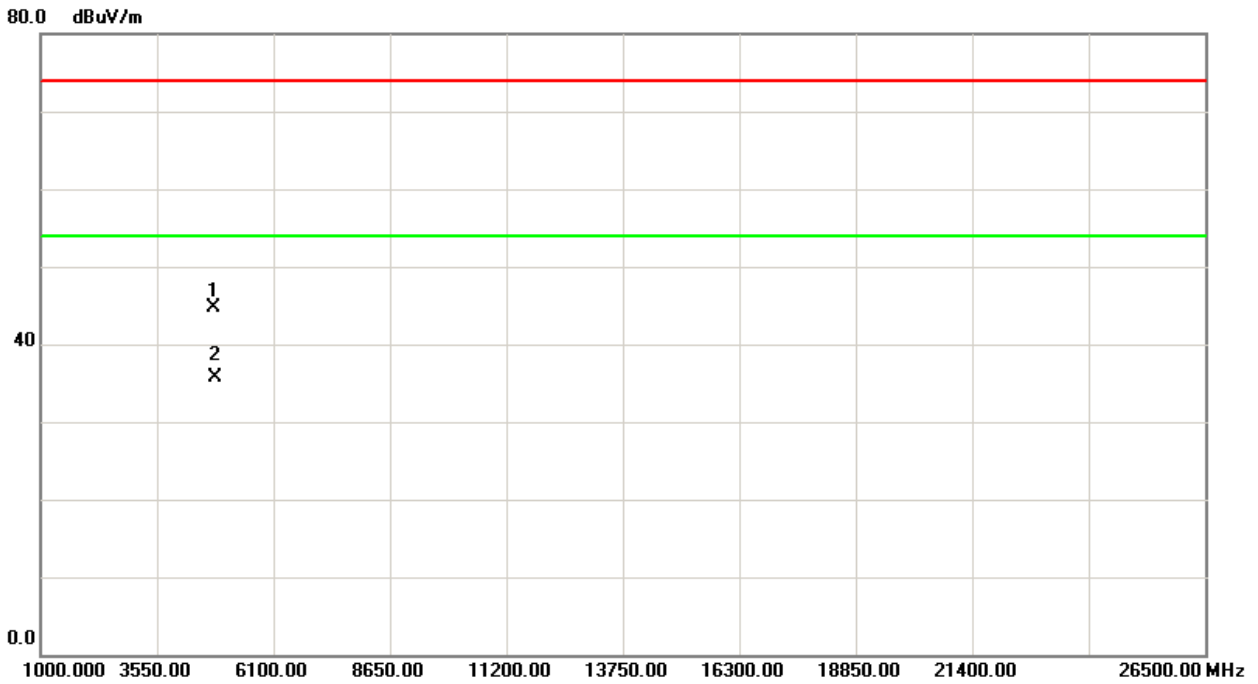
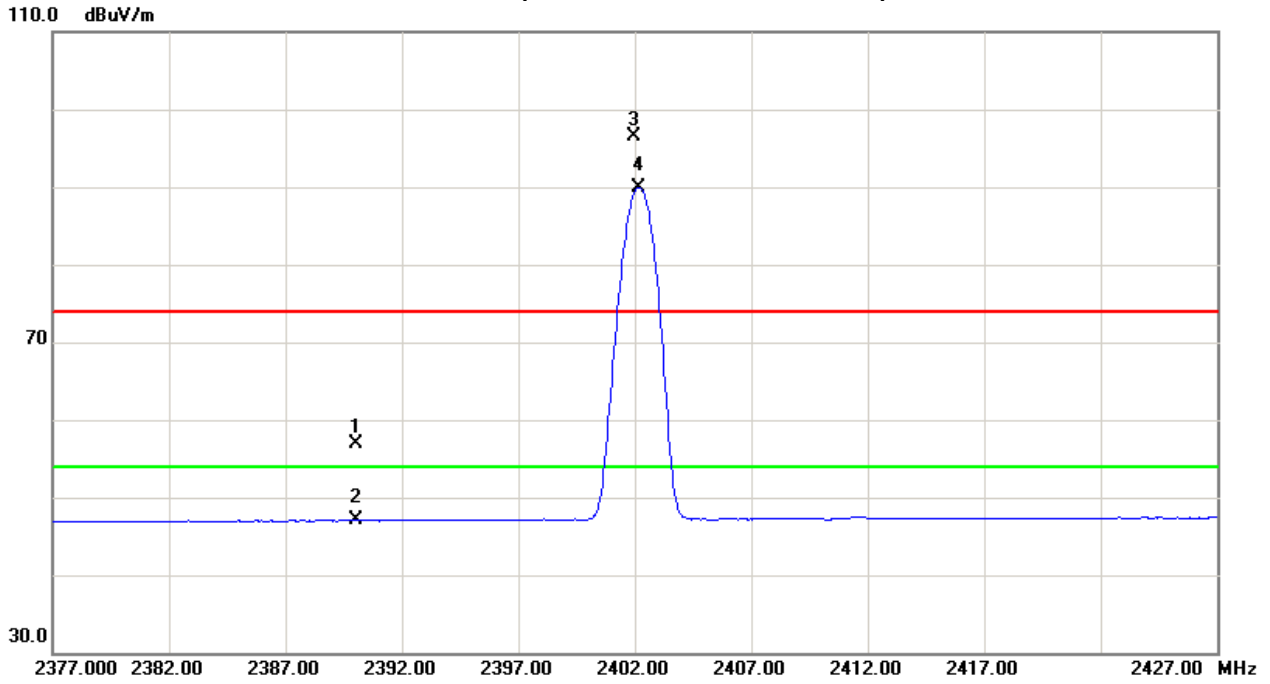



TX CH00 (Above 1000 MHz, Horizontal)

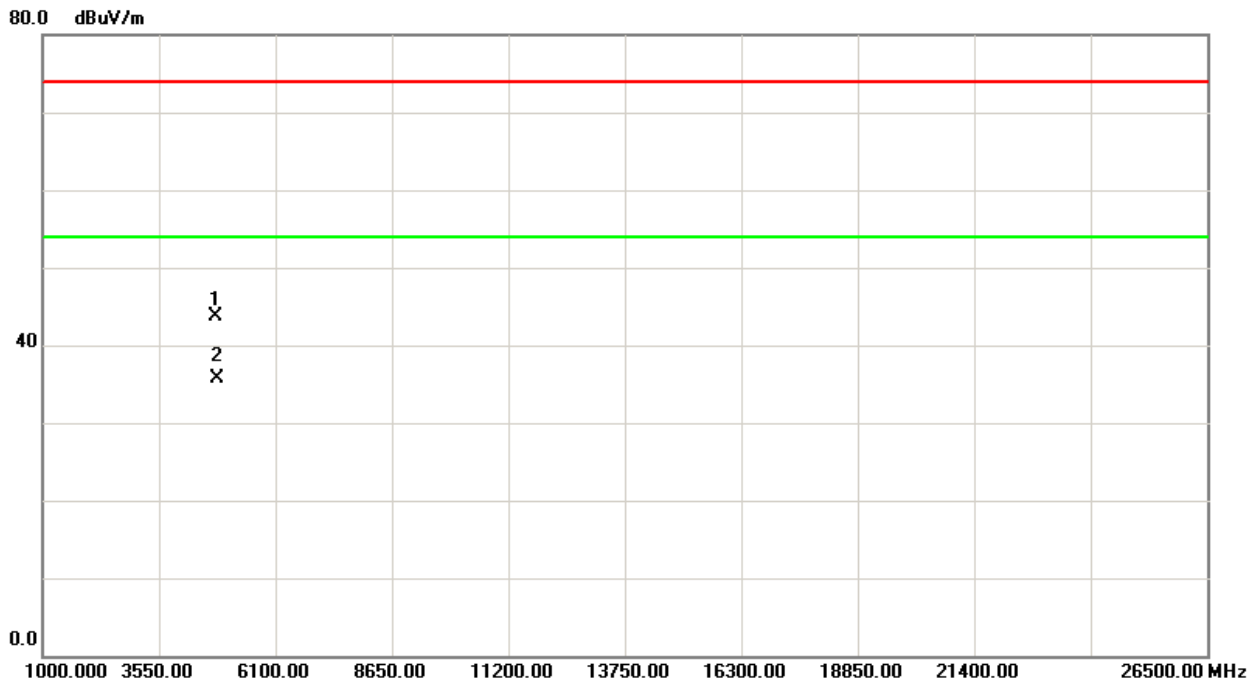
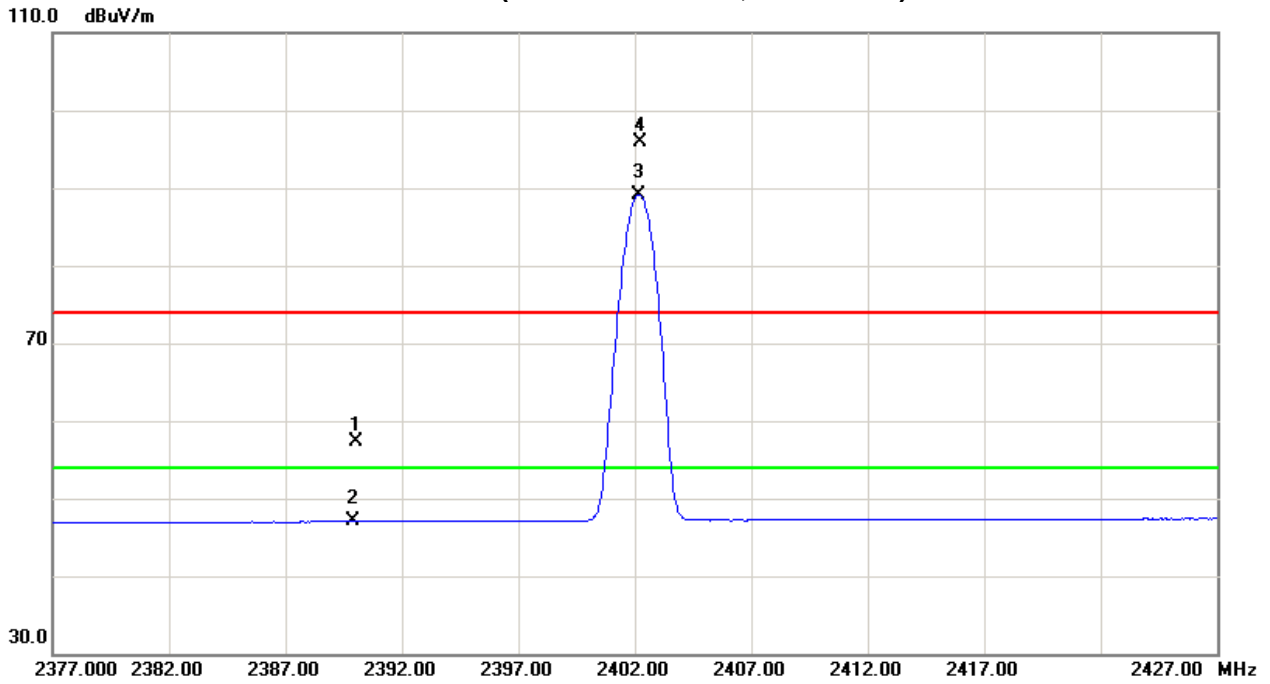



TX CH19 (Above 1000 MHz, Vertical)

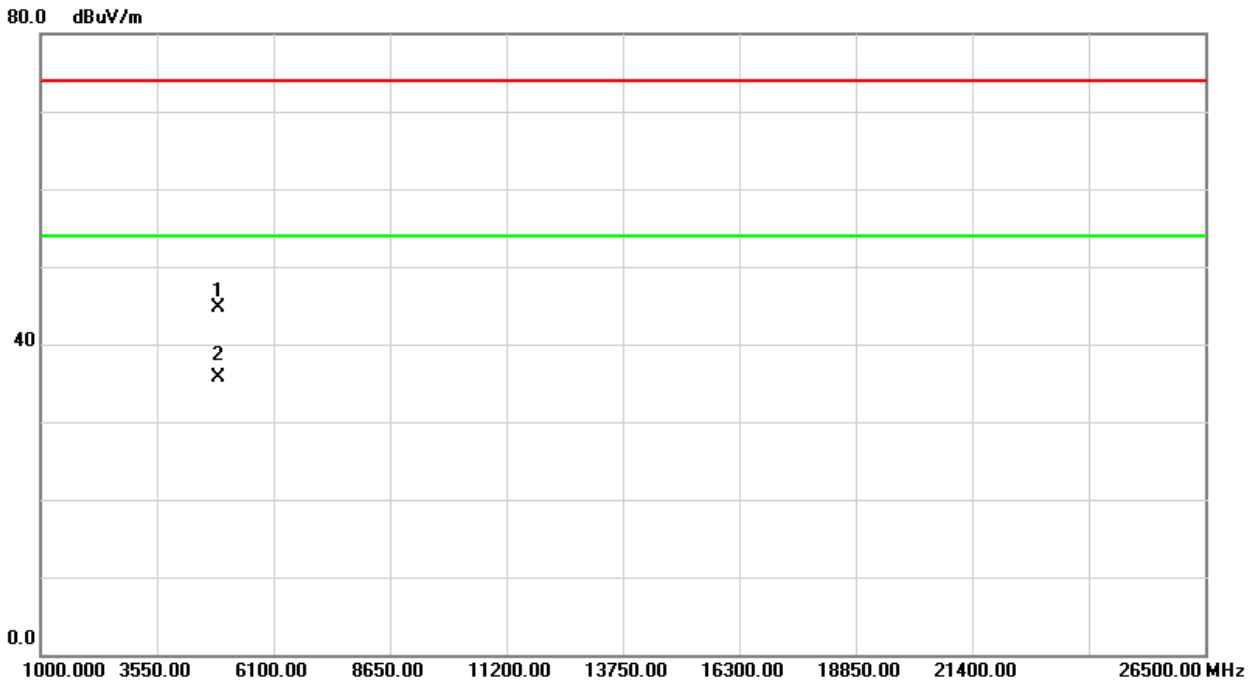
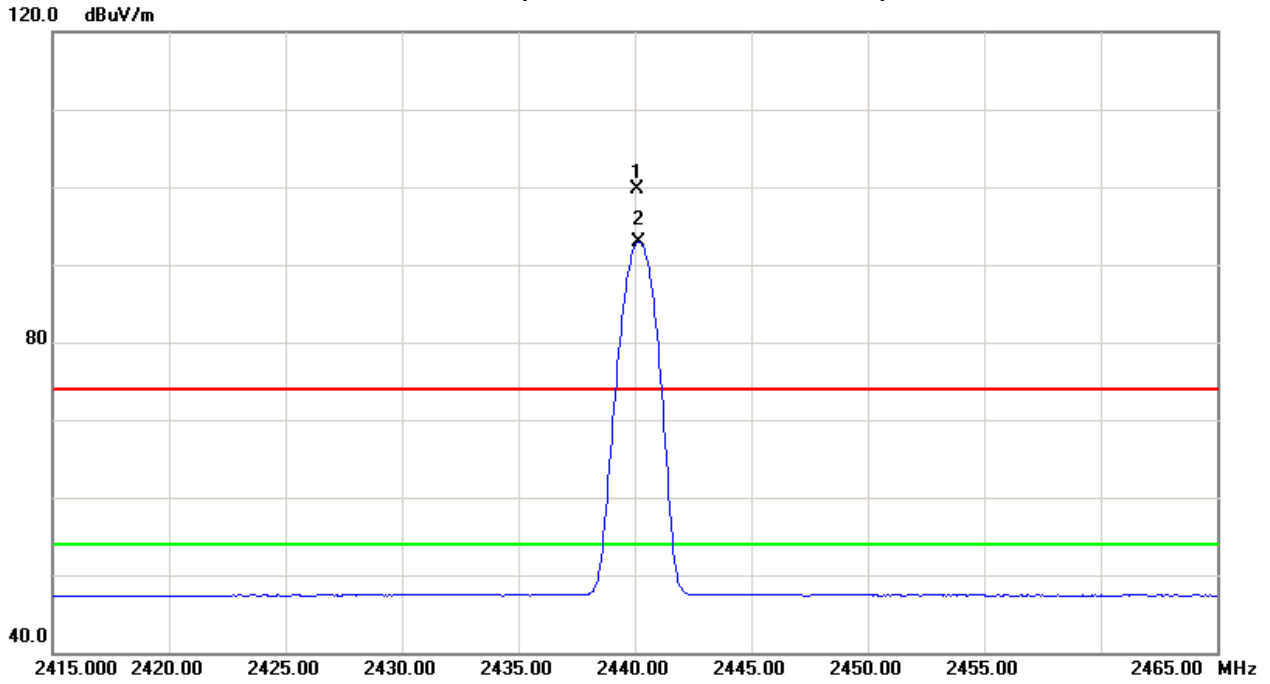



TX CH19 (Above 1000 MHz, Horizontal)

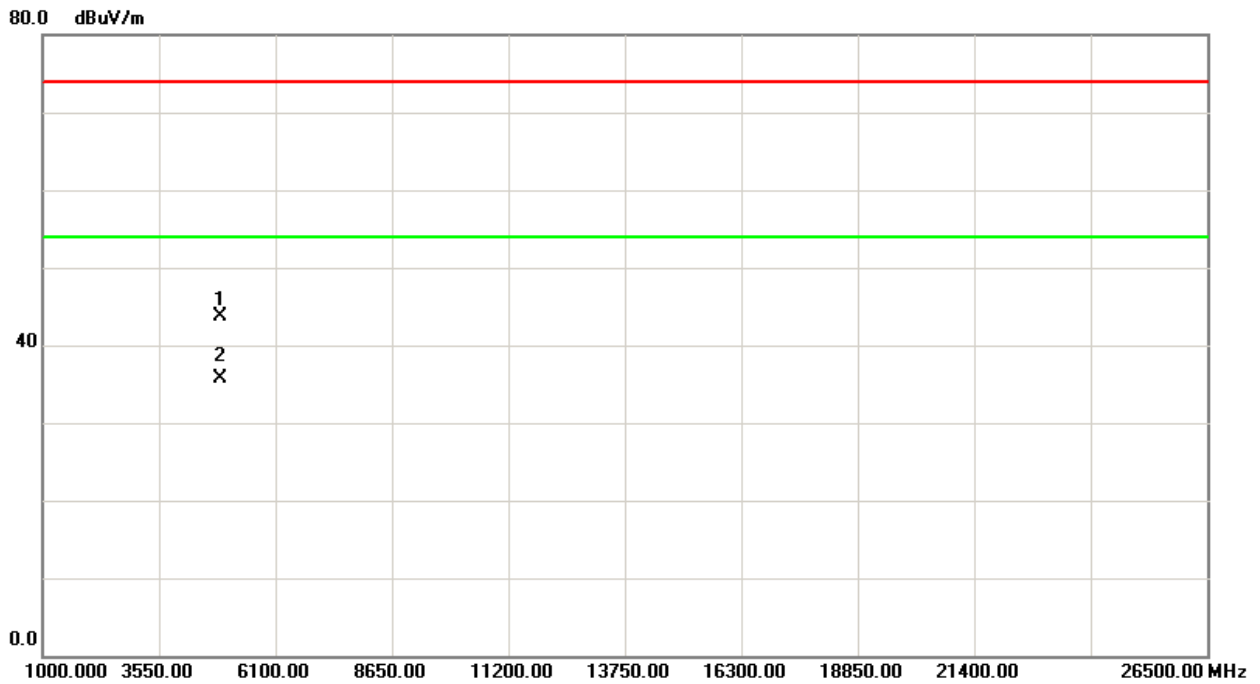
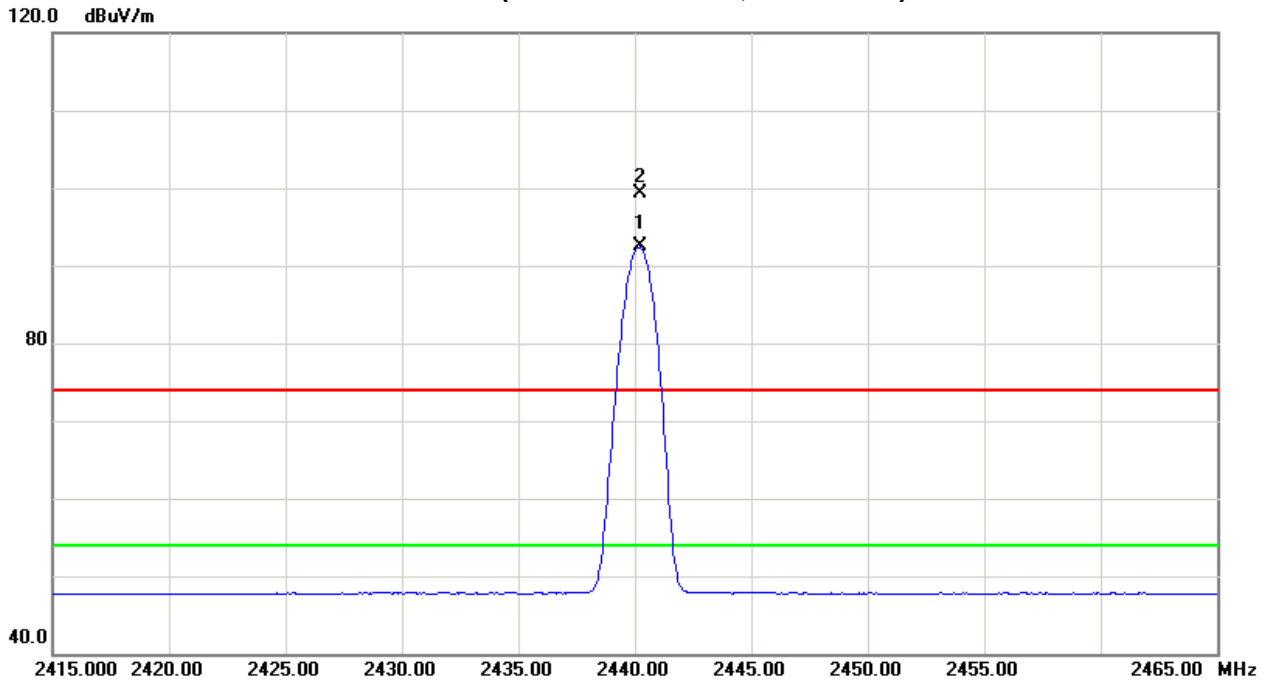



TX CH39 (Above 1000 MHz, Vertical)

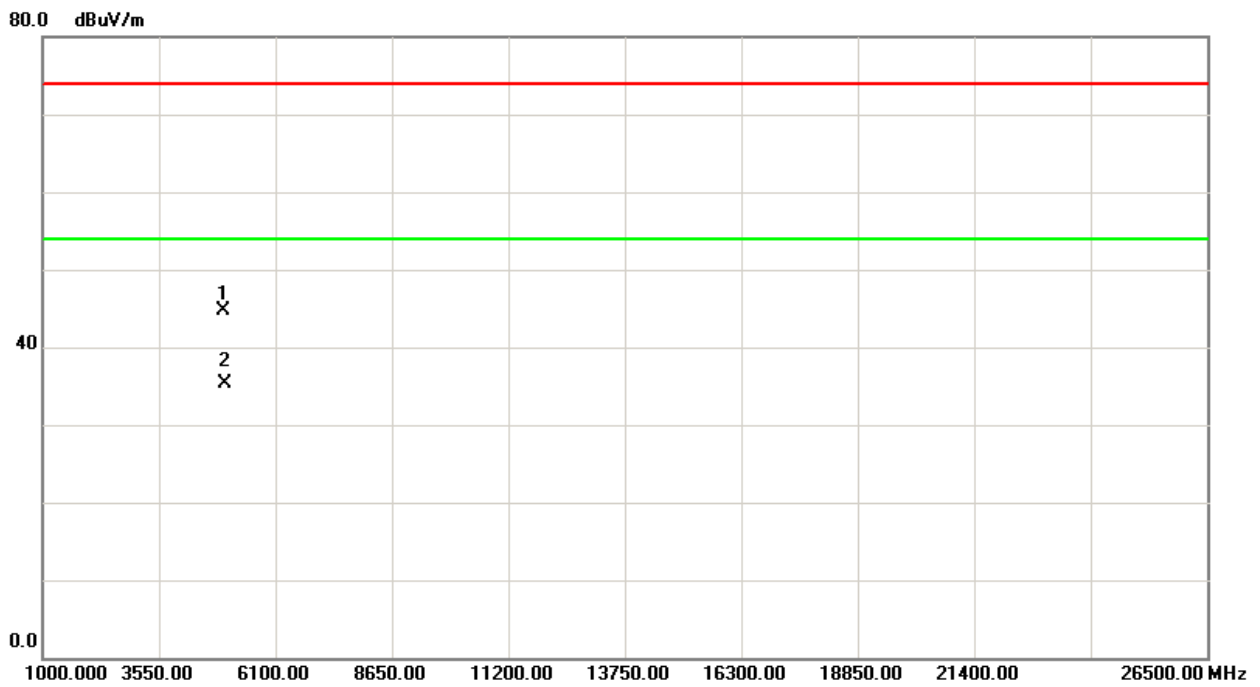
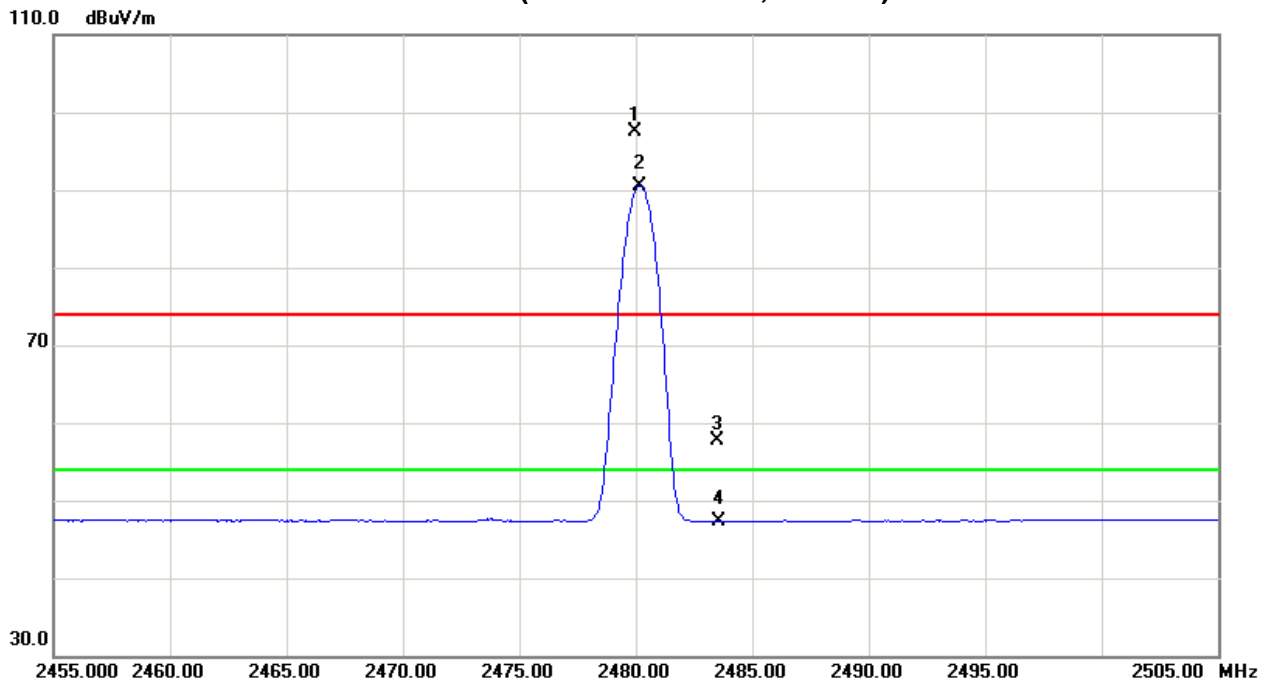



TX CH39 (Above 1000 MHz, Horizontal)

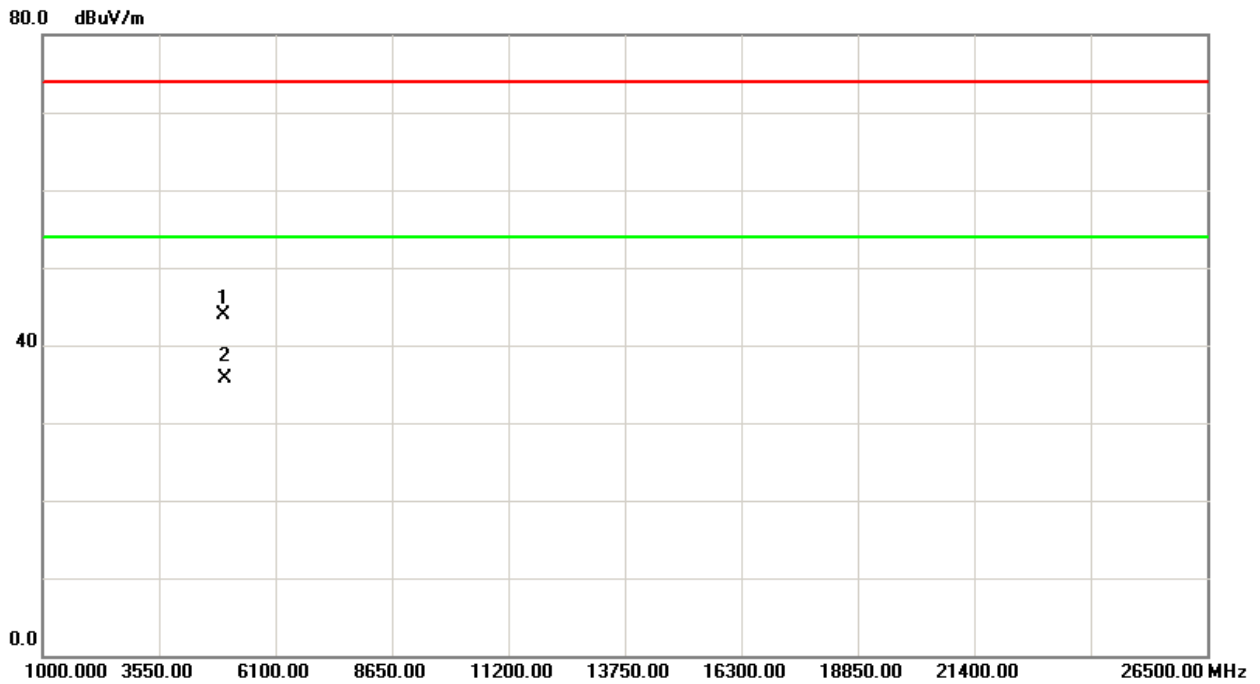
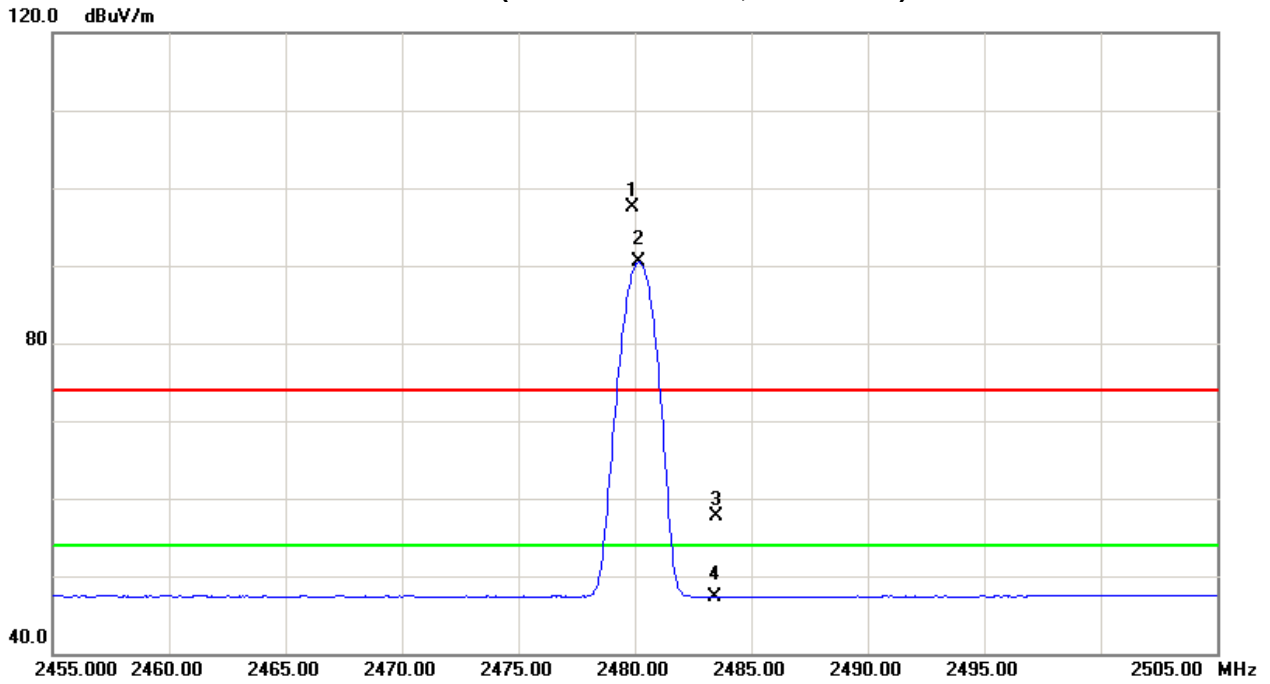



5. BANDWIDTH TEST

5.1 Applied procedures / limit

FCC Part15 (15.247) , Subpart C/ RSS-GEN and RSS-210				
Section	Test Item	Limit	Frequency Range (MHz)	Result
15.247(a)(2) RSS-GEN section 4.6.1 RSS-210 Annex 8 (A8.2(a))	Bandwidth	$\geq 500\text{KHz}$ (6dB bandwidth)	2400-2483.5	PASS

5.1.1 TEST PROCEDURE

- a. The EUT was directly connected to the spectrum analyzer and antenna output port as show in the block diagram below,
- b. Spectrum Setting : RBW= 100KHz, VBW=300KHz, Sweep time = 2.5 ms.

5.1.2 DEVIATION FROM STANDARD

No deviation.

5.1.3 TEST SETUP



5.1.4 EUT OPERATION CONDITIONS

The EUT tested system was configured as the statements of 4.1.6 Unless otherwise a special operating condition is specified in the follows during the testing.

5.1.5 EUT TEST CONDITIONS

Temperature: 25°C
 Relative Humidity: 55%
 Test Voltage: 120V/60Hz



5.1.6 TEST RESULTS

CH00, CH19, CH39 - 1Mbps				
Test Channel	Frequency (MHz)	6dB Bandwidth (MHz)	99% OBW (MHz)	LIMIT (MHz)
CH00	2402	0.66	1.04	>=500KHz
CH19	2440	0.65	1.04	>=500KHz
CH39	2480	0.67	1.04	>=500KHz

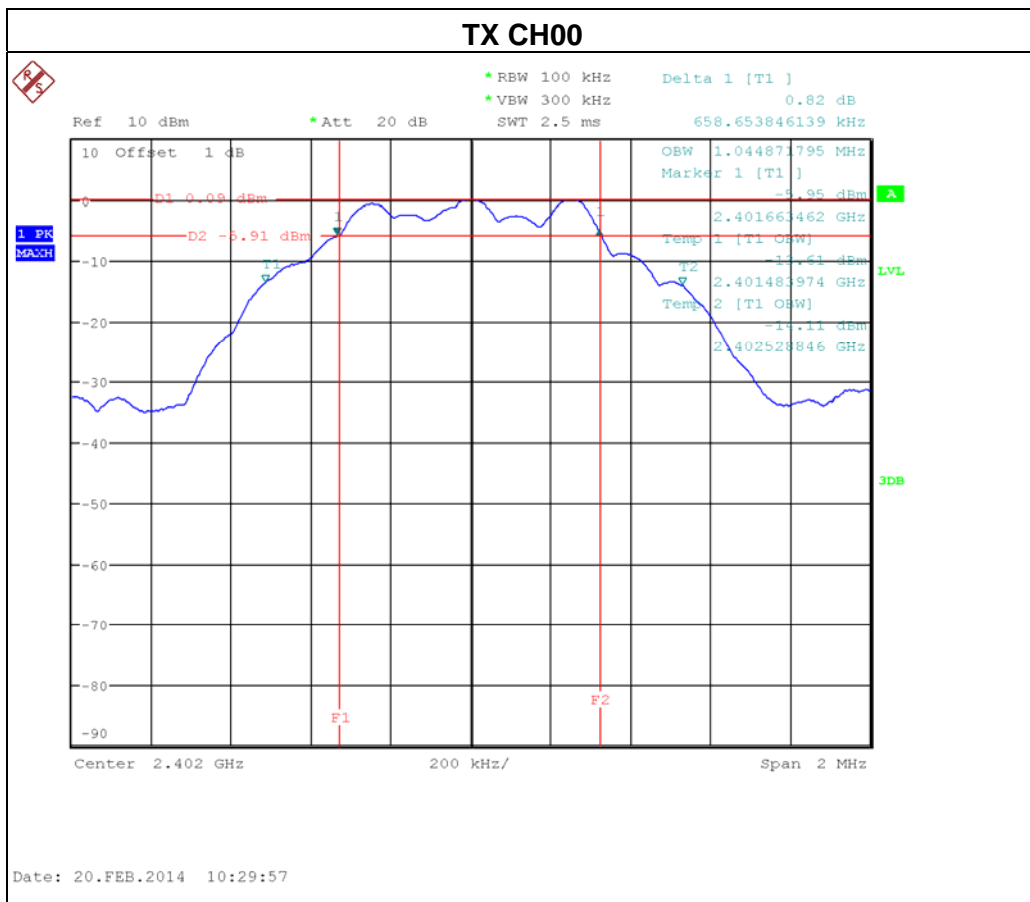

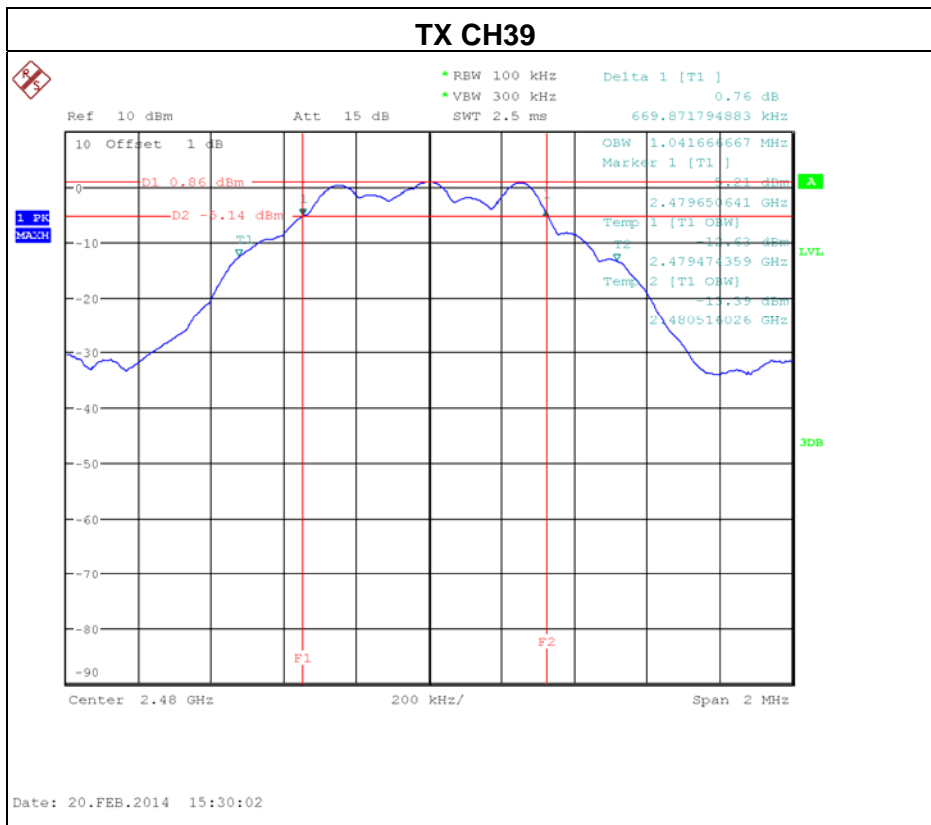
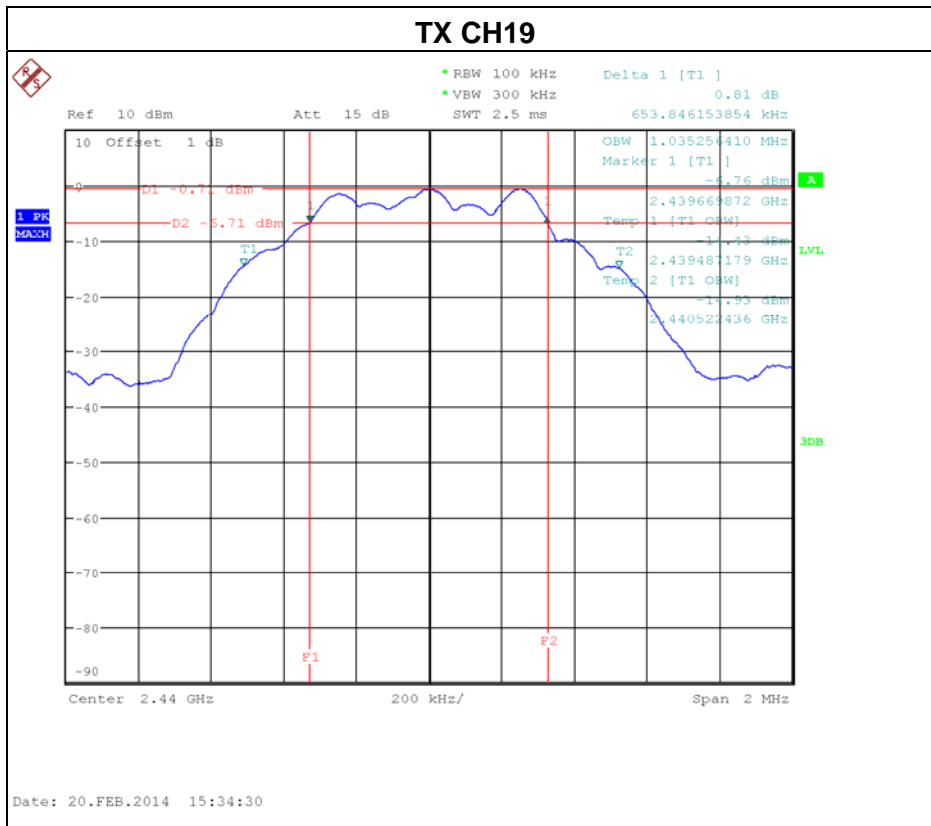



6. MAXIMUM OUTPUT POWER TEST

6.1 Applied procedures / limit

FCC Part15 (15.247) , Subpart C/ RSS-210				
Section	Test Item	Limit	Frequency Range (MHz)	Result
15.247(b)(3) RSS-210 Annex 8.4(4)	Maximum Output Power	1 watt or 30dBm	2400-2483.5	PASS

6.1.1 TEST PROCEDURE

- a. The EUT was directly connected to the power meter and antenna output port as show in the block diagram below,
- b. The maximum peak conducted output power was performed in accordance with method 9.3.1 of FCC KDB 558074

6.1.2 DEVIATION FROM STANDARD

No deviation.

6.1.3 TEST SETUP



6.1.4 EUT OPERATION CONDITIONS

The EUT tested system was configured as the statements of 4.1.6 Unless otherwise a special operating condition is specified in the follows during the testing. Transmit output power was measured while the host equipment supply voltage was varied from 85 % to 115 % of the nominal rated supply voltage. No change in transmit output power was observed.

6.1.5 EUT TEST CONDITIONS

Temperature: 25°C
 Relative Humidity: 55%
 Test Voltage: 120V/60Hz



6.1.6 TEST RESULTS

Test Mode : CH00, CH19, CH39 - 1Mbps				
Test Channel	Frequency (MHz)	Peak Output Power (dBm)	LIMIT (dBm)	LIMIT (W)
CH00	2402	1.73	30	1
CH19	2440	0.83	30	1
CH39	2480	2.45	30	1



7. ANTENNA CONDUCTED SPURIOUS EMISSION

7.1 Applied procedures / limit

20dB in any 100 kHz bandwidth outside the operating frequency band. In case the emission fall within the restricted band specified 15.205(a) & RSS-210 section 2.2& Annex 8 (A8.5), then the 15.209(a) & RSS-GEN limit in the table below has to be followed.

Frequency (MHz)	Field Strength (microvolts/meter)	Measurement Distance (meters)
0.009~0.490	2400/F(KHz)	300
0.490~1.705	24000/F(KHz)	30
1.705~30.0	30	30
30~88	100	3
88~216	150	3
216~960	200	3
960~1000	500	3

7.1.1 TEST PROCEDURE

- a. The EUT was directly connected to the spectrum analyzer and antenna output port as show in the block diagram below,
- b. Spectrum Setting : RBW= 100KHz, VBW=300KHz, Sweep time = 10 ms.

7.1.2 DEVIATION FROM STANDARD

No deviation.

7.1.3 TEST SETUP



7.1.4 EUT OPERATION CONDITIONS

The EUT tested system was configured as the statements of 4.1.6 Unless otherwise a special operating condition is specified in the follows during the testing.

7.1.5 EUT OPERATION CONDITIONS

Temperature: 25°C
 Relative Humidity: 55%
 Test Voltage: 120V/60Hz

7.1.6 TEST RESULTS

Test Mode :	CH00, CH19 , CH39 - 1Mbps
-------------	---------------------------

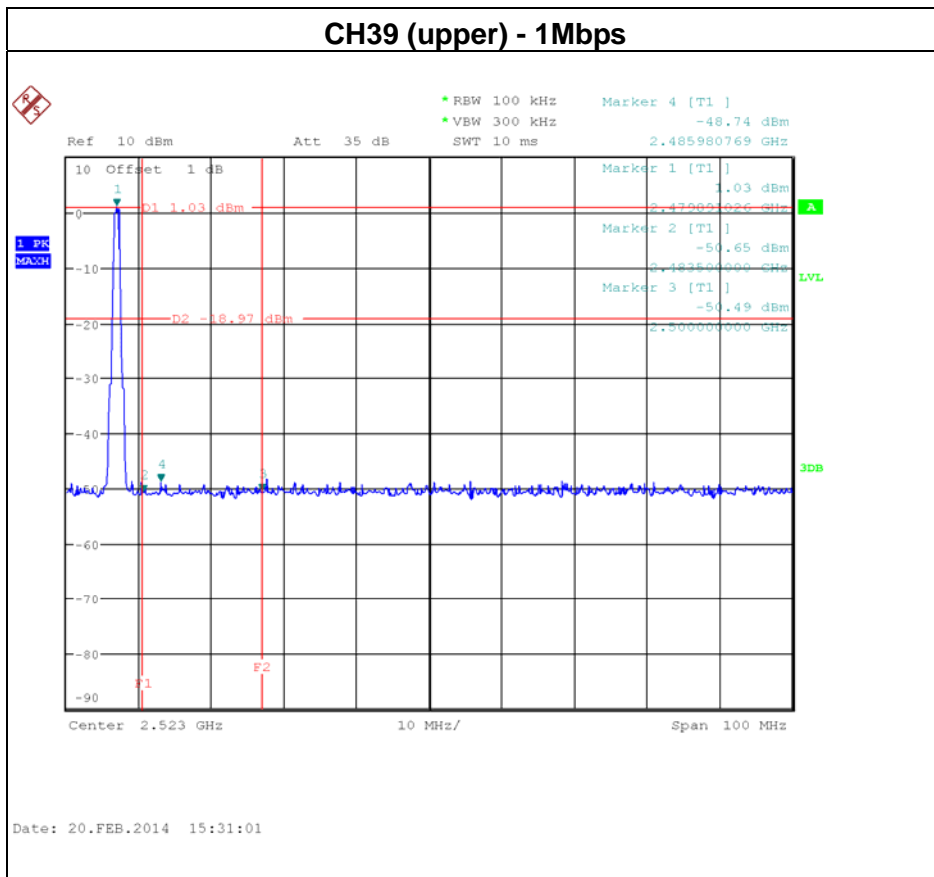
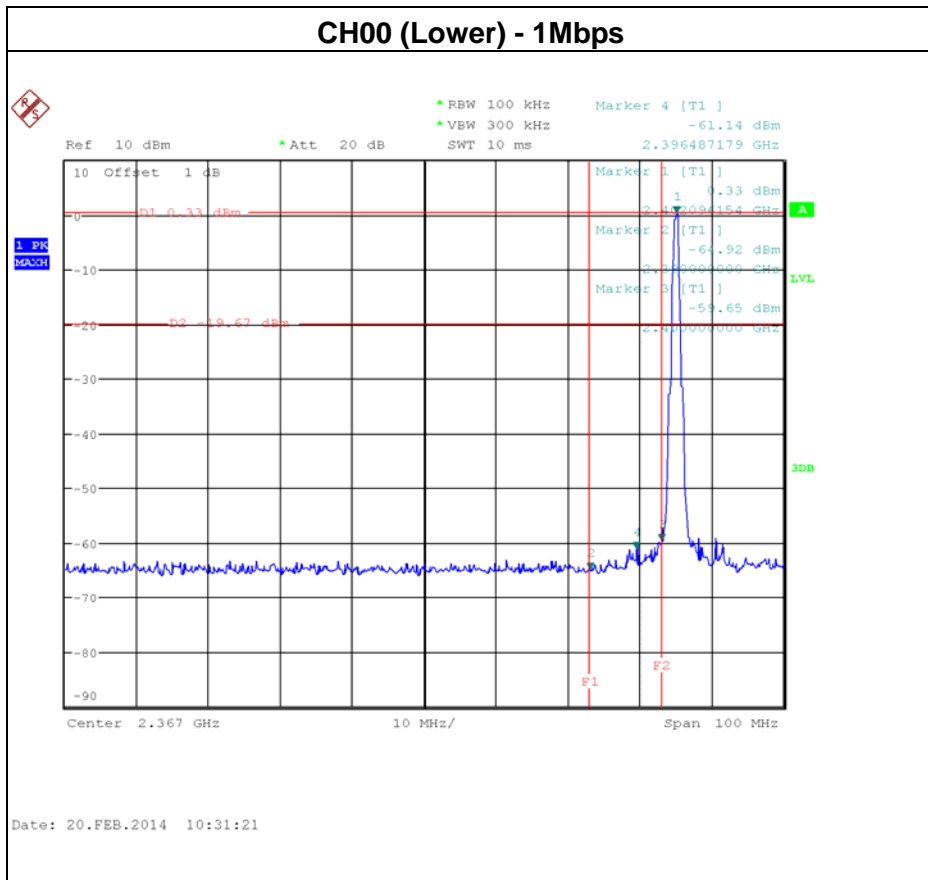

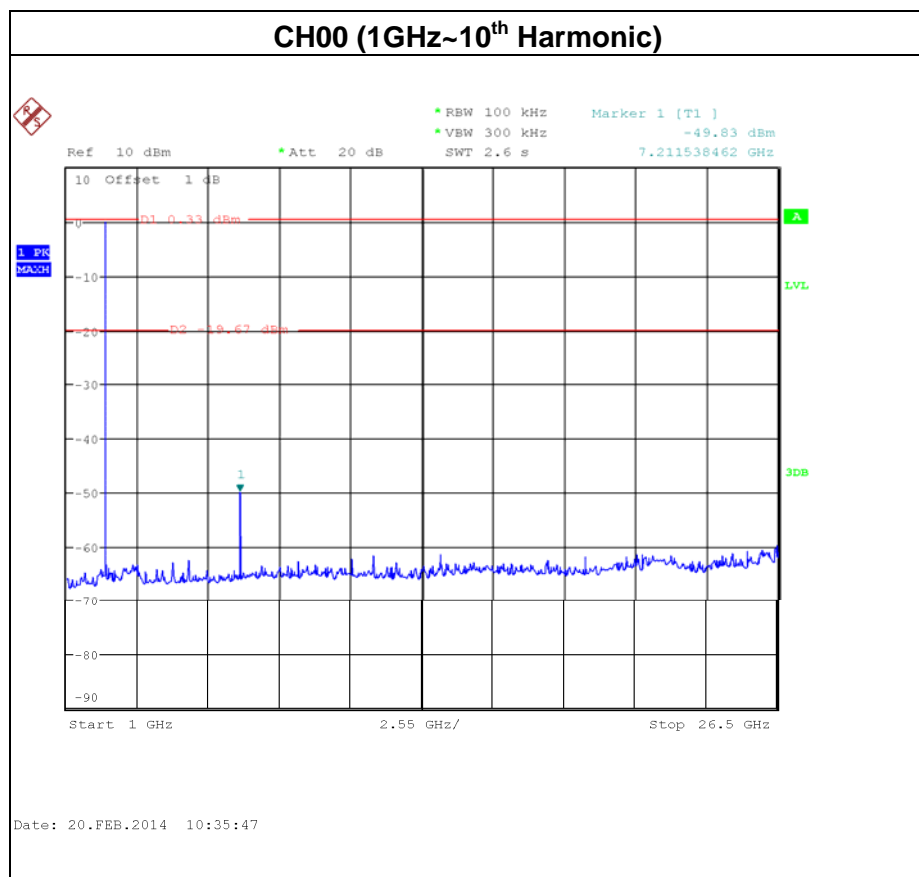
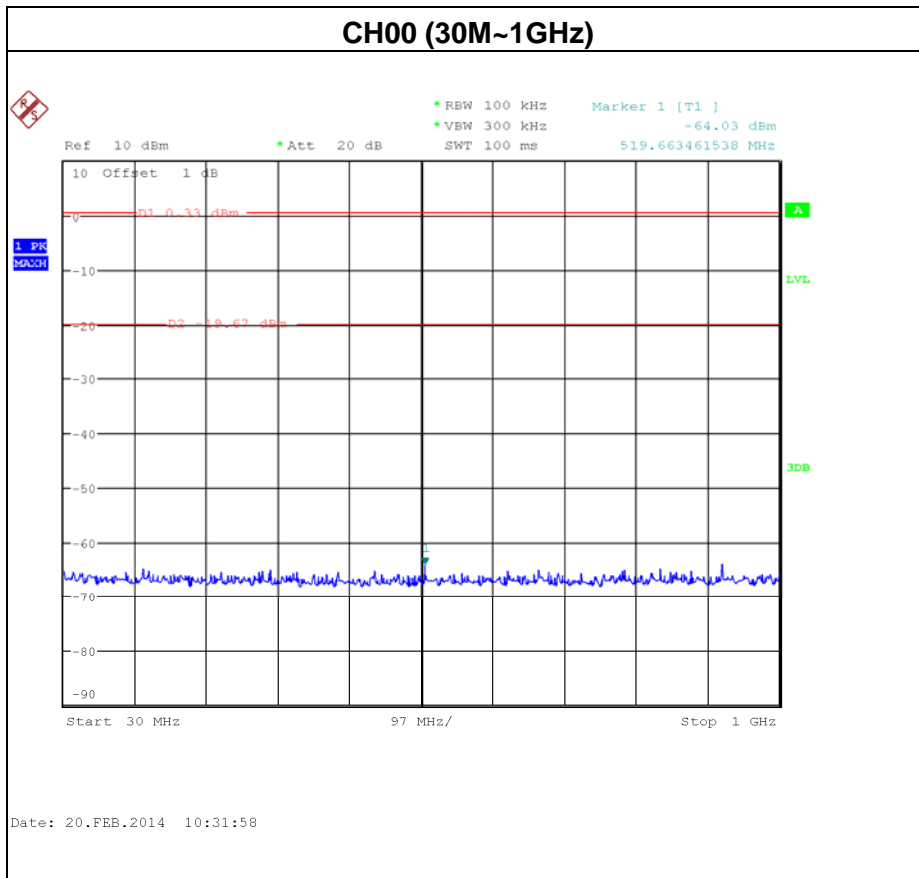

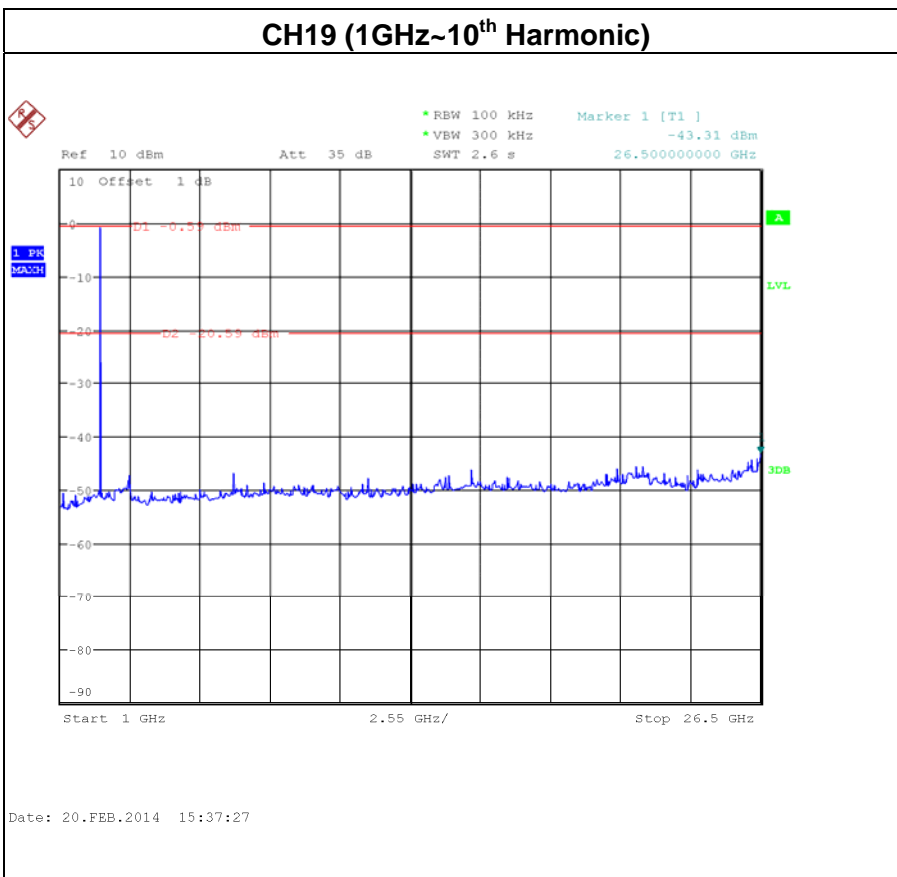
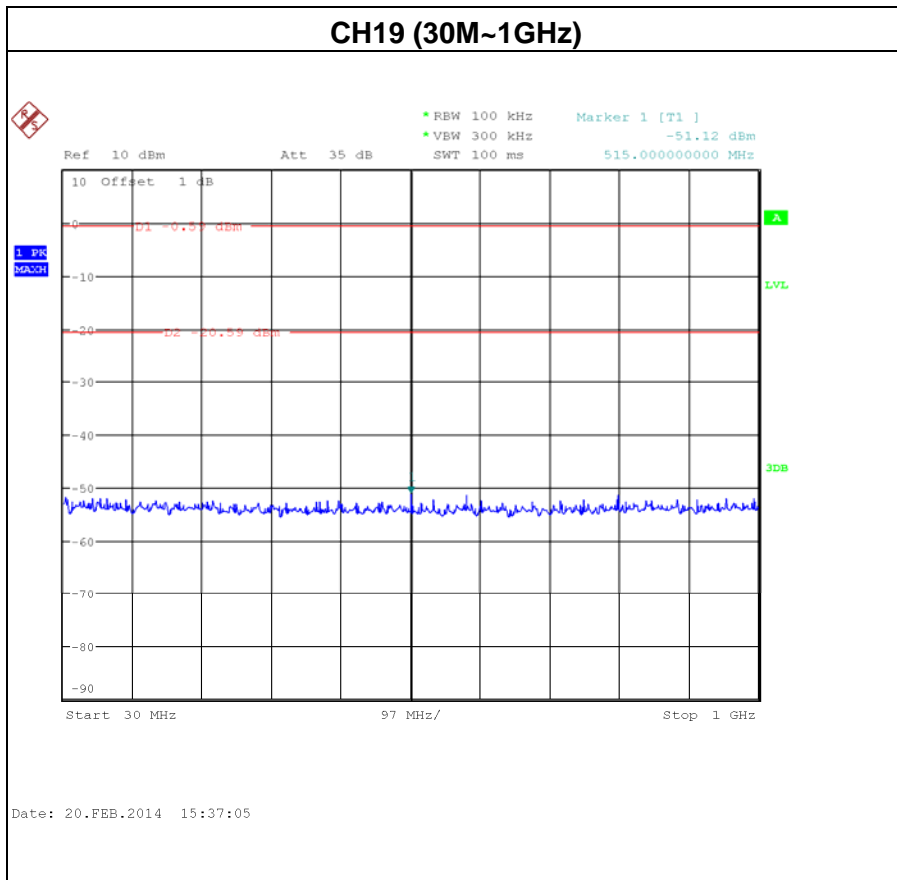

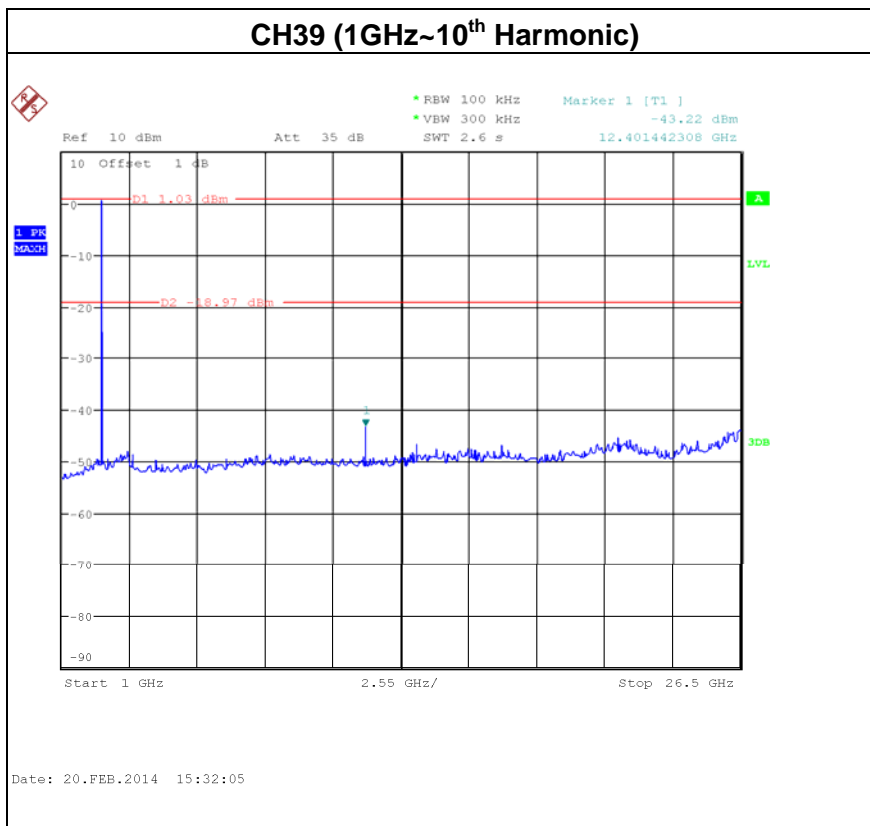
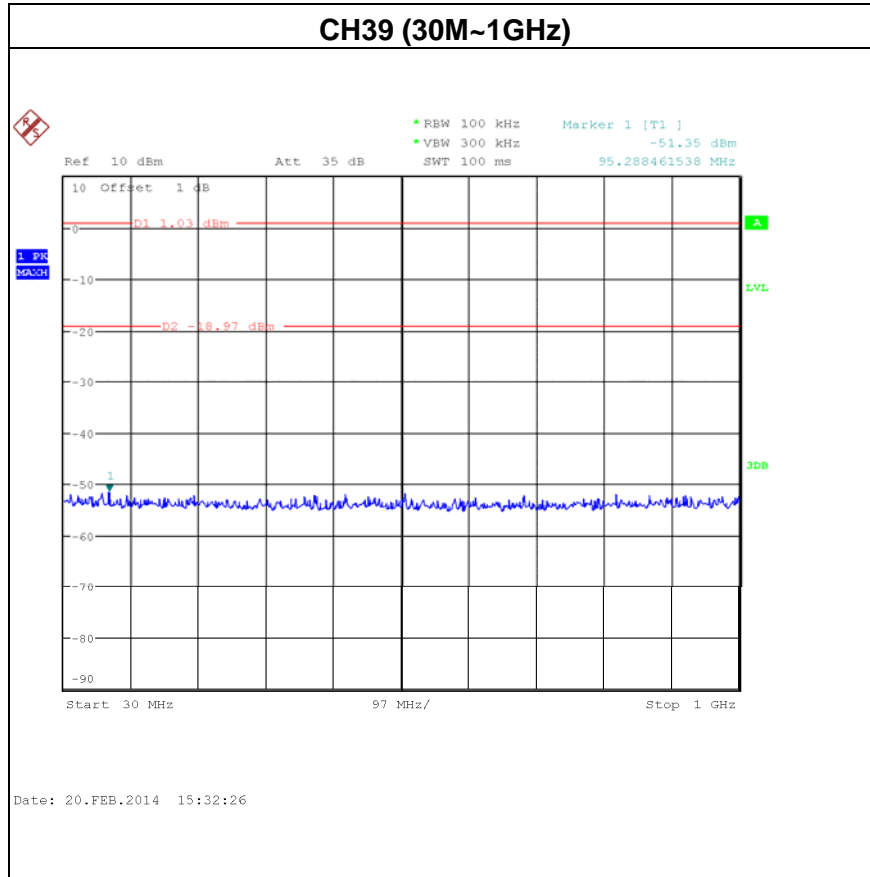



8. POWER SPECTRAL DENSITY TEST

8.1 Applied procedures / limit

FCC Part15 (15.247) , Subpart C / RSS-210				
Section	Test Item	Limit	Frequency Range (MHz)	Result
15.247(e) RSS-210 Annex 8(A8.2(b))	Power Spectral Density	8 dBm (in any 3KHz)	2400-2483.5	PASS

8.1.1 TEST PROCEDURE

- a. The EUT was directly connected to the spectrum analyzer and antenna output port as show in the block diagram below,
- b. Spectrum Setting: RBW=3KHz, VBW=10 KHz, Sweep time = auto.

8.1.2 DEVIATION FROM STANDARD

No deviation.

8.1.3 TEST SETUP

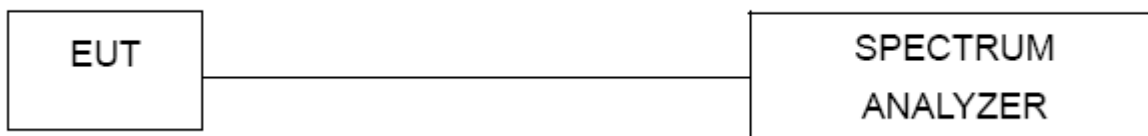

8.1.4 EUT OPERATION CONDITIONS

The EUT tested system was configured as the statements of 4.1.6 Unless otherwise a special operating condition is specified in the follows during the testing.

8.1.5 EUT TEST CONDITIONS

Temperature: 25°C
 Relative Humidity: 55%
 Test Voltage: 120V/60Hz



8.1.6 TEST RESULTS

Test Mode : CH00, CH19, CH39 -1Mbps			
Test Channel	Frequency (MHz)	Power Density (dBm)	LIMIT (dBm)
CH00	2402	-2.51	8
CH19	2440	-3.26	8
CH39	2480	-1.91	8

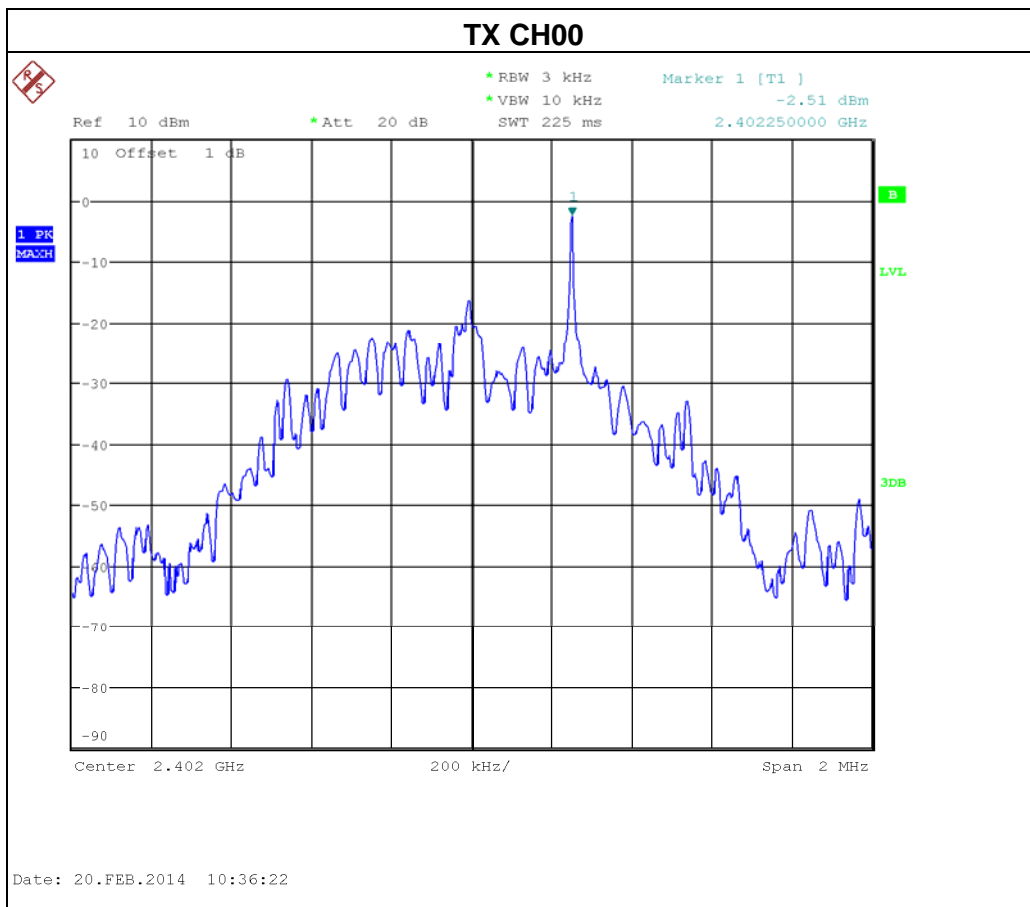

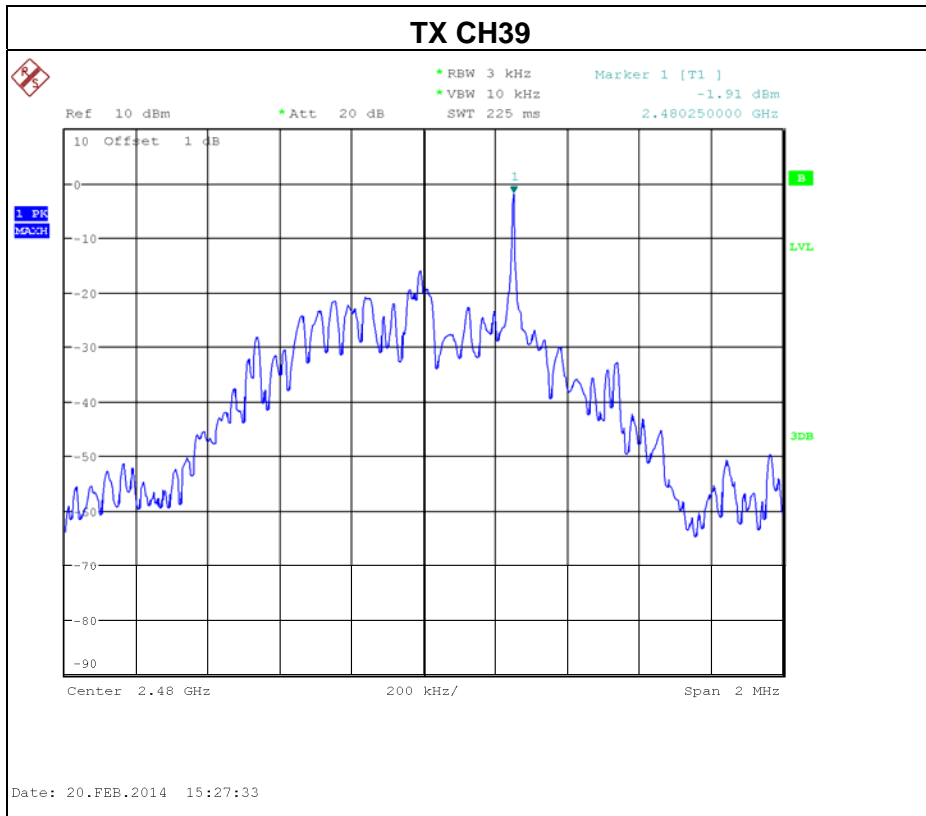
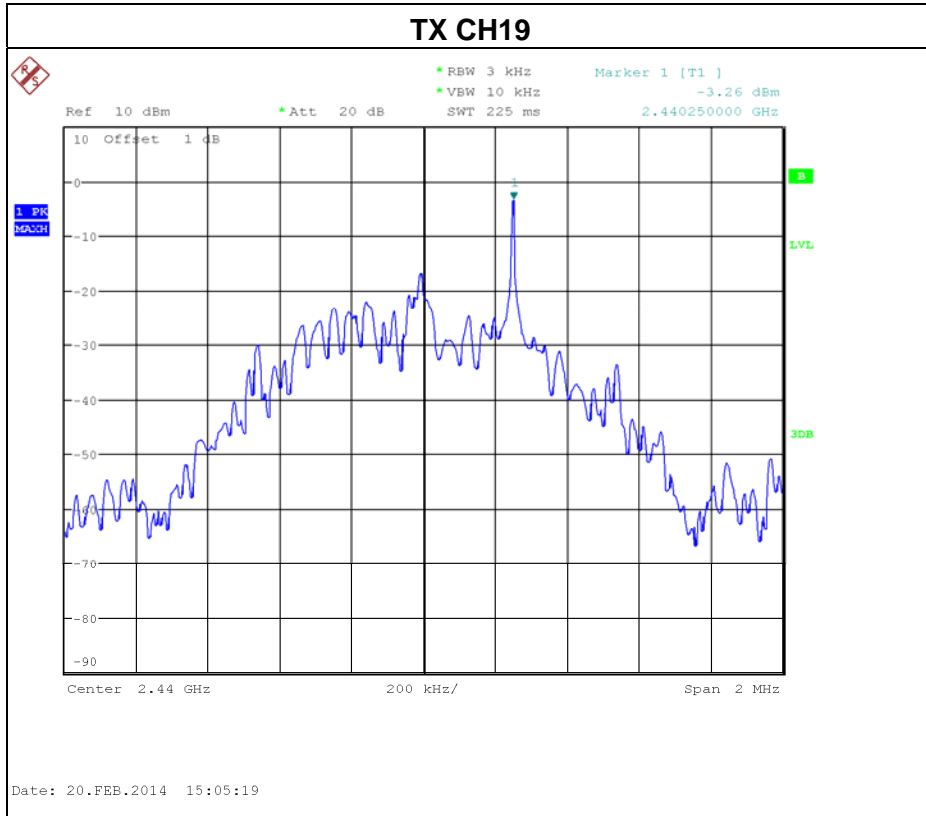



9. MEASUREMENT INSTRUMENTS LIST

Conducted Emission Measurement					
Item	Kind of Equipment	Manufacturer	Type No.	Serial No.	Calibrated until
1	LISN	EMCO	3816/2	00052765	Mar. 29, 2015
2	LISN	R&S	ENV216	101447	Mar. 29, 2015
3	Test Cable	N/A	C_17	N/A	Mar. 14, 2015
4	EMI TEST RECEIVER	R&S	ESCS30	833364/017	Mar. 29, 2015
5	50Ω Terminator	SHX	TF2-3G-A	08122902	Mar. 29, 2015

Radiated Emission Measurement					
Item	Kind of Equipment	Manufacturer	Type No.	Serial No.	Calibrated until
1	Antenna	Schwarbeck	VULB9160	9160-3232	Mar. 29, 2015
2	Amplifier	HP	8447D	2944A09673	Mar. 29, 2015
3	Receiver	AGILENT	N9038A	MY52130039	Aug. 24, 2014
4	Test Cable	N/A	C-01_CB03	N/A	Jul. 02, 2014
5	Antenna	ETS	3115	00075789	Mar. 29, 2015
6	Amplifier	Agilent	8449B	3008A02274	Mar. 29, 2015
7	Receiver	AGILENT	N9038A	MY52130039	Aug. 24, 2014
8	Test Cable	HUBER+SUHNER	C-48	N/A	Apr. 30, 2015
9	Controller	CT	SC100	N/A	N/A
10	Horn Antenna	EMCO	3115	9605-4803	Mar. 29, 2015
11	Broad-Band Horn Antenna	Schwarzbeck	BBHA 9170	9170319	Feb. 22, 2015
12	Active Loop Antenna	R&S	HFH2-Z2	830749/020	Mar. 29, 2015

6dB Bandwidth Measurement					
Item	Kind of Equipment	Manufacturer	Type No.	Serial No.	Calibrated until
1	Spectrum Analyzer	R&S	FSP 40	100185	Nov. 11, 2014



Peak Output Power Measurement					
Item	Kind of Equipment	Manufacturer	Type No.	Serial No.	Calibrated until
1	power Meter	ANRITSU	ML2495A	1128009	May. 24, 2014
2	Pulse Power Sensor	ANRITSU	MA 2411B	1027500	May. 24, 2014

Antenna Conducted Spurious Emission Measurement					
Item	Kind of Equipment	Manufacturer	Type No.	Serial No.	Calibrated until
1	Spectrum Analyzer	R&S	FSP 40	100185	Nov. 11, 2014

Power Spectral Density Measurement					
Item	Kind of Equipment	Manufacturer	Type No.	Serial No.	Calibrated until
1	Spectrum Analyzer	R&S	FSP 40	100185	Nov. 11, 2014

Remark: "N/A" denotes no model name, serial no. or calibration specified.

All calibration period of equipment list is one year.