



**Neutron Engineering Inc.**

# FCC&IC Radio Test Report

**FCC ID: VOB-P1988**

**IC: 7631A-P1988**

This report concerns (check one):  Original Grant  Class II Change

**Issued Date** : Mar. 19, 2014  
**Project No.** : 1402C004A  
**Equipment** : Tablet  
**Model Name** : P1988  
**Applicant** : NVIDIA CORPORATION  
**Address** : 2701 SAN TOMAS EXPRESSWAY,  
SANTA CLARA, CALIFORNIA 95050,  
UNITED STATES OF AMERICA

**Tested by:** Neutron Engineering Inc. EMC Laboratory

**Date of Receipt:** Feb. 10, 2014

**Date of Test:** Feb. 10, 2014 ~ Mar. 18, 2014

Testing Engineer : David Mao  
(David Mao)

Technical Manager : Leo Hung  
(Leo Hung)

Authorized Signatory : Steven Lu  
(Steven Lu)

## Neutron Engineering Inc.

No.3, Jinshagang 1st Road, ShiXia,  
Dalang Town, Dong Guan, China.

TEL: 0769-8318-3000

FAX: 0769-8319-6000



### **Declaration**

**Neutron** represents to the client that testing is done in accordance with standard procedures as applicable and that test instruments used has been calibrated with the standards traceable to National Measurement Laboratory (**NML**) of **R.O.C.**, or National Institute of Standards and Technology (**NIST**) of **U.S.A.**

**Neutron's** reports apply only to the specific samples tested under conditions. It is manufacture's responsibility to ensure that additional production units of this model are manufactured with the identical electrical and mechanical components. **Neutron** shall have no liability for any declarations, inferences or generalizations drawn by the client or others from **Neutron** issued reports.

**Neutron's** reports must not be used by the client to claim product endorsement by the authorities or any agency of the Government.

This report is the confidential property of the client. As a mutual protection to the clients, the public and **Neutron-self**, extracts from the test report shall not be reproduced except in full with **Neutron's** authorized written approval.

**Neutron's** laboratory quality assurance procedures are in compliance with the **ISO Guide 17025** requirements, and accredited by the conformity assessment authorities listed in this test report.

### **Limitation**

For the use of the authority's logo is limited unless the Test Standard(s)/Scope(s)/Item(s) mentioned in this test report is (are) included in the conformity assessment authorities acceptance respective.



<b>Table of Contents</b>	<b>Page</b>
<b>REPORT ISSUED HISTORY</b>	<b>5</b>
<b>1 . CERTIFICATION</b>	<b>6</b>
<b>2 . SUMMARY OF TEST RESULTS</b>	<b>7</b>
2.1 TEST FACILITY	8
2.2 MEASUREMENT UNCERTAINTY	8
<b>3 . GENERAL INFORMATION</b>	<b>9</b>
3.1 GENERAL DESCRIPTION OF EUT	9
3.2 DESCRIPTION OF TEST MODES	10
3.3 BLOCK DIGRAM SHOWING THE CONFIGURATION OF SYSTEM TESTED	11
3.4 DESCRIPTION OF SUPPORT UNITS	11
<b>4 . TEST RESULT</b>	<b>12</b>
4.1 RADIATED RF OUTPUT POWER MEASUREMENT	12
4.1.1 LIMIT	12
4.1.2 MEASURING INSTRUMENTS AND SETTING	12
4.1.3 TEST PROCEDURE	12
4.1.4 TEST SETUP LAYOUT	13
4.1.5 TEST DEVIATION	13
4.1.6 EUT OPERATION DURING TEST	13
4.1.7 EUT TEST CONDITIONS	13
4.1.8 TEST RESULT OF RADIATED RF OUTPUT POWER	14
4.2 99% OCCUPIED BANDWIDTH MEASUREMENT	15
4.2.1 LIMIT	15
4.2.2 MEASURING INSTRUMENTS AND SETTING	15
4.2.3 TEST PROCEDURE	15
4.2.4 TEST SETUP LAYOUT	15
4.2.5 TEST DEVIATION	15
4.2.6 EUT OPERATION DURING TEST	15
4.2.7 EUT TEST CONDITIONS	15
4.2.8 TEST RESULT OF 99% OCCUPIED BANDWIDTH	16
4.3 SPURIOUS EMISSIONS AT ANTENNA TERMINALS MEASUREMENT	20
4.3.1 LIMIT	20
4.3.2 MEASURING INSTRUMENTS AND SETTING	20
4.3.3 TEST PROCEDURES	20
4.3.4 TEST SETUP LAYOUT	20
4.3.5 TEST DEVIATION	20
4.3.6 EUT OPERATION DURING TEST	20
4.3.7 EUT TEST CONDITIONS	21



Table of Contents	Page
4.3.8 TEST RESULT OF SPURIOUS EMISSIONS AT ANTENNA TERMINALS	22
4.4 SPURIOUS RADIATED EMISSIONS MEASUREMENT	26
4.4.1 LIMIT	26
4.4.2 MEASURING INSTRUMENTS AND SETTING	26
4.4.3 TEST PROCEDURES	26
4.4.4 TEST SETUP LAYOUT	27
4.4.5 TEST DEVIATION	27
4.4.6 EUT OPERATION DURING TEST	27
4.4.7 EUT TEST CONDITIONS	27
4.4.8 RESULTS OF TRANSMITTER SPURIOUS EMISSIONS BELOW 1GHZ	28
4.4.9 RESULTS OF TRANSMITTER SPURIOUS EMISSIONS ABOVE 1GHZ	41
4.5 BAND EDGE MEASUREMENT	54
4.5.1 LIMIT	54
4.5.2 MEASURING INSTRUMENTS AND SETTING	54
4.5.3 TEST PROCEDURES	54
4.5.4 TEST SETUP LAYOUT	54
4.5.5 TEST DEVIATION	54
4.5.6 EUT OPERATION DURING TEST	54
4.5.7 EUT TEST CONDITIONS	54
4.5.8 TEST RESULTS OF BAND EDGE	55
4.6 FREQUENCY STABILITY MEASUREMENT	57
4.6.1 LIMIT	57
4.6.2 MEASURING INSTRUMENTS AND SETTING	57
4.6.3 TEST PROCEDURES	57
4.6.4 TEST SETUP LAYOUT	57
4.6.5 TEST DEVIATION	57
4.6.6 EUT OPERATION DURING TEST	57
4.6.7 EUT TEST CONDITIONS	58
4.6.8 RESULTS OF FREQUENCY STABILITY	59
4.7 CONDUCTED EMISSION MEASUREMENT	61
4.7.1 POWER LINE CONDUCTED EMISSION LIMITS	61
4.7.2 TEST PROCEDURE	62
4.7.3 DEVIATION FROM TEST STANDARD	62
4.7.4 TEST SETUP	62
4.7.5 EUT OPERATING CONDITIONS	62
4.7.6 EUT TEST CONDITIONS	62
4.7.7 TEST RESULTS	63
5. LIST OF MEASUREMENT EQUIPMENTS	66
6. EUT TEST PHOTO	68



**REPORT ISSUED HISTORY**

Issued No.	Description	Issued Date
NEI-FICP-4-1402C004A	Original Issue.	Mar. 19, 2014



## 1. CERTIFICATION

Equipment : Tablet  
Brand Name : NVIDIA  
Model Name : P1988  
Applicant : NVIDIA CORPORATION  
Manufacturer : NVIDIA CORPORATION  
Address : 2701 SAN TOMAS EXPRESSWAY, SANTA CLARA, CALIFORNIA 95050,  
UNITED STATES OF AMERICA  
Factory : HONGFUJIN PRECISION ELECTRONICS (TIANJIN) CO., LTD  
Address : A01, NO.36, North Street, West Zone, Economic & Technological Development  
Area, Tianjin  
Date of Test : Feb. 10, 2014 ~ Mar. 18, 2014  
Test Item : ENGINEERING SAMPLE  
Standard(s) : 47 CFR FCC Part 22 Subpart H & ANSI/ C63.4 : 2009  
47 CFR FCC Part 2 & ANSI/TIA-603-C-2004  
RSS-132 Issue 3 January 2013

The above equipment has been tested and found compliance with the requirement of the relative standards by Neutron Engineering Inc. EMC Laboratory.

The test data, data evaluation, and equipment configuration contained in our test report (Ref No. NEI-FICP-4-1402C004A) were obtained utilizing the test procedures, test instruments, test sites that has been accredited by the Authority of TAF according to the ISO-17025 quality assessment standard and technical standard(s).

**Test result included in this report is only for the GSM 850MHz approval part of the product.**



**2. SUMMARY OF TEST RESULTS**

Test procedures according to the technical standard(s):

FCC Part 22 Subpart H & Part 2/ RSS-132 Issue 3				
Standard(s) Section		Test Item	Judgment	Remark
FCC	IC			
2.1047(d)	5.2	Modulation Characteristics	PASS	
2.1046 22.913(a)	5.4	Radiated RF Output	PASS	
2.1049(h) 22.917(a)	-	99% Occupied Bandwidth	PASS	
2.1051 22.917(a)	5.5	Spurious Emissions at Antenna Terminal	PASS	
2.1053 22.917(a)	5.5	Spurious Radiated Emissions	PASS	
22.917(a)	5.5	Band Edge Emissions	PASS	
2.1055 22.355	5.3	Frequency Stability	PASS	
15.207	5.5	Conducted Emission	PASS	

**NOTE:**

(1) "N/A" denotes test is not applicable in this Test Report



**2.1 TEST FACILITY**

The test facilities used to collect the test data in this report is **DG-C02/DG-CB02** at the location of No.3,Jinshagang 1st Road, ShiXia, Dalang Town, Dong Guan, China.523792

Neutron's test firm number for FCC: 319330

Neutron's test firm number for IC: 4428B-1

**2.2 MEASUREMENT UNCERTAINTY**

Where relevant, the following measurement uncertainty levels have been estimated for tests performed on the EUT as specified in CISPR 16-4-2:

The reported uncertainty of measurement  $y \pm U$ , where expanded uncertainty  $U$  is based on a standard uncertainty multiplied by a coverage factor of  $k=2$ , providing a level of confidence of approximately **95 %**.

A. Conducted Measurement :

Test Site	Method	Measurement Frequency Range	U , (dB)	NOTE
DG-C02	CISPR	150 KHz ~ 30MHz	1.94	

B. Radiated Measurement :

Test Site	Method	Measurement Frequency Range	Ant. H / V	U , (dB)	NOTE
DG-CB02	CISPR	30MHz ~ 200MHz	V	3.82	
		30MHz ~ 200MHz	H	3.60	
		200MHz ~ 1,000MHz	V	3.86	
		200MHz ~ 1,000MHz	H	3.94	





**3. GENERAL INFORMATION**

**3.1 GENERAL DESCRIPTION OF EUT**

Equipment	Tablet		
Brand Name	NVIDIA		
Model Name	P1988		
Model Difference	N/A		
Product Description	Operation Frequency:	TX:824.2MHz~848.8MHz RX:869.2MHz~893.8MHz	
	Modulation Type:	GMSK;8-PSK	
	ERP Output Power	24.30dBm	
Channel List	Please refer to the Note 2.		
Power Source	#1 DC voltage supplied from AC adapter. 1) Brand/ Model: NVIDIA / P2551 2) Brand/ Model: Chicony / W12-010N3A #2 Supplied from lithium-ion battery. 1) Brand/ Model: YOKU/ 32102102 #3 Supplied from USB charging.		
Power Rating	#1 AC adapter 1) I/P: AC 100-240V~, 50-60Hz, 0.3A O/P: DC 5.2V, 2.1A 2) I/P: AC 100-240V~, 50/60Hz, 0.3A O/P: DC 5.35V, 2A #2 Lithium-ion battery 1) DC 3.7V 4100mAh #3 USB charging 1) DC 5V 2A		
Connecting I/O Port(s)	Please refer to the User's Manual		

Note:

- For a more detailed features description, please refer to the manufacturer's specifications or the User's Manual.
- 

Band	Channel	Frequency	
		(MHz)	
824.2MHz~848.8MHz	128	Low	824.2
	190	Mid	836.6
	251	High	848.8

3.

Table for Filed Antenna @GSM850

Ant.	Manufacture	Model Name	Antenna Type	Connector	Gain (dBi)
1	SPEED	G-KW-0001	Monopole	N/A	0.52



**3.2 DESCRIPTION OF TEST MODES**

To investigate the maximum EMI emission characteristics generated from EUT, the test system was pre-scanning tested based on the consideration of following EUT operation mode or test configuration mode which possibly have effect on EMI emission level. Each of these EUT operation mode(s) or test configuration mode(s) mentioned above was evaluated respectively.

Test Items	Worst TX Mode	Channel
Radiated RF Output	GSM	128/190/251
Spurious Radiated Emissions	GSM	128/190/251
Band Edge	GSM	128/251
Frequency Stability	GSM	128
99% Occupied Bandwidth	GSM	128/190/251
Spurious Emissions at Antenna Terminal	GSM	128/190/251

For Conducted Emission	
Final Test Mode	Description
Mode 1	TX Mode

Note:

- (1) The measurements are performed at the highest, middle, lowest available channels.
- (2) The EUT is considered a portable unit; it was pre-tested on the positioned of each 3 axis. The worst case was found positioned on X-plane. Therefore only the test data of this X-plane was used for radiated emission measurement test.



**3.3 BLOCK DIGRAM SHOWING THE CONFIGURATION OF SYSTEM TESTED**

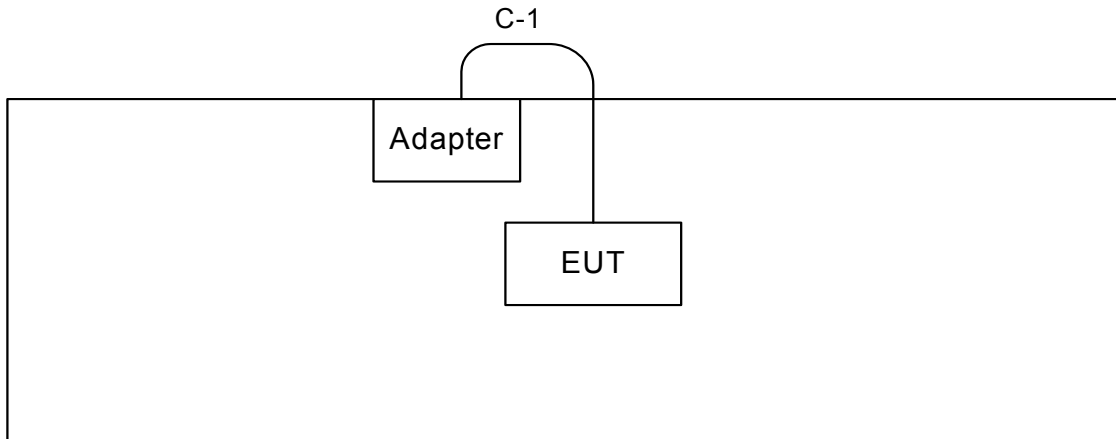

**3.4 DESCRIPTION OF SUPPORT UNITS**

The EUT has been tested as an independent unit together with other necessary accessories or support units. The following support units or accessories were used to form a representative test configuration during the tests.

Item	Equipment	Mfr/Brand	Model/Type No.	FCC ID/IC	Series No.	Note
-	-	-	-	-	-	

Item	Shielded Type	Ferrite Core	Length	Note
C-1	YES	NO	0.8m	USB Cable



#### **4. TEST RESULT**

##### **4.1 RADIATED RF OUTPUT POWER MEASUREMENT**

###### **4.1.1 LIMIT**

The Radiated Peak Output Power shall be according to the specific rule Part 22.913(a)&RSS-132 section 5.4 that “Mobile/Portable station are limited to 7 watts e.r.p.” and 22.913(a)&RSS-132 section 5.4 specified that “Peak transmit power must be measure over any interval of continuous transmission using instrumentation calibration in terms of rms-equivalent voltage.

###### **4.1.2 MEASURING INSTRUMENTS AND SETTING**

Please refer to section 5 in this report. The following table is the setting of the Spectrum Analyzer.

<b>Spectrum Parameters</b>	<b>Setting</b>
Attenuation	Auto
Center Frequency	Low / middle / high channels
Span Frequency	10MHz
RB / VB	3MHz / 3MHz for Peak

###### **4.1.3 TEST PROCEDURE**

1. The EUT was set up for the maximum peak power with GSM/EGPRS link data modulation. The power was measured with R&S Spectrum Analyzer. All measurements were done at 3 channels, 128, 190 and 251 (low, middle and high operational frequency range).
2. The conducted peak output power used the power splitter via EUT RF power connector between simulation base station and spectrum analyzer. The path loss included the splitter loss, cable loss and 20dB pad loss. The spectrum set RB/VB 3MHz, then read peak power value and record to the test. (All transmitted path loss shall be considered in the test report data)
3. E.I.R.P peak power measurement. In the fully anechoic chamber, EUT placed on the 1.5m height of Turn Table, rotated the table around 360 degrees to search the maximum radiation power and receiver antenna shall be rotated vertical and horizontal polarization to find the maximum polar radiated power. The “Read Value” is the spectrum reading the maximum power value.
4. The substitution horn antenna is substituted for EUT at the same position, and signal generator export the CW signal to the calibration antenna. Rotated the Turn Table to find the maximum radiation power. “Raw” is the spectrum reading value, “SG” is signal generator export power, “TX Gain” is calibration antenna isotropic gain value, “TX cable” is the transmitted cable loss between the calibration antenna and signal generator. The “Factor” means that the transmission path loss is equal to “SG” - “TX cable” + “TX Gain” – “Raw”.
5. Actually the real E.I.R.P peak power is equal to “Read Value” + “Factor”
6. E.R.P power can be calculated form E.I.R.P power by subtracting the gain of Integral, E.R.P power=E.I.P.R power-2.14dBi.

**4.1.4 TEST SETUP LAYOUT  
ERP Power Measurement**

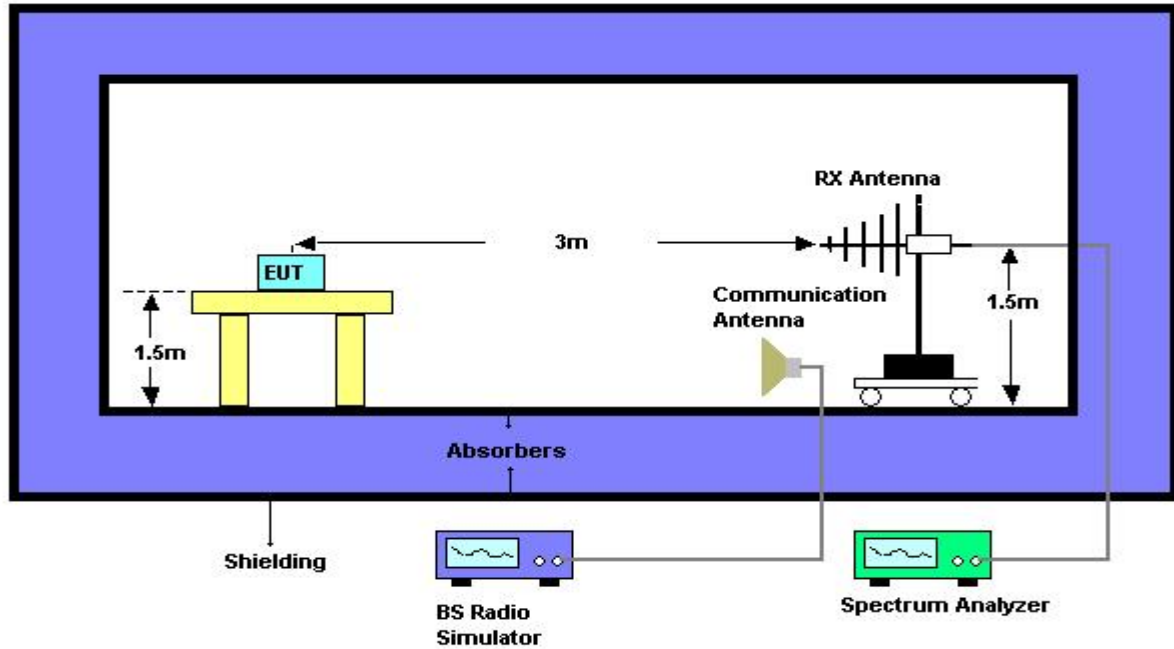

**4.1.5 TEST DEVIATION**

There is no deviation with the original standard.

**4.1.6 EUT OPERATION DURING TEST**

The BS simulator was used to set the TX channel and power level and modulate the TX signal.

**4.1.7 EUT TEST CONDITIONS**

Temperature: 25°C  
Relative Humidity: 55%  
Test Voltage: 3.7V



**4.1.8 TEST RESULT OF RADIATED RF OUTPUT POWER**

Test Mode :	TX CH 128/190/251
-------------	-------------------

**GSM 850**

GSM 850		Radiated Power(dBm)			Max. Limit (dBm)	Result
		Channel 128	Channel 190	Channel 251		
GSM	V	15.83	17.03	16.78	38.45	Complies
	H	23.80	23.79	23.84	38.45	Complies
EGPRS	V	17.74	17.53	16.78	38.45	Complies
	H	24.30	23.79	23.34	38.45	Complies

**REMARKS:**

1. Radiated Output Power(dBm)=Raw Value(dBm) + Correction Factor(dB) +Ant Gain(dBi)
2. Correction Factor(dB) = Power Splitter Loss(dB) + Cable Loss(dB)
3. The EUT does employ a power control function by which the output power is controlled from +30dBm to +19dBm (nominal) by 2dB steps. Consequently the EUT meets the requirement of Part22.913(a)
4. The antenna gain is 0.52dBi

## 4.2 99% OCCUPIED BANDWIDTH MEASUREMENT

### 4.2.1 LIMIT

According to FCC 2.1049(h) specified that emission bandwidth is defined as the width of the signal between two points, one below the carrier center frequency and one above the carrier center frequency, outside of which all emissions are attenuated at least 26 dB below the transmitter power.

### 4.2.2 MEASURING INSTRUMENTS AND SETTING

Please refer to section 5 in this report. The following table is the setting of the Spectrum Analyzer.

Spectrum Parameters	Setting
Attenuation	Auto
Span Frequency	Encompass the entire emissions bandwidth (EBW) of the signal
RB	30 kHz
VB	100 kHz
Trace	Max Hold

### 4.2.3 TEST PROCEDURE

1. The transmitter output (antenna port) was connected to the spectrum analyzer.
2. Used measurement function of spectrum to measure the 99% occupied bandwidth..

### 4.2.4 TEST SETUP LAYOUT

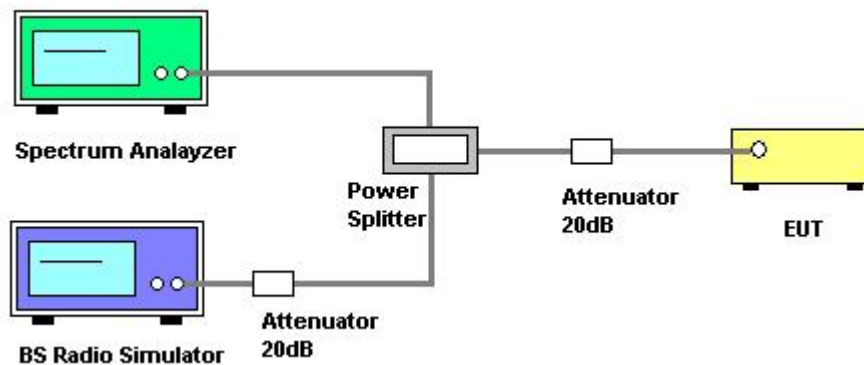

### 4.2.5 TEST DEVIATION

There is no deviation with the original standard.

### 4.2.6 EUT OPERATION DURING TEST

The BS simulator was used to set the TX channel and power level and modulate the TX signal.

### 4.2.7 EUT TEST CONDITIONS

Temperature: 25°C  
Relative Humidity: 55%  
Test Voltage: 3.7V



**4.2.8 TEST RESULT OF 99% OCCUPIED BANDWIDTH**

Test Mode : TX Mode Configuration GSM				
Channel	Frequency	99% OBW (kHz)	-26dBc Bandwidth	Result
128	824.20 MHz	244.00	328.00	Complies
190	836.60 MHz	244.00	326.00	Complies
251	848.80 MHz	244.00	326.00	Complies

**99% Occupied Bandwidth channel 128**

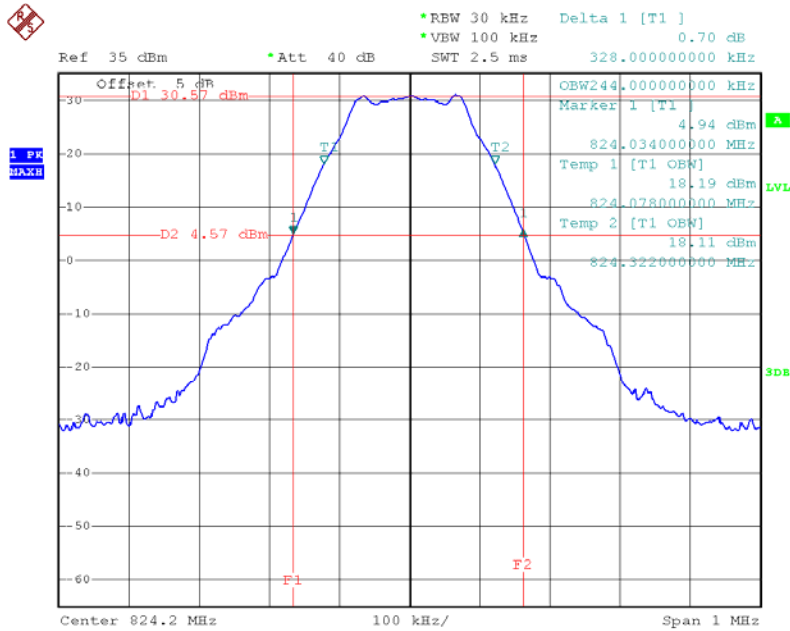

Date: 4.MAR.2014 04:13:07





99% Occupied Bandwidth channel 190

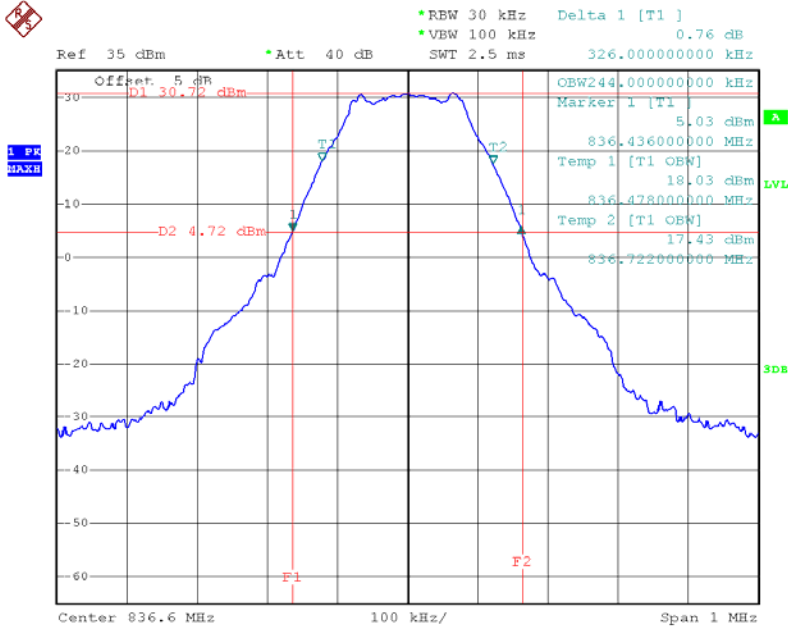

Date: 4.MAR.2014 04:14:40

99% Occupied Bandwidth channel 251

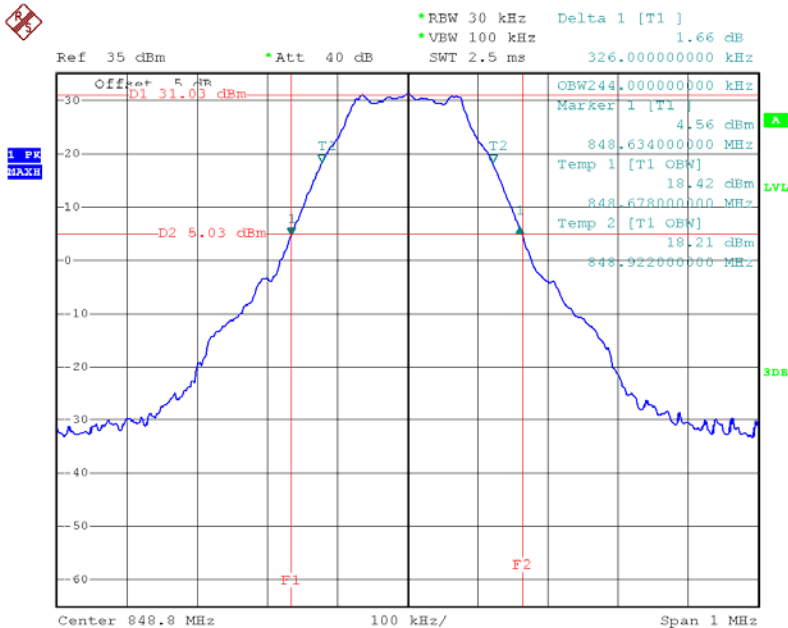

Date: 4.MAR.2014 04:16:07



Test Mode : TX Mode Configuration EGPRS				
Channel	Frequency	99% OBW (kHz)	-26dBc Bandwidth	Result
128	824.20 MHz	244.00	264.00	<b>Complies</b>
190	836.60 MHz	246.00	266.00	<b>Complies</b>
251	848.80 MHz	244.00	260.00	<b>Complies</b>

**99% Occupied Bandwidth channel 128**

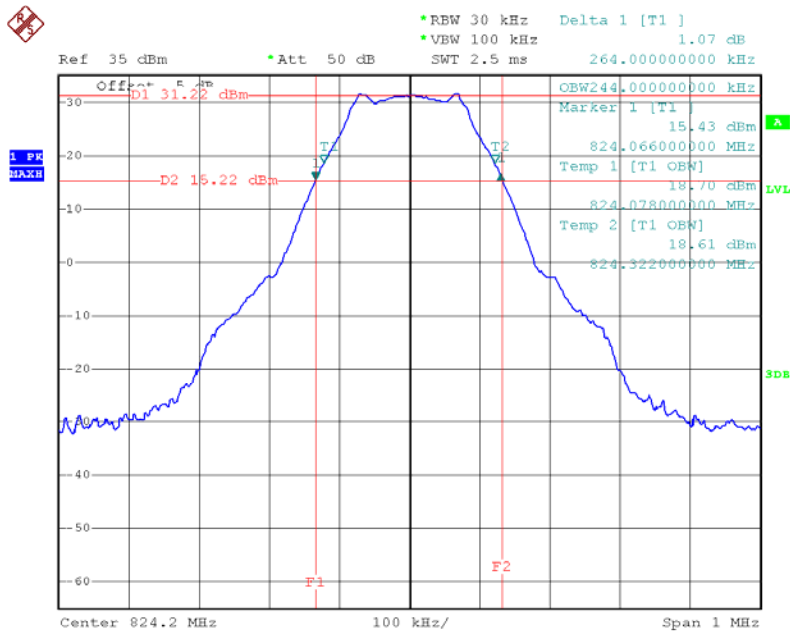

Date: 20.MAR.2014 20:08:36



99% Occupied Bandwidth channel 190

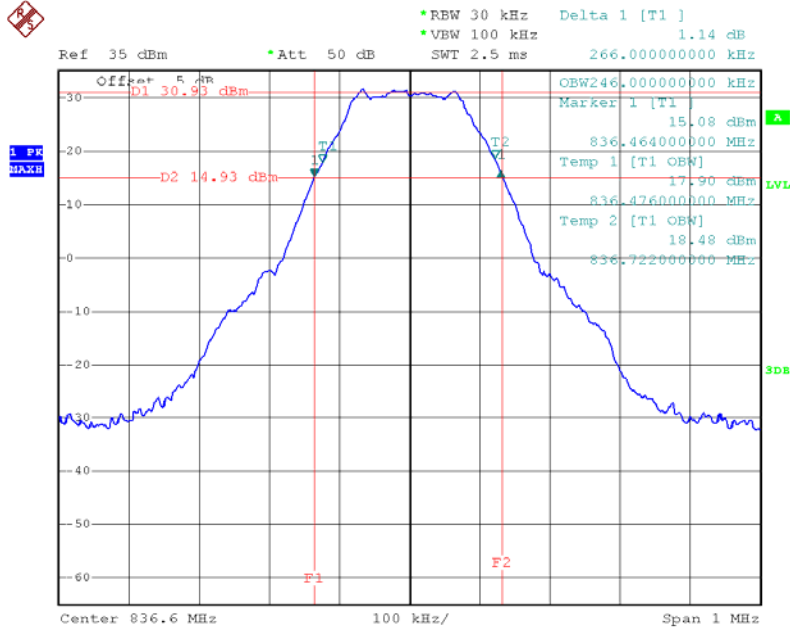

Date: 20.MAR.2014 20:10:19

99% Occupied Bandwidth channel 251

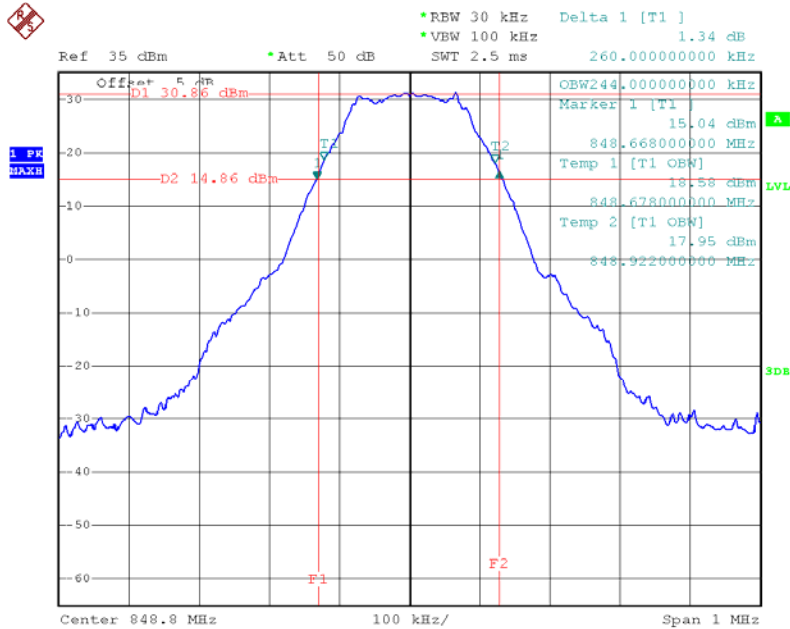

Date: 20.MAR.2014 20:11:35

### 4.3 SPURIOUS EMISSIONS AT ANTENNA TERMINALS MEASUREMENT

#### 4.3.1 LIMIT

In the FCC 22.917(a)&RSS-132 section 5.5, on any frequency outside a licensee’s frequency block within GSM spectrum, the power of any emission shall be attenuated below the transmitter power (P) by at least  $43 + 10 \log (P)$  dB. The limit translates in the relevant power range (2 to 0.003W). At 2W(Power Control Level 5) the specified minimum attenuation becomes 43dB and the limit of emission equal to  $-13\text{dBm}$

#### 4.3.2 MEASURING INSTRUMENTS AND SETTING

Please refer to section 5 in this report. The following table is the setting of the Spectrum Analyzer.

Spectrum Parameters	Setting
Attenuation	Auto
Start Frequency	30MHz
Stop Frequency	10th carrier harmonic
RB / VB	1 MHz / 1MHz for Peak

#### 4.3.3 TEST PROCEDURES

1. The EUT was set up for the maximum peak power with **GSM/EGPRS** link data modulation. The power was measured with R&S Spectrum Analyzer. All measurements were done at 3 channels, 128, 190 and 251(low, middle and high operational frequency range.)
2. The conducted spurious emission used the power splitter via EUT RF power connector between simulation base station and spectrum analyzer. This splitter loss and cable loss are the worst loss 4dB in the transmitted path track.
3. When the spectrum scanned from 30MHz to 3GHz, it shall be connected to the band reject filter attenuated the carried frequency. The spectrum set RB/VB 1MHz.
4. When the spectrum scanned from 3GHz to 10GHz, it shall be connected to the high pass filter attenuated the carried frequency. The spectrum set RB/VB 1MHz.

#### 4.3.4 TEST SETUP LAYOUT

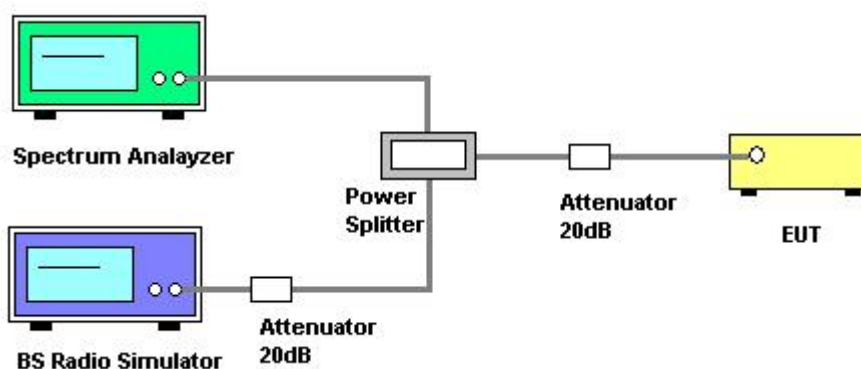

#### 4.3.5 TEST DEVIATION

There is no deviation with the original standard.

#### 4.3.6 EUT OPERATION DURING TEST

The BS simulator was used to set the TX channel and power level and modulate the TX signal.



**4.3.7 EUT TEST CONDITIONS**

Temperature: 25°C

Relative Humidity: 55%

Test Voltage: 3.7V



### 4.3.8 TEST RESULT OF SPURIOUS EMISSIONS AT ANTENNA TERMINALS

#### Conducted Spurious of Configuration GSM channel 128

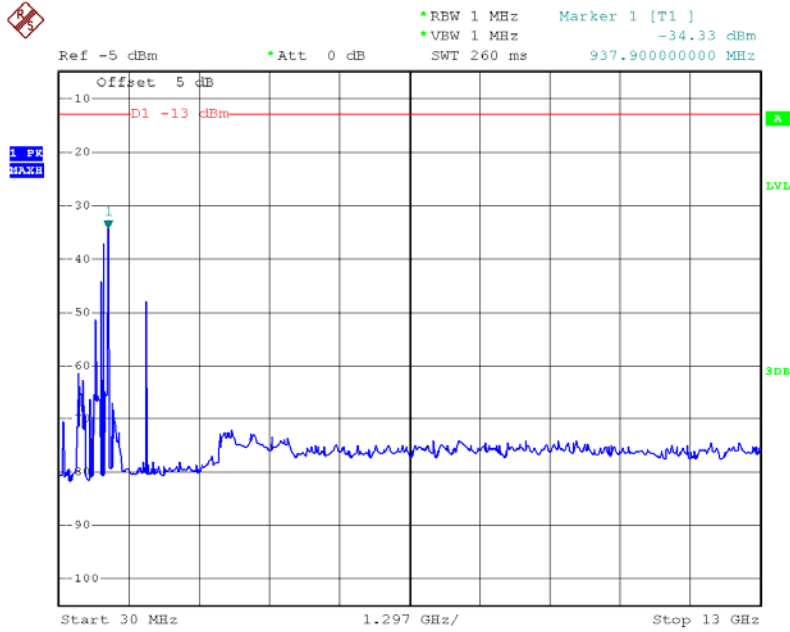

Date: 20.MAR.2014 20:22:48

#### Conducted Spurious of Configuration GSM channel 190

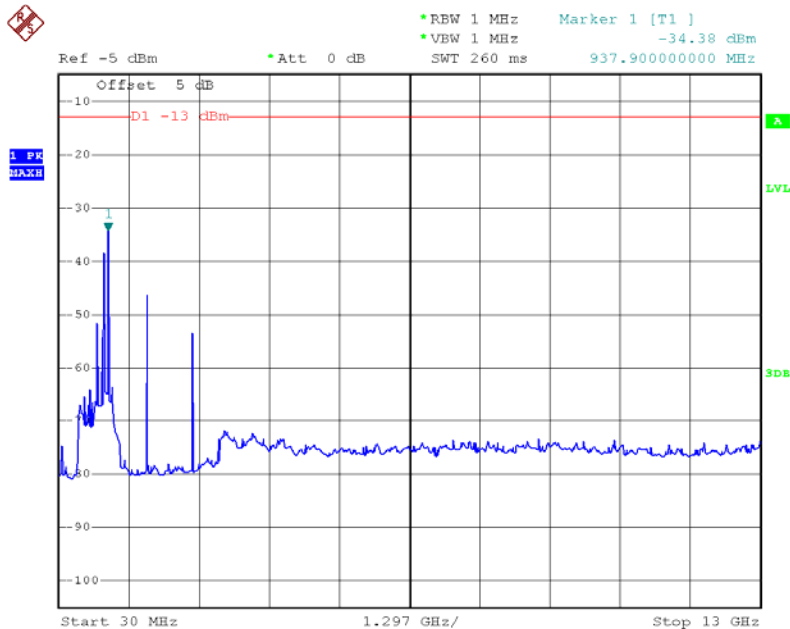

Date: 20.MAR.2014 20:23:30



### Conducted Spurious of Configuration GSM channel 251

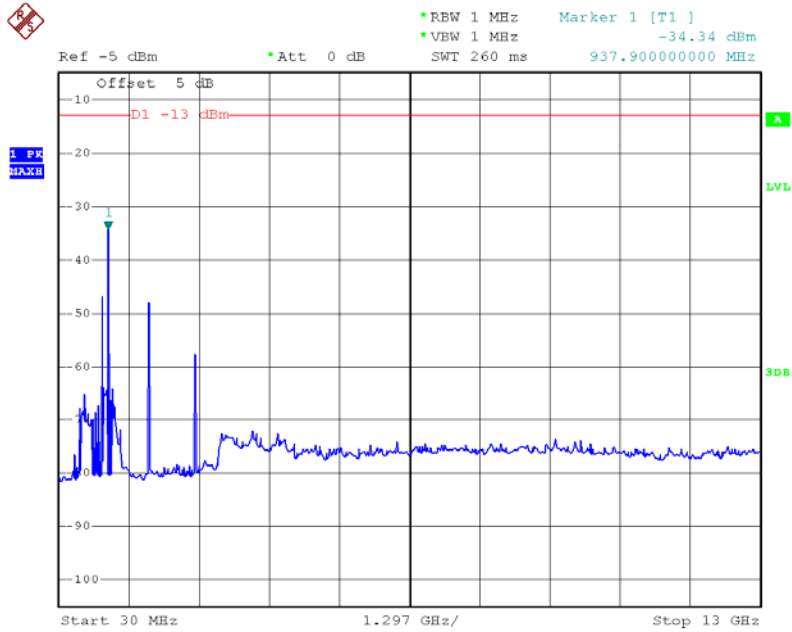

Date: 20.MAR.2014 20:24:11



### Conducted Spurious of Configuration EGPRS channel 128

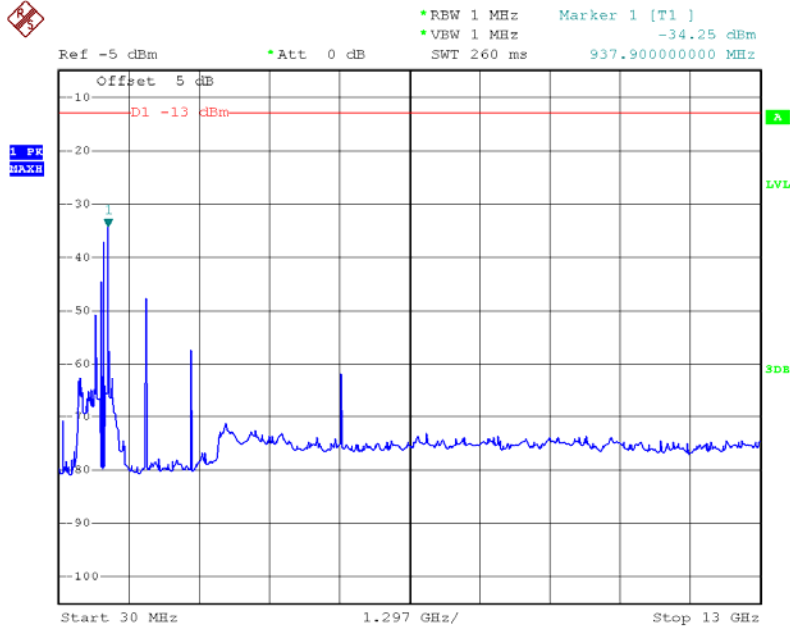

Date: 20.MAR.2014 20:22:36

### Conducted Spurious of Configuration EGPRS channel 190

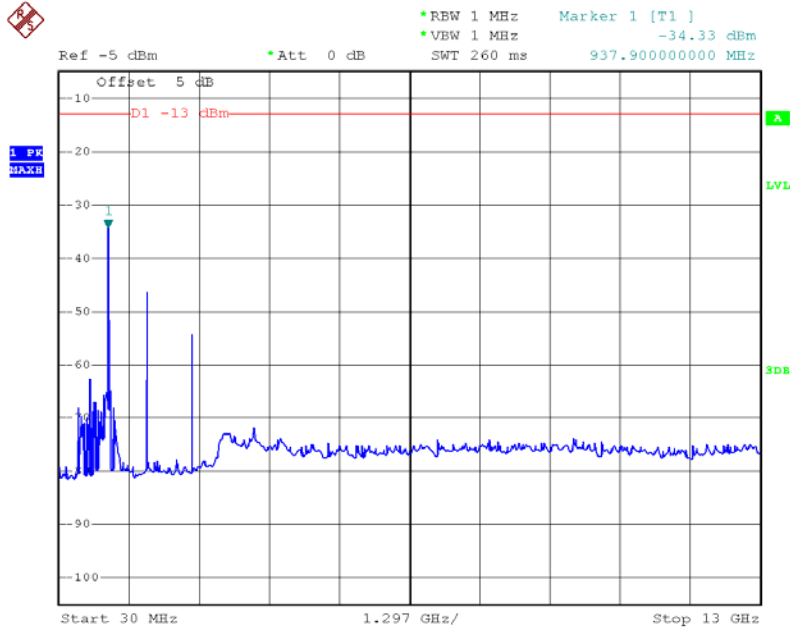

Date: 20.MAR.2014 20:23:40





### Conducted Spurious of Configuration EGPRS channel 251

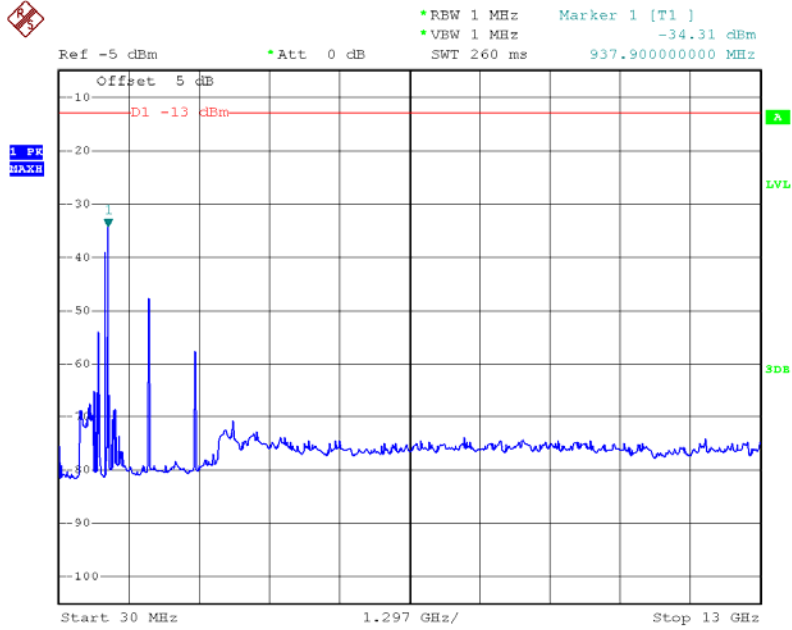

Date: 20.MAR.2014 20:24:21



#### 4.4 SPURIOUS RADIATED EMISSIONS MEASUREMENT

##### 4.4.1 LIMIT

Out of band emissions, The power of any emissions outside of the authorized operating frequency ranges must be attenuated below the transmitting power (P) by a factor of at least  $43 + 10 \log(P)$  dB. In the 1 MHz bands immediately outside the frequency block. The spurious emissions of limit equal to  $-13\text{dBm}$ .

##### 4.4.2 MEASURING INSTRUMENTS AND SETTING

Please refer to section 5 in this report. The following table is the setting of the Spectrum Analyzer.

Spectrum Parameters	Setting
Attenuation	Auto
Start Frequency	30 MHz
Stop Frequency	10th carrier harmonic
Detector	Positive Peak
Span	100 MHz
Sweep Time	1s
RB / VB	1 MHz / 1MHz
Attenuation	Positive Peak

##### 4.4.3 TEST PROCEDURES

1. The EUT was placed on the top of the turntable in fully anechoic chamber.
2. The test shall be made in the transmitting mode. The turntable was rotated by 360 degrees to determine the position of the highest radiation.
3. This measurement shall be repeated with the transmitter in standby mode where applicable.
4. For 30~1000MHz spurious emissions measurement, the broad band bi-log receiving antenna was placed 3 meters far away from the turntable. For 1~10th carrier harmonic measurement, the receiving Horn antenna was placed 1.5 meters far away from the turntable.
5. The broadband receiving antenna was fixed on the same height with the EUT to find each suspected emissions of both horizontal and vertical polarization. Each recorded suspected value is indicated as Read Level (Raw).
6. Replace the EUT by standard antenna and feed the RF port by signal generator.
7. Adjust the frequency of the signal generator to the suspected emission and slightly rotate the turntable to locate the position with maximum reading.
8. Adjust the power level of the signal generator to reach the same reading with Read Level (Raw).
9. The level of the spurious emission is the power level of (8) plus the gain of the standard antenna in dBi and minus the loss of the cable used between the signal generator and the standard antenna.



#### **4.4.4 TEST SETUP LAYOUT**

This test setup layout is the same as that shown in section 4.2.4.

#### **4.4.5 TEST DEVIATION**

There is no deviation with the original standard.

#### **4.4.6 EUT OPERATION DURING TEST**

The BS simulator was used to set the TX channel and power level and modulate the TX signal.

#### **4.4.7 EUT TEST CONDITIONS**

Temperature: 25°C

Relative Humidity: 55%

Test Voltage: 3.7V



#### **4.4.8 RESULTS OF TRANSMITTER SPURIOUS EMISSIONS BELOW 1GHZ**

Remark :

- (1) Reading in which marked as Peak means measurements by using is Peak Mode with Detector SPA setting in RBW=1MHz, VBW =1MHz, Swp. Time = 0.3 sec./MHz ◦
- (2) All readings are Peak unless otherwise stated QP in column of 『Note』 . Peak denotes that the Peak reading compliance with the QP Limits and then QP Mode measurement didn't perform ◦
- (3) Measuring frequency range from 30MHz to 1000MHz ◦
- (4) If the peak scan value lower limit more than 20dB, then this signal data does not show in table ◦



Test Mode : TX CH128 GSM

**Vertical**

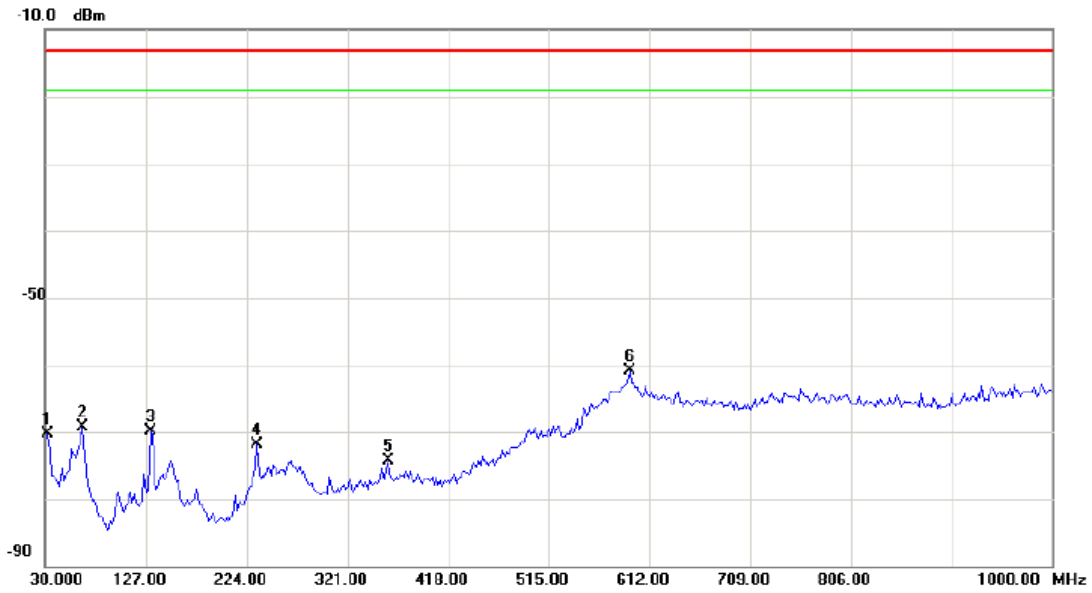

No. Mk.	Freq. MHz	Reading Level dBm	Correct Factor dB	Measurement dBm	Limit dBm	Over dB	Detector	Comment
1	31.9400	-73.70	3.32	-70.38	-13.0	-57.38	peak	
2	64.9200	-77.26	8.00	-69.26	-13.0	-56.26	peak	
3	130.8800	-69.76	-0.22	-69.98	-13.0	-56.98	peak	
4	233.7000	-73.87	1.90	-71.97	-13.0	-58.97	peak	
5	359.8000	-77.50	3.18	-74.32	-13.0	-61.32	peak	
6 *	592.6000	-76.94	15.95	-60.99	-13.0	-47.99	peak	



Test Mode : TX CH128 GSM

**Horizontal**

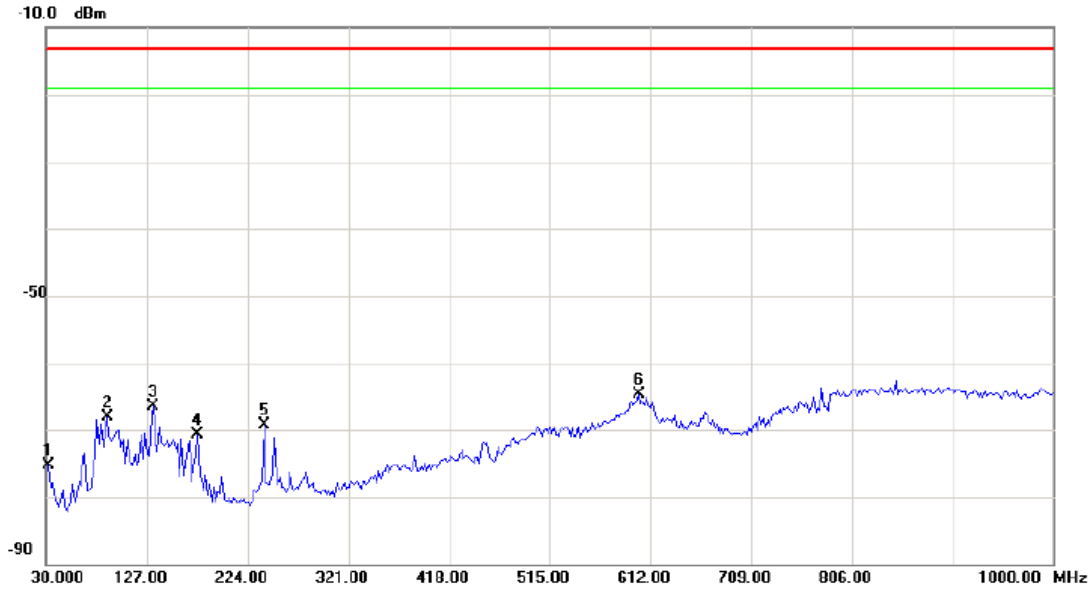

No.	Mk.	Freq. MHz	Reading Level dBm	Correct Factor dB	Measure- ment dBm	Limit dBm	Over dB	Detector	Comment
1		31.9400	-74.97	-0.23	-75.20	-13.0	-62.20	peak	
2		88.2000	-69.74	1.63	-68.11	-13.0	-55.11	peak	
3		132.8200	-70.82	4.25	-66.57	-13.0	-53.57	peak	
4		175.5000	-70.94	0.29	-70.65	-13.0	-57.65	peak	
5		239.5200	-69.78	0.56	-69.22	-13.0	-56.22	peak	
6	*	600.3600	-78.55	13.77	-64.78	-13.0	-51.78	peak	



Test Mode : TX CH190 GSM

**Vertical**

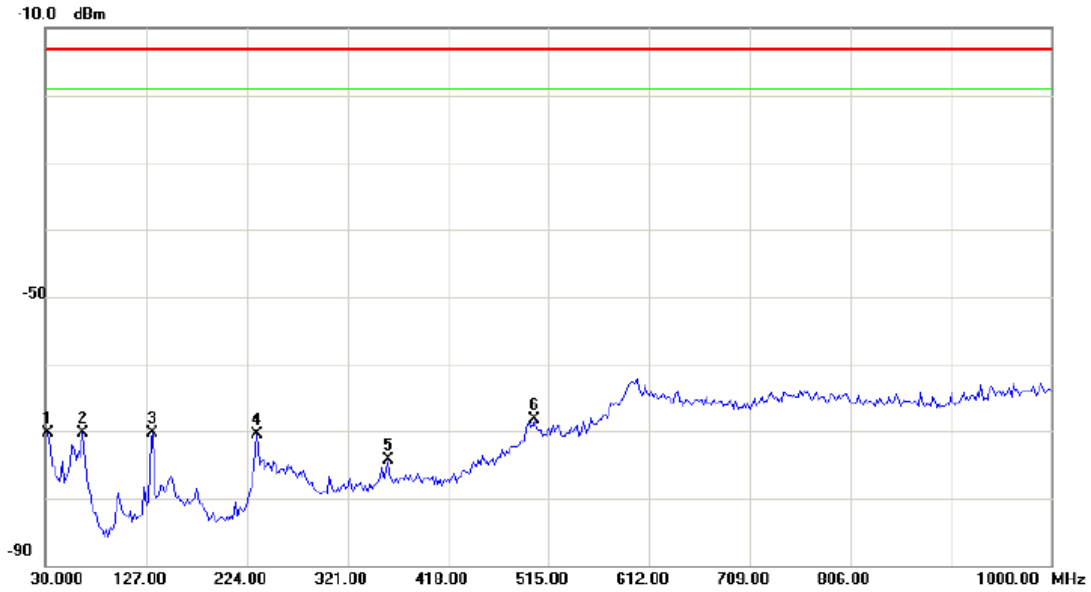

No. Mk.	Freq. MHz	Reading Level dBm	Correct Factor dB	Measurement dBm	Limit dBm	Over dB	Detector	Comment
1	31.9400	-73.70	3.32	-70.38	-13.0	-57.38	peak	
2	64.9200	-78.26	8.00	-70.26	-13.0	-57.26	peak	
3	132.8200	-70.15	-0.11	-70.26	-13.0	-57.26	peak	
4	233.7000	-72.37	1.90	-70.47	-13.0	-57.47	peak	
5	359.8000	-77.50	3.18	-74.32	-13.0	-61.32	peak	
6 *	501.4200	-78.41	10.04	-68.37	-13.0	-55.37	peak	



Test Mode : TX CH190 GSM

**Horizontal**



No.	Mk.	Freq. MHz	Reading Level dBm	Correct Factor dB	Measure- ment dBm	Limit dBm	Over dB	Detector	Comment
1		31.9400	-75.47	-0.23	-75.70	-13.0	-62.70	peak	
2		97.9000	-74.09	3.29	-70.80	-13.0	-57.80	peak	
3		132.8200	-71.82	4.25	-67.57	-13.0	-54.57	peak	
4		239.5200	-72.78	0.56	-72.22	-13.0	-59.22	peak	
5		600.3600	-78.55	13.77	-64.78	-13.0	-51.78	peak	
6	*	664.3800	-74.67	11.29	-63.38	-13.0	-50.38	peak	





Test Mode : TX CH251 GSM

**Vertical**

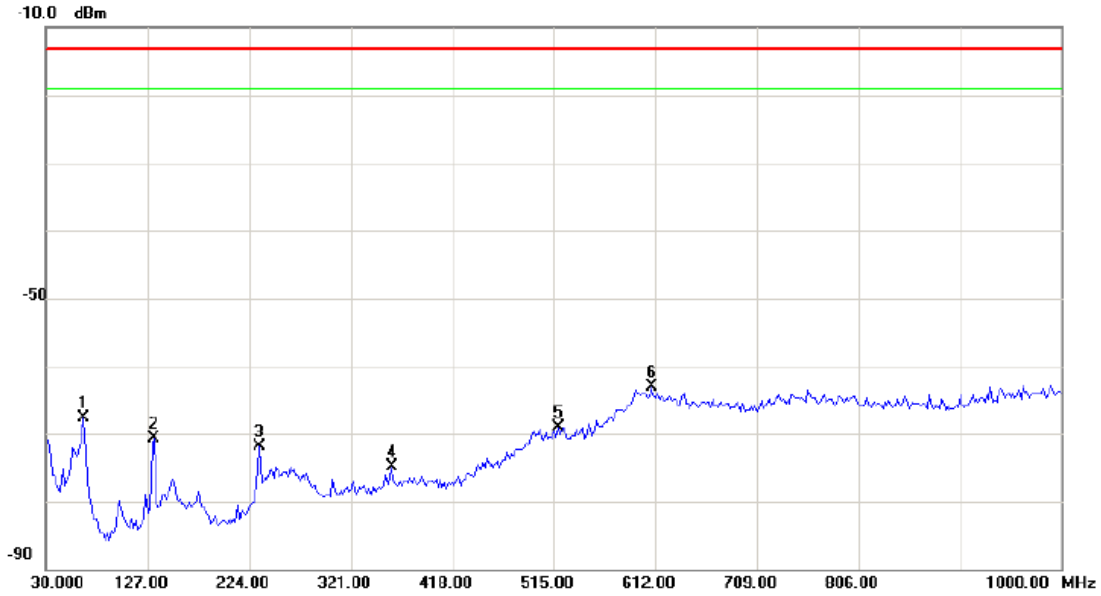

No.	Mk.	Freq. MHz	Reading Level dBm	Correct Factor dB	Measure- ment dBm	Limit dBm	Over dB	Detector	Comment
1		64.9200	-75.76	8.00	-67.76	-13.0	-54.76	peak	
2		132.8200	-70.65	-0.11	-70.76	-13.0	-57.76	peak	
3		233.7000	-73.87	1.90	-71.97	-13.0	-58.97	peak	
4		359.8000	-78.00	3.18	-74.82	-13.0	-61.82	peak	
5		518.8800	-79.41	10.39	-69.02	-13.0	-56.02	peak	
6	*	608.1200	-79.64	16.64	-63.00	-13.0	-50.00	peak	



Test Mode : TX CH251 GSM

**Horizontal**

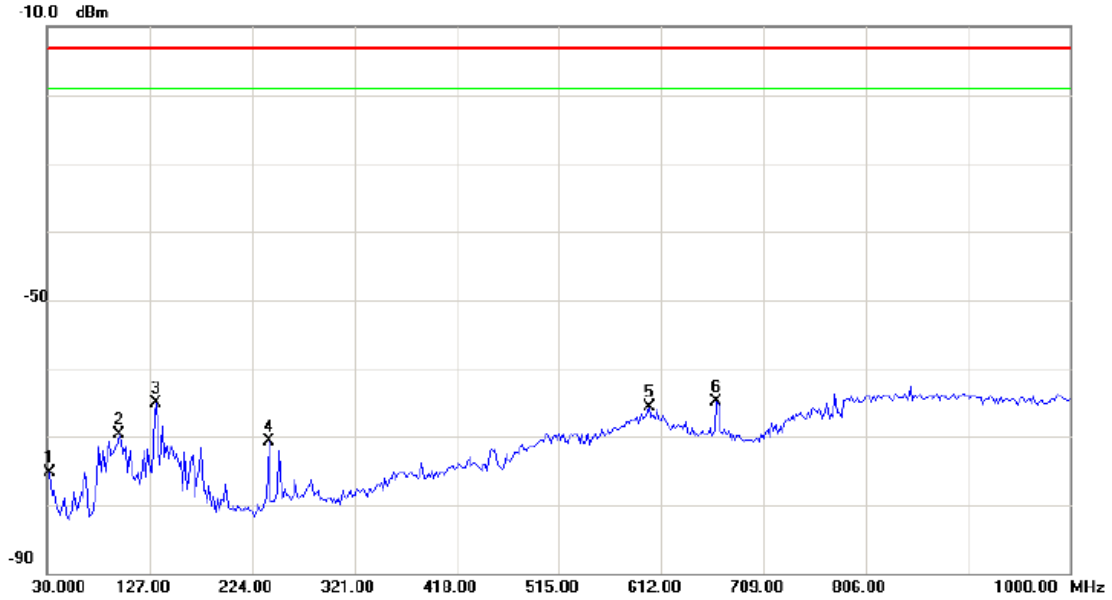

No.	Mk.	Freq. MHz	Reading Level dBm	Correct Factor dB	Measure- ment dBm	Limit dBm	Over dB	Detector	Comment
1		31.9400	-74.97	-0.23	-75.20	-13.0	-62.20	peak	
2		97.9000	-73.09	3.29	-69.80	-13.0	-56.80	peak	
3		132.8200	-69.32	4.25	-65.07	-13.0	-52.07	peak	
4		239.5200	-71.28	0.56	-70.72	-13.0	-57.72	peak	
5		600.3600	-79.55	13.77	-65.78	-13.0	-52.78	peak	
6	*	664.3800	-76.17	11.29	-64.88	-13.0	-51.88	peak	



Test Mode : TX CH128 EGPRS

**Vertical**

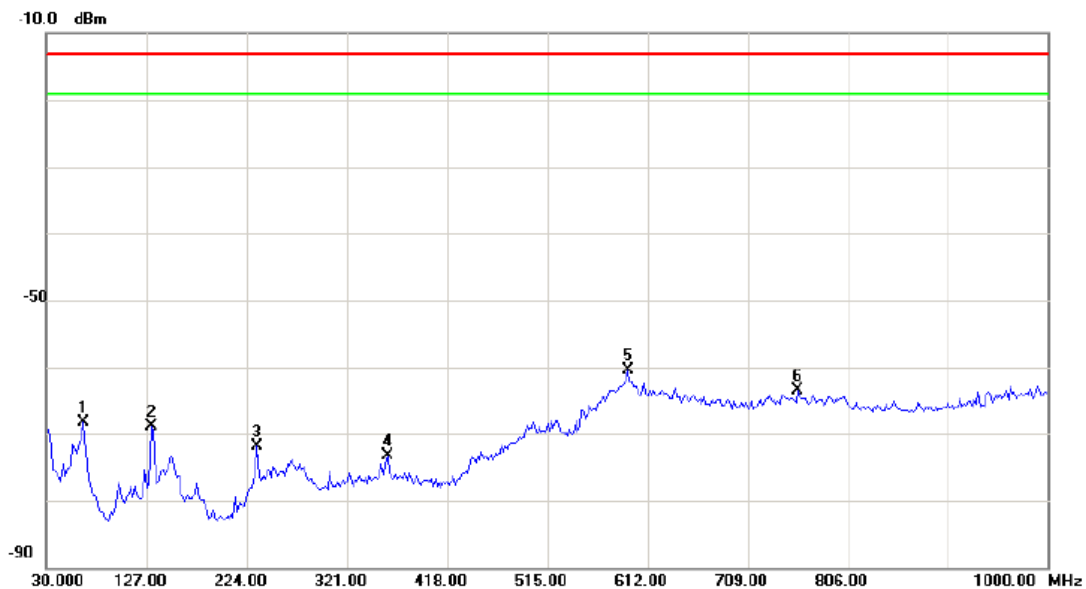

No.	Mk.	Freq. MHz	Reading Level dBm	Correct Factor dB	Measure- ment dBm	Limit dBm	Over dB	Detector	Comment
1		64.9200	-76.26	8.00	-68.26	-13.0	-55.26	peak	
2		130.8800	-68.76	-0.22	-68.98	-13.0	-55.98	peak	
3		233.7000	-73.87	1.90	-71.97	-13.0	-58.97	peak	
4		359.8000	-76.50	3.18	-73.32	-13.0	-60.32	peak	
5	*	592.6000	-76.44	15.95	-60.49	-13.0	-47.49	peak	
6		757.5000	-80.23	16.80	-63.43	-13.0	-50.43	peak	



Test Mode : TX CH128 EGPRS

Horizontal

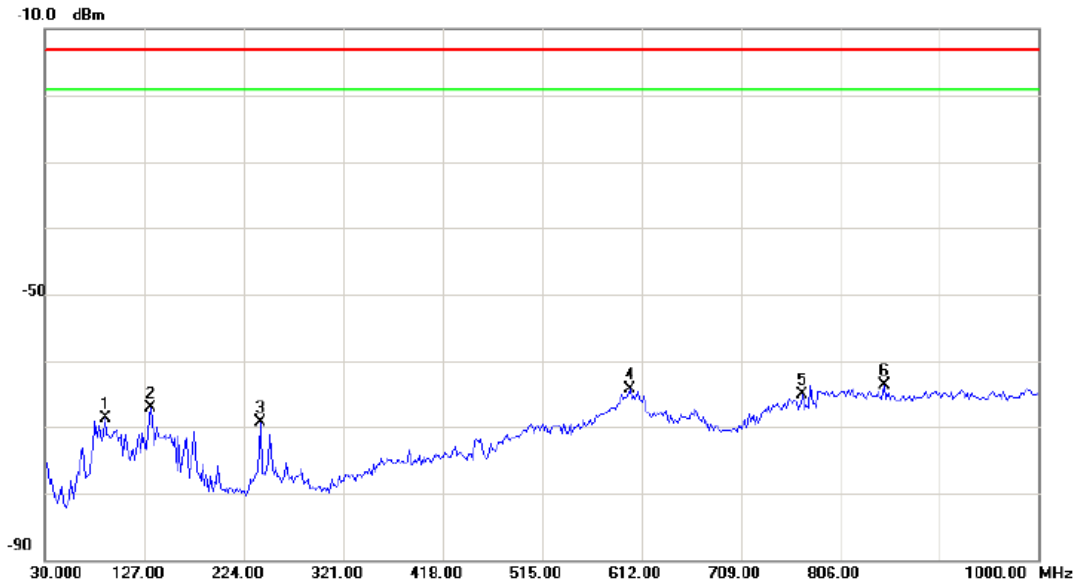

No. Mk.	Freq. MHz	Reading Level dBm	Correct Factor dB	Measurement dBm	Limit dBm	Over dB	Detector	Comment
1	88.2000	-70.24	1.63	-68.61	-13.0	-55.61	peak	
2	132.8200	-71.32	4.25	-67.07	-13.0	-54.07	peak	
3	239.5200	-69.78	0.56	-69.22	-13.0	-56.22	peak	
4	600.3600	-78.05	13.77	-64.28	-13.0	-51.28	peak	
5	769.1400	-79.73	14.54	-65.19	-13.0	-52.19	peak	
6 *	848.6800	-79.18	15.47	-63.71	-13.0	-50.71	peak	



Test Mode : TX CH190 EGPRS

Vertical

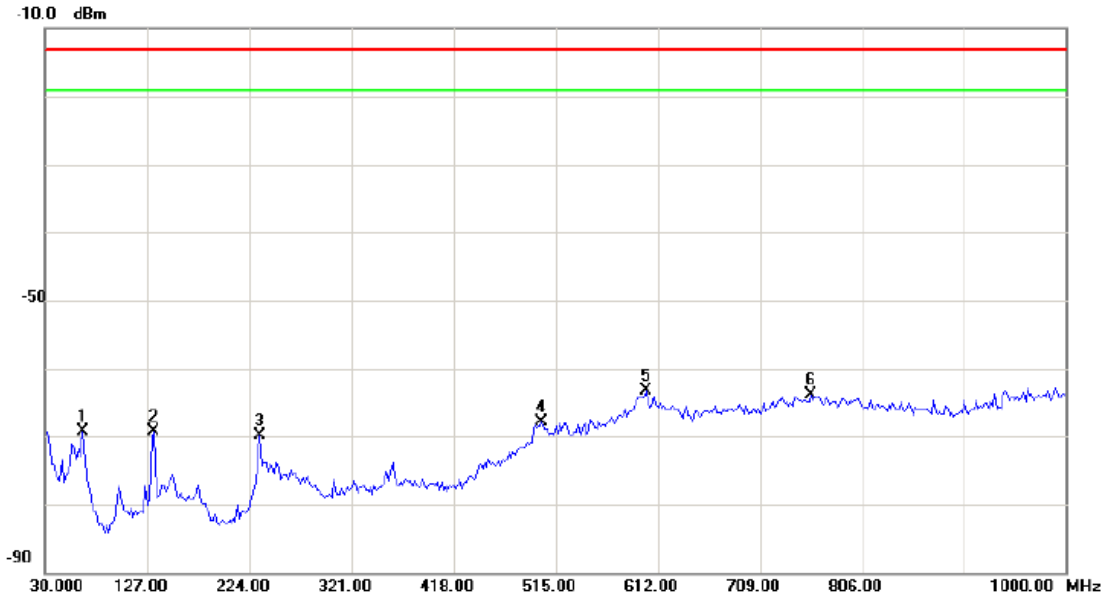

No.	Mk.	Freq. MHz	Reading Level dBm	Correct Factor dB	Measure- ment dBm	Limit dBm	Over dB	Detector	Comment
1		64.9200	-77.26	8.00	-69.26	-13.0	-56.26	peak	
2		132.8200	-69.15	-0.11	-69.26	-13.0	-56.26	peak	
3		233.7000	-71.87	1.90	-69.97	-13.0	-56.97	peak	
4		501.4200	-77.91	10.04	-67.87	-13.0	-54.87	peak	
5	*	600.3600	-80.11	16.80	-63.31	-13.0	-50.31	peak	
6		757.5000	-80.73	16.80	-63.93	-13.0	-50.93	peak	



Test Mode : TX CH190 EGPRS

Horizontal



No.	Mk.	Freq. MHz	Reading Level dBm	Correct Factor dB	Measure- ment dBm	Limit dBm	Over dB	Detector	Comment
1		97.9000	-73.09	3.29	-69.80	-13.0	-56.80	peak	
2		132.8200	-70.82	4.25	-66.57	-13.0	-53.57	peak	
3		239.5200	-72.78	0.56	-72.22	-13.0	-59.22	peak	
4		567.3800	-79.93	11.66	-68.27	-13.0	-55.27	peak	
5	*	664.3800	-75.17	11.29	-63.88	-13.0	-50.88	peak	
6		792.4200	-79.72	14.59	-65.13	-13.0	-52.13	peak	



Test Mode : TX CH251 EGPRS

Vertical

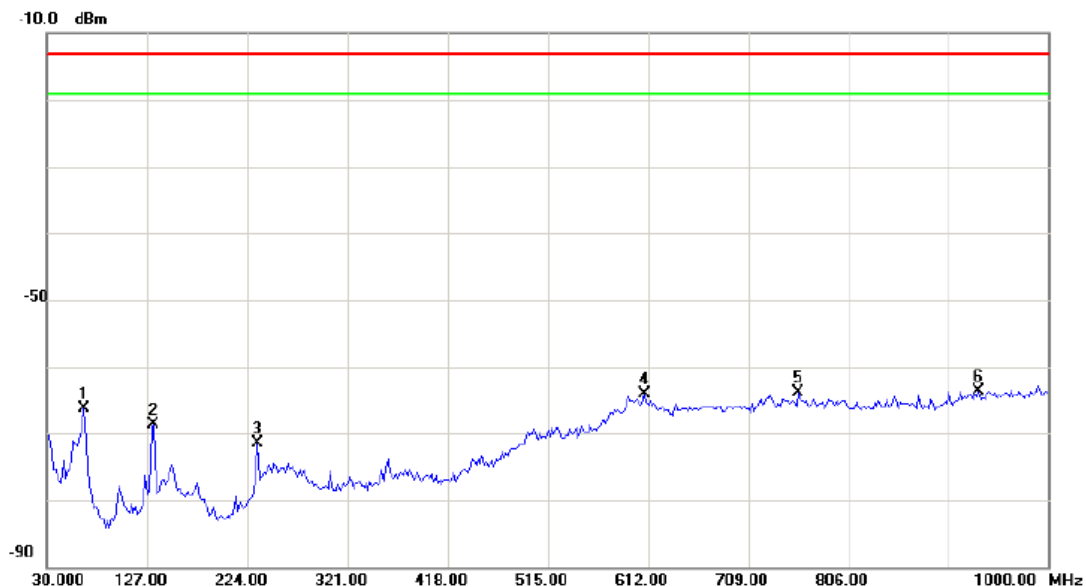

No.	Mk.	Freq. MHz	Reading Level dBm	Correct Factor dB	Measure- ment dBm	Limit dBm	Over dB	Detector	Comment
1		64.9200	-74.26	8.00	-66.26	-13.0	-53.26	peak	
2		132.8200	-68.65	-0.11	-68.76	-13.0	-55.76	peak	
3		233.7000	-73.37	1.90	-71.47	-13.0	-58.47	peak	
4		608.1200	-80.64	16.64	-64.00	-13.0	-51.00	peak	
5		757.5000	-80.73	16.80	-63.93	-13.0	-50.93	peak	
6	*	932.1000	-80.34	16.65	-63.69	-13.0	-50.69	peak	



Test Mode : TX CH251 EGPRS

**Horizontal**

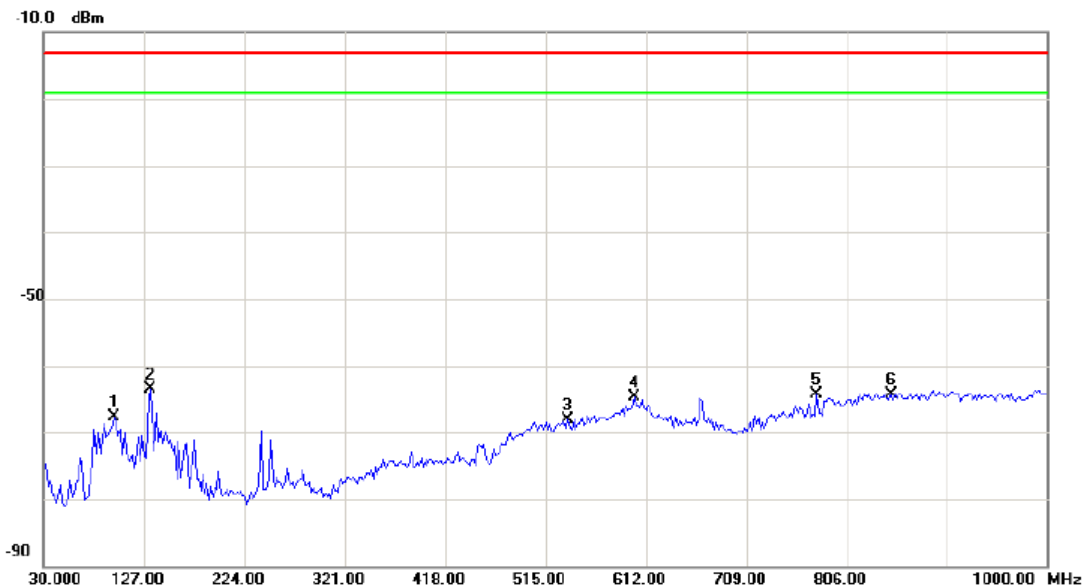

No. Mk.	Freq. MHz	Reading Level dBm	Correct Factor dB	Measure- ment dBm	Limit dBm	Over dB	Detector	Comment
1	97.9000	-71.09	3.29	-67.80	-13.0	-54.80	peak	
2 *	132.8200	-67.82	4.25	-63.57	-13.0	-50.57	peak	
3	536.3400	-78.58	10.53	-68.05	-13.0	-55.05	peak	
4	600.3600	-78.55	13.77	-64.78	-13.0	-51.78	peak	
5	776.9000	-78.83	14.56	-64.27	-13.0	-51.27	peak	
6	848.6800	-79.68	15.47	-64.21	-13.0	-51.21	peak	





#### **4.4.9 RESULTS OF TRANSMITTER SPURIOUS EMISSIONS ABOVE 1GHZ**

Remark :

- (1) Reading in which marked as Peak means measurements by using is Peak Mode with Detector SPA setting in RBW=1MHz, VBW =1MHz, Swp. Time = 0.3 sec./MHz ◦
- (2) All readings are Peak unless otherwise stated QP in column of 『Note』 . Peak denotes that the Peak reading compliance with the QP Limits and then QP Mode measurement didn't perform ◦
- (3) Measuring frequency range from 1GHz to 10GHz ◦
- (4) If the peak scan value lower limit more than 20dB, then this signal data does not show in table ◦



Test Mode : TX CH128 GSM

Vertical

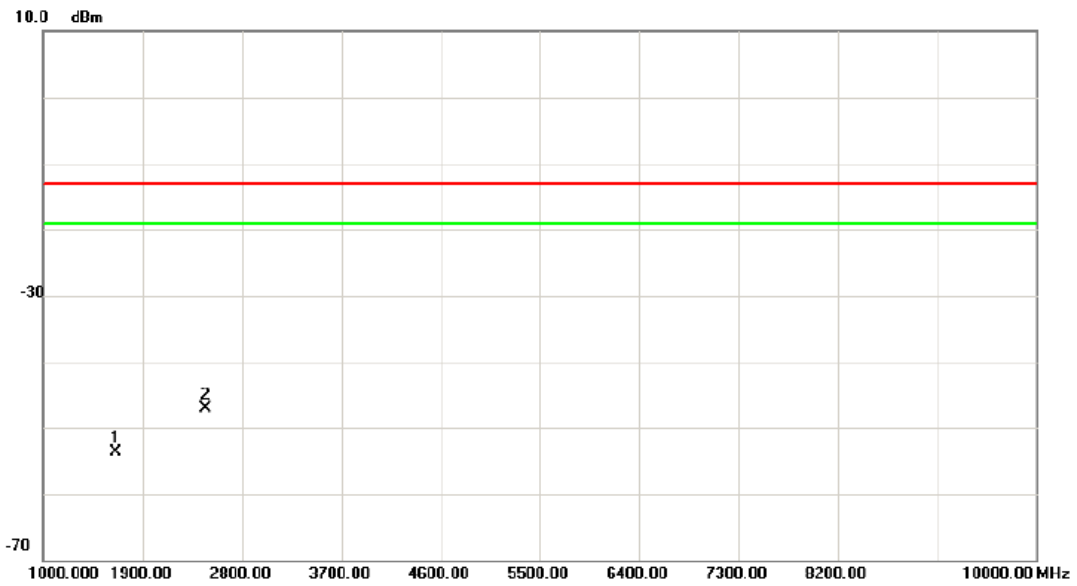

No. Mk.	Freq. MHz	Reading Level dBm	Correct Factor dB	Measurement dBm	Limit dBm	Over dB	Detector	Comment
1	1649.700	-55.38	1.71	-53.67	-13.0	-40.67	peak	
2 *	2470.100	-51.04	3.88	-47.16	-13.0	-34.16	peak	



Test Mode : TX CH128 GSM

**Horizontal**

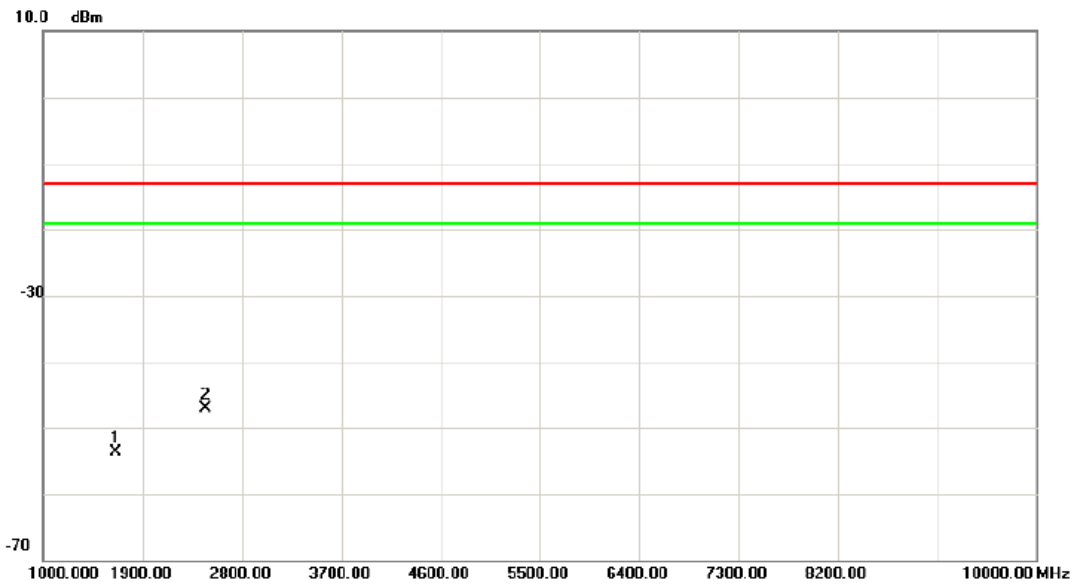

No.	Mk.	Freq. MHz	Reading Level dBm	Correct Factor dB	Measure- ment dBm	Limit dBm	Over dB	Detector	Comment
1		1649.700	-55.38	1.71	-53.67	-13.0	-40.67	peak	
2	*	2470.100	-51.04	3.88	-47.16	-13.0	-34.16	peak	



Test Mode : TX CH190 GSM

Vertical

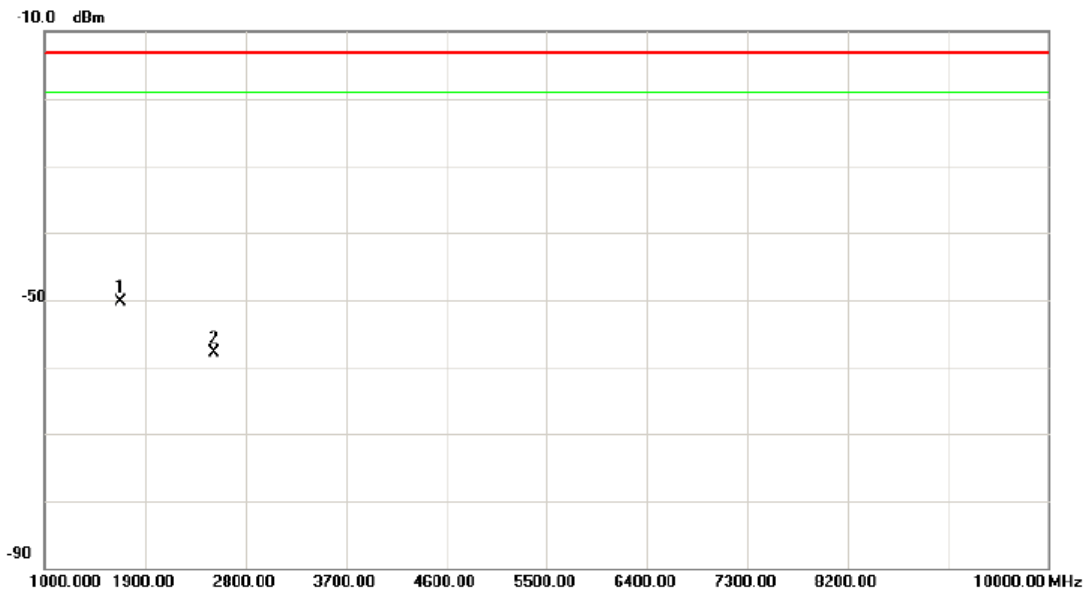

No.	Mk.	Freq. MHz	Reading Level dBm	Correct Factor dB	Measure- ment dBm	Limit dBm	Over dB	Detector	Comment
1	*	1676.600	-53.47	3.18	-50.29	-13.0	-37.29	peak	
2		2514.900	-59.72	1.85	-57.87	-13.0	-44.87	peak	



Test Mode : TX CH190 GSM

**Horizontal**

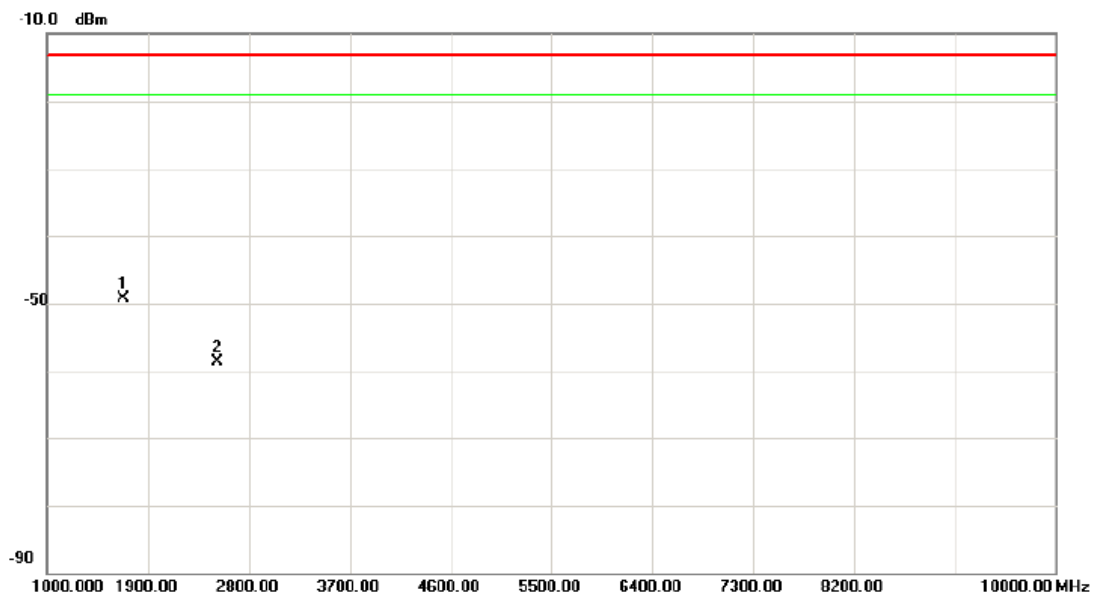

No.	Mk.	Freq. MHz	Reading Level dBm	Correct Factor dB	Measure- ment dBm	Limit dBm	Over dB	Detector	Comment
1	*	1676.200	-52.52	3.17	-49.35	-13.0	-36.35	peak	
2		2514.900	-60.49	1.85	-58.64	-13.0	-45.64	peak	



Test Mode : TX CH251 GSM

**Vertical**

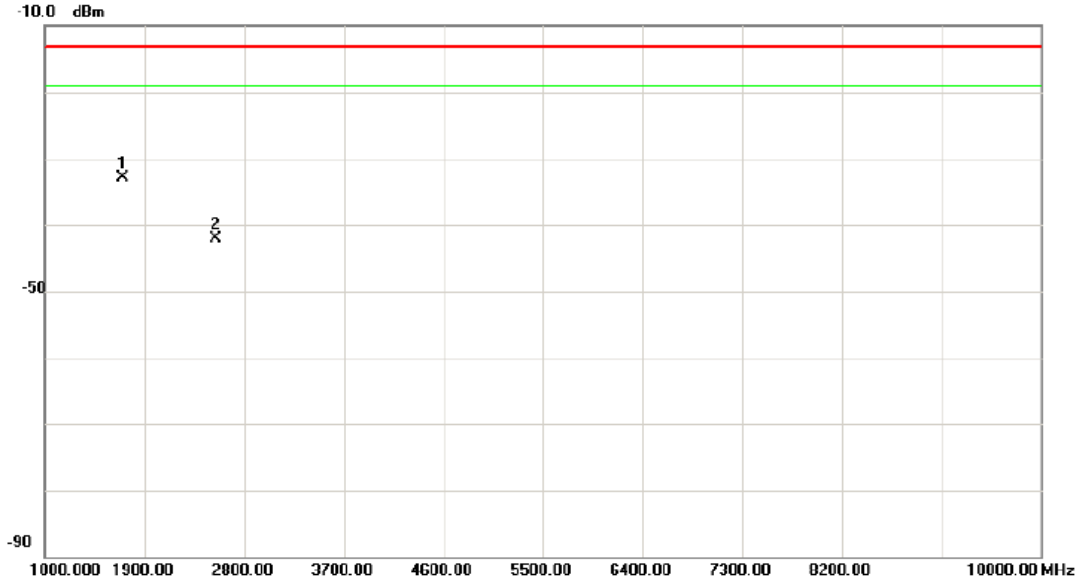

No. Mk.	Freq. MHz	Reading Level dBm	Correct Factor dB	Measurement dBm	Limit dBm	Over dB	Detector	Comment
1 *	1696.600	-35.08	2.14	-32.94	-13.0	-19.94	peak	
2	2546.900	-46.09	3.94	-42.15	-13.0	-29.15	peak	



Test Mode : TX CH251 GSM

**Horizontal**

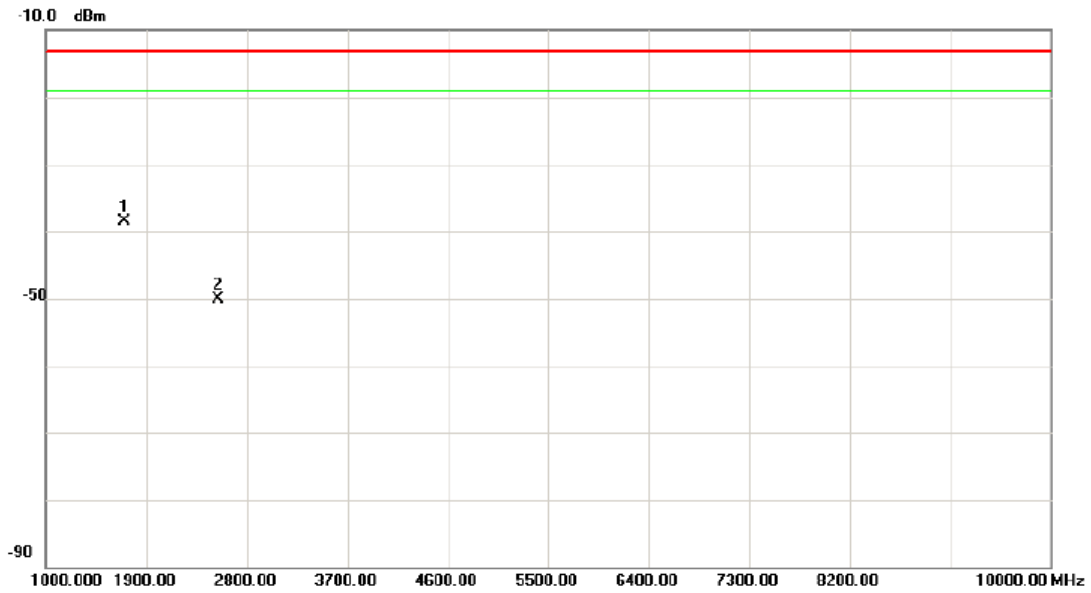

No.	Mk.	Freq. MHz	Reading Level dBm	Correct Factor dB	Measure- ment dBm	Limit dBm	Over dB	Detector	Comment
1	*	1696.600	-40.69	2.14	-38.55	-13.0	-25.55	peak	
2		2546.900	-54.09	3.94	-50.15	-13.0	-37.15	peak	



Test Mode : TX CH128 EGPRS

**Vertical**

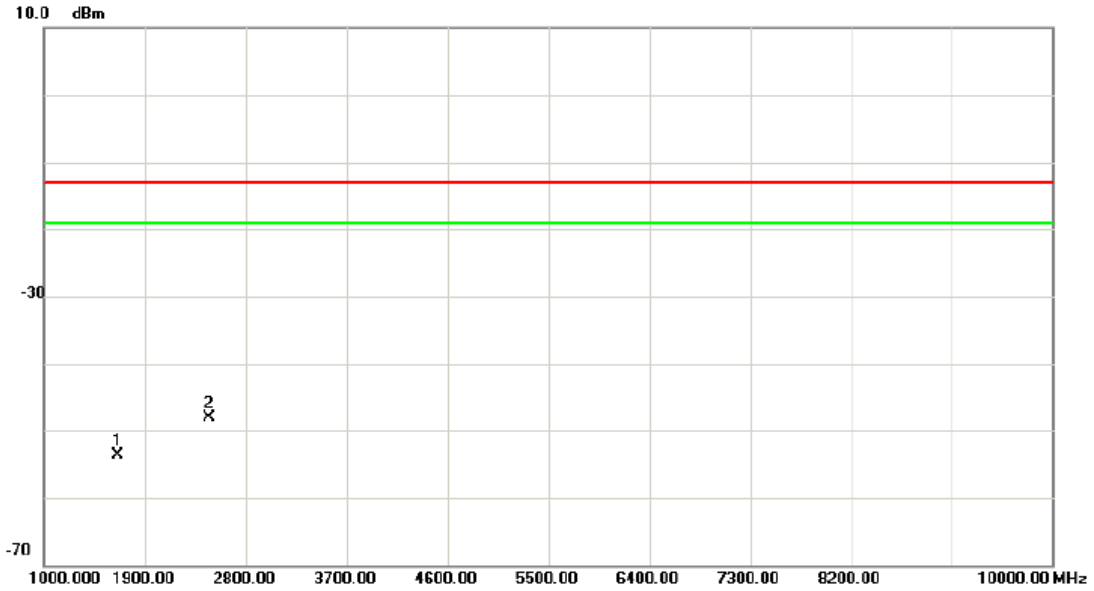

No.	Mk.	Freq. MHz	Reading Level dBm	Correct Factor dB	Measure- ment dBm	Limit dBm	Over dB	Detector	Comment
1		1649.860	-55.39	1.71	-53.68	-13.0	-40.68	peak	
2	*	2470.510	-52.06	3.88	-48.18	-13.0	-35.18	peak	





Test Mode : TX CH128 EGPRS

**Horizontal**

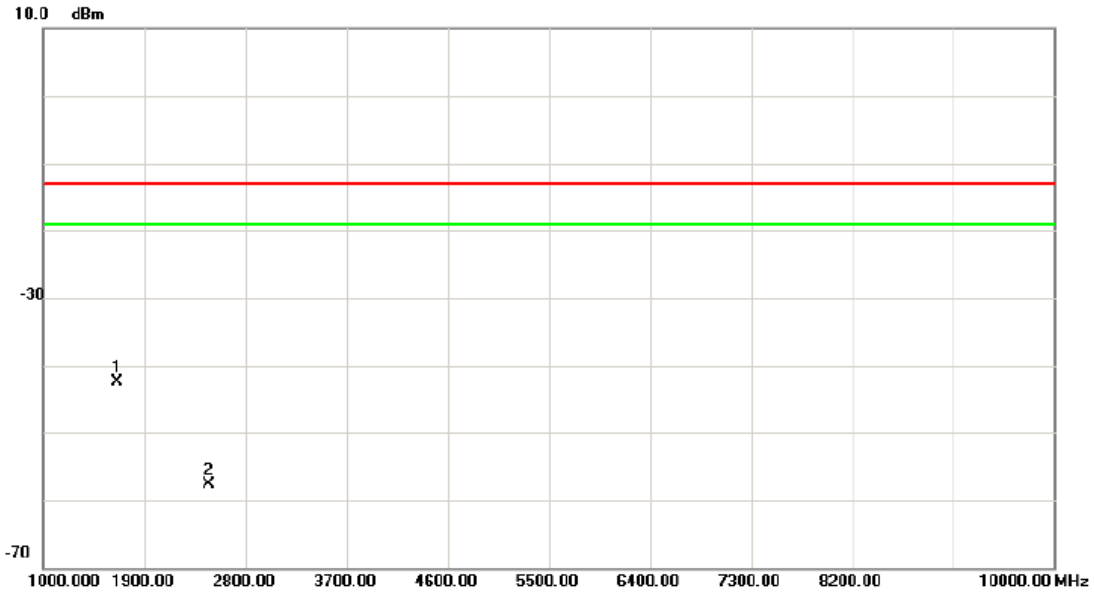

No.	Mk.	Freq. MHz	Reading Level dBm	Correct Factor dB	Measure- ment dBm	Limit dBm	Over dB	Detector	Comment
1	*	1649.360	-45.52	2.96	-42.56	-13.0	-29.56	peak	
2		2470.360	-59.68	2.07	-57.61	-13.0	-44.61	peak	



Test Mode : TX CH190 EGPRS

Vertical

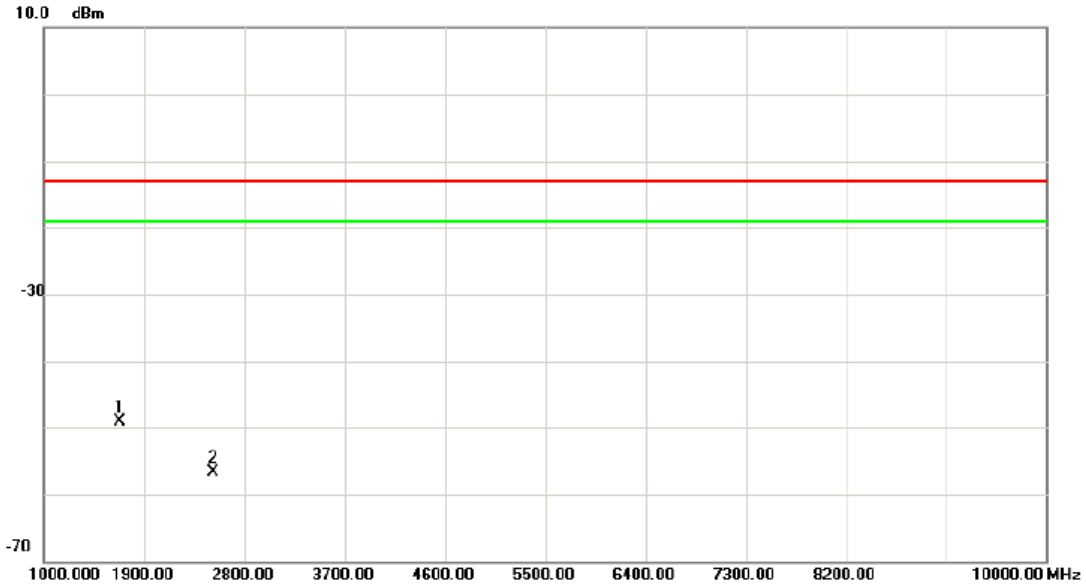

No.	Mk.	Freq. MHz	Reading Level dBm	Correct Factor dB	Measure- ment dBm	Limit dBm	Over dB	Detector	Comment
1	*	1676.580	-52.36	3.18	-49.18	-13.0	-36.18	peak	
2		2514.870	-58.56	1.85	-56.71	-13.0	-43.71	peak	



Test Mode : TX CH190 EGPRS

Horizontal

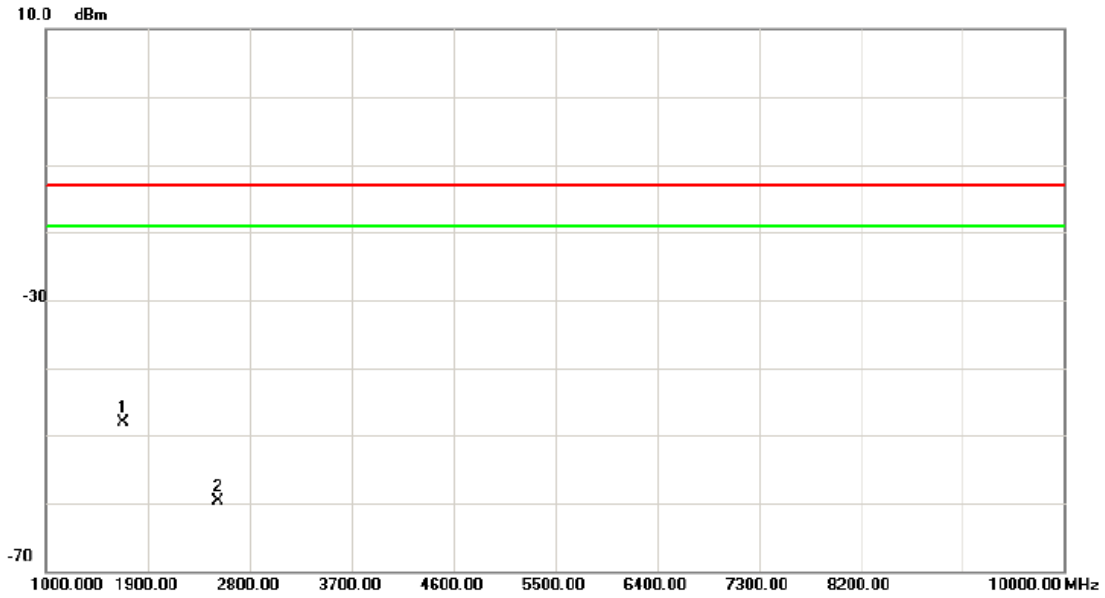

No.	Mk.	Freq. MHz	Reading Level dBm	Correct Factor dB	Measure- ment dBm	Limit dBm	Over dB	Detector	Comment
1	*	1676.250	-51.36	3.18	-48.18	-13.0	-35.18	peak	
2		2514.760	-61.55	1.85	-59.70	-13.0	-46.70	peak	



Test Mode : TX CH251 EGPRS

Vertical

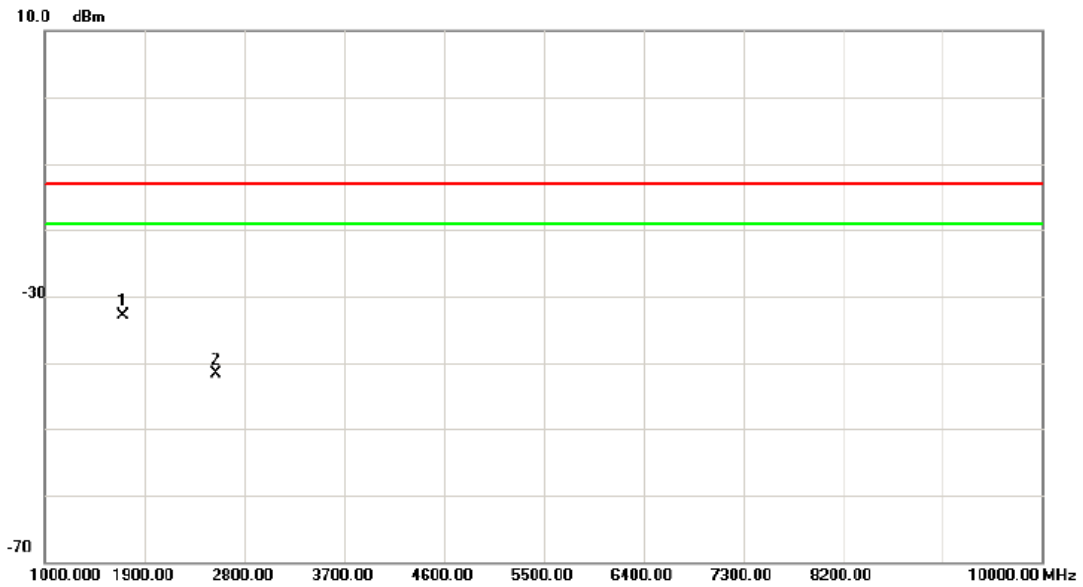

No.	Mk.	Freq. MHz	Reading Level dBm	Correct Factor dB	Measure- ment dBm	Limit dBm	Over dB	Detector	Comment
1	*	1696.650	-35.12	2.14	-32.98	-13.0	-19.98	peak	
2		2546.870	-45.56	3.94	-41.62	-13.0	-28.62	peak	



Test Mode : TX CH251 EGPRS

**Horizontal**

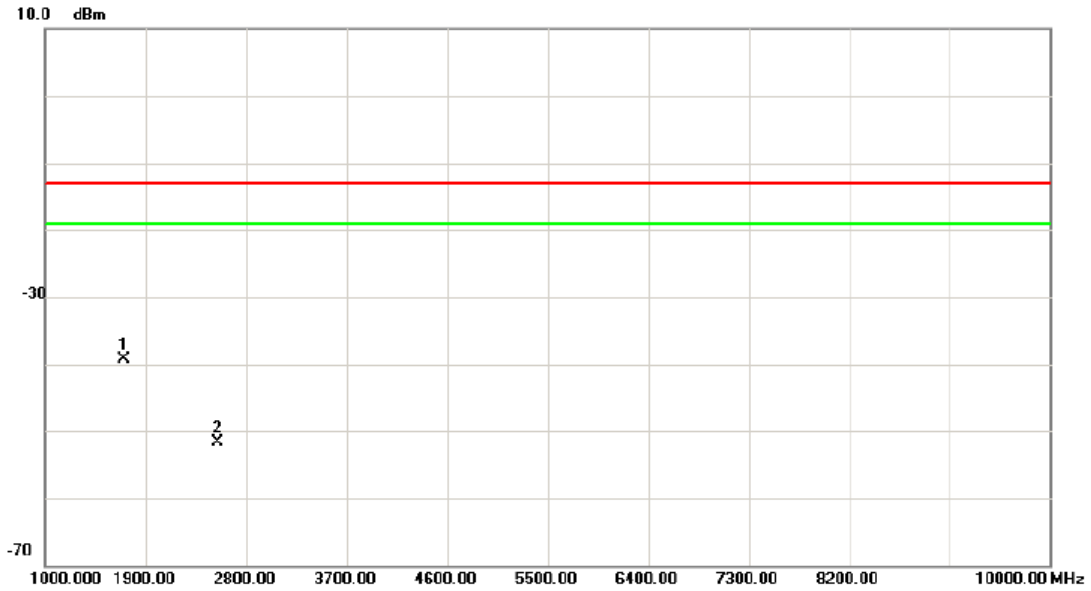

No.	Mk.	Freq. MHz	Reading Level dBm	Correct Factor dB	Measure- ment dBm	Limit dBm	Over dB	Detector	Comment
1	*	1696.580	-41.52	2.14	-39.38	-13.0	-26.38	peak	
2		2546.360	-55.66	3.94	-51.72	-13.0	-38.72	peak	



#### 4.5 BAND EDGE MEASUREMENT

##### 4.5.1 LIMIT

According to FCC 22.917(a)&RSS-132 section 5.5 specified that power of any emission outside of the authorized operating frequency ranges must be attenuated below the transmitting power (P) by a factor of at least  $43 + 10 \log(P)$  dB . In the 1 MHz bands immediately outside and adjacent to the frequency block a resolution bandwidth of at least one percent of the emission bandwidth of the fundamental emission of the transmitter may be employed. Then we measure that the bandwidth is about 300kHz and the resolution bandwidth is 3kHz.

##### 4.5.2 MEASURING INSTRUMENTS AND SETTING

Please refer to section 5 in this report. The following table is the setting of the Spectrum Analyzer.

Spectrum Parameters	Setting
Attenuation	Auto
Span Frequency	5 MHz
RB / VB	10 kHz /30 kHz
Trace	Sample
Sweep Time	Auto

##### 4.5.3 TEST PROCEDURES

1. The EUT was set up for the maximum peak power with **GSM/EGPRS** link data modulation. The power was measured with R&S Spectrum Analyzer. All measurements were done at 2 channels, 128 and 251(low and high operational frequency range.)
2. The band edge measurement used the power splitter via EUT RF power connector between simulation base station and spectrum analyzer. The splitter loss and cable loss are the worst loss 4dB in the transmitted path track.
3. The center frequency of spectrum is the band edge frequency and span is 2 MHz. RB of the spectrum is 10kHz and VB of the spectrum is 30KHz.
4. Record the Sample trace plot into the test report.

##### 4.5.4 TEST SETUP LAYOUT

This test setup layout is the same as that shown in section 4.2.4.

##### 4.5.5 TEST DEVIATION

There is no deviation with the original standard.

##### 4.5.6 EUT OPERATION DURING TEST

The BS simulator was used to set the TX channel and power level and modulate the TX signal.

##### 4.5.7 EUT TEST CONDITIONS

Temperature: 25°C  
Relative Humidity: 55%  
Test Voltage: 3.7V



### 4.5.8 TEST RESULTS OF BAND EDGE

#### Band Edge on Configuration GSM / Channel 128-CONDUCTED MODE

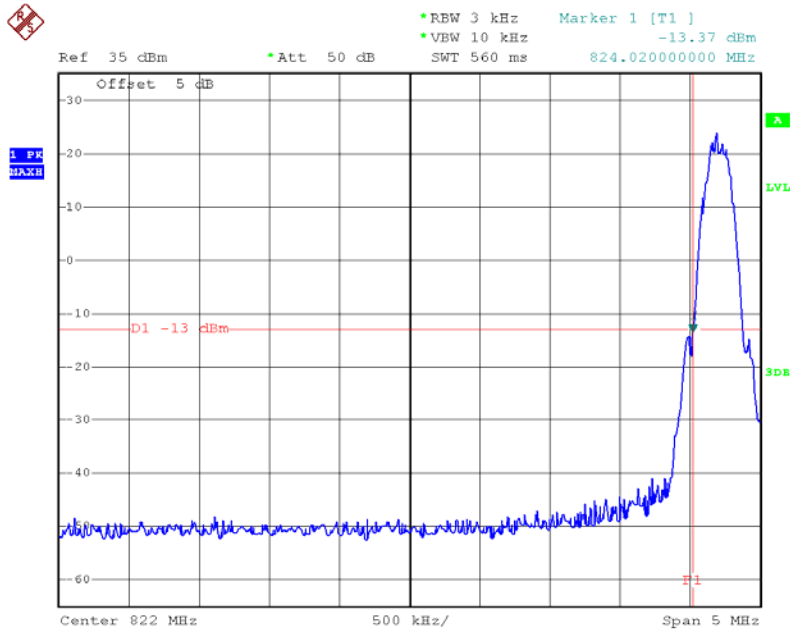

Date: 20.MAR.2014 20:16:22

#### Band Edge on Configuration GSM / Channel 251-CONDUCTED MODE

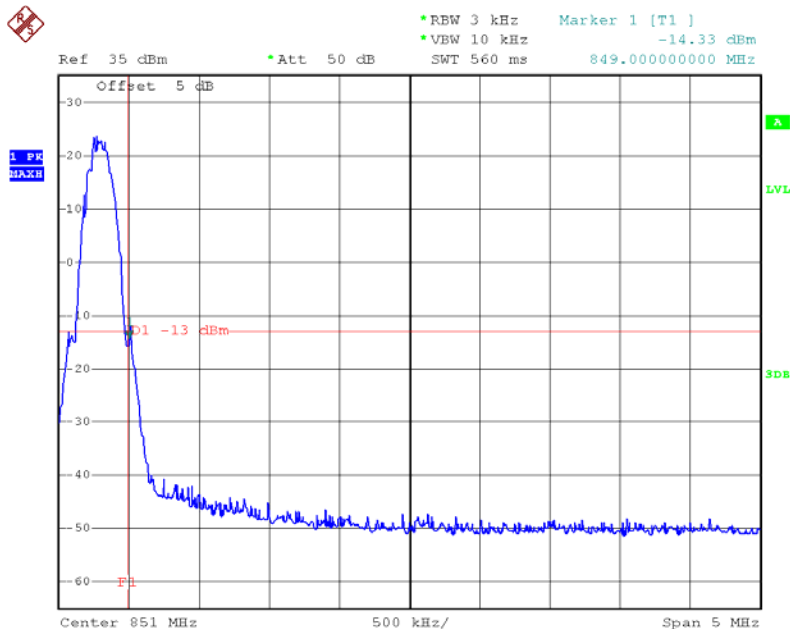

Date: 20.MAR.2014 20:14:23



### Band Edge on Configuration EGPRS / Channel 128-CONDUCTED MODE

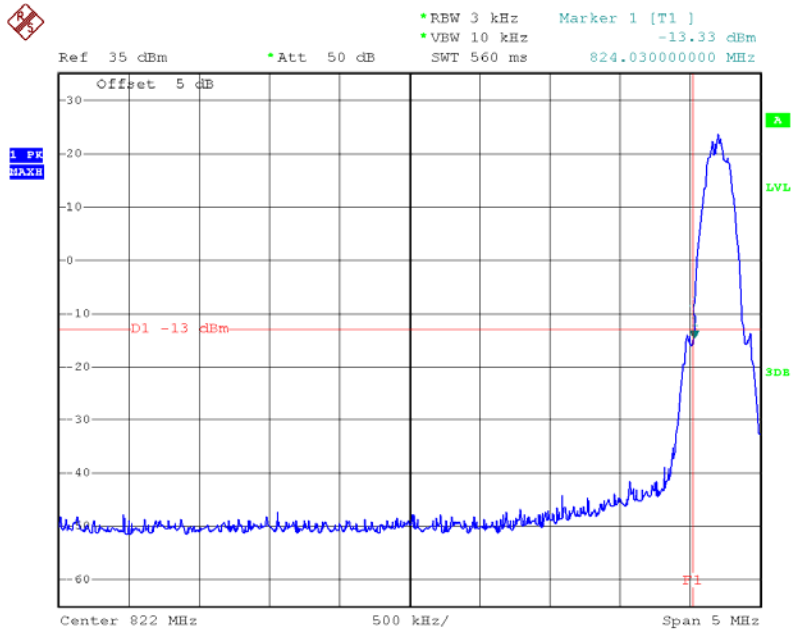

Date: 20.MAR.2014 20:17:27

### Band Edge on Configuration EGPRS / Channel 251-CONDUCTED MODE

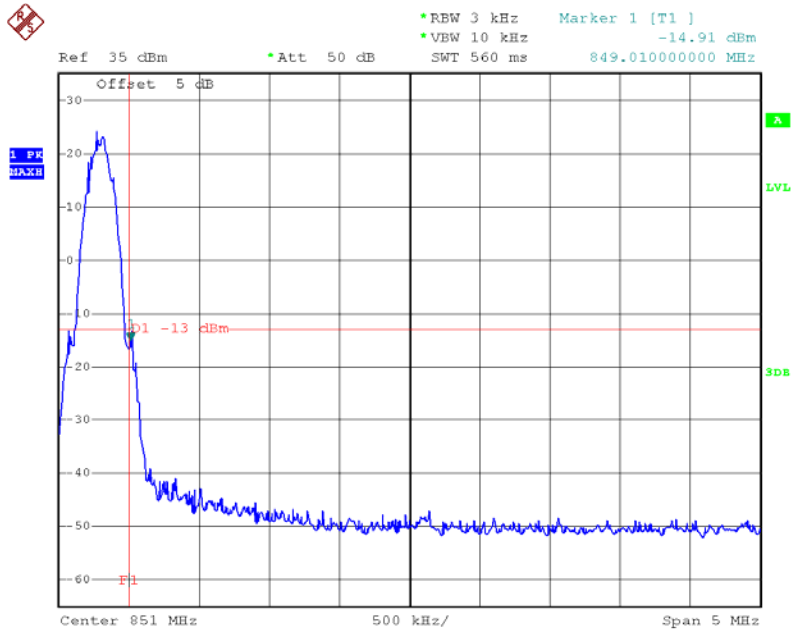

Date: 20.MAR.2014 20:15:29



## 4.6 FREQUENCY STABILITY MEASUREMENT

### 4.6.1 LIMIT

According to the FCC part 22.355&RSS-132 section 5.3 shall be tested the frequency stability. The rule is defined that "The frequency stability shall be sufficient to ensure that the fundamental emission stays within the authorized frequency block." The frequency error rate is according to the JTC standard that the frequency error rate shall be accurate to within 2.5 ppm of the received frequency from the base station. The test extreme voltage is according to the 2.1055(d)(1) Vary primary supply voltage from 85 to 115 percent of the nominal value for other than hand carried battery equipment and the extreme temperature rule is comply with the 2.1055(a)(1)  $-30^{\circ}\text{C}\sim 50^{\circ}\text{C}$ .

### 4.6.2 MEASURING INSTRUMENTS AND SETTING

Please refer to section 5 in this report. The following table is the setting of the BS Simulator.

Spectrum Parameters	Setting
Frequency Error	The maximum of transmit frequency error

### 4.6.3 TEST PROCEDURES

1. The transmitter output (antenna port) was connected to the BS Simulator.
2. The BS simulator was used to set the TX channel and power level and modulate the TX signal with different bit patterns.
3. BS simulator used the frequency error function and measured the peak frequency error. Power must be removed when changing from one temperature to another or one voltage to another voltage. Power warm up is at least 15 min and power applied should perform before recording frequency error. The each temperature step shall be at least 0.5 hours, consider the EUT could be test under the stability condition.
4. EUT is connected the external power supply to control the DC input power. The various Volts from the minimum 3.1 Volts to 4.3 Volts. Each step shall be record the frequency error rate.
5. The test extreme voltage is to change the primary supply voltage from 85 to 115 percent of the nominal value.
6. Extreme temperature rule is  $0^{\circ}\text{C}\sim 40^{\circ}\text{C}$ .

### 4.6.4 TEST SETUP LAYOUT

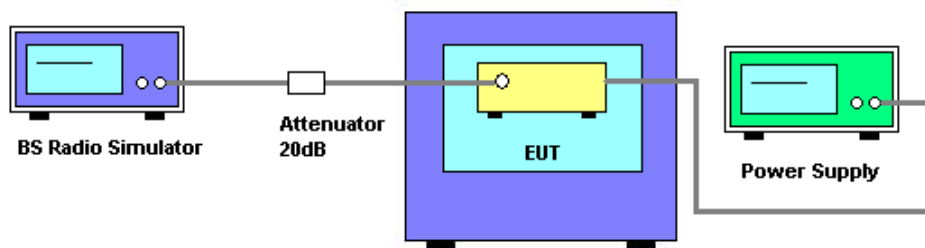

### 4.6.5 TEST DEVIATION

There is no deviation with the original standard.

### 4.6.6 EUT OPERATION DURING TEST

The EUT was programmed to be in continuously un-modulation transmitting mode.



**4.6.7 EUT TEST CONDITIONS**

Temperature: 25°C

Relative Humidity: 55%

Test Voltage: 3.7V



**4.6.8 RESULTS OF FREQUENCY STABILITY**

Test Mode : TX CH 128 GSM

**Voltage vs. Frequency Stability**

Voltage(Volts)	Frequency Error (Hz)	Frequency Error (ppm)	Limit(ppm)
3.5	11	0.013346275	0.1
3.6	13	0.015772871	0.1
3.7	12	0.014559573	0.1
3.8	12	0.014559573	0.1
3.9	13	0.015772871	0.1
4.0	11	0.013346275	0.1
4.1	14	0.016986168	0.1
4.2	17	0.020626062	0.1
Max. Deviation (ppm)	<b>17</b>	<b>0.020626062</b>	<b>0.1</b>

**Temperature vs. Frequency Stability**

Temperature(°C)	Frequency Error (Hz)	Frequency Error (ppm)	Limit(ppm)
40	19	0.023052657	0.1
30	18	0.021839359	0.1
20	18	0.021839359	0.1
10	13	0.015772871	0.1
0	17	0.020626062	0.1
Max. Deviation (ppm)	<b>19</b>	<b>0.023052657</b>	<b>0.1</b>



Test Mode : TX CH 128 EGPRS

**Voltage vs. Frequency Stability**

Voltage(Volts)	Frequency Error (Hz)	Frequency Error (ppm)	Limit(ppm)
3.5	11	0.013346275	0.1
3.6	13	0.015772871	0.1
3.7	12	0.014559573	0.1
3.8	12	0.014559573	0.1
3.9	13	0.015772871	0.1
4.0	12	0.014559573	0.1
4.1	11	0.013346275	0.1
4.2	14	0.016986168	0.1
Max. Deviation (ppm)	<b>14</b>	<b>0.016986168</b>	<b>0.1</b>

**Temperature vs. Frequency Stability**

Temperature(°C)	Frequency Error (Hz)	Frequency Error (ppm)	Limit(ppm)
45	17	0.020626062	0.1
30	15	0.018199466	0.1
20	15	0.018199466	0.1
10	14	0.016986168	0.1
0	16	0.019412764	0.1
Max. Deviation (ppm)	<b>17</b>	<b>0.020626062</b>	<b>0.1</b>



**4.7 CONDUCTED EMISSION MEASUREMENT**

**4.7.1 POWER LINE CONDUCTED EMISSION Limits (Frequency Range 150KHz-30MHz)**

FREQUENCY (MHz)	Class A (dBuV)		Class B (dBuV)		Standard
	Quasi-peak	Average	Quasi-peak	Average	
0.15 -0.5	79.00	66.00	66 - 56 *	56 - 46 *	CISPR
0.50 -5.0	73.00	60.00	56.00	46.00	CISPR
5.0 -30.0	73.00	60.00	60.00	50.00	CISPR

0.15 -0.5	79.00	66.00	66 - 56 *	56 - 46 *	FCC
0.50 -5.0	73.00	60.00	56.00	46.00	FCC
5.0 -30.0	73.00	60.00	60.00	50.00	FCC

Note:

- (1) The tighter limit applies at the band edges.
- (2) The limit of " \* " marked band means the limitation decreases linearly with the logarithm of the frequency in the range.

The following table is the setting of the receiver

Receiver Parameters	Setting
Attenuation	10 dB
Start Frequency	0.15 MHz
Stop Frequency	30 MHz
IF Bandwidth	9 kHz

#### 4.7.2 TEST PROCEDURE

- The EUT was placed 0.8 meters from the horizontal ground plane with EUT being connected to the power mains through a line impedance stabilization network (LISN). All other support equipments powered from additional LISN(s). The LISN provide 50 Ohm/ 50uH of coupling impedance for the measuring instrument.
- Interconnecting cables that hang closer than 40 cm to the ground plane shall be folded back and forth in the center forming a bundle 30 to 40 cm long.
- I/O cables that are not connected to a peripheral shall be bundled in the center. The end of the cable may be terminated, if required, using the correct terminating impedance. The overall length shall not exceed 1 m.
- LISN at least 80 cm from nearest part of EUT chassis.
- For the actual test configuration, please refer to the related Item –EUT Test Photos.

#### 4.7.3 DEVIATION FROM TEST STANDARD

No deviation

#### 4.7.4 TEST SETUP

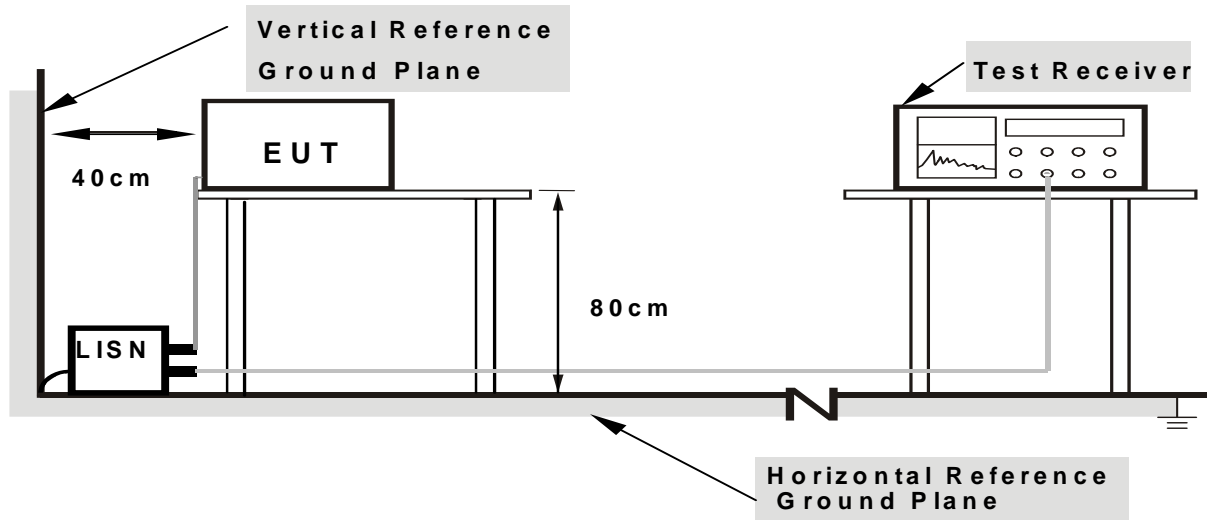

**Note: 1. Support units were connected to second LISN.**

**2. Both of LISNs (AMN) are 80 cm from EUT and at least 80 from other units and other metal planes**

#### 4.7.5 EUT OPERATING CONDITIONS

The EUT was configured for testing in a typical fashion (as a customer would normally use it). The EUT has been programmed to continuously transmit during test. This operating condition was tested and used to collect the included data.

#### 4.7.6 EUT TEST CONDITIONS

Temperature: 25°C

Relative Humidity: 55%

Test Voltage: 120V/60Hz



#### **4.7.7 TEST RESULTS**

**Remark:**

- (1) All readings are QP Mode value unless otherwise stated AVG in column of 'Note'. If the QP Mode Measured value compliance with the QP Limits and lower than AVG Limits, the EUT shall be deemed to meet both QP & AVG Limits and then only QP Mode was measured, but AVG Mode didn't perform. In this case, a " \* " marked in AVG Mode column of Interference Voltage Measured.
- (2) Measuring frequency range from 150KHz to 30MHz.



Test Mode : TX Mode

Line

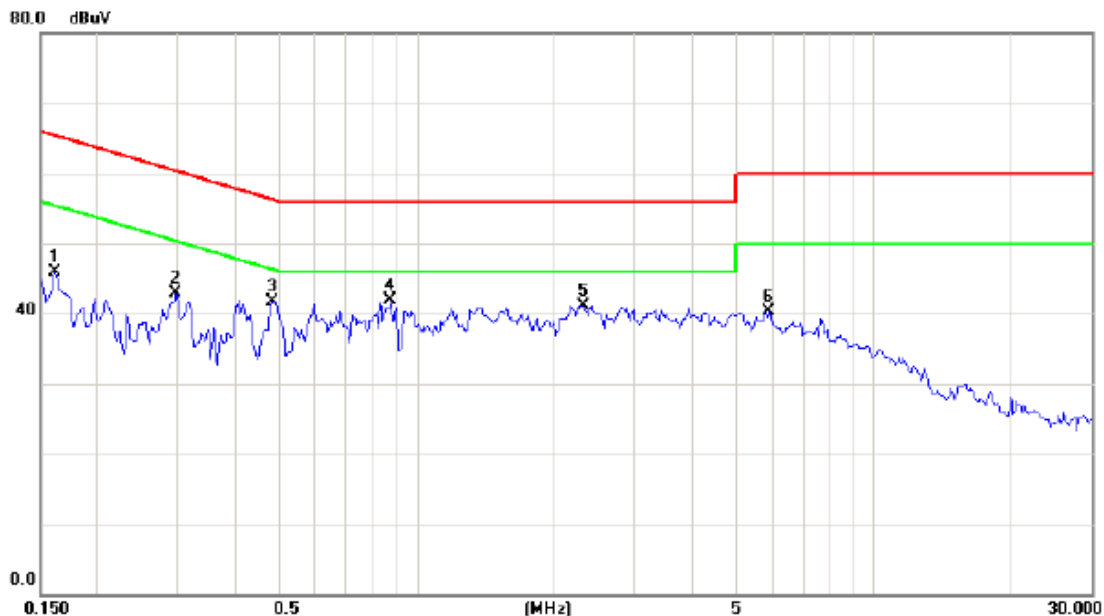

No.	Mk.	Freq. MHz	Reading Level dBuV	Correct Factor dB	Measure- ment dBuV	Limit dBuV	Over dB	Detector	Comment
1		0.1617	36.41	9.52	45.93	65.38	-19.45	peak	
2		0.2983	33.32	9.54	42.86	60.29	-17.43	peak	
3		0.4860	32.22	9.55	41.77	56.24	-14.47	peak	
4	*	0.8765	32.28	9.57	41.85	56.00	-14.15	peak	
5		2.3180	31.53	9.59	41.12	56.00	-14.88	peak	
6		5.9257	30.70	9.64	40.34	60.00	-19.66	peak	





Test Mode : TX Mode

**Neutral**

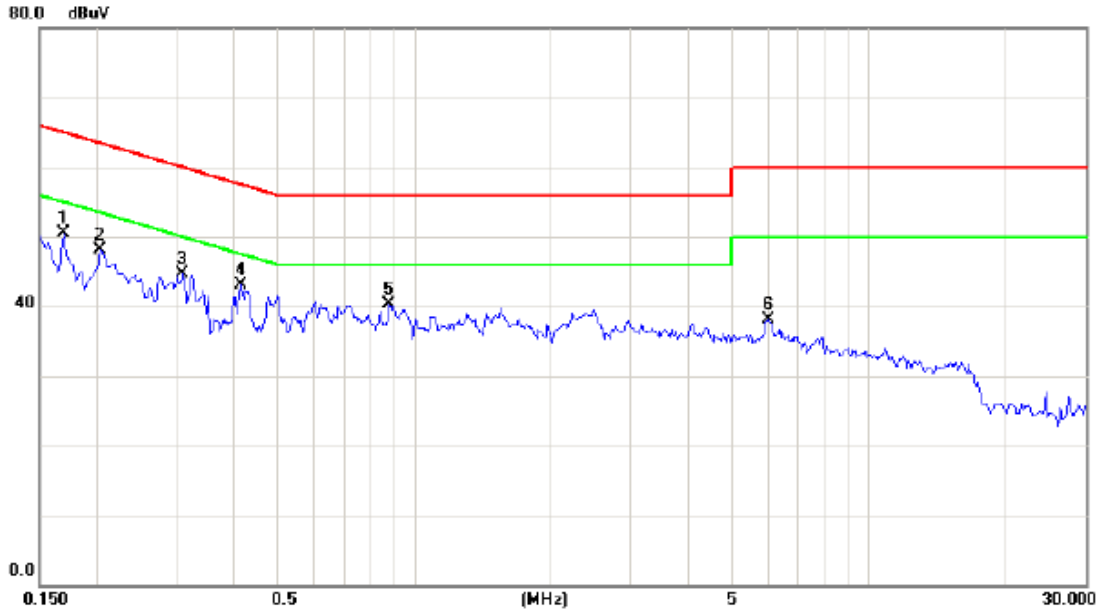

No.	Mk.	Freq. MHz	Reading Level dBuV	Correct Factor dB	Measure- ment dBuV	Limit dBuV	Over dB	Detector	Comment
1		0.1695	40.83	9.59	50.42	64.98	-14.56	peak	
2		0.2046	38.57	9.59	48.16	63.42	-15.26	peak	
3		0.3100	35.17	9.59	44.76	59.97	-15.21	peak	
4	*	0.4156	33.59	9.59	43.18	57.54	-14.36	peak	
5		0.8802	30.73	9.60	40.33	56.00	-15.67	peak	
6		5.9960	28.34	9.67	38.01	60.00	-21.99	peak	



**5. LIST OF MEASUREMENT EQUIPMENTS**

<b>Conducted Emission Measurement</b>					
Item	Kind of Equipment	Manufacturer	Type No.	Serial No.	Calibrated until
1	LISN	EMCO	3816/2	00052765	Apr. 25, 2014
2	LISN	R&S	ENV216	100087	Nov. 11, 2014
3	Test Cable	N/A	C_17	N/A	Mar. 14, 2015
4	EMI TEST RECEIVER	R&S	ESCS30	833364/017	Nov. 11, 2014
5	50Ω Terminator	SHX	TF2-3G-A	08122902	Apr. 25, 2014

<b>Radiated Emission Measurement</b>					
Item	Kind of Equipment	Manufacturer	Type No.	Serial No.	Calibrated until
1	Antenna	Schwarbeck	VULB9160	9160-3232	Apr. 25, 2014
2	Amplifier	HP	8447D	2944A09673	Apr. 25, 2014
3	Test Receiver	R&S	ESCI	100382	Apr. 25, 2014
4	Test Cable	N/A	C-01_CB03	N/A	Jul. 02, 2014
5	Antenna	ETS	3115	00075789	Apr. 25, 2014
6	Amplifier	Agilent	8449B	3008A02274	Apr. 25, 2014
7	Spectrum	Agilent	E4408B	US39240143	Nov. 11, 2014
8	Test Cable	HUBER+SUHNER	C-45	N/A	Apr. 30, 2014
9	Controller	CT	SC100	N/A	N/A
10	Horn Antenna	EMCO	3115	9605-4803	Apr. 25, 2014
11	Active Loop Antenna	R&S	HFH2-Z2	830749/020	Apr. 25, 2014
12	Broad-Band Horn Antenna	Schwarzbeck	BBHA 9170	9170319	Oct. 22, 2014

<b>Antenna Conducted Spurious Emission Measurement</b>					
Item	Kind of Equipment	Manufacturer	Type No.	Serial No.	Calibrated until
1	Spectrum Analyzer	R&S	FSP 40	100185	Nov. 11, 2014

<b>Band Edge Measurement</b>					
Item	Kind of Equipment	Manufacturer	Type No.	Serial No.	Calibrated until
1	Spectrum Analyzer	R&S	FSP 40	100185	Nov. 11, 2014

<b>99% Occupied Bandwidth Measurement</b>					
Item	Kind of Equipment	Manufacturer	Type No.	Serial No.	Calibrated until
1	Spectrum Analyzer	R&S	FSP 40	100185	Nov. 11, 2014



Frequency Stability Measurement					
Item	Kind of Equipment	Manufacturer	Type No.	Serial No.	Calibrated until
1	Spectrum Analyzer	R&S	FSP 40	100185	Nov. 11, 2014
2	Precision Oven Tester	HOLINK	H-T-1F-D	BA03101701	May. 25, 2014

Remark: "N/A" denotes no model name, serial no. or calibration specified.  
All calibration period of equipment list is one year.