



Neutron Engineering Inc.

FCC&IC Radio Test Report

FCC ID: VOB-P1988

IC: 7361A-P1988

This report concerns (check one): Original Grant Class II Change

Issued Date : Mar. 10, 2014
Project No. : 1402C004
Equipment : Tablet
Model Name : P1988
Applicant : NVIDIA CORPORATION
Address : 2701 SAN TOMAS EXPRESSWAY, SANTA CLARA, CALIFORNIA 95050, UNITED STATES OF AMERICA

Tested by: Neutron Engineering Inc. EMC Laboratory

Date of Receipt: Feb. 10, 2014

Date of Test: Feb. 10, 2014 ~ Mar. 07, 2014

Testing Engineer :

David Mao

(David Mao)

Technical Manager :

Leo Hung

(Leo Hung)

Authorized Signatory :

Steven Lu

(Steven Lu)

Neutron Engineering Inc.

No.3, Jinshagang 1st Road, ShiXia,

Dalang Town, Dong Guan, China.

TEL: 0769-8318-3000

FAX: 0769-8319-6000



Declaration

Neutron represents to the client that testing is done in accordance with standard procedures as applicable and that test instruments used has been calibrated with the standards traceable to National Measurement Laboratory (**NML**) of **CHINA**, or National Institute of Standards and Technology (**NIST**) of **U.S.A.**

Neutron's reports apply only to the specific samples tested under conditions. It is manufacture's responsibility to ensure that additional production units of this model are manufactured with the identical electrical and mechanical components. **Neutron** shall have no liability for any declarations, inferences or generalizations drawn by the client or others from **Neutron** issued reports.

Neutron's reports must not be used by the client to claim product endorsement by the authorities or any agency of the Government.

This report is the confidential property of the client. As a mutual protection to the clients, the public and **Neutron-self**, extracts from the test report shall not be reproduced except in full with **Neutron's** authorized written approval.

Neutron's laboratory quality assurance procedures are in compliance with the **ISO Guide 17025** requirements, and accredited by the conformity assessment authorities listed in this test report.

Limitation

For the use of the authority's logo is limited unless the Test Standard(s)/Scope(s)/Item(s) mentioned in this test report is (are) included in the conformity assessment authorities acceptance respective.



Table of Contents	Page
REPORT ISSUED HISTORY	6
1 . CERTIFICATION	7
2 . SUMMARY OF TEST RESULTS	8
2.1 TEST FACILITY	9
2.2 MEASUREMENT UNCERTAINTY	9
3 . GENERAL INFORMATION	10
3.1 GENERAL DESCRIPTION OF EUT	10
3.2 DESCRIPTION OF TEST MODES	12
3.3 TABLE OF PARAMETERS OF TEXT SOFTWARE SETTING	12
3.4 BLOCK DIAGRAM SHOWING THE CONFIGURATION OF SYSTEM TESTED	13
3.5 DESCRIPTION OF SUPPORT UNITS	13
4 . EMC EMISSION TEST	14
4.1 CONDUCTED EMISSION MEASUREMENT	14
4.1.1 POWER LINE CONDUCTED EMISSION LIMITS	14
4.1.2 TEST PROCEDURE	14
4.1.3 DEVIATION FROM TEST STANDARD	14
4.1.4 TEST SETUP	15
4.1.5 EUT OPERATING CONDITIONS	15
4.1.6 EUT TEST CONDITIONS	15
4.1.7 TEST RESULTS	15
4.2 RADIATED EMISSION MEASUREMENT	18
4.2.1 RADIATED EMISSION LIMITS	18
4.2.2 TEST PROCEDURE	19
4.2.3 DEVIATION FROM TEST STANDARD	19
4.2.4 TEST SETUP	20
4.2.5 EUT OPERATING CONDITIONS	21
4.2.6 EUT TEST CONDITIONS	21
4.2.7 TEST RESULTS (BELOW 30MHZ)	22
4.2.8 TEST RESULTS: 30MHZ TO 1000MHZ	23
4.2.9 TEST RESULTS (ABOVE 1000 MHZ)	30
5 . NUMBER OF HOPPING CHANNEL	45
5.1 APPLIED PROCEDURES	45
5.1.1 TEST PROCEDURE	45
5.1.2 DEVIATION FROM STANDARD	45
5.1.3 TEST SETUP	45
5.1.4 EUT OPERATION CONDITIONS	45
5.1.5 EUT TEST CONDITIONS	45



Table of Contents	Page
5.1.6 TEST RESULTS	46
6 . AVERAGE TIME OF OCCUPANCY	47
6.1 APPLIED PROCEDURES / LIMIT	47
6.1.1 TEST PROCEDURE	47
6.1.2 DEVIATION FROM STANDARD	47
6.1.3 TEST SETUP	47
6.1.4 EUT OPERATION CONDITIONS	48
6.1.5 EUT TEST CONDITIONS	48
6.1.6 TEST RESULTS	49
7 . HOPPING CHANNEL SEPARATION MEASUREMENT	61
7.1 APPLIED PROCEDURES / LIMIT	61
7.1.1 TEST PROCEDURE	61
7.1.2 DEVIATION FROM STANDARD	61
7.1.3 TEST SETUP	61
7.1.4 EUT TEST CONDITIONS	61
7.1.5 TEST RESULTS	62
8 . BANDWIDTH TEST	66
8.1 APPLIED PROCEDURES	66
8.1.1 TEST PROCEDURE	66
8.1.2 DEVIATION FROM STANDARD	66
8.1.3 TEST SETUP	66
8.1.4 EUT OPERATION CONDITIONS	66
8.1.5 EUT TEST CONDITIONS	66
8.1.6 TEST RESULTS	67
9 . PEAK OUTPUT POWER TEST	71
9.1 APPLIED PROCEDURES / LIMIT	71
9.1.1 TEST PROCEDURE	71
9.1.2 DEVIATION FROM STANDARD	71
9.1.3 TEST SETUP	71
9.1.4 EUT OPERATION CONDITIONS	71
9.1.5 EUT TEST CONDITIONS	71
9.1.6 TEST RESULTS	72
10 . ANTENNA CONDUCTED SPURIOUS EMISSION	76
10.1 APPLIED PROCEDURES / LIMIT	76
10.1.1 TEST PROCEDURE	76
10.1.2 DEVIATION FROM STANDARD	76
10.1.3 TEST SETUP	77
10.1.4 EUT OPERATION CONDITIONS	77
10.1.5 EUT TEST CONDITIONS	77
10.1.6 TEST RESULTS	78



Table of Contents

Page

11 . MEASUREMENT INSTRUMENTS LIST AND SETTING

88

12 . EUT TEST PHOTO

90



REPORT ISSUED HISTORY

Issued No.	Description	Issued Date
NEI-FICP-1-1402C004	Original Issue.	Mar. 10, 2014



1. CERTIFICATION

Equipment : Tablet
Brand Name : NVIDIA
Model Name : P1988
Applicant : NVIDIA CORPORATION
Manufacturer : NVIDIA CORPORATION
Address : 2701 SAN TOMAS EXPRESSWAY, SANTA CLARA, CALIFORNIA 95050,
UNITED STATES OF AMERICA
Factory : HONGFUJIN PRECISION ELECTRONICS (TIANJIN) CO., LTD
Address : A01, NO.36, North Street, West Zone, Economic & Technological Development
Area, Tianjin
Date of Test : Feb. 10, 2014 ~ Mar. 07, 2014
Test Item : ENGINEERING SAMPLE
Standard(s) : FCC Part15, Subpart C : 2012 (15.247) / ANSI C63.4 : 2009 /
FCC Public Notice DA 00-705, March 30, 2000.
Canada RSS-210:2010
RSS-GEN Issue 3, Dec 2010

The above equipment has been tested and found compliance with the requirement of the relative standards by Neutron Engineering Inc. EMC Laboratory.
The test data, data evaluation, and equipment configuration contained in our test report (Ref No. NEI-FICP-1-1402C004) were obtained utilizing the test procedures, test instruments, test sites that has been accredited by the Authority of TAF according to the ISO-17025 quality assessment standard and technical standard(s).



2. SUMMARY OF TEST RESULTS

Test procedures according to the technical standard(s):

Applied Standard(s): 47 CFR Part 15, Subpart C: 2012; Canada RSS-210:2010; RSS-GEN Issue 3, Dec 2010				
Standard(s) Section		Test Item	Judgment	Remark
FCC	IC			
15.207	RSS-GEN Issue 3, Dec 2010 7.2.4	Conducted Emission	PASS	
15.247(d)	RSS-210, Issue 8, Annex 8, A8.5	Antenna conducted Spurious Emission	PASS	
15.247 (a)(1)	RSS-210, Issue 8, Annex 8, A8.1(b)	Hopping Channel Separation	PASS	
15.247 (b)(1)	RSS-210, Issue 8, Annex 8, A8.1(b)	Peak Output Power	PASS	
15.247(d) 15.209	RSS-210, Issue 8, Annex 8, Section 8.5	Radiated Spurious Emission	PASS	
15.247 (a)(1)(iii)	RSS-210, Issue 8, Annex 8, A8.1(d)	Number of Hopping Frequency	PASS	
15.247 (a)(1)(iii)	RSS-210, Issue 8, Annex 8, A8.1(d)	Dwell Time	PASS	
15.205	RSS-GEN Issue 3, Dec 2010 7.2.2	Restricted Bands	PASS	
15.203	-	Antenna Requirement	PASS	

Note:

- (1) "N/A" denotes test is not applicable in this test report
- (2) According to FCC Public Notice DA 00-705, March 30, 2000.



2.1 TEST FACILITY

The test facilities used to collect the test data in this report is **DG-C02/DG-CB03** at the location of No.3,Jinshagang 1st Road, Shixia, Dalang Town, Dong Guan, China.523792
 Neutron's test firm number for FCC: 319330

2.2 MEASUREMENT UNCERTAINTY

Where relevant, the following measurement uncertainty levels have been estimated for tests performed on the EUT as specified in CISPR 16-4-2:

The reported uncertainty of measurement $y \pm U$, where expanded uncertainty **U** is based on a standard uncertainty multiplied by a coverage factor of **k=2** , providing a level of confidence of approximately **95 %**.

A. Conducted Measurement :

Test Site	Method	Measurement Frequency Range	U , (dB)	Note
DG-C02	CISPR	150 KHz ~ 30MHz	1.94	

B. Radiated Measurement :

Test Site	Method	Measurement Frequency Range	Ant. H / V	U , (dB)	Note
DG-CB03	CISPR	9KHz~30MHz	V	3.79	
		9KHz~30MHz	H	3.57	
		30MHz ~ 200MHz	V	3.82	
		30MHz ~ 200MHz	H	3.60	
		200MHz ~ 1,000MHz	V	3.86	
		200MHz ~ 1,000MHz	H	3.94	
		1GHz~18GHz	V	3.12	
		1GHz~18GHz	H	3.68	
		18GHz~40GHz	V	4.15	
		18GHz~40GHz	H	4.14	



3. GENERAL INFORMATION

3.1 GENERAL DESCRIPTION OF EUT

Equipment	Tablet	
Brand Name	NVIDIA	
Model Name	P1988	
Model Difference	N/A	
Product Description	Operation Frequency	2402~2480 MHz
	Modulation Technology	GFSK(1Mbps) π /4-DQPSK(2Mbps)
	Bit Rate of Transmitter	8-DPSK(3Mbps)
	Output Power (Max.)	0.69 dBm (1Mbps) 2.36 dBm (3Mbps)
Power Source	#1 DC voltage supplied from AC adapter. 1) Brand/ Model: NVIDIA / P2551 2) Brand/ Model: Chicony / W12-010N3A #2 Supplied from lithium-ion battery. 1) Brand/ Model: YOKU/ 32102102 #3 Supplied from USB charging.	
Power Rating	#1 AC adapter 1) I/P: AC 100-240V~, 50-60Hz, 0.3A O/P: DC 5.2V, 2.1A 2) I/P: AC 100-240V~, 50/60Hz, 0.3A O/P: DC 5.35V, 2A #2 Lithium-ion battery 1) DC 3.7V 4100mAh #3 USB charging 1) DC 5V 2A	

Note:

1. For a more detailed features description, please refer to the manufacturer's specifications or the User's Manual.



2.

Channel List					
Channel	Frequency (MHz)	Channel	Frequency (MHz)	Channel	Frequency (MHz)
00	2402	27	2429	54	2456
01	2403	28	2430	55	2457
02	2404	29	2431	56	2458
03	2405	30	2432	57	2459
04	2406	31	2433	58	2460
05	2407	32	2434	59	2461
06	2408	33	2435	60	2462
07	2409	34	2436	61	2463
08	2410	35	2437	62	2464
09	2411	36	2438	63	2465
10	2412	37	2439	64	2466
11	2413	38	2440	65	2467
12	2414	39	2441	66	2468
13	2415	40	2442	67	2469
14	2416	41	2443	68	2470
15	2417	42	2444	69	2471
16	2418	43	2445	70	2472
17	2419	44	2446	71	2473
18	2420	45	2447	72	2474
19	2421	46	2448	73	2475
20	2422	47	2449	74	2476
21	2423	48	2450	75	2477
22	2424	49	2451	76	2478
23	2425	50	2452	77	2479
24	2426	51	2453	78	2480
25	2427	52	2454		
26	2428	53	2455		

3 Table for Filed Antenna

Ant.	Brand	Model Name	Antenna Type	Connector	Gain (dBi)
1	SPEED	G-KW-0002	Monopole	N/A	6.3



3.2 DESCRIPTION OF TEST MODES

To investigate the maximum EMI emission characteristics generated from EUT, the test system was pre-scanning tested based on the consideration of following EUT operation mode or test configuration mode which possibly have effect on EMI emission level. Each of these EUT operation mode(s) or test configuration mode(s) mentioned above was evaluated respectively.

Pretest Mode	Description
Mode 1	TX Mode Note (1)
Mode 2	Bluetooth

The EUT system operated these modes were found to be the worst case during the pre-scanning test as following:

For Conducted Emission	
Final Test Mode	Description
Mode 2	Bluetooth

For Radiated Emission	
Final Test Mode	Description
Mode 1	TX Mode Note (1)

Note:

- (1) The measurements are performed at the high, middle, low available channels.
- (2) The measurements for Hopping Channel Separation, Bandwidth and Peak Output Power were tested during 1Mbps, 2Mbps and 3Mbps, the worst case are 1Mbps and 3Mbps, only worst case was documented.
- (3) The EUT was pre-tested on positioned of each 3 axis. The worst case was found positioned on X-plane. Therefore only the test data of this X-plane was used for radiated emission measurement test.
- (4) The EUT system operated in these modes (AC adapter and Lithium-ion battery) and AC adapter found to be the worst case during the pre-scanning test.

3.3 TABLE OF PARAMETERS OF TEST SOFTWARE SETTING

During testing, channel & power controlling software provided by the customer was used to control the operating channel as well as the output power level. The RF output power selection is for the setting of RF output power expected by the customer and is going to be fixed on the firmware of the final end product power parameters of FHSS

Test software version	Bluetest		
	2402 MHz	2441 MHz	2480 MHz
Frequency			
Parameters-1Mbps	7	7	7
Parameters-3Mbps	7	7	7



3.4 BLOCK DIAGRAM SHOWING THE CONFIGURATION OF SYSTEM TESTED

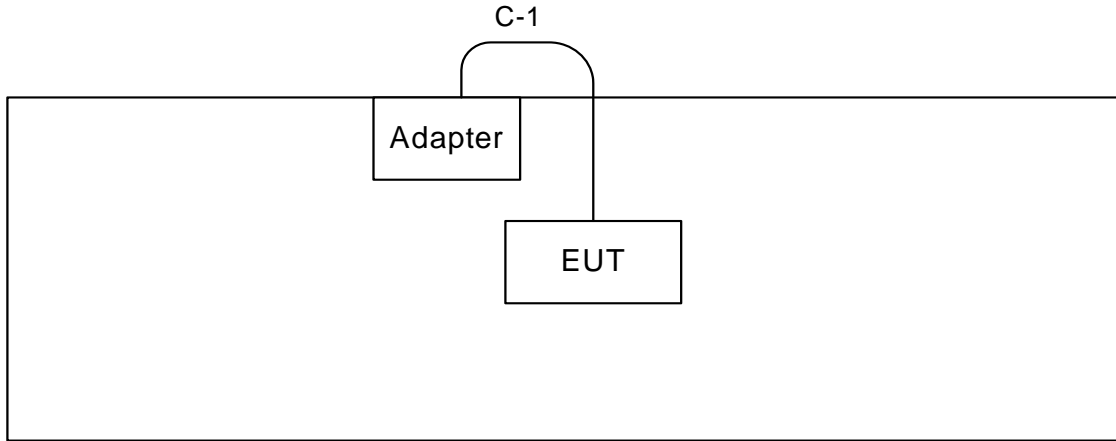

3.5 DESCRIPTION OF SUPPORT UNITS

The EUT has been tested as an independent unit together with other necessary accessories or support units. The following support units or accessories were used to form a representative test configuration during the tests.

Item	Equipment	Mfr/Brand	Model/Type No.	FCC ID/IC	Series No.	Note
-	-	-	-	-	-	

Item	Shielded Type	Ferrite Core	Length	Note
C-1	YES	NO	0.8m	USB Cable



4. EMC EMISSION TEST

4.1 CONDUCTED EMISSION MEASUREMENT

4.1.1 POWER LINE CONDUCTED EMISSION Limits (Frequency Range 150KHz-30MHz)

Frequency (MHz)	Class A (dBuV)		Class B (dBuV)		Standard
	Quasi-peak	Average	Quasi-peak	Average	
0.15 -0.5	79.00	66.00	66 - 56 *	56 - 46 *	CISPR
0.50 -5.0	73.00	60.00	56.00	46.00	CISPR
5.0 -30.0	73.00	60.00	60.00	50.00	CISPR
0.15 -0.5	79.00	66.00	66 - 56 *	56 - 46 *	FCC
0.50 -5.0	73.00	60.00	56.00	46.00	FCC
5.0 -30.0	73.00	60.00	60.00	50.00	FCC

Note:

- (1) The tighter limit applies at the band edges.
- (2) The limit of " * " marked band means the limitation decreases linearly with the logarithm of the frequency in the range.

The following table is the setting of the receiver

Receiver Parameters	Setting
Attenuation	10 dB
Start Frequency	0.15 MHz
Stop Frequency	30 MHz
IF Bandwidth	9 KHz

4.1.2 TEST PROCEDURE

- a. The EUT was placed 0.8 meters from the horizontal ground plane with EUT being connected to the power mains through a line impedance stabilization network (LISN). All other support equipments powered from additional LISN(s). The LISN provide 50 Ohm/ 50uH of coupling impedance for the measuring instrument.
- b. Interconnecting cables that hang closer than 40 cm to the ground plane shall be folded back and forth in the center forming a bundle 30 to 40 cm long.
- c. I/O cables that are not connected to a peripheral shall be bundled in the center. The end of the cable may be terminated, if required, using the correct terminating impedance. The overall length shall not exceed 1 m.
- d. LISN at least 80 cm from nearest part of EUT chassis.
- e. For the actual test configuration, please refer to the related Item –EUT Test Photos.

4.1.3 DEVIATION FROM TEST STANDARD

No deviation

4.1.4 TEST SETUP

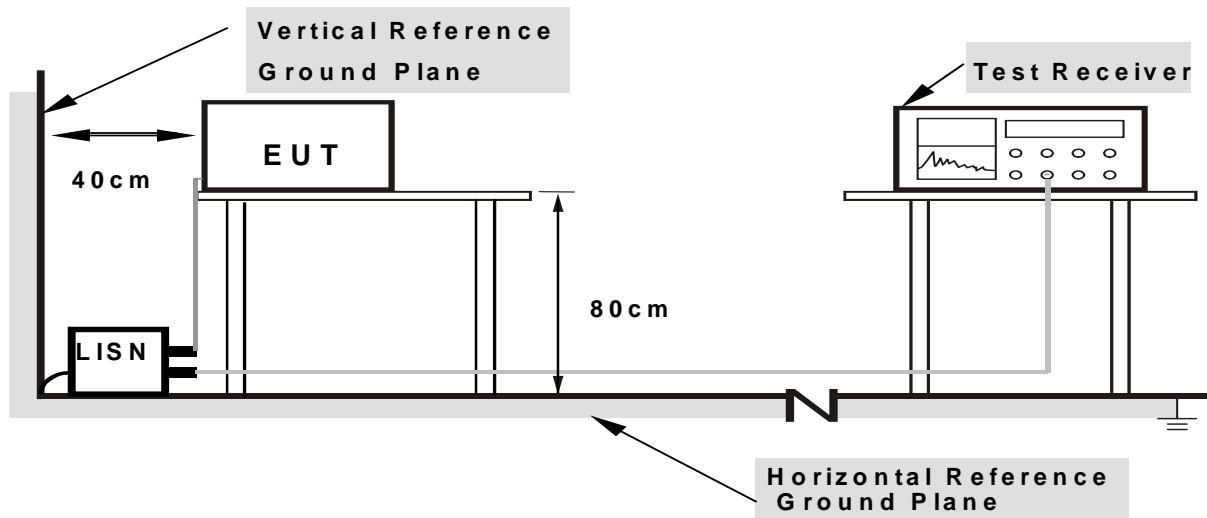

Note: 1. Support units were connected to second LISN.

2. Both of LISNs (AMN) are 80 cm from EUT and at least 80 cm from other units and other metal planes

4.1.5 EUT OPERATING CONDITIONS

The EUT was configured for testing in a typical function (as a customer would normally use it), EUT was programmed to be in continuously transmitting/receiving data or hopping on mode.

4.1.6 EUT TEST CONDITIONS

Temperature: 25°C

Relative Humidity: 55%

Test Voltage: 120V/60Hz

4.1.7 TEST RESULTS

Remark:

- (1) All readings are QP Mode value unless otherwise stated AVG in column of 'Note'. If the QP Mode Measured value compliance with the QP Limits and lower than AVG Limits, the EUT shall be deemed to meet both QP & AVG Limits and then only QP Mode was measured, but AVG Mode didn't perform in this case, a "*" marked in AVG Mode column of Interference Voltage Measured.
- (2) Measuring frequency range from 150KHz to 30MHz.



Test Mode: Bluetooth (Adapter: P2551)

Line

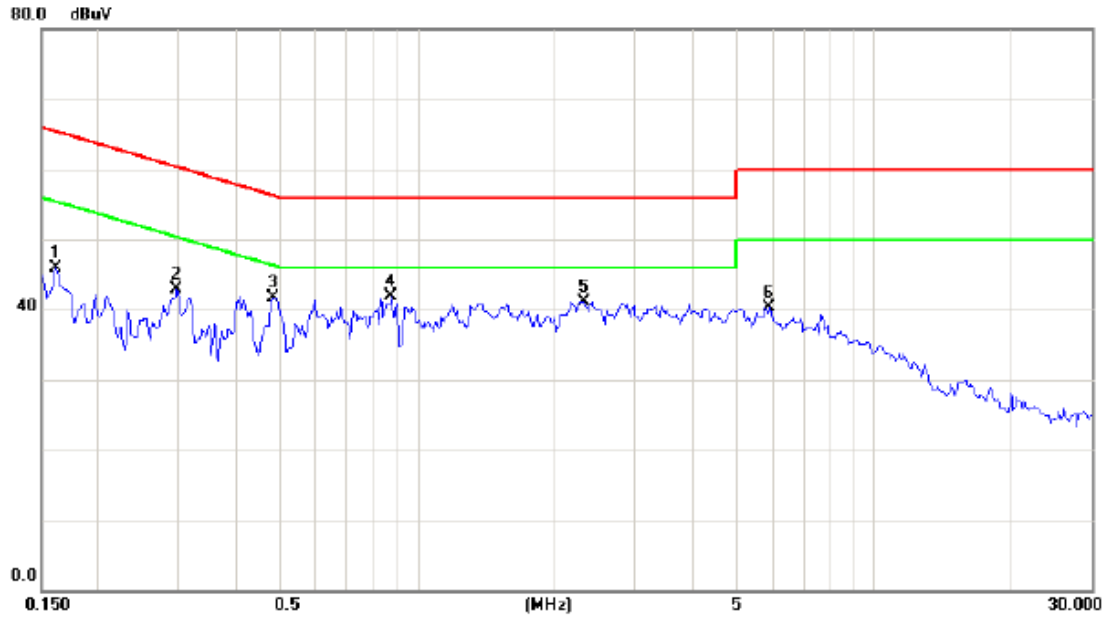

No.	Mk.	Freq. MHz	Reading Level dBuV	Correct Factor dB	Measure- ment dBuV	Limit dBuV	Over dB	Detector	Comment
1		0.1617	36.41	9.52	45.93	65.38	-19.45	peak	
2		0.2983	33.32	9.54	42.86	60.29	-17.43	peak	
3		0.4860	32.22	9.55	41.77	56.24	-14.47	peak	
4	*	0.8765	32.28	9.57	41.85	56.00	-14.15	peak	
5		2.3180	31.53	9.59	41.12	56.00	-14.88	peak	
6		5.9257	30.70	9.64	40.34	60.00	-19.66	peak	



Test Mode: Bluetooth (Adapter: P2551)

Neutral

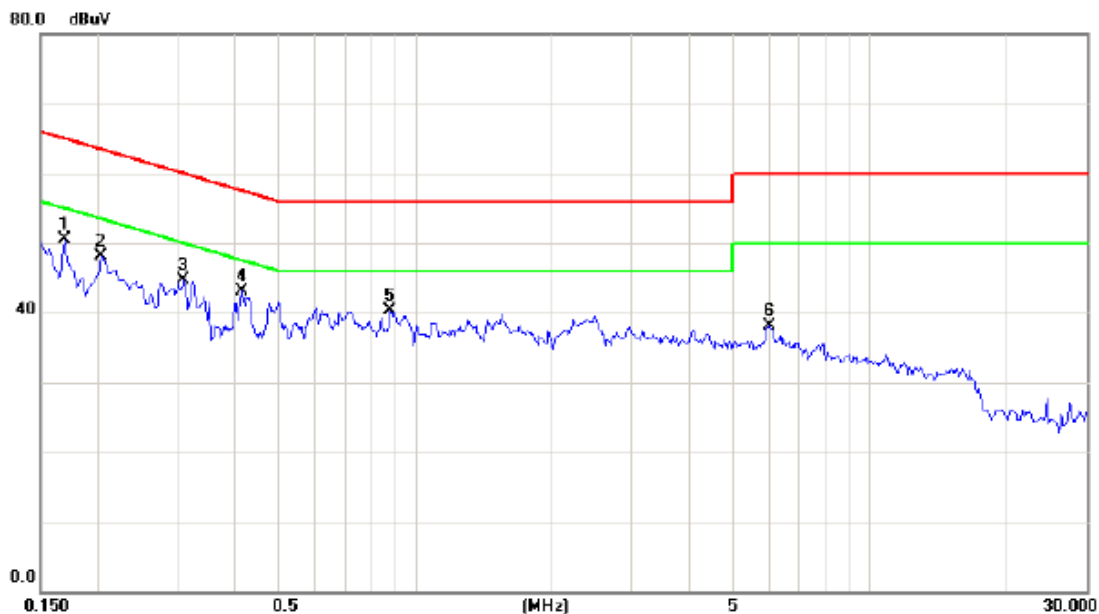

No.	Mk.	Freq. MHz	Reading Level dBuV	Correct Factor dB	Measure- ment dBuV	Limit dBuV	Over dB	Detector	Comment
1		0.1695	40.83	9.59	50.42	64.98	-14.56	peak	
2		0.2046	38.57	9.59	48.16	63.42	-15.26	peak	
3		0.3100	35.17	9.59	44.76	59.97	-15.21	peak	
4	*	0.4156	33.59	9.59	43.18	57.54	-14.36	peak	
5		0.8802	30.73	9.60	40.33	56.00	-15.67	peak	
6		5.9960	28.34	9.67	38.01	60.00	-21.99	peak	



4.2 RADIATED EMISSION MEASUREMENT

4.2.1 RADIATED EMISSION LIMITS (Frequency Range 9KHz -1000MHz)

20dB in any 100 KHz bandwidth outside the operating frequency band. In case the emission fall within the restricted band specified on 15.205(a), then the 15.209(a) limit in the table below has to be followed.

Frequency (MHz)	Field Strength (microvolts/meter)	Measurement Distance (meters)
0.009~0.490	2400/F(KHz)	300
0.490~1.705	24000/F(KHz)	30
1.705~30.0	30	30
30~88	100	3
88~216	150	3
216~960	200	3
960~1000	500	3

LIMITS OF RADIATED EMISSION MEASUREMENT (Above 1000MHz)

Frequency (MHz)	dB(uV/m) (at 3 meters)	
	Peak	Average
Above 1000	74	54

Notes:

- (1) The limit for radiated test was performed according to FCC PART 15C.
- (2) The tighter limit applies at the band edges.
- (3) Emission level (dBuV/m) =20log Emission level (uV/m).

Spectrum Parameter	Setting
Attenuation	Auto
Start Frequency	1000 MHz
Stop Frequency	10th carrier harmonic
RBW / VBW (emission in restricted band)	1 MHz / 1 MHz for Peak, 1 MHz / 10Hz for Average

Spectrum Receiver Parameter	Setting
Attenuation	Auto
Start ~ Stop Frequency	9KHz ~90KHz for PK/AVG detector
Start ~ Stop Frequency	90KHz ~110KHz for QP detector
Start ~ Stop Frequency	110KHz ~490KHz for PK/AVG detector
Start ~ Stop Frequency	490KHz ~30MHz for QP detector
Start ~ Stop Frequency	30MHz~1000MHz for QP detector



4.2.2 TEST PROCEDURE

- a. The EUT was placed on the top of a rotating table 0.8 meters above the ground at a 3 meter semi-anechoic chamber. The table was rotated 360 degrees to determine the position of the highest radiation.(below 1GHz)
- b. The EUT was placed on the top of a rotating table 0.8 meters above the ground at a 3 meter semi-anechoic chamber. The table was rotated 360 degrees to determine the position of the highest radiation.(above 1GHz)
- c. The height of the equipment or of the substitution antenna shall be 0.8 m; the height of the test antenna shall vary between 1 m to 4 m. Both horizontal and vertical polarizations of the antenna are set to make the measurement.
- d. The initial step in collecting conducted emission data is a spectrum analyzer peak detector mode pre-scanning the measurement frequency range. Significant peaks are then marked and then Quasi Peak detector mode re-measured.
- e. If the Peak Mode measured value compliance with and lower than Quasi Peak Mode Limit, the EUT shall be deemed to meet QP Limits and then no additional QP Mode measurement performed.
- f. For the actual test configuration, please refer to the related Item –EUT Test Photos.

4.2.3 DEVIATION FROM TEST STANDARD

No deviation

4.2.4 TEST SETUP

(A) Radiated Emission Test Set-Up Frequency Below 1 GHz

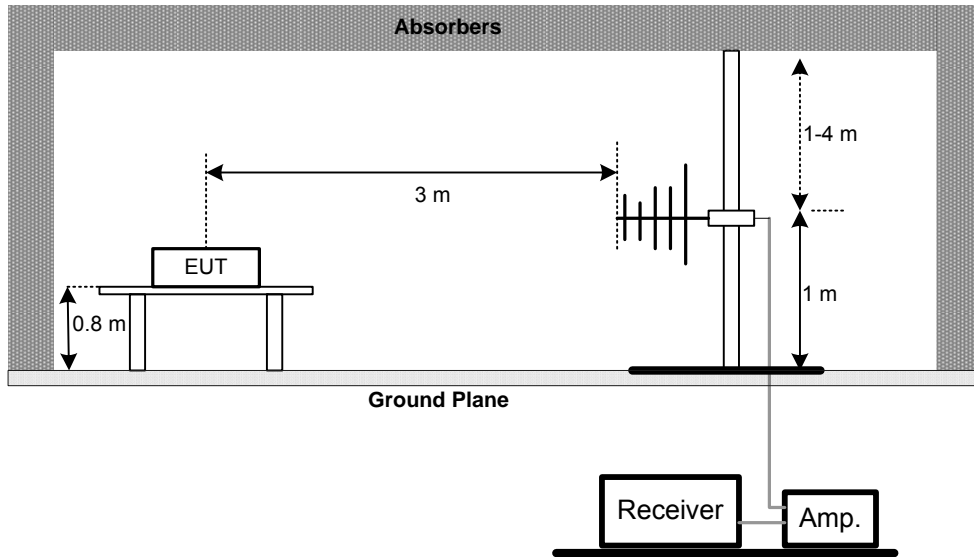

(B) Radiated Emission Test Set-Up Frequency Above 1 GHz

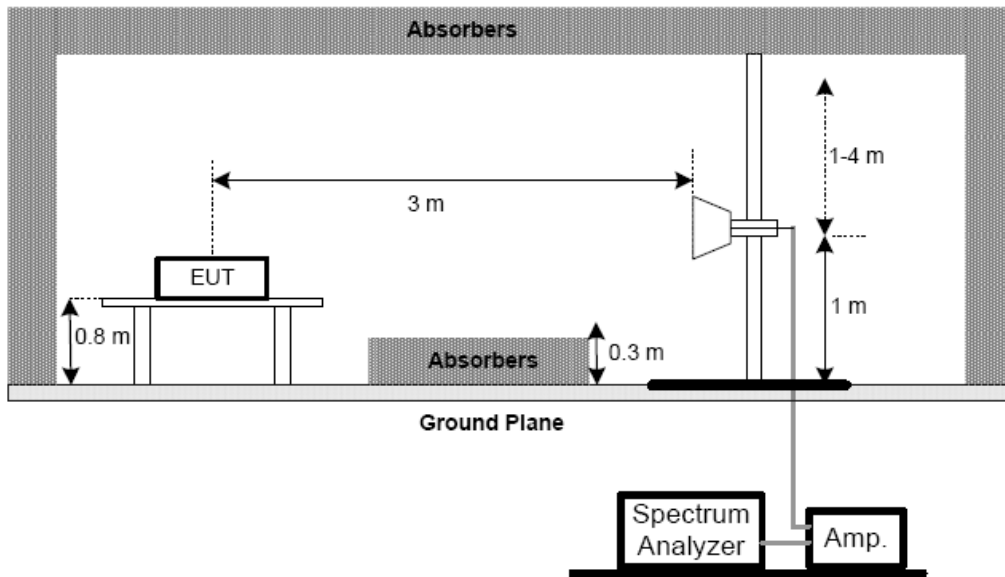

Note: The antenna can be moved between 1 to 4 meters above the ground.

(C) For radiated emissions below 30MHz

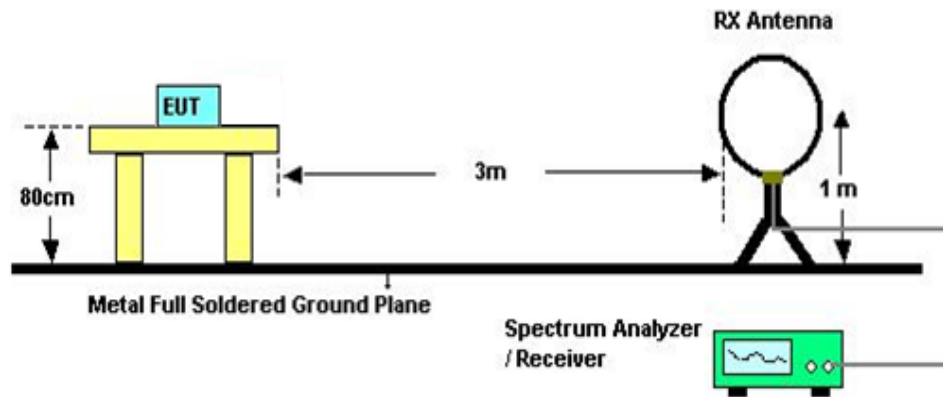

4.2.5 EUT OPERATING CONDITIONS

The EUT tested system was configured as the statements of 4.1.5 Unless otherwise a special operating condition is specified in the follows during the testing

4.2.6 EUT TEST CONDITIONS

Temperature: 25°C

Relative Humidity: 55%

Test Voltage: 120V/60Hz



4.2.7 TEST RESULTS (BELOW 30MHZ)

Test Mode:	TX 2402MHz (Adapter: P2551)
------------	-----------------------------

Freq. (MHz)	Ant. 0°/90°	Reading(RA) (dBuV)	Corr.Factor(CF) (dB)	Measured(FS) (dBuV/m)	Limits(QP) (dBuV/m)	Margin (dB)	Note
0.0213	0°	16.52	24.22	40.74	121.04	-80.30	AV
0.0213	0°	18.19	24.22	42.41	141.04	-98.63	PK
0.0279	0°	17.15	23.80	40.95	118.69	-77.74	AV
0.0279	0°	19.03	23.80	42.83	138.69	-95.86	PK
0.0331	0°	17.16	23.47	40.63	117.21	-76.58	AV
0.0331	0°	20.08	23.47	43.55	137.21	-93.66	PK
0.0528	0°	18.47	22.34	40.81	113.15	-72.34	AV
0.0528	0°	21.55	22.34	43.89	133.15	-89.26	PK
0.3170	0°	18.36	20.24	38.60	97.58	-58.98	AVG
0.3170	0°	21.05	20.24	41.29	117.58	-76.29	PK
1.5250	0°	18.73	19.55	38.28	63.94	-25.66	QP

Freq. (MHz)	Ant. 0°/90°	Reading(RA) (dBuV)	Corr.Factor(CF) (dB)	Measured(FS) (dBuV/m)	Limits(QP) (dBuV/m)	Margin (dB)	Note
0.0174	90°	17.49	24.30	41.79	122.79	-81.00	AVG
0.0174	90°	19.21	24.30	43.51	142.79	-99.28	PK
0.0268	90°	16.93	23.87	40.80	119.04	-78.24	AVG
0.0268	90°	18.31	23.87	42.18	139.04	-96.86	PK
0.0379	90°	20.01	23.17	43.18	116.03	-72.86	AVG
0.0379	90°	21.65	23.17	44.82	136.03	-91.22	PK
0.0517	90°	20.22	22.37	42.59	113.33	-70.75	AVG
0.0517	90°	23.36	22.37	45.73	133.33	-87.61	PK
0.3260	90°	18.43	20.22	38.65	97.34	-58.69	AVG
0.3260	90°	20.71	20.22	40.93	117.34	-76.41	PK
1.6730	90°	18.62	19.53	38.15	63.13	-24.98	QP

Remark:

- (1) The amplitude of spurious emissions which are attenuated by more than 20 dB below the permissible value has no need to be reported.
- (2) Distance extrapolation factor = 40 log (specific distance / test distance) (dB).
- (3) Limit line = specific limits (dBuV) + distance extrapolation factor.



4.2.8 TEST RESULTS: 30MHZ TO 1000MHZ

Remark:

- (1) Reading in which marked as QP or Peak means measurements by using are Quasi-Peak Mode or Peak Mode with Detector BW=120KHz ; SPA setting in RBW=120KHz, VBW =120KHz, Swp. Time = 0.3 sec./MHz.
- (2) All readings are Peak unless otherwise stated QP in column of 『Note』 . Peak denotes that the Peak reading compliance with the QP Limits and then QP Mode measurement didn't perform.
- (3) Measuring frequency range from 30MHz to 1000MHz.
- (4) If the peak scan value lower limit more than 20dB, then this signal data does not show in table.



Test Mode: TX 2402MHz _CH00_1Mbps (Adapter: P2551)

Vertical

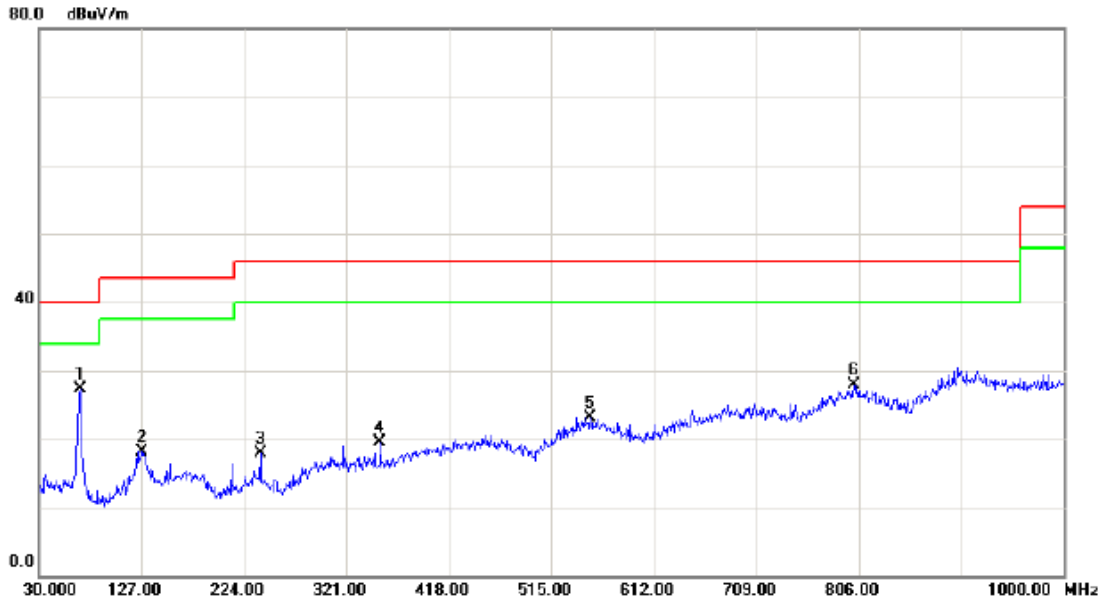

No.	Mk.	Freq. MHz	Reading Level dBuV	Correct Factor dB	Measure- ment dBuV/m	Limit dBuV/m	Over dB	Detector	Comment
1	*	68.8000	42.88	-15.57	27.31	40.00	-12.69	peak	
2		127.0000	32.05	-13.85	18.20	43.50	-25.30	peak	
3		239.5200	32.47	-14.62	17.85	46.00	-28.15	peak	
4		353.0100	30.79	-11.27	19.52	46.00	-26.48	peak	
5		551.8600	29.08	-5.94	23.14	46.00	-22.86	peak	
6		801.1500	29.57	-1.67	27.90	46.00	-18.10	peak	



Test Mode: TX 2402MHz _CH00_1Mbps (Adapter: P2551)

Horizontal

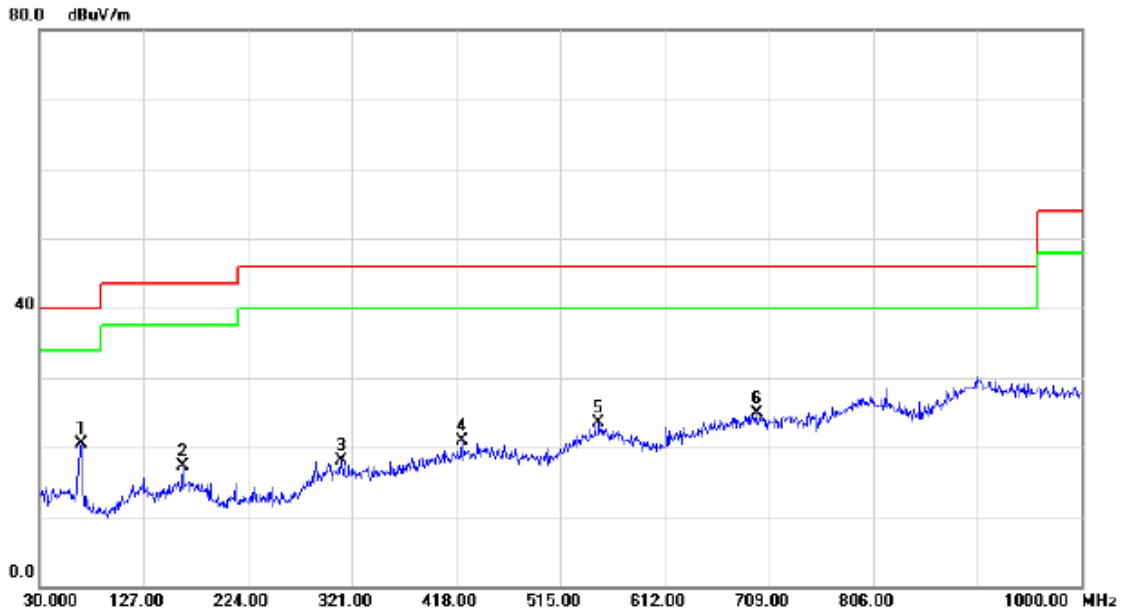

No.	Mk.	Freq. MHz	Reading Level dBuV	Correct Factor dB	Measure- ment dBuV/m	Limit dBuV/m	Over dB	Detector	Comment
1	*	68.8000	36.13	-15.57	20.56	40.00	-19.44	peak	
2		163.8600	30.03	-12.78	17.25	43.50	-26.25	peak	
3		311.3000	29.15	-11.05	18.10	46.00	-27.90	peak	
4		423.8200	30.24	-9.27	20.97	46.00	-25.03	peak	
5		550.8900	29.39	-5.89	23.50	46.00	-22.50	peak	
6		697.3600	29.36	-4.49	24.87	46.00	-21.13	peak	



Test Mode: TX 2441MHz _CH39_1Mbps (Adapter: P2551)

Vertical

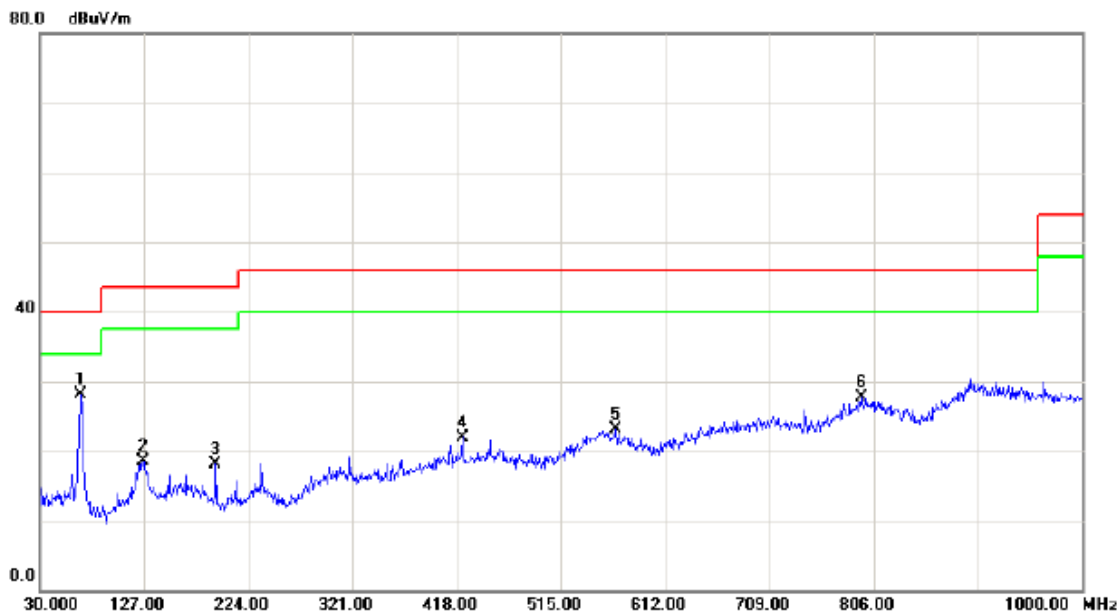

No.	Mk.	Freq. MHz	Reading Level dBuV	Correct Factor dB	Measure- ment dBuV/m	Limit dBuV/m	Over dB	Detector	Comment
1	*	67.8300	43.52	-15.46	28.06	40.00	-11.94	peak	
2		126.0300	32.33	-13.86	18.47	43.50	-25.03	peak	
3		193.9300	33.05	-15.00	18.05	43.50	-25.45	peak	
4		423.8200	31.27	-9.27	22.00	46.00	-24.00	peak	
5		566.4100	29.73	-6.62	23.11	46.00	-22.89	peak	
6		794.3600	29.80	-2.02	27.78	46.00	-18.22	peak	



Test Mode: TX 2441MHz _CH39_1Mbps (Adapter: P2551)

Horizontal

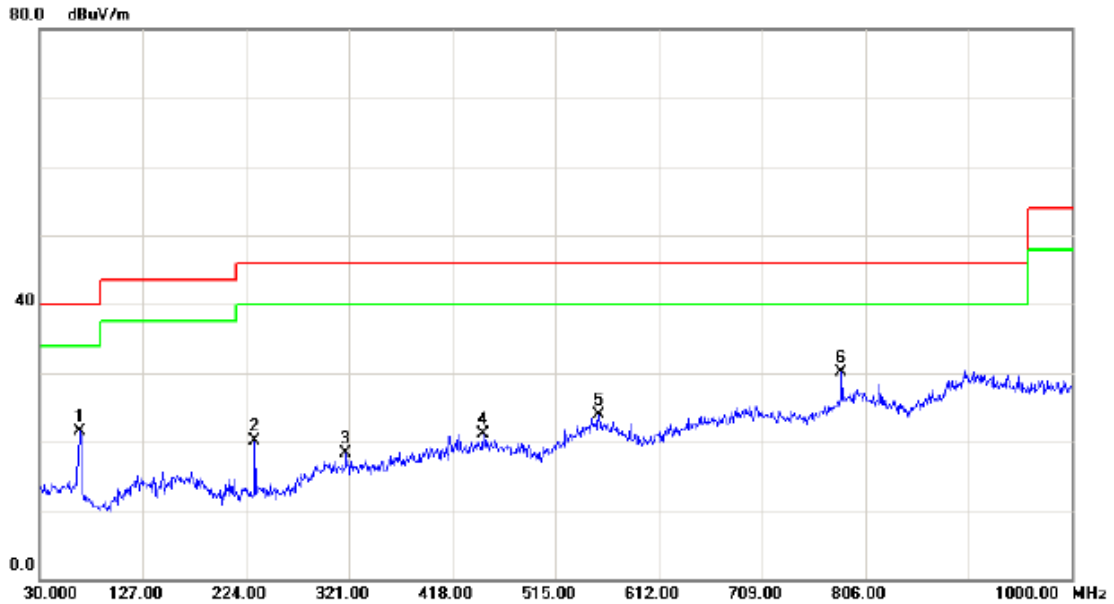

No.	Mk.	Freq. MHz	Reading Level dBuV	Correct Factor dB	Measure- ment dBuV/m	Limit dBuV/m	Over dB	Detector	Comment
1		67.8300	36.92	-15.46	21.46	40.00	-18.54	peak	
2		232.7300	34.70	-14.66	20.04	46.00	-25.96	peak	
3		318.0900	29.40	-11.10	18.30	46.00	-27.70	peak	
4		447.1000	29.93	-8.78	21.15	46.00	-24.85	peak	
5		555.7400	29.95	-6.12	23.83	46.00	-22.17	peak	
6	*	783.6900	32.93	-2.81	30.12	46.00	-15.88	peak	



Test Mode: TX 2480MHz _CH78_1Mbps (Adapter: P2551)

Vertical

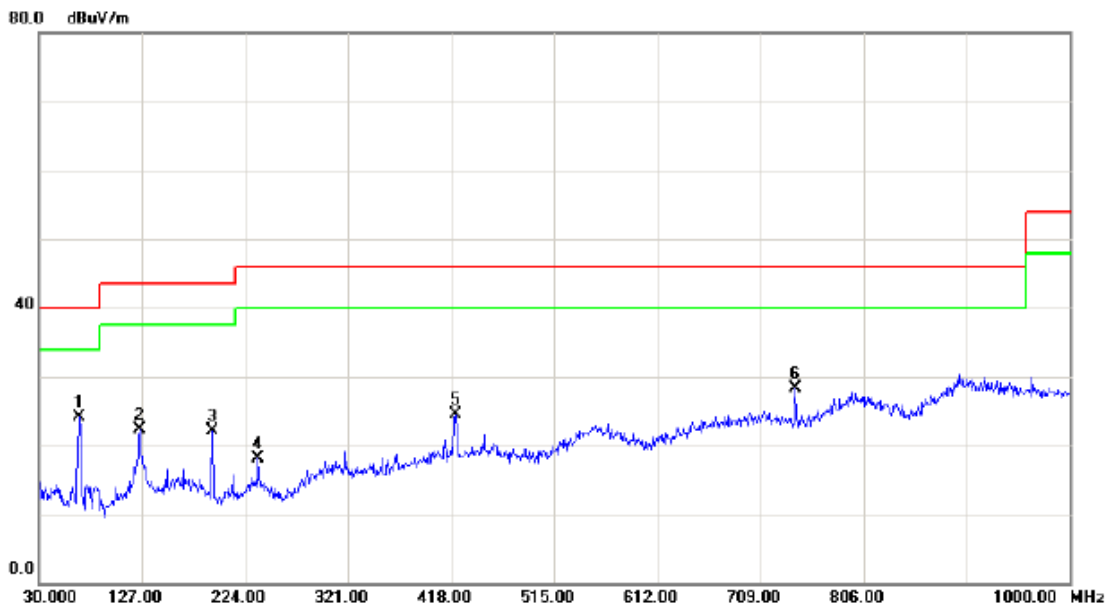

No.	Mk.	Freq. MHz	Reading Level dBuV	Correct Factor dB	Measure- ment dBuV/m	Limit dBuV/m	Over dB	Detector	Comment
1	*	67.8300	39.52	-15.46	24.06	40.00	-15.94	peak	
2		125.0600	36.12	-13.86	22.26	43.50	-21.24	peak	
3		193.9300	37.05	-15.00	22.05	43.50	-21.45	peak	
4		236.6100	32.68	-14.64	18.04	46.00	-27.96	peak	
5		421.8800	33.80	-9.31	24.49	46.00	-21.51	peak	
6		741.9800	33.47	-5.16	28.31	46.00	-17.69	peak	



Test Mode: TX 2480MHz _CH78_1Mbps (Adapter: P2551)

Horizontal

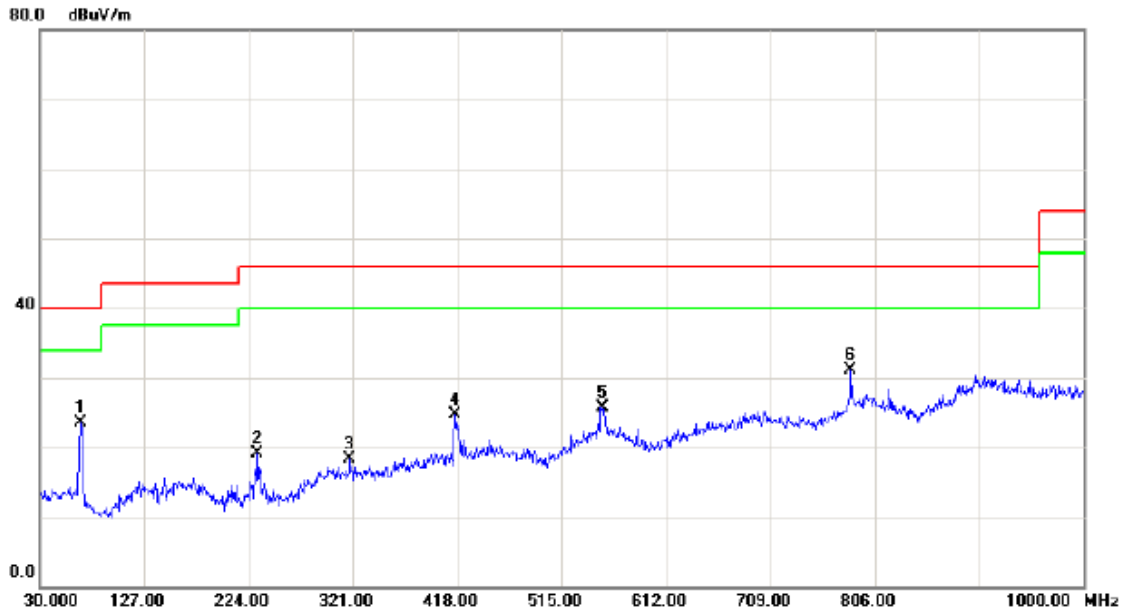

No.	Mk.	Freq. MHz	Reading Level dBuV	Correct Factor dB	Measure- ment dBuV/m	Limit dBuV/m	Over dB	Detector	Comment
1		67.8300	38.92	-15.46	23.46	40.00	-16.54	peak	
2		232.7300	33.70	-14.66	19.04	46.00	-26.96	peak	
3		318.0900	29.40	-11.10	18.30	46.00	-27.70	peak	
4		416.0600	34.09	-9.43	24.66	46.00	-21.34	peak	
5		552.8300	31.71	-5.97	25.74	46.00	-20.26	peak	
6	*	783.6900	33.93	-2.81	31.12	46.00	-14.88	peak	



4.2.9 TEST RESULTS (ABOVE 1000 MHZ)

Remark:

- (1) All readings are Peak unless otherwise stated QP in column of 『Note』 . Peak denotes that the Peak reading compliance with the QP Limits and then QP Mode measurement didn't perform.
- (2) Measuring frequency range from 30MHz to 1000MHz or the 10th harmonic of highest fundamental frequency. "F" denotes fundamental frequency;"H" denotes spurious frequency. "E" denotes band edge frequency. (This judgment method includes the Band Edge Requirement.)
- (3) Radiated emissions measured in frequency range above 1000MHz were made with an instrument using Peak detector mode and AV detector mode of the emission
- (4) Data of measurement within this frequency range shown "*" in the table above means the reading of emissions are attenuated more than 20dB below the permissible limits or the field strength is too small to be measured.
- (5) A preamp and high pass filter were used for this test in order to provide sufficient measurement sensitivity.
- (6) EUT Orthogonal Axis:
"X" - denotes Laid on Table ; "Y" - denotes Vertical Stand ; "Z" - denotes Side Stand
- (7) During the measurements above 1 GHz it is taken care of that the EUT is always within the 3 dB cone of radiation BW of the used antenna



Test Mode: TX 2402MHz_CH00_1Mbps

Freq. (MHz)	Ant.Pol. H/V	Reading		Ant./CF CF(dB)	Act.		Limit		Note
		Peak (dBuV)	AV (dBuV)		Peak (dBuV/m)	AV (dBuV/m)	Peak (dBuV/m)	AV (dBuV/m)	
2390.00	V	22.58	12.98	34.09	56.67	47.07	74.00	54.00	X/E
2402.00	V	63.32	53.57	34.12	97.44	87.69			X/F
4803.95	V	37.89	29.39	6.38	44.27	35.77	74.00	54.00	X/H

Freq. (MHz)	Ant.Pol. H/V	Reading		Ant./CF CF(dB)	Act.		Limit		Note
		Peak (dBuV)	AV (dBuV)		Peak (dBuV/m)	AV (dBuV/m)	Peak (dBuV/m)	AV (dBuV/m)	
2390.00	H	24.02	13.01	34.09	58.11	47.10	74.00	54.00	X/E
2402.00	H	62.55	52.86	34.12	96.67	86.98			X/F
4804.05	H	37.58	29.38	6.38	43.96	35.76	74.00	54.00	X/H

Test Mode: TX 2441MHz_CH39_1Mbps

Freq. (MHz)	Ant.Pol. H/V	Reading		Ant./CF CF(dB)	Act.		Limit		Note
		Peak (dBuV)	AV (dBuV)		Peak (dBuV/m)	AV (dBuV/m)	Peak (dBuV/m)	AV (dBuV/m)	
2441.00	V	64.54	54.75	34.25	98.79	89.00			X/F
4882.69	V	37.12	29.04	6.61	43.73	35.65	74.00	54.00	X/H

Freq. (MHz)	Ant.Pol. H/V	Reading		Ant./CF CF(dB)	Act.		Limit		Note
		Peak (dBuV)	AV (dBuV)		Peak (dBuV/m)	AV (dBuV/m)	Peak (dBuV/m)	AV (dBuV/m)	
2441.00	H	63.31	53.59	34.25	97.56	87.84			X/F
4882.69	H	37.41	29.29	6.61	44.02	35.90	74.00	54.00	X/H

Test Mode: TX 2480MHz_CH78_1Mbps

Freq. (MHz)	Ant.Pol. H/V	Reading		Ant./CF CF(dB)	Act.		Limit		Note
		Peak (dBuV)	AV (dBuV)		Peak (dBuV/m)	AV (dBuV/m)	Peak (dBuV/m)	AV (dBuV/m)	
2479.85	V	65.28	55.38	34.36	99.64	89.74			X/F
2483.50	V	23.02	13.06	34.37	57.39	47.43	74.00	54.00	X/E
4960.52	V	36.81	28.69	6.83	43.64	35.52	74.00	54.00	X/H

Freq. (MHz)	Ant.Pol. H/V	Reading		Ant./CF CF(dB)	Act.		Limit		Note
		Peak (dBuV)	AV (dBuV)		Peak (dBuV/m)	AV (dBuV/m)	Peak (dBuV/m)	AV (dBuV/m)	
2479.85	H	62.54	52.75	34.36	96.90	87.11			X/F
2483.50	H	23.91	13.06	34.37	58.28	47.43	74.00	54.00	X/E
4960.52	H	36.64	28.67	6.83	43.47	35.50	74.00	54.00	X/H



TX CH00(Above 1000 MHz, Vertical)

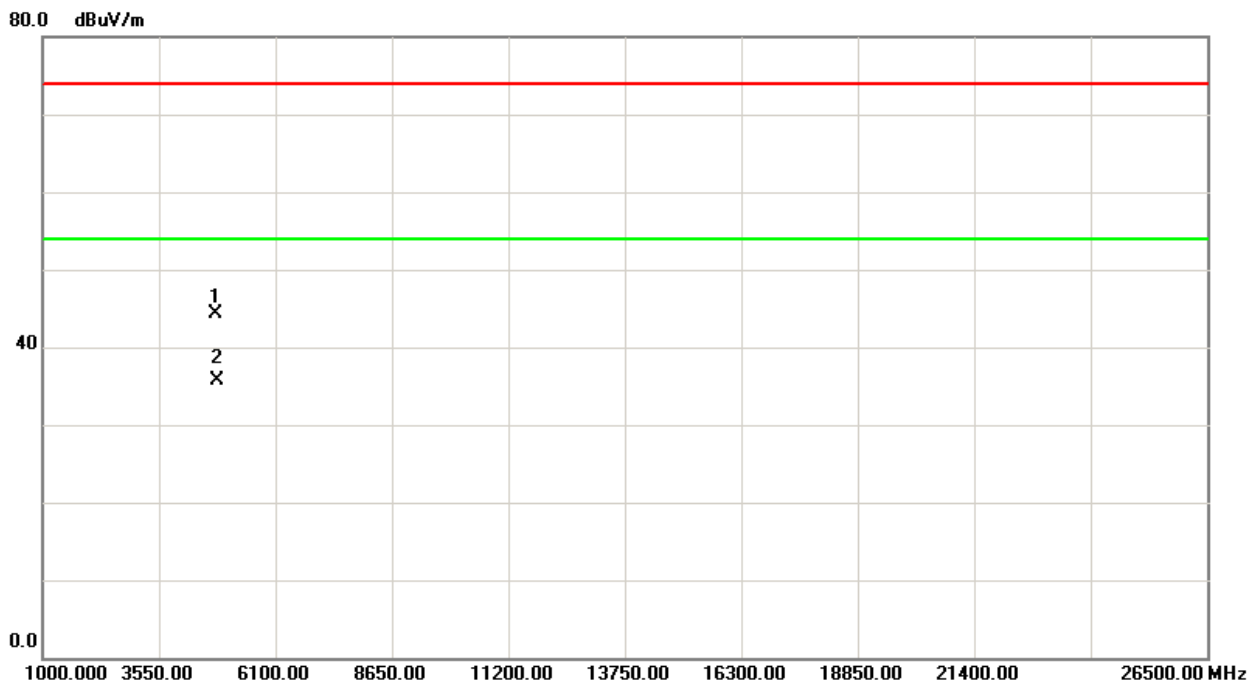
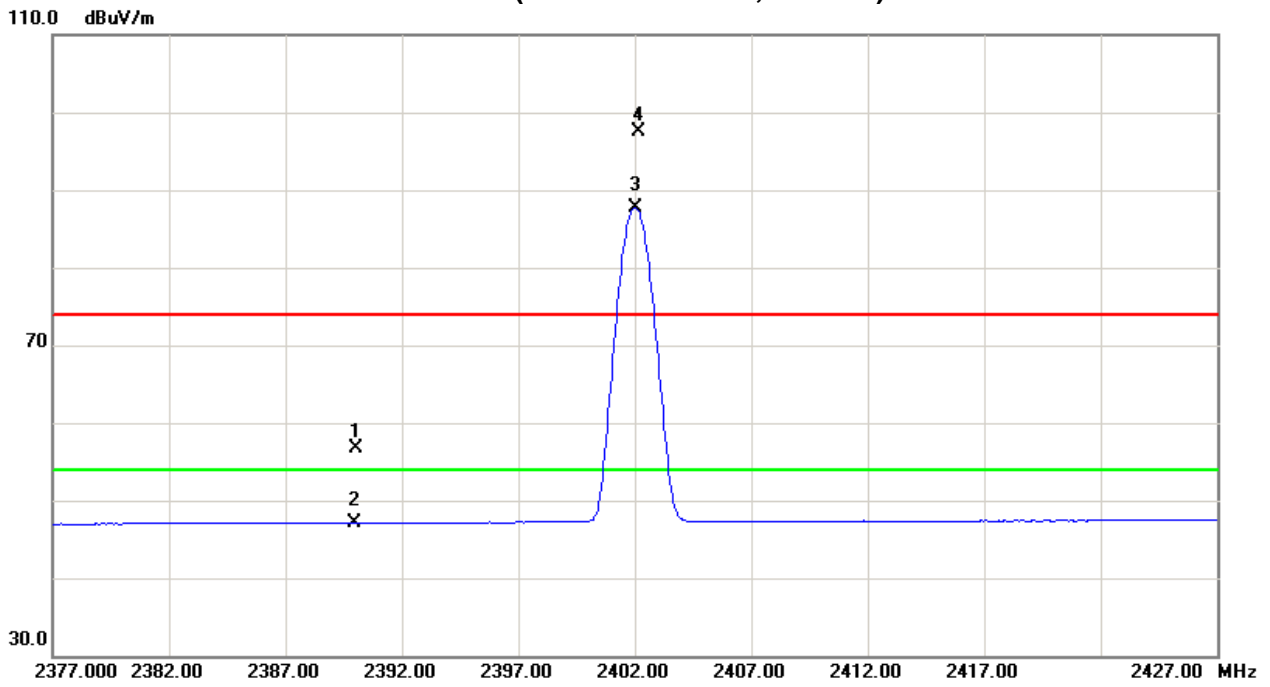



TX CH00(Above 1000 MHz, Horizontal)

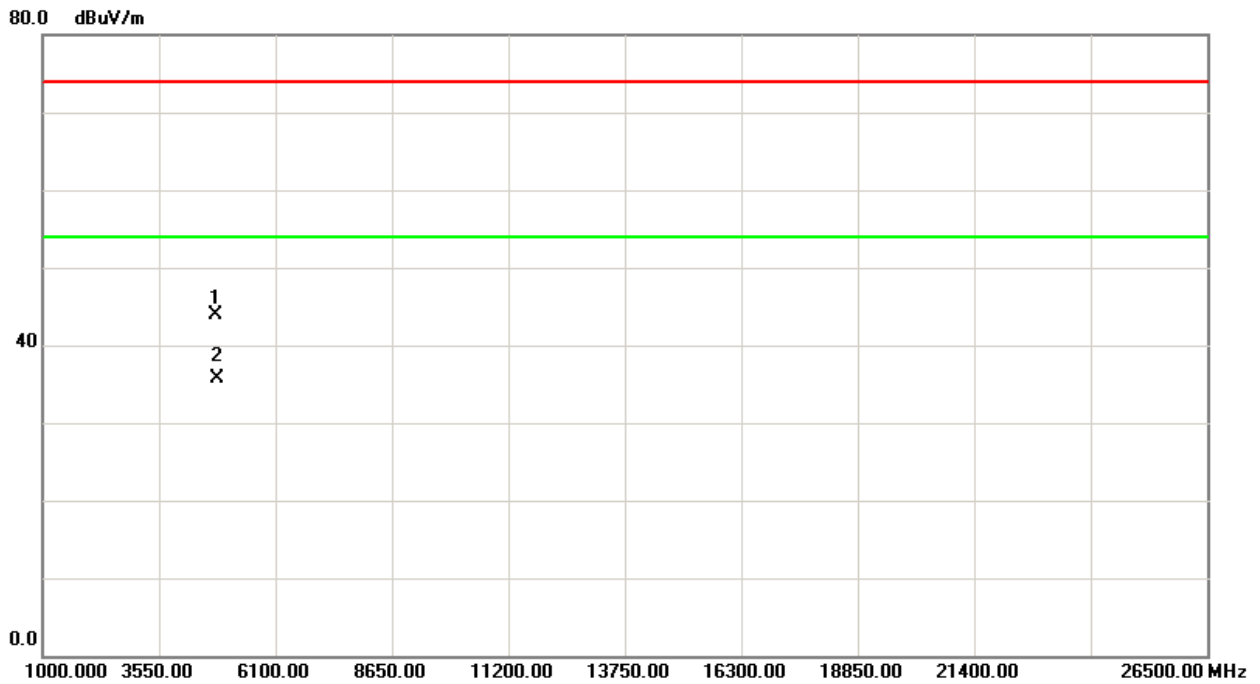
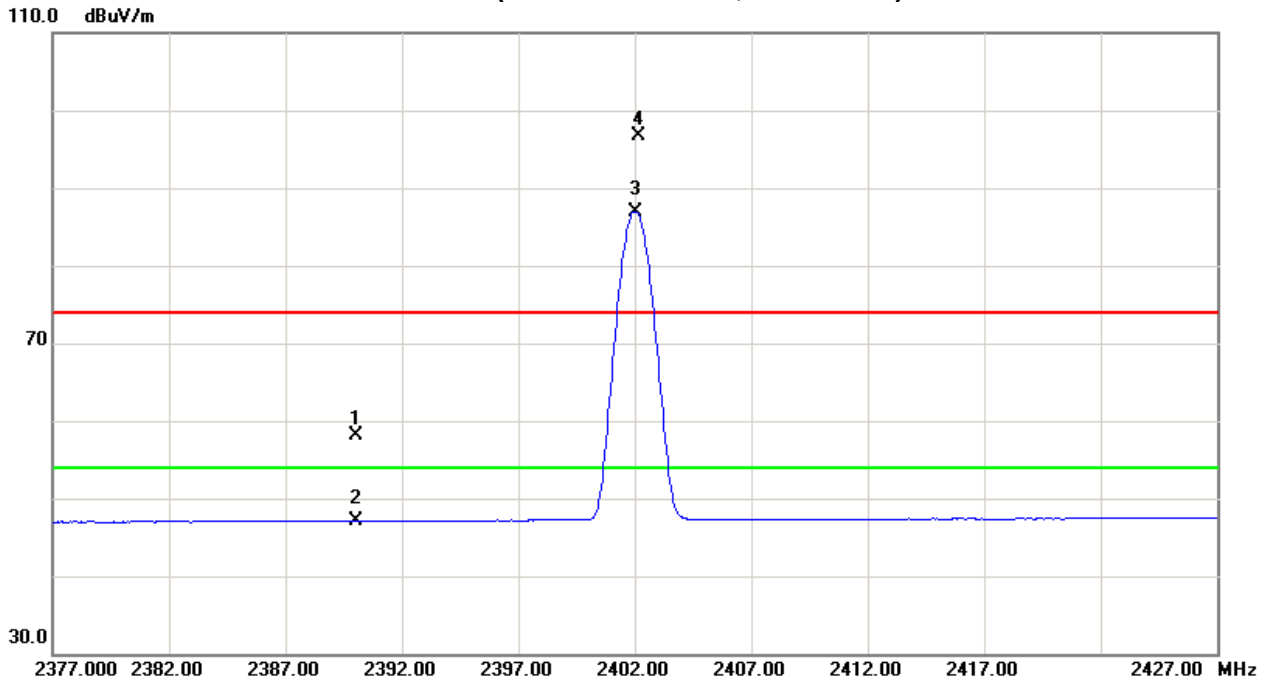



TX CH39 (Above 1000 MHz, Vertical)

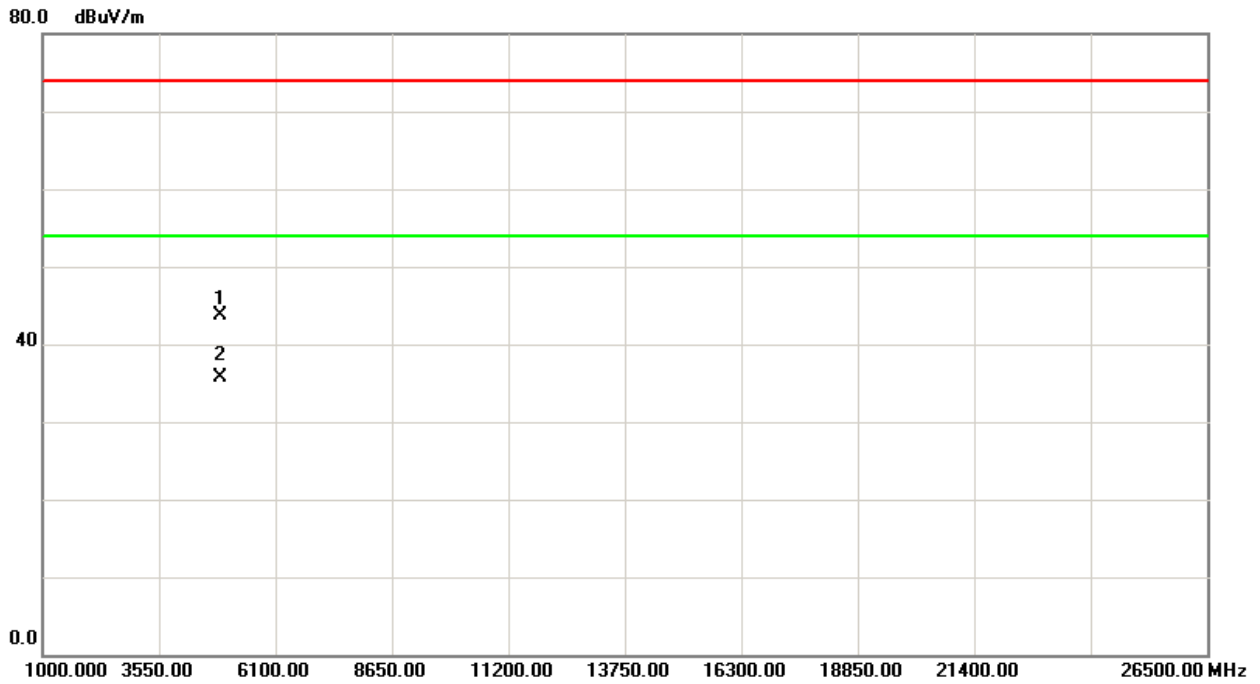
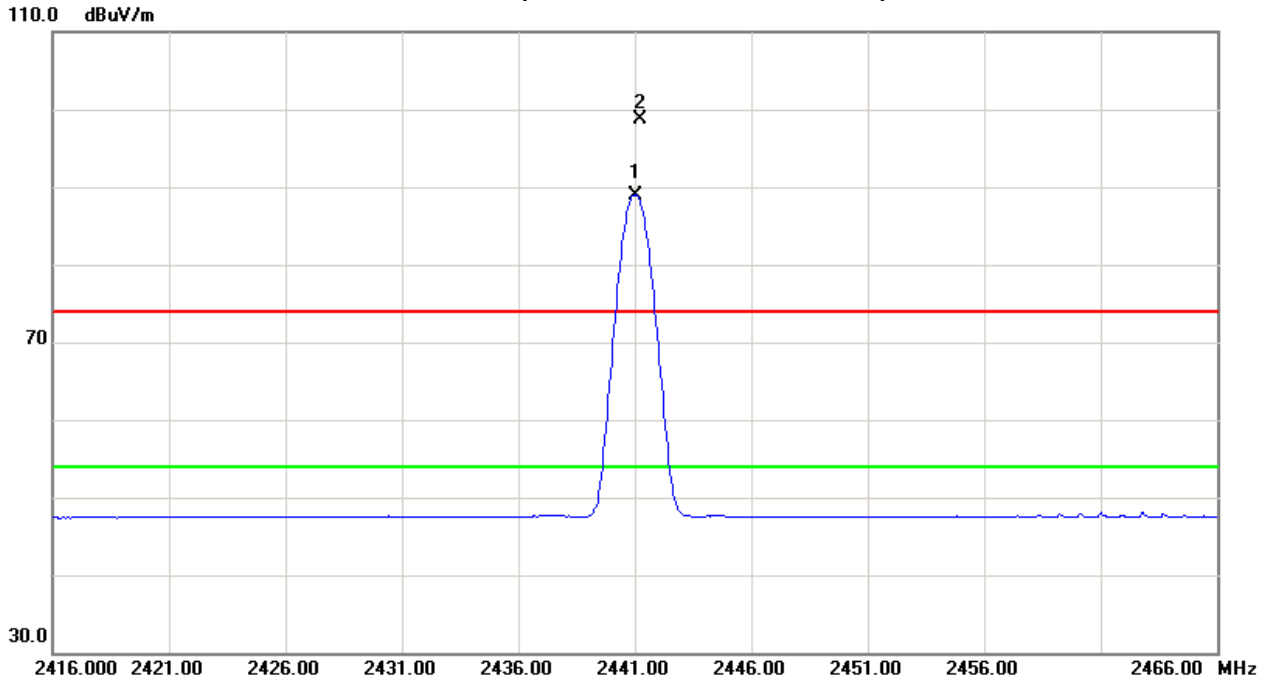



TX CH39 (Above 1000 MHz, Horizontal)

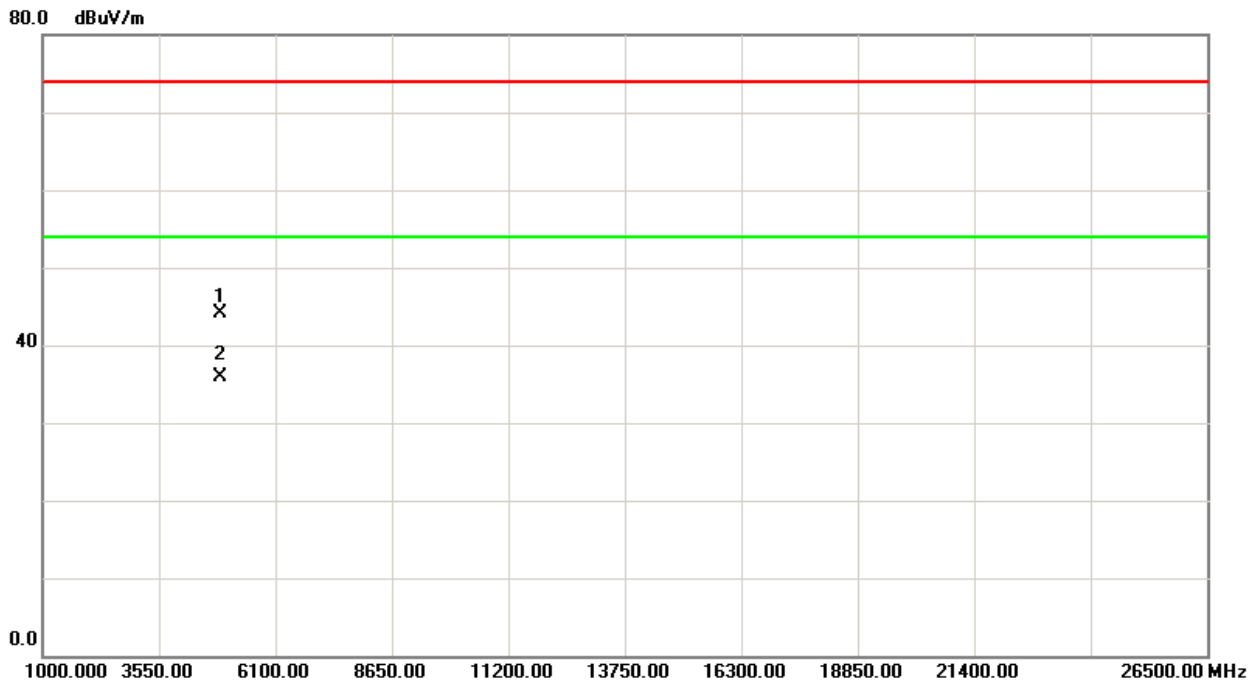
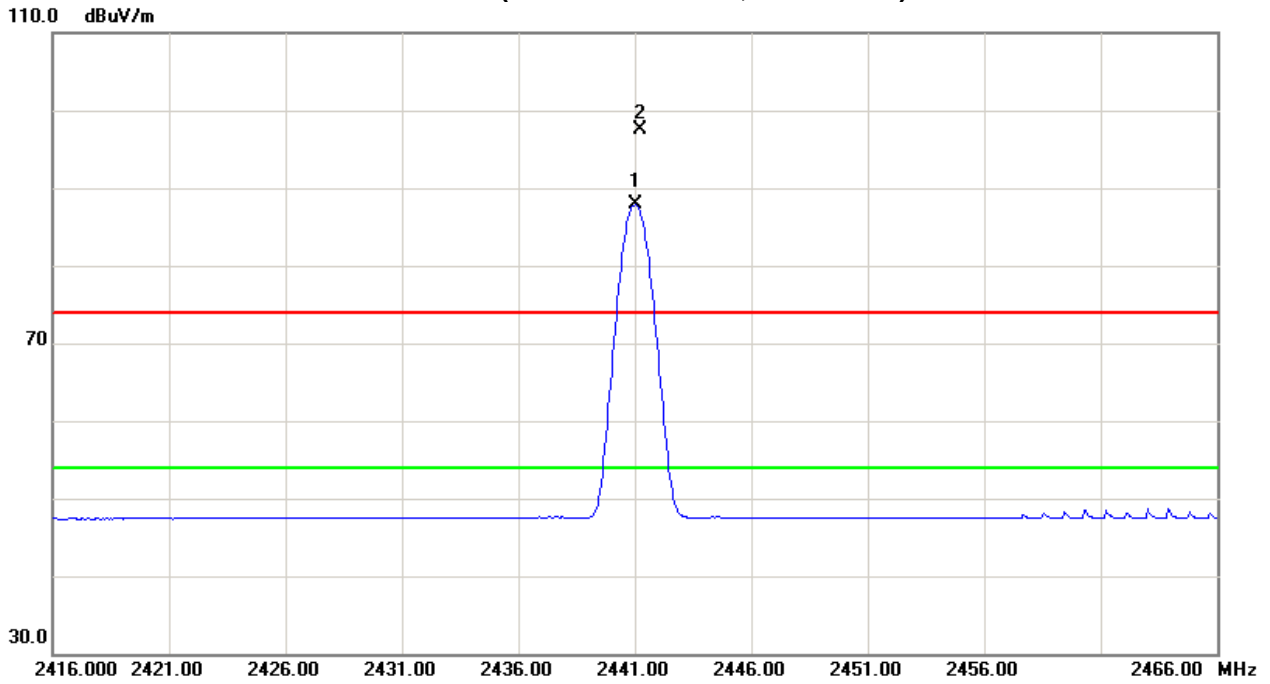



TX CH78 (Above 1000 MHz, Vertical)

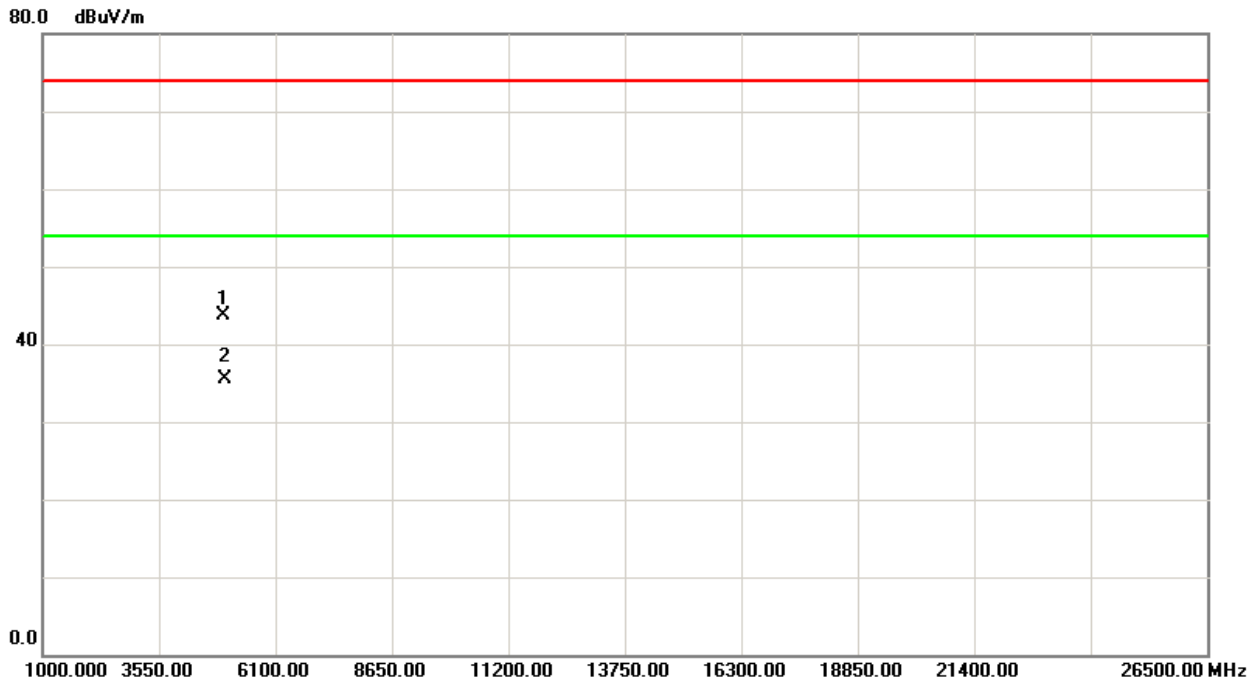
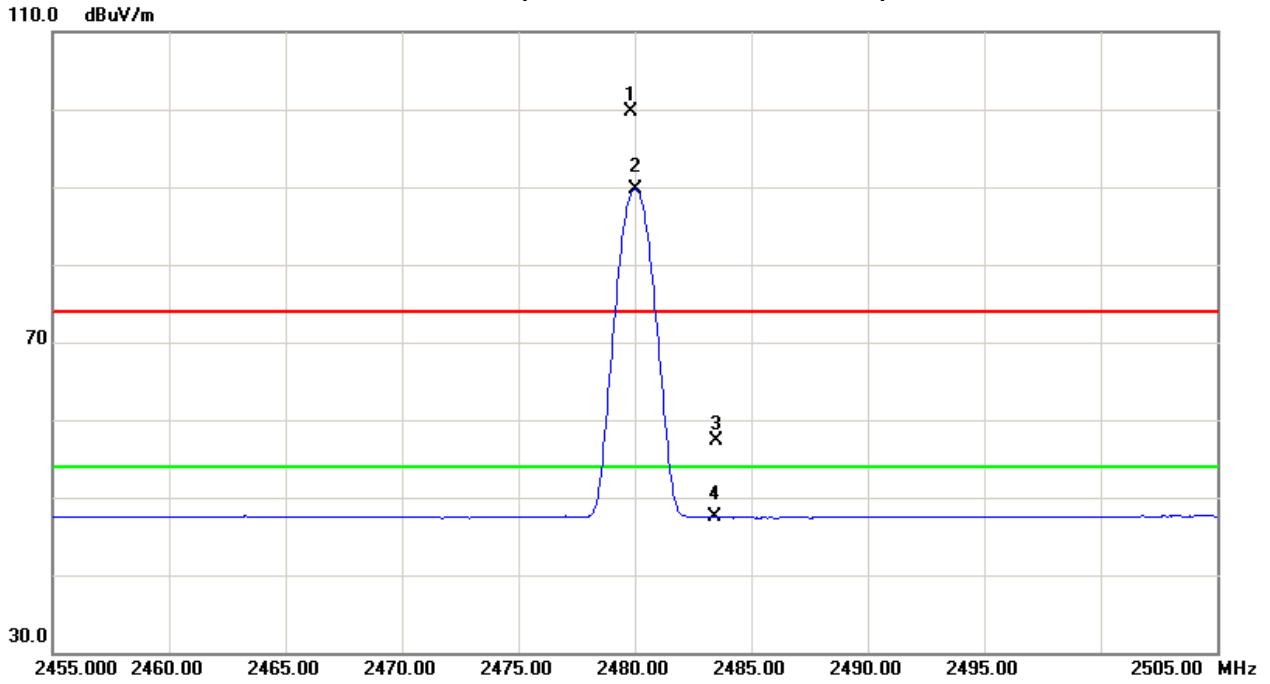



TX CH78 (Above 1000 MHz, Horizontal)

110.0 dBuV/m

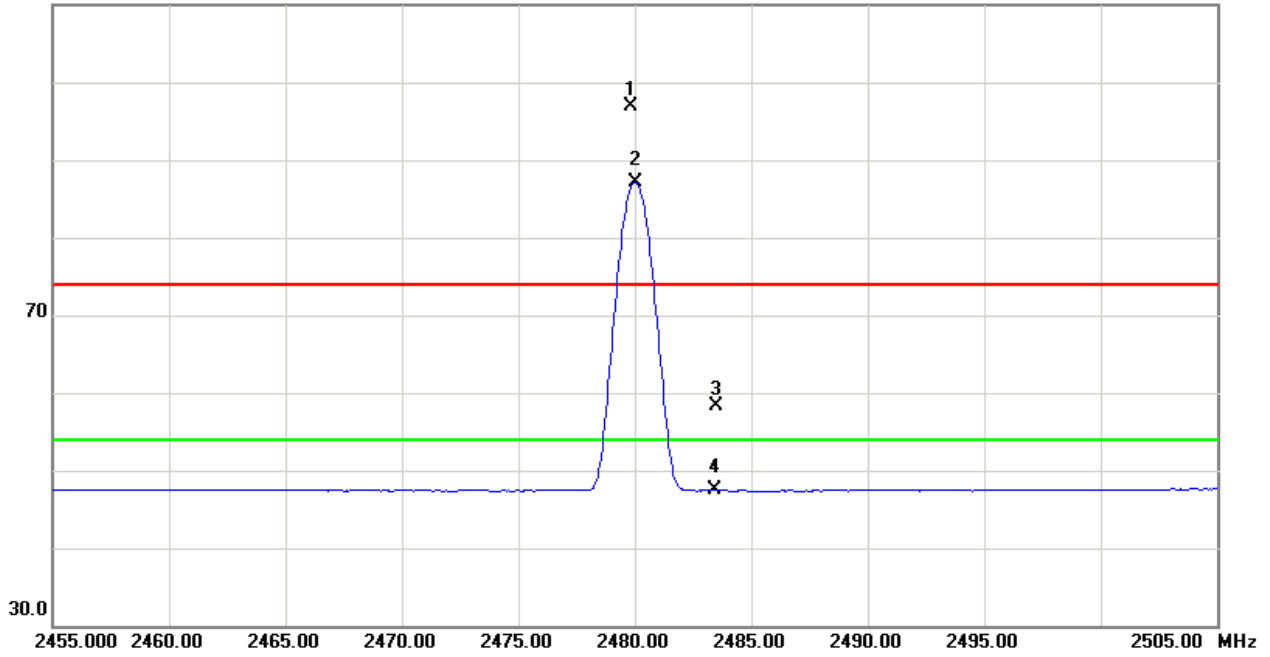

80.0 dBuV/m

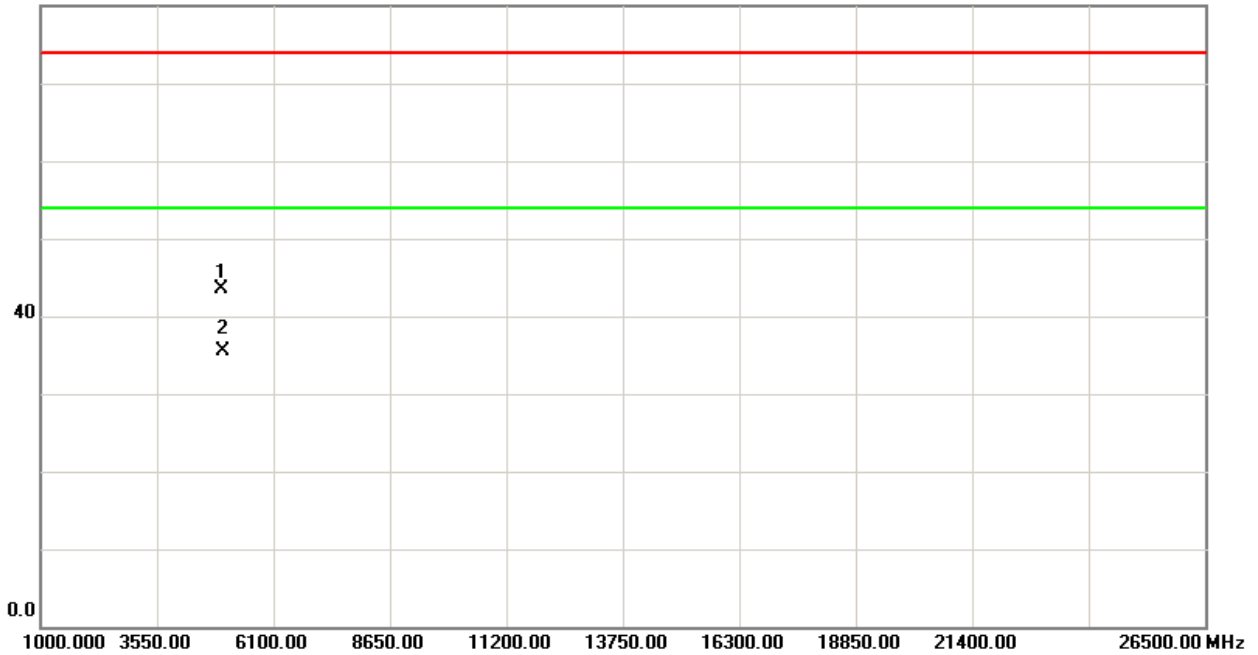



Test Mode: TX 2402MHz_CH00_3Mbps

Freq. (MHz)	Ant.Pol. H/V	Reading		Ant./CF CF(dB)	Act.		Limit		Note
		Peak (dBuV)	AV (dBuV)		Peak (dBuV/m)	AV (dBuV/m)	Peak (dBuV/m)	AV (dBuV/m)	
2390.00	V	23.61	13.03	34.09	57.70	47.12	74.00	54.00	X/E
2401.95	V	64.41	52.86	34.12	98.53	86.98			X/F
4803.24	V	37.23	29.14	6.38	43.61	35.52	74.00	54.00	X/H

Freq. (MHz)	Ant.Pol. H/V	Reading		Ant./CF CF(dB)	Act.		Limit		Note
		Peak (dBuV)	AV (dBuV)		Peak (dBuV/m)	AV (dBuV/m)	Peak (dBuV/m)	AV (dBuV/m)	
2390.00	H	23.31	13.02	34.09	57.40	47.11	74.00	54.00	X/E
2401.95	H	62.13	50.55	34.12	96.25	84.67			X/F
4804.62	H	37.60	29.53	6.38	43.98	35.91	74.00	54.00	X/H

Test Mode: TX 2441MHz_CH39_3Mbps

Freq. (MHz)	Ant.Pol. H/V	Reading		Ant./CF CF(dB)	Act.		Limit		Note
		Peak (dBuV)	AV (dBuV)		Peak (dBuV/m)	AV (dBuV/m)	Peak (dBuV/m)	AV (dBuV/m)	
2440.95	V	62.64	51.07	34.25	96.89	85.32			X/F
4882.15	V	37.48	28.93	6.61	44.09	35.54	74.00	54.00	X/H

Freq. (MHz)	Ant.Pol. H/V	Reading		Ant./CF CF(dB)	Act.		Limit		Note
		Peak (dBuV)	AV (dBuV)		Peak (dBuV/m)	AV (dBuV/m)	Peak (dBuV/m)	AV (dBuV/m)	
2440.95	H	63.25	51.71	34.25	97.50	85.96			X/F
4882.15	H	37.50	29.61	6.61	44.11	36.22	74.00	54.00	X/H

Test Mode: TX 2480MHz_CH78_3Mbps

Freq. (MHz)	Ant.Pol. H/V	Reading		Ant./CF CF(dB)	Act.		Limit		Note
		Peak (dBuV)	AV (dBuV)		Peak (dBuV/m)	AV (dBuV/m)	Peak (dBuV/m)	AV (dBuV/m)	
2479.80	V	62.01	46.72	34.36	96.37	81.08			X/F
2483.50	V	23.87	13.06	34.37	58.24	47.43	74.00	54.00	X/E
4960.20	V	36.81	28.70	6.83	43.64	35.53	74.00	54.00	X/H

Freq. (MHz)	Ant.Pol. H/V	Reading		Ant./CF CF(dB)	Act.		Limit		Note
		Peak (dBuV)	AV (dBuV)		Peak (dBuV/m)	AV (dBuV/m)	Peak (dBuV/m)	AV (dBuV/m)	
2479.80	H	62.50	47.22	34.36	96.86	81.58			X/F
2483.50	H	23.47	13.03	34.37	57.84	47.40	74.00	54.00	X/E
4960.20	H	36.99	28.76	6.83	43.82	35.59	74.00	54.00	X/H



TX CH00(Above 1000 MHz, Vertical)

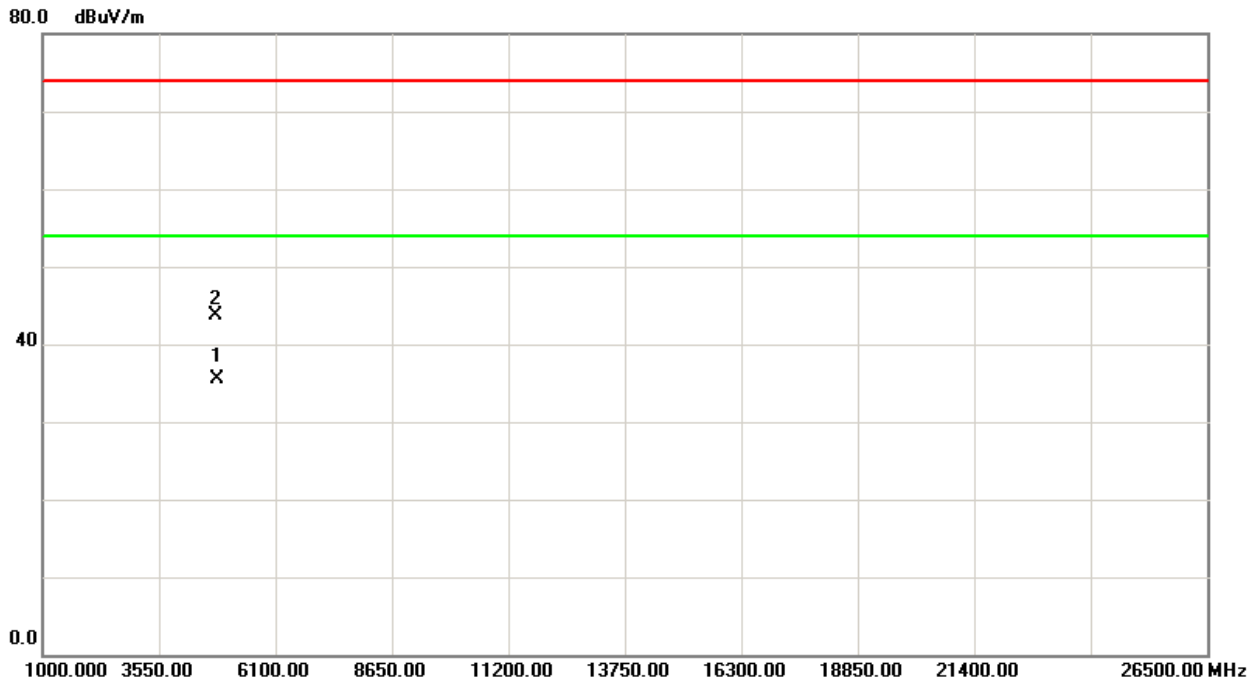
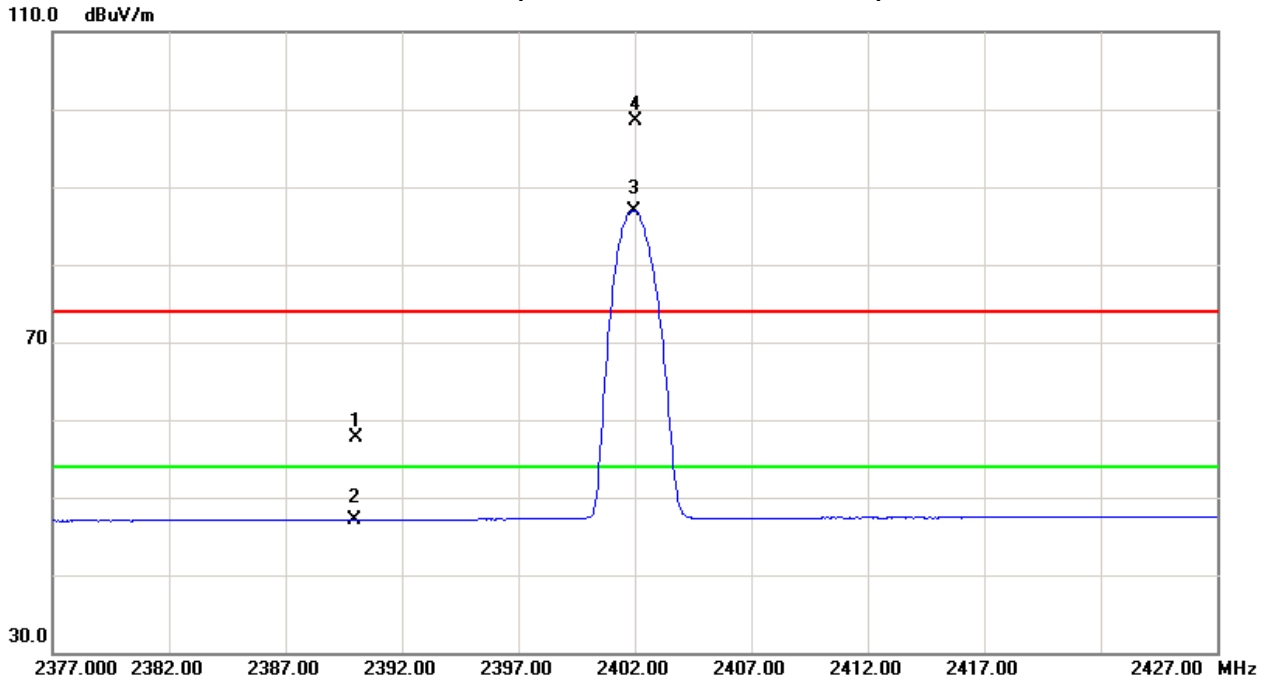



TX CH00(Above 1000 MHz, Horizontal)

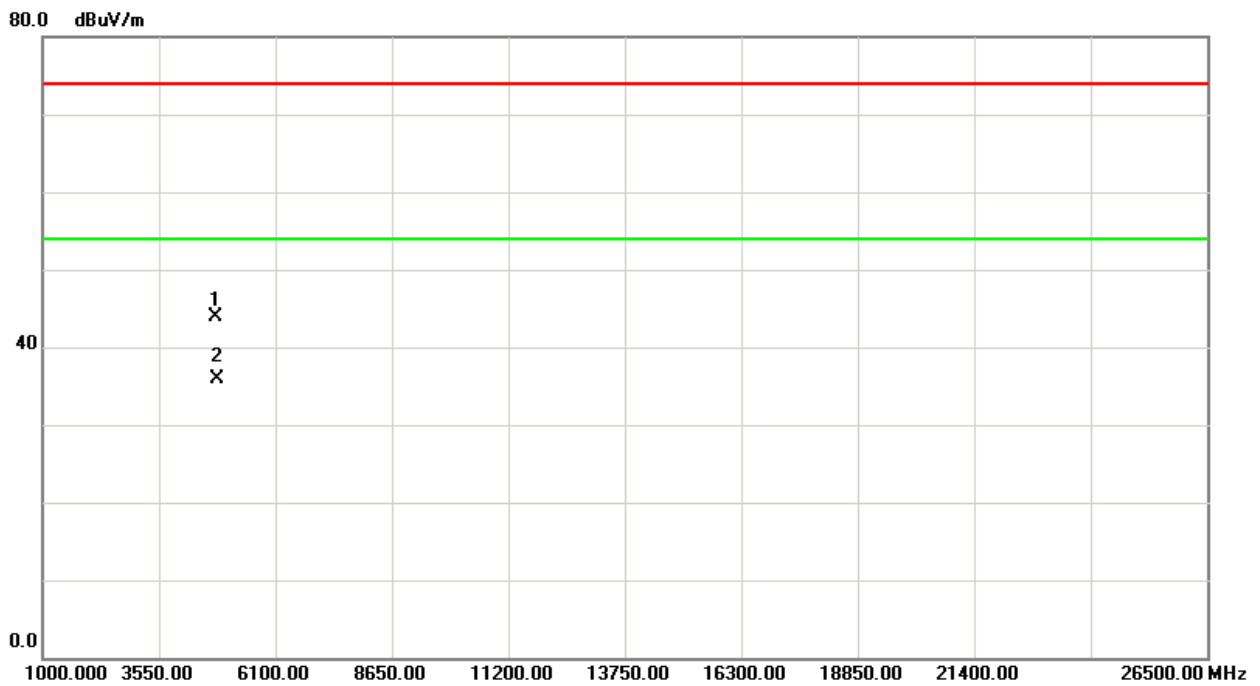
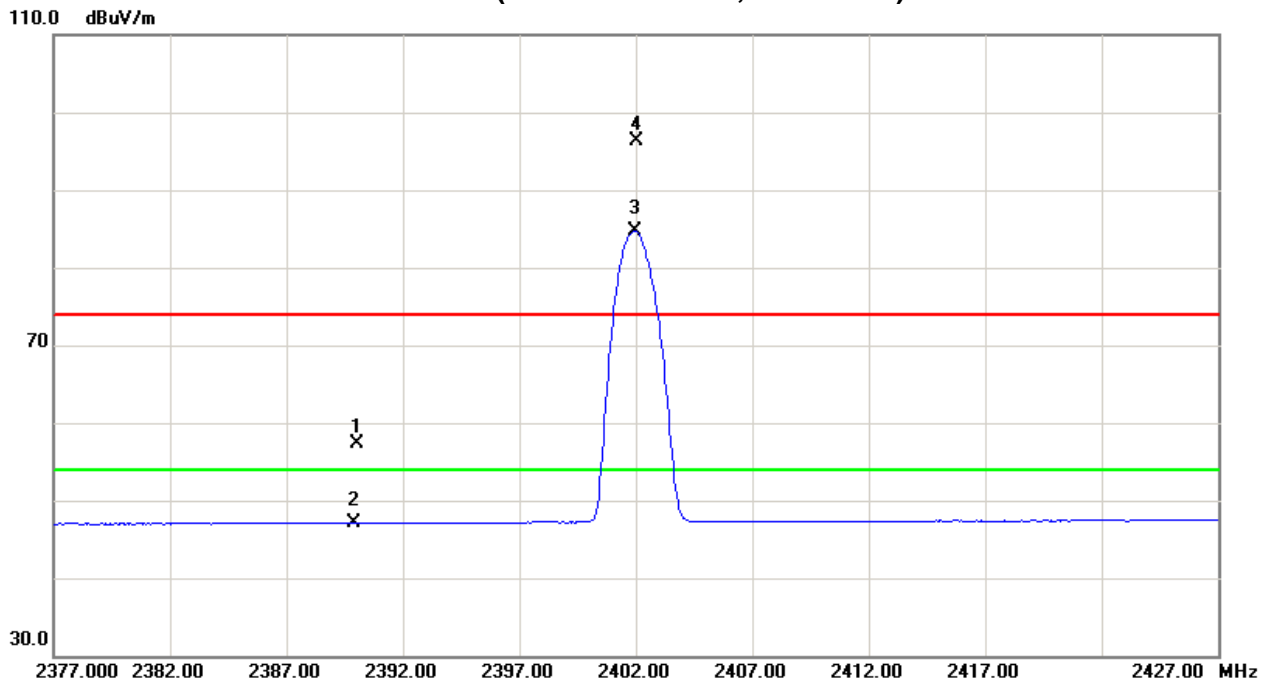



TX CH39 (Above 1000 MHz, Vertical)

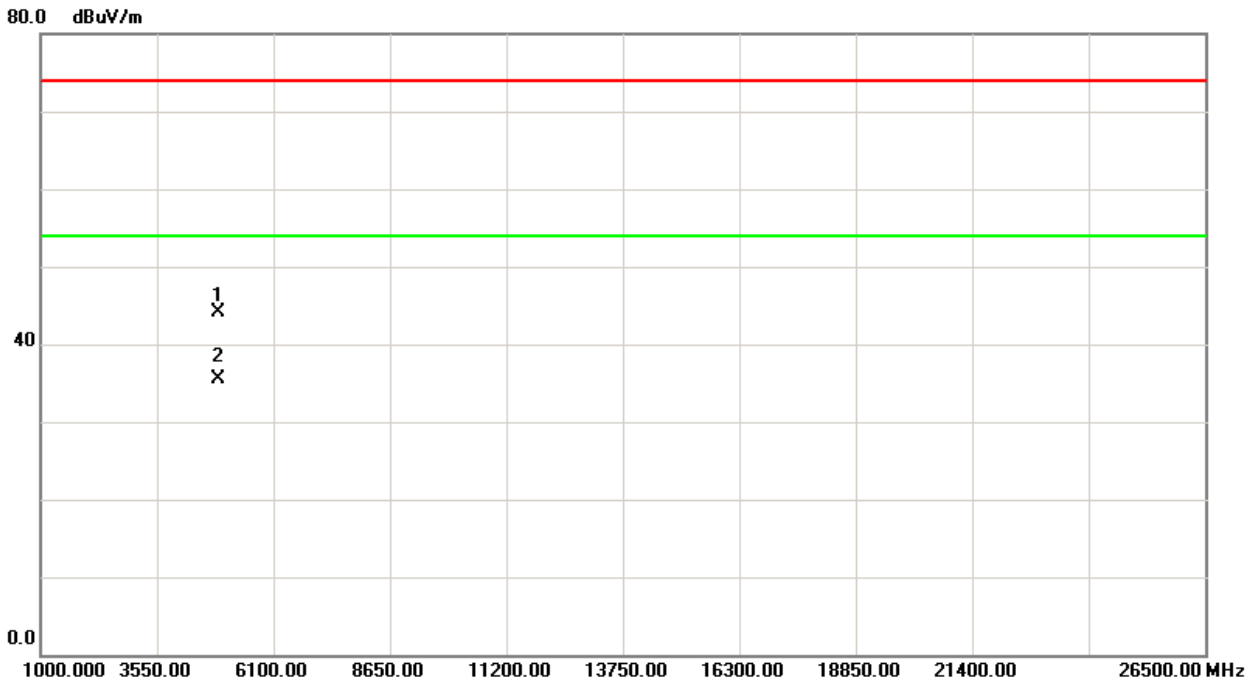
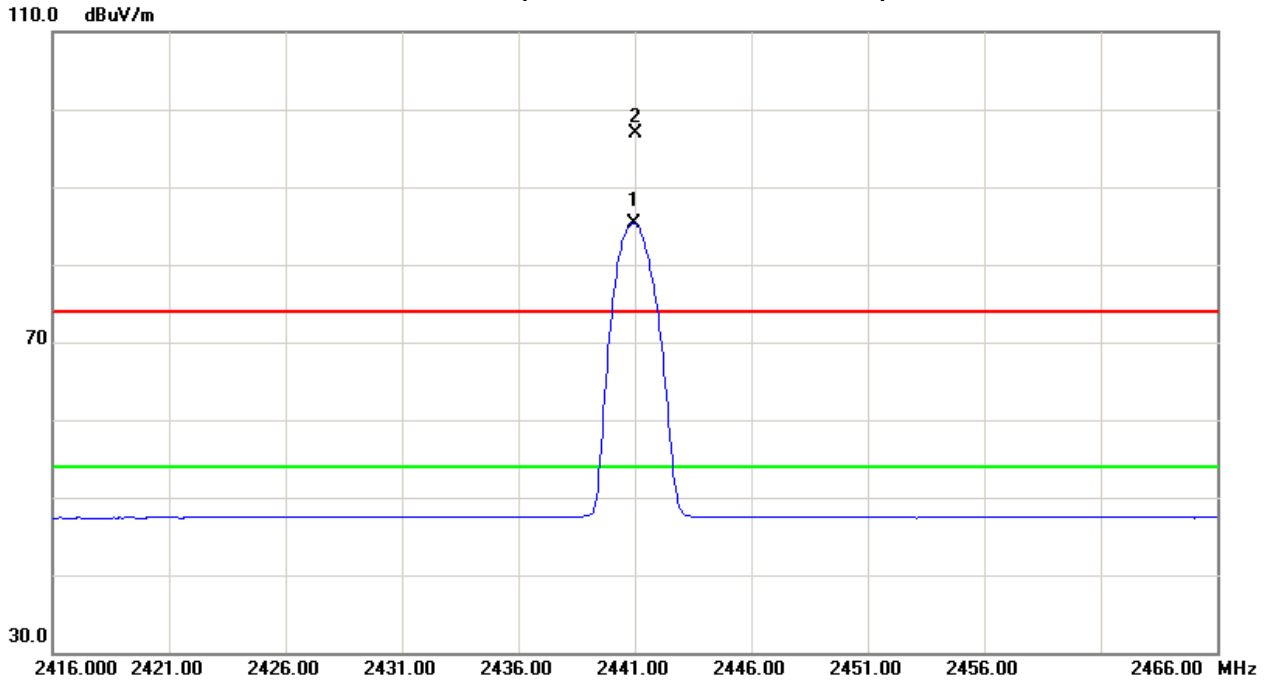



TX CH39 (Above 1000 MHz, Horizontal)

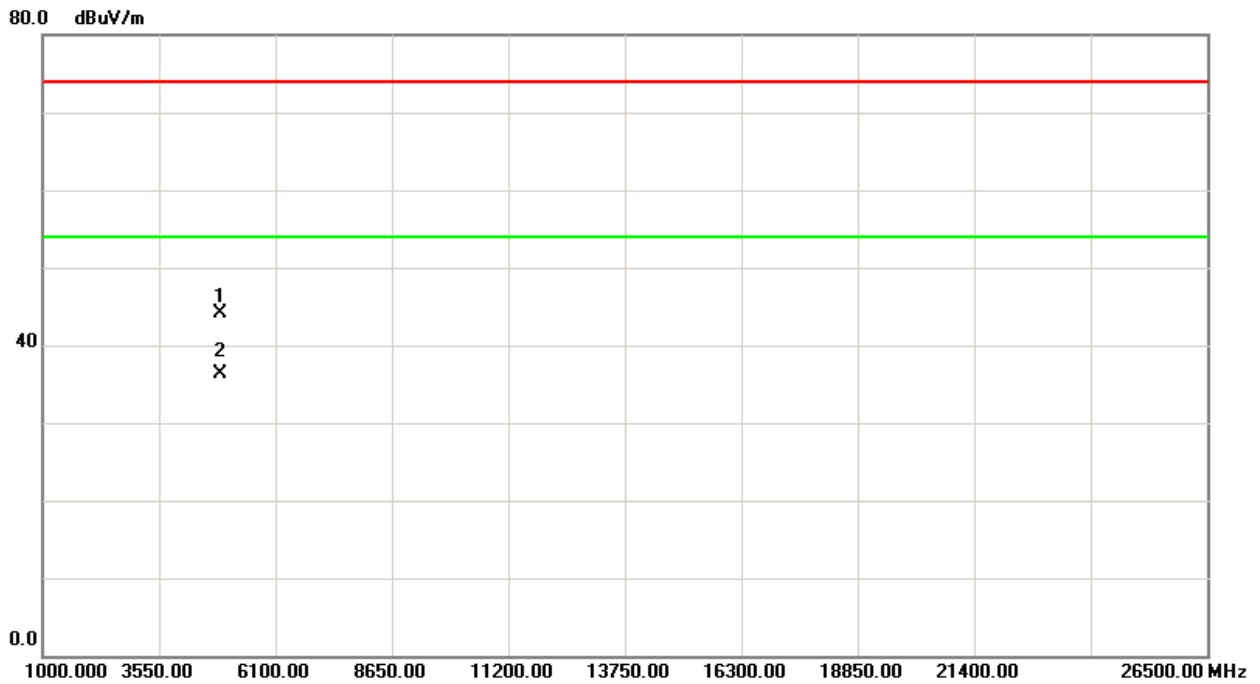
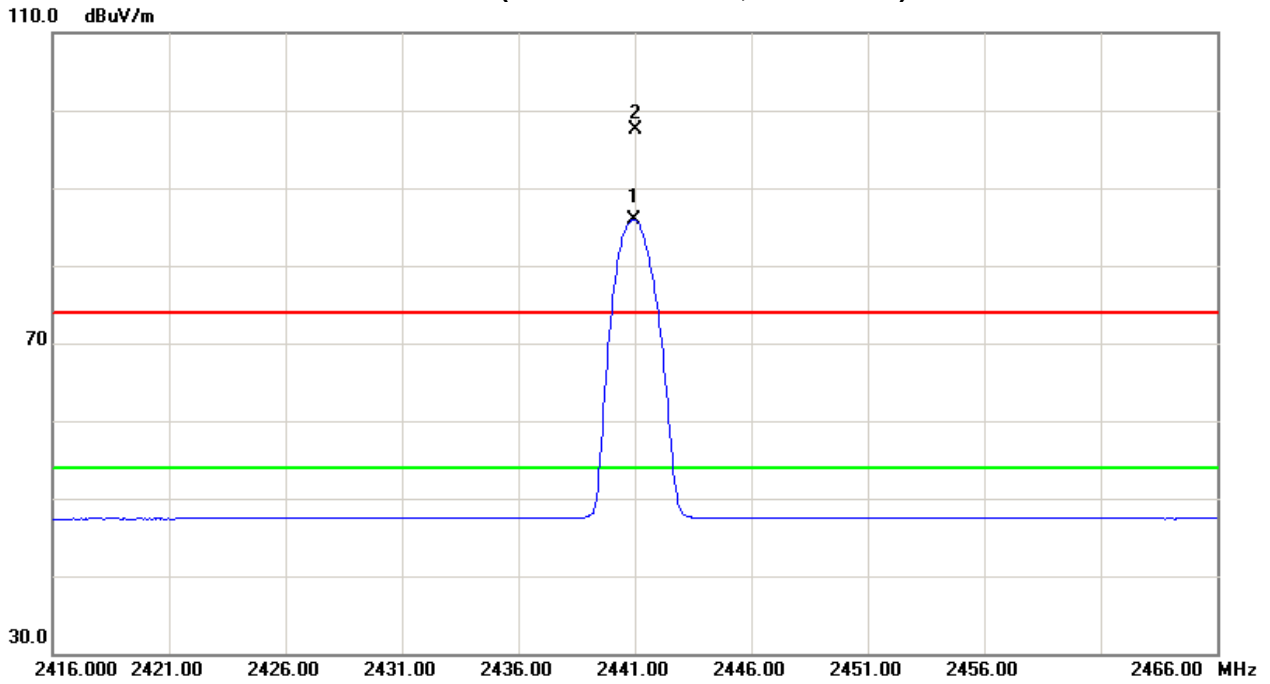



TX CH78 (Above 1000 MHz, Vertical)

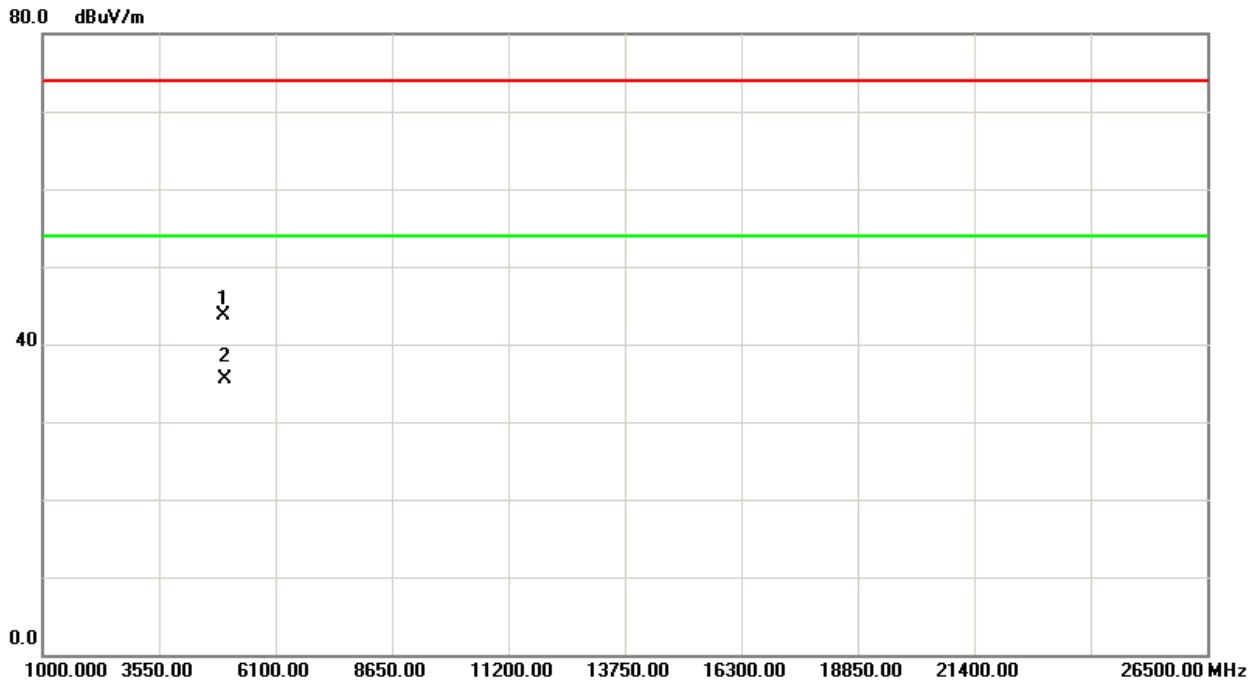
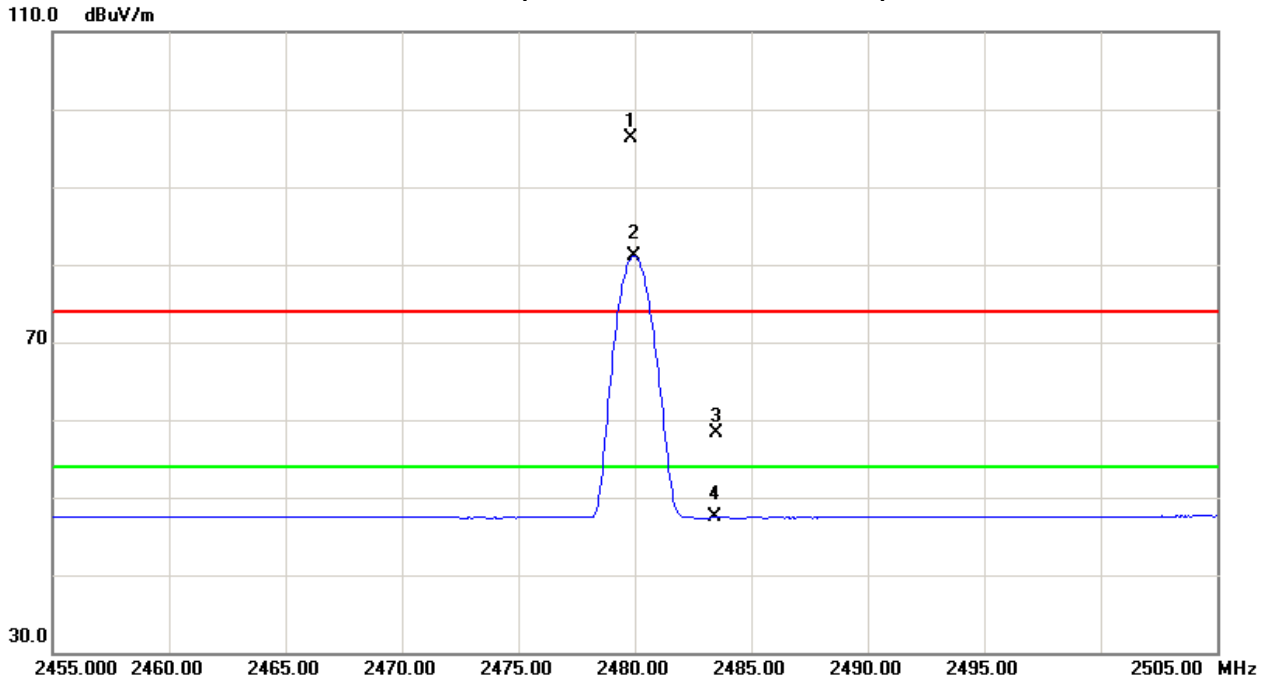



TX CH78 (Above 1000 MHz, Horizontal)

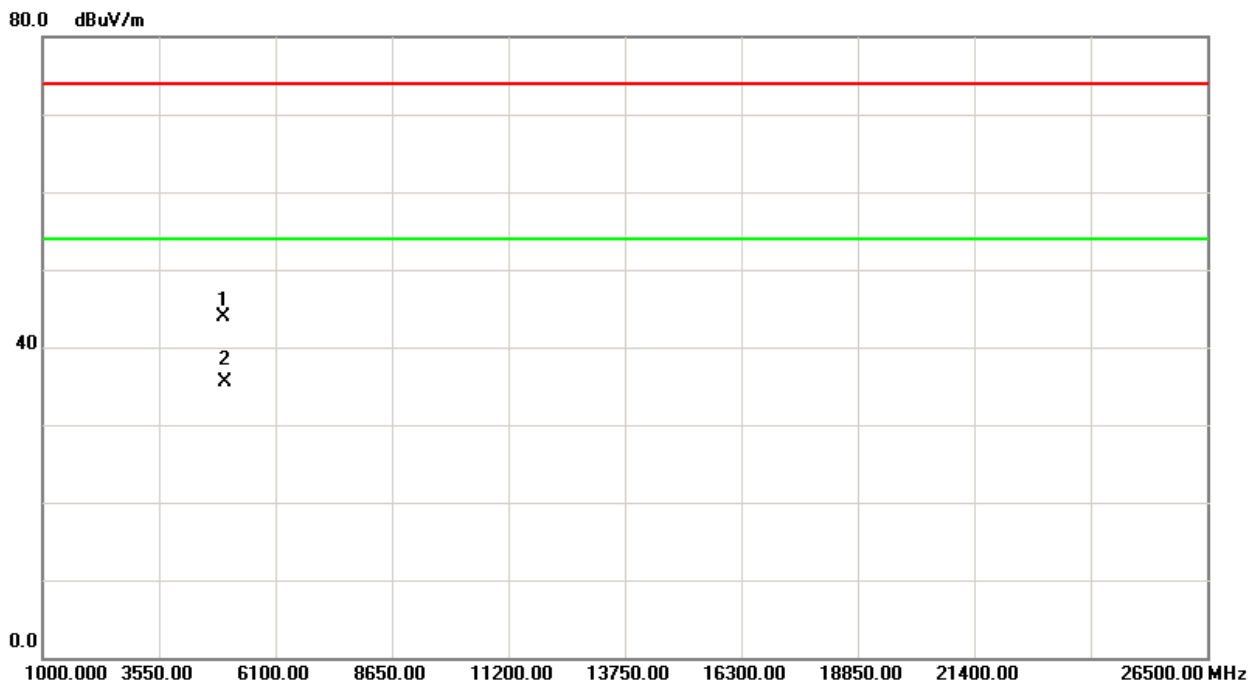
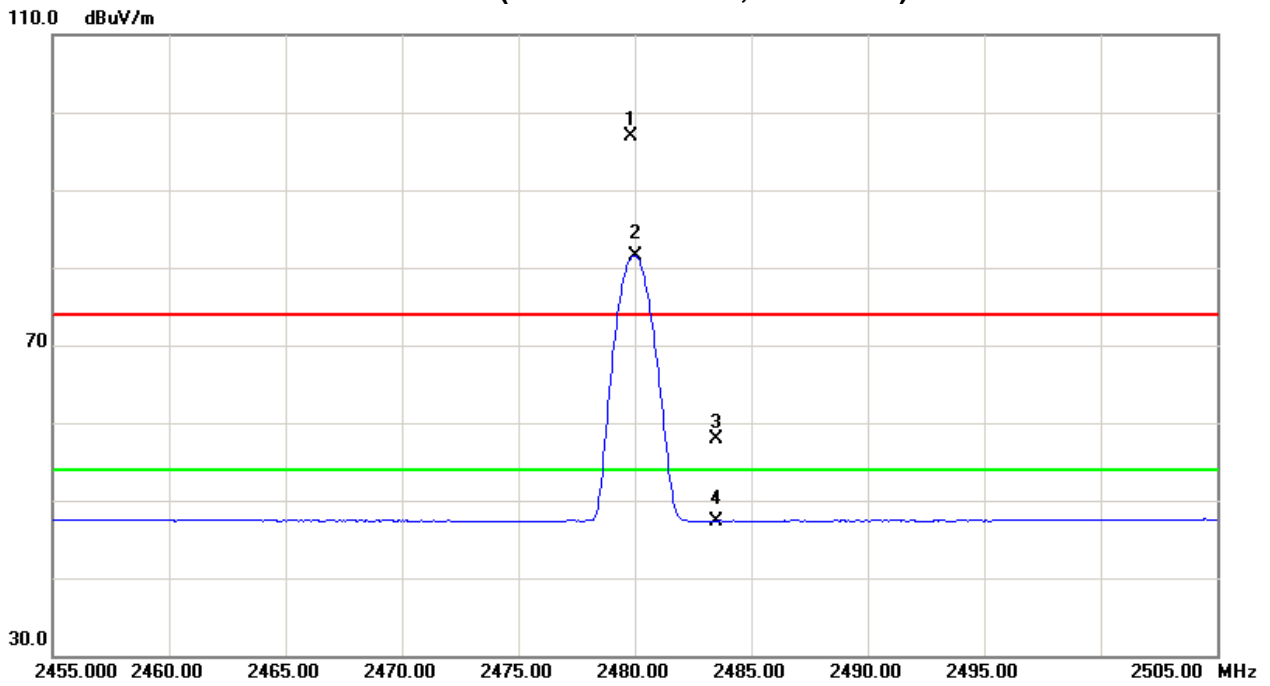



5. NUMBER OF HOPPING CHANNEL

5.1 APPLIED PROCEDURES

FCC Part15 (15.247) , Subpart C/ RSS-GEN and RSS-210			
Section	Test Item	Frequency Range (MHz)	Result
15.247(a)(1)(iii) RSS-210, Issue 8, Annex 8, A8.1(d)	Number of Hopping Channel	2400-2483.5	PASS

Spectrum Parameters	Setting
Attenuation	Auto
Span Frequency	> Operating Frequency Range
RBW	100 KHz
VBW	100 KHz
Detector	Peak
Trace	Max Hold
Sweep Time	Auto

5.1.1 TEST PROCEDURE

- a. The EUT was directly connected to the spectrum analyzer and antenna output port as show in the block diagram below,
- b. Spectrum Setting: RBW=100KHz, VBW=100KHz, Sweep time = Auto.

5.1.2 DEVIATION FROM STANDARD

No deviation.

5.1.3 TEST SETUP

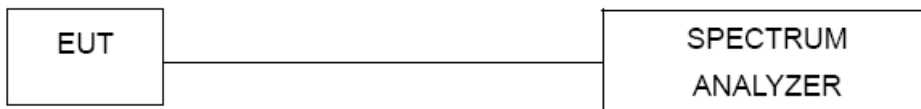

5.1.4 EUT OPERATION CONDITIONS

The EUT tested system was configured as the statements of 4.1.5 Unless otherwise a special operating condition is specified in the follows during the testing.

5.1.5 EUT TEST CONDITIONS

Temperature: 25°C
 Relative Humidity: 55%
 Test Voltage: 120V/60Hz



5.1.6 TEST RESULTS

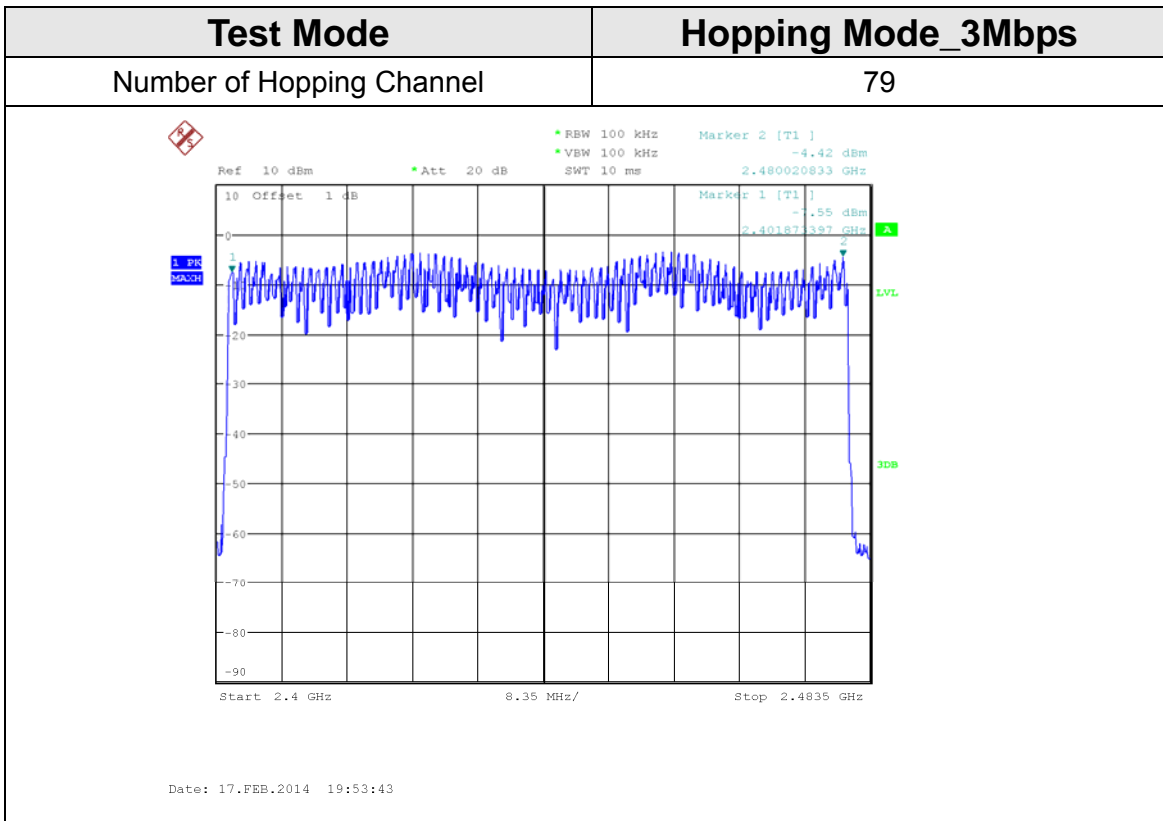
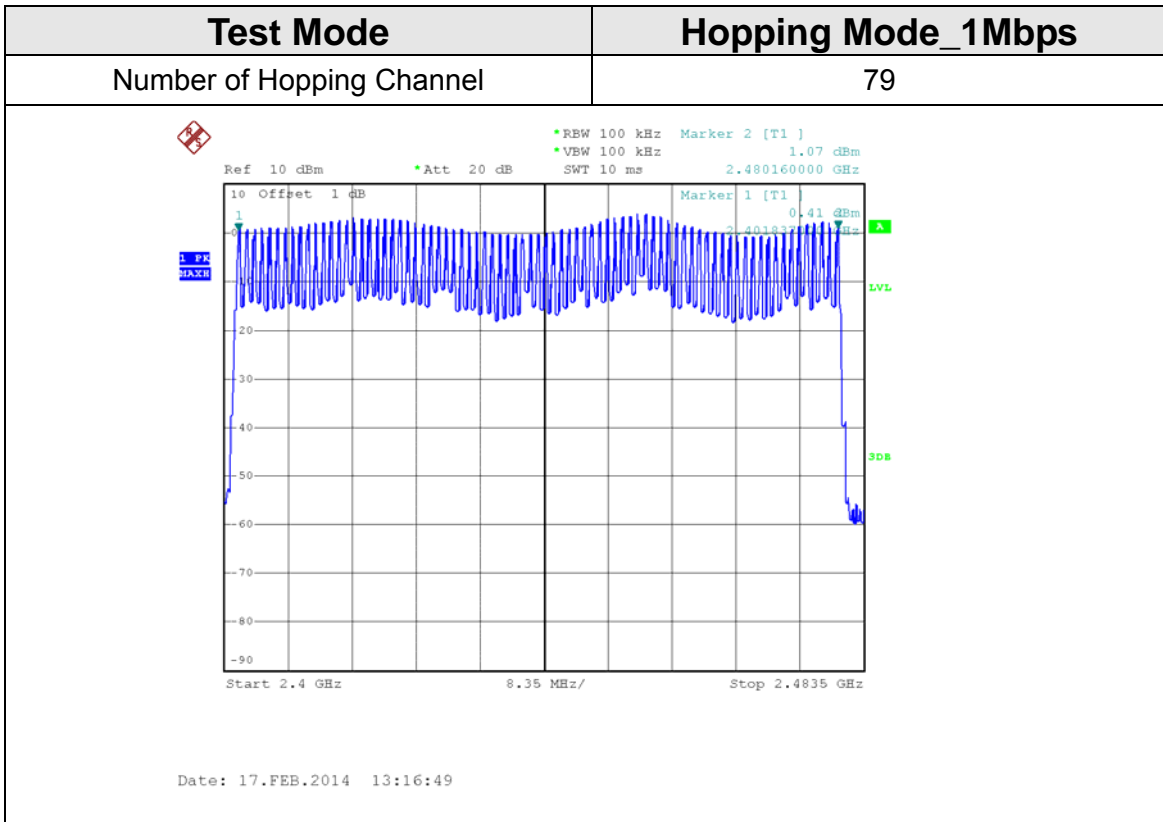



6. AVERAGE TIME OF OCCUPANCY

6.1 APPLIED PROCEDURES / LIMIT

FCC Part15 (15.247) , Subpart C/ RSS-GEN and RSS-210				
Section	Test Item	Limit	Frequency Range (MHz)	Result
15.247(a)(1)(iii) RSS-210, Issue 8, Annex 8, A8.1(d)	Average Time of Occupancy	0.4sec	2400-2483.5	PASS

6.1.1 TEST PROCEDURE

- a. The transmitter output (antenna port) was connected to the spectrum analyzer
- b. Set RBW of spectrum analyzer to 1MHz and VBW to 1MHz.
- c. Use a video trigger with the trigger level set to enable triggering only on full pulses.
- d. Sweep Time is more than once pulse time.
- e. Set the center frequency on any frequency would be measure and set the frequency span to zero span.
- f. Measure the maximum time duration of one single pulse.
- g. Set the EUT for DH5, DH3 and DH1 packet transmitting.
- h. Measure the maximum time duration of one single pulse.
- i. DH5 Packet permit maximum $1600 / 79 / 6 = 3.37$ hops per second in each channel (5 time slots TX, 1 time slot RX). So, the dwell time is the time duration of the pulse times $3.37 \times 31.6 = 106.6$ within 31.6 seconds.
- j. DH3 Packet permit maximum $1600 / 79 / 4 = 5.06$ hops per second in each channel (3 time slots TX, 1 time slot RX). So, the dwell time is the time duration of the pulse times $5.06 \times 31.6 = 160$ within 31.6 seconds.
- k. DH1 Packet permit maximum $1600 / 79 / 2 = 10.12$ hops per second in each channel (1 time slot TX, 1 time slot RX). So, the dwell time is the time duration of the pulse times $10.12 \times 31.6 = 320$ within 31.6 seconds.

6.1.2 DEVIATION FROM STANDARD

No deviation.

6.1.3 TEST SETUP





6.1.4 EUT OPERATION CONDITIONS

The EUT tested system was configured as the statements of 4.1.5 Unless otherwise a special operating condition is specified in the follows during the testing.

6.1.5 EUT TEST CONDITIONS

Temperature: 25°C

Relative Humidity: 55%

Test Voltage: 120V/60Hz



6.1.6 TEST RESULTS

Test Mode: CH00_1Mbps				
Data Packet	Frequency (MHz)	Pulse Duration (ms)	Dwell Time (s)	Limits (s)
DH5	2402	2.9850	0.3184	0.4000
DH3	2402	1.7300	0.2768	0.4000
DH1	2402	0.4300	0.1376	0.4000

Test Mode: CH39_1Mbps				
Data Packet	Frequency (MHz)	Pulse Duration (ms)	Dwell Time (s)	Limits (s)
DH5	2441	2.9650	0.3163	0.4000
DH3	2441	1.7300	0.2768	0.4000
DH1	2441	0.4300	0.1376	0.4000

Test Mode: CH78_1Mbps				
Data Packet	Frequency (MHz)	Pulse Duration (ms)	Dwell Time (s)	Limits (s)
DH5	2480	2.9700	0.3168	0.4000
DH3	2480	1.7300	0.2768	0.4000
DH1	2480	0.4300	0.1376	0.4000

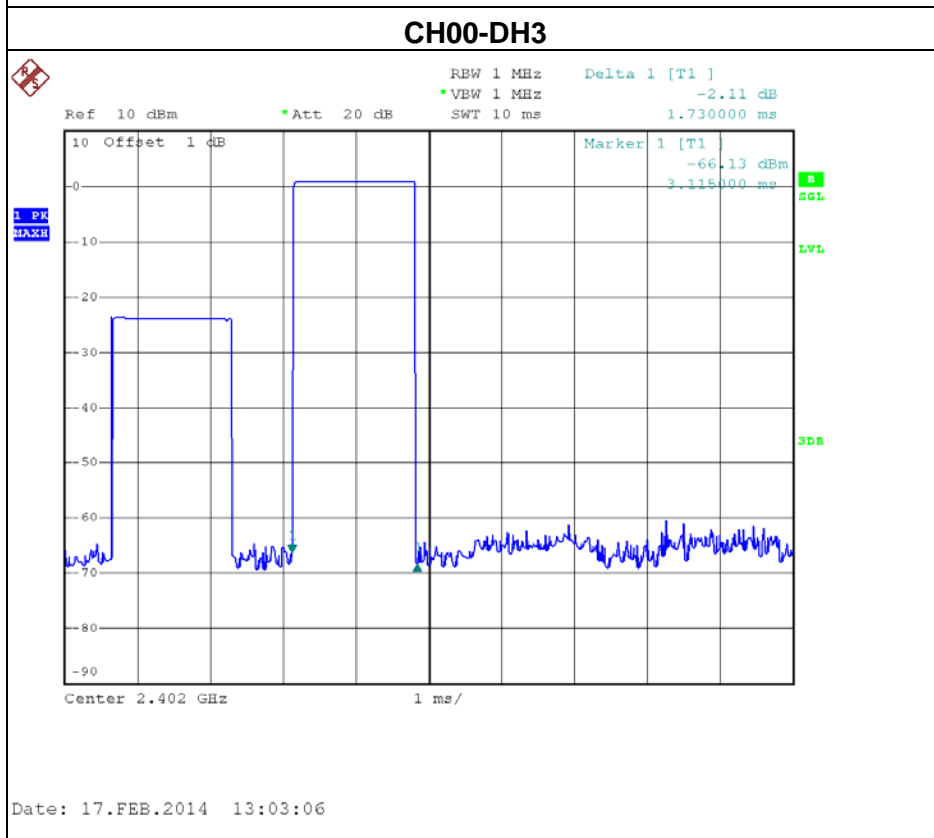
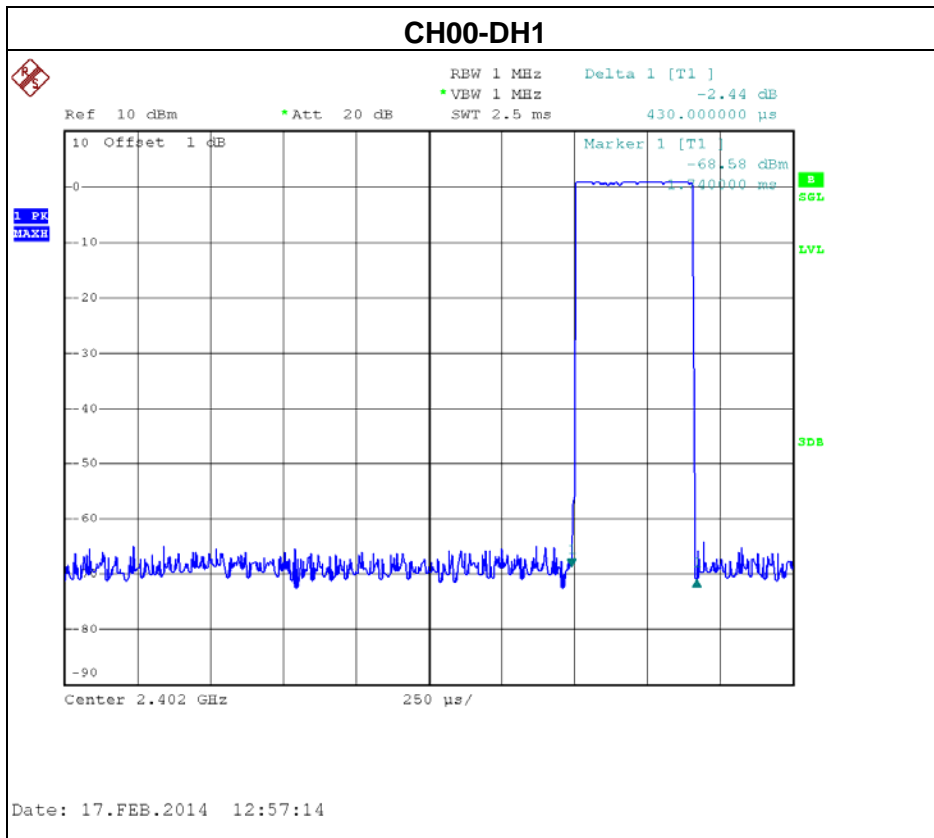

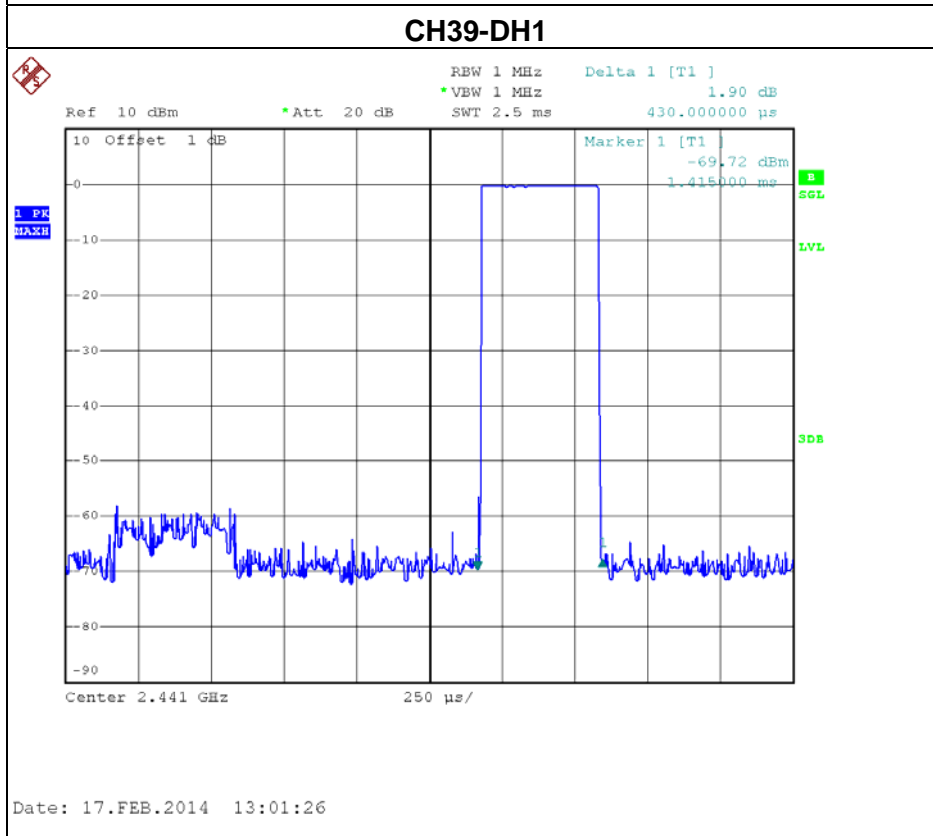
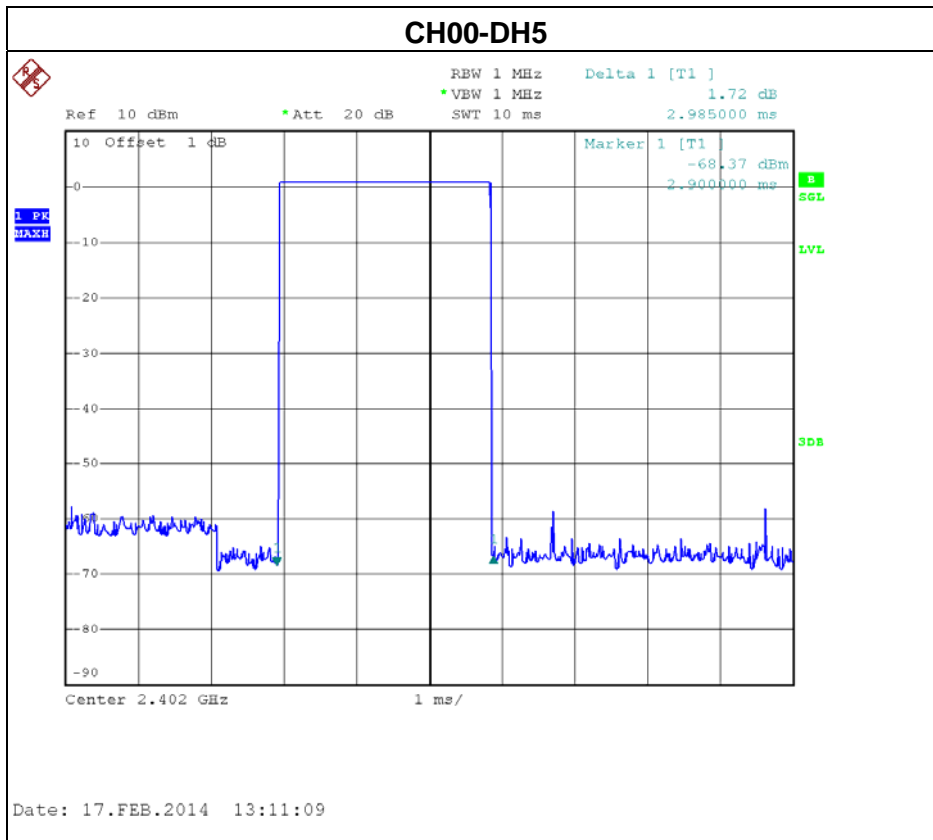

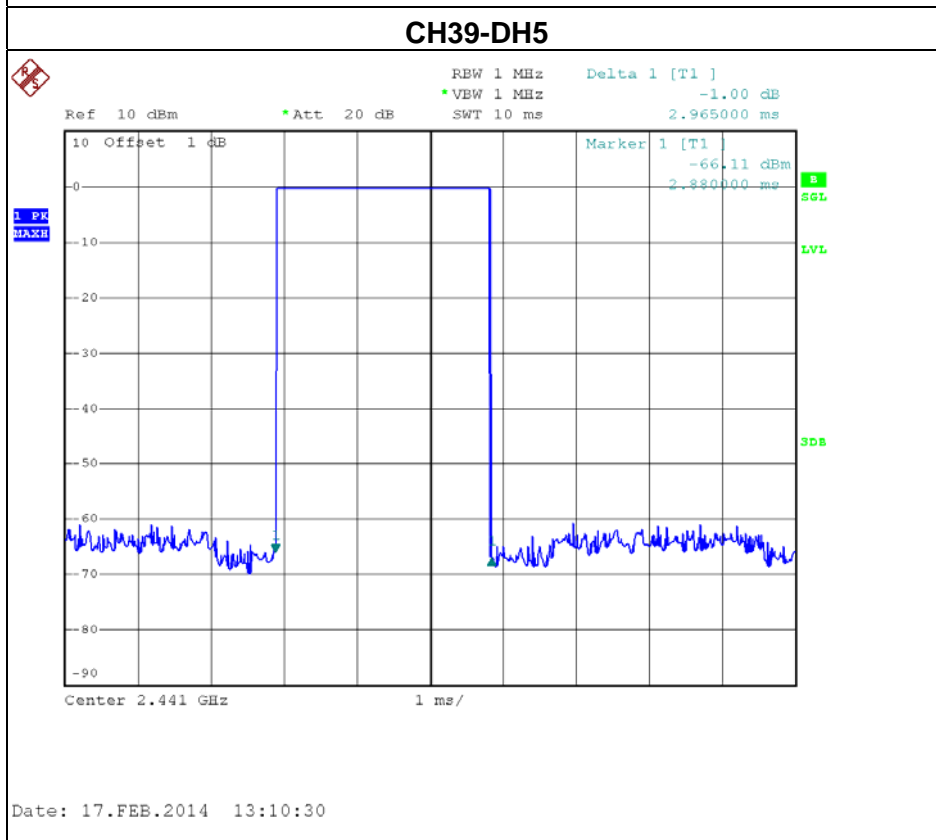
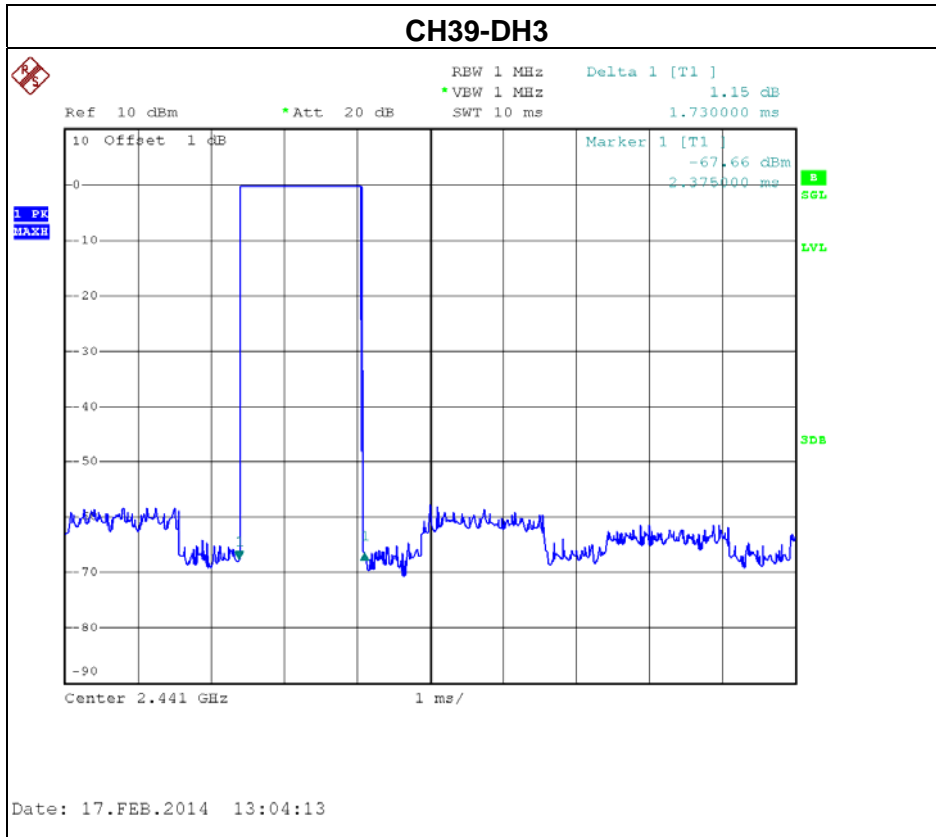

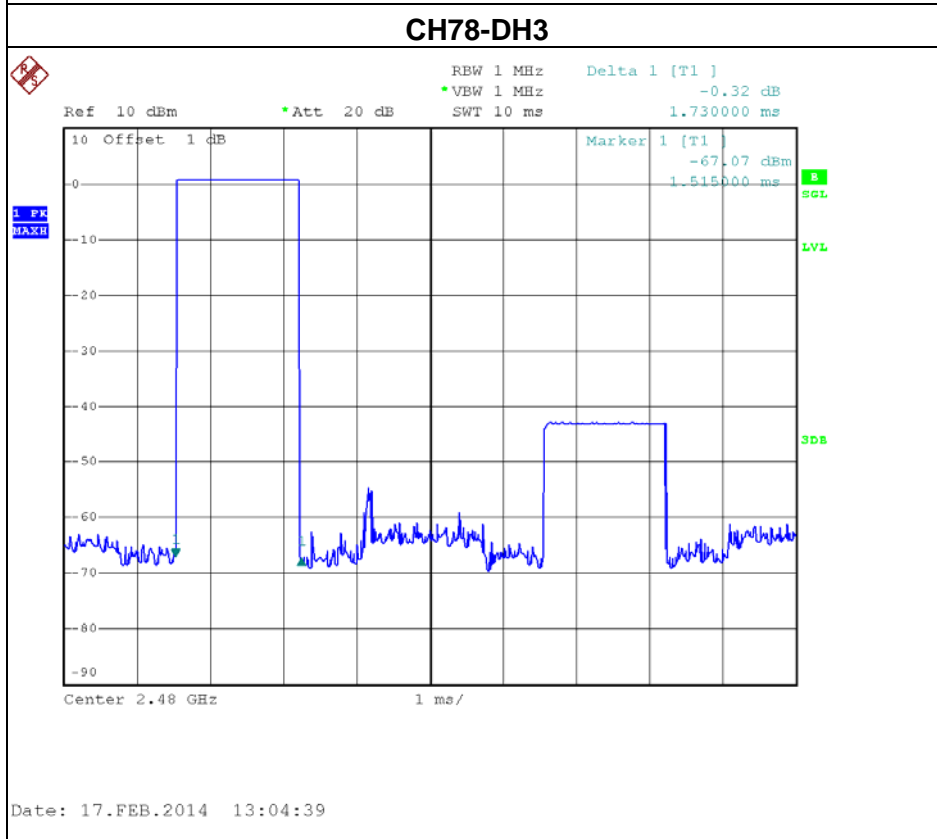
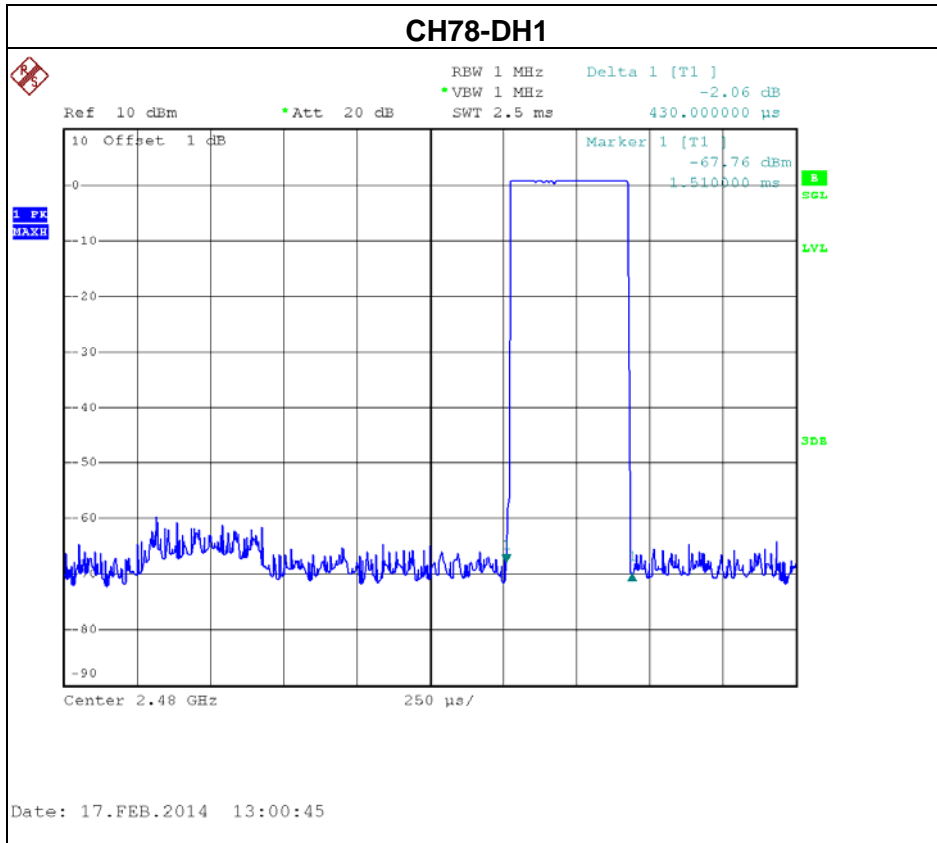

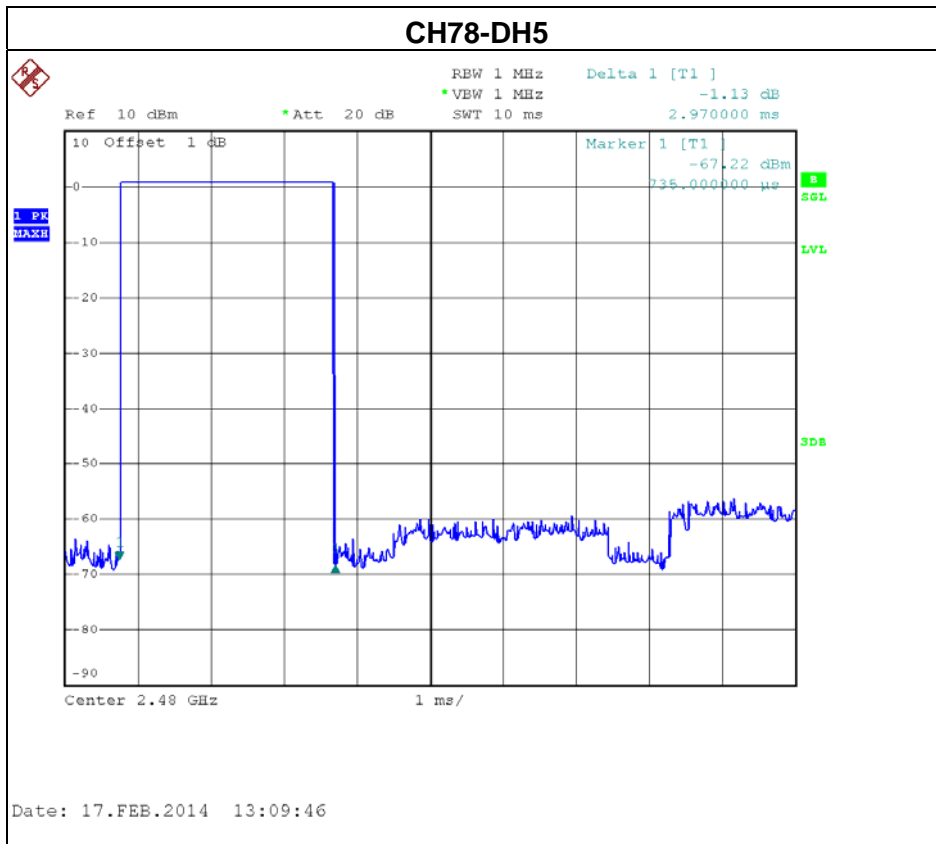



Test Mode: CH00_3Mbps

Data Packet	Frequency (MHz)	Pulse Duration (ms)	Dwell Time (s)	Limits (s)
DH5	2402	3.0128	0.3214	0.4000
DH3	2402	1.7147	0.2744	0.4000
DH1	2402	0.4247	0.1359	0.4000

Test Mode: CH39_3Mbps

Data Packet	Frequency (MHz)	Pulse Duration (ms)	Dwell Time (s)	Limits (s)
DH5	2441	2.9647	0.3162	0.4000
DH3	2441	1.7147	0.2744	0.4000
DH1	2441	0.4327	0.1385	0.4000

Test Mode: CH78_3Mbps

Data Packet	Frequency (MHz)	Pulse Duration (ms)	Dwell Time (s)	Limits (s)
DH5	2480	2.9487	0.3145	0.4000
DH3	2480	1.7147	0.2744	0.4000
DH1	2480	0.4327	0.1385	0.4000

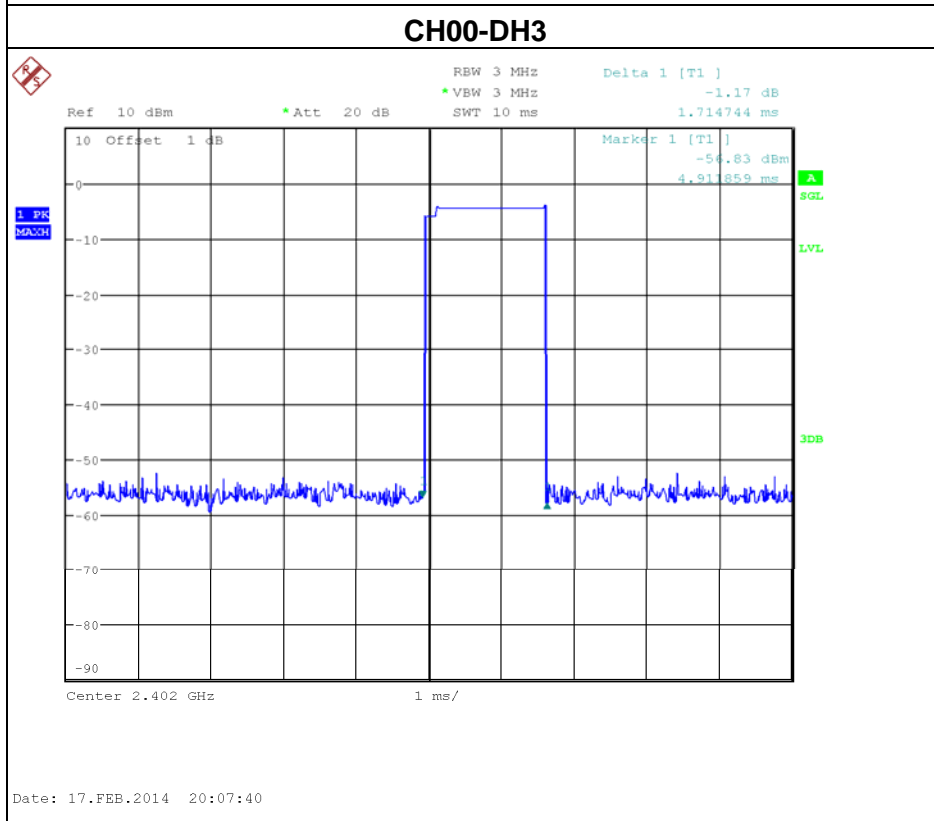
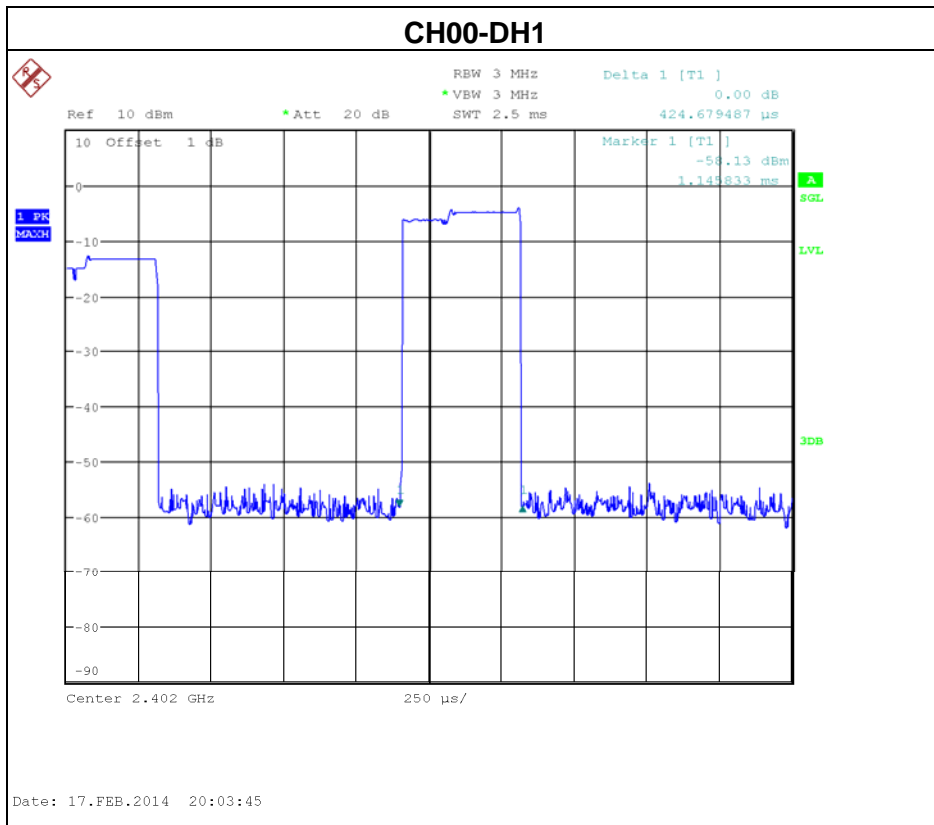

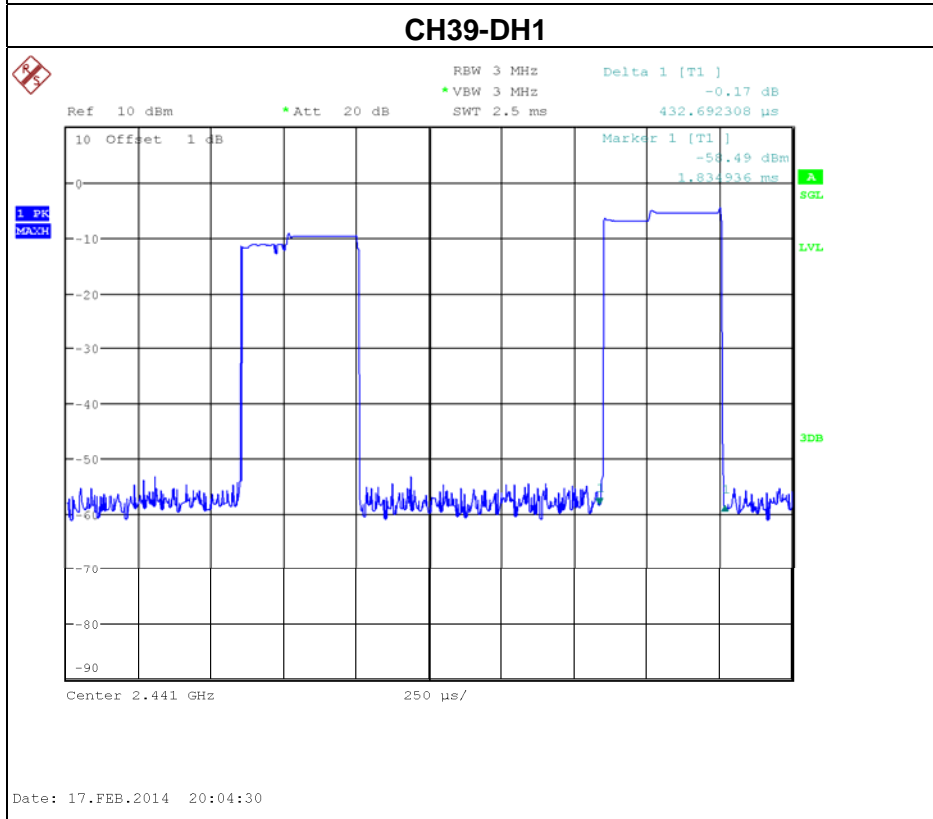
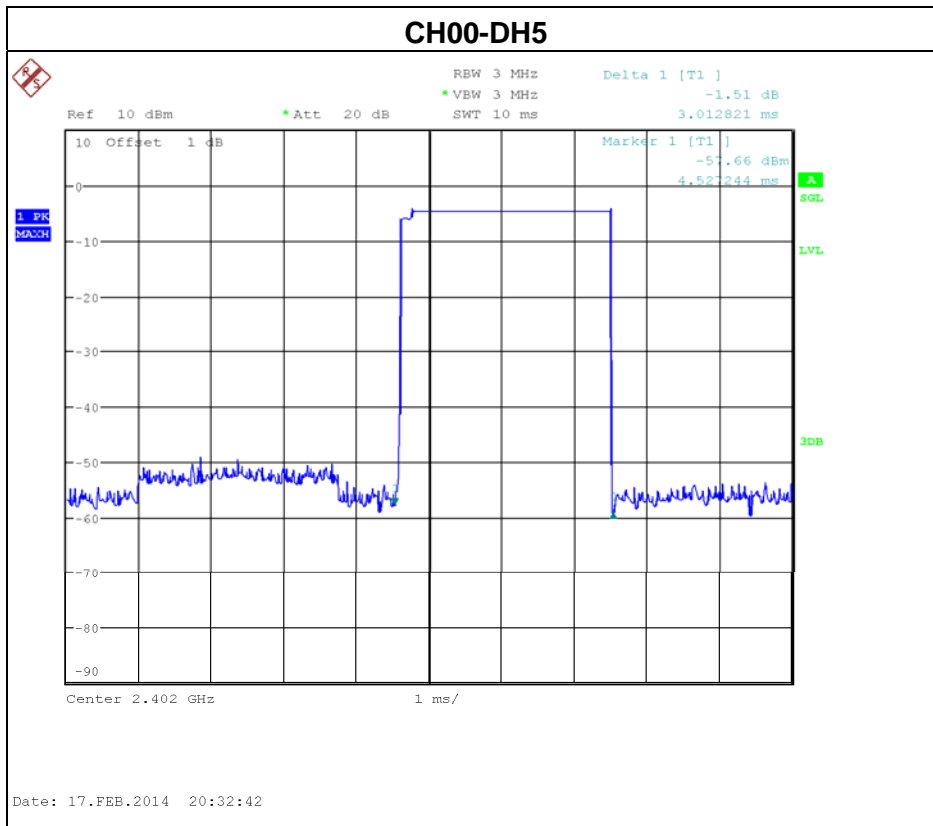

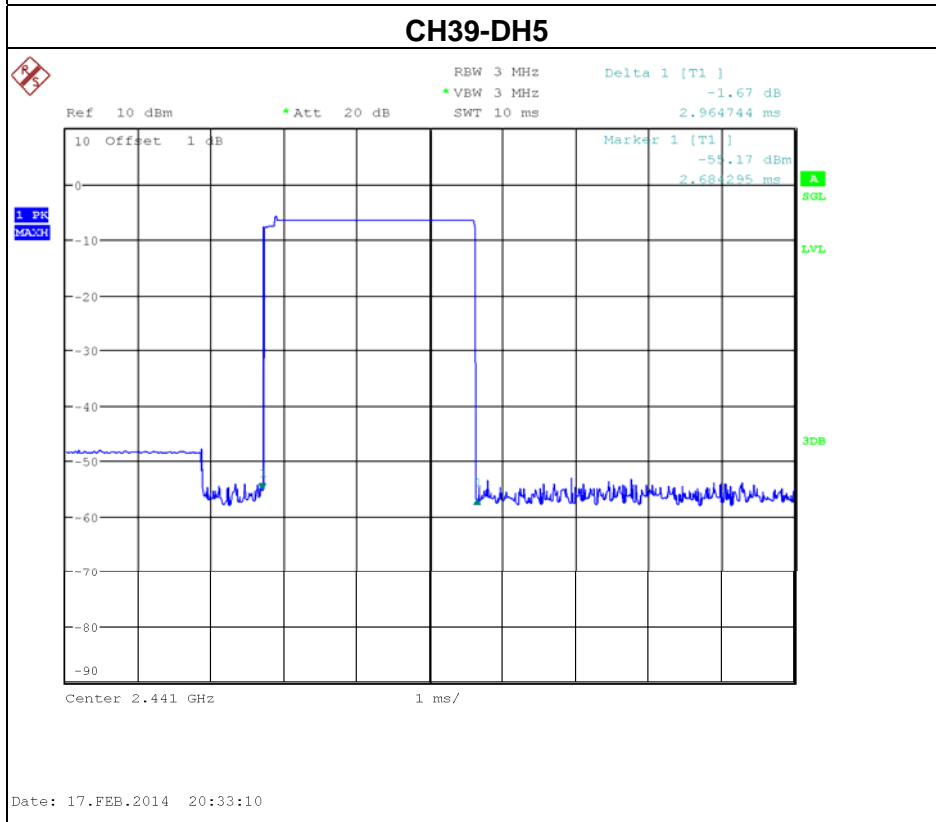
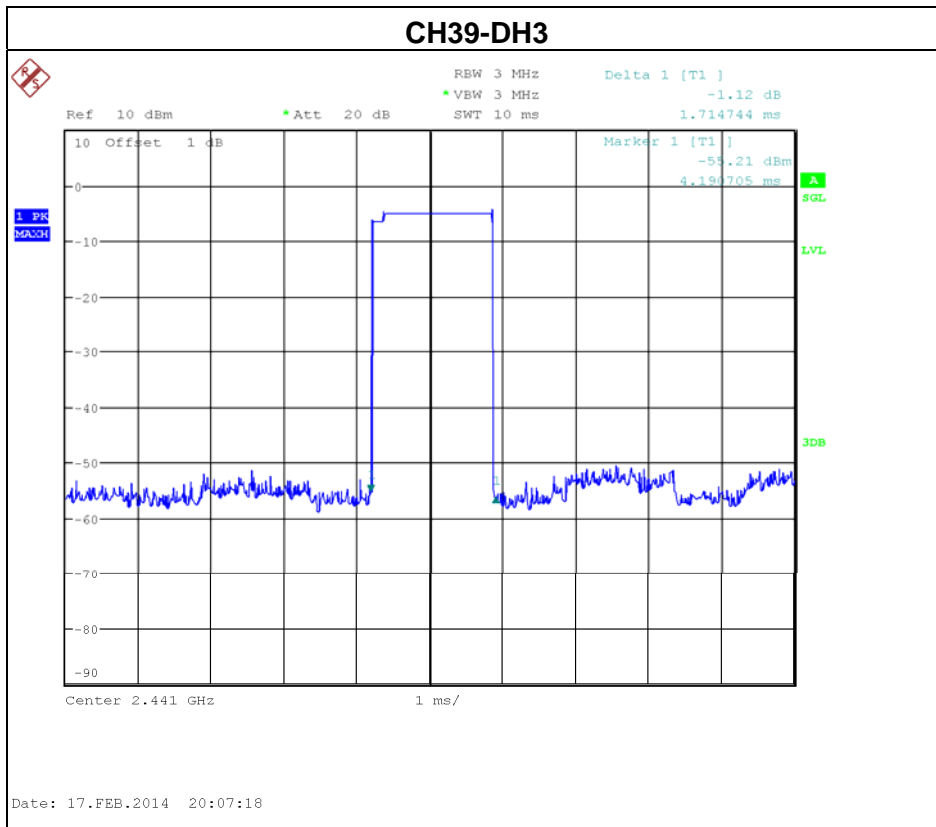

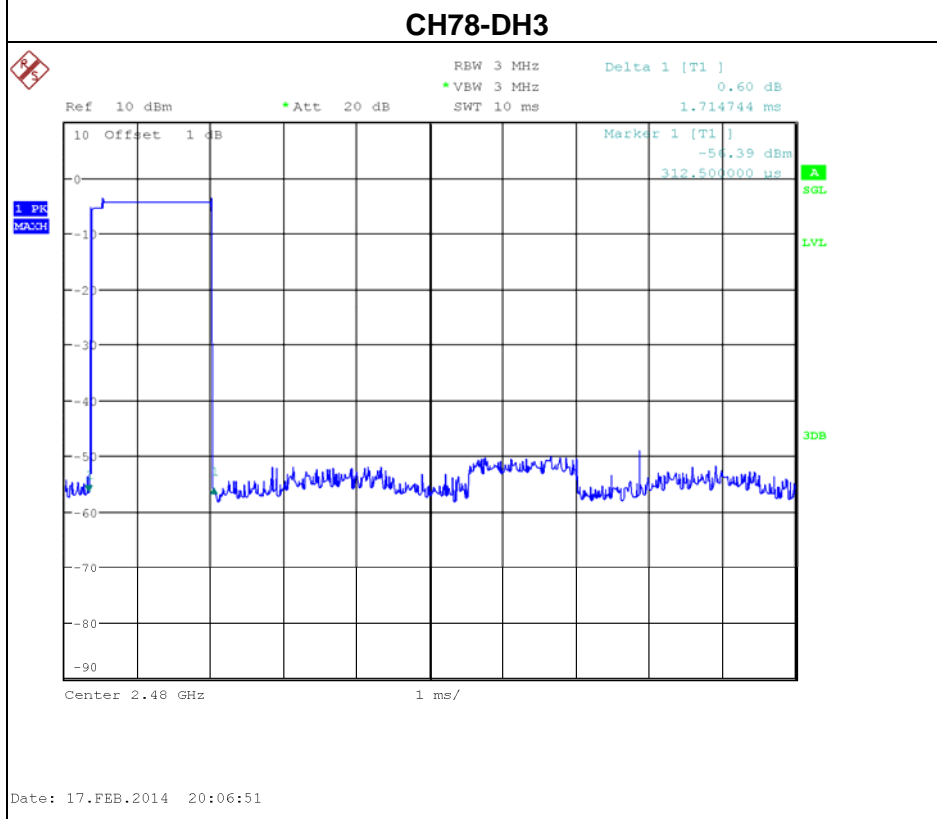
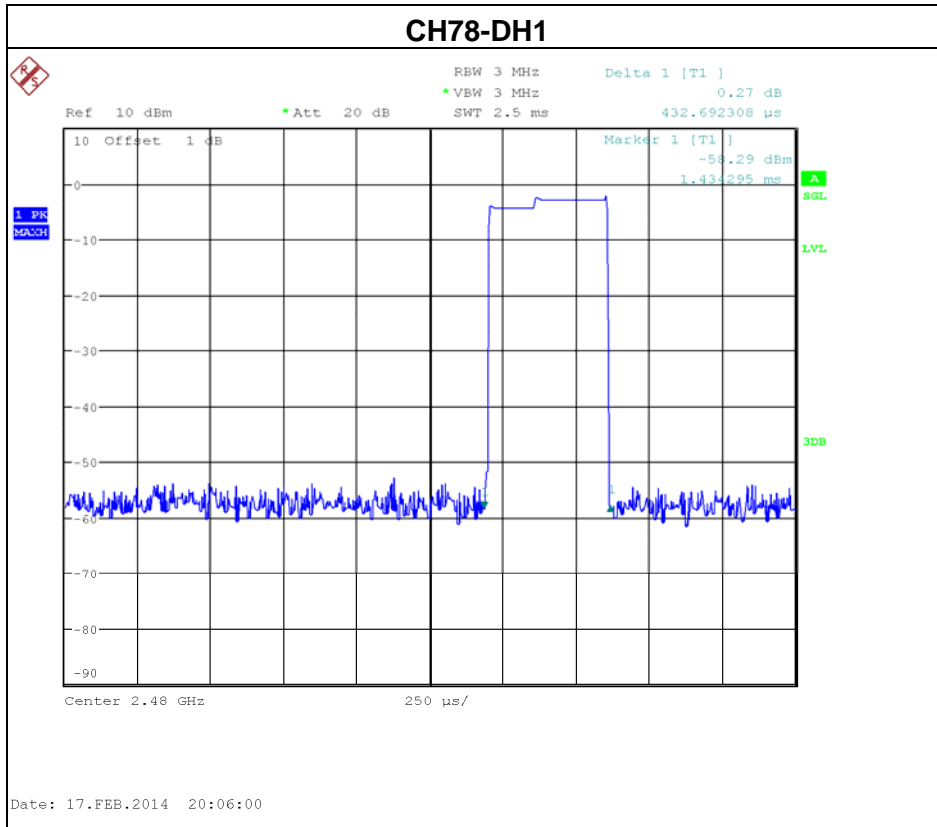

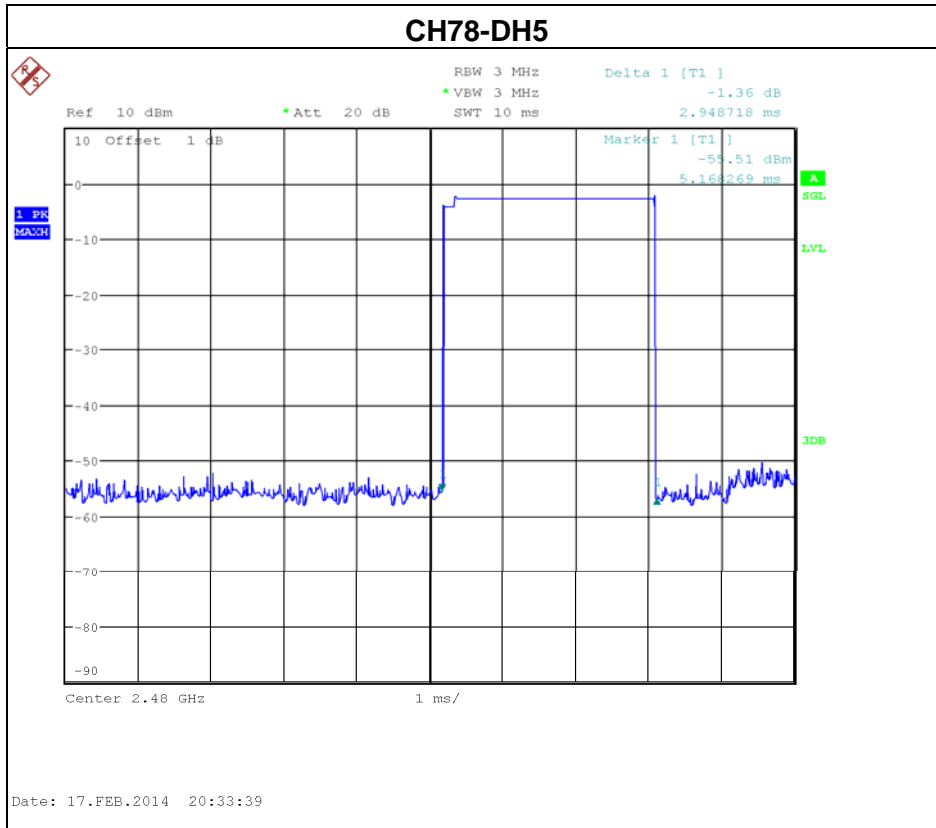

7. HOPPING CHANNEL SEPARATION MEASUREMENT

7.1 APPLIED PROCEDURES / LIMIT

Frequency hopping systems operating in the 2400-2483.5 MHz band may have hopping channel carrier frequencies that are separated by 25 KHz or two-thirds of the 20 dB bandwidth of the hopping channel, whichever is greater.

Spectrum Parameter	Setting
Attenuation	Auto
Span Frequency	> Measurement Bandwidth or Channel Separation
RBW	30 KHz
VBW	100 KHz
Detector	Peak
Trace	Max Hold
Sweep Time	Auto

7.1.1 TEST PROCEDURE

- a. The EUT must have its hopping function enabled
- b. Span = wide enough to capture the peaks of two adjacent channels
 - Resolution (or IF) Bandwidth (RBW) \geq 1% of the span
 - Video (or Average) Bandwidth (VBW) \geq RBW
 - Sweep = Auto
 - Detector function = Peak
 - Trace = Max Hold

7.1.2 DEVIATION FROM STANDARD

No deviation.

7.1.3 TEST SETUP

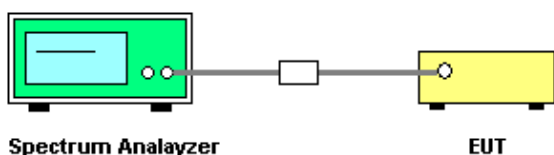

7.1.4 EUT TEST CONDITIONS

Temperature: 25°C
 Relative Humidity: 55%
 Test Voltage: 120V/60Hz



7.1.5 TEST RESULTS

Test Mode: Hopping on_1Mbps			
Frequency (MHz)	Ch. Separation (MHz)	2/3 of the 20 dB bandwidth (MHz)	Result
2402	1.008	0.693	Complies
2441	1.002	0.693	Complies
2480	1.002	0.693	Complies

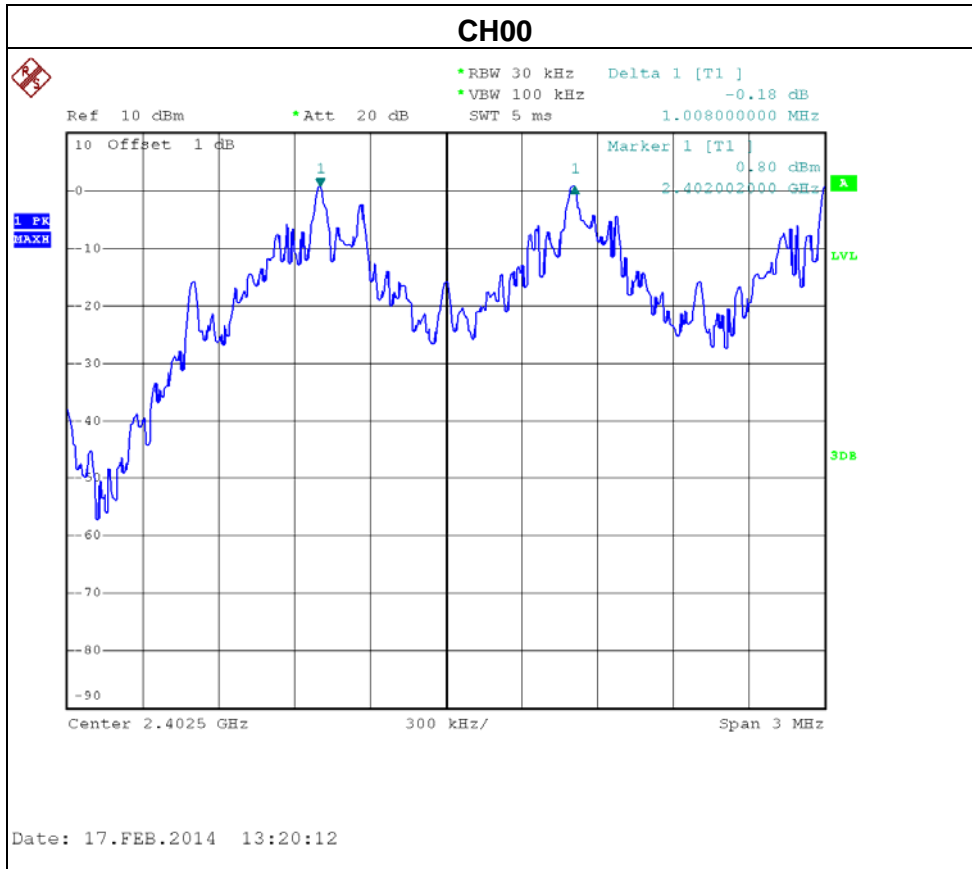

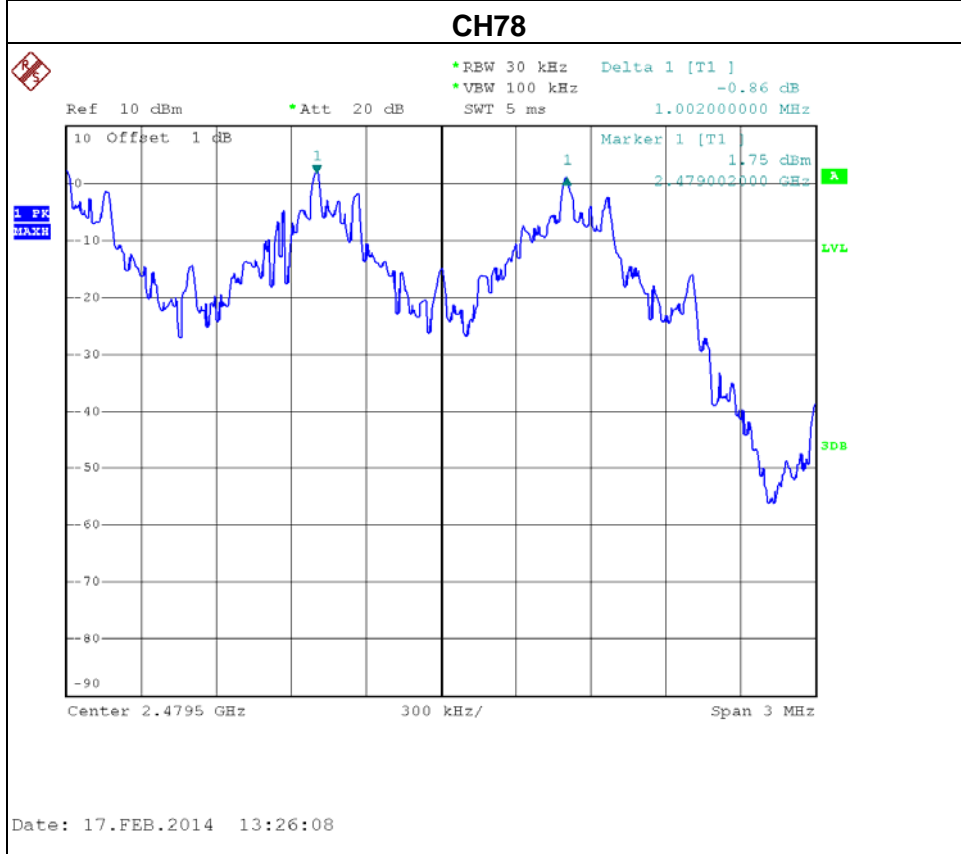
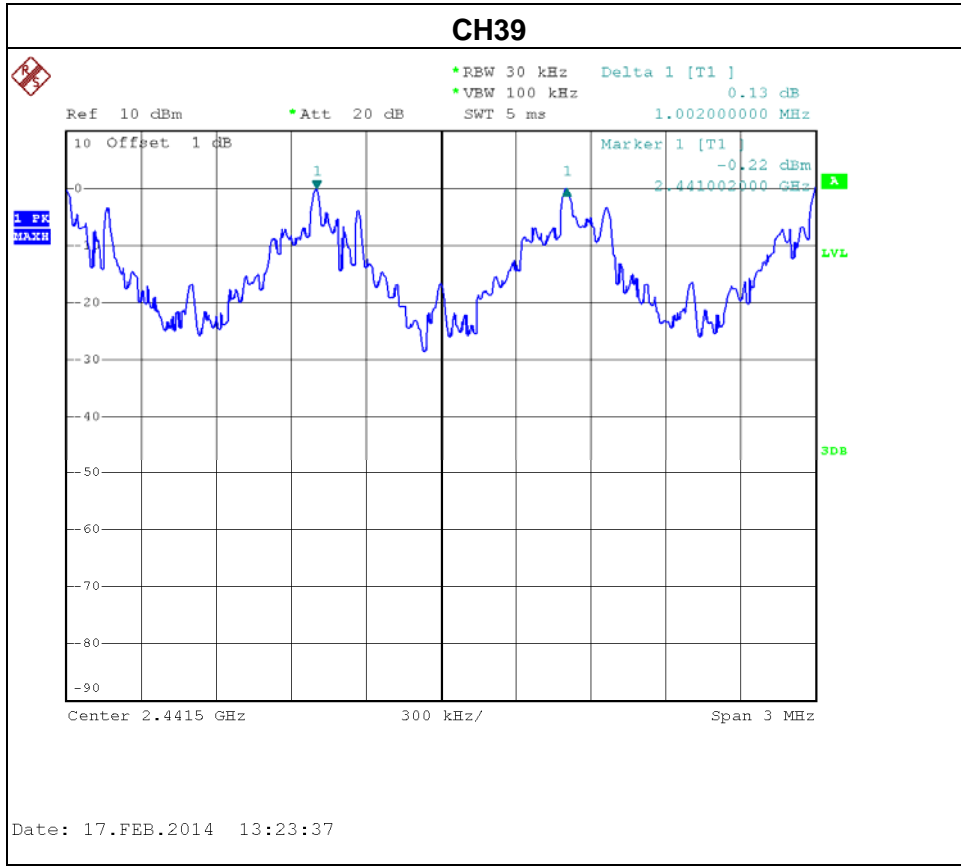



Test Mode: Hopping on_3Mbps			
Frequency (MHz)	Ch. Separation (MHz)	2/3 of the 20 dB bandwidth (MHz)	Result
2402	1.005	0.785	Complies
2441	1.005	0.780	Complies
2480	1.005	0.780	Complies

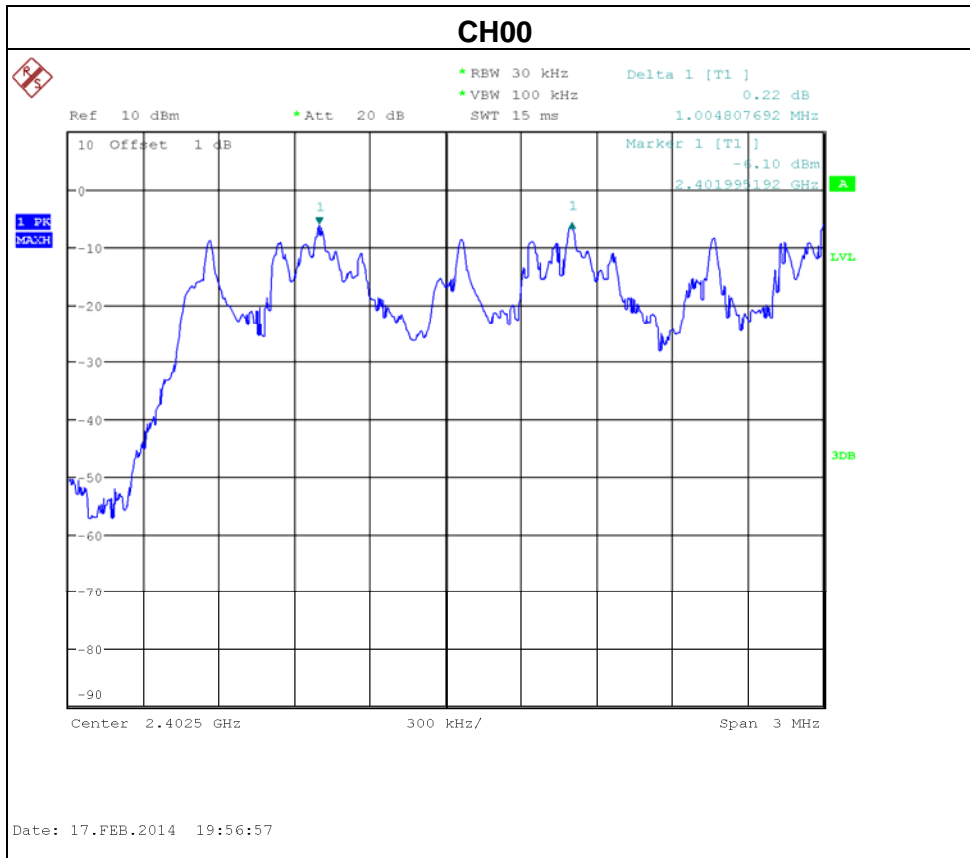

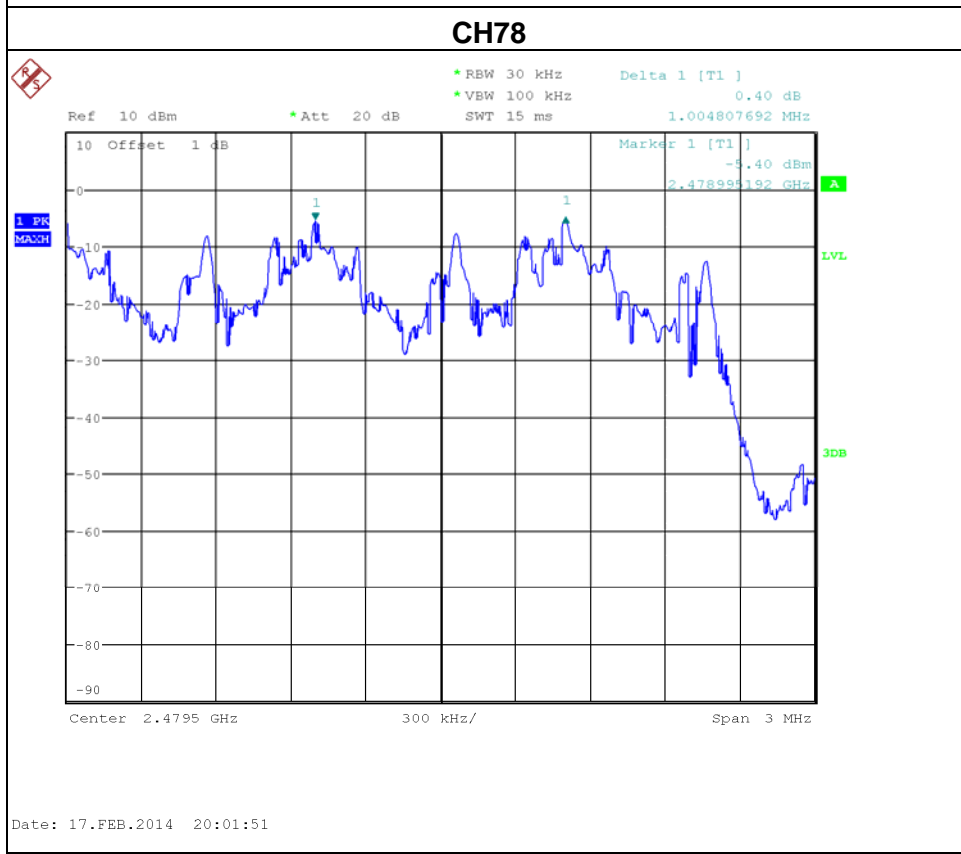
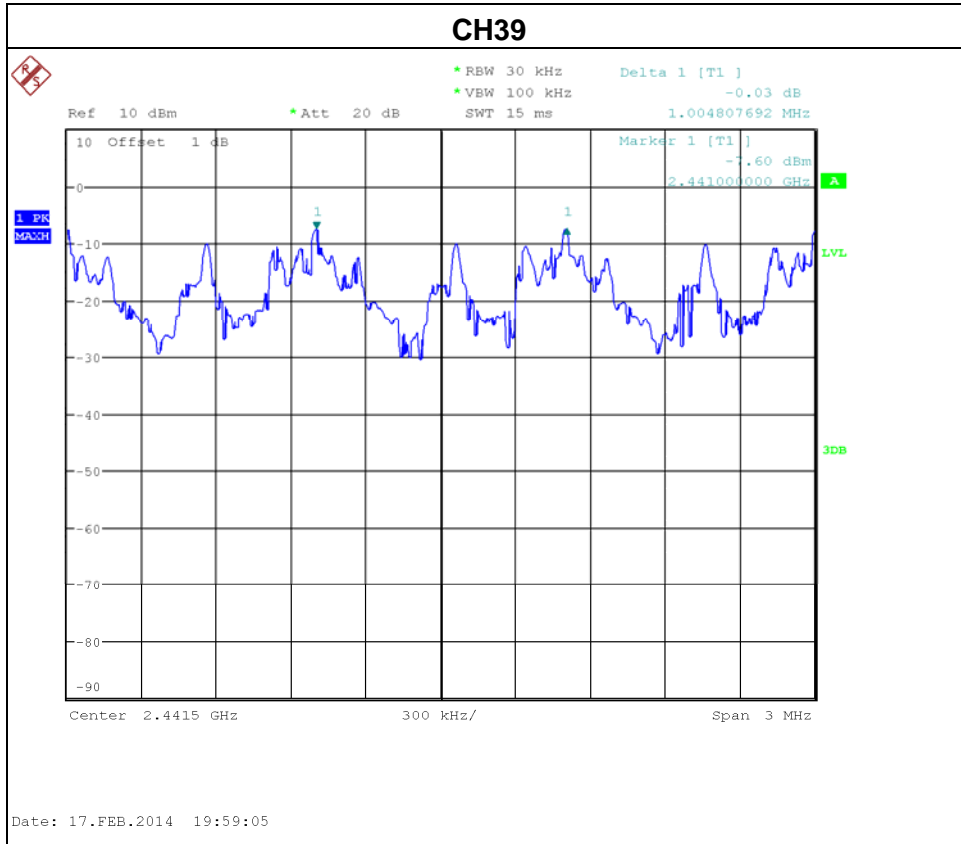



8. BANDWIDTH TEST

8.1 APPLIED PROCEDURES

FCC Part15 (15.247) , Subpart C/ RSS-GEN and RSS-210		
Section	Test Item	Frequency Range (MHz)
15.247(a)(2) RSS-GEN section 4.6.1 RSS-210, Issue 8, Annex 8, A8.1(b)	Bandwidth	2400-2483.5

Spectrum Parameter	Setting
Attenuation	Auto
Span Frequency	> Measurement Bandwidth or Channel Separation
RBW	30 KHz (20dB Bandwidth) / 30 KHz (Channel Separation)
VBW	100 KHz (20dB Bandwidth) / 100 KHz (Channel Separation)
Detector	Peak
Trace	Max Hold
Sweep Time	Auto

8.1.1 TEST PROCEDURE

- a. The EUT was directly connected to the spectrum analyzer and antenna output port as show in the block diagram below,
- b. Spectrum Setting: RBW= 30KHz, VBW=100KHz, Sweep Time = Auto.

8.1.2 DEVIATION FROM STANDARD

No deviation.

8.1.3 TEST SETUP

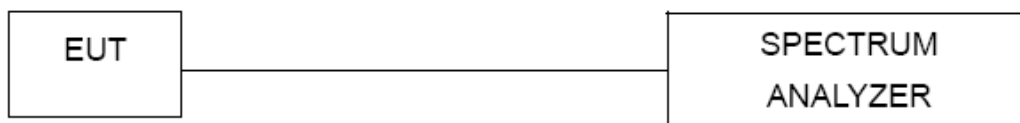

8.1.4 EUT OPERATION CONDITIONS

The EUT tested system was configured as the statements of 4.1.5 Unless otherwise a special operating condition is specified in the follows during the testing.

8.1.5 EUT TEST CONDITIONS

Temperature: 25°C
 Relative Humidity: 55%
 Test Voltage: 120V/60Hz



8.1.6 TEST RESULTS

Test Mode: 1Mbps				
Test Channel	Frequency (MHz)	20dB Bandwidth (MHz)	99% Occupied Bandwidth (MHz)	Result
CH00	2402	1.04	0.99	PASS
CH39	2441	1.04	0.99	PASS
CH78	2480	1.04	0.90	PASS

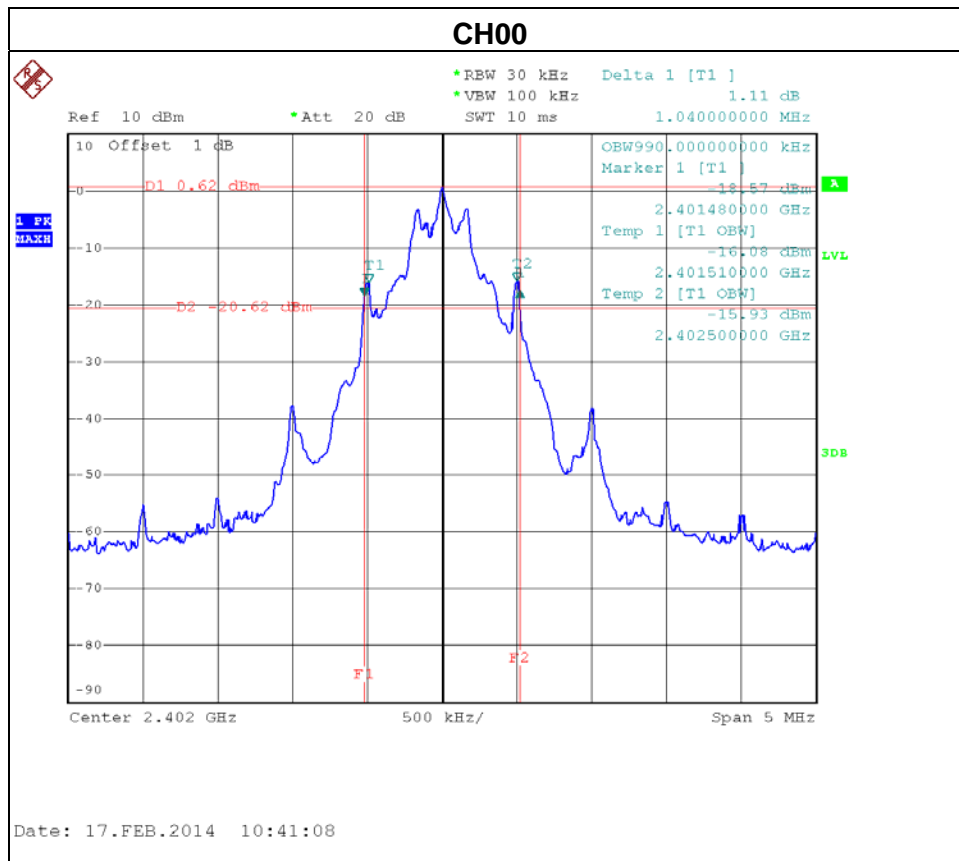

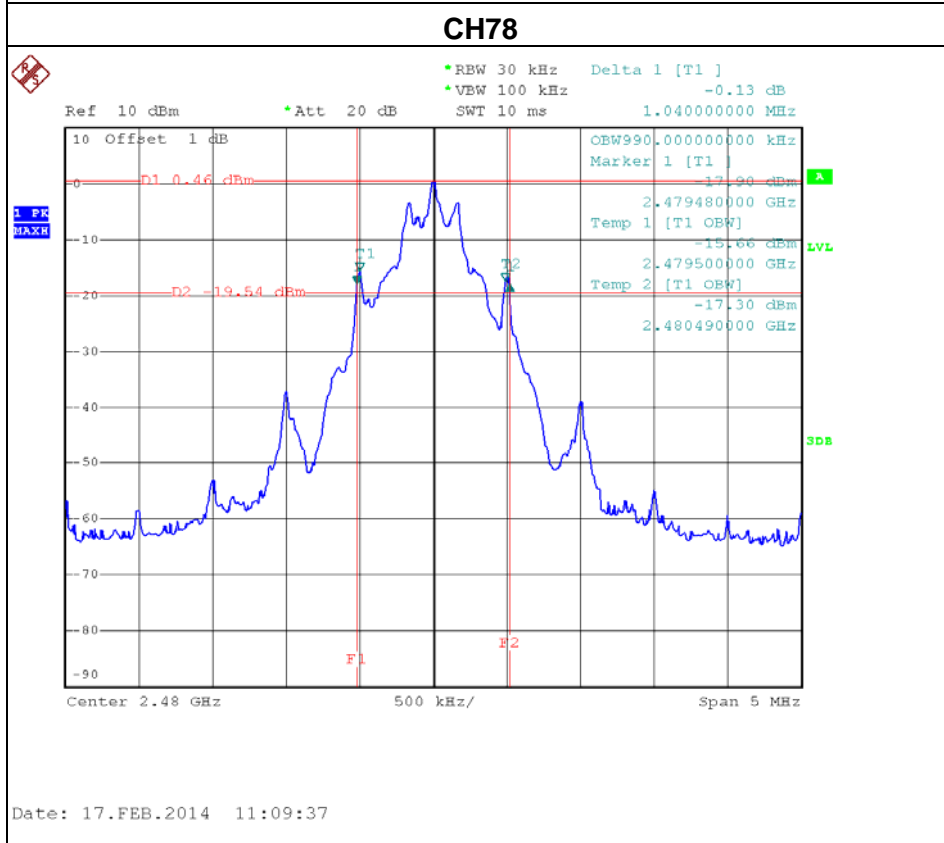
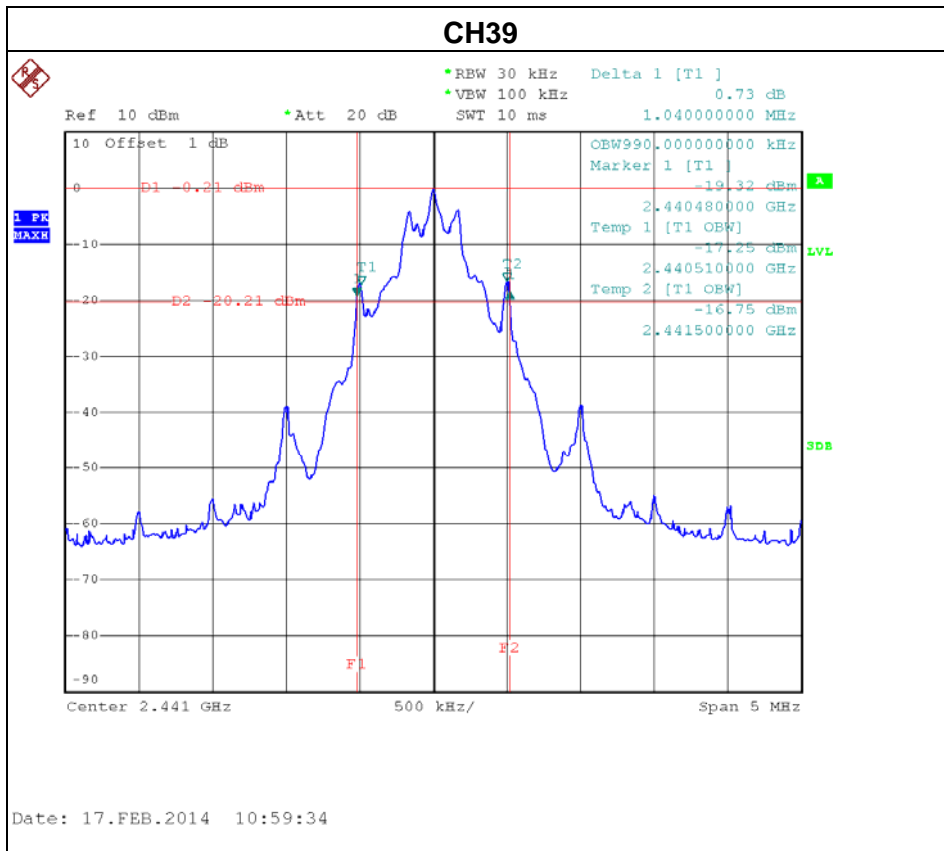



Test Mode: 3Mbps

Test Channel	Frequency (MHz)	20dB Bandwidth (MHz)	99% Occupied Bandwidth (MHz)	Result
CH00	2402	1.178	1.130	PASS
CH39	2441	1.170	1.122	PASS
CH78	2480	1.170	1.122	PASS

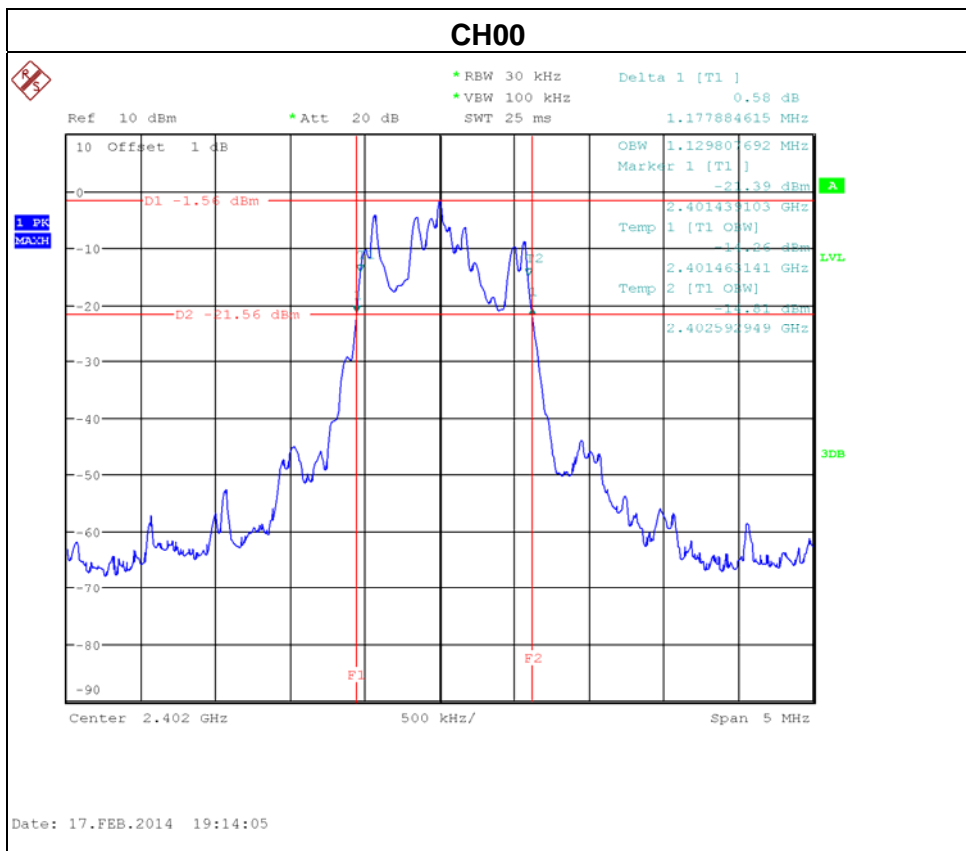

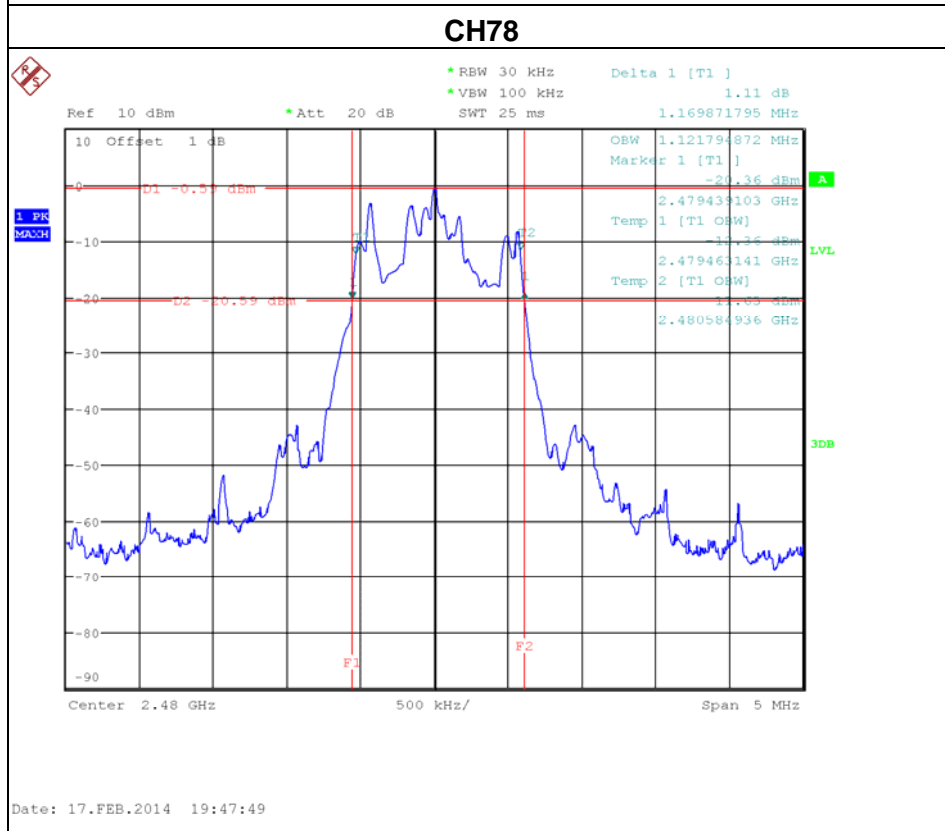
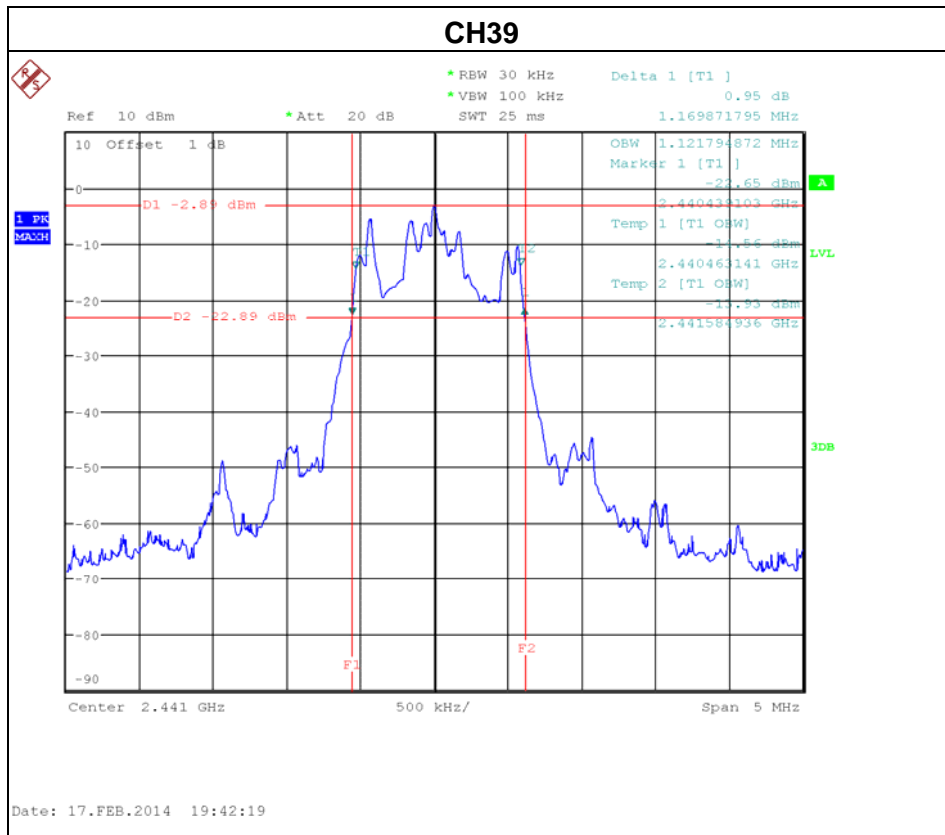



9. PEAK OUTPUT POWER TEST

9.1 APPLIED PROCEDURES / LIMIT

FCC Part15 (15.247) , Subpart C/ RSS-GEN and RSS-210				
Section	Test Item	Limit	Frequency Range (MHz)	Result
15.247(b)(1) RSS-GEN section 4.8 RSS-210, Issue 8, Annex 8, A8.1(b)	Peak Output Power	0.125 Watt or 21dBm	2400-2483.5	PASS

9.1.1 TEST PROCEDURE

- a. The EUT was directly connected to the spectrum analyzer and antenna output port as show in the block diagram below,
- b. Spectrum Setting: RBW= 1MHz/3MHz, VBW= 1MHz/3MHz, Sweep time = Auto.

9.1.2 DEVIATION FROM STANDARD

No deviation.

9.1.3 TEST SETUP



9.1.4 EUT OPERATION CONDITIONS

The EUT tested system was configured as the statements of 4.1.5 Unless otherwise a special operating condition is specified in the follows during the testing.

9.1.5 EUT TEST CONDITIONS

Temperature: 25°C
 Relative Humidity: 55%
 Test Voltage: 120V/60Hz



9.1.6 TEST RESULTS

Test Mode: 1Mbps				
Test Channel	Frequency (MHz)	Peak Output Power (dBm)	Limit (dBm)	Limit (Watt)
CH00	2402	0.69	21	0.125
CH39	2441	-0.23	21	0.125
CH78	2480	0.67	21	0.125

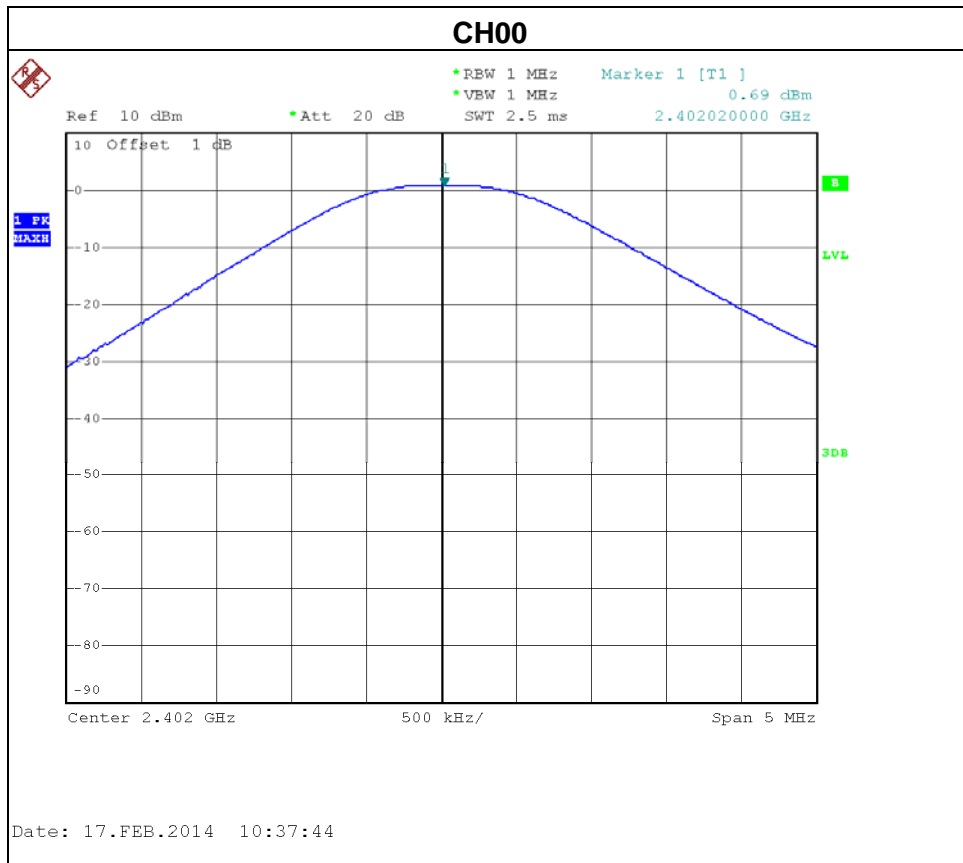

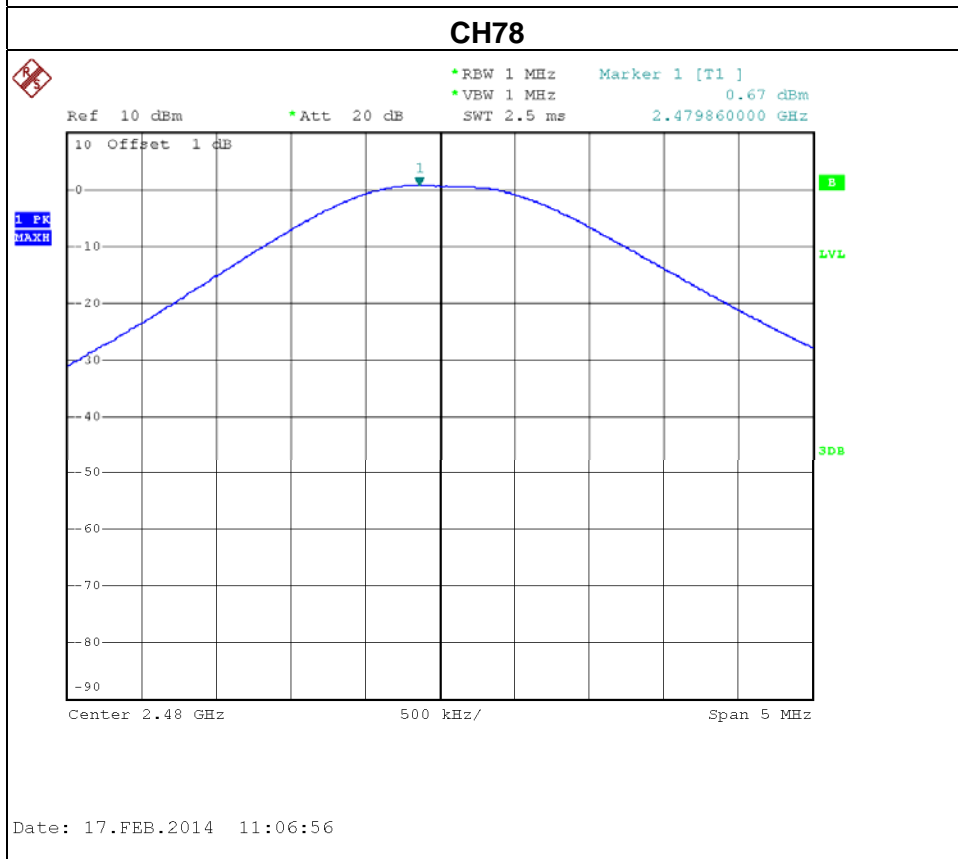
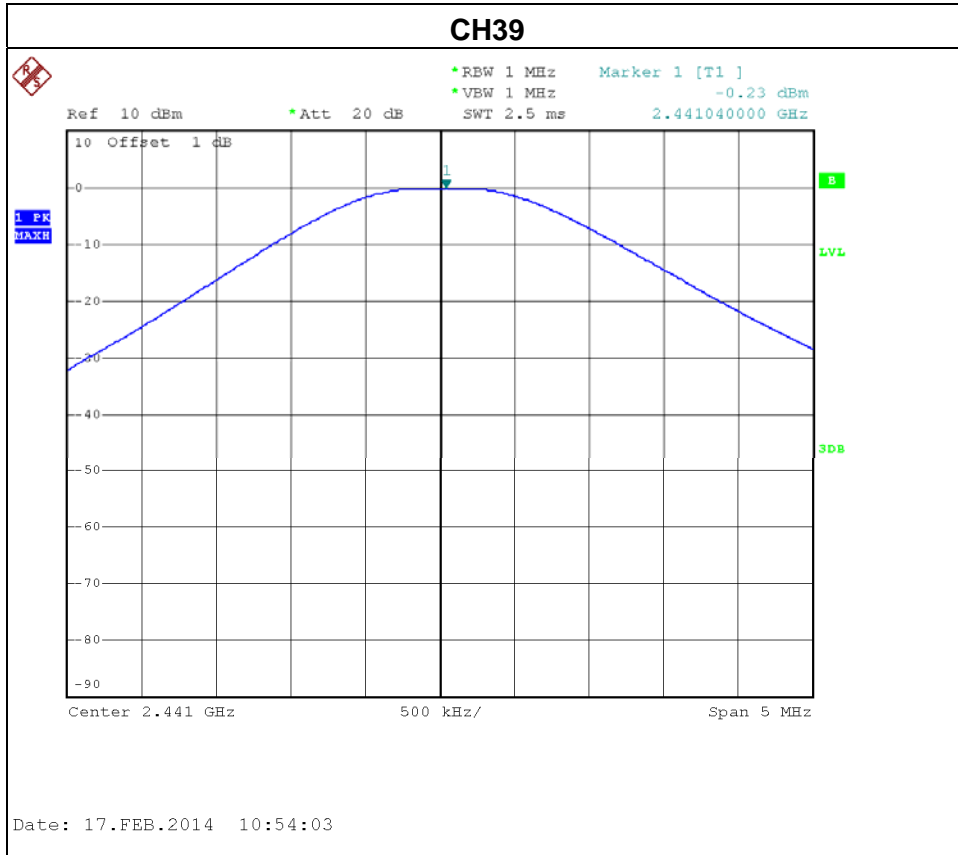



Test Mode: 3Mbps

Test Channel	Frequency (MHz)	Peak Output Power (dBm)	Limit (dBm)	Limit (Watt)
CH00	2402	1.44	21	0.125
CH39	2441	0.19	21	0.125
CH78	2480	2.36	21	0.125

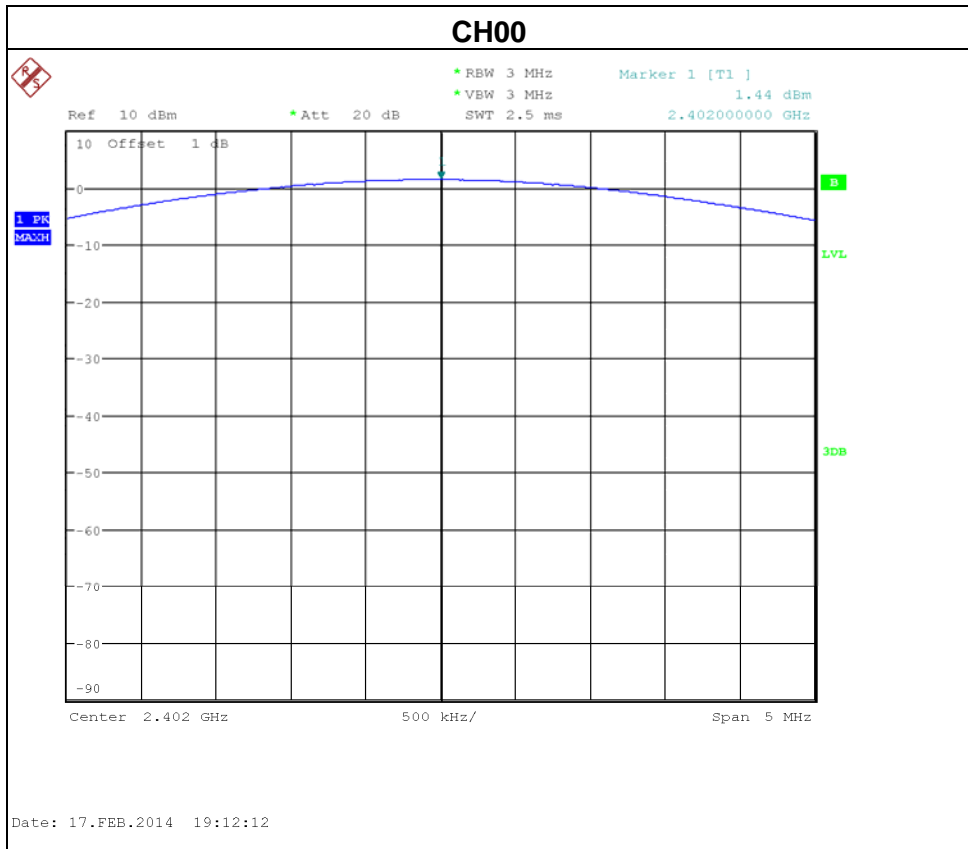

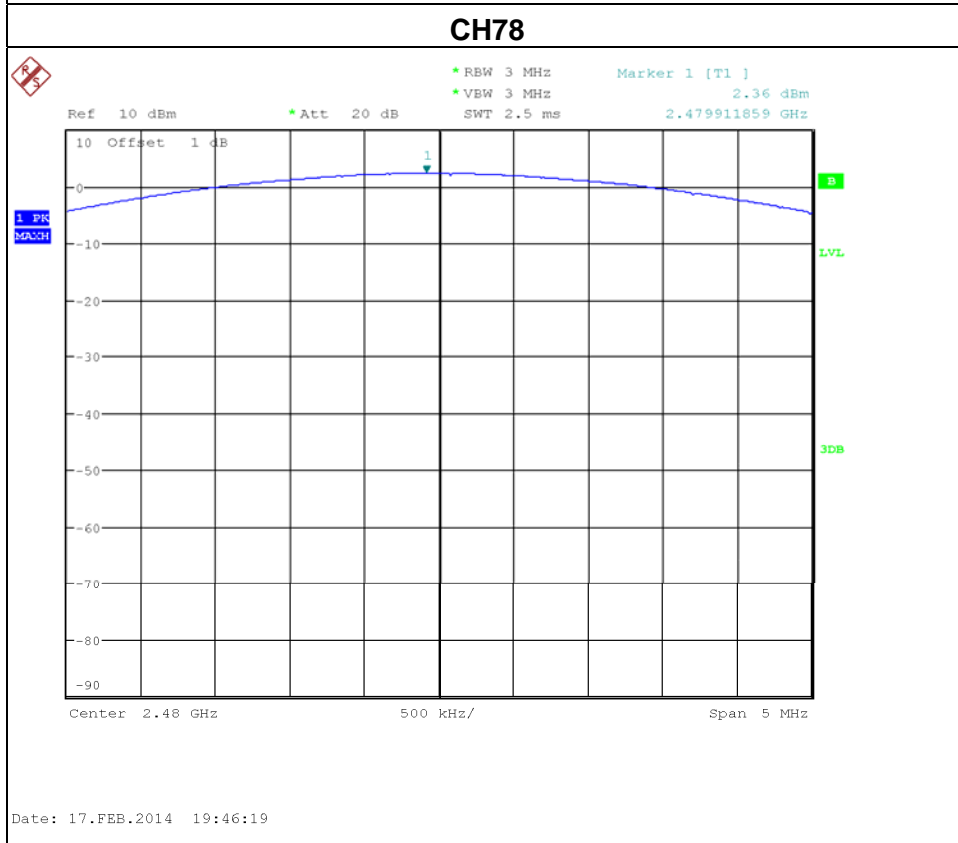
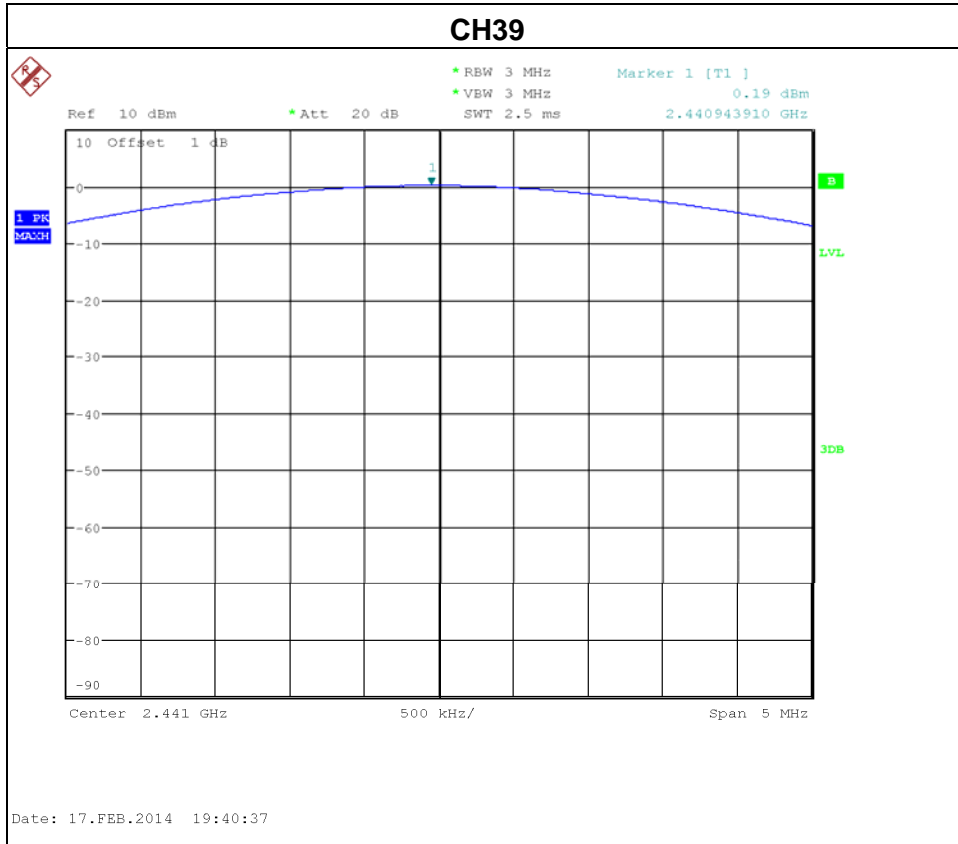



10. ANTENNA CONDUCTED SPURIOUS EMISSION

10.1 APPLIED PROCEDURES / LIMIT

20dB in any 100 KHz bandwidth outside the operating frequency band, In case the emission fall within the restricted band specified on 15.205(a) & RSS-210 section 2.2& Annex 8, A8.5, then the 15.209(a) & RSS-GEN limit in the table below has to be followed.

Frequency (MHz)	Field Strength (microvolts/meter)	Measurement Distance (meters)
0.009~0.490	2400/F(KHz)	300
0.490~1.705	24000/F(KHz)	30
1.705~30.0	30	30
30~88	100	3
88~216	150	3
216~960	200	3
960~1000	500	3

LIMITS OF RADIATED EMISSION MEASUREMENT (Above 1000MHz)

Frequency (MHz)	(dBuV/m) (at 3 meters)	
	Peak	Average
Above 1000	74	54

10.1.1 TEST PROCEDURE

- a. The EUT was directly connected to the spectrum analyzer and antenna output port as show in the block diagram below,
- b. Spectrum Setting: RBW= 100KHz, VBW=100KHz, Sweep time = Auto.

10.1.2 DEVIATION FROM STANDARD

No deviation.



10.1.3 TEST SETUP

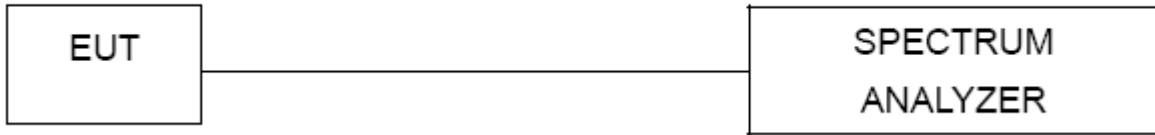

10.1.4 EUT OPERATION CONDITIONS

The EUT tested system was configured as the statements of 4.1.5 Unless otherwise a special operating condition is specified in the follows during the testing.

10.1.5 EUT TEST CONDITIONS

- Temperature: 25°C
- Relative Humidity: 55%
- Test Voltage: 120V/60Hz



10.1.6 TEST RESULTS

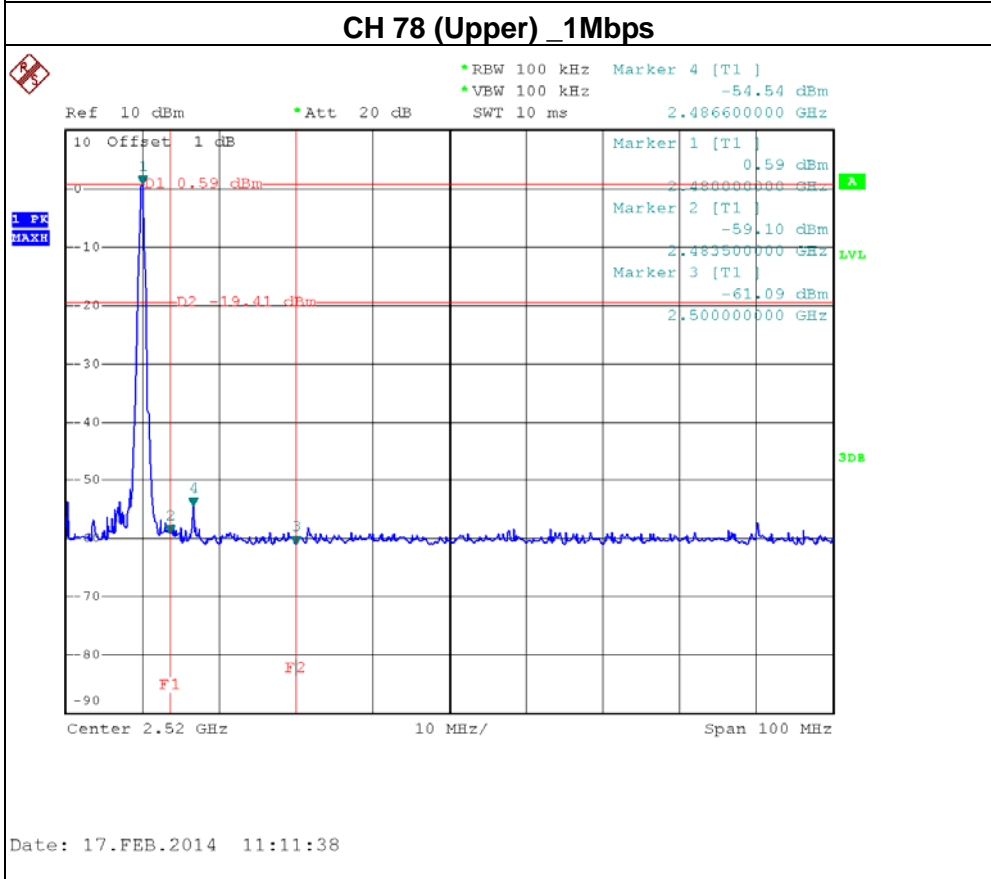
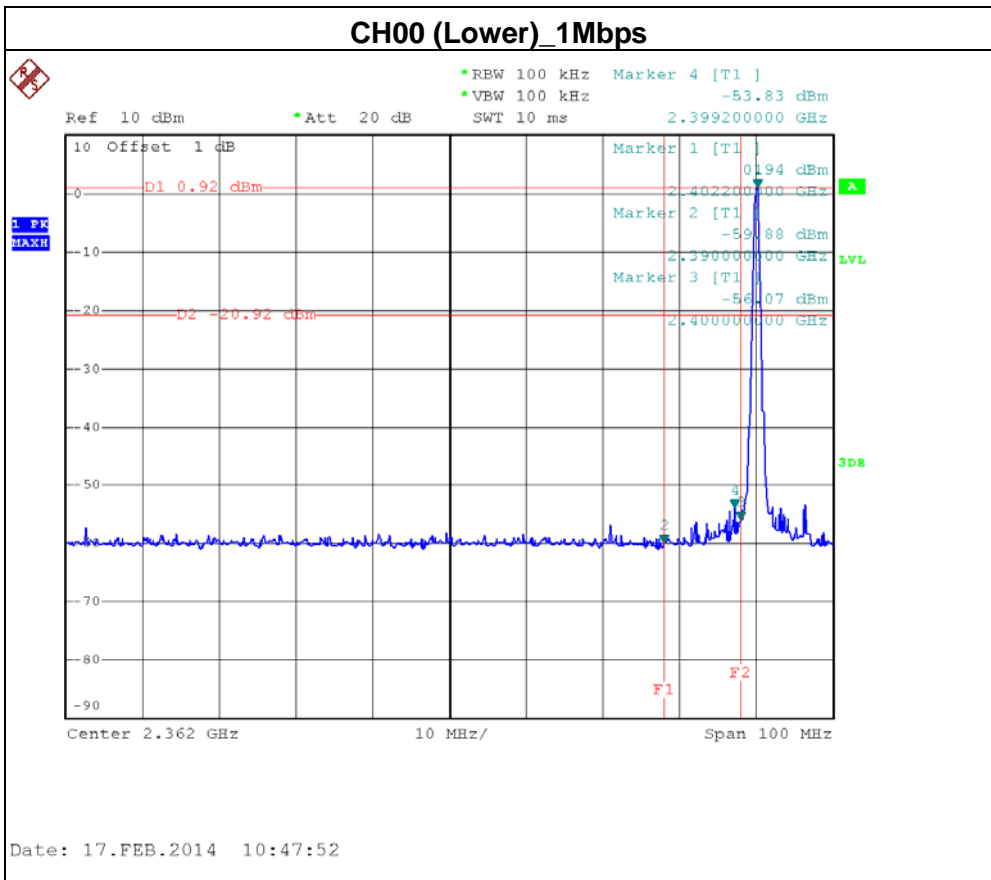

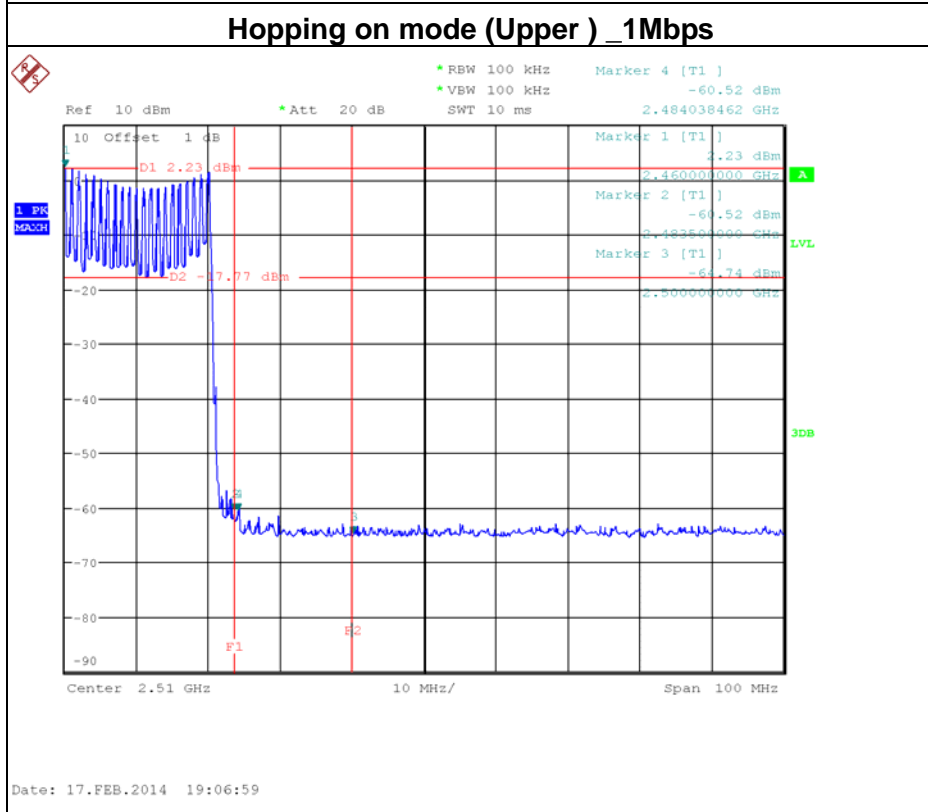
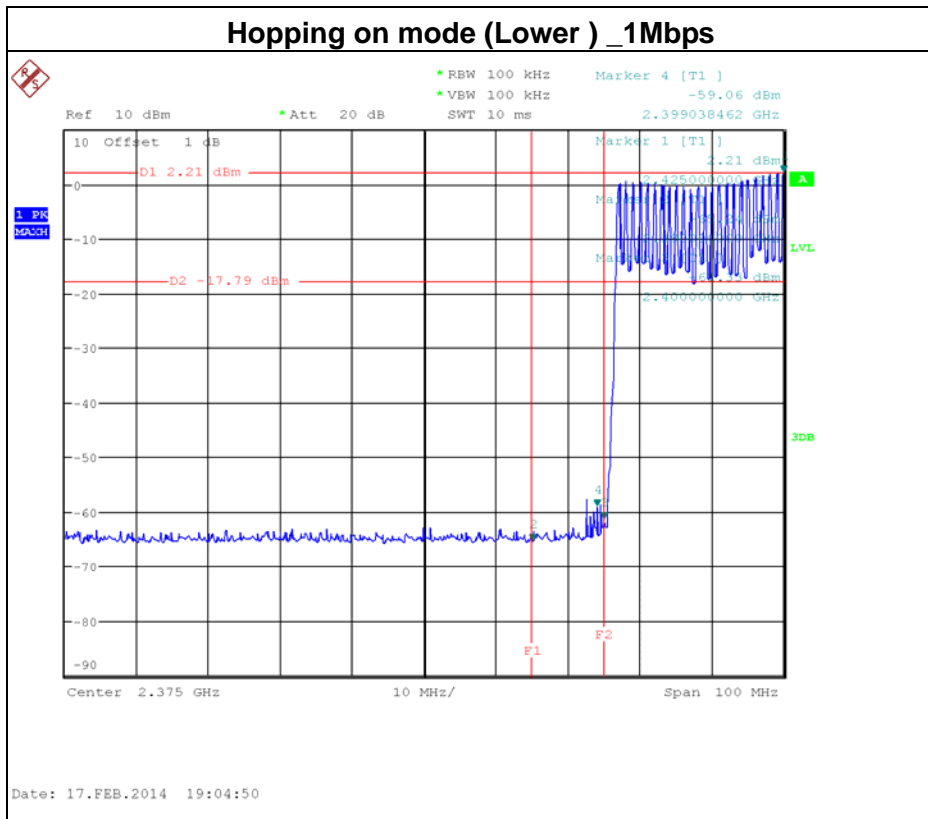

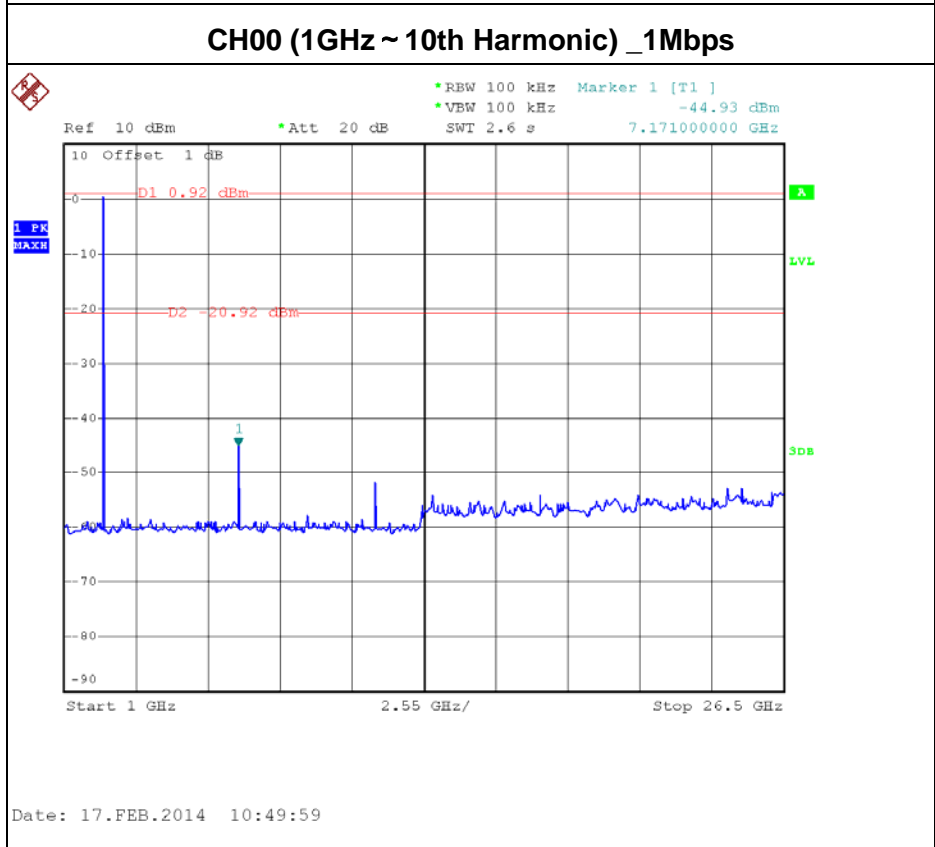
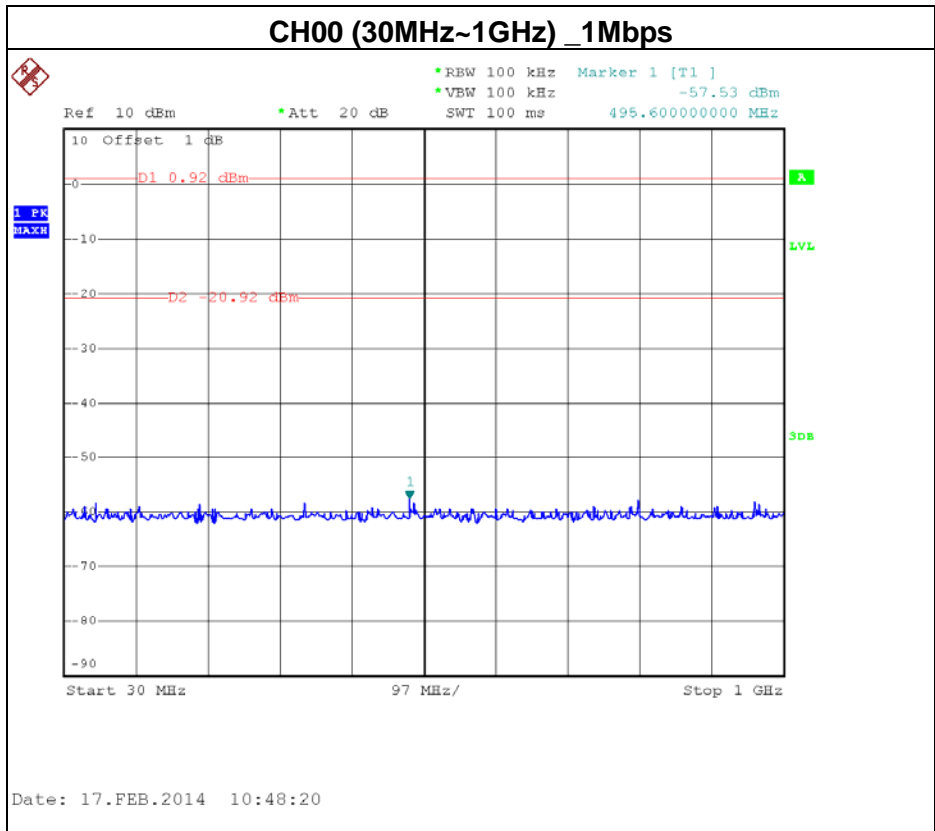

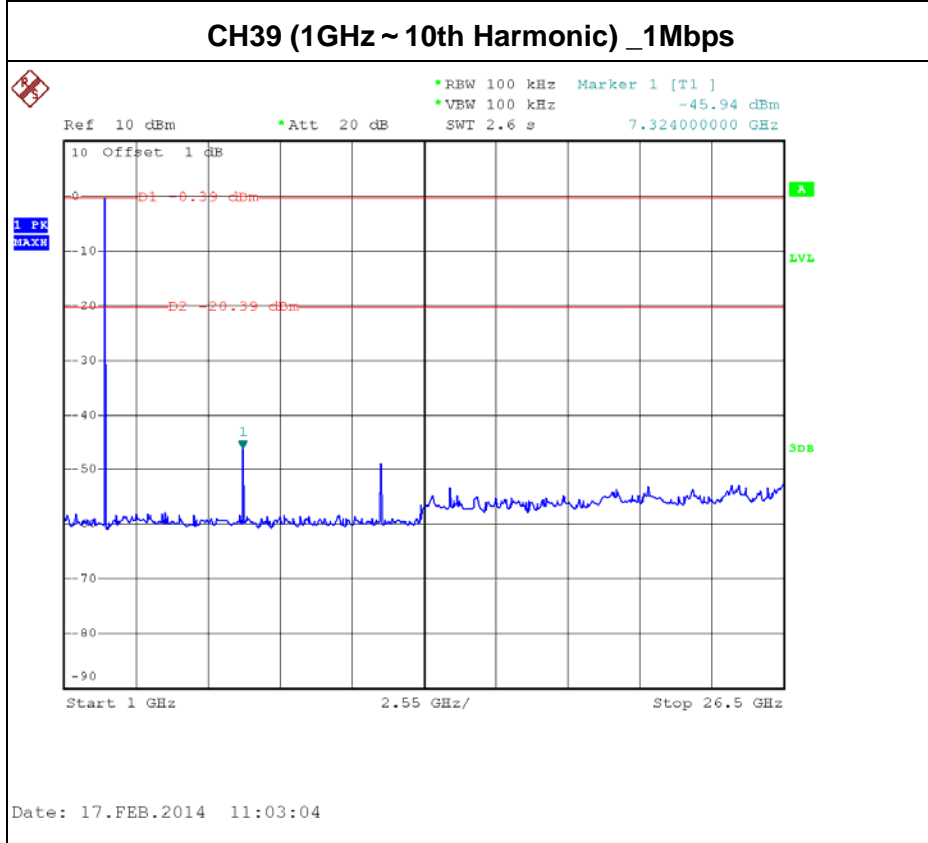
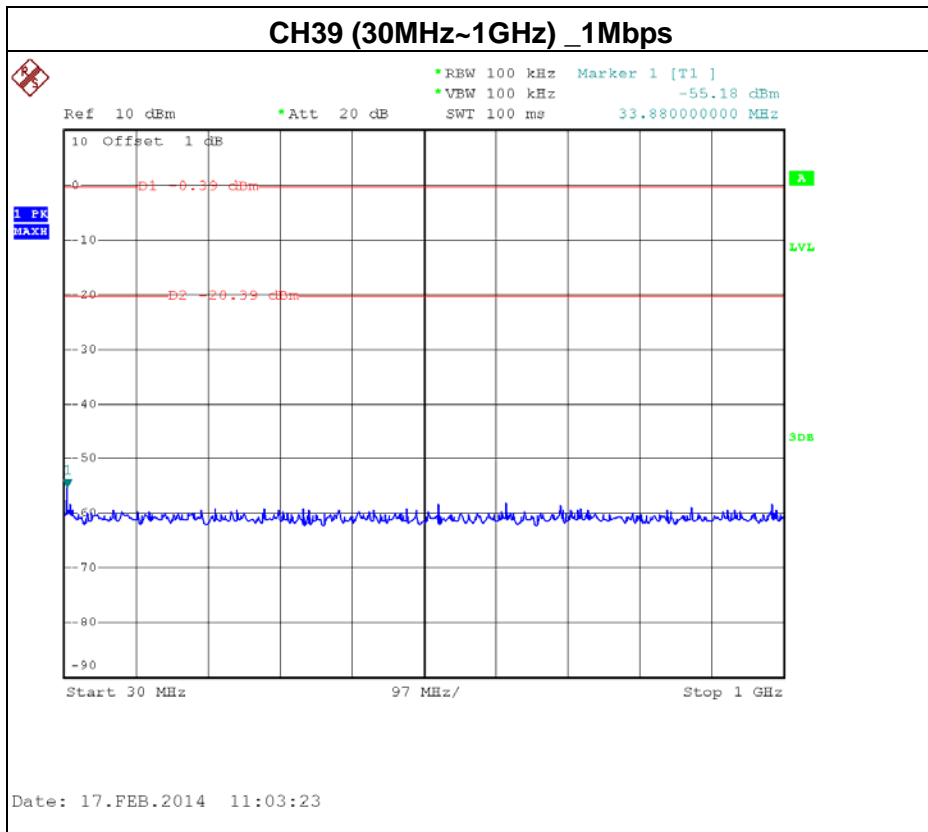

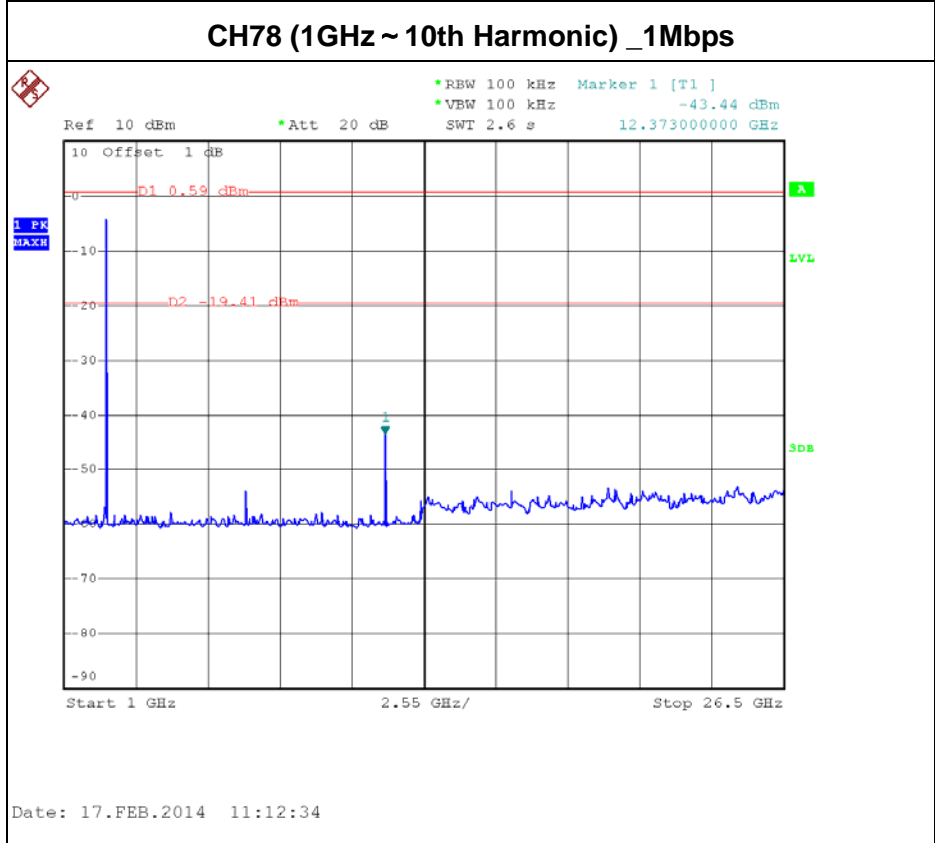
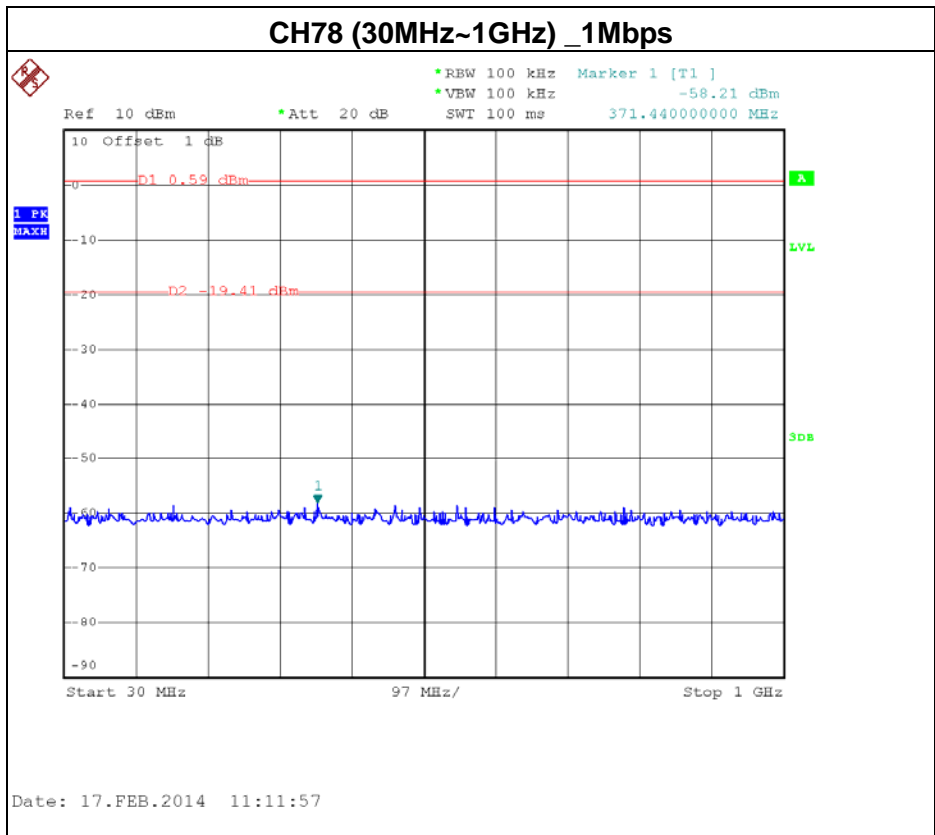

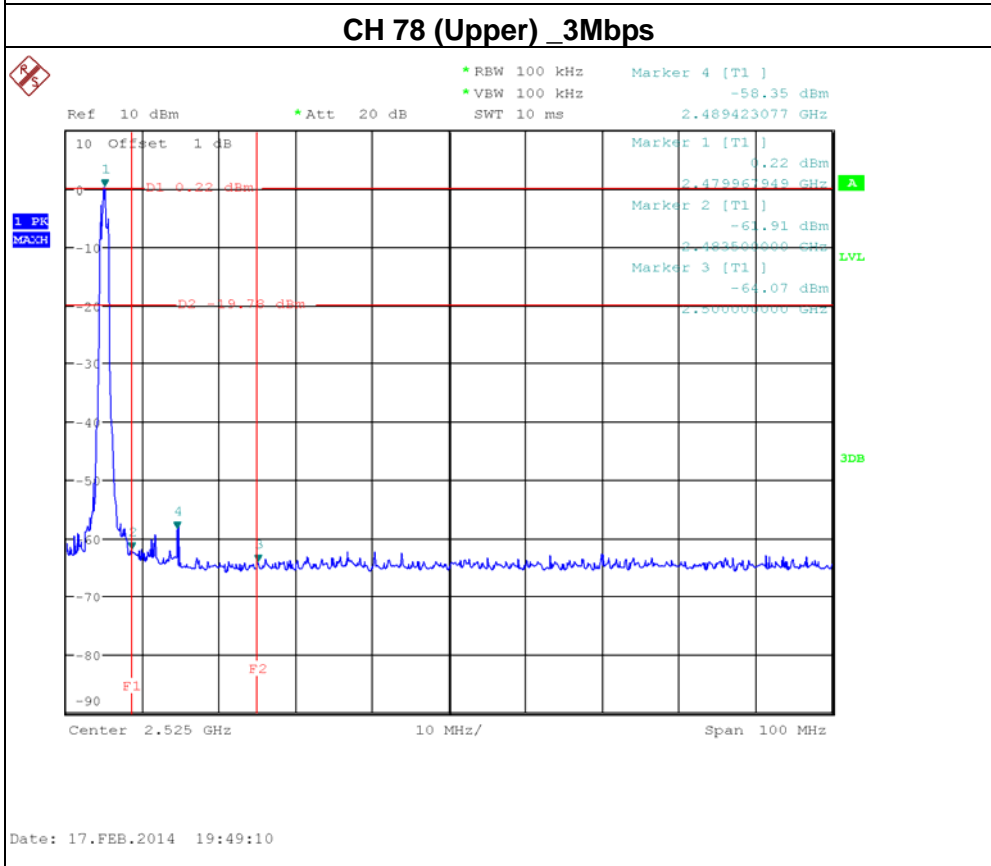
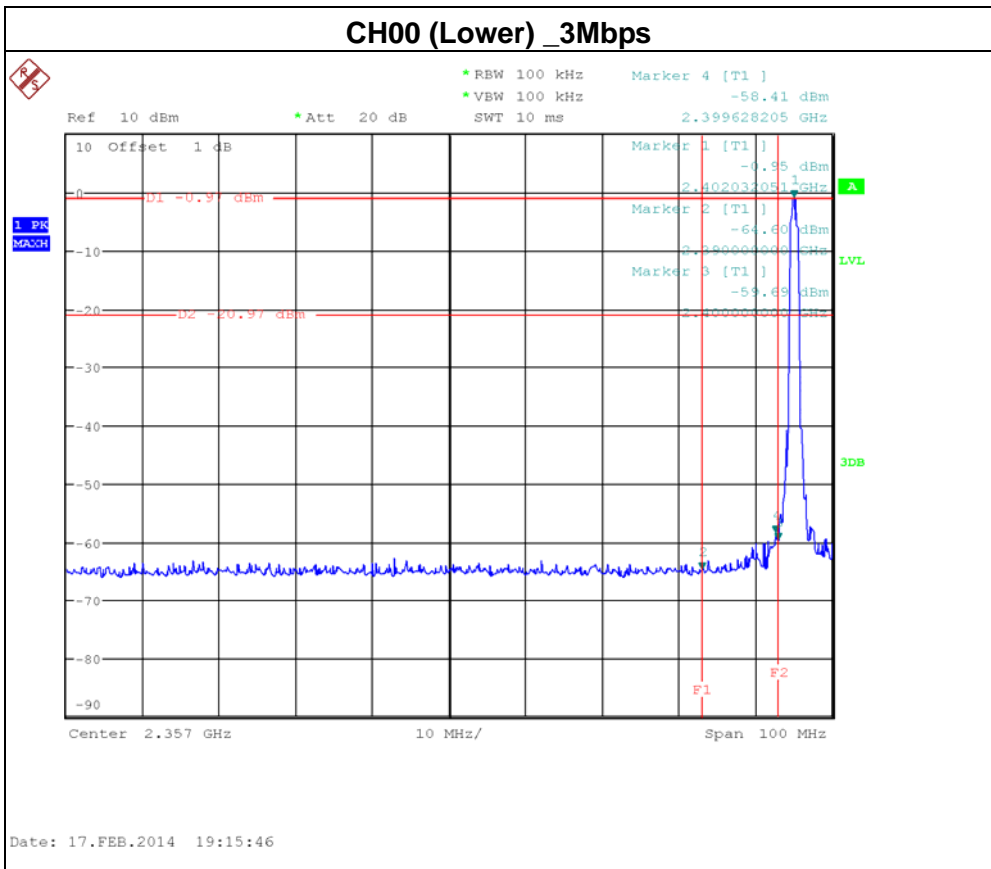

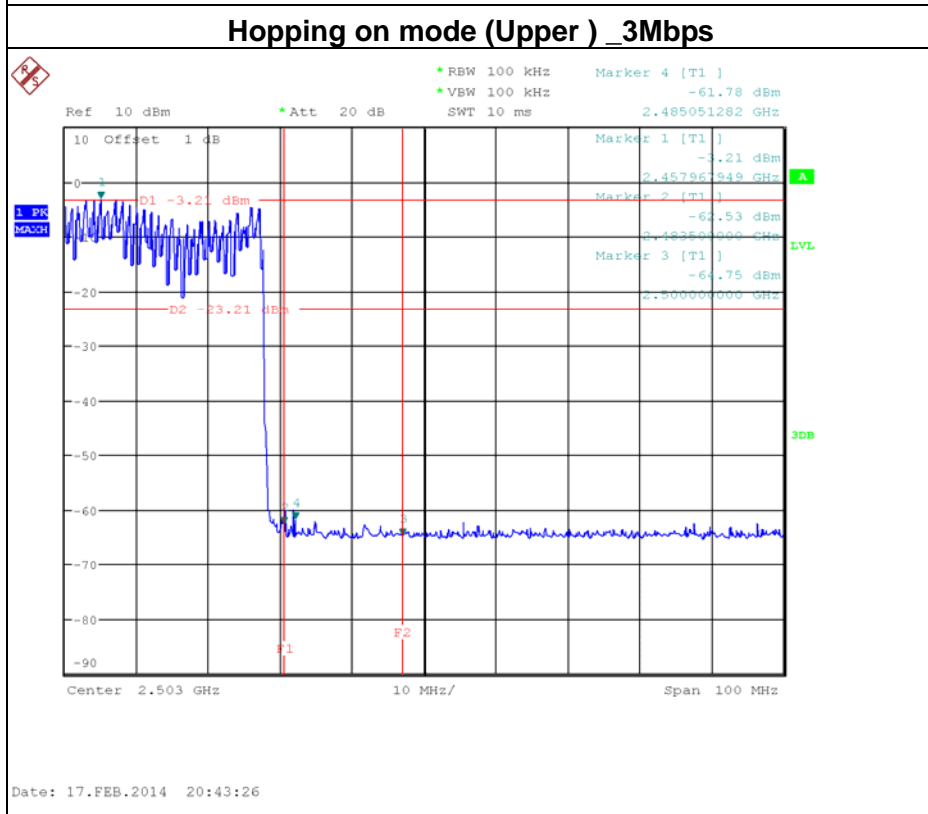
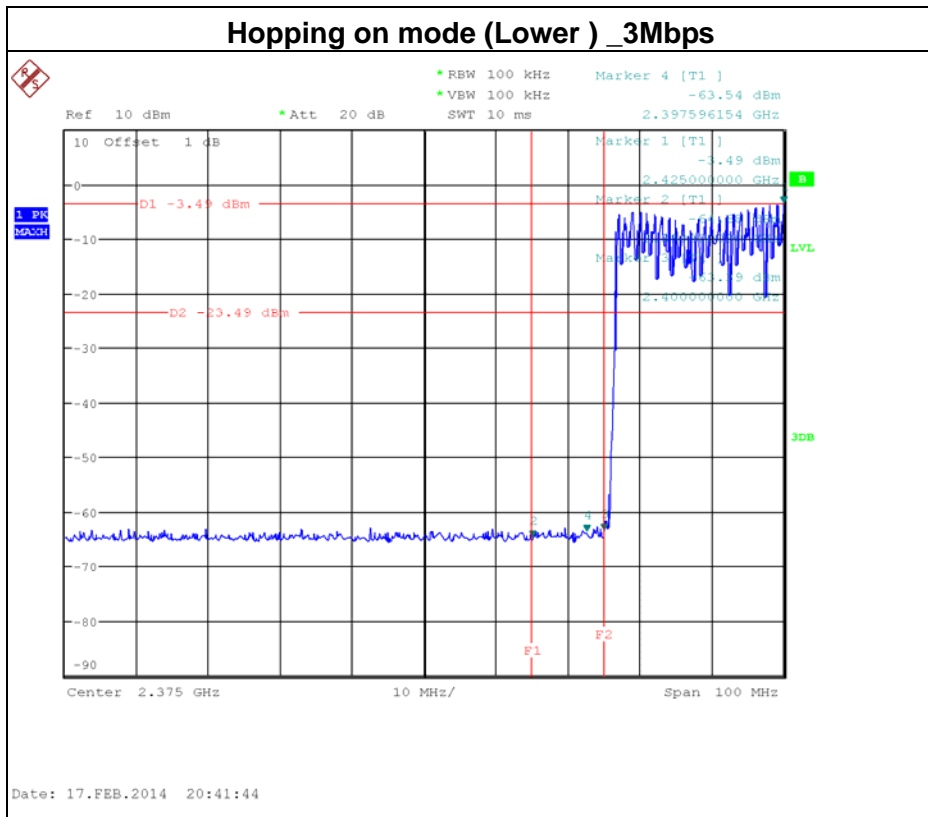

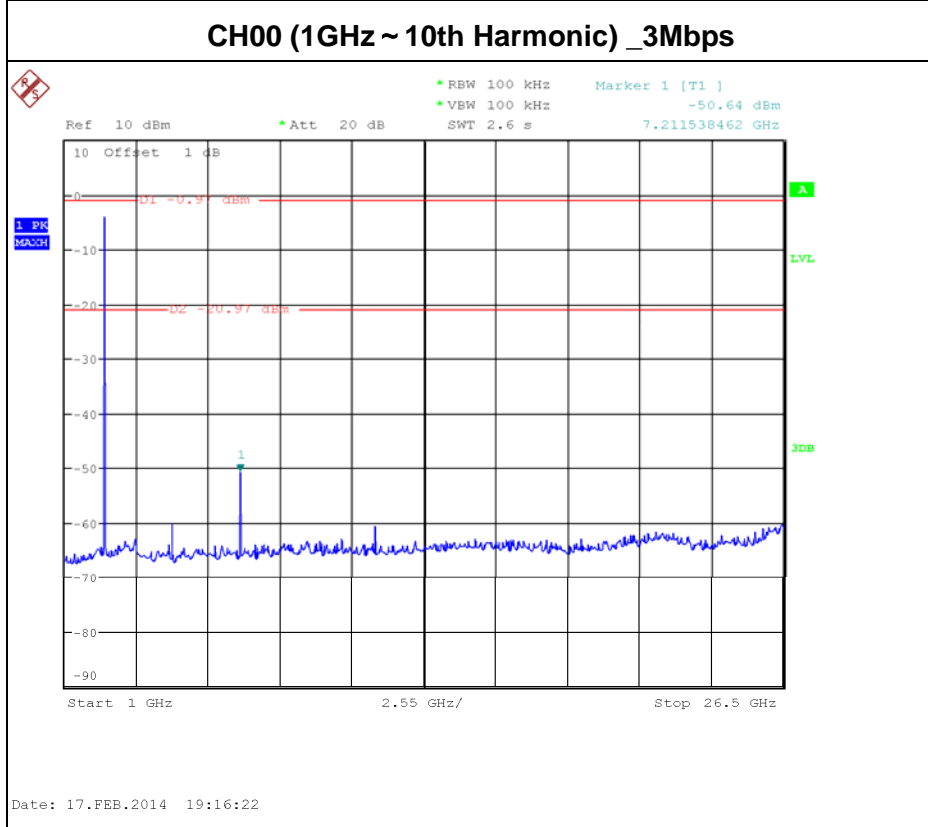
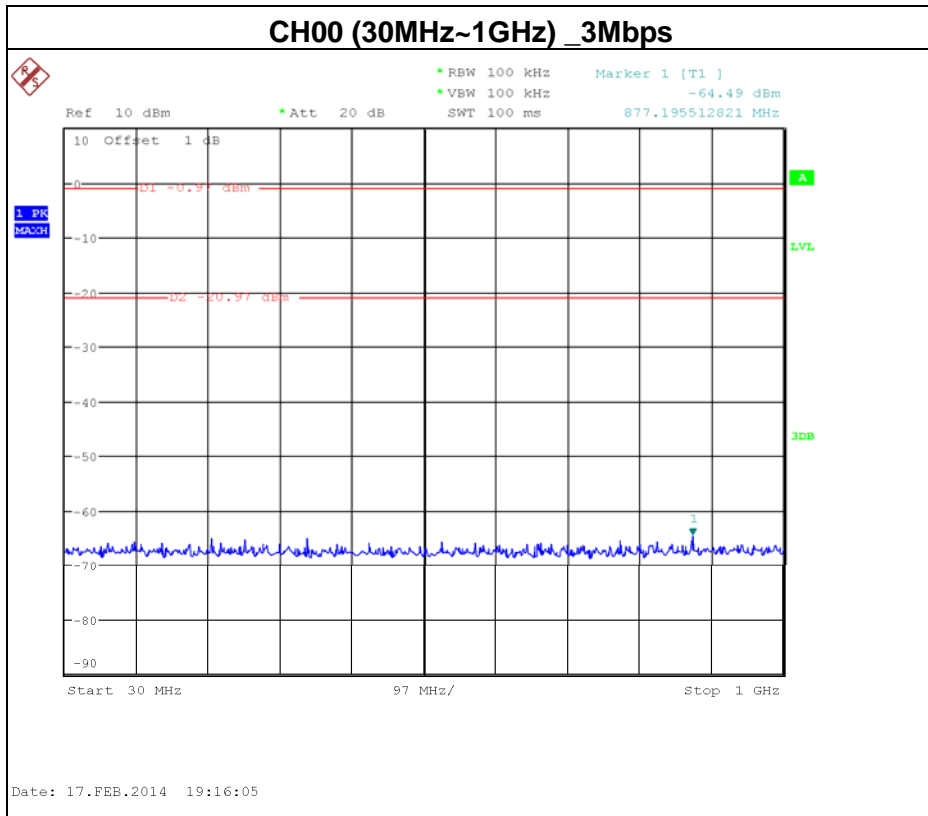

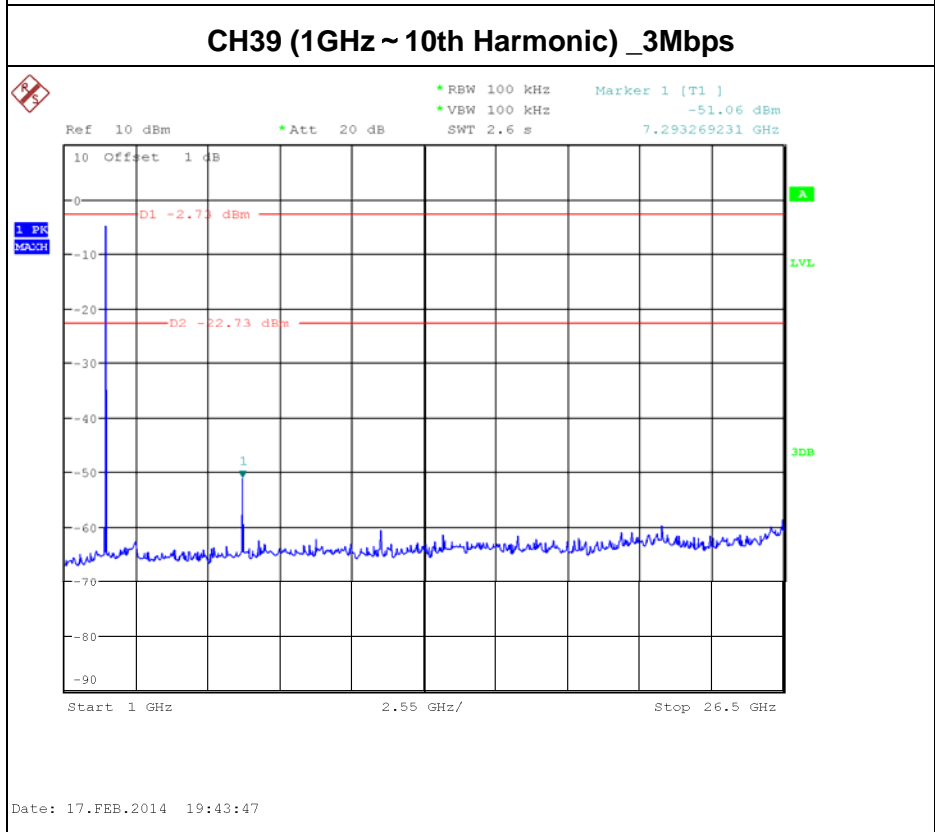
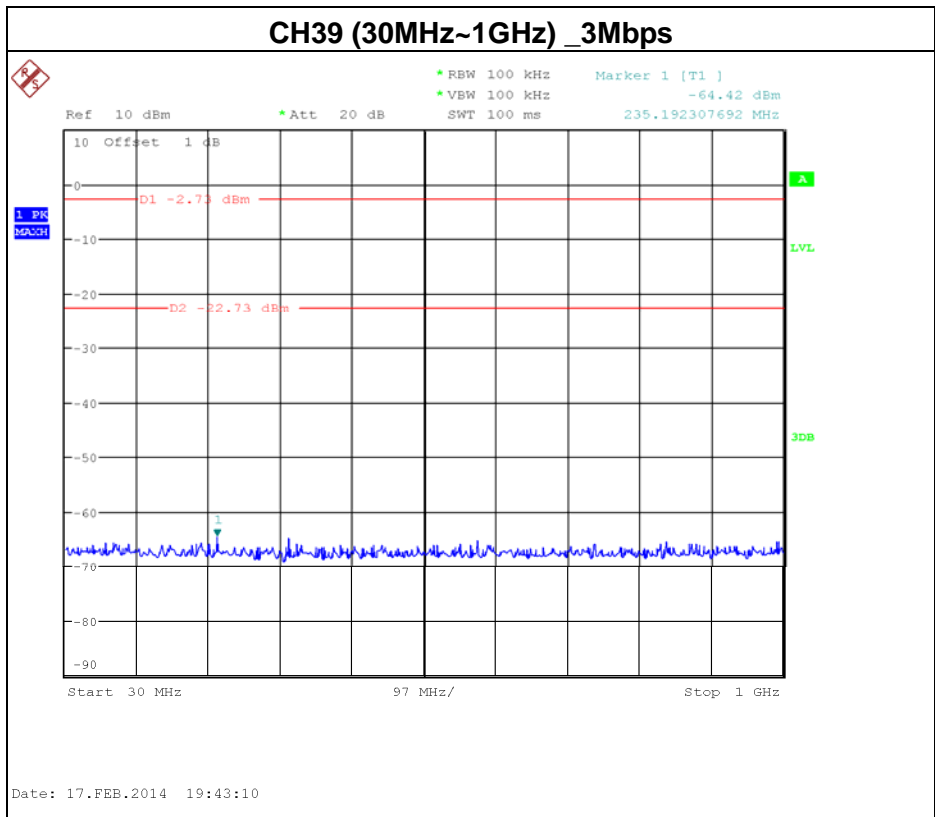

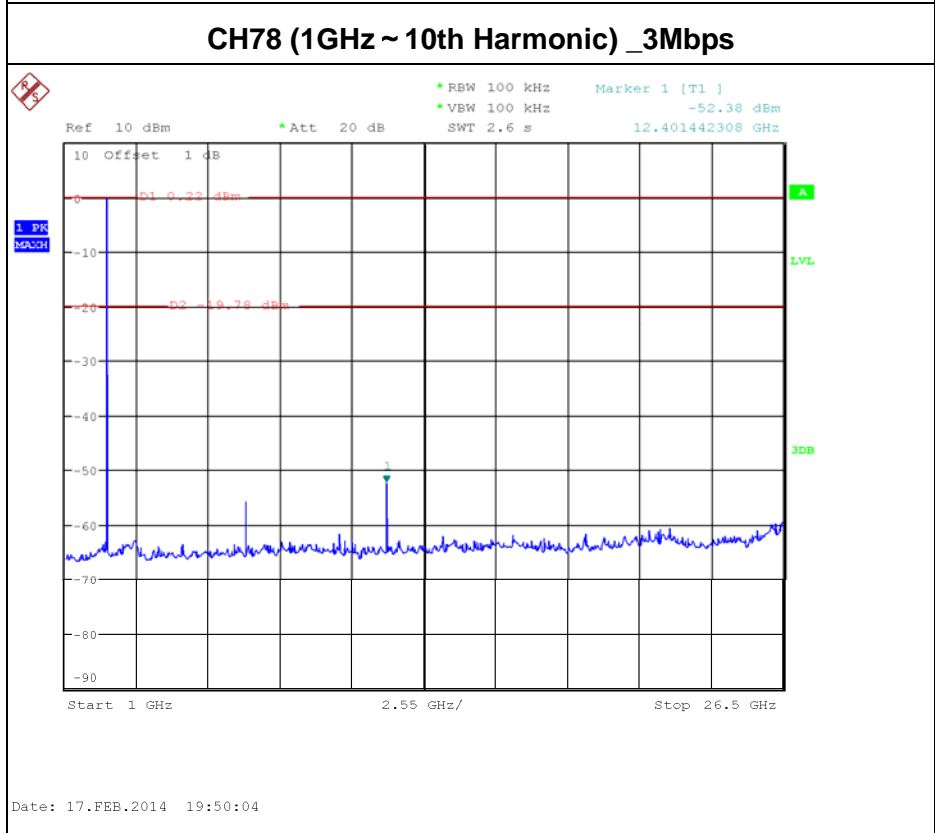
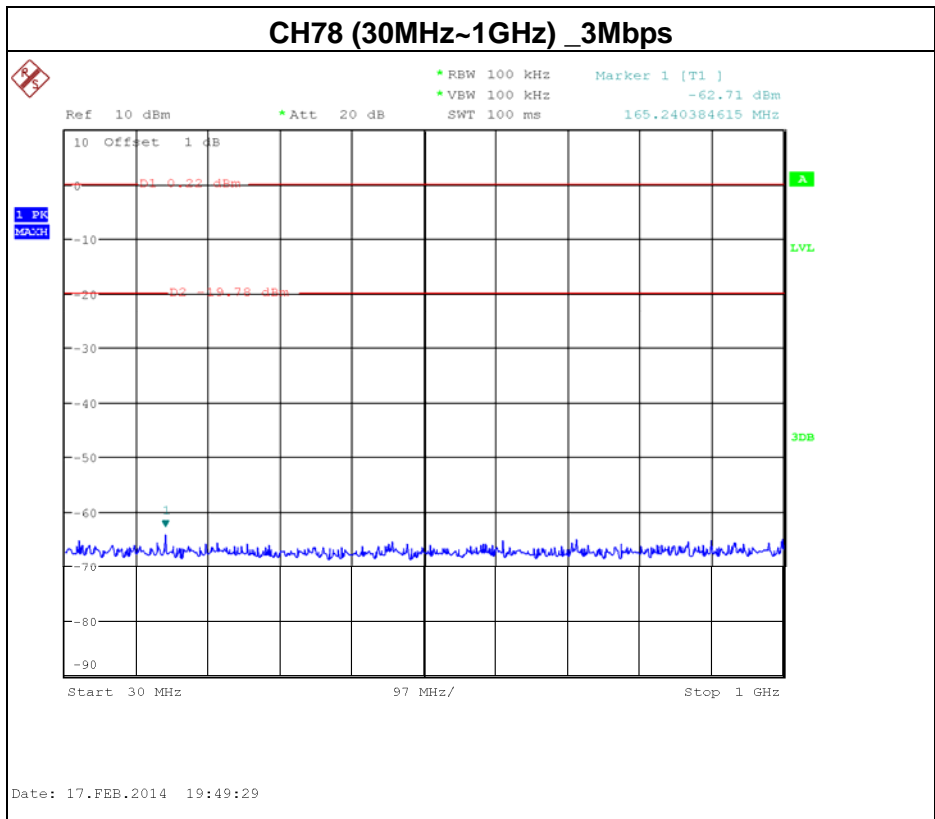



11. MEASUREMENT INSTRUMENTS LIST AND SETTING

Conducted Emission Measurement					
Item	Kind of Equipment	Manufacturer	Type No.	Serial No.	Calibrated until
1	LISN	EMCO	3816/2	00052765	Apr. 25, 2014
2	LISN	R&S	ENV216	100087	Nov. 11, 2014
3	Test Cable	N/A	C_17	N/A	Mar. 15, 2014
4	EMI TEST RECEIVER	R&S	ESCS30	833364/017	Nov. 11, 2014
5	50Ω Terminator	SHX	TF2-3G-A	08122902	Apr. 25, 2014

Radiated Emission Measurement					
Item	Kind of Equipment	Manufacturer	Type No.	Serial No.	Calibrated until
1	Antenna	Schwarbeck	VULB9160	9160-3232	Apr. 25, 2014
2	Amplifier	HP	8447D	2944A09673	Apr. 25, 2014
3	Test Receiver	R&S	ESCI	100382	Apr. 25, 2014
4	Test Cable	N/A	C-01_CB03	N/A	Jul. 02, 2014
5	Antenna	ETS	3115	00075789	Apr. 25, 2014
6	Amplifier	Agilent	8449B	3008A02274	Apr. 25, 2014
7	Spectrum	Agilent	E4408B	US39240143	Nov. 11, 2014
8	Test Cable	HUBER+SUHNER	C-45	N/A	Apr. 30, 2014
9	Controller	CT	SC100	N/A	N/A
10	Horn Antenna	EMCO	3115	9605-4803	Apr. 25, 2014
11	Active Loop Antenna	R&S	HFH2-Z2	830749/020	Apr. 25, 2014
12	Broad-Band Horn Antenna	Schwarzbeck	BBHA 9170	9170319	Oct. 22, 2014

Number of Hopping Channel					
Item	Kind of Equipment	Manufacturer	Type No.	Serial No.	Calibrated until
1	Spectrum Analyzer	R&S	FSP 40	100185	Nov. 11, 2014

Average Time of Occupancy					
Item	Kind of Equipment	Manufacturer	Type No.	Serial No.	Calibrated until
1	Spectrum Analyzer	R&S	FSP 40	100185	Nov. 11, 2014



Hopping Channel Separation Measurement

Item	Kind of Equipment	Manufacturer	Type No.	Serial No.	Calibrated until
1	Spectrum Analyzer	R&S	FSP 40	100185	Nov. 11, 2014

Bandwidth

Item	Kind of Equipment	Manufacturer	Type No.	Serial No.	Calibrated until
1	Spectrum Analyzer	R&S	FSP 40	100185	Nov. 11, 2014

Peak Output Power

Item	Kind of Equipment	Manufacturer	Type No.	Serial No.	Calibrated until
1	Spectrum Analyzer	R&S	FSP 40	100185	Nov. 11, 2014

Antenna Conducted Spurious Emission

Item	Kind of Equipment	Manufacturer	Type No.	Serial No.	Calibrated until
1	Spectrum Analyzer	R&S	FSP 40	100185	Nov. 11, 2014

Remark: "N/A" denotes no model name, serial no. or calibration specified.
 All calibration period of equipment list is one year.