





FCC PART 15, SUBPART C  
IC RSS-210, ISSUE 8, DECEMBER 2010  
TEST AND MEASUREMENT REPORT

For

**NVIDIA Corporation**

2701 San Tomas Expressway, Santa Clara, CA 95050, USA

**FCC ID: VOB-P1761WX**  
**IC: 7361A-P1761W**

<b>Report Type:</b> Original Report	<b>Product Type:</b> 802.11 a/b/g/n WLAN+BT combo radio Tablet
<b>Prepared By:</b> Rui Zhou	
<b>Report Number:</b> R1410015-247 Rev A	
<b>Report Date:</b> 2014-12-08	
<b>Reviewed By:</b> Bo Li RF Lead	
Bay Area Compliance Laboratories Corp. 1274 Anvilwood Avenue, Sunnyvale, CA 94089, USA Tel: (408) 732-9162 Fax: (408) 732-9164	

**Note:** This test report is prepared for the customer shown above and for the device described herein. It may not be duplicated or used in part without prior written consent from Bay Area Compliance Laboratories Corp. This report **must not** be used by the customer to claim product certification, approval, or endorsement by A2LA\*, NIST, or any agency of the Federal Government.

\* This report may contain data that are not covered by the A2LA accreditation and are marked with an asterisk "\*" ...

## TABLE OF CONTENTS

<b>1</b>	<b>General Description.....</b>	<b>5</b>
1.1	Product Description for Equipment Under Test (EUT) .....	5
1.2	Mechanical Description of EUT .....	5
1.3	Objective.....	5
1.4	Related Submittal(s)/Grant(s) .....	5
1.5	Test Methodology .....	5
1.6	Measurement Uncertainty .....	5
1.7	Test Facility .....	6
<b>2</b>	<b>System Test Configuration.....</b>	<b>7</b>
2.1	Justification .....	7
2.2	EUT Exercise Software.....	7
2.3	Special Equipment .....	7
2.4	Equipment Modifications.....	7
2.5	Local Support Equipment .....	7
2.6	EUT Internal Configuration Details.....	7
2.7	Power Supply and Line Filters.....	7
2.8	Interface Ports and Cabling.....	8
<b>3</b>	<b>Summary of Test Results .....</b>	<b>9</b>
<b>4</b>	<b>FCC §15.247 (i), §2.1093 &amp; IC RSS-102 – RF Exposure.....</b>	<b>10</b>
4.1	Applicable Standard.....	10
4.2	Test Result .....	10
<b>5</b>	<b>FCC §15.203 &amp; IC RSS-Gen §7.1.2 – Antenna Requirements .....</b>	<b>11</b>
5.1	Applicable Standard.....	11
5.2	Antenna Description .....	11
<b>6</b>	<b>FCC §15.207 &amp; IC RSS-Gen §7.2.4 – AC Line Conducted Emissions.....</b>	<b>12</b>
6.1	Applicable Standards .....	12
6.2	Test Setup .....	12
6.3	Test Procedure .....	12
6.4	Test Setup Block Diagram .....	13
6.5	Corrected Amplitude & Margin Calculation.....	13
6.6	Test Equipment List and Details.....	14
6.7	Test Environmental Conditions .....	14
6.8	Summary of Test Results.....	14
6.9	Conducted Emissions Test Plots and Data.....	15
<b>7</b>	<b>FCC §2.1051, §15.247(d) &amp; IC RSS-210 §A8.5 – Spurious Emissions at Antenna Terminals.....</b>	<b>17</b>
7.1	Applicable Standard.....	17
7.2	Measurement Procedure.....	17
7.3	Test Equipment List and Details.....	17
7.4	Test Environmental Conditions .....	17
7.5	Test Results.....	17
<b>8</b>	<b>FCC §15.205, §15.209 &amp; §15.247(d) &amp; IC RSS-210 A8.5 – Spurious Radiated Emissions .....</b>	<b>27</b>
8.1	Applicable Standard.....	27
8.2	Test Setup .....	28
8.3	Test Procedure .....	28
8.4	Corrected Amplitude & Margin Calculation.....	29
8.5	Test Equipment List and Details.....	29
8.6	Test Environmental Conditions .....	29
8.7	Summary of Test Results.....	30
8.8	Radiated Emissions Test Results .....	31
<b>9</b>	<b>FCC§15.247(a)(2) &amp; IC RSS-210 §A8.2 – 6 dB &amp; 99% Emission Bandwidth .....</b>	<b>40</b>

9.1 Applicable Standard..... 40

9.2 Measurement Procedure..... 40

9.3 Test Equipment List and Details..... 40

9.4 Test Environmental Conditions ..... 40

9.5 Test Results and Plots ..... 41

**10 FCC §15.247(b) & IC RSS-210 §A8.4 (4) – Output Power Measurement..... 50**

10.1 Applicable Standard..... 50

10.2 Measurement Procedure..... 50

10.3 Test Equipment List and Details..... 50

10.4 Test Environmental Conditions ..... 50

10.5 Test Results..... 51

**11 FCC §15.247(d) & IC RSS-210 §A8.5 – 100 kHz Bandwidth of Band Edges..... 53**

11.1 Applicable Standard..... 53

11.2 Measurement Procedure..... 53

11.3 Test Equipment List and Details..... 53

11.4 Test Environmental Conditions ..... 53

11.5 Test Results..... 53

**12 FCC §15.247(e) & IC RSS-210 §A8.2 (b) – Power Spectral Density ..... 58**

12.1 Applicable Standard..... 58

12.2 Measurement Procedure..... 58

12.3 Test Equipment List and Details..... 58

12.4 Test Environmental Conditions ..... 58

12.5 Test Results..... 59

**13 Exhibit A – FCC & IC Equipment Labeling Requirements ..... 68**

13.1 FCC ID Label Requirements ..... 68

13.2 IC Label Requirements ..... 68

13.3 FCC ID & IC Label Contents and Location..... 69

**14 Exhibit B – Test Setup Photographs ..... 70**

14.1 Radiated Emission below 1 GHz Front View at 3 Meters ..... 70

14.2 Radiated Emission below 1 GHz Rear View at 3 Meters ..... 70

14.3 Radiated Emission above 1 GHz Front View at 3 Meters ..... 71

14.4 Radiated Emission above 1 GHz Rear View at 3 Meters ..... 71

14.5 AC Line Conducted Emission Front View ..... 72

14.6 AC Line Conducted Emission Side View..... 72

**15 Exhibit C – EUT Photographs..... 73**

15.1 EUT – Front View ..... 73

15.2 EUT – Rear View ..... 73

15.3 EUT – Right Side View ..... 74

15.4 EUT – Left Side View ..... 74

15.5 EUT – Top View..... 75

15.6 EUT – Bottom View ..... 75

15.7 EUT – Open Case View..... 76

15.8 EUT – PCB Top View ..... 76

15.9 EUT – PCB Back View ..... 77

15.10 EUT – Battery View..... 77

15.11 EUT – AC/DC Adapter ..... 78

**DOCUMENT REVISION HISTORY**

<b>Revision Number</b>	<b>Report Number</b>	<b>Description of Revision</b>	<b>Date of Revision</b>
0	R1410015-247	Initial	2014-12-03
1	R1410015-247 Rev A	Updated power data	2014-12-08

## 1 General Description

---

### 1.1 Product Description for Equipment Under Test (EUT)

This test and measurement report was prepared on behalf of *NVIDIA Corporation* and their product FCC ID: VOB- P1761WX, IC: 7361A-P1761W or the “EUT” as referred to in this report. The EUT is a Tablet which operates in 2.4 GHz and 5 GHz bands.

### 1.2 Mechanical Description of EUT

The EUT measures approximately 218 mm (L) x 123 mm (W) x 8 mm (H) and weighs approximately 350 g.

*The test data gathered are from typical production sample, serial number: R1410015-1 assigned by BACL.*

### 1.3 Objective

This report is prepared on behalf of *NVIDIA Corporation* in accordance with Part 2, Subpart J, and Part 15, Subparts B and C of the Federal Communication Commissions rules.

The objective is to determine compliance with FCC Part 15.247 rules and IC RSS-210 rules for Output Power, Antenna Requirements, 6 dB Bandwidth, and power spectral density, 100 kHz Bandwidth of Band Edges Measurement, Spurious Emissions, Conducted and Radiated Spurious Emissions.

### 1.4 Related Submittal(s)/Grant(s)

FCC ID: VOB-P1761W

### 1.5 Test Methodology

All measurements contained in this report were conducted in accordance with ANSI C63.4-2009, American National Standard for Methods of Measurement of Radio-Noise Emissions from Low-Voltage Electrical and Electronic Equipment in the range of 9 kHz to 40 GHz and FCC KDB 558074 D01 DTS Meas Guidance v03r02: Guidance for Performing Compliance Measurements on Digital Transmission Systems (DTS) Operating Under §15.247

### 1.6 Measurement Uncertainty

All measurements involve certain levels of uncertainties, especially in the field of EMC. The factors contributing to uncertainties are spectrum analyzer, cable loss, antenna factor calibration, antenna directivity, antenna factor variation with height, antenna phase center variation, antenna factor frequency interpolation, measurement distance variation, site imperfections, mismatch (average), and system repeatability.

The following calculation follows the procedures as set forth in clause 7.2.3, ETSI TR 100 028-1 V1.4.1 (2001-12), the expression of Uncertainty in Radiated RF Testing is in accordance to ISO/IEC 17025 and TR 100 028-1 V1.4.1 (2001-12).

The expanded Measurement Uncertainty value having a confidence factor of 95%, is within a range of 5.48 dB. This means that the value of conducted RF carrier power test will be within +/- 2.74 dB of the measuring radiated emissions power versus the expected value.

The expected value is defined as the power at the antenna of the Transmitter under Test.

## 1.7 Test Facility

Bay area compliance Laboratories Corp. (BACL) is:

1- An independent Commercial Test Laboratory accredited to **ISO 17025: 2005** by **A2LA**, in the fields of: Electromagnetic Compatibility & Telecommunications covering Emissions, Immunity, Radio, RF Exposure, Safety and Telecom. This includes NEBS (Network Equipment Building System), Wireless RF, Telecommunications Terminal Equipment (TTE); Network Equipment; Information Technology Equipment (ITE); Medical Electrical Equipment; Industrial, Commercial, and Medical Test Equipment; Professional Audio and Video Equipment; Electronic (Digital) Products; Industrial and Scientific Instruments; Cabled Distribution Systems and Energy Efficiency Lighting.

2- An ENERGY STAR Recognized Laboratory, for the LM80 Testing, a wide variety of Luminaires and Computers.

3- A NIST Designated Phase-I and Phase-II CAB including: ACMA (Australian Communication and Media Authority), BSMI (Bureau of Standards, Metrology and Inspection of Taiwan), IDA (Infocomm Development Authority of Singapore), IC(Industry Canada), Korea ( Ministry of Communications Radio Research Laboratory), NCC (Formerly DGT; Directorate General of Telecommunication of Chinese Taipei) OFTA (Office of the Telecommunications Authority of Hong Kong), Vietnam, VCCI - Voluntary Control Council for Interference of Japan and a designated EU CAB (Conformity Assessment Body) (Notified Body) for the EMC and R&TTE Directives.

4- A Product Certification Body accredited to **ISO Guide 65: 1996** by **A2LA** to certify:

1- Unlicensed, Licensed radio frequency devices and Telephone Terminal Equipment for the FCC. Scope A1, A2, A3, A4, B1, B2, B3, B4 & C.

2. Radio Standards Specifications (RSS) in the Category I Equipment Standards List and All Broadcasting Technical Standards (BETS) in Category I Equipment Standards List for Industry Canada.

3. Radio Communication Equipment for Singapore.

4. Radio Equipment Specifications, GMDSS Marine Radio Equipment Specifications, and Fixed Network Equipment Specifications for Hong Kong.

5. Japan MIC Telecommunication Business Law (A1, A2) and Radio Law (B1, B2 and B3).

6. Audio/Video, Battery Charging Systems, Computers, Displays, Enterprise Servers, Imaging Equipment, Set-Top Boxes, Telephony, Televisions, Ceiling Fans, CFLs (Including GU24s), Decorative Light Strings, Integral LED Lamps, Luminaires, Residential Ventilating Fans.

The test site used by BACL Corp. to collect radiated and conducted emissions measurement data is located at its facility in Sunnyvale, California, USA.

The test site at BACL Corp. has been fully described in reports submitted to the Federal Communication Commission (FCC) and Voluntary Control Council for Interference (VCCI). The details of these reports have been found to be in compliance with the requirements of Section 2.948 of the FCC Rules on February 11 and December 10, 1997, and Article 8 of the VCCI regulations on December 25, 1997. The test site also complies with the test methods and procedures set forth in CISPR 22:2008 §10.4 for measurements below 1 GHz and §10.6 for measurements above 1 GHz as well as ANSI C63.4-2009, ANSI C63.4-2009, TIA/EIA-603 & CISPR 24:2010.

The Federal Communications Commission and Voluntary Control Council for Interference have the reports on file and they are listed under FCC registration number: 90464 and VCCI Registration No.: A-0027. The test site has been approved by the FCC and VCCI for public use and is listed in the FCC Public Access Link (PAL) database.

Additionally, BACL Corp. is an American Association for Laboratory Accreditation (A2LA) accredited laboratory (Lab Code 3297-02). The current scope of accreditations can be found at

<http://www.a2la.org/scopepdf/3297-02.pdf?CFID=1132286&CFTOKEN=e42a3240dac3f6ba-6DE17DCB-1851-9E57-477422F667031258&jsessionid=8430d44f1f47cf2996124343c704b367816b>

## 2 System Test Configuration

### 2.1 Justification

The EUT was configured for testing according to ANSI C63.4-2009 and FCC KDB 558074 D01 DTS Meas Guidance v03r02.

The EUT was tested in a testing mode to represent worst-case results during the final qualification test.

The worst-case data rates are determined to be as follows for each mode based upon investigation by measuring the average power, peak power and PPSD across all data rates bandwidths, and modulations.

### 2.2 EUT Exercise Software

N/A

### 2.3 Special Equipment

N/A

### 2.4 Equipment Modifications

No modifications were made to the EUT.

### 2.5 Local Support Equipment

Manufacturer	Description	Model No.	Serial No.
Lenovo	Laptop	G560-0679	CB08585694
DELL	Monitor	U2410f FP63	-
-	Headset	-	-

### 2.6 EUT Internal Configuration Details

Manufacturer	Description	Type	Serial Number
NVIDIA	Main PCB Board	P1761	-
Yuko	Battery	YOKU 3574152	AR14060940006167

### 2.7 Power Supply and Line Filters

Manufacturer	Description	Model	Part Number
NVIDIA Corporation	Power Adapter	Switching Power Adapter	SPA011AU5W2

## 2.8 Interface Ports and Cabling

Cable Description	Length (m)	To	From
RF Cable	<1.0	PSA	EUT
USB Cable	1.5	Laptop	EUT



### 3 Summary of Test Results

Results reported relate only to the product tested.

FCC & IC Rules	Description of Test	Results
FCC §15.247(i), §2.1093 IC RSS-102	RF Exposure	Compliant*
FCC §15.203 IC RSS-Gen §7.1.2	Antenna Requirement	Compliant
FCC §15.207(a) IC RSS-Gen §7.2.4	AC Line Conducted Emissions	Compliant
FCC §15.247 (d) IC RSS-210 §A8.5	Spurious Emissions at Antenna Port	Compliant
FCC §15.205 IC RSS-210 §2.2	Restricted Bands	Compliant
FCC §15.209, §15.247 (d) IC RSS-210 §A8.5	Radiated Spurious Emissions	Compliant
FCC §15.247(a)(2) IC RSS-210 §A8.2	6 dB Emission Bandwidth	Compliant
FCC §15.247(b)(3) IC RSS-210 §A8.4	Maximum Peak Output Power	Compliant
FCC §15.247(d) IC RSS-210 §A8.5	100 kHz Bandwidth of Frequency Band Edge	Compliant
FCC §15.247(e) IC RSS-210 §A8.2(b)	Power Spectral Density	Compliant

Note: please refer to R1410015-SAR.

## **4 FCC §15.247 (i), §2.1093 & IC RSS-102 – RF Exposure**

---

### **4.1 Applicable Standard**

FCC §2.1093, §15.247(i) and IC RSS-102

### **4.2 Test Result**

Compliance, please refer to the SAR report: R1410015-SAR.

## 5 FCC §15.203 & IC RSS-Gen §7.1.2 – Antenna Requirements

### 5.1 Applicable Standard

According to FCC §15.203, an intentional radiator shall be designed to ensure that no antenna other than that furnished by the responsible party shall be used with the device. The use of a permanently attached antenna or of an antenna that uses a unique coupling to the intentional radiator shall be considered sufficient to comply with the provisions of this Section. The manufacturer may design the unit so that a broken antenna can be replaced by the user, but the use of a standard antenna jack or electrical connector is prohibited.

According to IC RSS-Gen §7.1.2: Transmitter Antenna

A transmitter can only be sold or operated with antennas with which it was certified. A transmitter may be certified with multiple antenna types. An antenna type comprises antennas having similar in-band and out-of-band radiation patterns. Testing shall be performed using the highest-gain antenna of each combination of transmitter and antenna type for which certification is being sought, with the transmitter output power set at the maximum level. Any antenna of the same type and having equal or lesser gain as an antenna that had been successfully tested for certification with the transmitter, will also be considered certified with the transmitter, and may be used and marketed with the transmitter. The manufacturer shall include with the application for certification a list of acceptable antenna types to be used with the transmitter.

When a measurement at the antenna connector is used to determine RF output power, the effective gain of the device's antenna shall be stated, based on measurement or on data from the antenna manufacturer. Any antenna gain in excess of 6 dBi (6 dB above isotropic gain) shall be added to the measured RF output power before using the power limits specified in RSS-210 or RSS-310 for devices of RF output powers of 10 mW or less. For devices of output powers greater than 10 mW, except devices subject to RSS-210 Annex 8 (Frequency Hopping and Digital Modulation Systems Operating in the 902-928 MHz, 2400-2483.5 MHz, and 5725-5850 MHz Bands) or RSS-210 Annex 9 (Local Area Network Devices), the total antenna gain shall be added to the measured RF output power before using the specified power limits. For devices subject to RSS-210 Annex 8 or Annex 9, the antenna gain shall not be added.

Note: The power setting was controlled by manufacture with different antenna configuration. The power setting of the different antenna will be set with the corresponded value and no more than the level reported.

### 5.2 Antenna Description

Antenna Location	Antenna Gain (dBi) @ 2.4 GHz
Wi-Fi 0	1.8
Wi-Fi 1	3.0

The antenna consists of non-standard (UFL) connectors; it complies with the antenna requirement. Please refer to the internal photos.

## 6 FCC §15.207 & IC RSS-Gen §7.2.4 – AC Line Conducted Emissions

### 6.1 Applicable Standards

As per FCC §15.207 Conducted limits:

For an intentional radiator that is designed to be connected to the public utility (AC) power line, the radio frequency voltage that is conducted back onto the AC power line on any frequency or frequencies within the band 150 kHz to 30 MHz shall not exceed the limits in the following table, as measured using a 50  $\mu$ H/50 ohms line impedance stabilization network (LISN). Compliance with the provisions of this paragraph shall be based on the measurement of the radio frequency voltage between each power line and ground at the power terminal. The lower limit applies at the boundary between the frequencies ranges.

As per IC RSS-Gen §7.2.4 Conducted limits:

Except when the requirements applicable to a given device state otherwise, for any radio apparatus equipped to operate from the public utility AC power supply, either directly or indirectly (such as with a battery charger), the radio frequency voltage of emissions conducted back onto the AC power lines in the frequency range of 0.15 MHz to 30 MHz shall not exceed the limits shown in the table below. The more stringent limit applies at the frequency range boundaries. The conducted emissions shall be measured with a 50 ohm/50 microhenry line impedance stabilization network (LISN).

Frequency of Emission (MHz)	Conducted Limit (dBuV)	
	Quasi-Peak	Average
0.15-0.5	66 to 56 *	56 to 46 *
0.5-5	56	46
5-30	60	50

*\*Decreases with the logarithm of the frequency.*

### 6.2 Test Setup

The measurement was performed at shield room, using the setup per ANSI C63.4-2009 measurement procedure. The specification used was FCC §15.207 limits.

External I/O cables were draped along the edge of the test table and bundle when necessary.

The POE power adapter of the EUT was connected with LISN which provided 120 V / 60 Hz AC power.

### 6.3 Test Procedure

Maximizing procedure was performed on the highest emissions of the EUT.

All data was recorded in the peak detection mode, quasi-peak and average. Quasi-Peak readings are distinguished with a “QP.” Average readings are distinguished with an “Ave”.

### 6.4 Test Setup Block Diagram

**AC/DC Adaptor:**

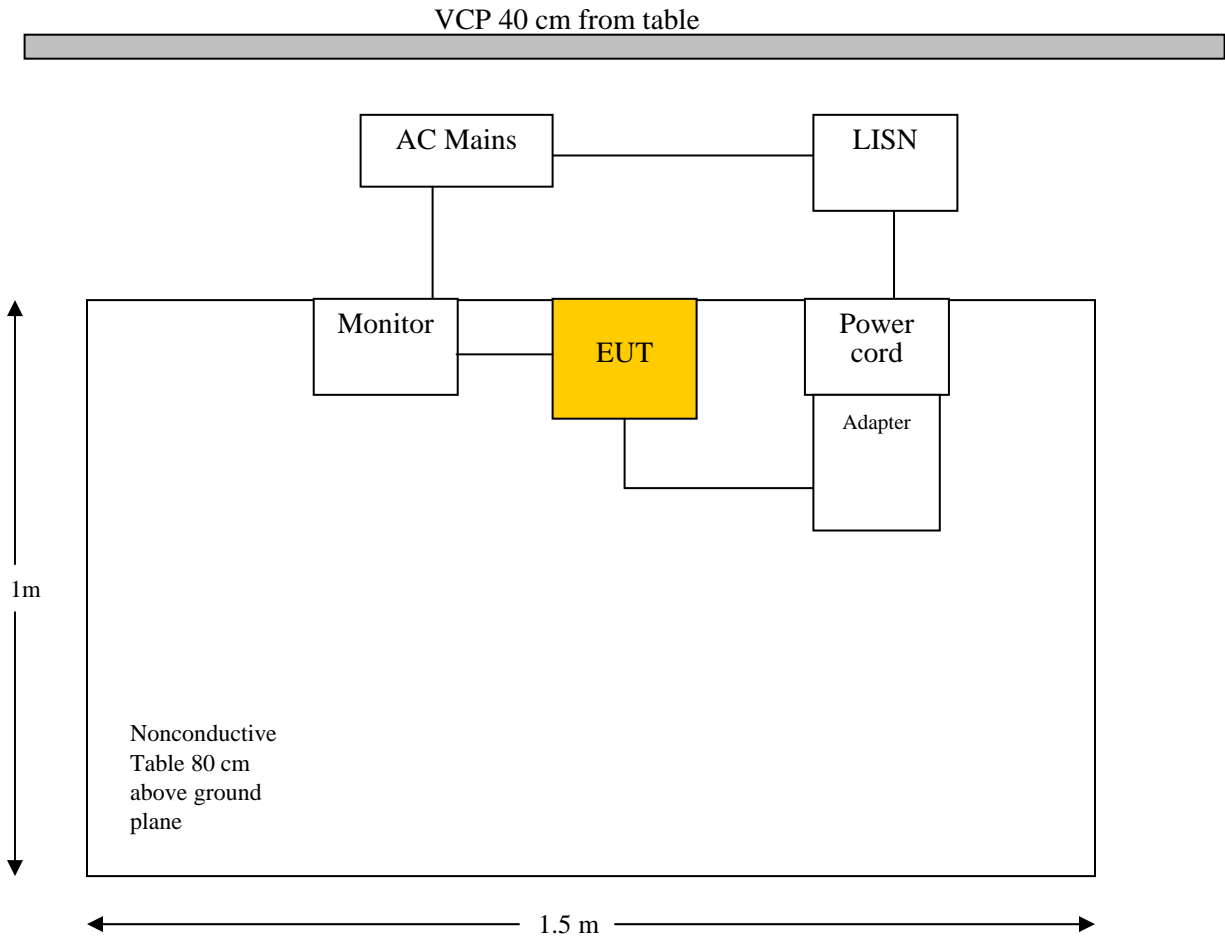

### 6.5 Corrected Amplitude & Margin Calculation

The Corrected Amplitude (CA) is calculated by adding the Cable Loss (CL), the Attenuator Factor (Atten) to indicated Amplitude (Ai) reading. The basic equation is as follows:

$$CA = Ai + CL + Atten$$

For example, a corrected amplitude of 46.2 dBuV = Indicated Reading (32.5 dBuV) + Cable Loss (3.7 dB) + Attenuator (10 dB)

The “**Margin**” column of the following data tables indicates the degree of compliance within the applicable limit. For example, a margin of -7 dB means the emission is 7 dB below the maximum limit. The equation for margin calculation is as follows:

$$\text{Margin} = \text{Corrected Amplitude} - \text{Limit}$$

## 6.6 Test Equipment List and Details

Manufacturer	Description	Model No.	Serial No.	Calibration Date	Calibration Interval
Rohde & Schwarz	EMI Test Receiver	ESCI 1166.5950K03	100337	2014-03-28	1 year
Solar Electronics	LISN	9252-50-R-24-N	511213	2014-07-14	1 year
TTE	Filter, High Pass	H962-150K-50-21378	K7133	2013-07-30	1 year

**Statement of Traceability:** *BACL Corp.* attests that all calibrations have been performed per the A2LA requirements, traceable to the NIST.

## 6.7 Test Environmental Conditions

<b>Temperature:</b>	22-24 °C
<b>Relative Humidity:</b>	40-41 %
<b>ATM Pressure:</b>	103.1-104.1 kPa

The testing was performed by Cipher Chu on 2014-05-14 to 2014-05-23 in 5m chamber3.

## 6.8 Summary of Test Results

According to the recorded data in following table, the EUT complied with the FCC 15C and IC RSS-210 standard's conducted emissions limits, with the margin reading of:

Note: AC line conducted test data please refer to R1405121-247 by Bay Area Compliance Lab.

Connection: AC/DC adapter connected to 120 V/60 Hz, AC			
Margin (dB)	Frequency (MHz)	Conductor Mode (Line/Neutral)	Range (MHz)
-12.09	1.378296	Neutral	0.15-30







## 7 FCC §2.1051, §15.247(d) & IC RSS-210 §A8.5 – Spurious Emissions at Antenna Terminals

### 7.1 Applicable Standard

For FCC §15.247(d) and IC RSS-210 §A8.5 in any 100 kHz bandwidth outside the frequency band in which the spread spectrum or digitally modulated intentional radiator is operating, the radio frequency power that is produced by the intentional radiator shall be at least 30 dB below that in the 100 kHz bandwidth within the band that contains the highest level of the desired power, based on either an RF conducted or a radiated measurement, provided the transmitter demonstrates compliance with the peak conducted power limits.

### 7.2 Measurement Procedure

The measurements are based on FCC KDB 558074 D01 DTS Meas Guidance v03r02: Guidance for Performing Compliance Measurements on Digital Transmission Systems (DTS) Operating Under §15.247 section 11: Emissions in non-restricted frequency bands and section 12: Emissions in restricted frequency bands.

### 7.3 Test Equipment List and Details

Manufacturer	Description	Model No.	Serial No.	Calibration Date	Calibration Interval
Agilent	Spectrum Analyzer	E4440A	MY44303352	2013-10-16	1 year

*Statement of Traceability: BACL Corp. attests that all calibrations have been performed per the A2LA requirements, traceable to the NIST.*

### 7.4 Test Environmental Conditions

<b>Temperature:</b>	22-24 °C
<b>Relative Humidity:</b>	42-45 %
<b>ATM Pressure:</b>	101-102 kPa

*The testing was performed by Rui Zhou from 2014-10-06 and 2014-10-07 at RF site.*

### 7.5 Test Results

Please refer to following plots of spurious emissions.

802.11b, Low Channel, 2412 MHz

WIFI 0:30MHz- 26GHz

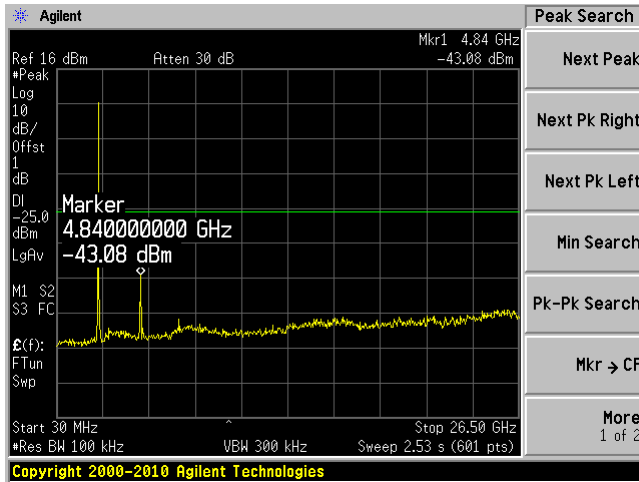

WIFI 1: 30MHz – 3GHz

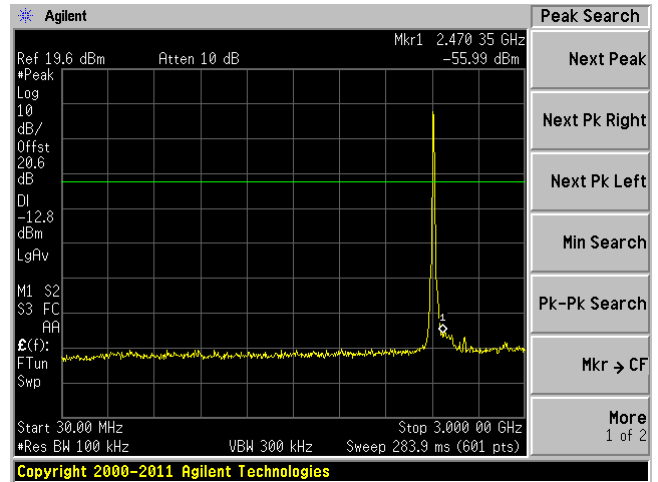

WIFI 1: 3GHz – 26 GHz

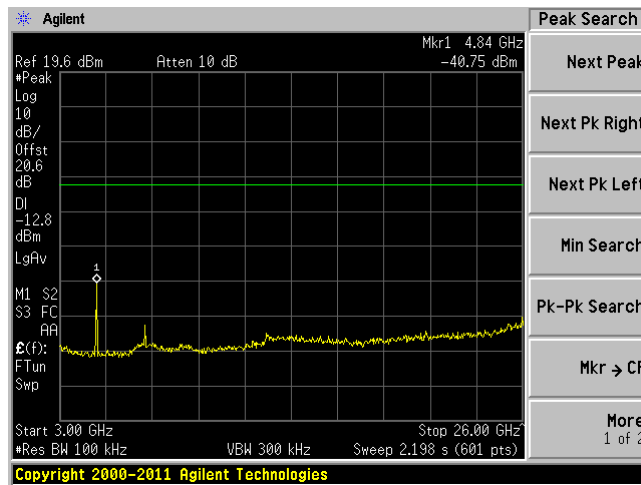

802.11b, Middle Channel, 2437 MHz

WIFI 0:30MHz- 26GHz

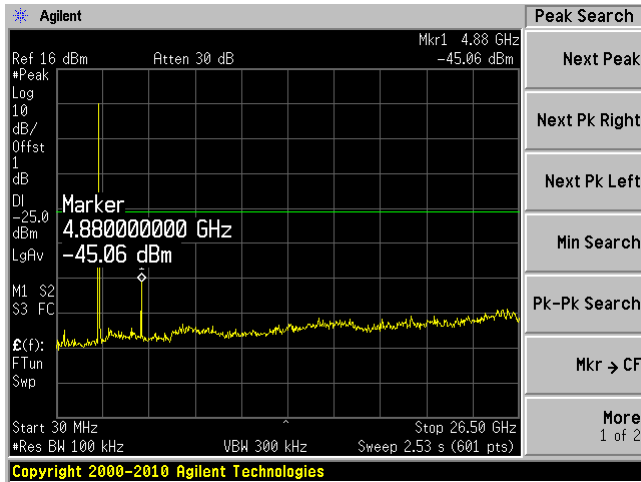

WIFI 1: 30MHz – 3GHz

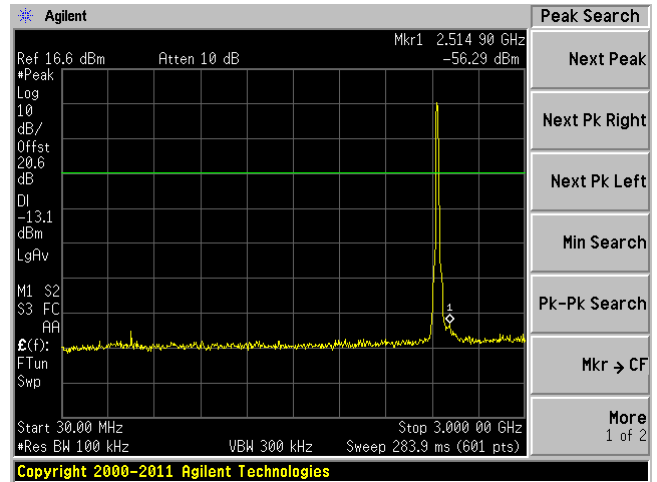

WIFI 1: 3GHz – 26 GHz

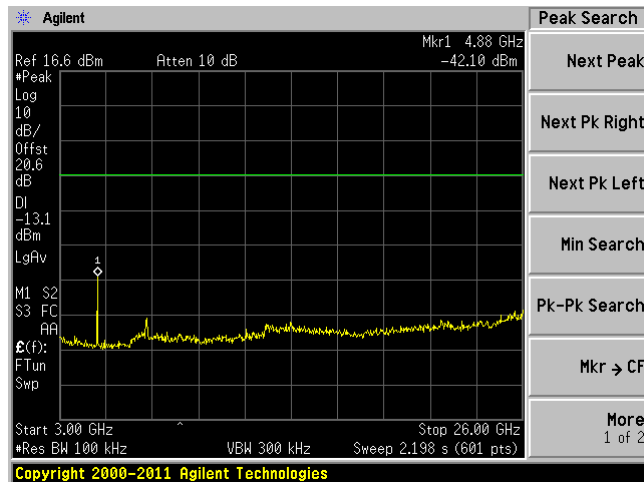

### 802.11b, High Channel, 2462 MHz

WIFI 0:30MHz- 26GHz

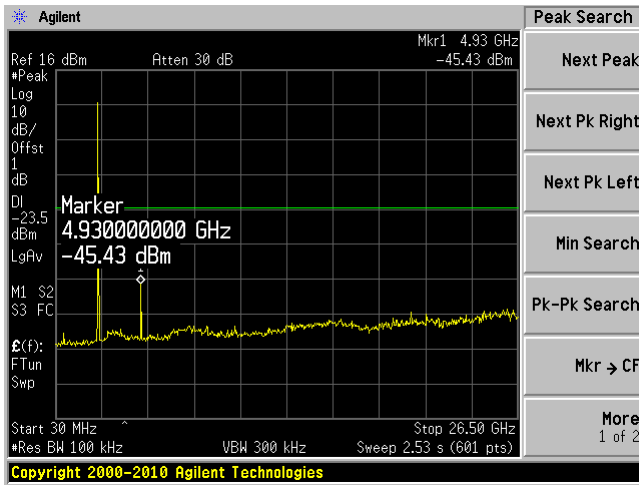

WIFI 1: 30MHz - 3GHz

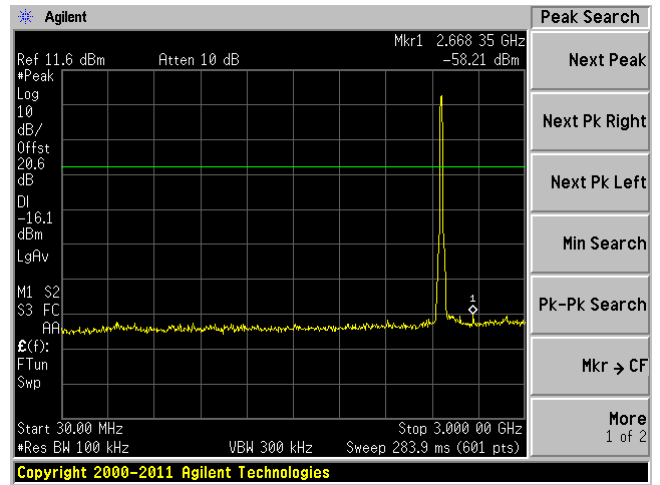

WIFI 1: 3GHz - 26 GHz

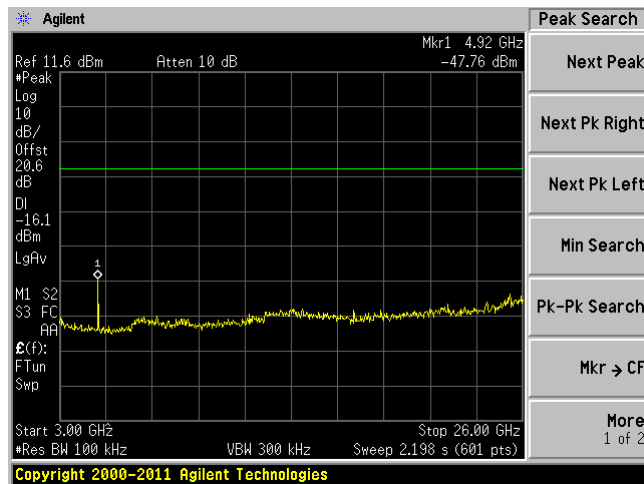

802.11g, Low Channel 2412 MHz

WIFI 0:30MHz- 26GHz

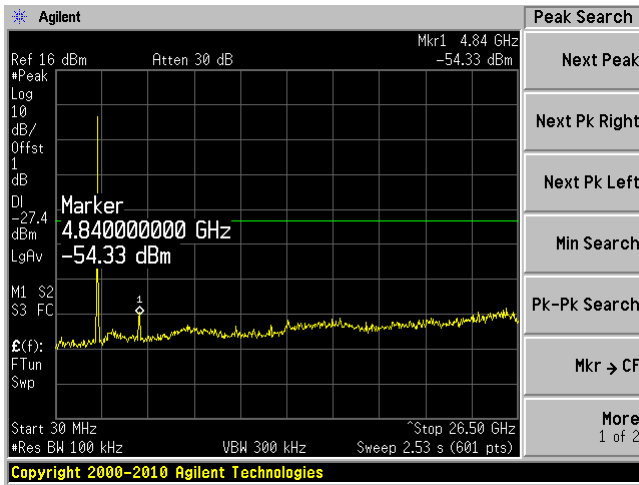

WIFI 1: 30MHz – 3GHz

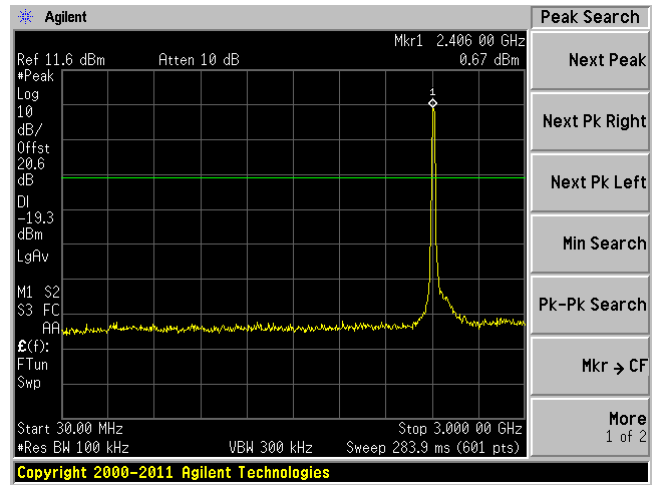

WIFI 1: 3GHz – 26 GHz

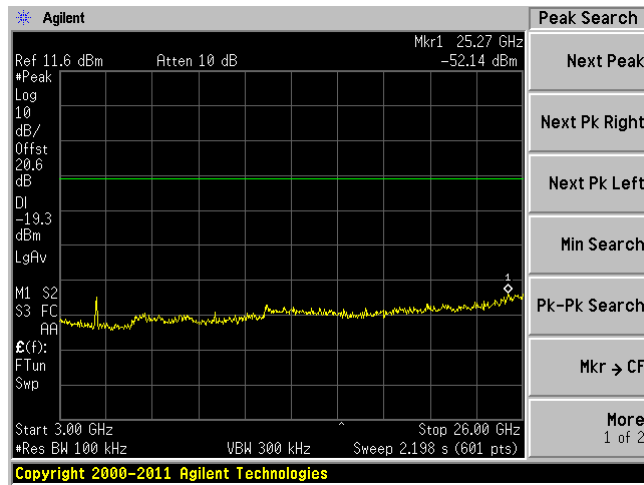

### 802.11g, Middle Channel 2437 MHz

WIFI 0:30MHz- 26GHz

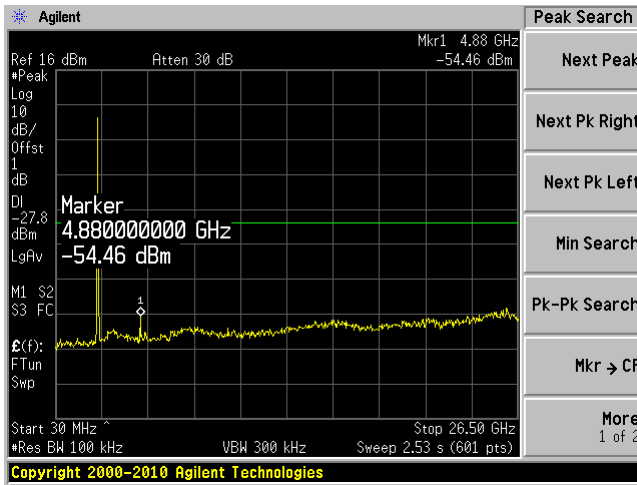

WIFI 1: 30MHz – 3GHz

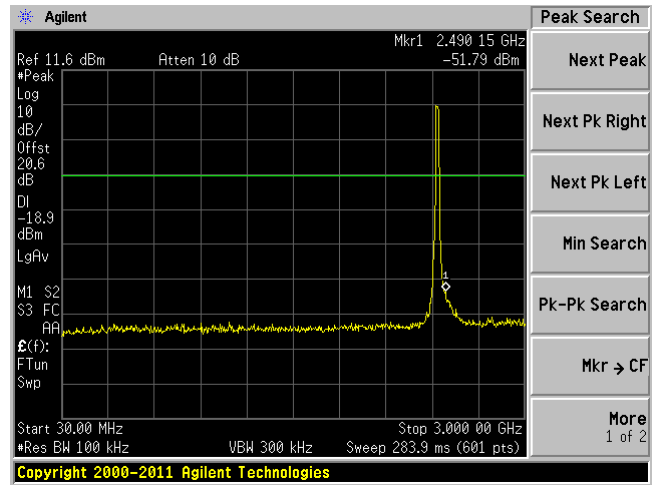

WIFI 1: 3GHz – 26 GHz

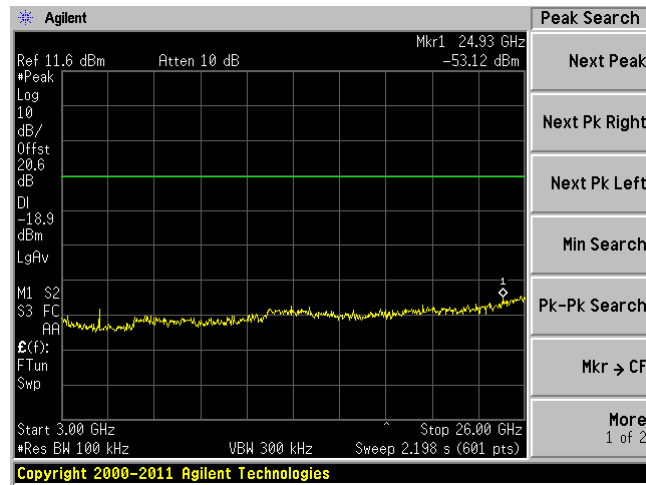

802.11g, High Channel 2462 MHz

WIFI 0:30MHz- 26GHz

WIFI 1: 30MHz – 3GHz

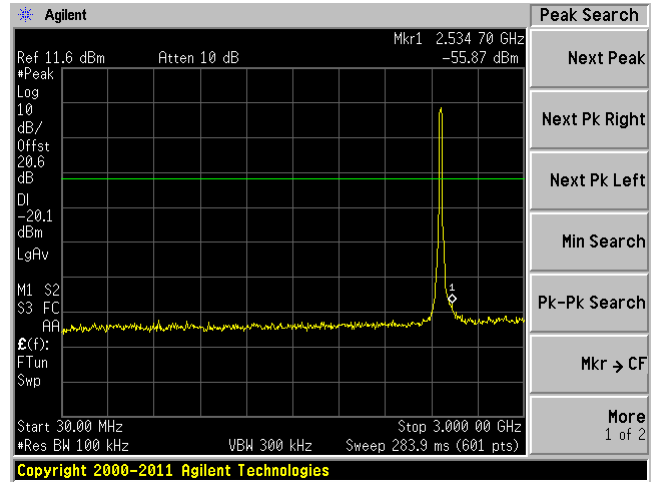
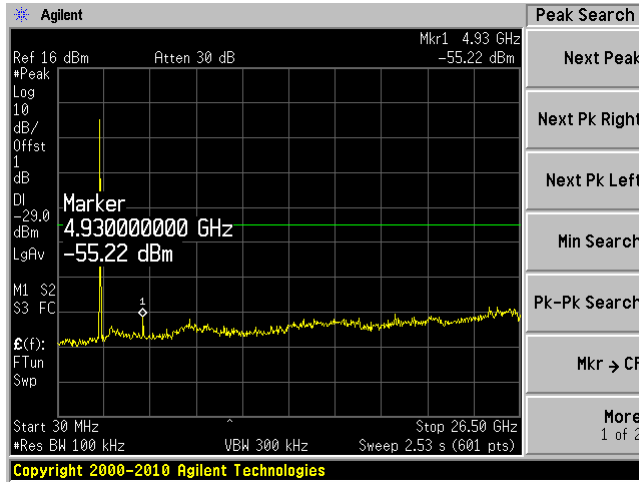

WIFI 1: 3GHz – 26 GHz

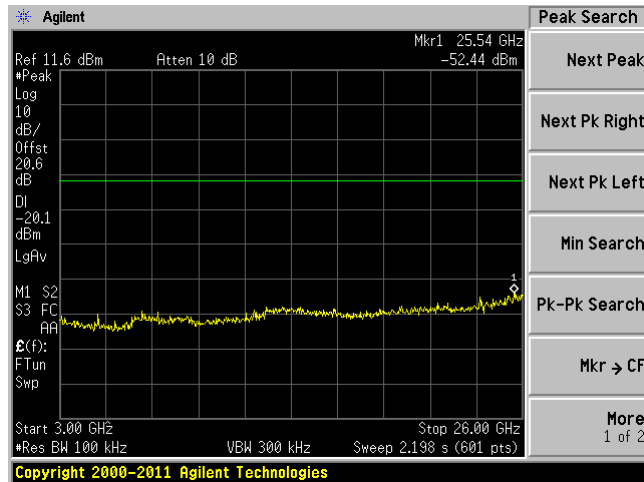

### 802.11n-HT20, Low Channel 2412 MHz

WIFI 0:30MHz- 26GHz

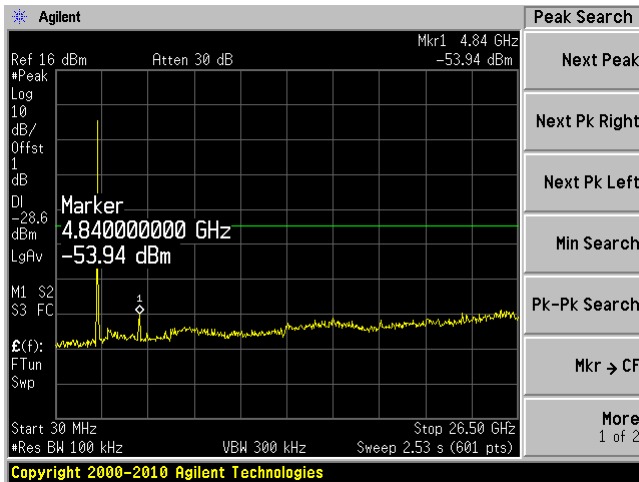

WIFI 1: 30MHz – 3GHz

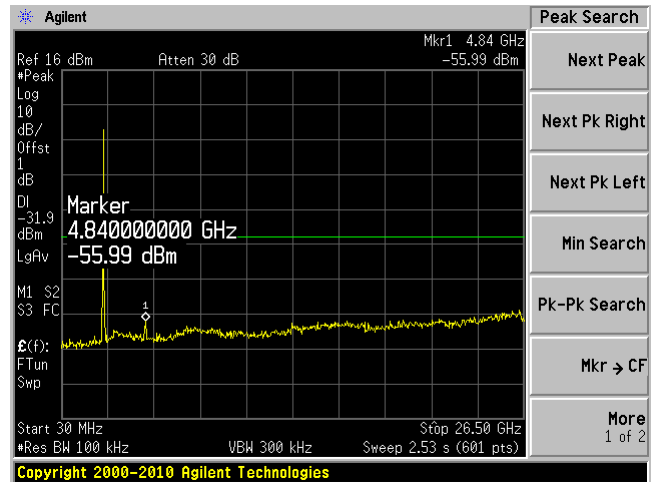

### 802.11n-HT20, Middle Channel 2437 MHz

WIFI 0:30MHz- 26GHz

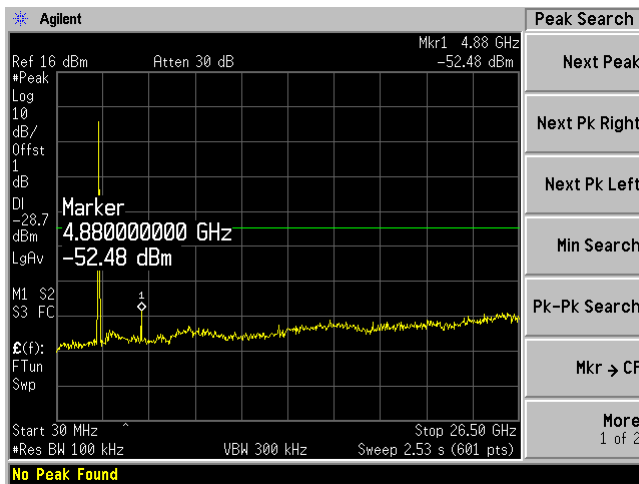

WIFI 1: 30MHz – 26GHz

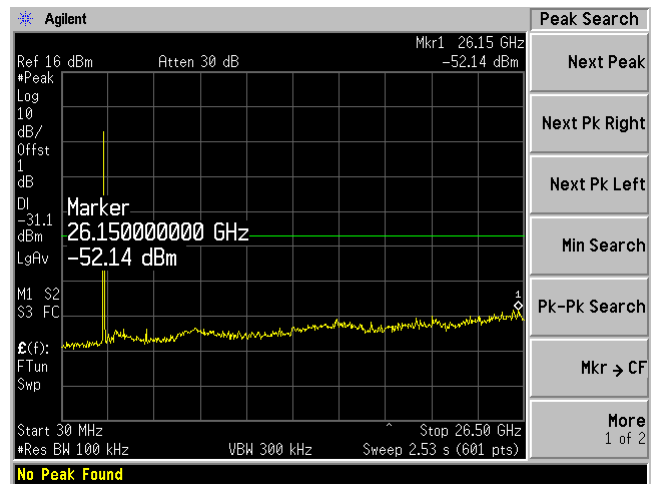



### 802.11n-HT20, High Channel 2462 MHz

WIFI 0:30MHz- 26GHz

WIFI 1: 30MHz – 26GHz

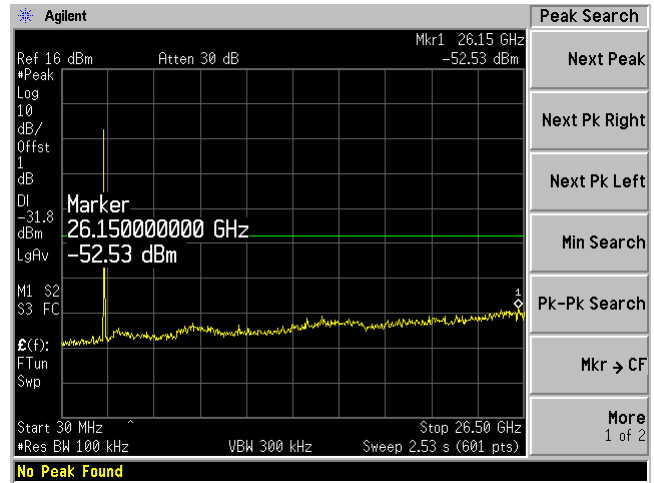
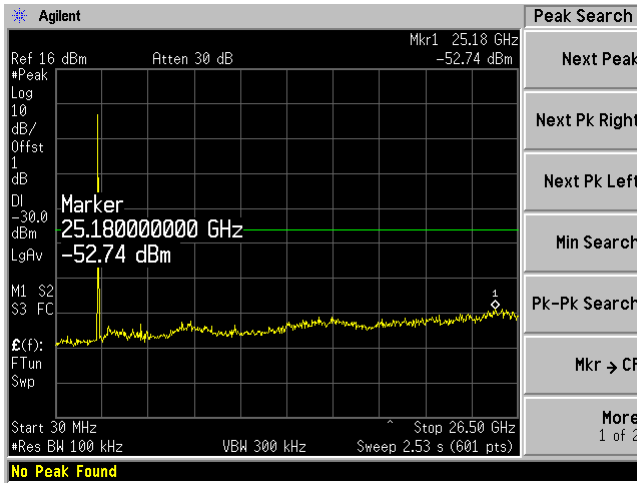

### 802.11n-HT40, Low Channel 2422 MHz

WIFI 0:30MHz- 26GHz

WIFI 1: 30MHz – 26GHz

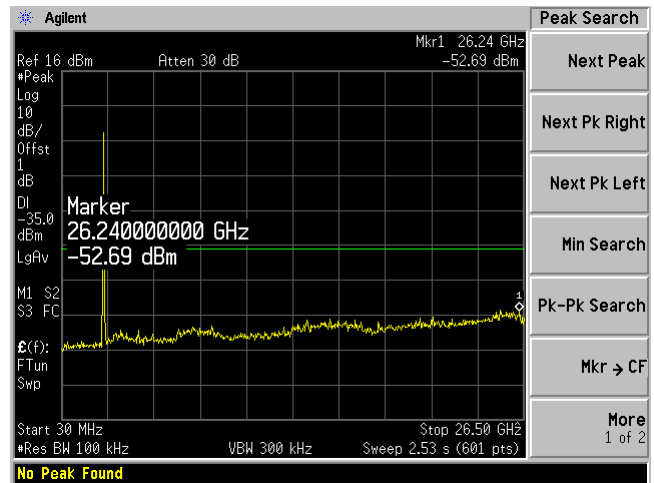
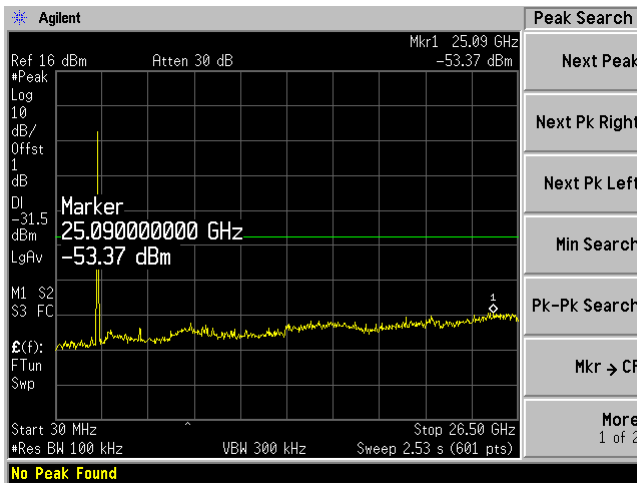

### 802.11n-HT40, Middle Channel 2437 MHz

WIFI 0:30MHz- 26GHz

WIFI 1: 30MHz – 26GHz

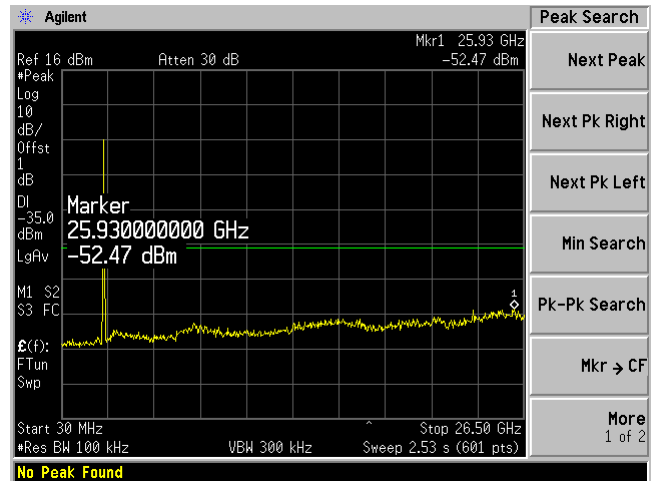
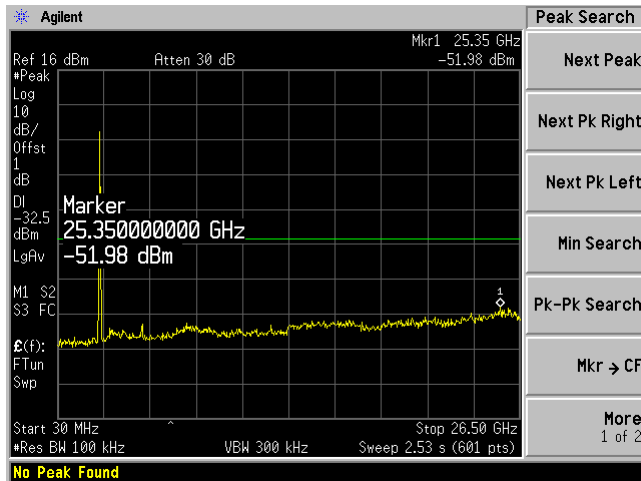

### 802.11n-HT40, High Channel 2452 MHz

WIFI 0:30MHz- 26GHz

WIFI 1: 30MHz – 26GHz

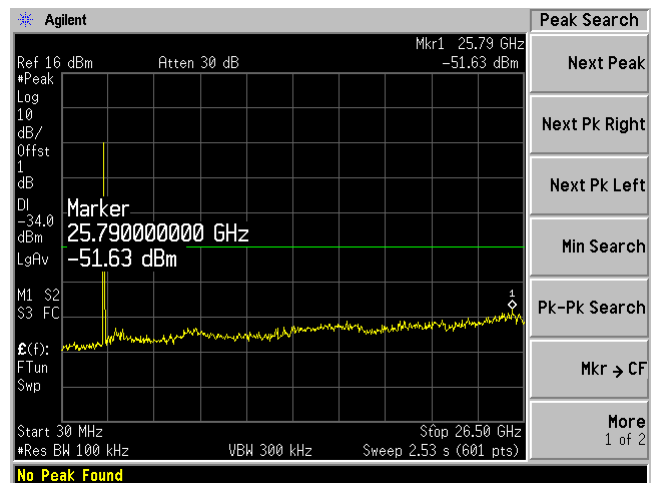
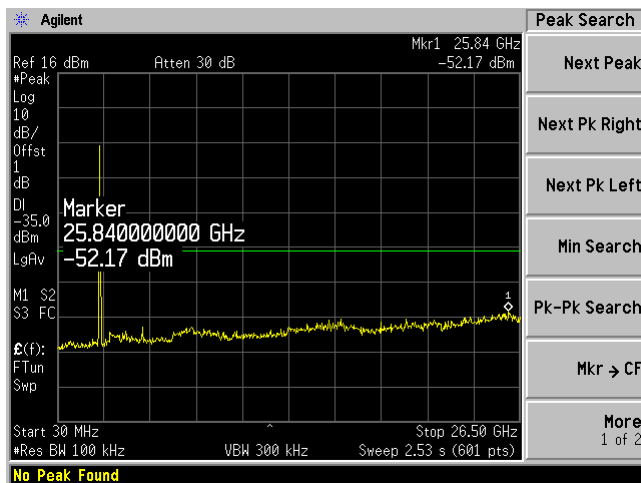

## 8 FCC §15.205, §15.209 & §15.247(d) & IC RSS-210 A8.5 – Spurious Radiated Emissions

### 8.1 Applicable Standard

As per FCC §15.35(d): Unless otherwise specified, on any frequency or frequencies above 1000 MHz, the radiated emission limits are based on the use of measurement instrumentation employing an average detector function. Unless otherwise specified, measurements above 1000 MHz shall be performed using a minimum resolution bandwidth of 1 MHz.

As per FCC §15.209(a) and RSS-210: Except as provided elsewhere in this Subpart, the emissions from an intentional radiator shall not exceed the field strength levels specified in the following table

Frequency (MHz)	Field Strength (micro volts/meter)	Measurement Distance (meters)
0.009 - 0.490	2400/F(kHz)	300
0.490 - 1.705	24000/F(kHz)	30
1.705 - 30.0	30	30
30 - 88	100**	3
88 - 216	150**	3
216 - 960	200**	3
Above 960	500	3

\*\* Except as provided in paragraph (g), fundamental emissions from intentional radiators operating under this Section shall not be located in the frequency bands 54-72 MHz, 76-88 MHz, 174-216 MHz or 470-806 MHz. However, operation within these frequency bands is permitted under other sections of this Part, e.g., Sections 15.231 and 15.241.

As Per FCC §15.205(a) except as show in paragraph (d) of this section, only spurious emissions are permitted in any of the frequency bands listed below:

MHz	MHz	MHz	GHz
0.090 – 0.110	16.42 – 16.423	960 – 1240	4.5 – 5.15
0.495 – 0.505	16.69475 – 16.69525	1300 – 1427	5.35 – 5.46
2.1735 – 2.1905	25.5 – 25.67	1435 – 1626.5	7.25 – 7.75
4.125 – 4.128	37.5 – 38.25	1645.5 – 1646.5	8.025 – 8.5
4.17725 – 4.17775	73 – 74.6	1660 – 1710	9.0 – 9.2
4.20725 – 4.20775	74.8 – 75.2	1718.8 – 1722.2	9.3 – 9.5
6.215 – 6.218	108 – 121.94	2200 – 2300	10.6 – 12.7
6.26775 – 6.26825	123 – 138	2310 – 2390	13.25 – 13.4
6.31175 – 6.31225	149.9 – 150.05	2483.5 – 2500	14.47 – 14.5
8.291 – 8.294	156.52475 – 156.52525	2690 – 2900	15.35 – 16.2
8.362 – 8.366	156.7 – 156.9	3260 – 3267	17.7 – 21.4
8.37625 – 8.38675	162.0125 – 167.17	3.332 – 3.339	22.01 – 23.12
8.41425 – 8.41475	167.72 – 173.2	3 3458 – 3 358	23.6 – 24.0
12.29 – 12.293	240 – 285	3.600 – 4.400	31.2 – 31.8
12.51975 – 12.52025	322 – 335.4		36.43 – 36.5
12.57675 – 12.57725	399.9 – 410		Above 38.6
13.36 – 13.41	608 – 614		

As per FCC §15.247 (d) In any 100 kHz bandwidth outside the frequency band in which the spread spectrum or digitally modulated intentional radiator is operating, the radio frequency power that is produced by the intentional radiator shall be at least 20 dB below that in the 100 kHz bandwidth within the band that contains the highest level of the desired power, based on either an RF conducted or a radiated measurement, provided the transmitter demonstrates compliance with the peak conducted power limits. If the transmitter complies with the conducted power limits based on the use of RMS averaging over a time interval, as permitted under paragraph (b)(3) of this section, the attenuation required under this paragraph shall be 30 dB instead of 20 dB. Attenuation below the general limits specified in §15.209(a) is not required. In addition, radiated emissions which fall in the restricted bands, as defined in §15.205(a), must also comply with the radiated emission limits specified in §15.209(a) (see §15.205(c)).

As per IC RSS-210 A8.5 Out-of-band Emissions, In any 100 kHz bandwidth outside the frequency band in which the spread spectrum or digitally modulated device is operating, the RF power that is produced shall be at least 20 dB below that in the 100 kHz bandwidth within the band that contains the highest level of the desired power, based on either an RF conducted or a radiated measurement, provided that the transmitter demonstrates compliance with the peak conducted power limits. If the transmitter complies with the conducted power limits based on the use of root-mean-square averaging over a time interval, as permitted under Section A8.4 (4), the attenuation required shall be 30 dB instead of 20 dB. Attenuation below the general field strength limits specified in RSS-Gen is not required.

## 8.2 Test Setup

The radiated emissions tests were performed in the 5-meter Chamber, using the setup in accordance with ANSI C63.4-2009. The specification used was the FCC 15 Subpart C and IC RSS-210 limits.

The spacing between the peripherals was 10 centimeters.

External I/O cables were draped along the edge of the test table and bundle when necessary.

## 8.3 Test Procedure

The measurements are base on FCC KDB 558074 D01 DTS Meas Guidance v03r02: Guidance for Performing Compliance Measurements on Digital Transmission Systems (DTS) Operating Under §15.247 section 11: Emissions in non-restricted frequency bands and section 12: Emissions in restricted frequency bands. As well as ANSI C63.4: 2009 as described below:

For the radiated emissions test, the EUT host, and all support equipment power cords was connected to the AC floor outlet.

Maximizing procedure was performed on the highest emissions to ensure that the EUT complied with all installation combinations.

The EUT is set 3 meter away from the testing antenna, which is varied from 1-4 meter, and the EUT is placed on a turntable, which is 0.8 meter above ground plane, the table shall be rotated for 360 degrees to find out the highest emission. The receiving antenna should be changed the polarization both of horizontal and vertical.

The spectrum analyzer or receiver is set as:

Below 1000 MHz:

RBW = 100 kHz / VBW = 300 kHz / Sweep = Auto

Above 1000 MHz:

- (1) Peak: RBW = 1MHz / VBW = 1MHz / Sweep = Auto
- (2) Average: RBW = 1MHz / VBW = 10Hz / Sweep = Auto

## 8.4 Corrected Amplitude & Margin Calculation

The Corrected Amplitude (CA) is calculated by adding the Antenna Factor (AF), the Cable Loss (CL), the Attenuator Factor (Atten) and subtracting the Amplifier Gain (Ga) to indicated Amplitude (Ai) reading. The basic equation is as follows:

$$CA = Ai + AF + CL + Atten - Ga$$

For example, a corrected amplitude of 40.3 dBuV/m = Indicated Reading (32.5 dBuV) + Antenna Factor (+23.5dB) + Cable Loss (3.7 dB) + Attenuator (10 dB) - Amplifier Gain (29.4 dB)

The “**Margin**” column of the following data tables indicates the degree of compliance within the applicable limit. For example, a margin of -7 dB means the emission is 7 dB below the maximum limit. The equation for margin calculation is as follows:

$$\text{Margin} = \text{Corrected Amplitude} - \text{Limit}$$

## 8.5 Test Equipment List and Details

Manufacturer	Description	Model No.	Serial No.	Calibration Date	Calibration Interval
Sunol Science Corp	System Controller	SC99V	122303-1	N/R	N/R
Sunol Science Corp	Combination Antenna	JB3	A020106-3	2014-07-24	1 year
Hewlett Packard	Pre-amplifier 1GHz-26.5GHz	8447D	2944A06639	2014-04-26	1 year
Agilent	Spectrum Analyzer	E4440A	MY44303352	2013-11-07	1 year
EMCO	Horn Antenna	3315	9511-4627	2013-10-17	1 year
Rohde & Schwarz	EMI Test Receiver	ESCI 1166.5950K03	100337	2013-10-28	1 year

**Statement of Traceability:** *BACL* attests that all calibrations have been performed per the A2LA requirements, traceable to NIST.

## 8.6 Test Environmental Conditions

<b>Temperature:</b>	22 °C
<b>Relative Humidity:</b>	52 %
<b>ATM Pressure:</b>	101.9 kPa

The testing was performed by Rui Zhou on 2014-10-03 in 5 m chamber 3.

## 8.7 Summary of Test Results

According to the data hereinafter, the EUT complied with the FCC Title 47, Part 15C standard's radiated emissions limits, and had the worst margin of:

### 30-1000 MHz:

Mode: Transmitting			
Margin (dB)	Frequency (MHz)	Polarization (Horizontal/Vertical)	Mode, Channel
-7.24	128.444	Vertical	802.11b mode middle Channel

### 1-26 GHz:

Mode: Transmitting			
Margin (dB)	Frequency (MHz)	Polarization (Horizontal/Vertical)	Mode, Channel
-0.04	2483.5	Horizontal	802.11 b mode High Channel

Please refer to the following table and plots for specific test result details

### 8.8 Radiated Emissions Test Results

#### 1) 30 MHz – 1 GHz

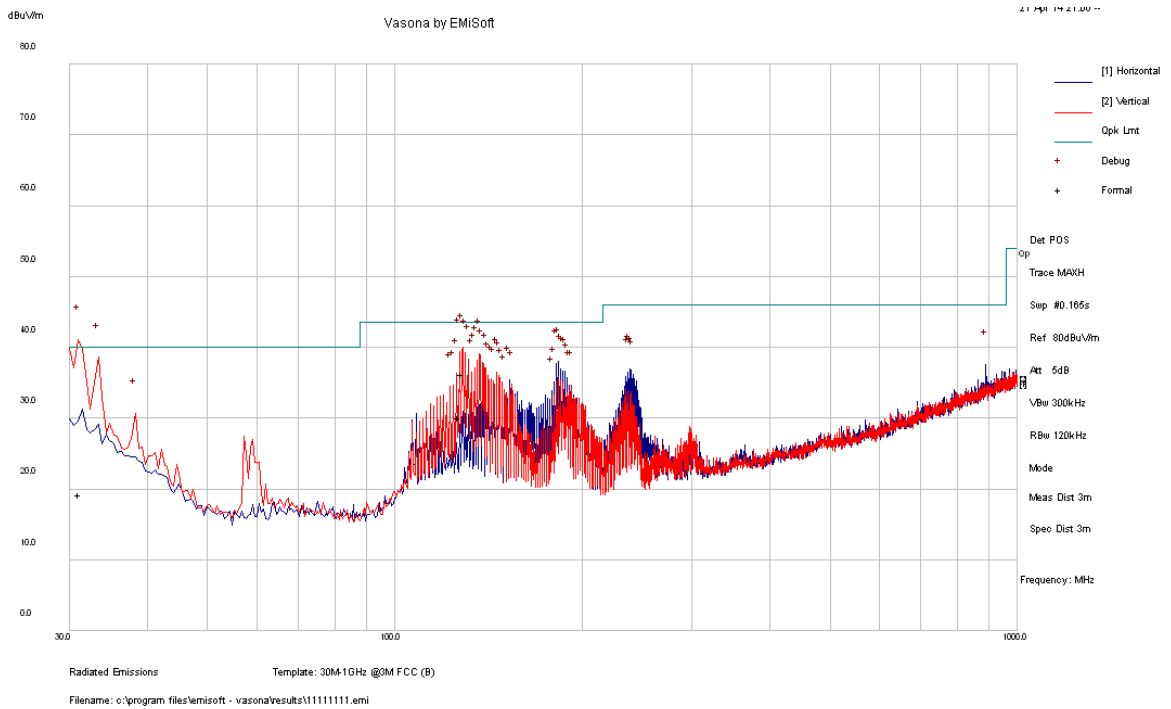

Frequency (MHz)	Corrected Amplitude (dBµV/m)	Antenna Height (cm)	Antenna Polarity (H/V)	Turntable Azimuth (degrees)	Limit (dBµV/m)	Margin (dB)
128.444	36.26	131	V	86	43.5	-7.24
126.9818	30.07	98	V	0	43.5	-13.43
31.12175	19.26	155	V	157	40	-20.74

Note: All 30 MHz – 1 GHz spurious are digital, other emissions are on the noise floor level. The worst case result as 2.4 GHz 802.11 b mode middle channel chain 0 with highest power was reported. Chain 1 need not be tested as Chain 0 is the worst case.

## 2) 1–26 GHz, Measured at 3 meters

## 802.11b mode

Frequency (MHz)	S.A. Reading (dBμV)	Turntable Azimuth (degrees)	Test Antenna			Cable Loss (dB)	Pre-Amp. (dB)	Cord. Reading (dBμV/m)	FCC/IC		Comments
			Height (cm)	Polarity (H/V)	Factor (dB/m)				Limit (dBμV/m)	Margin (dB)	
Low Channel 2412 MHz, measured at 3 meters											
2412	77.28	216	100	V	28.17	2.82	0	108.27	N/A	N/A	Peak
2412	77.78	317	100	H	28.17	2.82	0	108.77	N/A	N/A	Peak
2412	74.04	216	100	V	28.17	2.82	0	105.03	N/A	N/A	Ave
2412	74.52	317	100	H	28.17	2.82	0	105.51	N/A	N/A	Ave
2390	25.96	216	100	V	28.17	2.78	0	56.91	74	-17.09	Peak
2390	27.06	317	100	H	28.17	2.78	0	58.01	74	-15.99	Peak
2390	14.56	216	100	V	28.17	2.78	0	45.51	54	-8.49	Ave
2390	14.94	317	100	H	28.17	2.78	0	45.89	54	-8.11	Ave
4824	54.98	242	100	V	33.1	4.08	38.8	53.36	74	-20.64	Peak
4824	58.28	322	100	H	33.1	4.08	38.8	56.66	74	-17.34	Peak
4824	51.87	242	100	V	33.1	4.08	38.8	50.25	54	-3.75	Ave
4824	55.13	322	100	H	33.1	4.08	38.8	53.51	54	-0.49	Ave
7236	45.12	0	100	V	37.3	3.93	38.9	47.45	88.77	-41.32	Peak
7236	46.03	0	100	H	37.3	3.93	38.9	48.36	88.77	-40.41	Peak
7236	33.62	0	100	V	37.3	3.93	38.9	35.95	75.03	-39.08	Ave
7236	34.01	0	100	H	37.3	3.93	38.9	36.34	75.03	-38.69	Ave
9648	45.16	0	100	V	38.9	5.72	40	49.78	88.77	-38.99	Peak
9648	45.78	0	100	H	38.9	5.72	40	50.4	88.77	-38.37	Peak
9648	33.63	0	100	V	38.9	5.72	40	38.25	75.03	-36.78	Ave
9648	33.71	0	100	H	38.9	5.72	40	38.33	75.03	-36.7	Ave
Middle Channel 2437 MHz, measured at 3 meters											
2437	76.19	205	100	V	28.17	2.82	0	107.18	N/A	N/A	Peak
2437	77.72	316	100	H	28.17	2.82	0	108.71	N/A	N/A	Peak
2437	72.79	205	100	V	28.17	2.82	0	103.78	N/A	N/A	Ave
2437	74.07	316	100	H	28.17	2.82	0	105.06	N/A	N/A	Ave
4874	52.61	292	100	V	33.1	4.07	38.7	51.08	74	-22.92	Peak
4874	54.18	319	100	H	33.1	4.07	38.7	52.65	74	-21.35	Peak
4874	47.49	292	100	V	33.1	4.07	38.7	45.96	54	-8.04	Ave
4874	50.39	319	100	H	33.1	4.07	38.7	48.86	54	-5.14	Ave
7311	45.04	0	100	V	37.3	3.94	39.03	47.25	88.71	-41.46	Peak
7311	45.71	0	100	H	37.3	3.94	39.03	47.92	88.71	-40.79	Peak
7311	33.64	0	100	V	37.3	3.94	39.03	35.85	75.06	-39.21	Ave
7311	33.81	0	100	H	37.3	3.94	39.03	36.02	75.06	-39.04	Ave
9748	47.38	0	100	V	38.9	5.78	40.21	51.85	88.71	-36.86	Peak
9748	47.66	0	100	H	38.9	5.78	40.21	52.13	88.71	-36.58	Peak
9748	37.8	0	100	V	38.9	5.78	40.21	42.27	75.06	-32.79	Ave
9748	37.9	0	100	H	38.9	5.78	40.21	42.37	75.06	-32.69	Ave



Frequency (MHz)	S.A. Reading (dBμV)	Turntable Azimuth (degrees)	Test Antenna			Cable Loss (dB)	Pre-Amp. (dB)	Cord. Reading (dBμV/m)	FCC/IC		Comments
			Height (cm)	Polarity (H/V)	Factor (dB/m)				Limit (dBμV/m)	Margin (dB)	
High Channel 2462 MHz, measured at 3 meters											
2462	74.82	206	100	V	28.17	2.82	0	105.81	N/A	N/A	Peak
2462	76.85	317	100	H	28.17	2.82	0	107.84	N/A	N/A	Peak
2462	71.27	206	100	V	28.17	2.82	0	102.26	N/A	N/A	Ave
2462	73.48	317	100	H	28.17	2.82	0	104.47	N/A	N/A	Ave
2483.5	28.53	206	100	V	28.17	2.78	0	59.48	74	-14.52	Peak
2483.5	29.42	317	100	H	28.17	2.78	0	60.37	74	-13.63	Peak
2483.5	21.46	206	100	V	28.17	2.78	0	52.41	54	-1.59	Ave
2483.5	23.01	317	100	H	28.17	2.78	0	53.96	54	-0.04	Ave
4924	51.32	239	100	V	33.1	4.09	38.6	49.91	74	-24.09	Peak
4924	54.12	301	100	H	33.1	4.09	38.6	52.71	74	-21.29	Peak
4924	45.44	239	100	V	33.1	4.09	38.6	44.03	54	-9.97	Ave
4924	50.87	301	100	H	33.1	4.09	38.6	49.46	54	-4.54	Ave
7386	45.14	0	100	V	37.3	5.17	39.1	48.51	87.84	-39.33	Peak
7386	45.61	0	100	H	37.3	3.93	39.1	47.74	87.84	-40.1	Peak
7386	33.34	0	100	V	37.3	3.93	39.1	35.47	74.47	-39	Ave
7386	33.71	0	100	H	37.3	3.93	39.1	35.84	74.47	-38.63	Ave
9848	47.28	0	100	V	38.9	5.78	39.9	52.06	87.84	-35.78	Peak
9848	46.33	0	100	H	38.9	5.78	39.9	51.11	87.84	-36.73	Peak
9848	36.3	0	100	V	38.9	5.78	39.9	41.08	74.47	-33.39	Ave
9848	35.9	0	100	H	38.9	5.78	39.9	40.68	74.47	-33.79	Ave

## 802.11g mode

Frequency (MHz)	S.A. Reading (dBµV)	Turntable Azimuth (degrees)	Test Antenna			Cable Loss (dB)	Pre-Amp. (dB)	Cord. Reading (dBµV/m)	FCC/IC		Comments
			Height (cm)	Polarity (H/V)	Factor (dB/m)				Limit (dBµV/m)	Margin (dB)	
Low Channel 2412 MHz, measured at 3 meters											
2412	81.36	216	100	V	28.17	2.82	0	112.35	N/A	N/A	Peak
2412	81.25	318	100	H	28.17	2.82	0	112.24	N/A	N/A	Peak
2412	69.07	216	100	V	28.17	2.82	0	100.06	N/A	N/A	Ave
2412	69.72	318	100	H	28.17	2.82	0	100.71	N/A	N/A	Ave
2390	35.5	216	100	V	28.17	2.78	0	66.45	74	-7.55	Peak
2390	34.85	318	100	H	28.17	2.78	0	65.8	74	-8.2	Peak
2390	16.16	216	100	V	28.17	2.78	0	47.11	54	-6.89	Ave
2390	16.72	318	100	H	28.17	2.78	0	47.67	54	-6.33	Ave
4824	53.32	0	100	V	33.1	4.08	38.8	51.7	74	-22.3	Peak
4824	55.42	0	100	H	33.1	4.08	38.8	53.8	74	-20.2	Peak
4824	37.61	0	100	V	33.1	4.08	38.8	35.99	54	-18.01	Ave
4824	38.73	0	100	H	33.1	4.08	38.8	37.11	54	-16.89	Ave
7236	45.21	0	100	V	37.3	3.93	38.9	47.54	92.35	-44.81	Peak
7236	45.34	0	100	H	37.3	3.93	38.9	47.67	92.35	-44.68	Peak
7236	32.61	0	100	V	37.3	3.93	38.9	34.94	70.71	-35.77	Ave
7236	32.77	0	100	H	37.3	3.93	38.9	35.1	70.71	-35.61	Ave
9648	45.73	0	100	V	38.9	5.72	40	50.35	92.35	-42	Peak
9648	45.99	0	100	H	38.9	5.72	40	50.61	92.35	-41.74	Peak
9648	33.2	0	100	V	38.9	5.72	40	37.82	70.71	-32.89	Ave
9648	33.5	0	100	H	38.9	5.72	40	38.12	70.71	-32.59	Ave
Middle Channel 2437 MHz, measured at 3 meters											
2437	79.18	211	100	V	28.17	2.82	0	110.17	N/A	N/A	Peak
2437	80.02	318	100	H	28.17	2.82	0	111.01	N/A	N/A	Peak
2437	67.55	211	100	V	28.17	2.82	0	98.54	N/A	N/A	Ave
2437	69.54	318	100	H	28.17	2.82	0	100.53	N/A	N/A	Ave
4874	50.59	0	100	V	33.1	4.07	38.7	49.06	74	-24.94	Peak
4874	52.86	0	100	H	33.1	4.07	38.7	51.33	74	-22.67	Peak
4874	36.71	0	100	V	33.1	4.07	38.7	35.18	54	-18.82	Ave
4874	37.58	0	100	H	33.1	4.07	38.7	36.05	54	-17.95	Ave
7311	45.32	0	100	V	37.3	3.94	39.03	47.53	91.01	-43.48	Peak
7311	46.21	0	100	H	37.3	3.94	39.03	48.42	91.01	-42.59	Peak
7311	32.97	0	100	V	37.3	3.94	39.03	35.18	70.53	-35.35	Ave
7311	33.13	0	100	H	37.3	3.94	39.03	35.34	70.53	-35.19	Ave
9748	45.79	0	100	V	38.9	5.78	40.21	50.26	91.01	-40.75	Peak
9748	46.29	0	100	H	38.9	5.78	40.21	50.76	91.01	-40.25	Peak
9748	33.71	0	100	V	38.9	5.78	40.21	38.18	70.53	-32.35	Ave
9748	33.83	0	100	H	38.9	5.78	40.21	38.3	70.53	-32.23	Ave

Frequency (MHz)	S.A. Reading (dB $\mu$ V)	Turntable Azimuth (degrees)	Test Antenna			Cable Loss (dB)	Pre-Amp. (dB)	Cord. Reading (dB $\mu$ V/m)	FCC/IC		Comments
			Height (cm)	Polarity (H/V)	Factor (dB/m)				Limit (dB $\mu$ V/m)	Margin (dB)	
High Channel 2462 MHz, measured at 3 meters											
2462	77.43	206	100	V	28.17	2.82	0	108.42	N/A	N/A	Peak
2462	78.79	318	100	H	28.17	2.82	0	109.78	N/A	N/A	Peak
2462	66.11	206	100	V	28.17	2.82	0	97.1	N/A	N/A	Ave
2462	67.96	318	100	H	28.17	2.82	0	98.95	N/A	N/A	Ave
2483.5	42.81	206	100	V	28.17	2.78	0	73.76	74	-0.24	Peak
2483.5	42.84	318	100	H	28.17	2.78	0	73.79	74	-0.21	Peak
2483.5	21.09	206	100	V	28.17	2.78	0	52.04	54	-1.96	Ave
2483.5	22.35	318	100	H	28.17	2.78	0	53.3	54	-0.7	Ave
4924	49.49	0	100	V	33.1	4.09	38.6	48.08	74	-25.92	Peak
4924	52.47	0	100	H	33.1	4.09	38.6	51.06	74	-22.94	Peak
4924	34.21	0	100	V	33.1	4.09	38.6	32.8	54	-21.2	Ave
4924	36.6	0	100	H	33.1	4.09	38.6	35.19	54	-18.81	Ave
7386	45.22	0	100	V	37.3	5.17	39.1	48.59	89.78	-41.19	Peak
7386	46.01	0	100	H	37.3	3.93	39.1	48.14	89.78	-41.64	Peak
7386	33.24	0	100	V	37.3	3.93	39.1	35.37	68.95	-33.58	Ave
7386	34.01	0	100	H	37.3	3.93	39.1	36.14	68.95	-32.81	Ave
9848	46.68	0	100	V	38.9	5.78	39.9	51.46	89.78	-38.32	Peak
9848	47.05	0	100	H	38.9	5.78	39.9	51.83	89.78	-37.95	Peak
9848	34.05	0	100	V	38.9	5.78	39.9	38.83	68.95	-30.12	Ave
9848	34.51	0	100	H	38.9	5.78	39.9	39.29	68.95	-29.66	Ave

**802.11n-HT20 mode**

Frequency (MHz)	S.A. Reading (dBµV)	Turntable Azimuth (degrees)	Test Antenna			Cable Loss (dB)	Pre-Amp. (dB)	Cord. Reading (dBµV/m)	FCC/IC		Comments
			Height (cm)	Polarity (H/V)	Factor (dB/m)				Limit (dBµV/m)	Margin (dB)	
Low Channel 2412 MHz, measured at 3 meters											
2412	81.07	215	100	V	28.17	2.82	0	112.06	N/A	N/A	Peak
2412	81.47	316	100	H	28.17	2.82	0	112.46	N/A	N/A	Peak
2412	69.53	215	100	V	28.17	2.82	0	100.52	N/A	N/A	Ave
2412	69.28	316	100	H	28.17	2.82	0	100.27	N/A	N/A	Ave
2390	35.4	215	100	V	28.17	2.78	0	66.35	74	-7.65	Peak
2390	37.51	316	100	H	28.17	2.78	0	68.46	74	-5.54	Peak
2390	15.64	215	100	V	28.17	2.78	0	46.59	54	-7.41	Ave
2390	15.51	316	100	H	28.17	2.78	0	46.46	54	-7.54	Ave
4824	52.14	0	100	V	33.1	4.08	38.8	50.52	74	-23.48	Peak
4824	53.24	0	100	H	33.1	4.08	38.8	51.62	74	-22.38	Peak
4824	37.31	0	100	V	33.1	4.08	38.8	35.69	54	-18.31	Ave
4824	38.04	0	100	H	33.1	4.08	38.8	36.42	54	-17.58	Ave
7236	45.77	0	100	V	37.3	3.93	38.9	48.1	92.46	-44.36	Peak
7236	46.03	0	100	H	37.3	3.93	38.9	48.36	92.46	-44.1	Peak
7236	33.9	0	100	V	37.3	3.93	38.9	36.23	70.52	-34.29	Ave
7236	34.1	0	100	H	37.3	3.93	38.9	36.43	70.52	-34.09	Ave
9648	45.36	0	100	V	38.9	5.72	40	49.98	92.46	-42.48	Peak
9648	45.87	0	100	H	38.9	5.72	40	50.49	92.46	-41.97	Peak
9648	33.45	0	100	V	38.9	5.72	40	38.07	70.52	-32.45	Ave
9648	33.78	0	100	H	38.9	5.72	40	38.4	70.52	-32.12	Ave
Middle Channel 2437 MHz, measured at 3 meters											
2437	80.93	217	100	V	28.17	2.82	0	111.92	N/A	N/A	Peak
2437	80.58	317	100	H	28.17	2.82	0	111.57	N/A	N/A	Peak
2437	69.09	217	100	V	28.17	2.82	0	100.08	N/A	N/A	Ave
2437	69.56	317	100	H	28.17	2.82	0	100.55	N/A	N/A	Ave
4874	52.59	0	100	V	33.1	4.08	38.7	51.07	74	-22.93	Peak
4874	53.74	0	100	H	33.1	4.08	38.7	52.22	74	-21.78	Peak
4874	35.12	0	100	V	33.1	4.08	38.7	33.6	54	-20.4	Ave
4874	35.63	0	100	H	33.1	4.08	38.7	34.11	54	-19.89	Ave
7311	45.69	0	100	V	37.3	3.93	39.03	47.89	91.92	-44.03	Peak
7311	46.32	0	100	H	37.3	3.93	39.03	48.52	91.92	-43.4	Peak
7311	33.41	0	100	V	37.3	3.93	39.03	35.61	70.55	-34.94	Ave
7311	33.85	0	100	H	37.3	3.93	39.03	36.05	70.55	-34.5	Ave
9748	46.3	0	100	V	38.9	5.72	40.21	50.71	91.92	-41.21	Peak
9748	46.8	0	100	H	38.9	5.72	40.21	51.21	91.92	-40.71	Peak
9748	34.07	0	100	V	38.9	5.72	40.21	38.48	70.55	-32.07	Ave
9748	34.51	0	100	H	38.9	5.72	40.21	38.92	70.55	-31.63	Ave

Frequency (MHz)	S.A. Reading (dB $\mu$ V)	Turntable Azimuth (degrees)	Test Antenna			Cable Loss (dB)	Pre-Amp. (dB)	Cord. Reading (dB $\mu$ V/m)	FCC/IC		Comments
			Height (cm)	Polarity (H/V)	Factor (dB/m)				Limit (dB $\mu$ V/m)	Margin (dB)	
High Channel 2462 MHz, measured at 3 meters											
2462	78.36	201	100	V	28.17	2.82	0	109.35	N/A	N/A	Peak
2462	78.57	318	100	H	28.17	2.82	0	109.56	N/A	N/A	Peak
2462	67.26	201	100	V	28.17	2.82	0	98.25	N/A	N/A	Ave
2462	65.71	318	100	H	28.17	2.82	0	96.7	N/A	N/A	Ave
2483.5	42.27	201	100	V	28.17	2.78	0	73.22	74	-0.78	Peak
2483.5	43.01	318	100	H	28.17	2.78	0	73.96	74	-0.04	Peak
2483.5	19.63	201	100	V	28.17	2.78	0	50.58	54	-3.42	Ave
2483.5	20.64	318	100	H	28.17	2.78	0	51.59	54	-2.41	Ave
4924	49.21	0	100	V	33.1	4.08	38.6	47.79	74	-26.21	Peak
4924	50.31	0	100	H	33.1	4.08	38.6	48.89	74	-25.11	Peak
4924	34.57	0	100	V	33.1	4.08	38.6	33.15	54	-20.85	Ave
4924	35.77	0	100	H	33.1	4.08	38.6	34.35	54	-19.65	Ave
7386	46.17	0	100	V	37.3	3.93	39.1	48.3	89.56	-41.26	Peak
7386	47.09	0	100	H	37.3	3.93	39.1	49.22	89.56	-40.34	Peak
7386	33.04	0	100	V	37.3	3.93	39.1	35.17	68.25	-33.08	Ave
7386	33.55	0	100	H	37.3	3.93	39.1	35.68	68.25	-32.57	Ave
9848	46.22	0	100	V	38.9	5.72	39.9	50.94	89.56	-38.62	Peak
9848	46.89	0	100	H	38.9	5.72	39.9	51.61	89.56	-37.95	Peak
9848	33.93	0	100	V	38.9	5.72	39.9	38.65	68.25	-29.6	Ave
9848	34.15	0	100	H	38.9	5.72	39.9	38.87	68.25	-29.38	Ave

**802.11n-HT40 mode**

Frequency (MHz)	S.A. Reading (dBµV)	Turntable Azimuth (degrees)	Test Antenna			Cable Loss (dB)	Pre-Amp. (dB)	Cord. Reading (dBµV/m)	FCC/IC		Comments
			Height (cm)	Polarity (H/V)	Factor (dB/m)				Limit (dBµV/m)	Margin (dB)	
Low Channel 2412 MHz, measured at 3 meters											
2422	77.83	209	100	V	28.17	2.82	0	108.82	N/A	N/A	Peak
2422	77.88	319	100	H	28.17	2.82	0	108.87	N/A	N/A	Peak
2422	65.06	209	100	V	28.17	2.82	0	96.05	N/A	N/A	Ave
2422	65.01	319	100	H	28.17	2.82	0	96	N/A	N/A	Ave
2390	41.75	209	100	V	28.17	2.78	0	72.7	74	-1.3	Peak
2390	42.5	319	100	H	28.17	2.78	0	73.45	74	-0.55	Peak
2390	19.18	209	100	V	28.17	2.78	0	50.13	54	-3.87	Ave
2390	19.74	319	100	H	28.17	2.78	0	50.69	54	-3.31	Ave
4844	46.13	0	100	V	33.1	4.08	38.7	44.61	74	-29.39	Peak
4844	46.4	0	100	H	33.1	4.08	38.7	44.88	74	-29.12	Peak
4844	33.8	0	100	V	33.1	4.08	38.7	32.28	54	-21.72	Ave
4844	34.1	0	100	H	33.1	4.08	38.7	32.58	54	-21.42	Ave
7266	44.15	0	100	V	37.3	3.93	38.9	46.48	88.87	-42.39	Peak
7266	44.73	0	100	H	37.3	3.93	38.9	47.06	88.87	-41.81	Peak
7266	32.19	0	100	V	37.3	3.93	38.9	34.52	66.05	-31.53	Ave
7266	32.66	0	100	H	37.3	3.93	38.9	34.99	66.05	-31.06	Ave
9688	45.77	0	100	V	38.9	5.72	40.1	50.29	88.87	-38.58	Peak
9688	46.88	0	100	H	38.9	5.72	40.1	51.4	88.87	-37.47	Peak
9688	33.28	0	100	V	38.9	5.72	40.1	37.8	66.05	-28.25	Ave
9688	33.64	0	100	H	38.9	5.72	40.1	38.16	66.05	-27.89	Ave
Middle Channel 2437 MHz, measured at 3 meters											
2437	77.82	217	100	V	28.17	2.82	0	108.81	N/A	N/A	Peak
2437	78.01	317	100	H	28.17	2.82	0	109	N/A	N/A	Peak
2437	65.75	217	100	V	28.17	2.82	0	96.74	N/A	N/A	Ave
2437	65.77	317	100	H	28.17	2.82	0	96.76	N/A	N/A	Ave
4874	46.97	0	100	V	33.1	4.08	38.7	45.45	74	-28.55	Peak
4874	47.03	0	100	H	33.1	4.08	38.7	45.51	74	-28.49	Peak
4874	34.34	0	100	V	33.1	4.08	38.7	32.82	54	-21.18	Ave
4874	35.02	0	100	H	33.1	4.08	38.7	33.5	54	-20.5	Ave
7311	46.15	0	100	V	37.3	3.93	39.03	48.35	89	-40.65	Peak
7311	46.89	0	100	H	37.3	3.93	39.03	49.09	89	-39.91	Peak
7311	32.78	0	100	V	37.3	3.93	39.03	34.98	66.76	-31.78	Ave
7311	33.11	0	100	H	37.3	3.93	39.03	35.31	66.76	-31.45	Ave
9748	46.24	0	100	V	38.9	5.72	40.21	50.65	89	-38.35	Peak
9748	46.98	0	100	H	38.9	5.72	40.21	51.39	89	-37.61	Peak
9748	34.09	0	100	V	38.9	5.72	40.21	38.5	66.76	-28.26	Ave
9748	34.53	0	100	H	38.9	5.72	40.21	38.94	66.76	-27.82	Ave

Frequency (MHz)	S.A. Reading (dB $\mu$ V)	Turntable Azimuth (degrees)	Test Antenna			Cable Loss (dB)	Pre-Amp. (dB)	Cord. Reading (dB $\mu$ V/m)	FCC/IC		Comments
			Height (cm)	Polarity (H/V)	Factor (dB/m)				Limit (dB $\mu$ V/m)	Margin (dB)	
High Channel 2462 MHz, measured at 3 meters											
2452	74.15	202	100	V	28.17	2.82	0	105.14	N/A	N/A	Peak
2452	73.02	318	100	H	28.17	2.82	0	104.01	N/A	N/A	Peak
2452	61.44	202	100	V	28.17	2.82	0	92.43	N/A	N/A	Ave
2452	60.76	318	100	H	28.17	2.82	0	91.75	N/A	N/A	Ave
2483.5	42.73	202	100	V	28.17	2.78	0	73.68	74	-0.32	Peak
2483.5	42.61	318	100	H	28.17	2.78	0	73.56	74	-0.44	Peak
2483.5	21.38	202	100	V	28.17	2.78	0	52.33	54	-1.67	Ave
2483.5	22.11	318	100	H	28.17	2.78	0	53.06	54	-0.94	Ave
4904	48.28	0	100	V	33.1	4.08	38.6	46.86	74	-27.14	Peak
4904	49.91	0	100	H	33.1	4.08	38.6	48.49	74	-25.51	Peak
4904	33.74	0	100	V	33.1	4.08	38.6	32.32	54	-21.68	Ave
4904	34.19	0	100	H	33.1	4.08	38.6	32.77	54	-21.23	Ave
7356	44.67	0	100	V	37.3	3.93	38.9	47	85.14	-38.14	Peak
7356	44.87	0	100	H	37.3	3.93	38.9	47.2	85.14	-37.94	Peak
7356	31.11	0	100	V	37.3	3.93	38.9	33.44	62.43	-28.99	Ave
7356	31.1	0	100	H	37.3	3.93	38.9	33.43	62.43	-29	Ave
9808	46.4	0	100	V	38.9	5.72	39.9	51.12	85.14	-34.02	Peak
9808	46.9	0	100	H	38.9	5.72	39.9	51.62	85.14	-33.52	Peak
9808	31.36	0	100	V	38.9	5.72	39.9	36.08	62.43	-26.35	Ave
9808	31.38	0	100	H	38.9	5.72	39.9	36.1	62.43	-26.33	Ave

## 9 FCC§15.247(a)(2) & IC RSS-210 §A8.2 – 6 dB & 99% Emission Bandwidth

### 9.1 Applicable Standard

According to FCC §15.247(a)(2) and IC RSS-210 A8.2 (a), systems using digital modulation techniques may operate in the 902~928 MHz, 2400~2483.5 MHz, and 5725~5850 MHz bands. The minimum 6 dB bandwidth shall be at least 500 kHz

### 9.2 Measurement Procedure

The measurements are base on FCC KDB 558074 D01 DTS Meas Guidance v03r02: Guidance for Performing Compliance Measurements on Digital Transmission Systems (DTS) Operating Under §15.247 section 8: DTS bandwidth

### 9.3 Test Equipment List and Details

Manufacturer	Description	Model No.	Serial No.	Calibration Date	Calibration Interval
Agilent	Spectrum Analyzer	E4440A	MY44303352	2013-11-07	1 year

*Statement of Traceability: BACL Corp. attests that all calibrations have been performed per the A2LA requirements, traceable to the NIST.*

### 9.4 Test Environmental Conditions

<b>Temperature:</b>	22-24 °C
<b>Relative Humidity:</b>	42-45 %
<b>ATM Pressure:</b>	101-102 kPa

*The testing was performed by Rui Zhou from 2014-10-03 and 2014-10-07 at RF site.*



**9.5 Test Results and Plots**

Channel	Frequency (MHz)	6 dB Emission Bandwidth (MHz) J0	6 dB Emission Bandwidth (MHz) J1	99% Emission Bandwidth (MHz) J0	99% Emission Bandwidth (MHz) J1	Limit (MHz)	Results
802.11b mode							
Low	2412	8.126	8.586	10.0832	10.2561	> 0.5	Compliant
Middle	2437	8.089	8.148	10.0891	10.3236	> 0.5	Compliant
High	2462	8.108	8.571	10.1663	10.3006	> 0.5	Compliant
802.11g mode							
Low	2412	14.687	16.021	16.2824	16.59	> 0.5	Compliant
Middle	2437	13.808	16.044	16.2498	16.63	> 0.5	Compliant
High	2462	14.7	16.352	16.2712	16.6	> 0.5	Compliant
802.11n-HT20 mode							
Low	2412	15.053	16.893	17.3776	17.4575	> 0.5	Compliant
Middle	2437	16.103	17.336	17.6951	17.4975	> 0.5	Compliant
High	2462	15.479	15.477	17.3886	17.5654	> 0.5	Compliant
802.11n-HT40 mode							
Low	2422	35.77	33.347	36.0188	35.9811	> 0.5	Compliant
Middle	2437	35.813	35.107	36.02	36.0853	> 0.5	Compliant
High	2452	36.358	35.359	36.1481	36.0111	> 0.5	Compliant

Please refer to the following plots for detailed test results

802.11 b mode

Low channel: 2412 MHz Chain J0

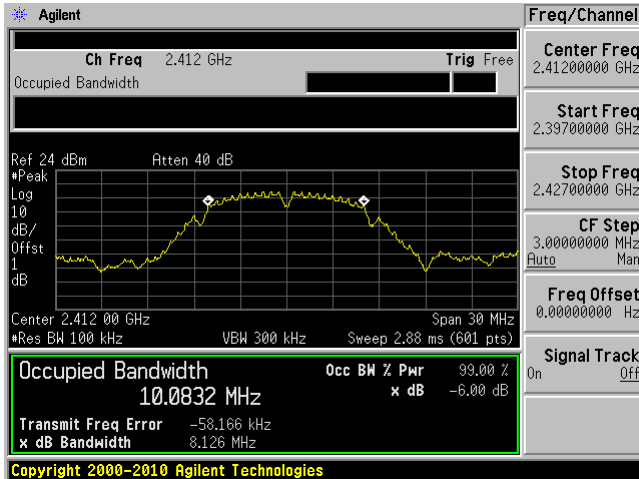

Low channel: 2412 MHz Chain J1

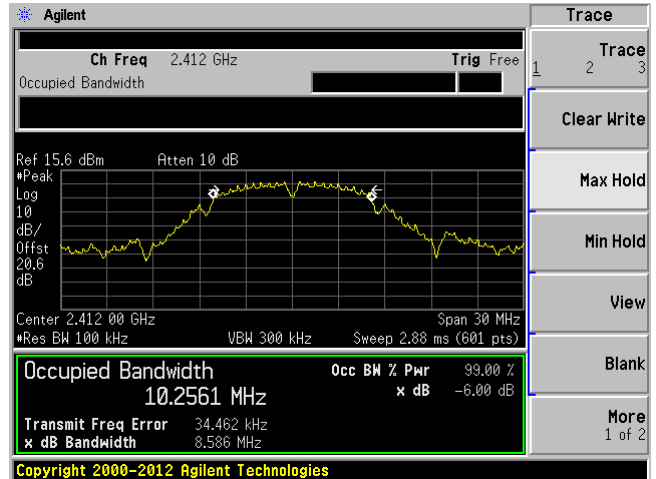

Middle channel: 2437 MHz Chain J0

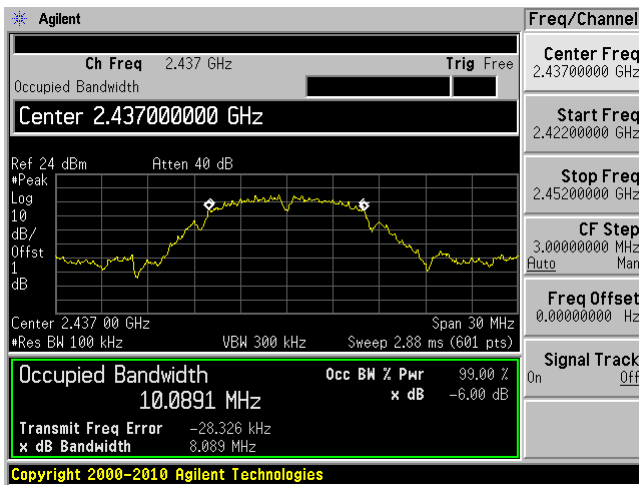

Middle channel: 2437 MHz Chain J1

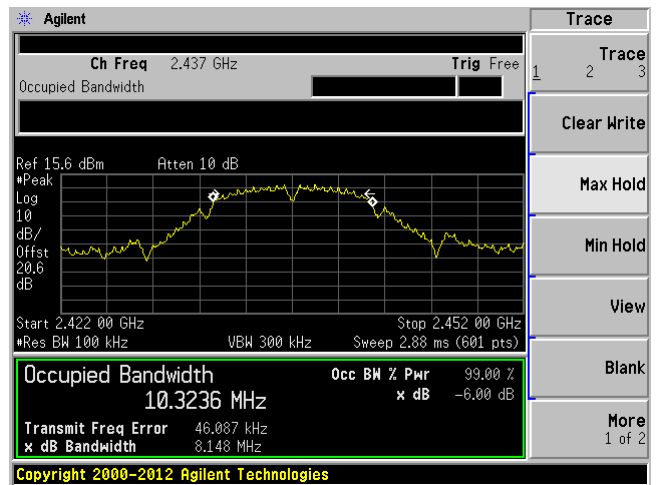

High channel: 2462 MHz Chain J0

High channel: 2462 MHz Chain J1

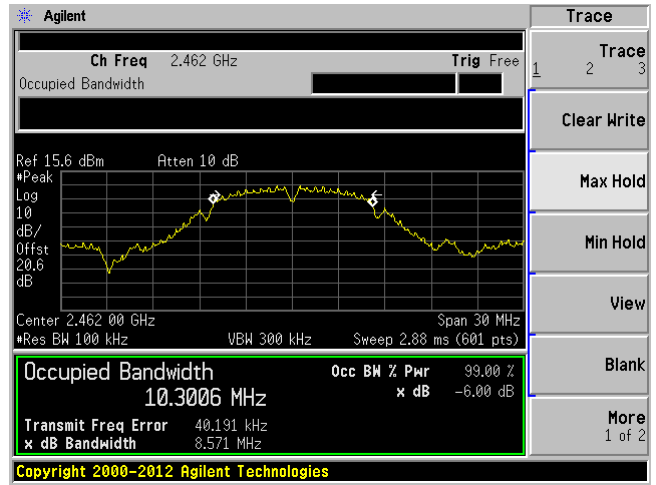
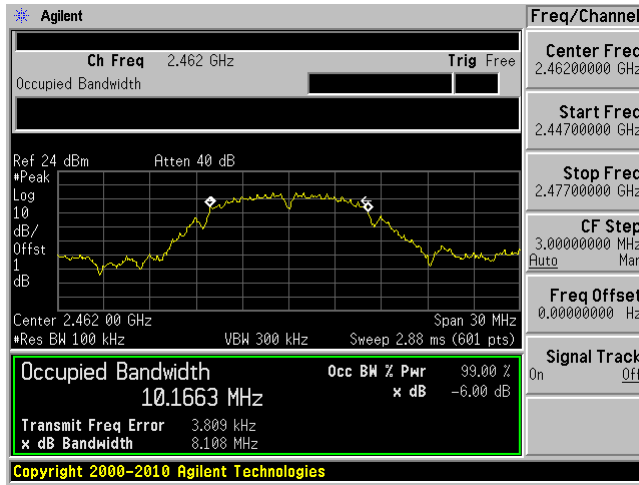

802.11 g mode

Low channel: 2412 MHz Chain J0

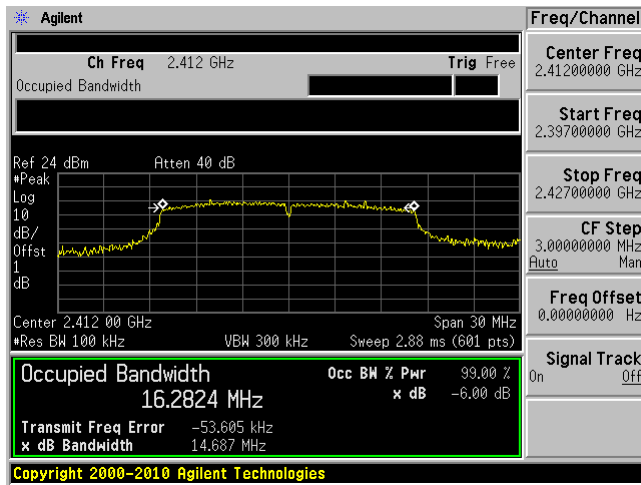

Low channel: 2412 MHz Chain J1

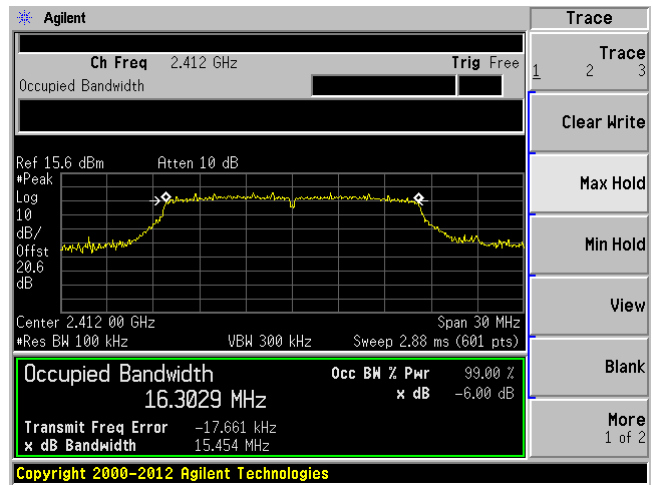

Middle channel: 2437 MHz Chain J0

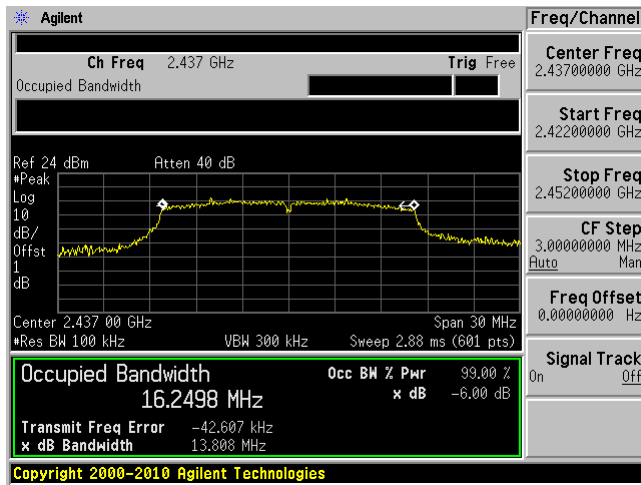

Middle channel: 2437 MHz Chain J1

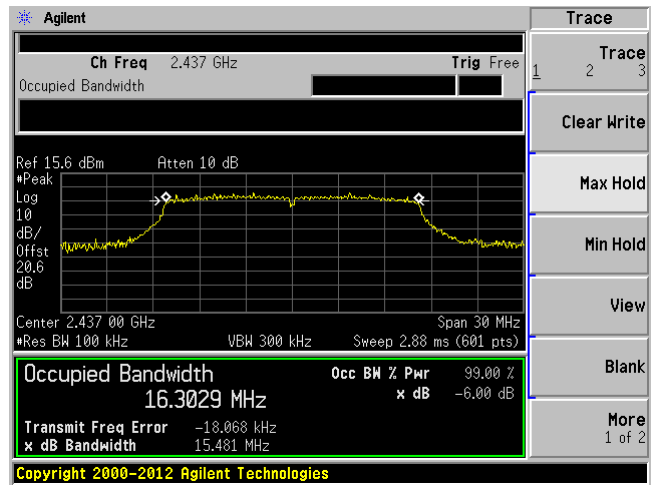

High channel: 2462 MHz Chain J0

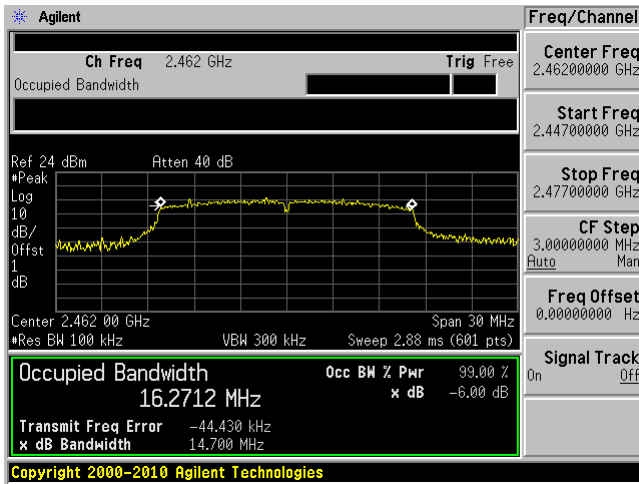

High channel: 2462 MHz Chain J1

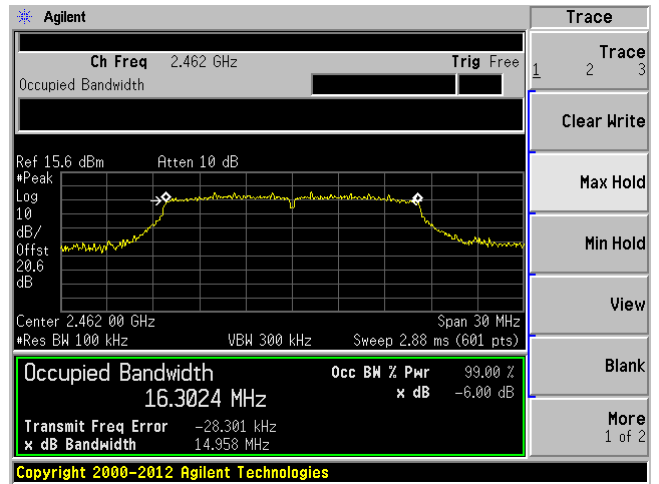

802.11n-HT20 mode

Low channel: 2412 MHz Chain J0

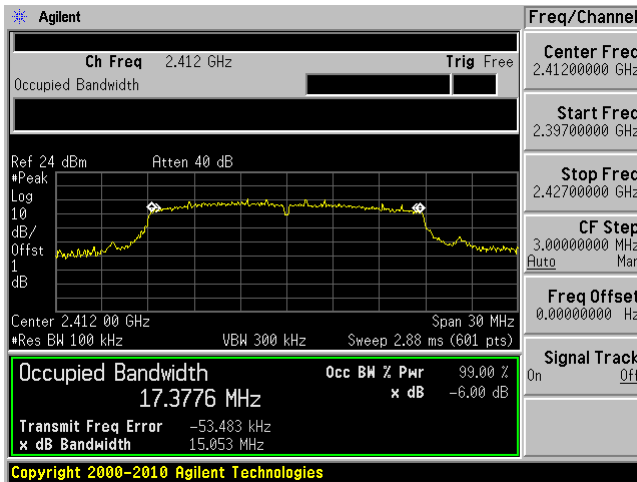

Low channel: 2412 MHz Chain J1

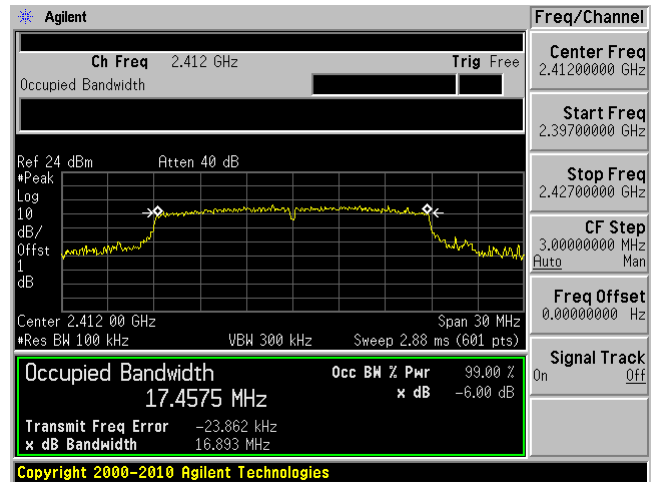

Middle channel: 2437 MHz Chain J0

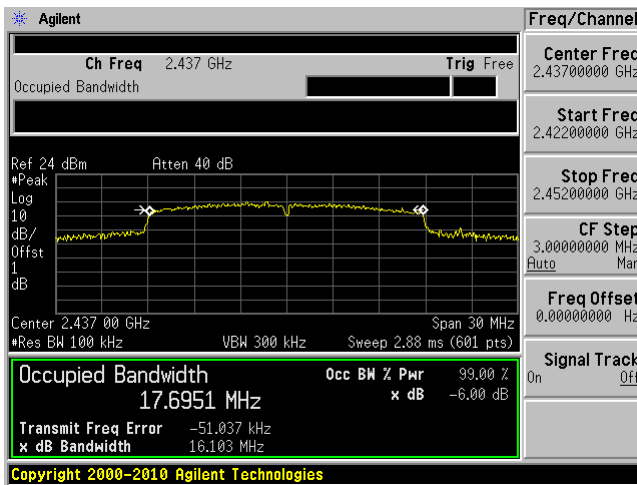

Middle channel: 2437 MHz Chain J1

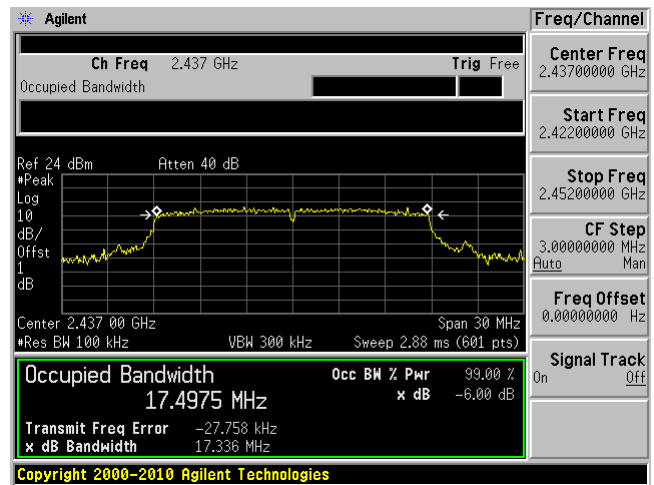

High channel: 2462 MHz Chain J0

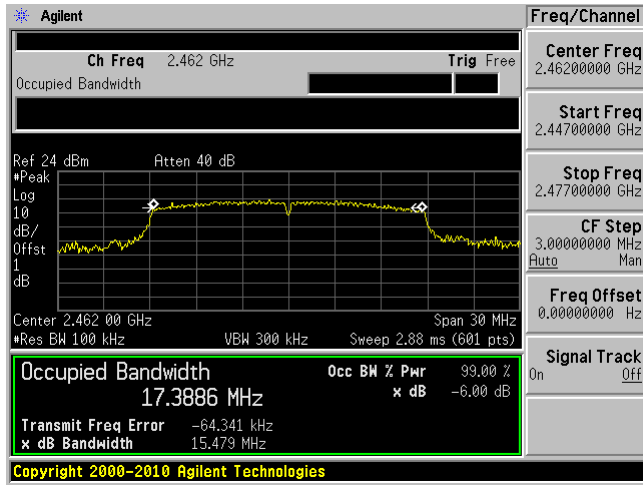

High channel: 2462 MHz Chain J1

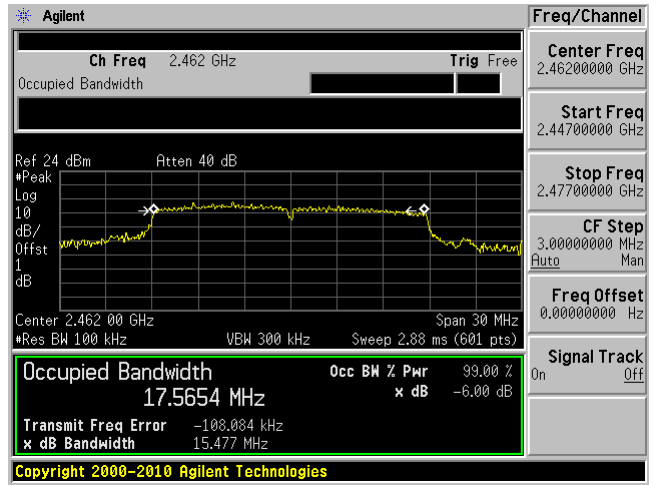

802.11n-HT40 mode

Low channel: 2422 MHz Chain J0

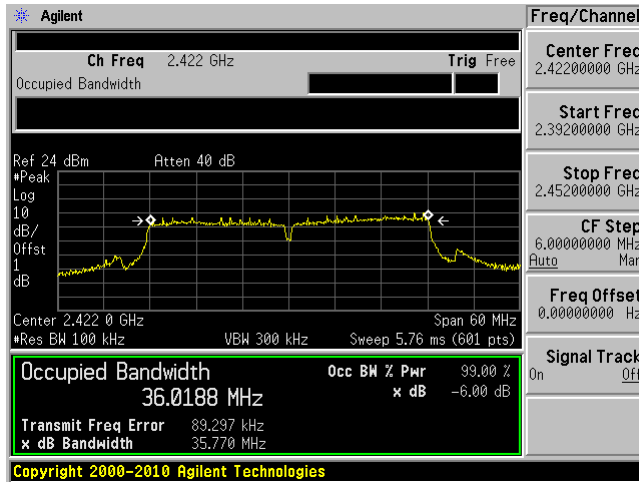

Low channel: 2422 MHz Chain J1

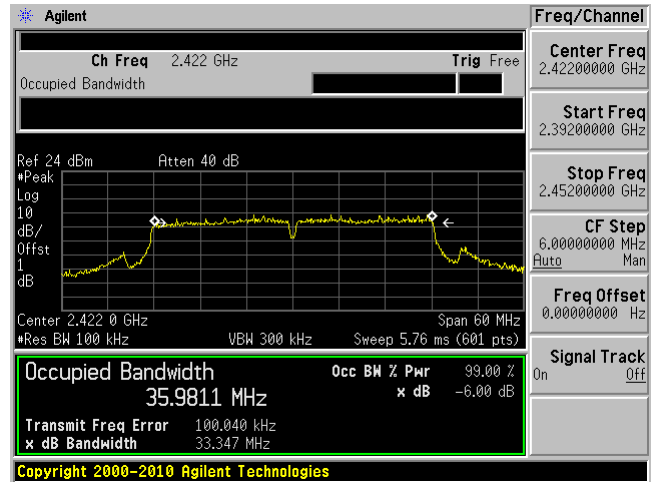

Middle channel: 2437 MHz Chain J0

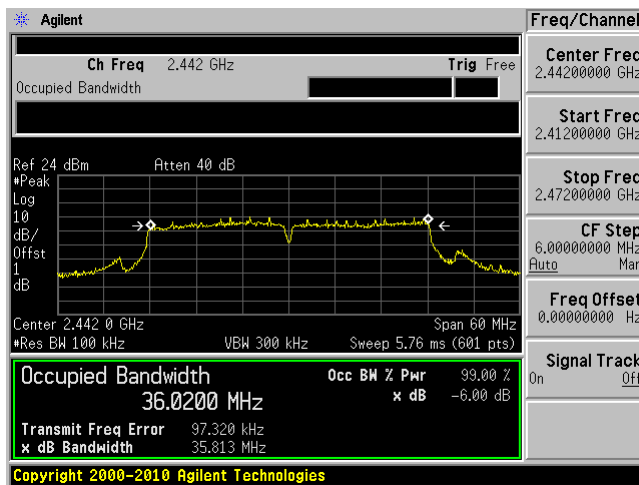

Middle channel: 2437 MHz Chain J1

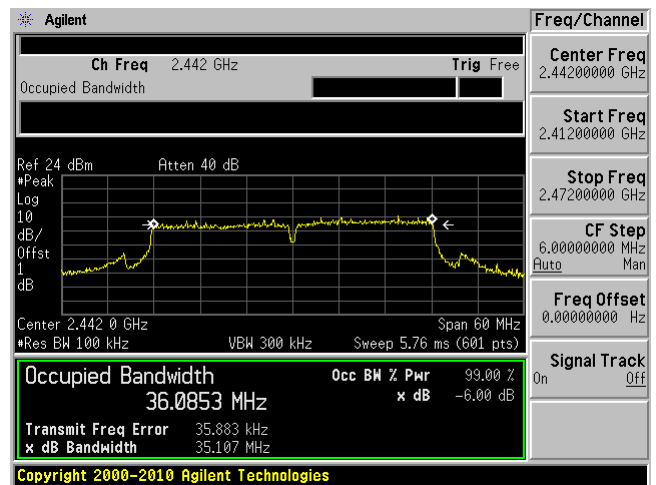



High channel: 2452 MHz Chain J0

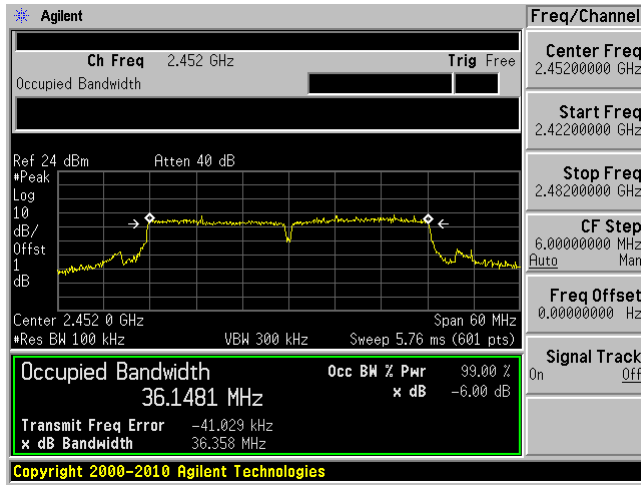

High channel: 2452 MHz Chain J1

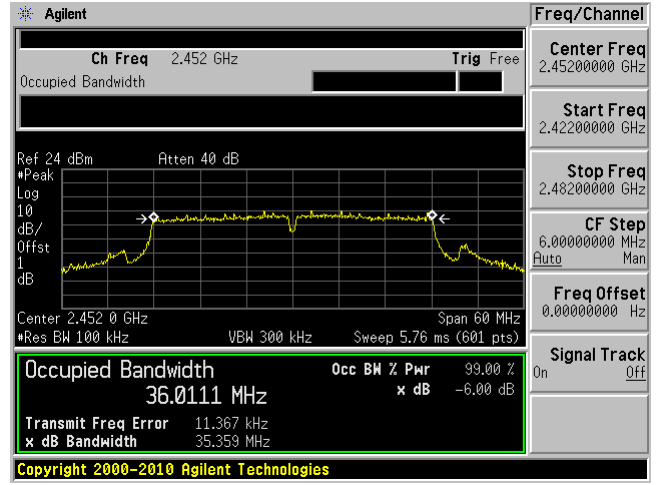

## 10 FCC §15.247(b) & IC RSS-210 §A8.4 (4) – Output Power Measurement

### 10.1 Applicable Standard

According to FCC §15.247(b) and IC RSS-210 §A8.4 (4) for systems using digital modulation in the 902~928 MHz, 2400~2483.5 MHz, and 5725~5850 MHz bands: 1 Watt.

### 10.2 Measurement Procedure

The measurements are base on FCC KDB 558074 D01 DTS Meas Guidance v03r02: Guidance for Performing Compliance Measurements on Digital Transmission Systems (DTS) Operating Under §15.247 section 9: Fundamental emission output power

### 10.3 Test Equipment List and Details

Manufacturer	Description	Model No.	Serial No.	Calibration Date	Calibration Interval
Agilent	Spectrum Analyzer	E4440A	MY44303352	2013-11-07	1 year

*Statement of Traceability: BACL Corp. attests that all calibrations have been performed per the A2LA requirements, traceable to the NIST.*

### 10.4 Test Environmental Conditions

<b>Temperature:</b>	22-24 °C
<b>Relative Humidity:</b>	42-45 %
<b>ATM Pressure:</b>	101-102 kPa

*The testing was performed by Rui Zhou from 2014-10-03 and 2014-10-06 at RF site.*

### 10.5 Test Results

#### Average Output Power

Channel	Frequency (MHz)	Conducted Average Output Power (dBm)		Max Output Power (dBm)	Limit (dBm)	Result	Power Setting
		Chain J0	Chain J1				
802.11b mode							
Low	2412	17.14	12.63	17.14	30	Pass	64
Middle	2437	17.86	12.88	17.86	30	Pass	64
High	2462	14.71	12.67	14.71	30	Pass	60
802.11g mode							
Low	2412	16.66	11.48	16.66	30	Pass	64
Middle	2437	17.51	11.92	17.51	30	Pass	64
High	2462	14.79	10.97	14.79	30	Pass	58

Channel	Frequency (MHz)	Conducted Average Output Power (dBm)		Total Output Power (dBm)	Limit (dBm)	Result	Power Setting
		Chain J0	Chain J1				
802.11n-HT20 mode							
Low	2412	15.28	12.45	17.10	30	Pass	72/60
Middle	2437	16.17	12.87	17.84	30	Pass	72/60
High	2462	13.63	13.12	16.39	30	Pass	66/60
802.11n-HT40 mode							
Low	2422	14.93	12.37	16.85	30	Pass	70/60
Middle	2437	15.78	12.81	17.55	30	Pass	72/60
High	2452	12.08	9.09	13.85	30	Pass	60/52

**Peak Output Power**

Channel	Frequency (MHz)	Conducted Peak Output Power (dBm)		Max Output Power (dBm)	Limit (dBm)	Result	Power Setting
		Chain J0	Chain J1				
802.11b mode							
Low	2412	20.24	14.92	20.24	30	Pass	64
Middle	2437	20.35	15.77	20.35	30	Pass	64
High	2462	17.89	15.55	17.89	30	Pass	60
802.11g mode							
Low	2412	22.58	19.38	22.58	30	Pass	64
Middle	2437	22.67	19.81	22.67	30	Pass	64
High	2462	20.12	18.84	20.12	30	Pass	58

Channel	Frequency (MHz)	Conducted Peak Output Power (dBm)		Total Output Power (dBm)	Limit (dBm)	Result	Power Setting
		Chain J0	Chain J1				
802.11n-HT20 mode							
Low	2412	21.39	18.92	23.34	30	Pass	72/60
Middle	2437	22.03	19.04	23.80	30	Pass	72/60
High	2462	19.54	17.25	21.55	30	Pass	66/60
802.11n-HT40 mode							
Low	2422	20.95	17.70	22.63	30	Pass	70/60
Middle	2437	21.83	17.87	23.30	30	Pass	72/60
High	2452	18.12	13.79	19.48	30	Pass	60/52

## 11 FCC §15.247(d) & IC RSS-210 §A8.5 – 100 kHz Bandwidth of Band Edges

### 11.1 Applicable Standard

According to FCC §15.247(d), in any 100 kHz bandwidth outside the frequency bands in which the spread spectrum intentional radiator is operating, the radio frequency power that is produced by the intentional radiator shall be at least 20 dB below that in the 100 kHz bandwidth within the band that contains the highest level of the desired power, based on either an RF conducted or a radiated measurement. In addition, radiated emissions which fall in the restricted bands, as defined in §15.205(a), must also comply with the radiated emissions limits specified in §15.209(a) see §15.205(c).

According to IC Rss-210 §A8.5, in any 100 kHz bandwidth outside the frequency band in which the spread spectrum or digitally modulated device is operating, the radio frequency power that is produced shall be at least 20 dB below that in the 100 kHz bandwidth within the band that contains the highest level of the desired power, based on either an RF conducted or a radiated measurement, provided the transmitter demonstrates compliance with the peak conducted power limits. If the transmitter complies with the conducted power limits based on the use of RMS averaging over a time interval, as permitted under section A8.4(4), the attenuation required shall be 30 dB instead of 20 dB. Attenuation below the general limits specified in Tables 2 and 3 is not required.

### 11.2 Measurement Procedure

The measurements are base on FCC KDB 558074 D01 DTS Meas Guidance v03r01: Guidance for Performing Compliance Measurements on Digital Transmission Systems (DTS) Operating Under §15.247 section 13: Band-edge measurements

### 11.3 Test Equipment List and Details

Manufacturer	Description	Model No.	Serial No.	Calibration Date	Calibration Interval
Agilent	Spectrum Analyzer	E4440A	MY44303352	2013-11-07	1 year

*Statement of Traceability: BACL Corp. attests that all calibrations have been performed per the A2LA requirements, traceable to the NIST.*

### 11.4 Test Environmental Conditions

Temperature:	22-24 °C
Relative Humidity:	42-45 %
ATM Pressure:	101-102 kPa

*The testing was performed by Rui Zhou from 2014-10-03 and 2014-10-06 at RF site.*

### 11.5 Test Results

Please refer to following pages for plots of band edge.

802.11b mode

802.11b, Chain J0 Low Band Edge

802.11b, Chain J1 Low Band Edge

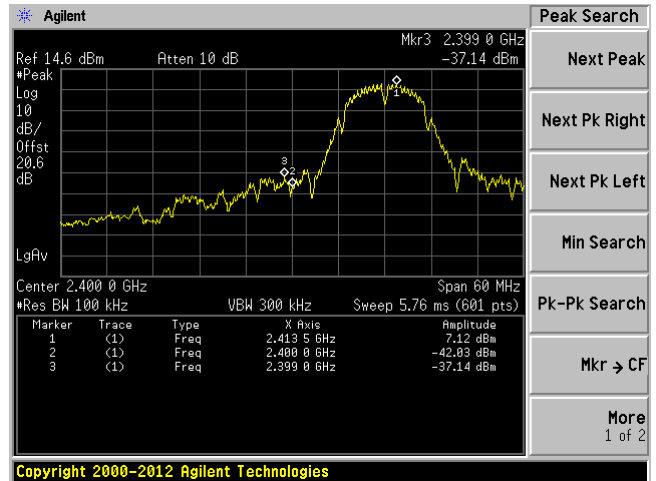
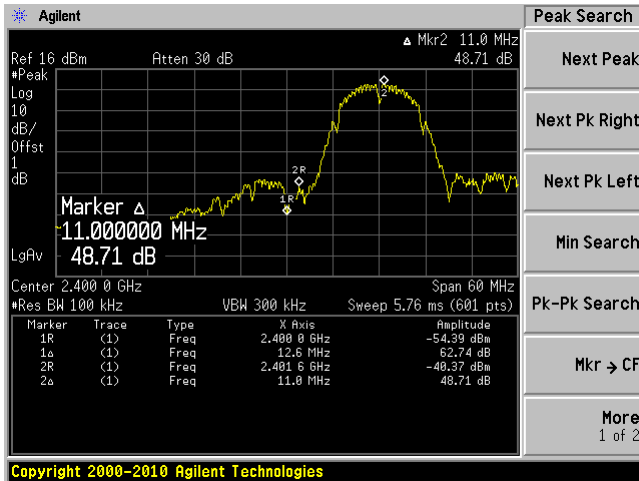

802.11b, Chain J0 High Band Edge

802.11b, Chain J1 High Band Edge

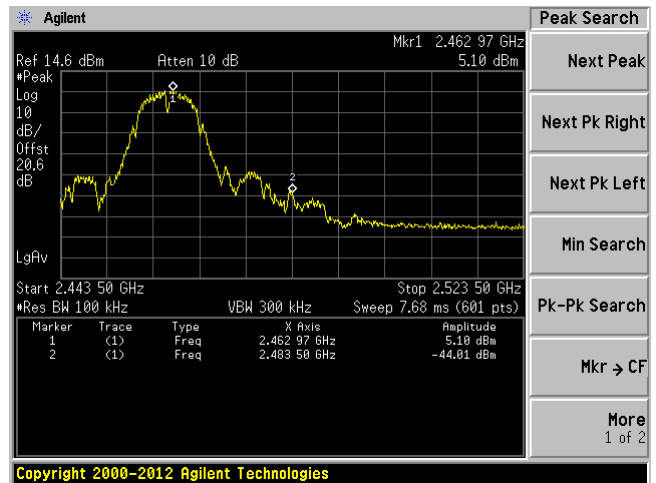
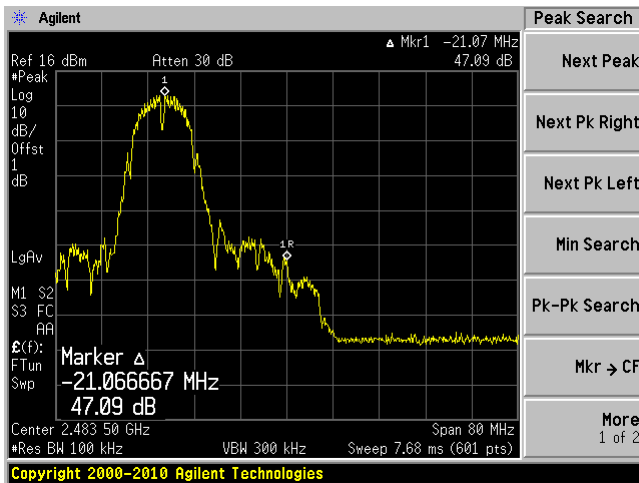

802.11g mode

802.11g, Chain J0 Low Band Edge

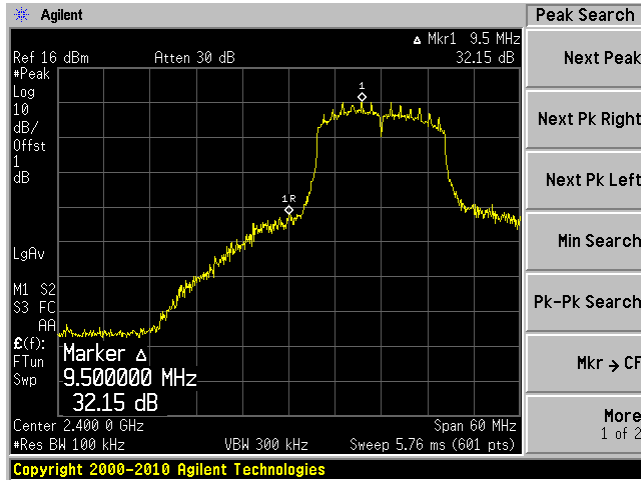

802.11g, Chain J1 Low Band Edge

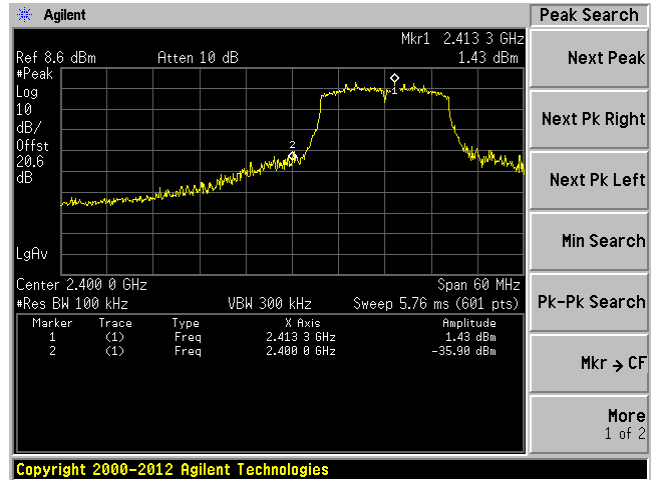

802.11g, Chain J0 High Band Edge

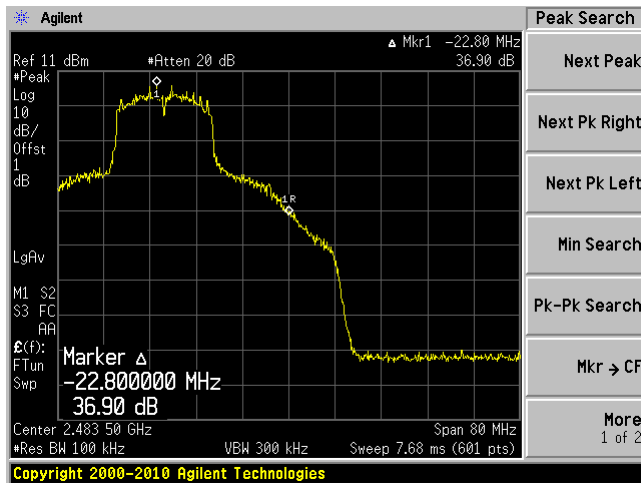

802.11g, Chain J1 High Band Edge

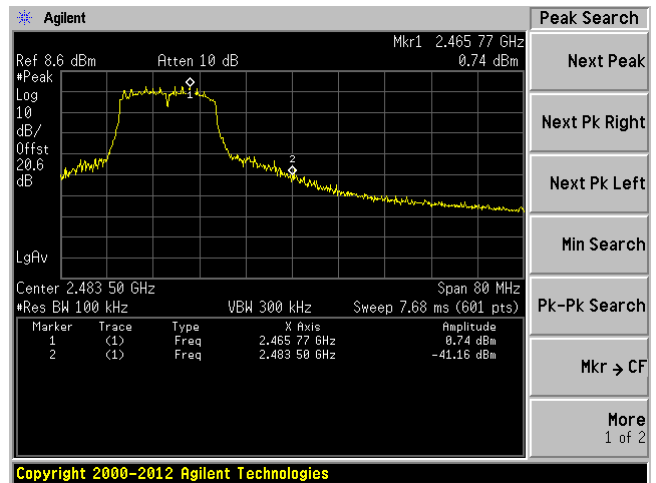

802.11n-HT20 mode

802.11n-HT20, Chain J0 Low Band Edge

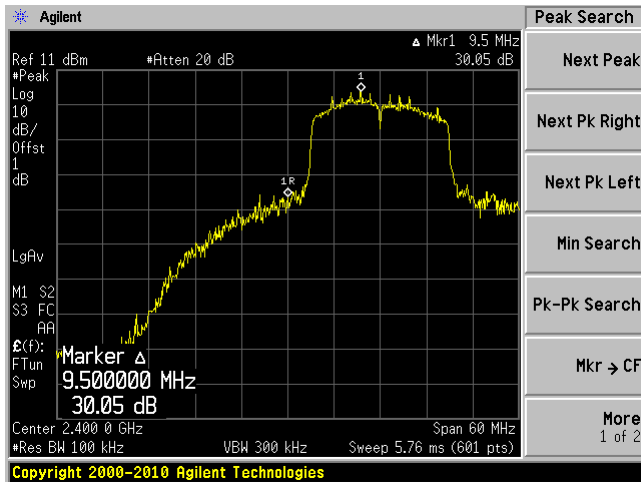

802.11n-HT20, Chain J1 Low Band Edge

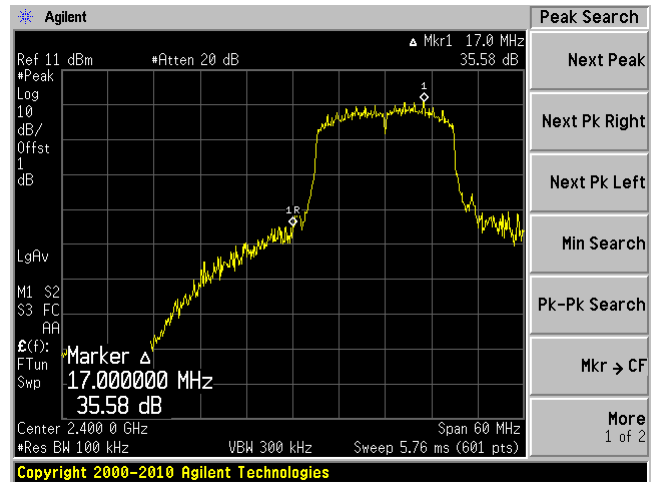

802.11n-HT20, Chain J0 High Band Edge

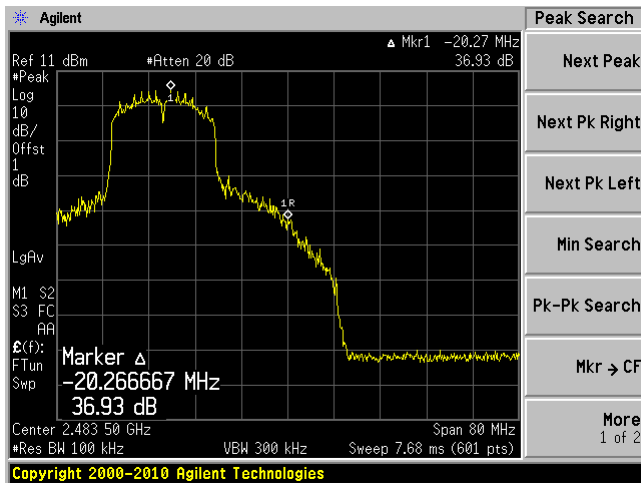

802.11n-HT20, Chain J1 High Band Edge

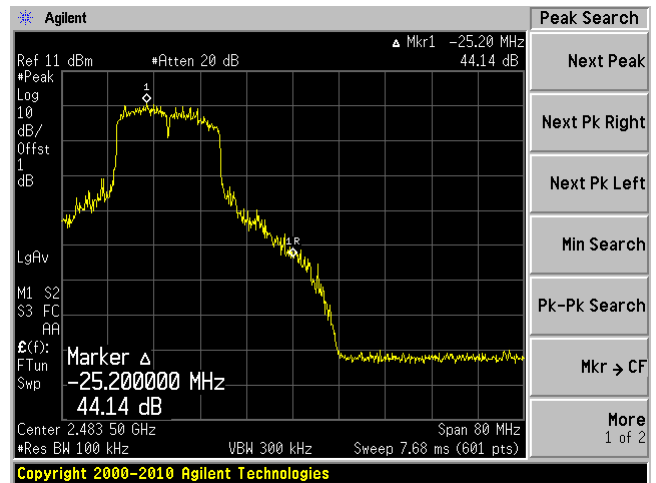



802.11n-HT40 mode

802.11n-HT40, Chain J0 Low Band Edge

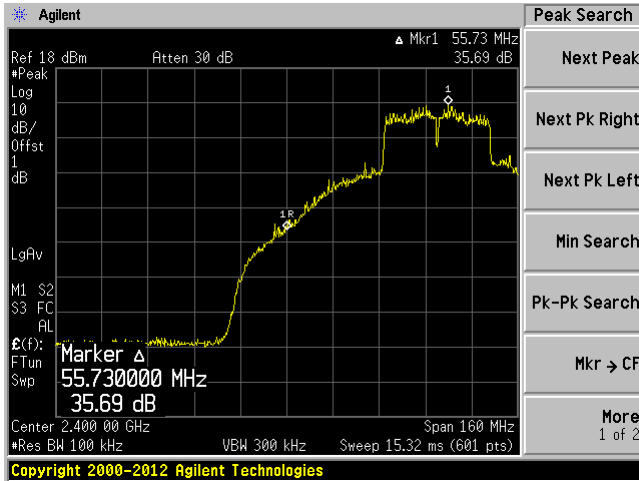

802.11n-HT40, Chain J1 Low Band Edge

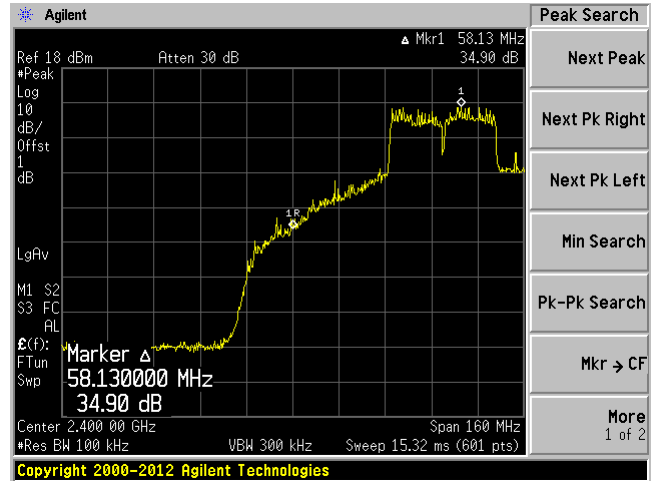

802.11n-HT40, Chain J0 High Band Edge

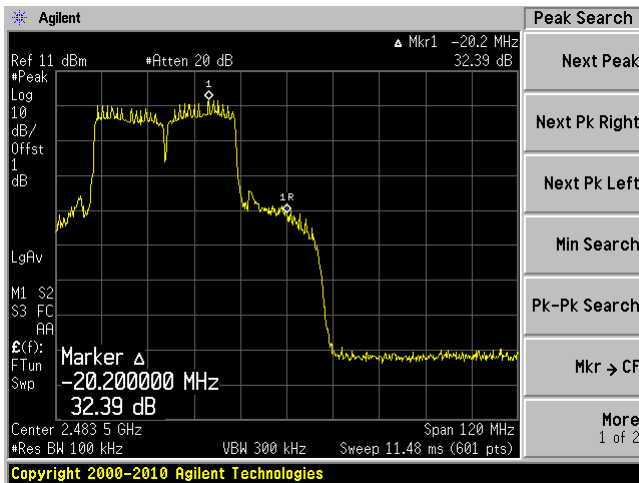

802.11n-HT40, Chain J1 High Band Edge

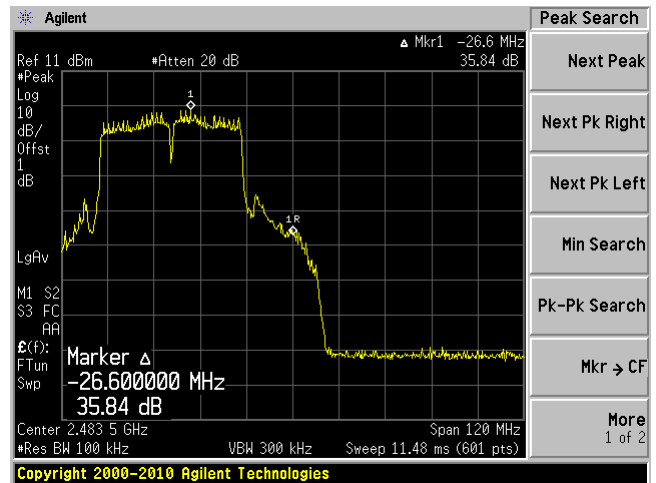

## 12 FCC §15.247(e) & IC RSS-210 §A8.2 (b) – Power Spectral Density

### 12.1 Applicable Standard

According to FCC §15.247(e) and RSS-210 §A8.2 (b), for digitally modulated systems, the power spectral density conducted from the intentional radiator to the antenna shall not be greater than 8 dBm in any 3 kHz band during any time interval of continuous transmission.

### 12.2 Measurement Procedure

The measurements are base on FCC KDB 558074 D01 DTS Meas Guidance v03r01: Guidance for Performing Compliance Measurements on Digital Transmission Systems (DTS) Operating Under §15.247 section 10: Maximum power spectral density level in the fundamental emission

### 12.3 Test Equipment List and Details

Manufacturer	Description	Model No.	Serial No.	Calibration Date	Calibration Interval
Agilent	Spectrum Analyzer	E4440A	MY44303352	2013-11-07	1 year

*Statement of Traceability: BACL Corp. attests that all calibrations have been performed per the A2LA requirements, traceable to the NIST.*

### 12.4 Test Environmental Conditions

<b>Temperature:</b>	22-24 °C
<b>Relative Humidity:</b>	42-45 %
<b>ATM Pressure:</b>	101-102 kPa

*The testing was performed by Rui Zhou from 2014-10-03 and 2014-10-06 at RF site.*

**12.5 Test Results**

Channel	Frequency (MHz)	PSD (dBm)		Max PSD (dBm)	Limit (dBm)	Result
		Chain J0	Chain J1			
802.11b mode						
Low	2412	-5.56	-7.11	-5.56	8	Pass
Middle	2437	-4.93	-6.57	-4.93	8	Pass
High	2462	-7.85	-9.16	-7.85	8	Pass
802.11g mode						
Low	2412	-7.75	-13.54	-7.75	8	Pass
Middle	2437	-6.61	-12.12	-6.61	8	Pass
High	2462	-10.42	-14.84	-10.42	8	Pass

Channel	Frequency (MHz)	PSD (dBm)		Total PSD (dBm)	Limit (dBm)	Result
		Chain J0	Chain J1			
802.11n-HT20 mode						
Low	2412	-9.58	-12.45	-7.77	8	Pass
Middle	2437	-8.35	-12.13	-6.83	8	Pass
High	2462	-11.2	-11.35	-8.26	8	Pass
802.11n-HT40 mode						
Low	2422	-11.4	-15.49	-9.97	8	Pass
Middle	2437	-11.88	-14.17	-9.87	8	Pass
High	2452	-14.37	-17.7	-12.71	8	Pass

Please refer to the following plots for detailed test results:

802.11b mode

Low channel J0: 2412 MHz

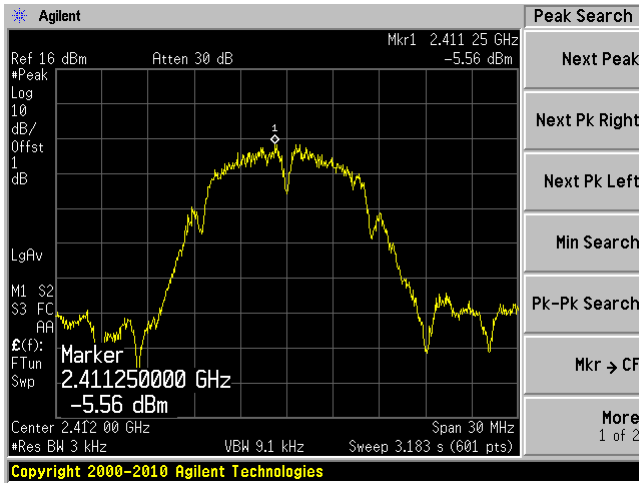

Low channel J1: 2412 MHz

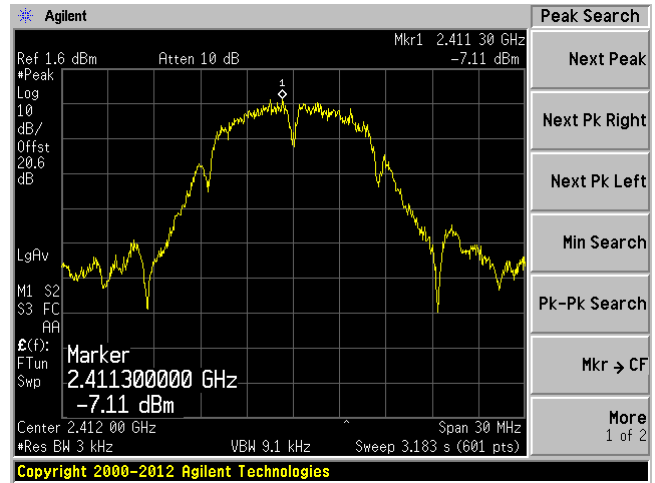

Middle channel J0: 2437 MHz

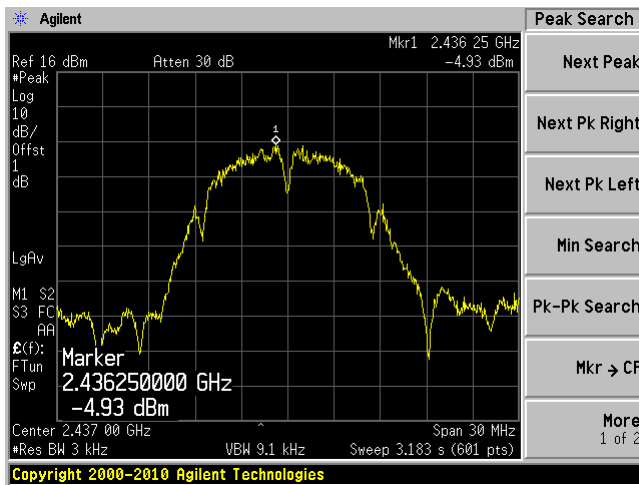

Middle channel J1: 2437 MHz

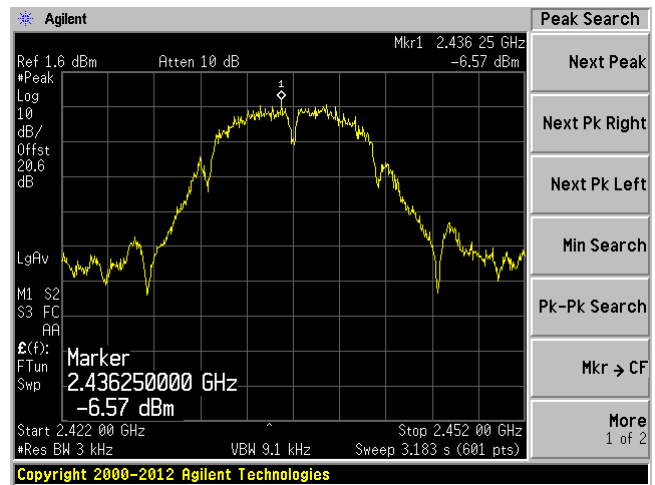

High channel J0: 2462 MHz

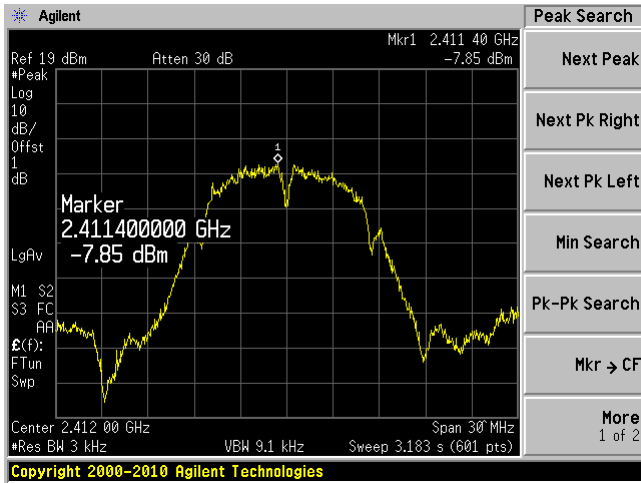

High channel J1: 2462 MHz

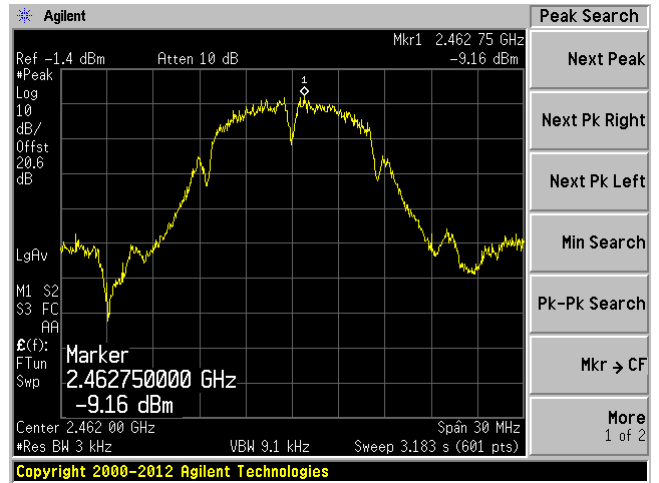

802.11g mode

Low channel J0: 2412 MHz

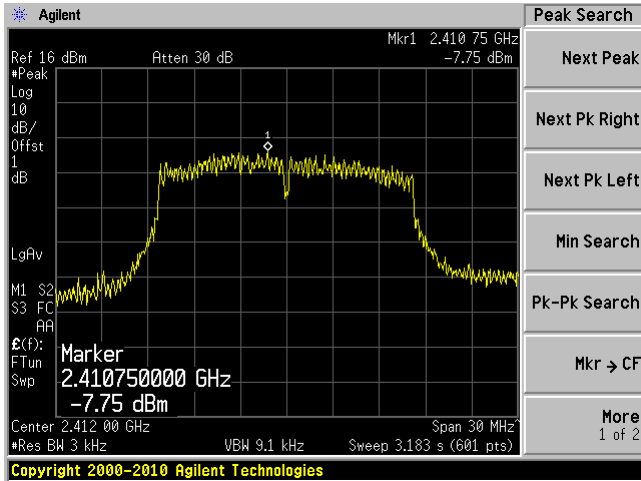

Low channel J1: 2412 MHz

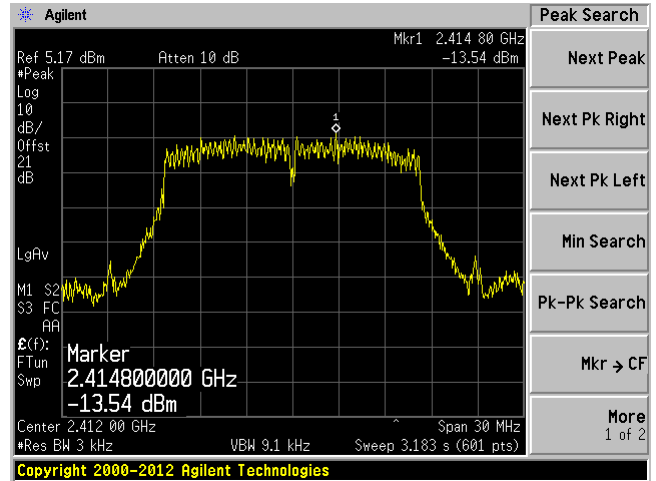

Middle channel J0: 2437 MHz

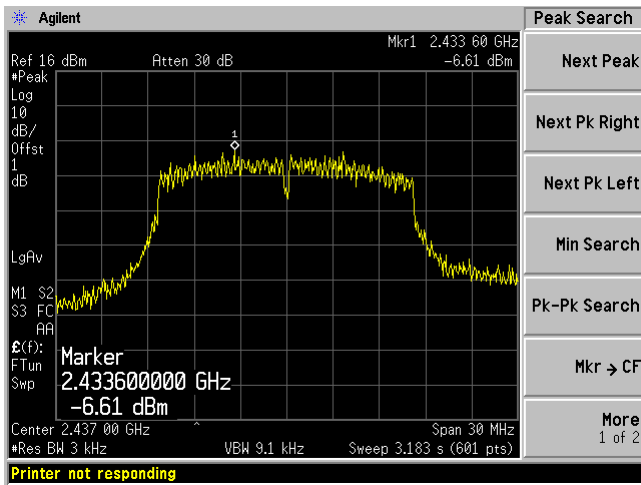

Middle channel J1: 2437 MHz

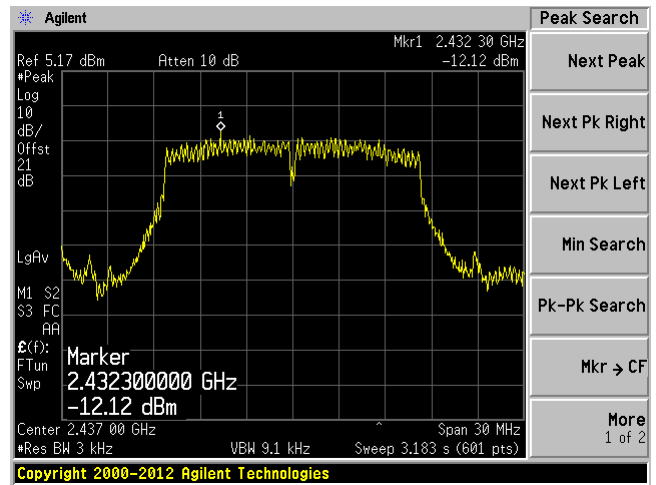

High channel J0: 2462 MHz

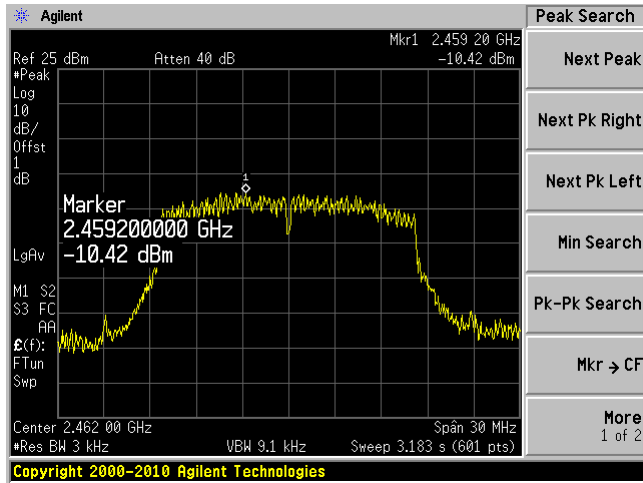

High channel J1: 2462 MHz

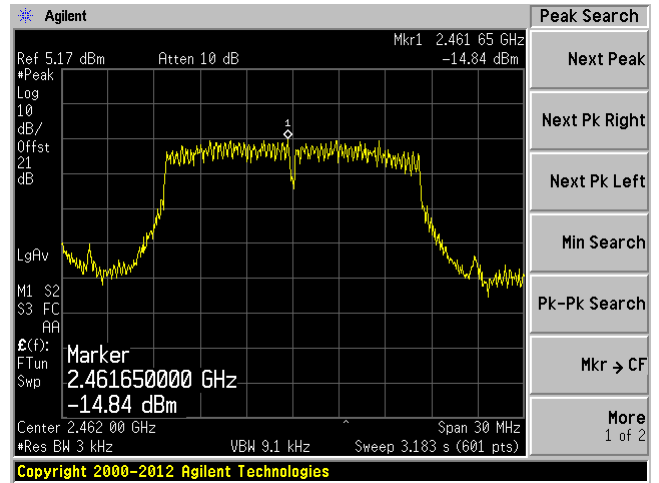

802.11n-HT20 mode

Low channel J0: 2412 MHz

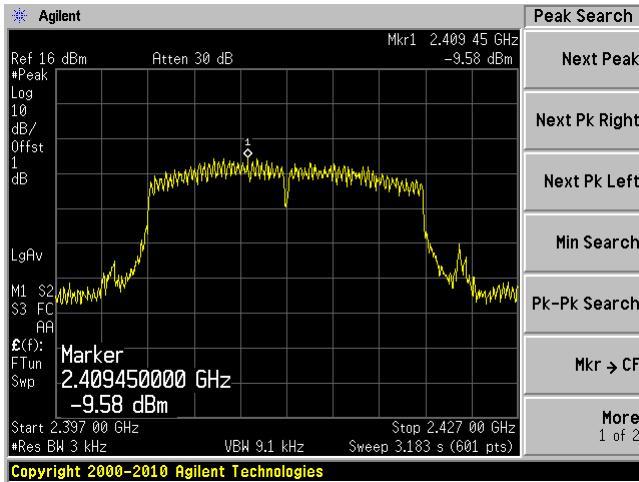

Low channel J1: 2412 MHz

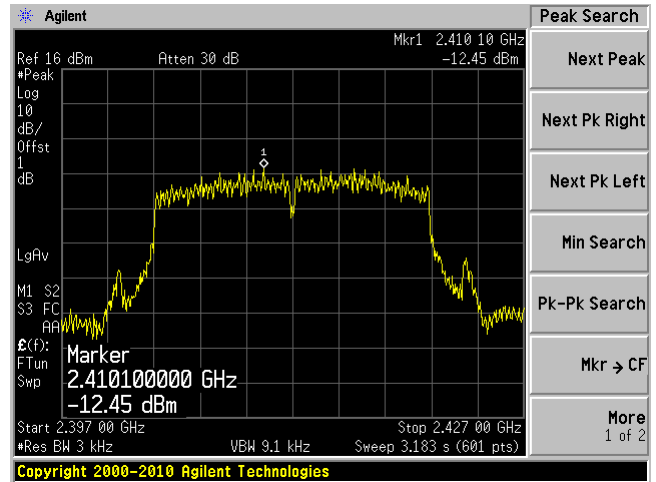

Middle channel J0: 2437 MHz

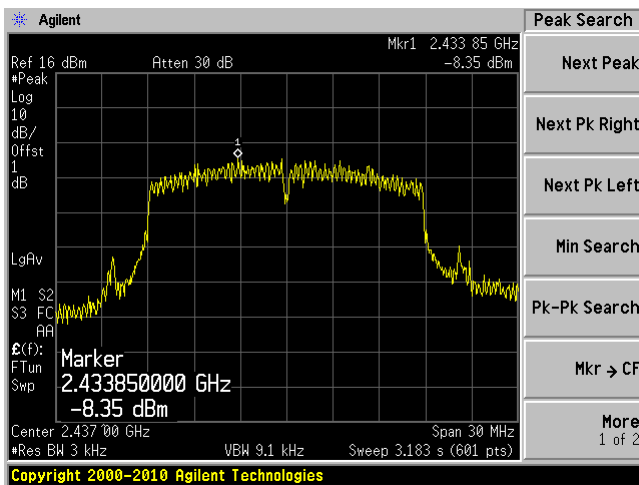

Middle channel J1: 2437 MHz

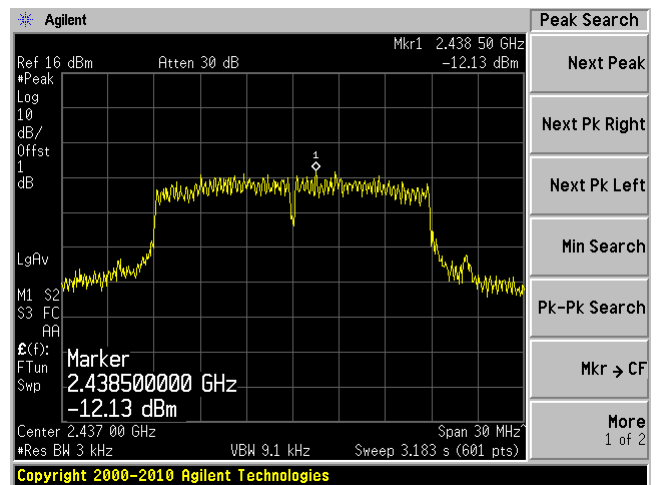



### High channel J0: 2462 MHz

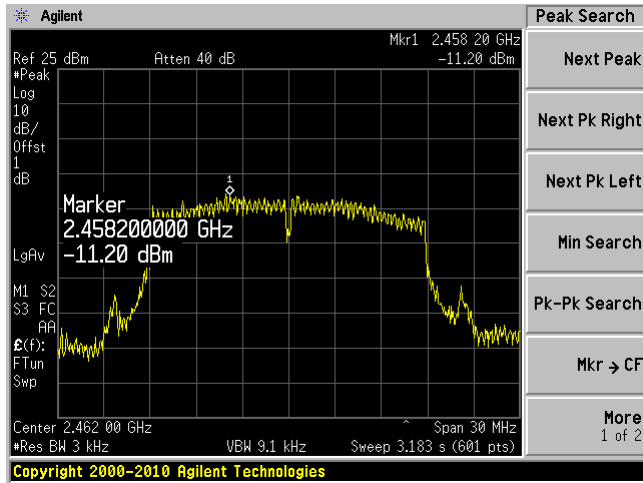

### High channel J1: 2462 MHz

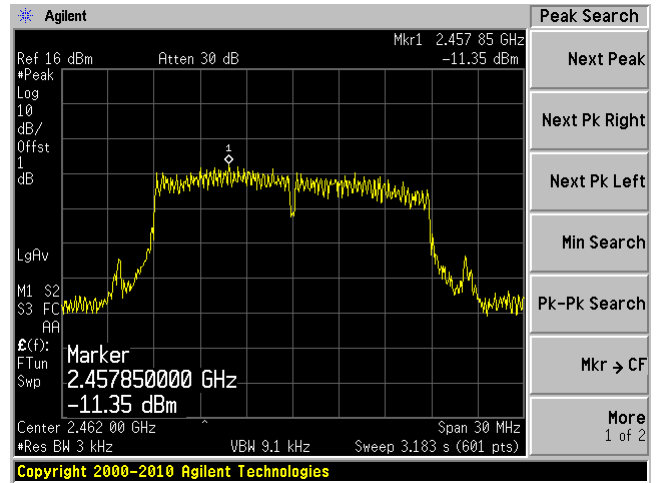

802.11n-HT40 mode

Low channel J0: 2422 MHz

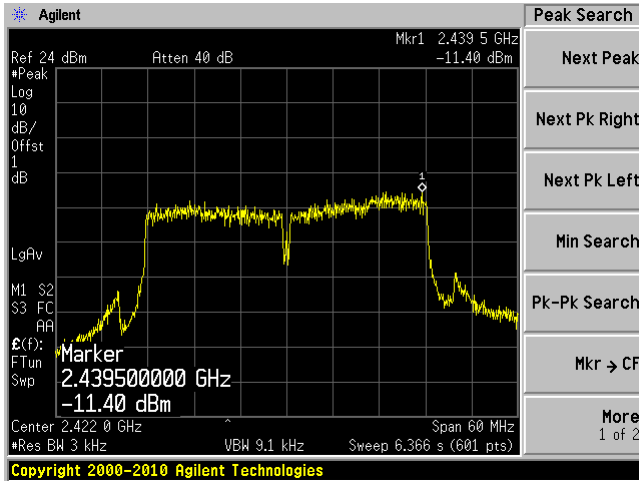

Low channel J1: 2422 MHz

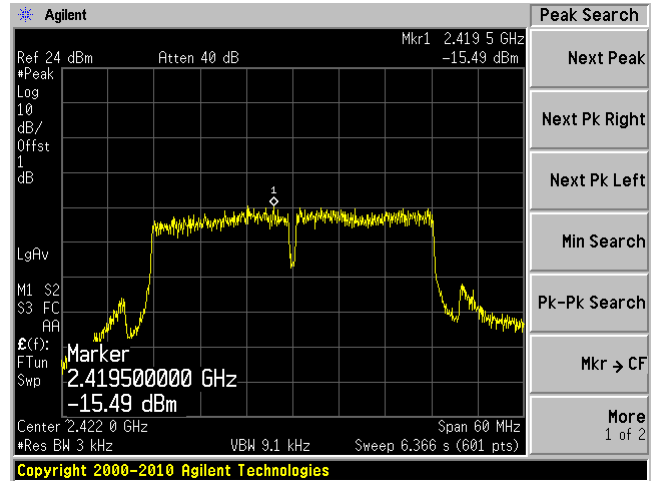

Middle channel J0: 2437 MHz

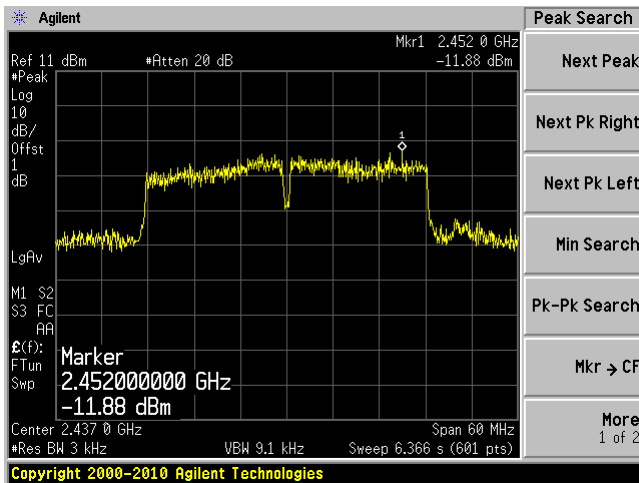

Middle channel J1: 2437 MHz

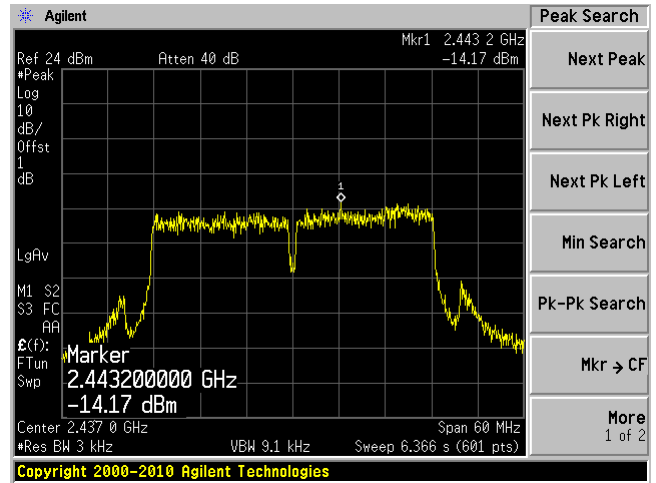

High channel J0: 2452 MHz

High channel J1: 2452 MHz

