

FCC Part 15

TEST REPORT

For

Bluetooth Headset (Class 2)

Model Name: Q9

Brand Name: Bluedio

FCC ID: VO8-Q9

Report No.: AGC10430911GZ03-5E6

Date of Issue: Dec.03, 2009

Prepared For

Guangzhou Liwei Electronics Co., LTD.

No.33, Zhenzhongbei Road, Shenshan Industrial Park Baiyun District,

Guangzhou 510460 P.R., china

TEL: 020-8606 2626 826

FAX: 020-8606 2626 800

Prepared By

Attestation of Global Compliance Co., Ltd.

2F., No.2 Building, Huafeng No.1 Technical Industrial Park, Sanwei,

Xixiang, Baoan District, Shenzhen

TEL: 86-755-2908 1966

FAX: 86-755-2600 8484

VERIFICATION OF COMPLIANCE

Applicant:	Guangzhou Liwei Electronics Co., LTD.
Address	No.33, Zhenzhongbei Road, Shenshan Industrial Park Baiyun District, Guangzhou 510460 P.R., china
Product Description:	Bluetooth Headset (Class 2)
Brand Name:	Bluedio
Model Number:	Q9
FCC ID	VO8-Q9
Report Number:	AGC10430911GZ03-5E6
Date of Test:	Nov.29, 2009-Dec.03, 2009

WE HEREBY CERTIFY THAT:

The above equipment was tested by Shenzhen Attestation of Global Compliance Science & Technology Co., Ltd. The test data, data evaluation, test procedures, and equipment configurations shown in this report were made in accordance with the procedures given in ANSI C63.4 (2003) and the energy emitted by the sample EUT tested as described in this report is in compliance with radiated emission limits of FCC Rules Part 15.247.

Checked By: Jekey Zhang
Jekey Zhang Dec.03, 2009

Authorized By King Zhang
King Zhang Dec.03, 2009

TABLE OF CONTENTS

1.GENERAL INFORMATION	4
1.1 PRODUCT DESCRIPTION.....	4
1.2 RELATED SUBMITTAL(S) / GRANT (S)	4
1.3 TEST METHODOLOGY	4
1.4 TEST FACILITY.....	4
1.5 SPECIAL ACCESSORIES	4
1.6 EQUIPMENT MODIFICATIONS	4
2. SYSTEM TEST CONFIGURATION	5
2.1 CONFIGURATION OF TESTED SYSTEM	5
2.2 EQUIPMENT USED IN TESTED SYSTEM	5
3. SUMMARY OF TEST RESULTS	6
4. DESCRIPTION OF TEST MODES	6
5. CONDUCTION EMISSIONS	7
5.1 MEASUREMENT PROCEDURE:	7
5.2 TEST SET-UP (BLOCK DIAGRAM OF CONFIGURATION)	7
5.3 MEASUREMENT EQUIPMENT USED:	7
5.4 LIMITS AND MEASUREMENT RESULT:	8
5.5 TEST RESULT OF LINE CONDUCTED EMISSION TEST	9
6. MAXIMUM OUTPUT POWER	11
6.1 MEASUREMENT PROCEDURE:	11
6.2 TEST SET-UP (BLOCK DIAGRAM OF CONFIGURATION)	11
6.3 MEASUREMENT EQUIPMENT USED:	14
6.4 LIMITS AND MEASUREMENT RESULT:	15
7. 20 DB BANDWIDTH	17
7.1 MEASUREMENT PROCEDURE	17
7.2 TEST SET-UP (BLOCK DIAGRAM OF CONFIGURATION)	17
7.3 MEASUREMENT EQUIPMENT USED:	17
7.4 LIMITS AND MEASUREMENT RESULTS:.....	17
8. MAXIMUM CONDUCTED OUTPUT POWER SPECTRAL DENSITY(N/A)	19
8.1 MEASUREMENT PROCEDURE:	19
8.2 TEST SET-UP (BLOCK DIAGRAM OF CONFIGURATION)	19
8.3 MEASUREMENT EQUIPMENT USED:	19
8.4 LIMITS AND MEASUREMENT RESULT:	19
9. OUT OF BAND EMISSION	20

9.1 MEASUREMENT PROCEDURE:20

9.2 TEST SET-UP (BLOCK DIAGRAM OF CONFIGURATION) 20

9.3 MEASUREMENT EQUIPMENT USED:20

9.4 LIMITS AND MEASUREMENT RESULT:.....20

10. NUMBER OF HOPPING FREQUENCY29

10.1 MEASUREMENT PROCEDURE29

10.2 TEST SETUP (BLOCK DIAGRAM OF CONFIGURATION)29

10.3 MEASUREMENT EQUIPMENT USED29

10.4 LIMITS AND MEASUREMENT RESULT:.....29

11.TIME OF OCCUPANCY (DWELL TIME).....31

11.1 MEASUREMENT PROCEDURE31

11.2 TEST SETUP (BLOCK DIAGRAM OF CONFIGURATION)31

11.3 MEASUREMENT EQUIPMENT USED31

11.4 LIMITS AND MEASUREMENT RESULT31

12.FREQUENCY SEPARATION32

12.1 MEASUREMENT PROCEDURE37

12.2 TEST SETUP (BLOCK DIAGRAM OF CONFIGURATION)37

12.3 MEASUREMENT EQUIPMENT USED37

12.4 LIMITS AND MEASUREMENT RESULT37

APPENDIX I38

PHOTOGRAPHS OF THE EUT38

PPENDIX II.....41

PHOTOGRAPHS OF THE TEST SETUP41

GENERAL INFORMATION

1.1 PRODUCT DESCRIPTION

The EUT is a short range, lower power; **Bluetooth Headset (Class 2)** designed as an “Communication Device”. It is designed by way of utilizing the FHSS technology to achieve the system operation.

A major technical description of EUT is described as following:

Operation Frequency	2.402 GHz to 2.480GHz
Rated Output Power	2.43 dBm
Modulation	GFSK
Number of channels	79
Antenna Designation	Integrated Antenna
Power Supply	Internal Lion Composite Battery DC 3.6~4.2V
Travel Adapter	Output :DC5.1-5.6V

1.2 RELATED SUBMITTAL(S) / GRANT (S)

This submittal(s) (test report) is intended for **FCC ID:VO8-Q9** filing to comply with Section 15.247 of the FCC Part 15, Subpart C Rules.

1.3 TEST METHODOLOGY

Both conducted and radiated testing were performed according to the procedures in ANSI C63.4 (2003). Radiated testing was performed at an antenna to EUT distance 3 meters.

1.4 TEST FACILITY

All measurement facilities used to collect the measurement data are located at
Word Standardization Certification & Testing Co., Ltd.

1-2/F, Dachong Keji Building, No.28 of Tonggu Road, Nanshan District, Shenzhen, 518057, China

The test site is constructed and calibrated to meet the FCC requirements in documents ANSI C63.4: 2003.
FCC register No.: 276008

Radiated emissions are measured with one or more of the following types of linearly polarized antennas: tuned dipole, biconical, log periodic, bi-log, and/or ridged waveguide, horn. Spectrum analyzers with preselectors and quasi-peak detectors are used to perform radiated measurements.

1.5 SPECIAL ACCESSORIES

Not available for this EUT intended for grant.

1.6 EQUIPMENT MODIFICATIONS

Not available for this EUT intended for grant.

1. SYSTEM TEST CONFIGURATION

2.1 CONFIGURATION OF TESTED SYSTEM

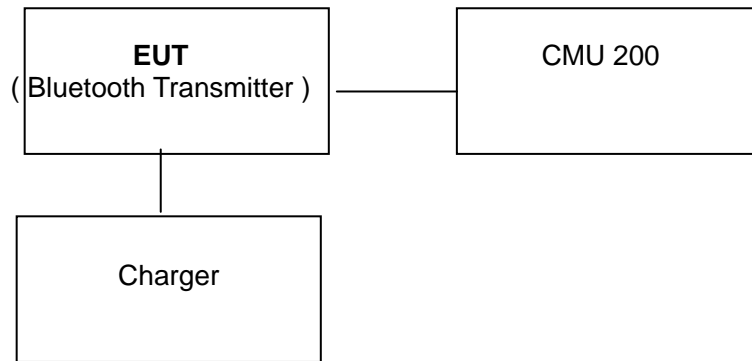

2.2 EQUIPMENT USED IN TESTED SYSTEM

Item	Equipment	Mfr/Brand	Model/Type No.	FCC ID
1	Bluetooth Headset (Class 2)	Bluedio	Q9	VO8-Q9
2	CMU	R&S	CMU200	--
3	Charger	--	--	--

3. SUMMARY OF TEST RESULTS

FCC RULES	DESCRIPTION OF TEST	RESULT
§15.207	Conduction Emission	Compliant
§15.209	Radiated Emission	Compliant
§15.247	Maximum Output Power	Compliant
§15.247	20 dB Bandwidth	Compliant
§15.247	Band Edges	Compliant
§15.247	Spurious Emission	Compliant
§15.247	Frequency Separation	Compliant
§15.247	Number of Hopping Frequency	Compliant
§15.247	Time of Occupancy	Compliant

4. DESCRIPTION OF TEST MODES

1. The EUT has been set to operate continuously on the lowest, the middle and the highest operation frequency individually.
2. The EUT stays in continuous transmitting mode on the operation frequency being set.

5. CONDUCTION EMISSIONS

5.1 MEASUREMENT PROCEDURE:

1. The equipment was set up as per the test configuration to simulate typical actual usage per the user's manual. The EUT is a tabletop system; a wooden table with a height of 0.8 meters is used and is placed on the ground plane as per ANSI C63.4.
2. Support equipment, if needed, was placed as per ANSI C63.4.
3. All I/O cables were positioned to simulate typical actual usage as per ANSI C63.4.
4. The EUT received DC4.2V through a Line Impedance Stabilization Network (LISN) which supplied power source and was grounded to the ground plane.
5. All support equipments received AC power from a second LISN, if any.
6. The EUT test program was started. Emissions were measured on each current carrying line of the EUT using a spectrum Analyzer / Receiver connected to the LISN powering the EUT. The LISN has two monitoring points: Line 1 (Hot Side) and Line 2 (Neutral Side). Two scans were taken: one with Line 1 connected to Analyzer / Receiver and Line 2 connected to a 50 ohm load; the second scan had Line 1 connected to a 50 ohm load and Line 2 connected to the Analyzer / Receiver.
7. Analyzer / Receiver scanned from 150 KHz to 30MHz for emissions in each of the test modes.
8. During the above scans, the emissions were maximized by cable manipulation.

5.2 TEST SET-UP (BLOCK DIAGRAM OF CONFIGURATION)

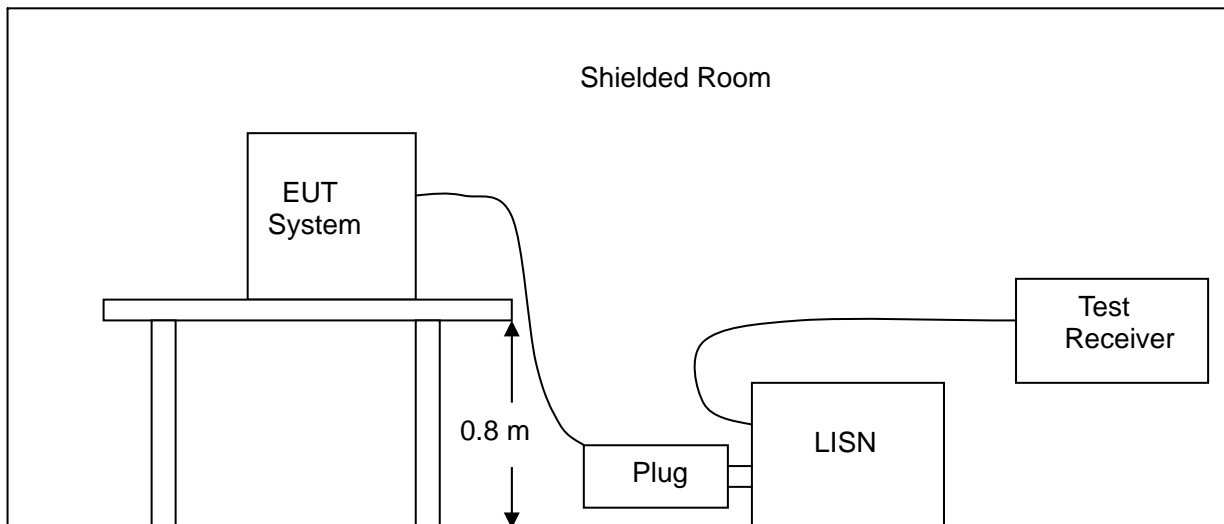

5.3 MEASUREMENT EQUIPMENT USED:

Conducted Emission Test Site				
Name of Equipment	Manufacturer	Model	Serial Number	Cal. Date
Test Receiver	Rohde & Schwarz	ESCS30	828985/018	05/29/2010
LISN	Rohde & Schwarz	ESH2-Z5	834549/005	05/29/2010
LISN	Rohde & Schwarz	ESH2-Z5	834549/005	05/29/2010
50 Coaxial Switch	Anritsu	MP59B	M20531	05/29/2010

5.4 LIMITS AND MEASUREMENT RESULT:**LIMITS OF LINE CONDUCTED EMISSION TEST**

Frequency	Maximum RF Line Voltage	
	Q.P.(dBuV)	Average(dBuV)
150kHz~500kHz	66-56	56-46
500kHz~5MHz	56	46
5MHz~30MHz	60	50

1**Note: 1. The lower limit shall apply at the transition frequency.

2. The limit decreases linearly with the logarithm of the frequency in the range 0.15 MHz to 0.50 MHz

TEST RESULT OF LINE -L CONDUCTED EMISSION TEST

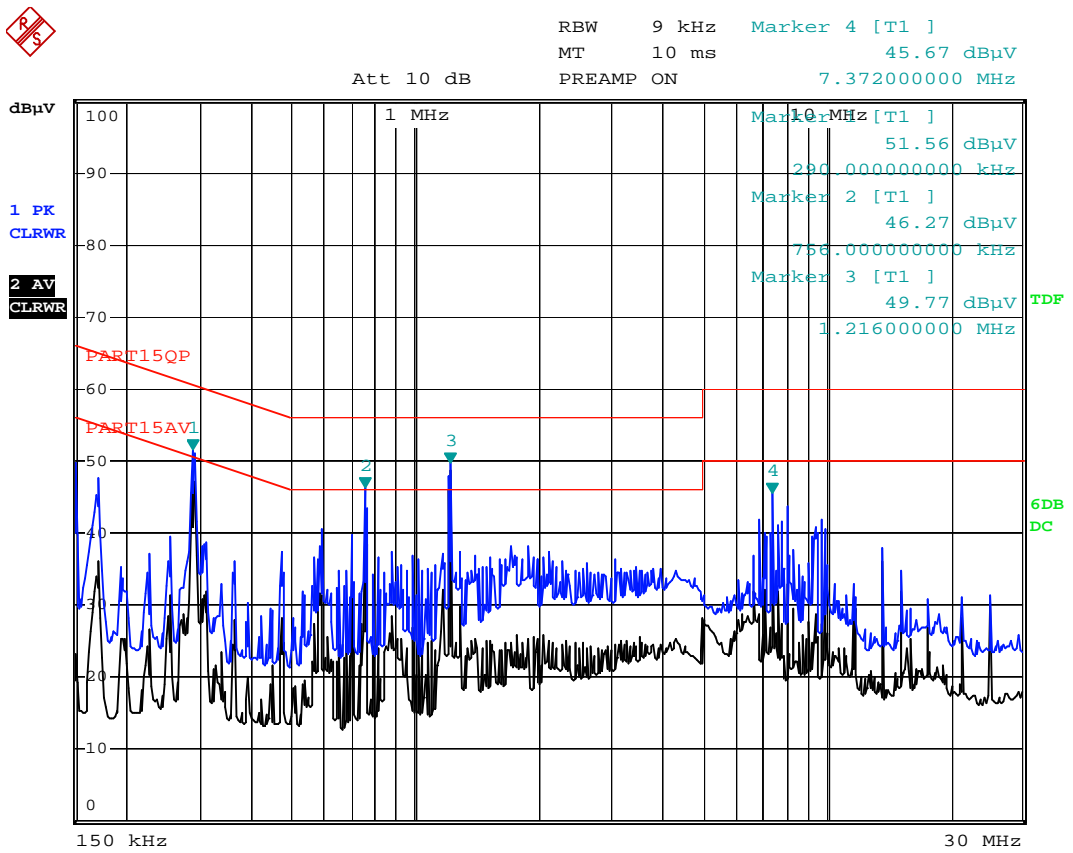

Date: 3.DEC.2009 14:38:02

TEST RESULT OF LINE -N CONDUCTED EMISSION TEST



RBW 9 kHz Marker 4 [T1]
 MT 10 ms 50.28 dBμV
 Att 10 dB PREAMP ON 1.216000000 MHz

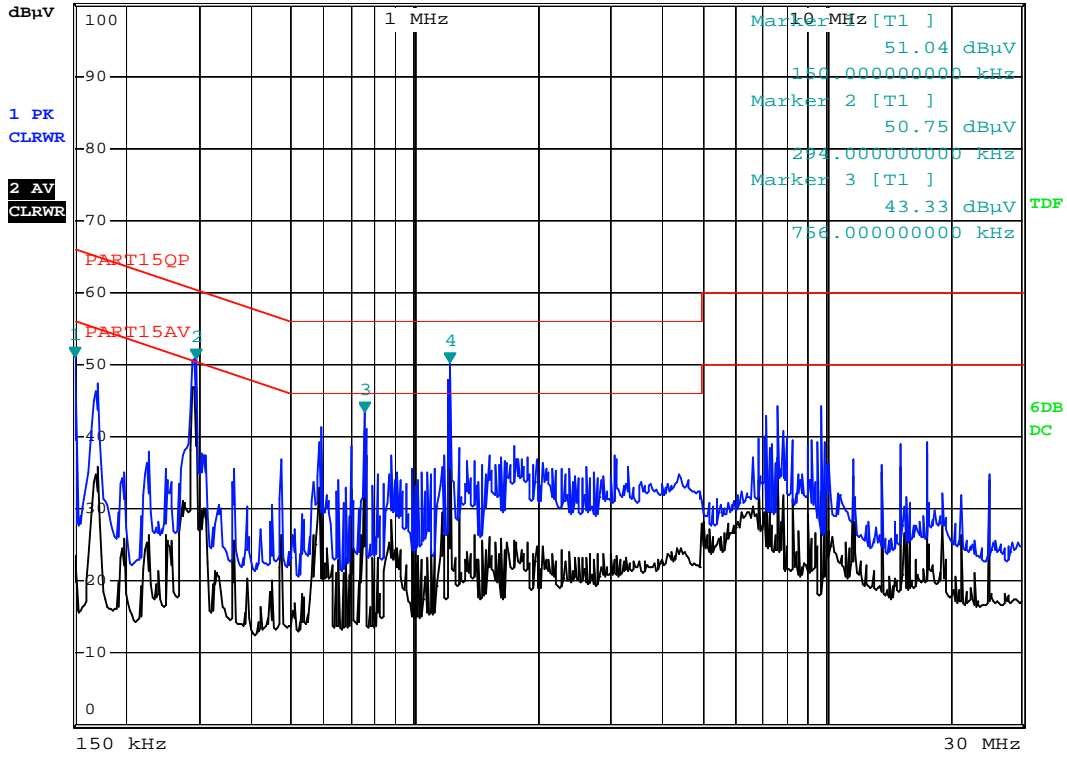

Date: 3.DEC.2009 14:39:14

6. MAXIMUM OUTPUT POWER

6.1 MEASUREMENT PROCEDURE:

CONDUCTED METHOD

1. The EUT was placed on a turn table which is 0.8m above ground plane.
2. Connect EUT RF output port to the Spectrum Analyzer through an RF attenuator
3. Set the EUT Work on the top, the middle and the bottom operation frequency individually.
4. Set SPA Centre Frequency = Operation Frequency, RBW= 1 MHz, VBW= 1 MHz.
5. Set SPA Trace 1 Max hold, then View.

RADIATED METHOD

According to ANSI C63.4:2003

6.2 TEST SET-UP (BLOCK DIAGRAM OF CONFIGURATION)

CONDUCTED METHOD

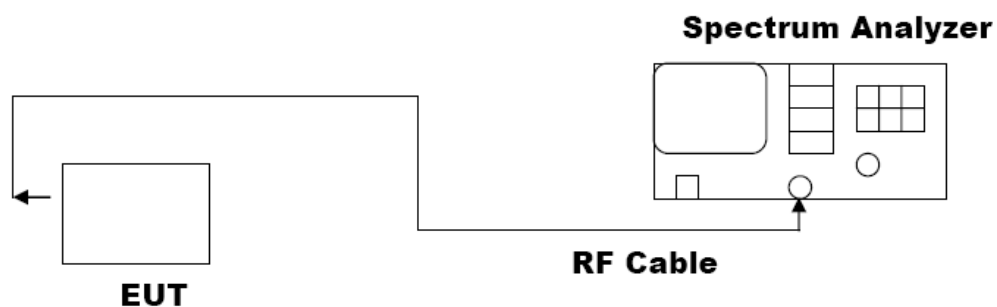

RADIATED EMISSION TEST SETUP

RADIATED MISSION TEST SETUP BELOW 1000MHz

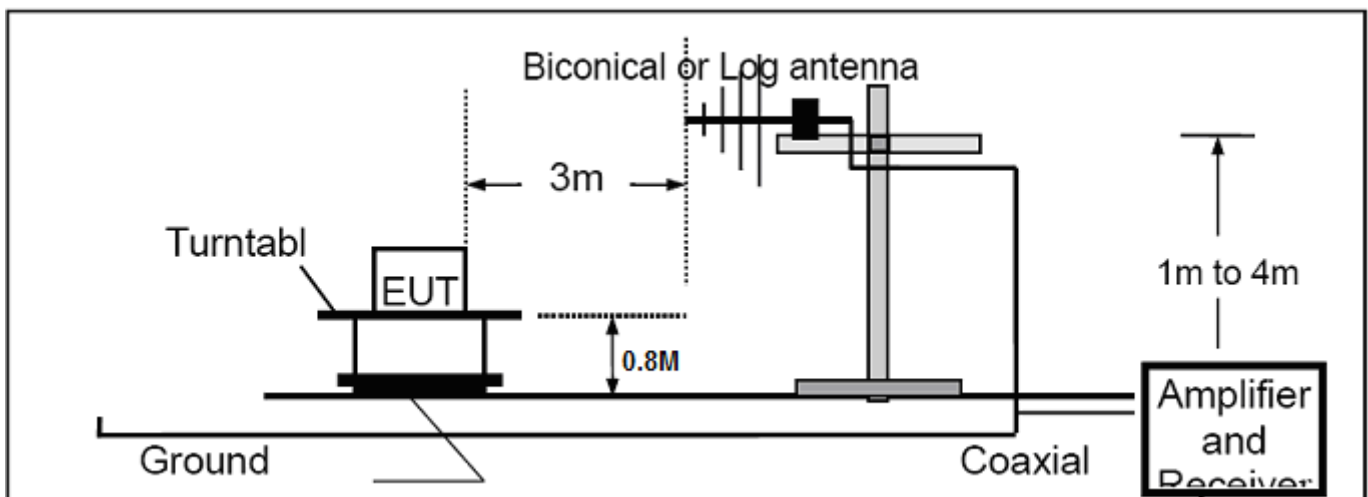

RADIATED EMISSION TEST SETUP ABOVE 1000MHz

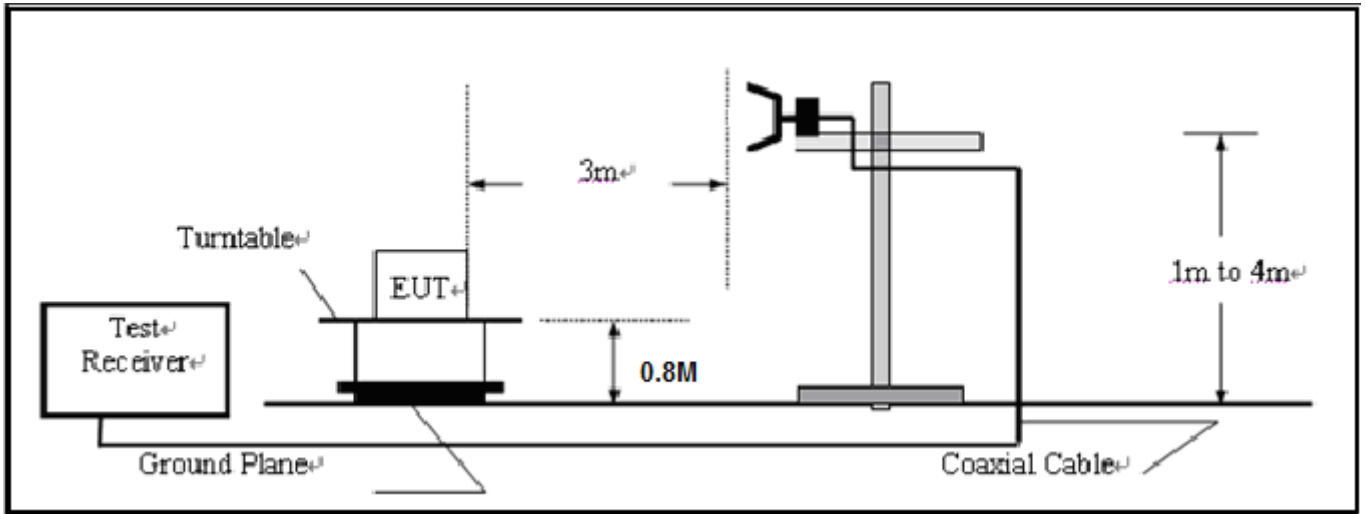

EIRP TEST SETUP

TEST SETUP BELOW 1GHz

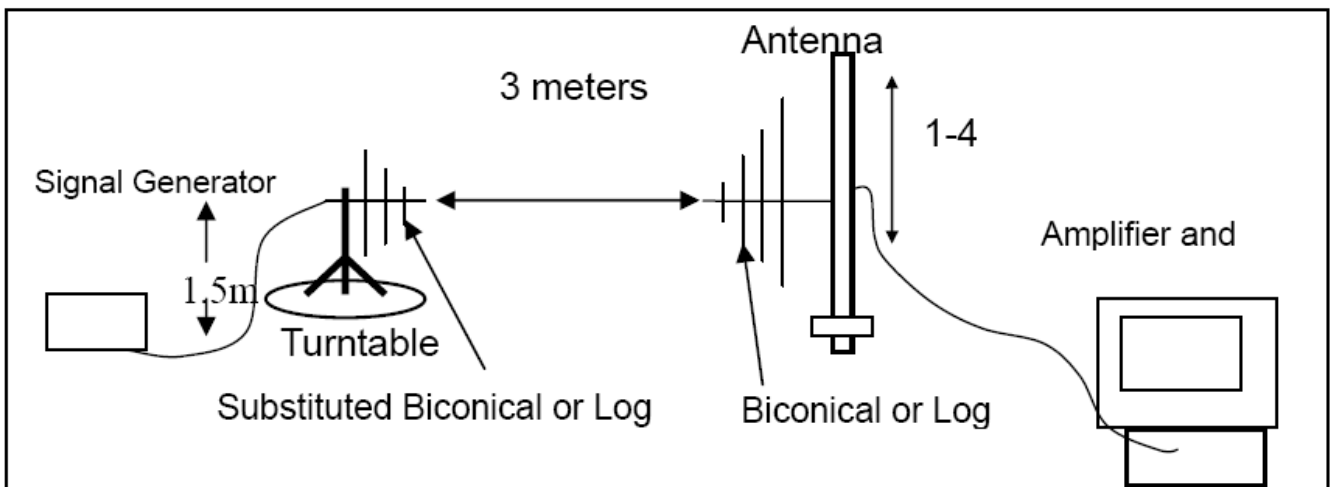
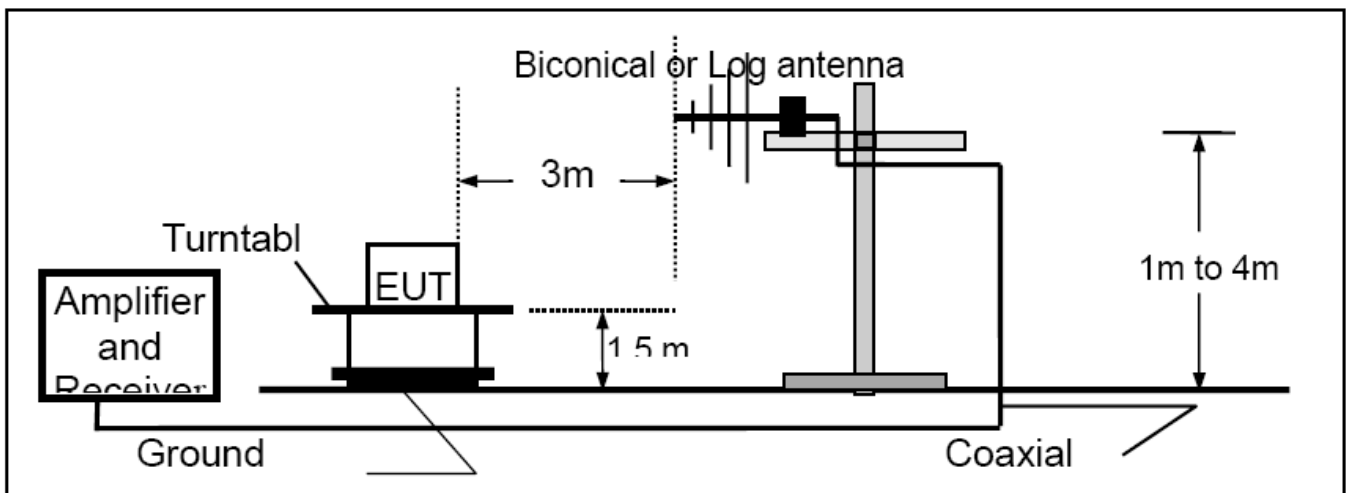

TEST SETUP ABOVE 1GHZ

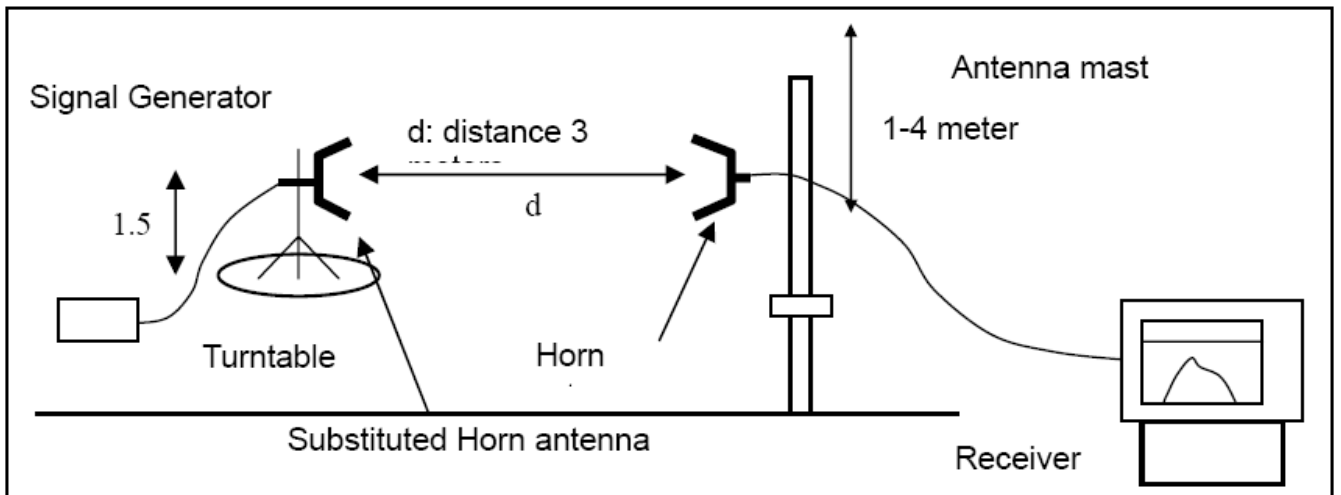
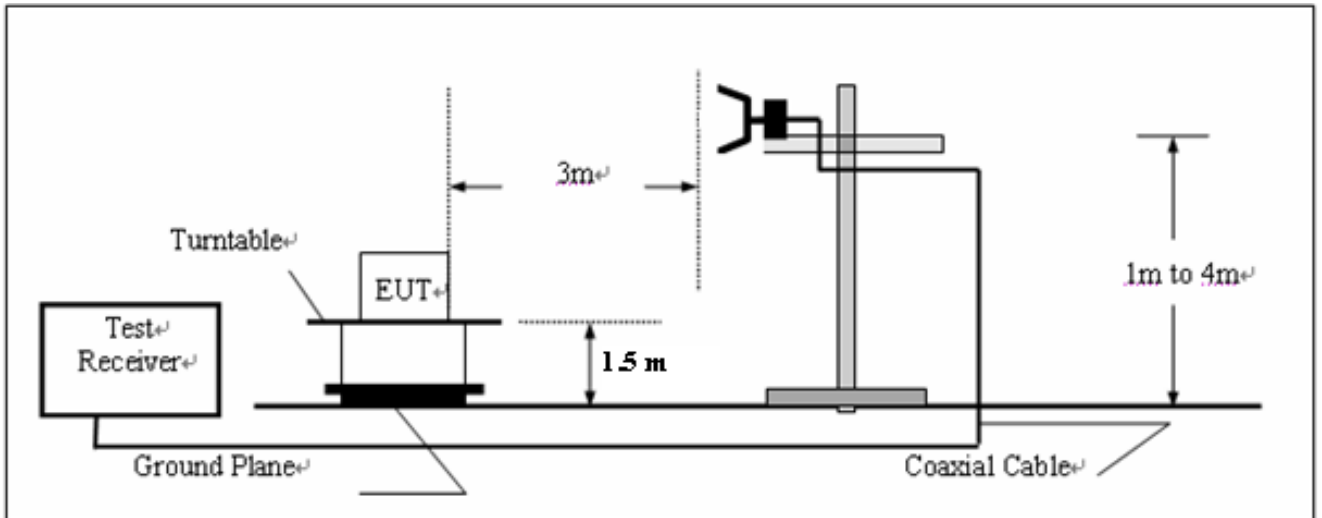

6.3 MEASUREMENT EQUIPMENT USED:

Description	Manufacturer	Model	SERIAL NUMBER	Cal. Date	Cal. Due
Spectrum Analyzer	Rohde & Schwarz	FSEM30	849720/019	05/29/2009	05/29/2010
Amplifier	H.P.	8449B	3008A00277	05/29/2009	05/29/2010
Horn Antenna	Sunol Sciences	DRH-118	A052604	05/29/2009	05/29/2010
EMI Test Receiver	Rohde & Schwarz	ESCI	100028	05/29/2009	05/29/2010
Amplifier	H.P.	HP8447E	1937A01046	05/29/2009	05/29/2010
Broadband Antenna	Sunol Sciences	JB1	A040904-2	05/29/2009	05/29/2010

6.4 LIMITS AND MEASUREMENT RESULT:

LIMITS AND MEASUREMENT RESULT				
Applicable Limits	Frequency	Measurement Result		
		EIRP (dBm)	Conducted (dBm)	Criteria
30 dBm	2.402GHz	2.36	1.82	PASS
30 dBm	2.441GHz	2.43	1.88	PASS
30 dBm	2.480GHz	2.38	1.86	PASS

TEST PLOT OF BOTTOM CHANNEL

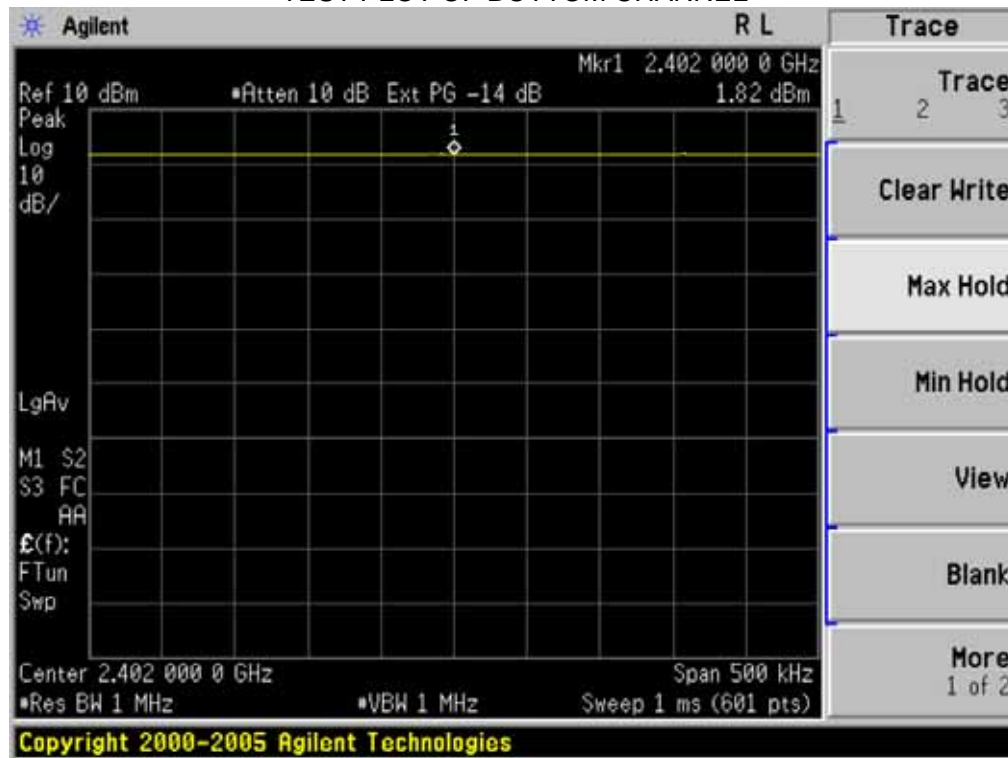

TEST PLOT OF MIDDLE CHANNEL

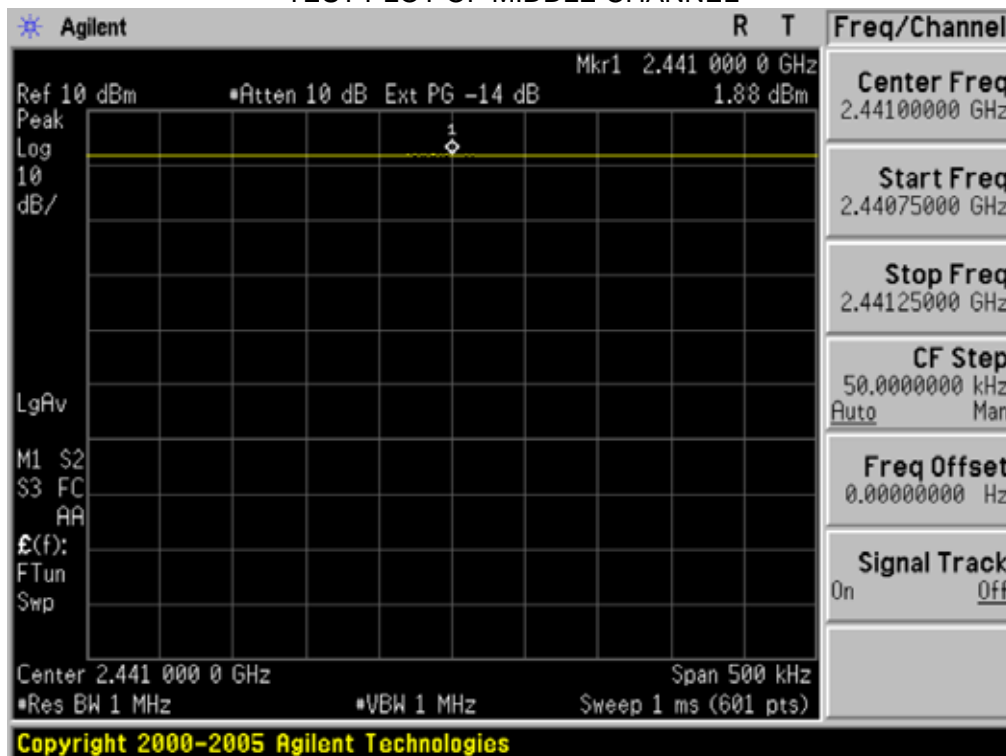

TEST PLOT OF TOP CHANNEL

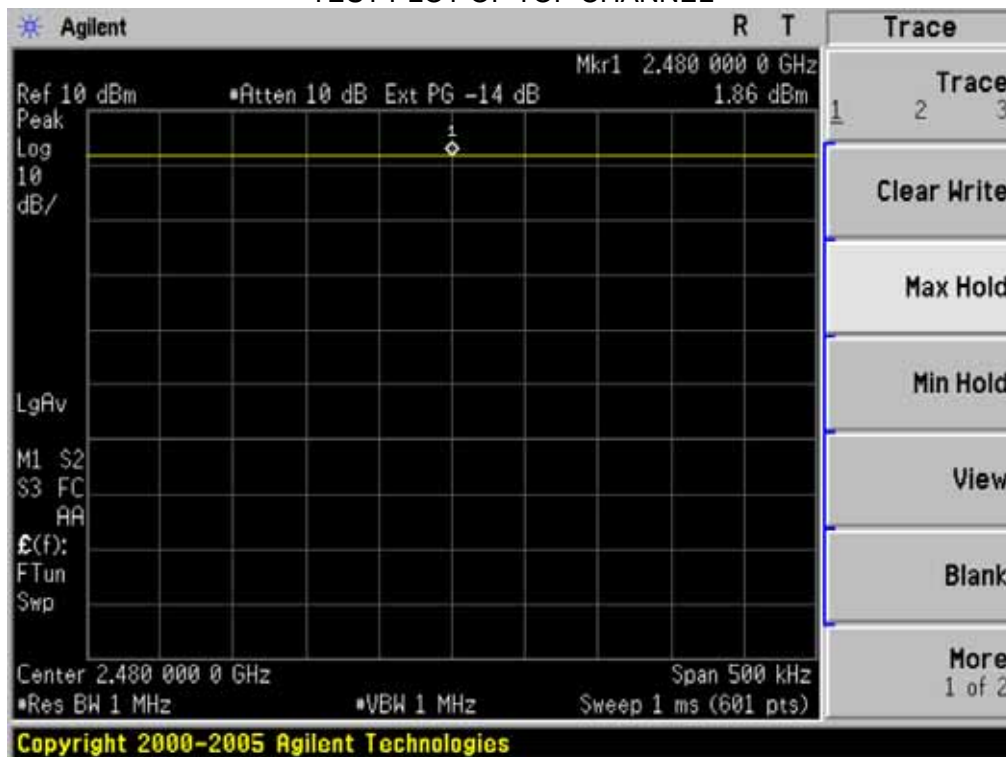

7. 20 DB BANDWIDTH

7.1 MEASUREMENT PROCEDURE

1. The EUT was placed on a turn table which is 0.8m above ground plane.
2. Connect EUT RF output port to the Spectrum Analyzer through an RF attenuator
3. Set the EUT Work on the top, the middle and the bottom operation frequency individually.
3. Set SPA Centre Frequency = Operation Frequency, RBW= 100 KHz, VBW= 100 KHz.
4. Set SPA Trace 1 Max hold, then View.

7.2 TEST SET-UP (BLOCK DIAGRAM OF CONFIGURATION)

The Same as described in Section 6.2

7.3 MEASUREMENT EQUIPMENT USED:

The same as described in Section 6.3

7.4 LIMITS AND MEASUREMENT RESULTS:

LIMITS AND MEASUREMENT RESULT			
Applicable Limits	Measurement Result		
	Test Data (MHz)		Criteria
--	Bottom Channel	1.077	PASS
	Middle Channel	1.097	PASS
	Top Channel	1.109	PASS

TEST PLOT OF BANDWIDTH FOR BOTTOM CHANNEL



TEST PLOT OF BANDWIDTH FOR MIDDLE CHANNEL

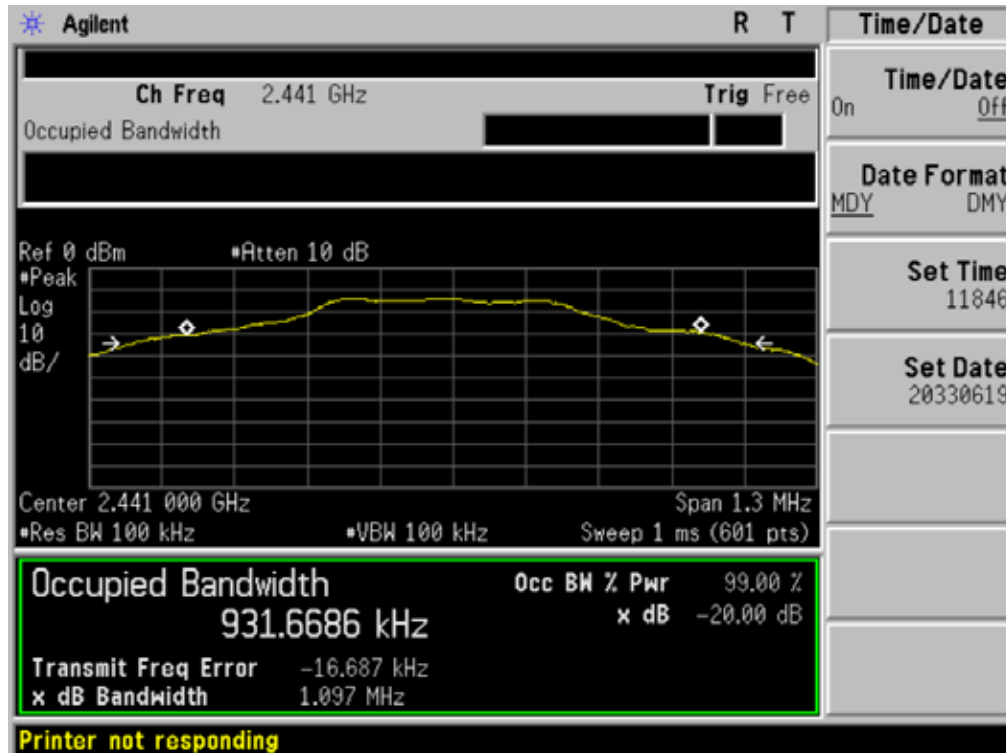

TEST PLOT OF BANDWIDTH FOR TOP CHANNEL

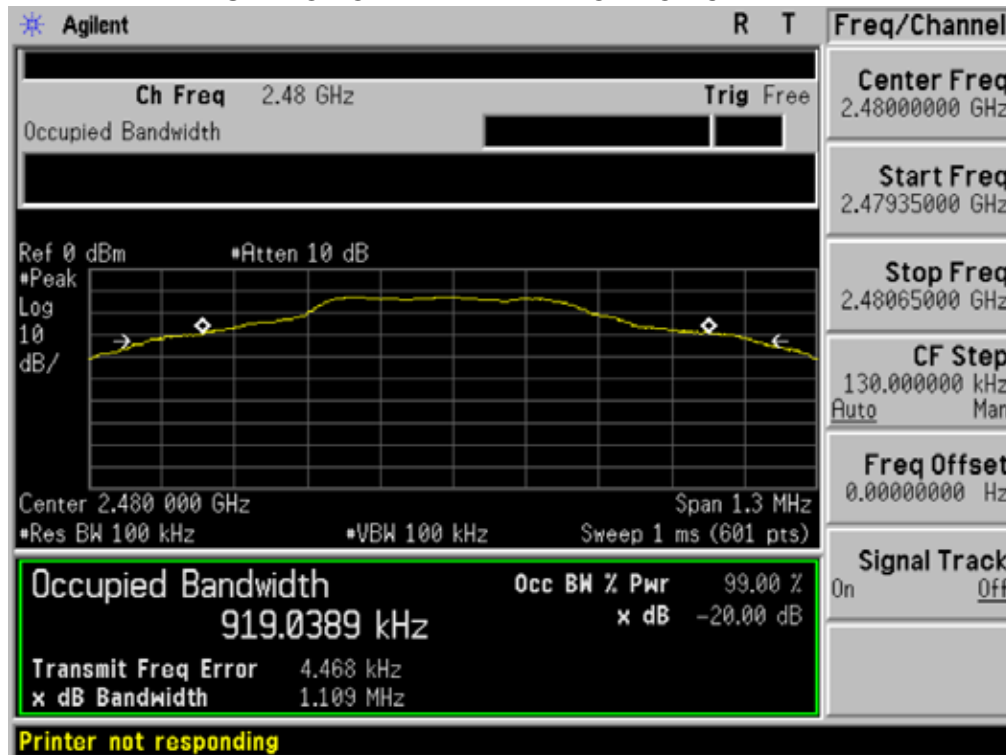

8. MAXIMUM CONDUCTED OUTPUT POWER SPECTRAL DENSITY (N/A)

8.1 MEASUREMENT PROCEDURE:

- (1). The EUT was placed on a turn table which is 0.8m above ground plane.
- (2). Connect EUT RF output port to the Spectrum Analyzer through an RF attenuator
- (3). Set the EUT Work on the top, the middle and the bottom operation frequency individually.
- (4). Set SPA Centre Frequency = Operation Frequency, RBW= 3 KHz,
VBW= 10 KHz., Sweep time= Auto
- (5). Set SPA Trace 1 Max hold, then View.

8.2 TEST SET-UP (BLOCK DIAGRAM OF CONFIGURATION)

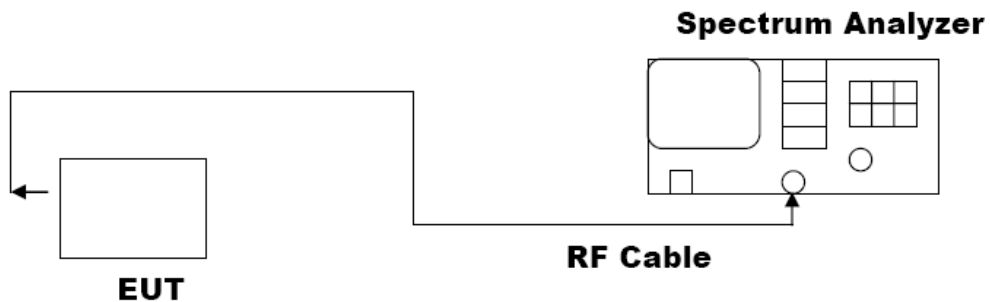

8.3 MEASUREMENT EQUIPMENT USED:

SHIELDING ROOM					
EQUIPMENT TYPE	MFR	MODEL NUMBER	SERIAL NUMBER	LAST CAL.	CAL DUE.
Spectrum Analyzer	Agilent	E4440A	US41421290	04/16/2009	04/15/2010

8.4 LIMITS AND MEASUREMENT RESULT:

LIMITS AND MEASUREMENT RESULT			
Applicable Limits	Measurement Result		
	Test Data (dBm/3KHz)		Criteria
8 dBm / 3KHz	Bottom Channel	--	--
	Middle Channel	--	--
	Top Channel	--	--

9. OUT OF BAND EMISSION

9.1 MEASUREMENT PROCEDURE:

1. The EUT was placed on a turn table which is 0.8m above ground plane.
2. Connect EUT RF output port to the Spectrum Analyzer through an RF attenuator
3. Set the EUT Work on the top, the middle and the bottom operation frequency individually.
3. Set SPA Centre Frequency = Operation Frequency, RBW= 100 KHz, VBW= 100 KHz.
4. Set SPA Trace 1 Max hold, then View.

9.2 TEST SET-UP (BLOCK DIAGRAM OF CONFIGURATION)

The Same as described in section 6.2

1. Conducted test setup
2. Radiated Emission test Setup below 1Ghz and Above 1GHz

9.3 MEASUREMENT EQUIPMENT USED:

The Same as described in section 6.3

9.4 LIMITS AND MEASUREMENT RESULT:

LIMITS AND MEASUREMENT RESULT		
Applicable Limits	Measurement Result	
	Test Data	Criteria
<p>In any 100 KHz Bandwidth Outside the frequency band in which the spread spectrum intentional radiator is operating, the radio frequency power that is produce by the intentional radiator shall be at least 20 dB below that in 100KHz bandwidth within the band that contains the highest level of the desired power.</p> <p>In addition, radiation emissions which fall in the restricted bands, as defined in §15.205(a), must also comply with the radiated emission limits specified in§15.209(a))</p>	At least -20dBc than the limit Specified on the BOTTOM Channel	PASS
	At least -20dBc than the limit Specified on the TOP Channel	PASS

TEST PLOT OF BAND ELDG FOR BOTTOM CHANNEL

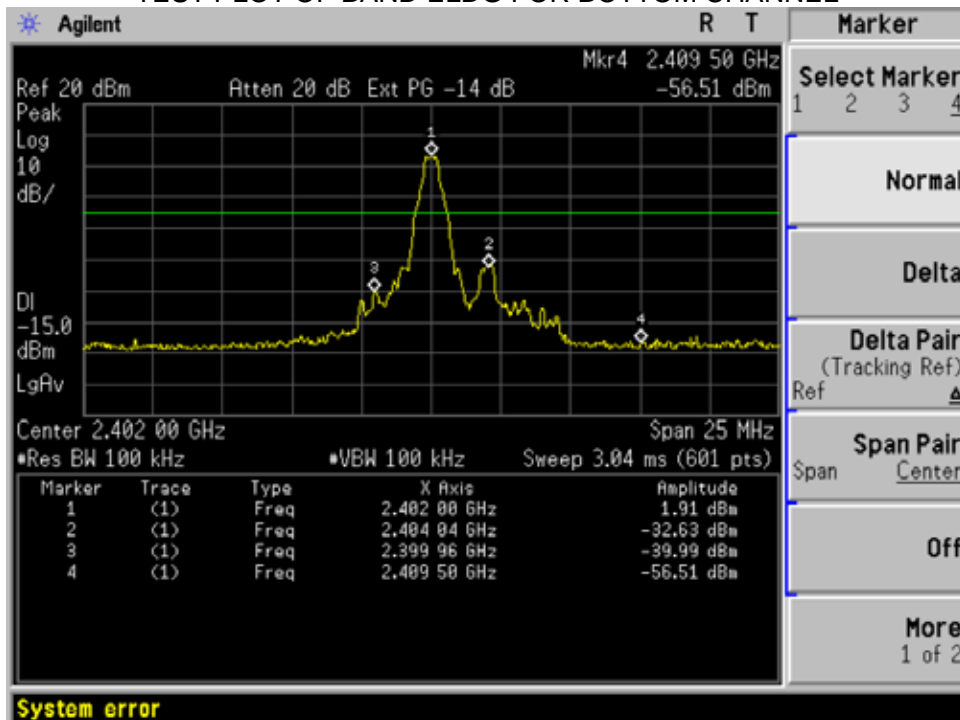

TEST PLOT OF BAND ELDG FOR TOP CHANNEL

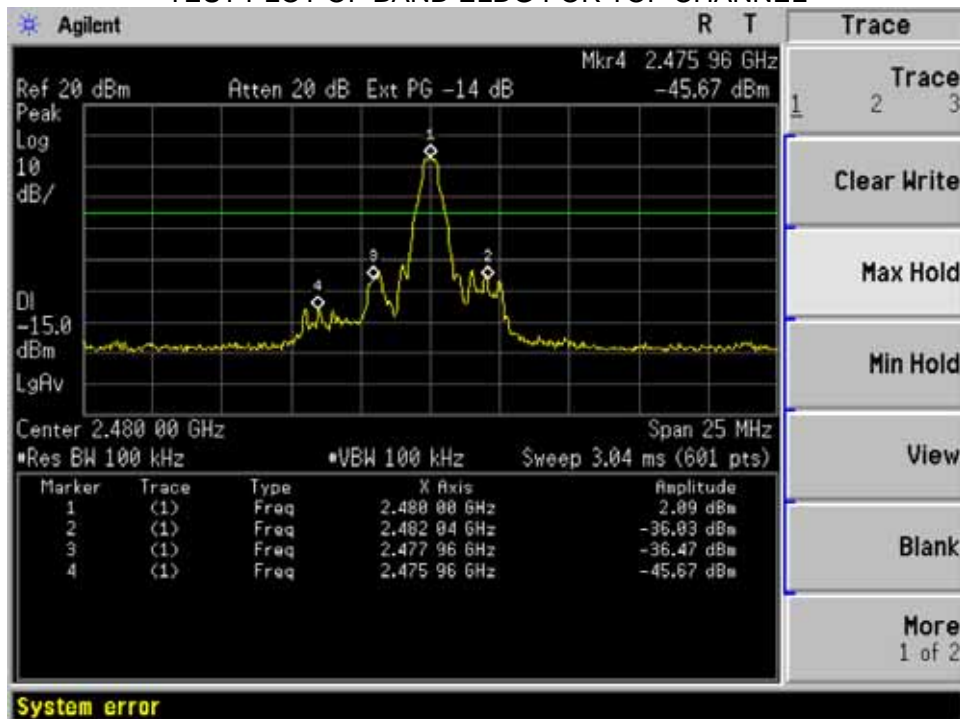

TEST PLOT OF OUT OF BAND EMISSIONS FOR BOTTOM CHANNEL - 1

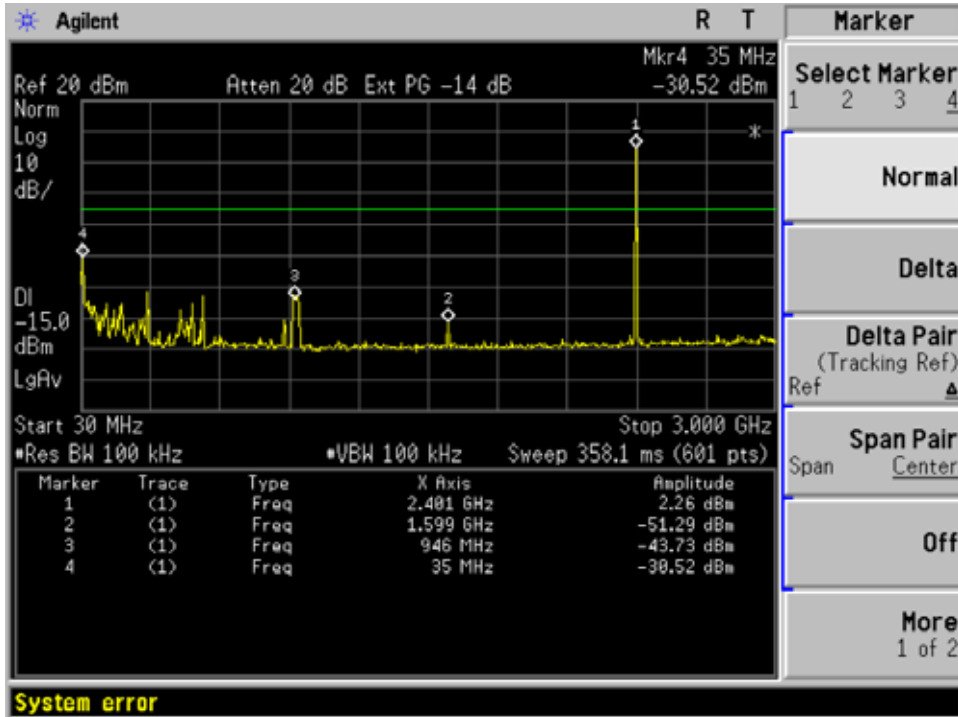

TEST PLOT OF OUT OF BAND EMISSIONS FOR BOTTOM CHANNEL - 2

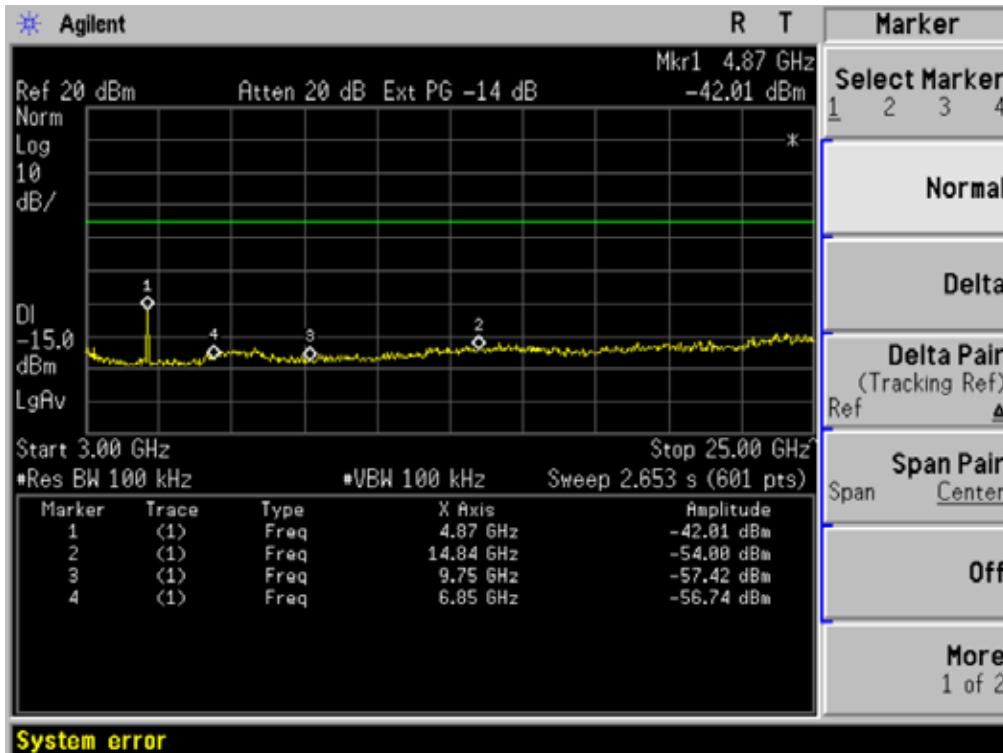

TEST PLOT OF OUT OF BAND EMISSIONS FOR MIDDLE CHANNEL – 1

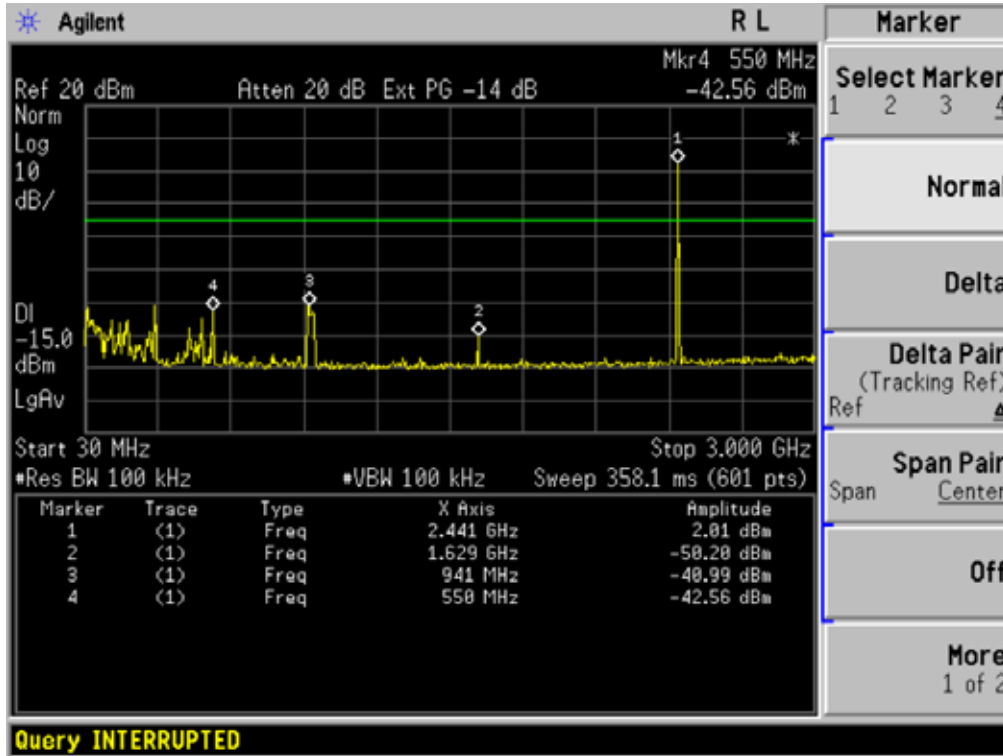

TEST PLOT OF OUT OF BAND EMISSIONS FOR MIDDLE CHANNEL – 2

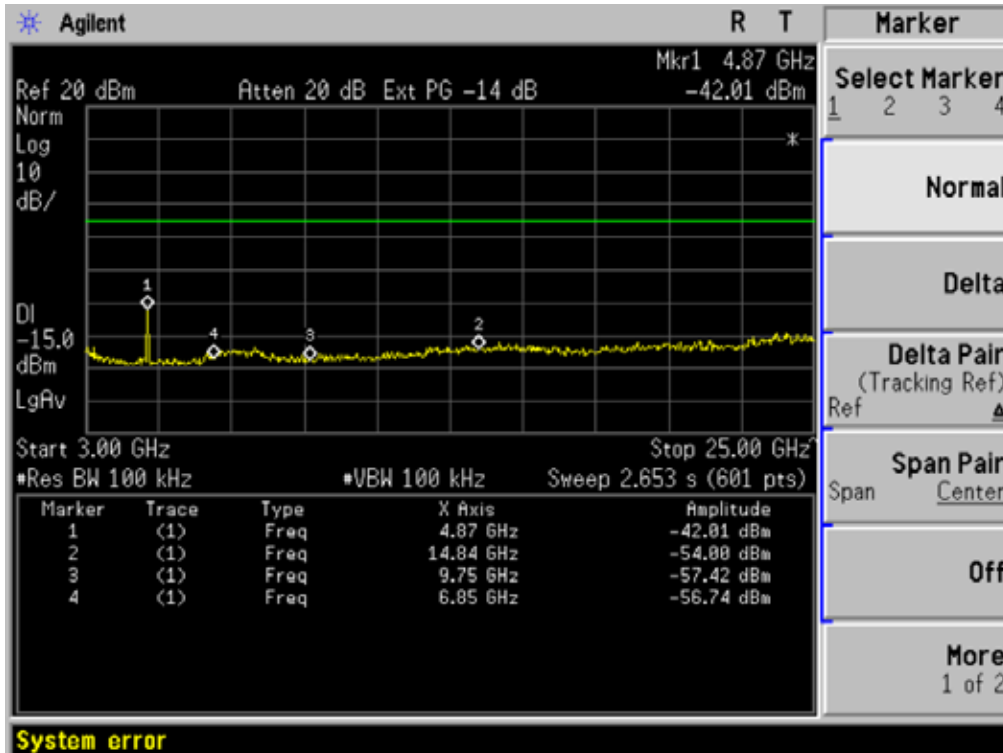

TEST PLOT OF OUT OF BAND EMISSIONS FOR TOP CHANNEL – 1

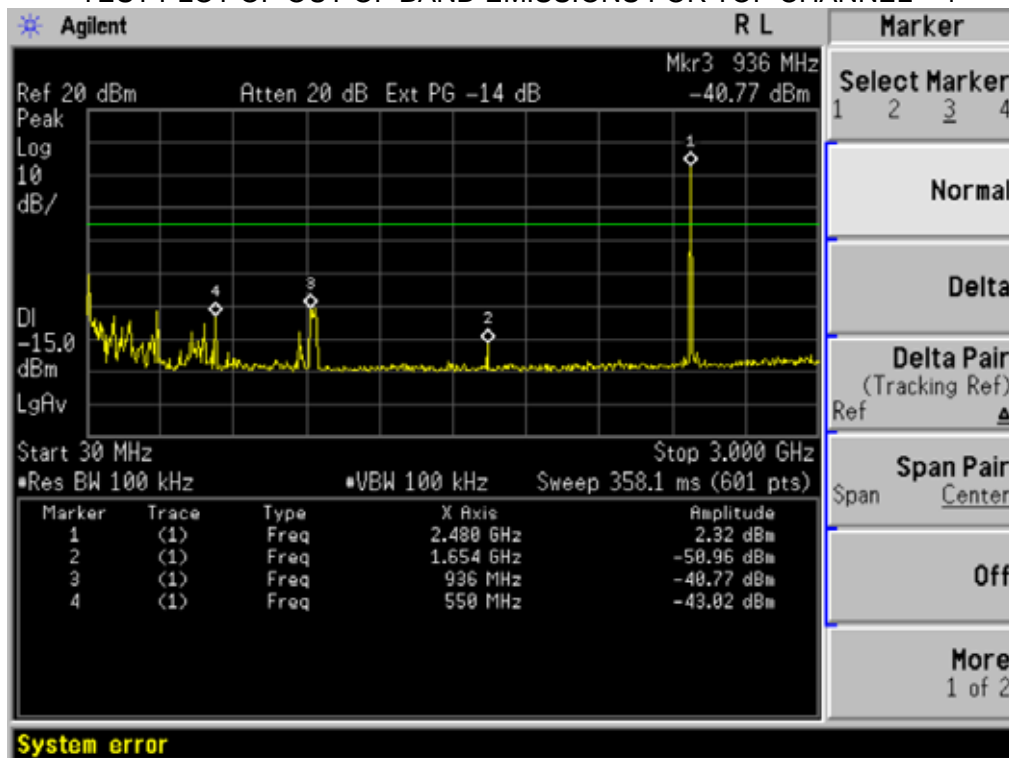

TEST PLOT OF OUT OF BAND EMISSIONS FOR TOP CHANNEL – 2

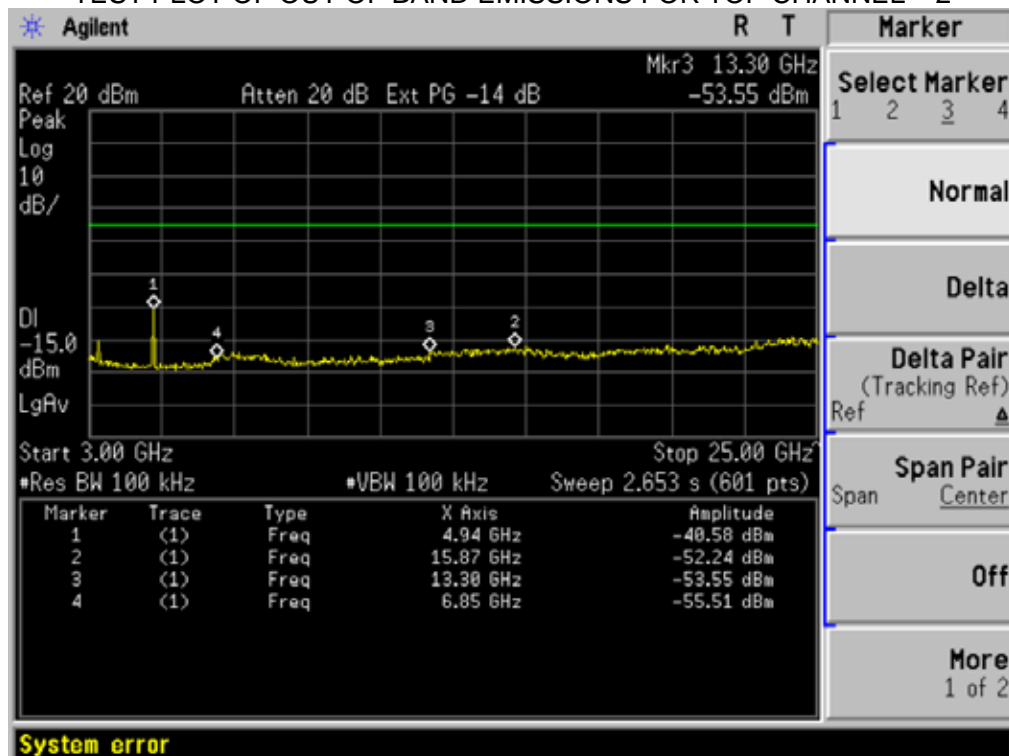

Band Edge Emission for Bottom Channel						
Frequency	Antenna Pol.	Field Strength	Field Strength	Limit (PK)	Limit (AV)	Memo
GHz	H/V	dBuV/m (PK)	dBuV/m (AV)	dBuV/m	dBuV/m	
2.386	H	55.54	43.63	74	54	*
2.400	H	52.44	47.33	74	54	*
2.386	V	53.70	42.90	74	54	*
2.400	V	51.31	46.08	74	54	*

Band Edge Emission for Top Channel						
Frequency	Antenna Pol.	Field Strength	Field Strength	Limit (PK)	Limit (AV)	Memo
GHz	H/V	dBuV/m (PK)	dBuV/m (AV)	dBuV/m	dBuV/m	
2.483	H	53.69	47.12	74	54	*
2.484	H	52.89	46.77	74	54	*
2.496	H	47.22	45.83	74	54	*
2.483	V	52.50	44.21	74	54	*
2.484	V	48.99	47.09	74	54	*
2.496	V	46.87	41.22	74	54	*

Note: This Body-worn EUT was tested in 3 orthogonal positions and the worst-case data was presented.

Restricted Band Emission for Bottom Channel						
Frequency	Antenna Pol.	Field Strength	Field Strength	Limit (PK)	Limit (AV)	Memo
GHz	H/V	dBuV/m (PK)	dBuV/m (AV)	dBuV/m	dBuV/m	
4.81	H	56.77	49.76	74	54	*
4.81	V	55.22	42.49	74	54	*
Above 4.81 GHz	H	--	--	74	54	*
	V	--	--	74	54	*

Restricted Band Emission for Middle Channel						
Frequency	Antenna Pol.	Field Strength	Field Strength	Limit (PK)	Limit (AV)	Memo
GHz	H/V	dBuV/m (PK)	dBuV/m (AV)	dBuV/m	dBuV/m	
4.88	H	57.79	47.80	74	54	*
4.88	V	56.15	47.23	74	54	*
Above 4.88 GHz	H	--	--	74	54	*
	V	--	--	74	54	*

Restricted Band Emission for Top Channel						
Frequency	Antenna Pol.	Field Strength	Field Strength	Limit (PK)	Limit (AV)	Memo
GHz	H/V	dBuV/m (PK)	dBuV/m (AV)	dBuV/m	dBuV/m	
4.95	H	58.74	46.99	74	54	*
4.95	V	53.47	44.98	74	54	*
Above 4.95GHz	H	--	--	74	54	*
	V	--	--	74	54	*

Note: This Body-worn EUT was tested in 3 orthogonal positions and the worst-case data was presented.

--" Indicated the test value is much lower to limit.

10. NUMBER OF HOPPING FREQUENCY

10.1 MEASUREMENT PROCEDURE

1. Place the EUT on the table and set it in transmitting mode.
2. Remove the antenna from the EUT and then connect a low RF cable from the antenna port to the spectrum analyzer.
3. Set the spectrum analyzer Start = 2.4GHz Stop = 2.4835GHz, Sweep = Auto
4. Set the Spectrum Analyzer as RBW = VBW = 1MHz

10.2 TEST SETUP (BLOCK DIAGRAM OF CONFIGURATION)

Same as described in section 6.2

1. Conducted Method.

10.3 MEASUREMENT EQUIPMENT USED

The Same as described in section 6.3

10.4 LIMITS AND MEASUREMENT RESULT:

TOTAL NO. OF HOPPING CHANNEL	LIMIT (NO. OF CH)	MEASUREMENT (NO. OF CH)	RESULT
		>=15	79

TEST PLOT FOR NO. OF TOTAL CHANNELS -1

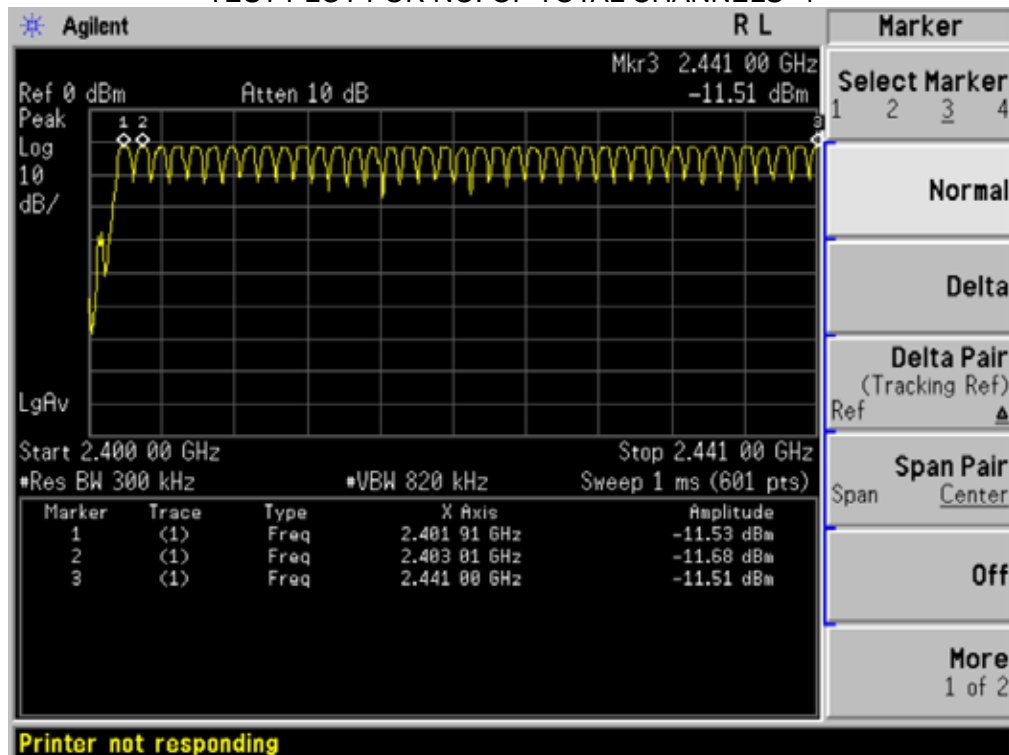

TEST PLOT FOR NO. OF TOTAL CHANNELS -2

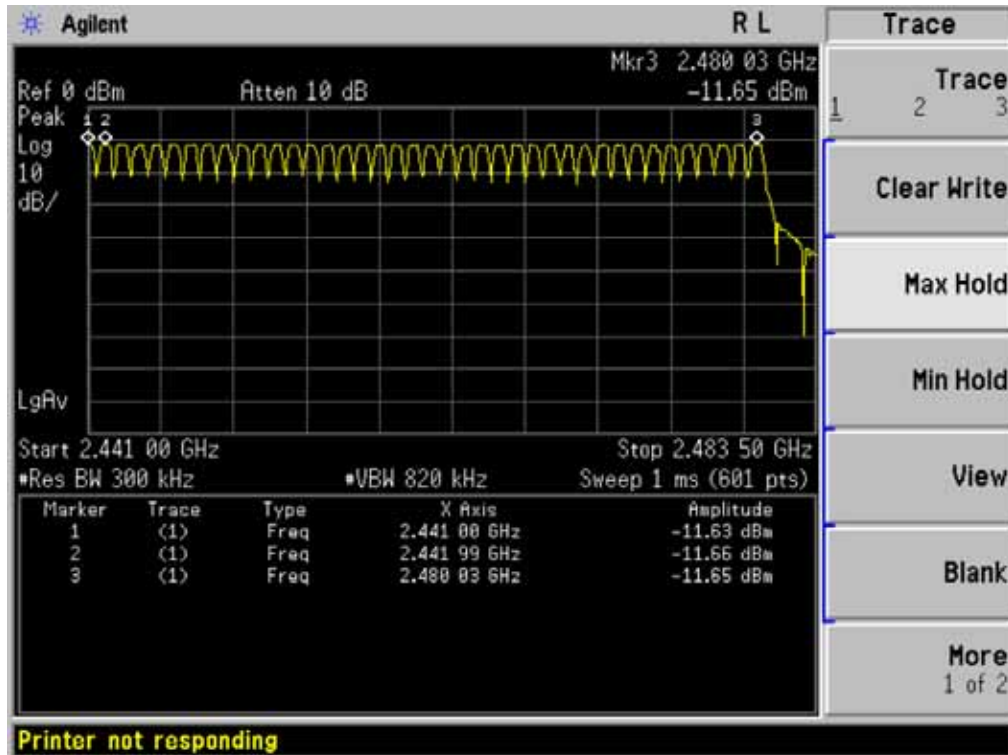

11. TIME OF OCCUPANCY (DWELL TIME)

11.1 MEASUREMENT PROCEDURE

1. Place the EUT on the table and set it in transmitting mode
2. Remove the antenna from the EUT and then connect a low RF cable from the antenna port to the spectrum analyzer
3. Set center frequency of spectrum analyzer = Operating frequency
4. Set the spectrum analyzer as RBW, VBW=1MHz, Span = 0 Hz,

11.2 TEST SETUP (BLOCK DIAGRAM OF CONFIGURATION)

Same as described in section 6.2
Conducted Method

11.3 MEASUREMENT EQUIPMENT USED

The same as described in section 6.3

11.4 LIMITS AND MEASUREMENT RESULT

The dwell time = Time Slot Length * Hop Rate / Number of Hopping Channels * 0.4 * 79

L-CH:

$$\text{DH1 Time Slot} = 0.366 \text{ (ms)} * (1600/(2*79)) * 31.6 = 117.3 \text{ (ms)}$$

$$\text{DH3 Time Slot} = 1.620 \text{ (ms)} * (1600/(4*79)) * 31.6 = 259.2 \text{ (ms)}$$

$$\text{DH5 Time Slot} = 2.850 \text{ (ms)} * (1600/(6*79)) * 31.6 = 304.0 \text{ (ms)}$$

M-CH:

$$\text{DH1 Time Slot} = 0.370 \text{ (ms)} * (1600/(2*79)) * 31.6 = 118.4 \text{ (ms)}$$

$$\text{DH3 Time Slot} = 1.620 \text{ (ms)} * (1600/(4*79)) * 31.6 = 259.2 \text{ (ms)}$$

$$\text{DH5 Time Slot} = 2.880 \text{ (ms)} * (1600/(6*79)) * 31.6 = 307.2 \text{ (ms)}$$

H-CH:

$$\text{DH1 Time Slot} = 0.366 \text{ (ms)} * (1600/(2*79)) * 31.6 = 117.3 \text{ (ms)}$$

$$\text{DH3 Time Slot} = 1.610 \text{ (ms)} * (1600/(4*79)) * 31.6 = 257.6 \text{ (ms)}$$

$$\text{DH5 Time Slot} = 2.860 \text{ (ms)} * (1600/(6*79)) * 31.6 = 305.0 \text{ (ms)}$$

TEST PLOT DH1 MODE BOTTOM CHANNEL

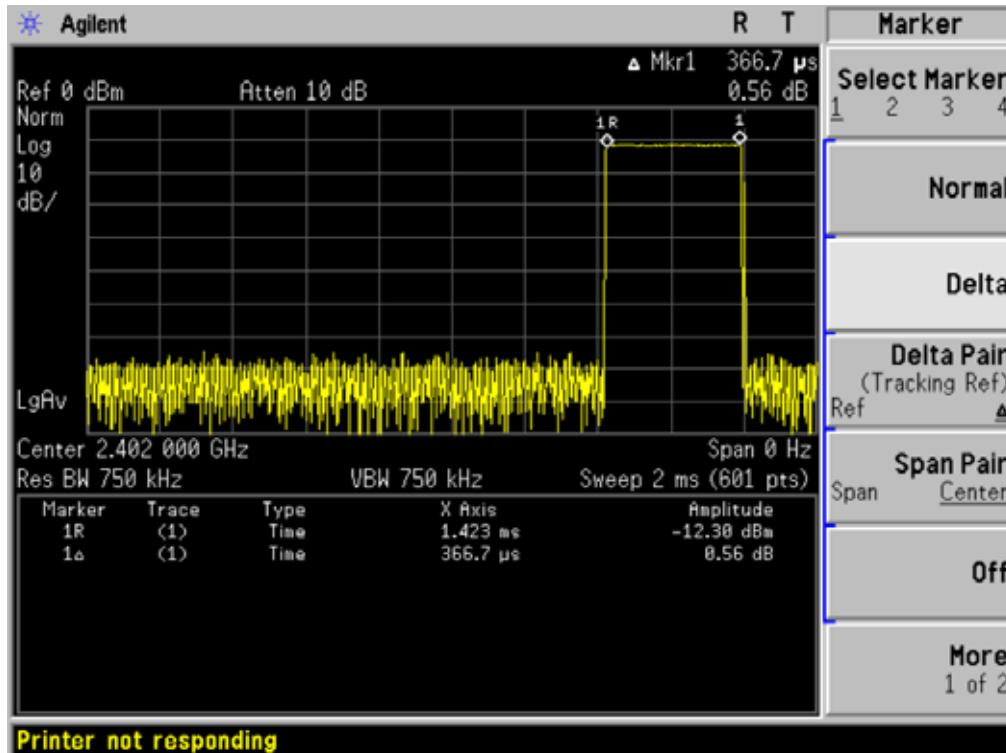

TEST PLOT DH3 MODE BOTTOM CHANNEL

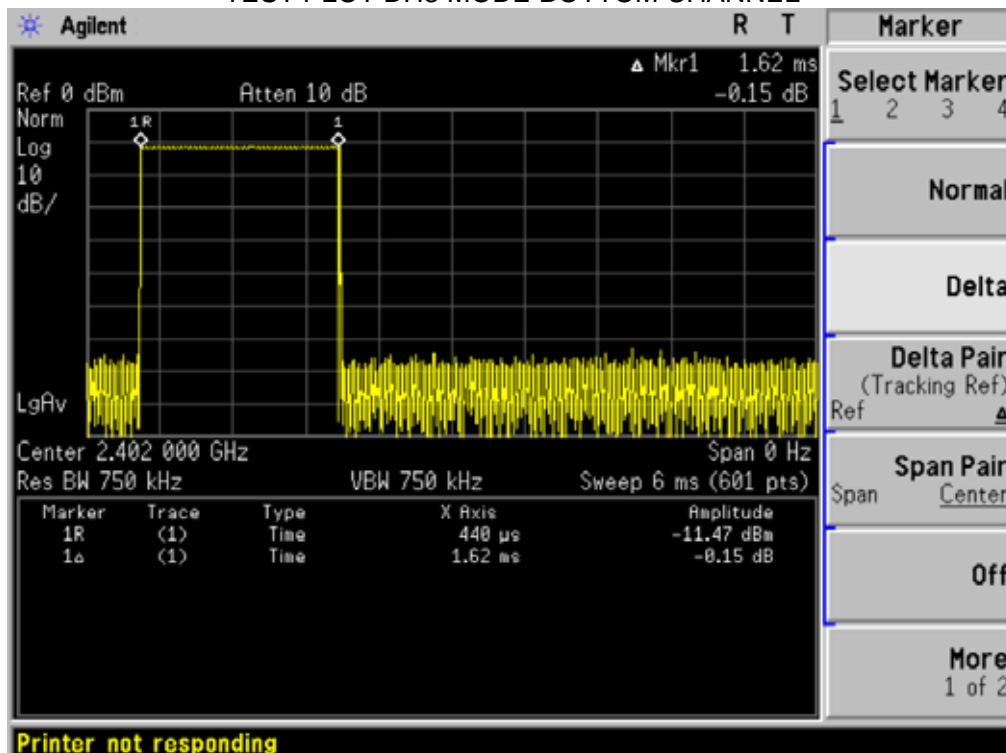

TEST PLOT DH5 MODE BOTTOM CHANNEL

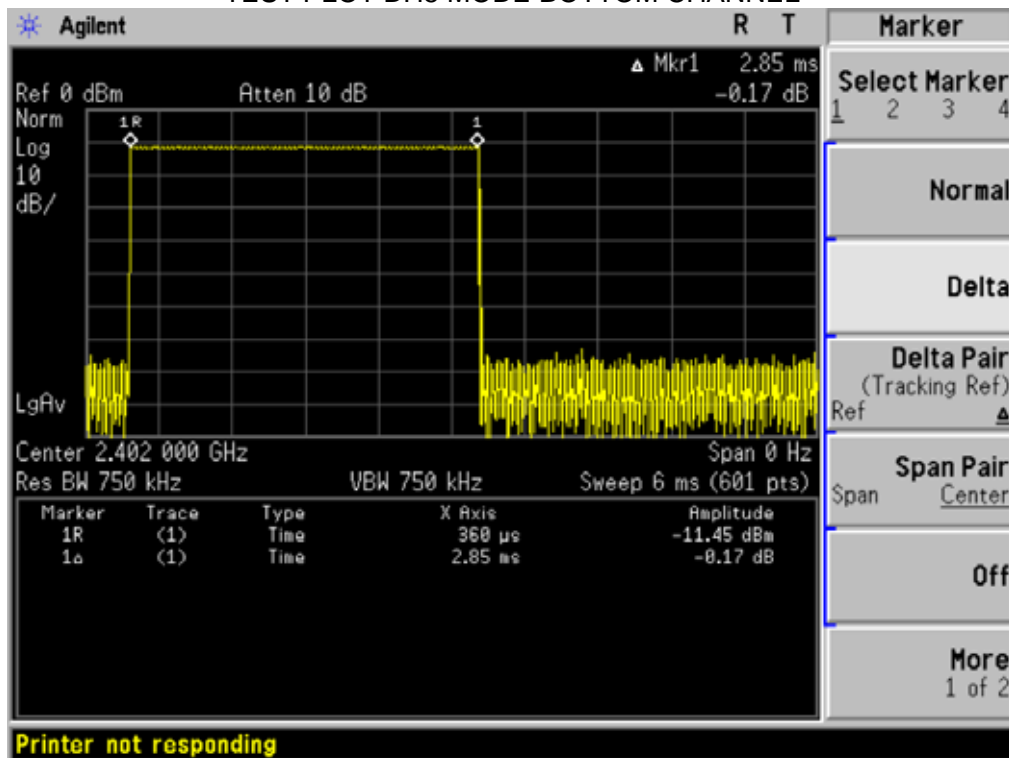

TEST PLOT DH1 MODE MIDDLE CHANNEL

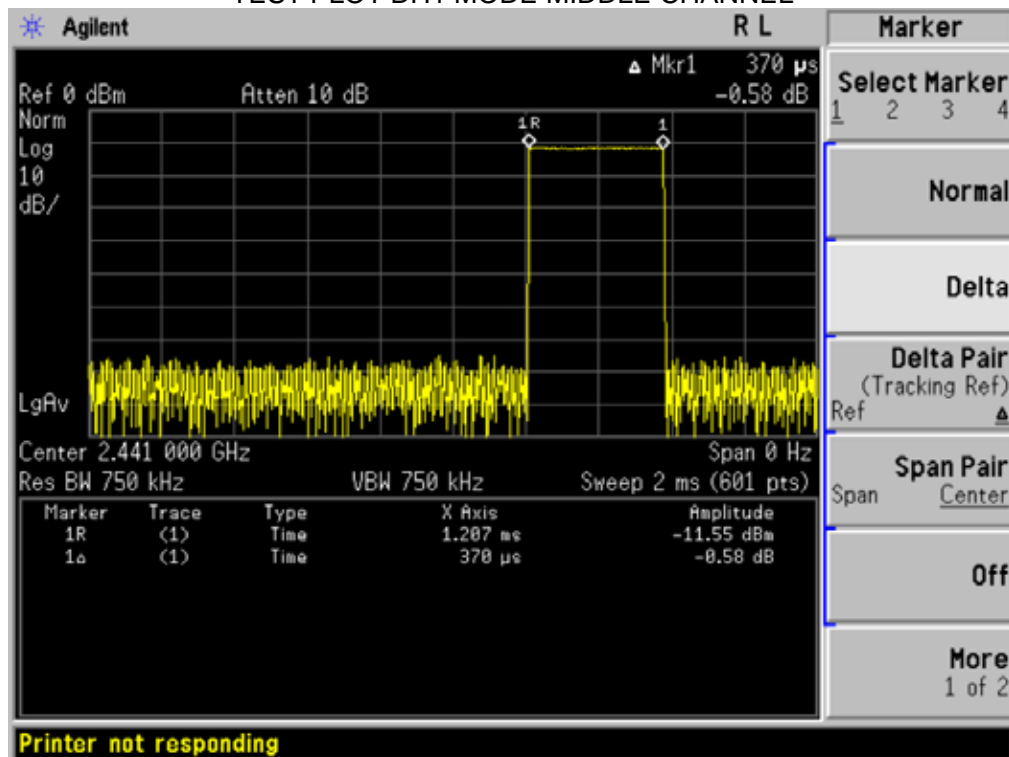

TEST PLOT DH3 MODE MIDDLE CHANNEL

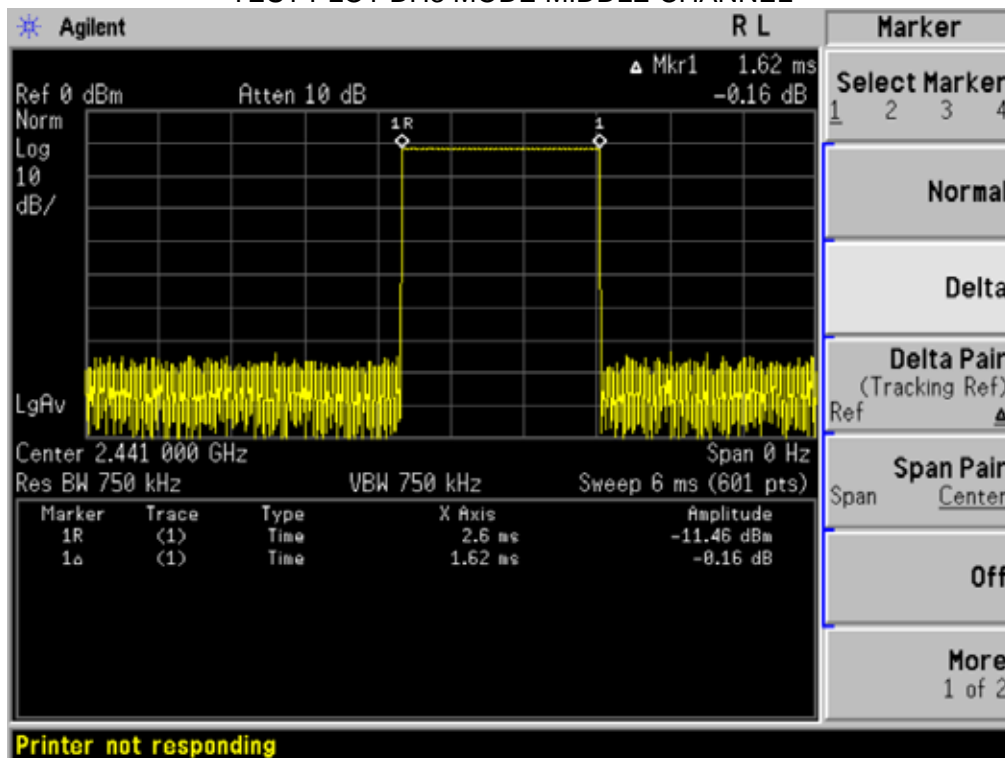

TEST PLOT DH5 MODE MIDDLE CHANNEL

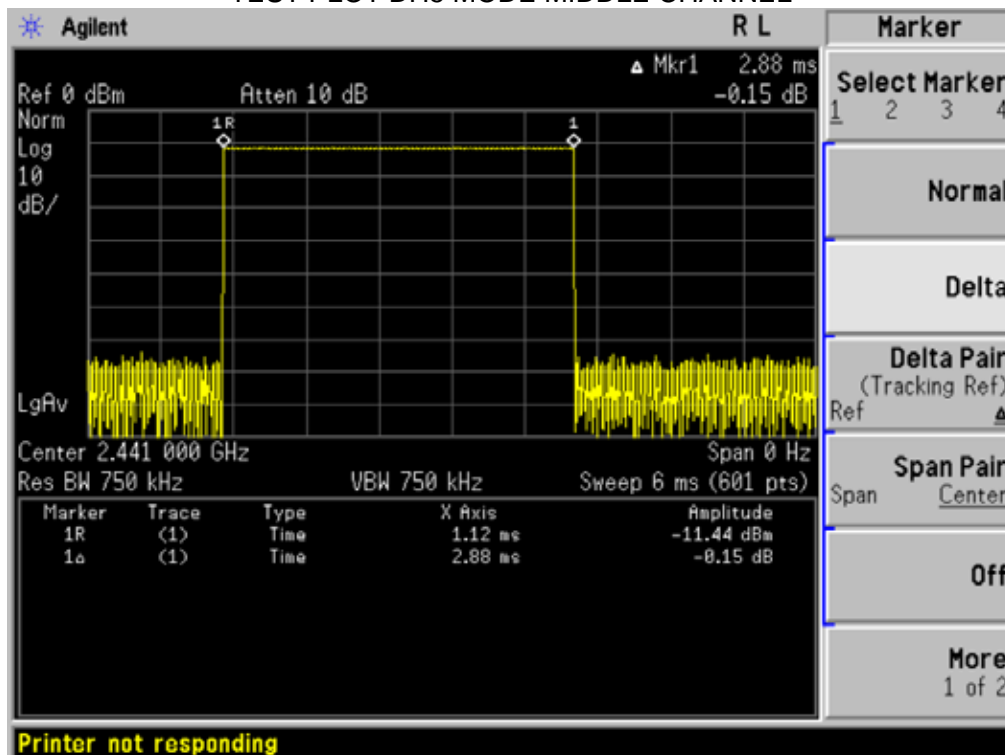

TEST PLOT DH1 MODE TOP CHANNEL

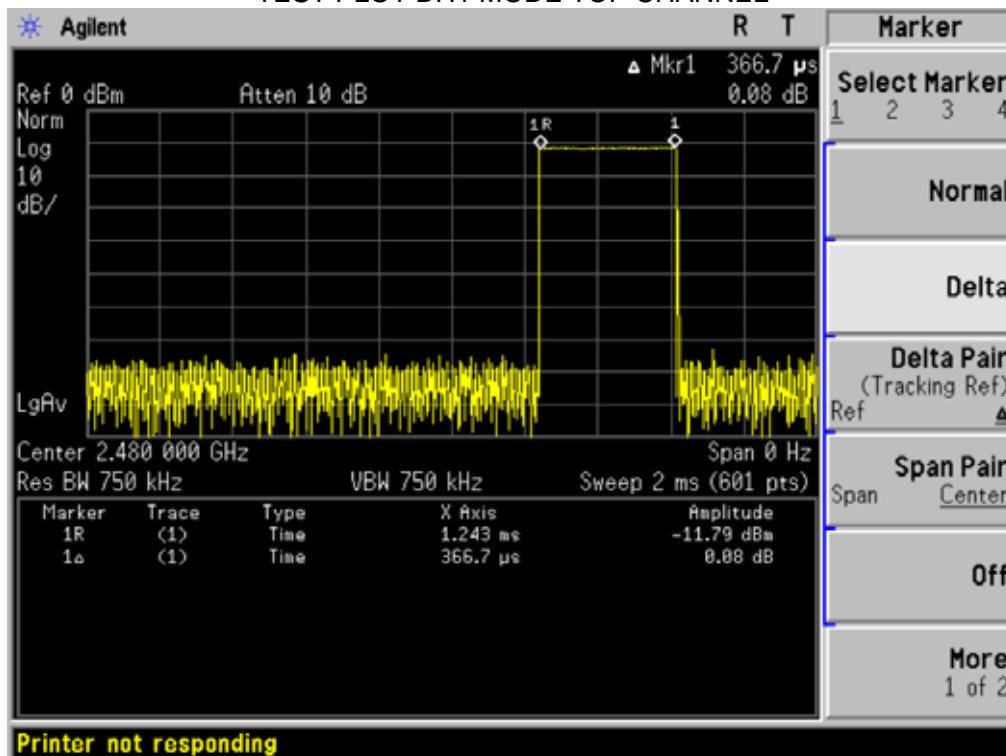

TEST PLOT DH3 MODE TOP CHANNEL

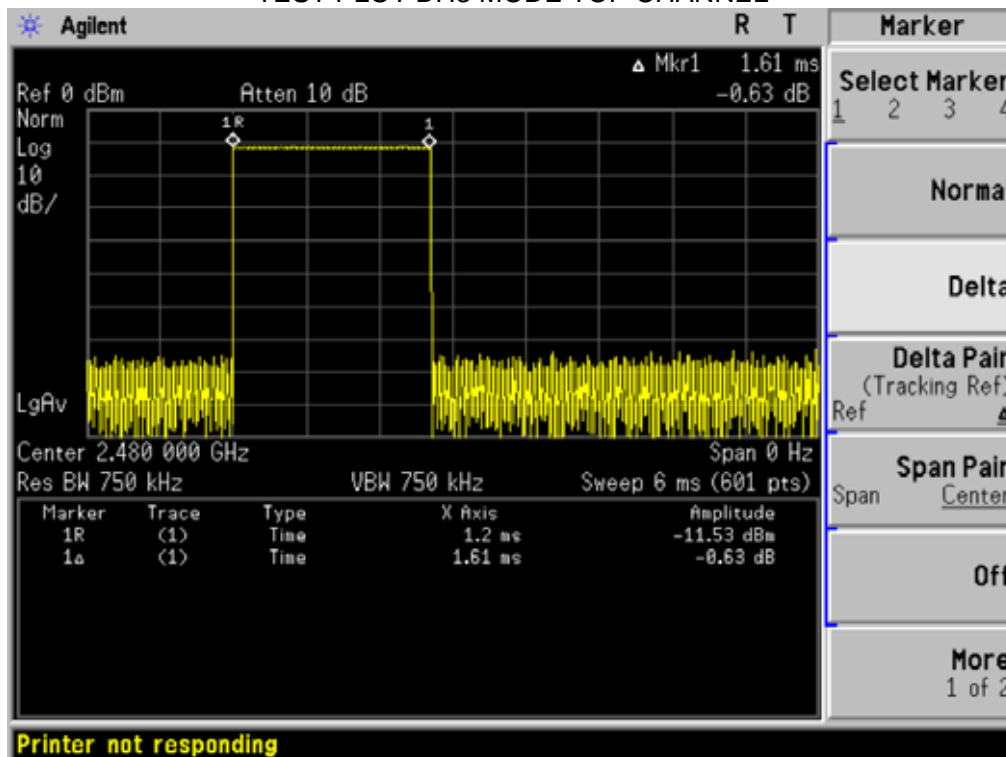

TEST PLOT DH5 MODE TOP CHANNEL

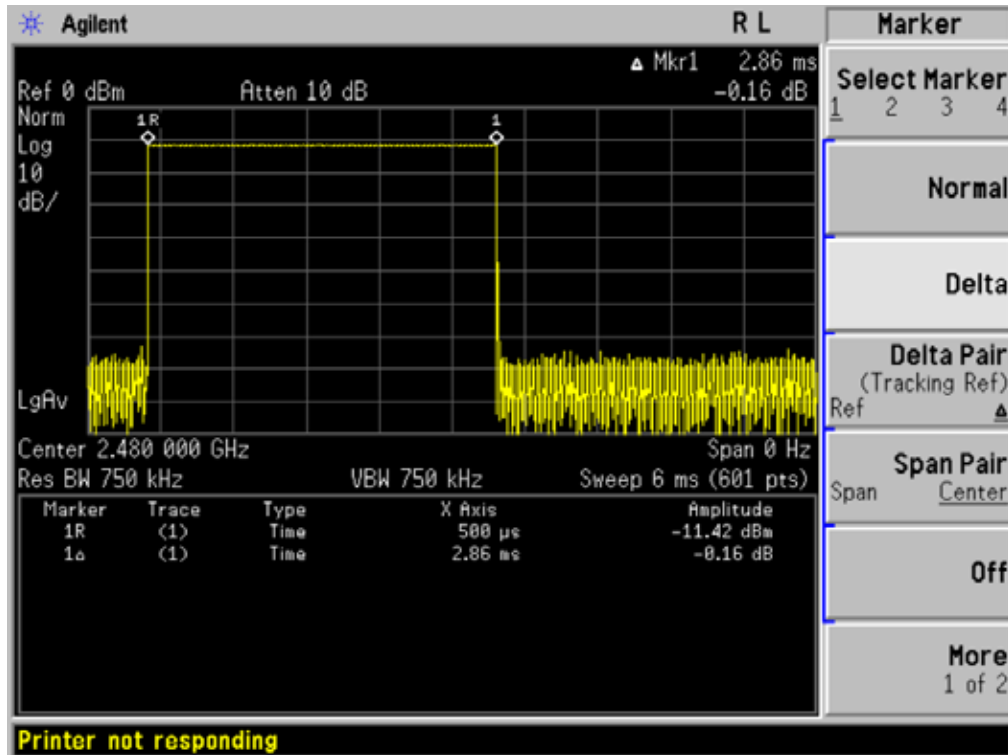

12. FREQUENCY SEPARATION
12.1 MEASUREMENT PROCEDURE

1. Place the EUT on the table and set it in transmitting mode
2. Remove the antenna from the EUT and then connect a low RF cable from the antenna port to the spectrum analyzer
3. Set center frequency of spectrum analyzer = Middle of Operating frequency
4. Set the spectrum analyzer as RBW, VBW=100KHz, Span = 5 MHz,

12.2 TEST SETUP (BLOCK DIAGRAM OF CONFIGURATION)

Same as described in section 6.2

12.3 MEASUREMENT EQUIPMENT USED

The same as described in section 6.3

12.4 LIMITS AND MEASUREMENT RESULT

CHANNEL SEPARATION	LIMIT	RESULT
KHz	KHz	Pass
1000	≥ 25 KHz or $2/3$ 20 dB BW	

TEST PLOT FOR FREQUENCY SEPARATION

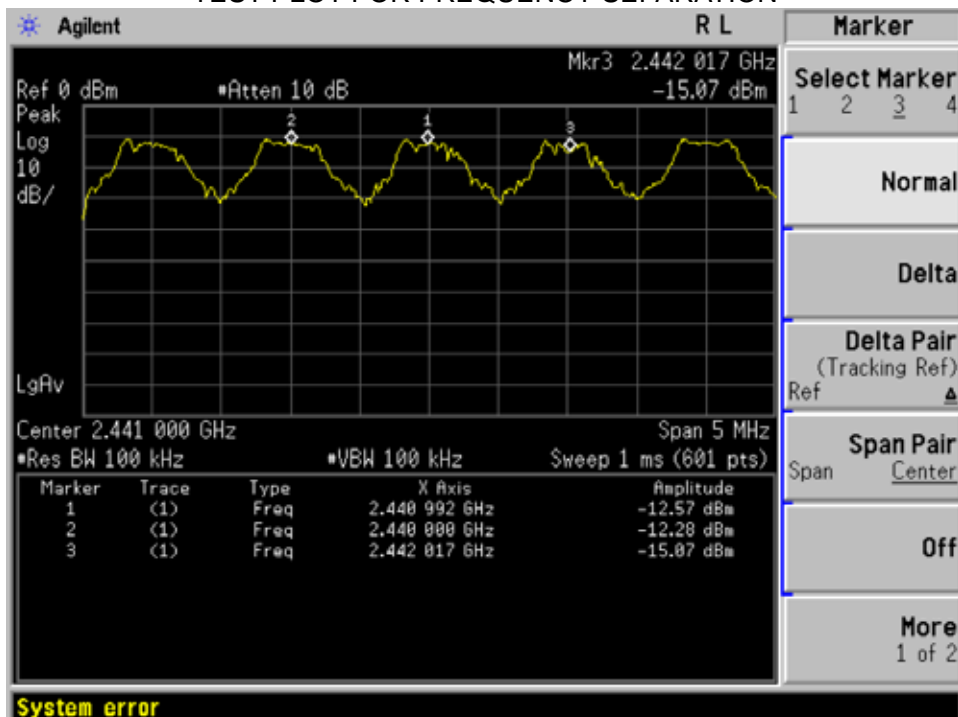

APPENDIX I
PHOTOGRAPHS OF THE EUT
ALL VIEW OF SAMP



VIEW OF SAMPLE



VIEW OF SAMPLE



INTERNAL PHOTO OF SAMPLE – 1

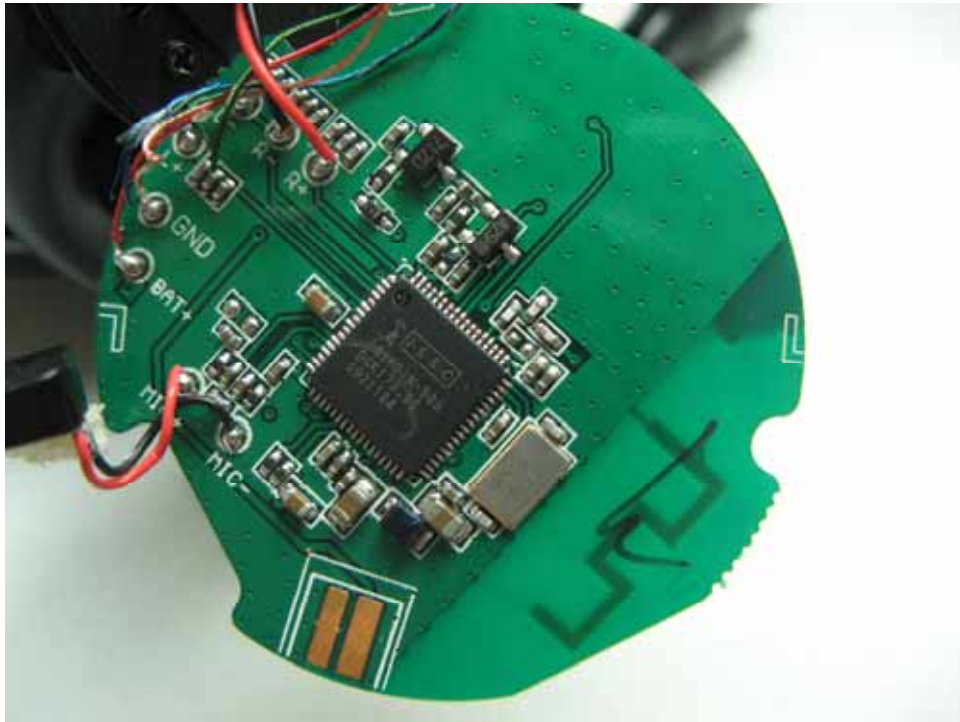

INTERNAL PHOTO OF SAMPLE – 2



PPENDIX II
PHOTOGRAPHS OF THE TEST SETUP
CONDUCTED EMISSION TEST



EIRP TEST SETUP BELOW 1GHZ



EIRP TEST SETUP ABOVE 1GHZ



RADIATED EMISSION TEST SETUP

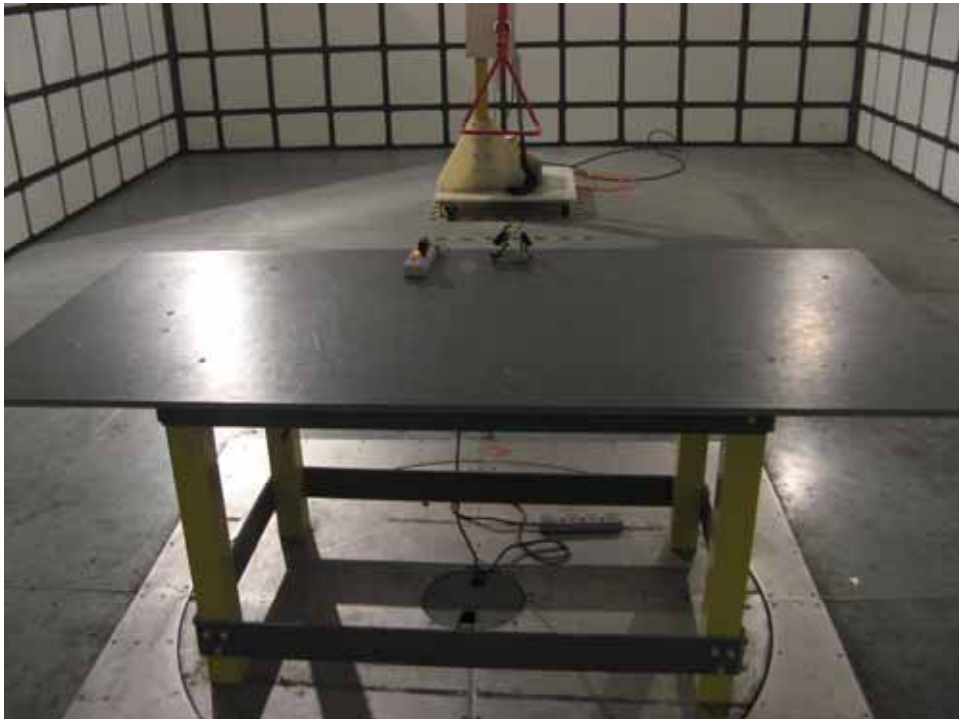

----END OF REPORT----