

# **Schematic Diagram (2.401~2.480GHz)**

FCC ID: VO8-BTH820

Model No.: BTH820

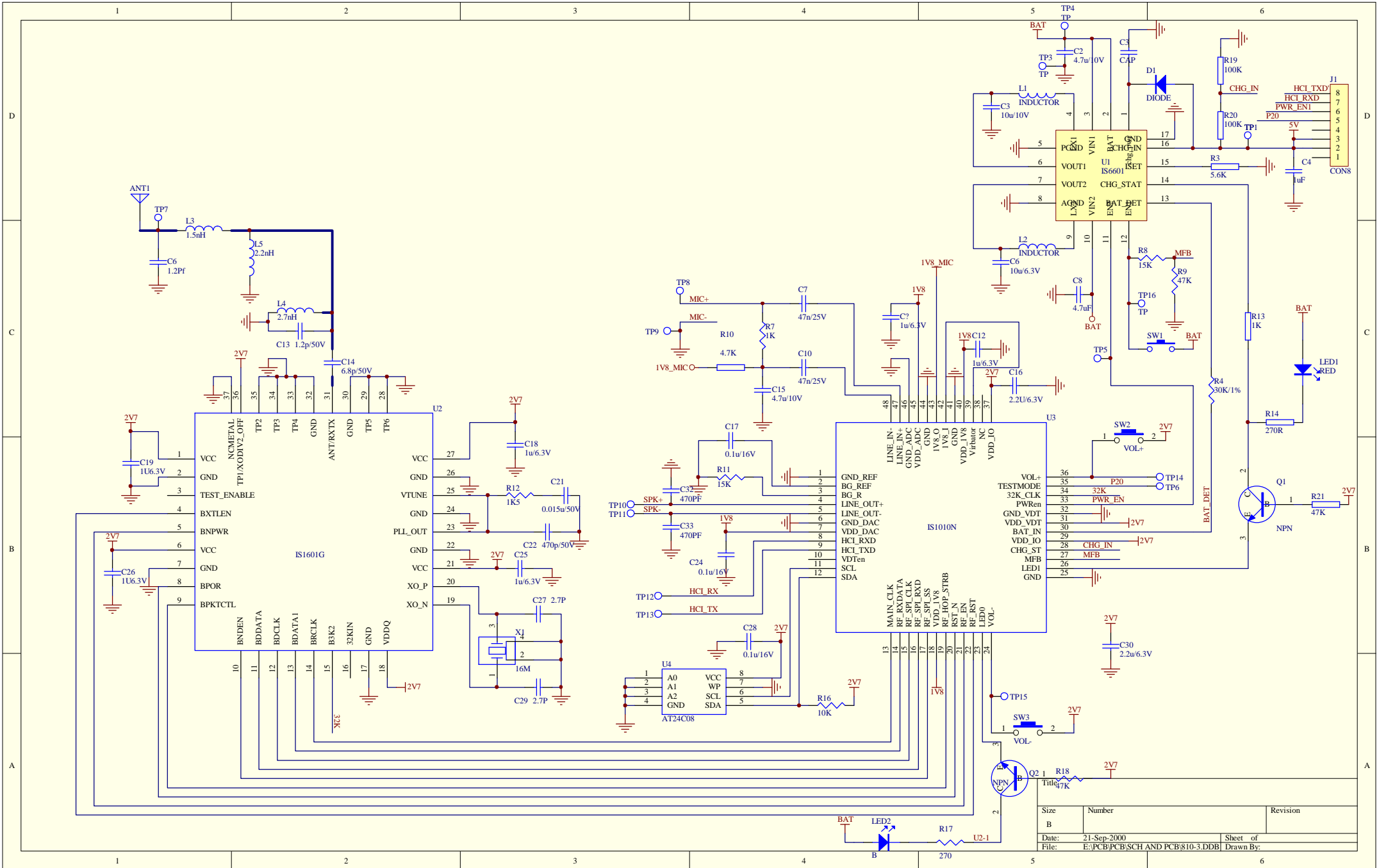

Size	Number	Revision
B		
Date:	21-Sep-2000	Sheet of
File:	E:\PCB\PCB\SCH AND PCB\810-3.DDB	Drawn By: