



FCC TEST REPORT

Test report
On Behalf of
FUJIAN NEW CENTURY COMMUNICATIONS CO., LTD
For
Mini dual band mobile radio
Model No.: KD-200UV

FCC ID: VO6-200UV

Prepared for : FUJIAN NEW CENTURY COMMUNICATIONS CO., LTD
NO.1 FENGSHOU RD., ZHAOFENG IND. ZONE, FENGZE DISTRICT, QUANZHOU,
FUJIAN, CHINA.

Prepared By : Shenzhen HUAKE Testing Technology Co., Ltd.
1F, B2 Building, Junfeng Zhongcheng Zhizao Innovation Park, Fuhai Street, Bao'an
District, Shenzhen City, China

Date of Test: Aug. 27, 2018~Oct. 31, 2018

Date of Report: Nov. 06, 2018

Report Number: HK1809111048E



TEST RESULT CERTIFICATION

Applicant's name : FUJIAN NEW CENTURY COMMUNICATIONS CO., LTD
Address : NO.1 FENGSHOU RD., ZHAOFENG IND. ZONE, FENGZE DISTRICT,
QUANZHOU, FUJIAN, CHINA.
Manufacture's Name..... : FUJIAN NEW CENTURY COMMUNICATIONS CO., LTD
Address : NO.1 FENGSHOU RD., ZHAOFENG IND. ZONE, FENGZE DISTRICT,
QUANZHOU, FUJIAN, CHINA.
Product description : Mini dual band mobile radio
Brand Name : KYDERA
Mode Name : KD-200UV
Standards : FCC Rules and Regulations Part 15B

This publication may be reproduced in whole or in part for non-commercial purposes as long as the Shenzhen HUAKE Testing Technology Co., Ltd. is acknowledged as copyright owner and source of the material. Shenzhen HUAKE Testing Technology Co., Ltd. takes no responsibility for and will not assume liability for damages resulting from the reader's interpretation of the reproduced material due to its placement and context.

Date of Test :
Date (s) of performance of tests : **Aug. 27, 2018~Oct. 31, 2018**
Date of Issue : **Nov. 06, 2018**
Test Result : **Pass**

Testing Engineer : 

(Gary Qian)

Technical Manager : 

(Eden Hu)

Authorized Signatory : 

(Jason Zhou)



Revision	Issue Date	Revisions	Revised By
V1.0	Sep. 14, 2018	Initial Issue	Jason Zhou
V1.1	Oct. 18, 2018	Updated comments	Jason Zhou
V1.2	Oct. 24, 2018	Updated comments	Jason Zhou
V1.3	Oct. 31, 2018	Updated comments	Jason Zhou
V1.4	Nov. 06, 2018	Updated comments	Jason Zhou



TABLE OF CONTENTS

1. VERIFICATION OF COMPLIANCE 5

2. PRODUCT INFORMATION 6

3. IDENTIFICATION OF THE RESPONSIBLE TESTING LOCATION 7

4. SUPPORT EQUIPMENT LIST..... 8

5. SYSTEM DESCRIPTION..... 8

6. SUMMARY OF TEST RESULTS 9

7. FCC RADIATED EMISSION TEST 10

 7.1. TEST EQUIPMENT OF RADIATED EMISSION 10

 7.2. LIMITS OF RADIATED EMISSION TEST 10

 7.3 BLOCK DIAGRAM OF RADIATED EMISSION TEST 10

 7.4 PROCEDURE OF RADIATED EMISSION TEST..... 11

 7.5 TEST RESULT OF RADIATED EMISSION TEST 12

8. ANTENNA CONDUCTED POWER FOR RECEIVERS 14

TEST RESULTS 错误! 未定义书签。

APPENDIX 1 21

PHOTOGRAPHS OF TEST SETUP..... 21

APPENDIX 2 24

PHOTOGRAPHS OF EUT..... 24



1. VERIFICATION OF COMPLIANCE

Hardware Version	CAR-M18MCU-V4.0
Software Version	V2.1UV
Measurement Procedure	ANSI C63.4: 2014
Date of test:	Aug. 27, 2018~Sep. 14, 2018
Condition of Test Sample	Normal

The test results of this report relate only to the tested sample identified in this report.



2. PRODUCT INFORMATION

The EUT is a Mini dual band mobile radio designed for voice communication. It is designed by way of utilizing the FM modulation achieves the system operating.

A major technical description of EUT is described as following:

Communication Type	Voice / Tone only
Modulation	FM
RX Frequency Range	136 MHz -174 MHz & 400 MHz -480MHz
Emission Type	F3E
DC Power Cable Length	2m
Antenna Designation	Detachable
Antenna Gain	0dBi
Power Supply	DC 13.8V
Antenna Cable Length	2m

I/O Port Information (Applicable Not Applicable)

I/O Port of EUT			
I/O Port Type	Q'TY	Cable	Tested with
DC Input Port	1	2.0m, Unshielded	1
Antenna Connect Port	1	0	1
Hand-Operated Microphone Connect Port	1	1.0 m, Unshielded	1

**3. IDENTIFICATION OF THE RESPONSIBLE TESTING LOCATION**

Site	Shenzhen HUAKE Testing Technology Co., Ltd.
Location	1F, B2 Building, Junfeng Zhongcheng Zhizao Innovation Park, Fuhai Street, Bao'an District, Shenzhen City, China
Designation Number	CN1229
Test Firm Registration Number : 616276	

TEST EQUIPMENT OF CONDUCTED EMISSION TEST

Receiver	R&S	ESCI 7	HKE-010	Dec. 29, 2017	Dec. 28, 2018
LISN	R&S	ENV216	HKE-002	Dec. 29, 2017	Dec. 28, 2018
Conducted test software	Tonscend	TS+ Rev 2.5.0.0	HKE-081	N/A	N/A
Programmable Power	GWINSTEK	PPT-1830	HKE-99	Sep. 20, 2018	Sep. 19, 2019

TEST EQUIPMENT OF RADIATED EMISSION TEST

Equipment	Manufacturer	Model	S/N	Cal. Date	Cal. Due
Broadband antenna	Schwarzbeck	VULB 9163	HKE-012	Dec. 29, 2017	Dec. 28, 2018
Receiver	R&S	ESCI 7	HKE-010	Dec. 29, 2017	Dec. 28, 2018
Preamplifier	Schwarzbeck	BBV 9743	HKE-006	Dec. 29, 2017	Dec. 28, 2018
Position controller	Taiwan MF	MF7802	HKE-011	Dec. 29, 2017	Dec. 28, 2018
Horn antenna	Schwarzbeck	9120D	HKE-013	Dec. 29, 2017	Dec. 28, 2018

ANTENNA CONDUCTED POWER FOR RECEIVERS

Equipment	Manufacturer	Model	S/N	Cal. Date	Cal. Due
EXA Signal Analyzer	AGILENT	N9010A	MY53470504	Dec. 08, 2017	Dec. 07, 2018



4. SUPPORT EQUIPMENT LIST

Device Type	Manufacturer	Model Name	Serial No.	Data Cable	Power Cable
Speaker	--	--	--	--	0.8m

5. SYSTEM DESCRIPTION

EUT test procedure:

1. Connect EUT and peripheral devices.
2. Power on the EUT, the EUT begins to work.
3. Running data transmission and make sure the EUT normal working.

EMC TEST MODES

No.	TEST MODES
1	Scanning mode + Receiving mode
2	No scanning mode

Note:

Only the result of the worst case was recorded in the report.



6. SUMMARY OF TEST RESULTS

FCC Rules	Description Of Test	Result
§15.107	Conduction Emission	Compliant
§15.109	Radiated Emission	Compliant
§15.111	Antenna Conducted Power for receivers	Compliant



7. FCC RADIATED EMISSION TEST

7.1. TEST EQUIPMENT OF RADIATED EMISSION

7.2. LIMITS OF RADIATED EMISSION TEST

Frequency (MHz)	Distance (m)	Maximum Field Strength Limit (dBuV/m/ Q.P.)
30~88	3	40.0
88~216	3	43.5
216~960	3	46.0
Above 960	3	54.0

**Note: The lower limit shall apply at the transition frequency.

7.3 BLOCK DIAGRAM OF RADIATED EMISSION TEST

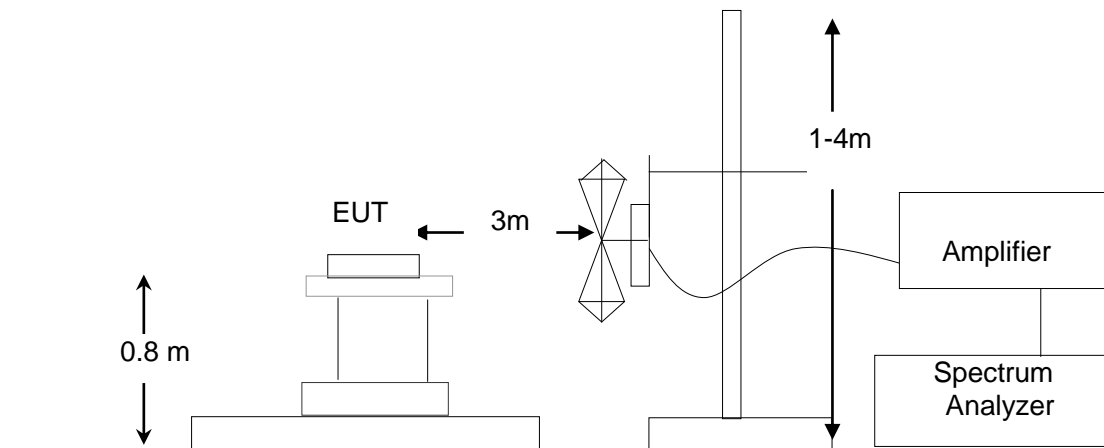



7.4 PROCEDURE OF RADIATED EMISSION TEST

- 1) The equipment was set up as per the test configuration to simulate typical actual usage per the user's manual. When the EUT is a tabletop system, a wooden turntable with a height of 0.8 meters is used which is placed on the ground plane as per ANSI C63.4 (see Test Facility for the dimensions of the ground plane used). When the EUT is floor-standing equipment, it is placed on the ground plane which has a 3-12 mm non-conductive covering to insulate the EUT from the ground plane.
- 2) Support equipment, if needed, was placed as per ANSI C63.4.
- 3) All I/O cables were positioned to simulate typical actual usage as per ANSI C63.4.
- 4) The EUT received power by DC source. All support equipments received AC 120V/60Hz power from socket under the turntable, if any.
- 5) The antenna was placed at 3 meter away from the EUT as stated in FCC Part 15. The antenna connected to the Analyzer via a cable and at times a pre-amplifier would be used.
- 6) The Analyzer / Receiver quickly scanned from 30MHz to 1000MHz. The EUT test program was started. Emissions were scanned and measured rotating the EUT to 360 degrees and positioning the antenna 1 to 4 meters above the ground plane, in both the vertical and the horizontal polarization, to maximize the emission reading level.
- 7) The test mode(s) were scanned during the test:
- 8) Recorded at least the six highest emissions. Emission frequency, amplitude, antenna position, polarization and turntable position were recorded into a computer in which correction factors were used to calculate the emission level and compare reading to the applicable limit and Q.P./Peak reading is presented.

The test data of the worst case condition (mode 1) was reported on the following Data page



7.5 TEST RESULT OF RADIATED EMISSION TEST

Radiated Emission Test –Horizontal -3m Below 1G

66.9 dBuV/m

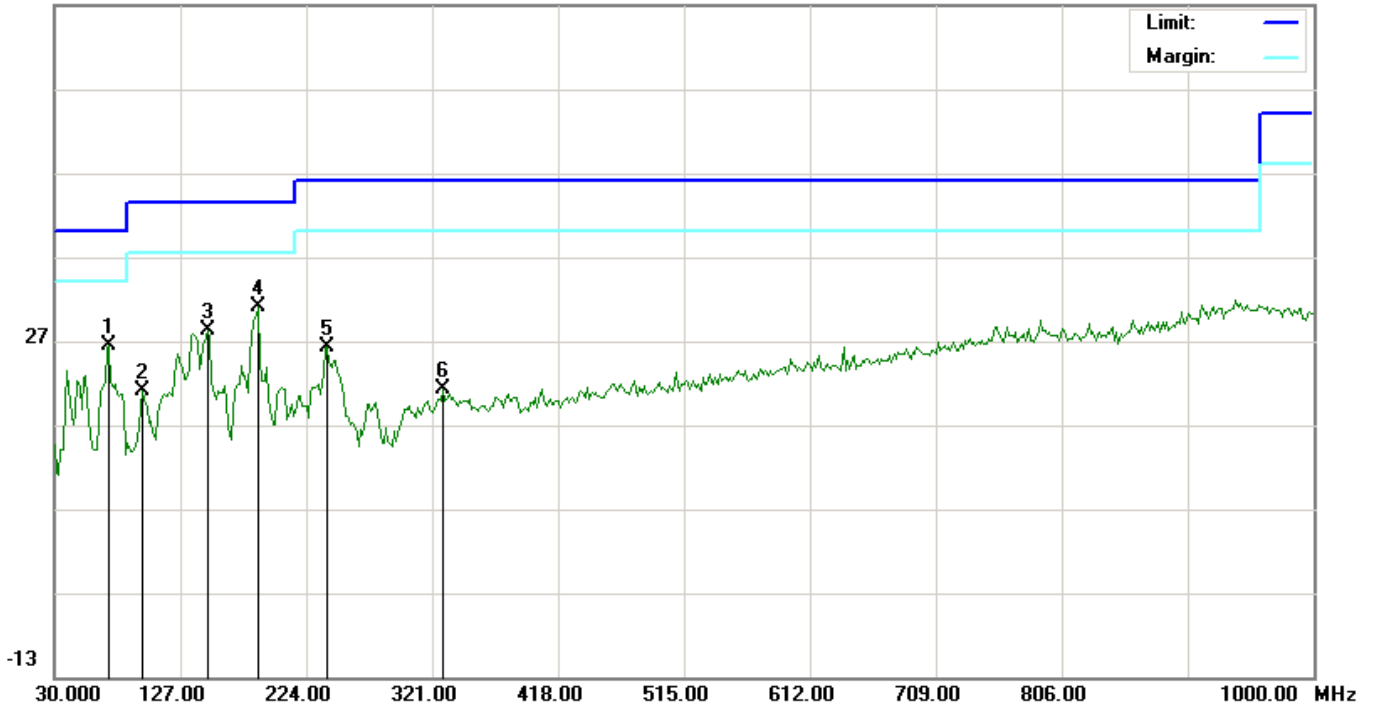

No.	Mk	Freq.	Reading	Factor	Measurement	Limit	Over	Detector	Antenna Height	Table Degree	Comment
		MHz	dBuV	dB/m	dBuV/m	dBuV/m	dB		cm	degree	
1		72.0333	18.10	8.28	26.38	40.00	-13.62	peak			
2		97.9000	12.62	8.38	21.00	43.50	-22.50	peak			
3		148.0166	15.04	13.25	28.29	43.50	-15.21	peak			
4	*	186.8167	19.61	11.39	31.00	43.50	-12.50	peak			
5		240.1667	18.39	7.90	26.29	46.00	-19.71	peak			
6		329.0833	3.95	17.35	21.30	46.00	-24.70	peak			

RESULT: PASS



Radiated Emission Test –Vertical -3m Below 1G

66.9 dBuV/m

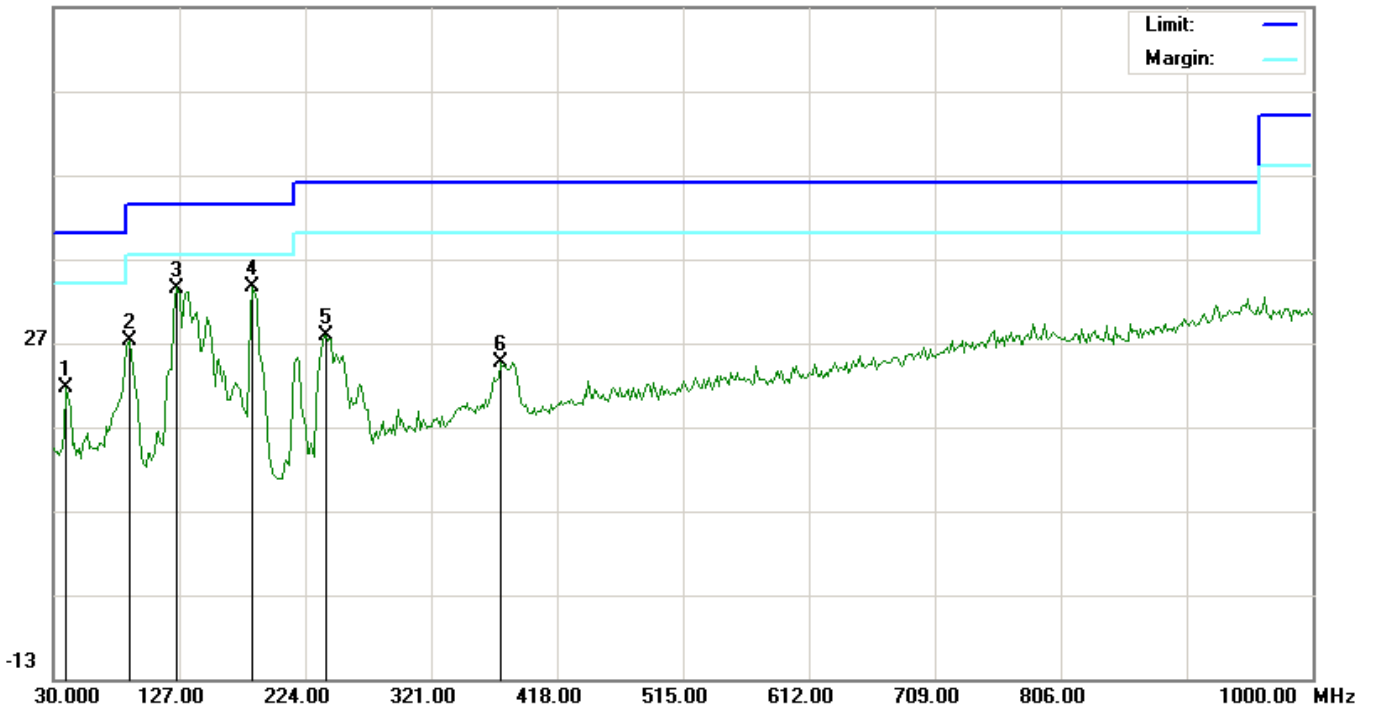

No.	Mk	Freq.	Reading	Factor	Measurement	Limit	Over	Detector	Antenna	Table	Comment
		MHz	dBuV	dB/m	dBuV/m	dBuV/m	dB		Height	Degree	
									cm	degree	
1		39.7000	13.04	8.51	21.55	40.00	-18.45	peak			
2		88.2000	22.41	4.74	27.15	43.50	-16.35	peak			
3		125.3833	24.40	9.10	33.50	43.50	-10.00	peak			
4	*	183.5833	20.51	13.16	33.67	43.50	-9.83	peak			
5		240.1667	14.87	12.94	27.81	46.00	-18.19	peak			
6		374.3500	5.72	18.90	24.62	46.00	-21.38	peak			

RESULT: PASS

- Note:**
1. Factor=Antenna Factor + Cable loss - Amplifier gain, Margin = Limit–Measurement.
 2. The “Factor” value can be calculated automatically by software of measurement system.
 3. Emissions range from 1GHz to 2GHz have 20dB margin. No recording in the test report.
 4. Only the data of the worst case would be record in this test report.



8. CONDUCTED EMISSION TEST

8.1 PROVISIONS APPLICABLE

For an intentional radiator that is designed to be connected to the public utility (AC) power line, the radio frequency voltage that is conducted back onto the AC power line on any frequencies within the band 150 KHz to 30 MHz shall not exceed the limits in the following table, as measured using a 50uH/50 ohms line impedance stabilization network (LISN). Compliance with the provisions of this paragraph shall be based on the measurement of the radio frequency voltage between each power line and ground at the power terminal. The lower limit applies at the boundary between the frequencies ranges.

Frequency of Emission (MHz)	Conducted Limit(dBuV)	
	Quasi-Peak	Average
0.15 – 0.5	66 to 56 *	56 to 46 *
0.5 – 5	56	46
5 – 30	60	50

* Decreases with the logarithm of the frequency.

8.2 MEASUREMENT PROCEDURE

- (1) The equipment was set up as per the test configuration to simulate typical actual usage per the user's manual. When the EUT is a tabletop system, a wooden table with a height of 0.8 meters is used and is placed on the ground plane as per ANSI C63.4 (see Test Facility for the dimensions of the ground plane used). When the EUT is a floor-standing equipment, it is placed on the ground plane which has a 3-12 mm non-conductive covering to insulate the EUT from the ground plane.
- (2) Support equipment, if needed, was placed as per ANSI C63.4.
- (3) All I/O cables were positioned to simulate typical actual usage as per ANSI C63.4.
- (4) The EUT received AC 120V/60Hz power through a Line Impedance Stabilization Network (LISN) which supplied power source and was grounded to the ground plane.
- (5) All support equipments received AC power from a second LISN, if any.
- (6) The EUT test program was started. Emissions were measured on each current carrying line of the EUT using a spectrum Analyzer / Receiver connected to the LISN powering the EUT. The LISN has two monitoring points: Line 1 (Hot Side) and Line 2 (Neutral Side). Two scans were taken: one with Line 1 connected to Analyzer / Receiver and Line 2 connected to a 50 ohm load; the second scan had Line 1 connected to a 50 ohm load and Line 2 connected to the Analyzer / Receiver.
- (7) Analyzer / Receiver scanned from 150 KHz to 30MHz for emissions in each of the test modes.

During the above scans, the emissions were maximized by cable manipulation.



8.3 TEST SETUP BLOCK DIAGRAM

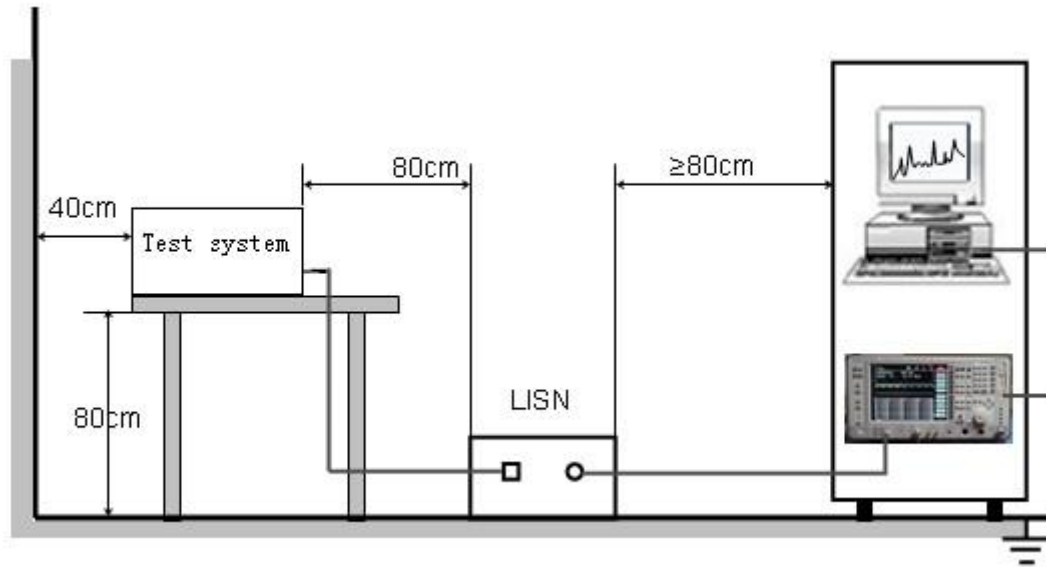



8.4 TEST RESULT

CONDUCTED EMISSION TEST – LINE L

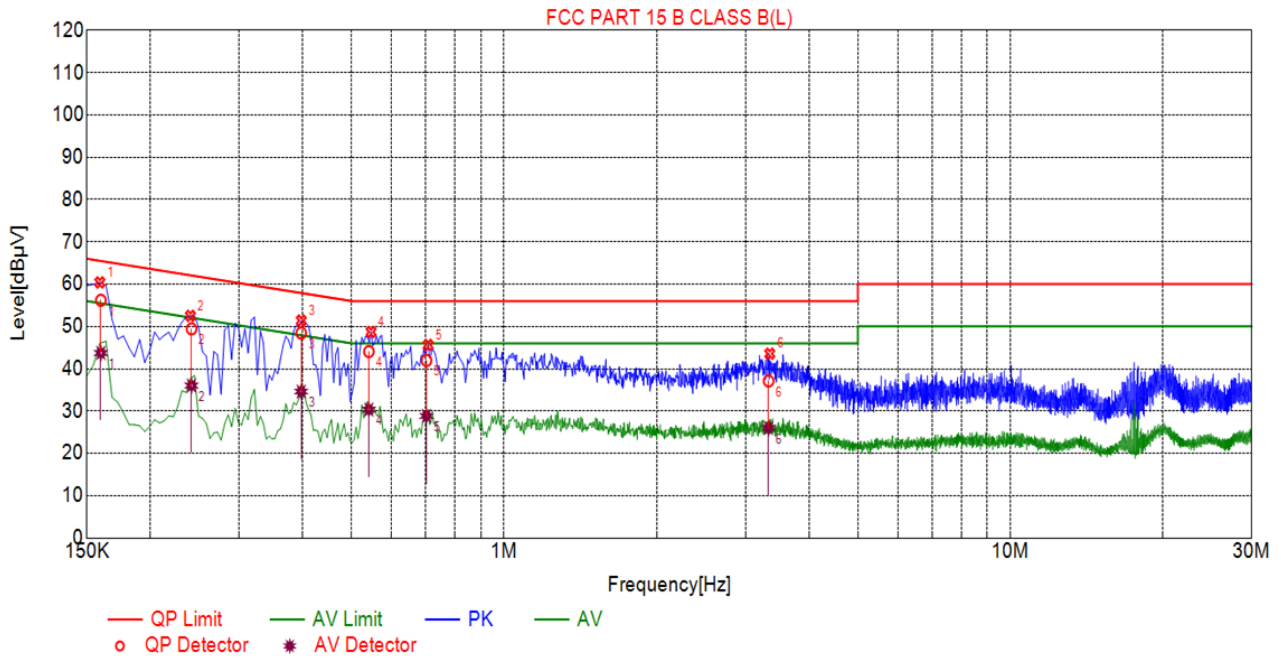

Suspected List						
NO.	Freq. [MHz]	Level [dBµV]	Factor [dB]	Limit [dBµV]	Margin [dB]	Detector
1	0.1590	60.41	10.01	65.52	5.11	PK
2	0.2400	52.51	10.03	62.10	9.59	PK
3	0.3975	51.40	10.04	57.91	6.51	PK
4	0.5460	48.70	10.06	56.00	7.30	PK
5	0.7080	45.63	10.05	56.00	10.37	PK
6	3.3495	43.56	10.24	56.00	12.44	PK

Final Data List								
NO.	Freq. [MHz]	Factor [dB]	QP Value [dBµV]	QP Limit [dBµV]	QP Margin [dB]	AV Value [dBµV]	AV Limit [dBµV]	AV Margin [dB]
1	0.1597	10.00	56.20	65.48	9.28	43.73	55.48	11.75
2	0.2412	10.03	49.44	62.05	12.61	36.03	52.05	16.02
3	0.3973	10.04	48.46	57.91	9.45	34.62	47.91	13.29
4	0.5405	10.05	44.06	56.00	11.94	30.36	46.00	15.64
5	0.7024	10.05	41.98	56.00	14.02	28.85	46.00	17.15
6	3.3306	10.24	37.11	56.00	18.89	26.02	46.00	19.98

RESULT: PASS



CONDUCTED EMISSION TEST – LINE N

FCC PART 15 B CLASS B(N)

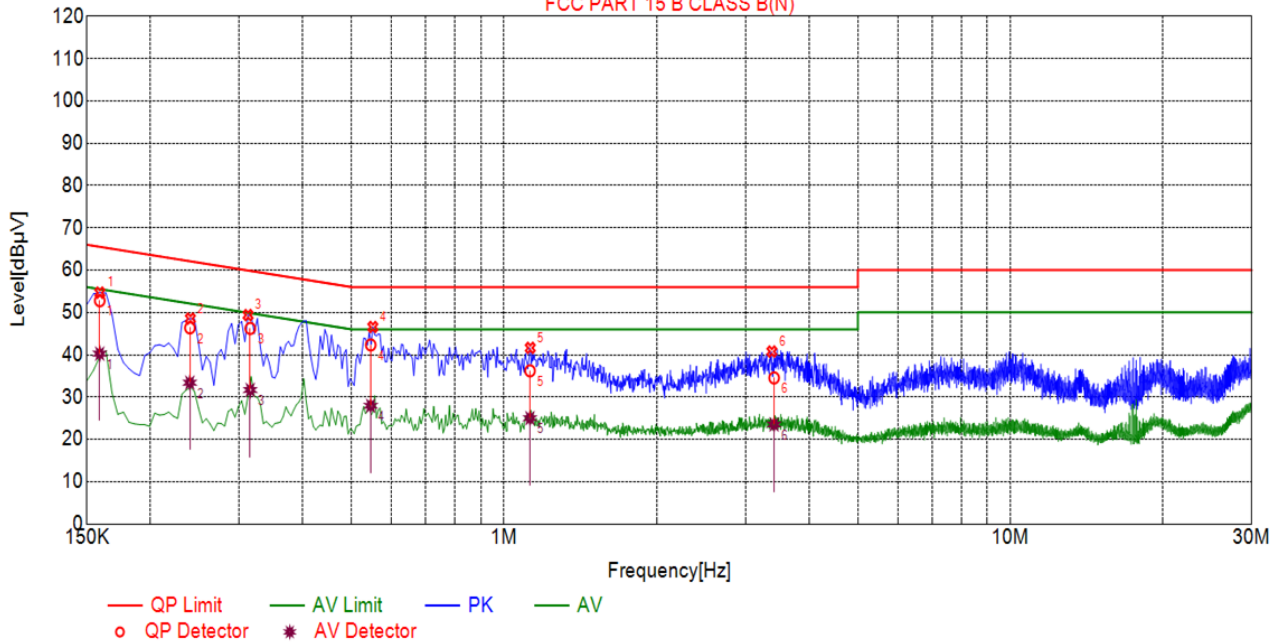

Suspected List						
NO.	Freq. [MHz]	Level [dBµV]	Factor [dB]	Limit [dBµV]	Margin [dB]	Detector
1	0.1590	54.68	10.01	65.52	10.84	PK
2	0.2400	48.55	10.03	62.10	13.55	PK
3	0.3120	49.38	10.05	59.92	10.54	PK
4	0.5505	46.57	10.06	56.00	9.43	PK
5	1.1265	41.63	10.08	56.00	14.37	PK
6	3.3810	40.77	10.24	56.00	15.23	PK

Final Data List								
NO.	Freq. [MHz]	Factor [dB]	QP Value [dBµV]	QP Limit [dBµV]	QP Margin [dB]	AV Value [dBµV]	AV Limit [dBµV]	AV Margin [dB]
1	0.1589	10.01	52.78	65.52	12.74	40.27	55.52	15.25
2	0.2394	10.03	46.37	62.12	15.75	33.40	52.12	18.72
3	0.3151	10.05	46.24	59.83	13.59	31.69	49.83	18.14
4	0.5450	10.05	42.33	56.00	13.67	27.95	46.00	18.05
5	1.1249	10.08	36.20	56.00	19.80	25.01	46.00	20.99
6	3.4148	10.24	34.54	56.00	21.46	23.52	46.00	22.48

RESULT: PASS



8. ANTENNA CONDUCTED POWER FOR RECEIVERS

LIMIT

The antenna conducted power of the receiver as defined in §15.111 shall not exceed the values given in the following tables

Frequency Range	9 KHz to 2GHz
Limit	2.0 nW (-57 dBm)

TEST CONFIGURATION

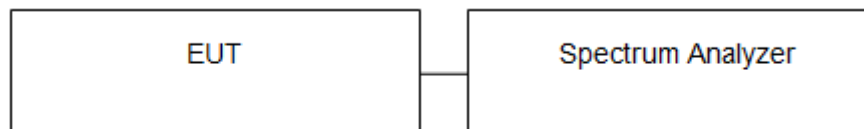

TEST PROCEDURE

1. The receiver antenna terminal connected to to a spectrum analyzer.
2. The test data of condition (mode 1) was reported on the following Data page.



TEST RESULTS (Mode 1)

Conducted Measurement (9 KHz to 150 KHz)

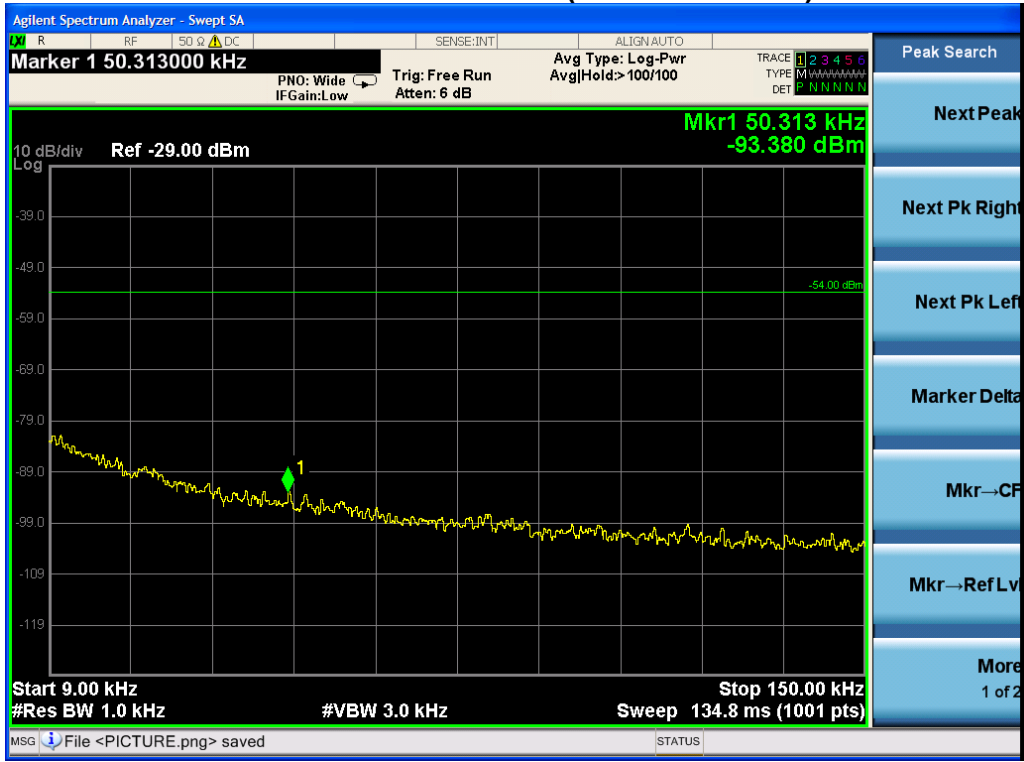

Conducted Measurement (150 KHz to 30MHz)

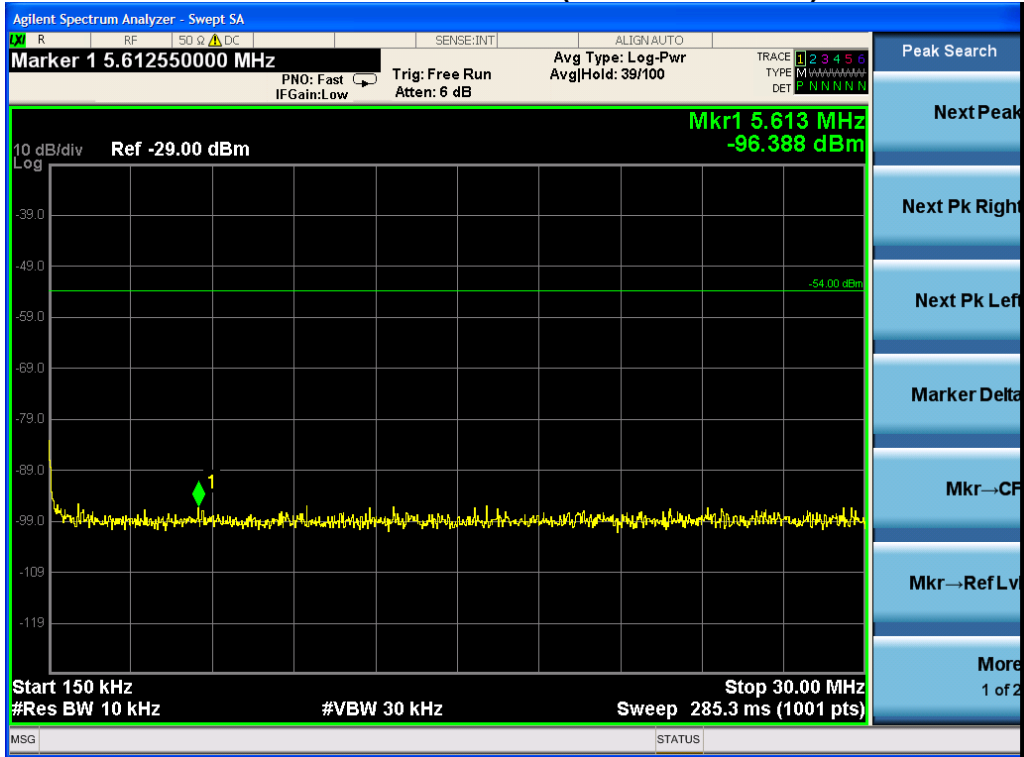



Conducted Measurement (30MHz to 1GHz)

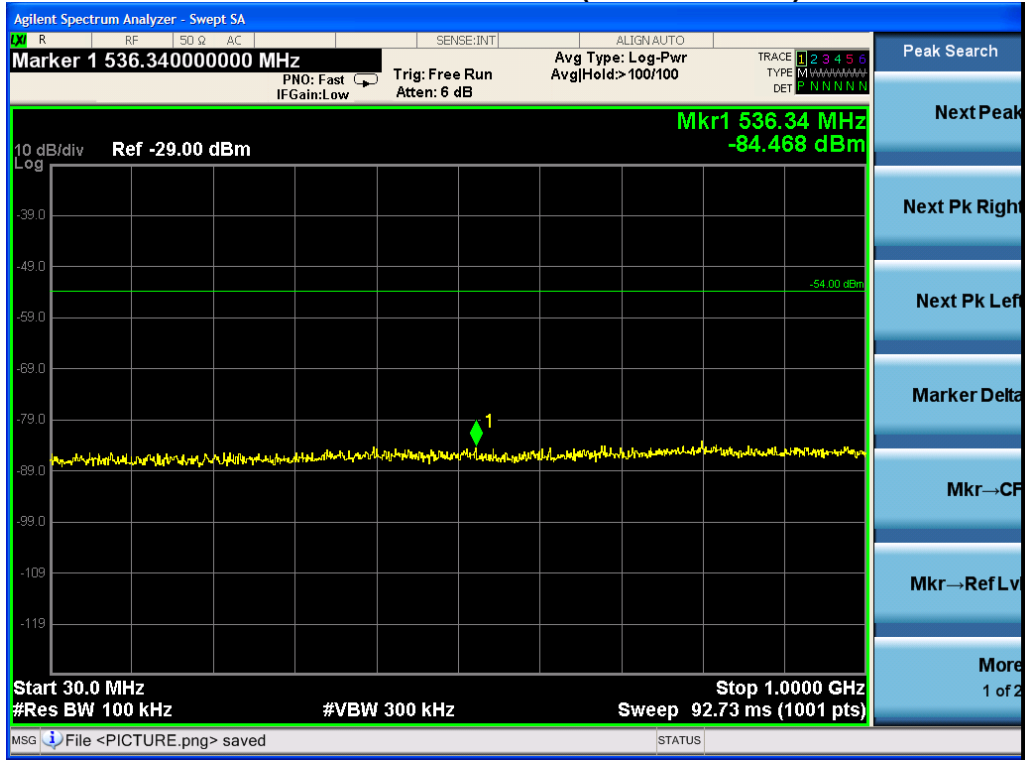

Conducted Measurement (1GHz to 2GHz)

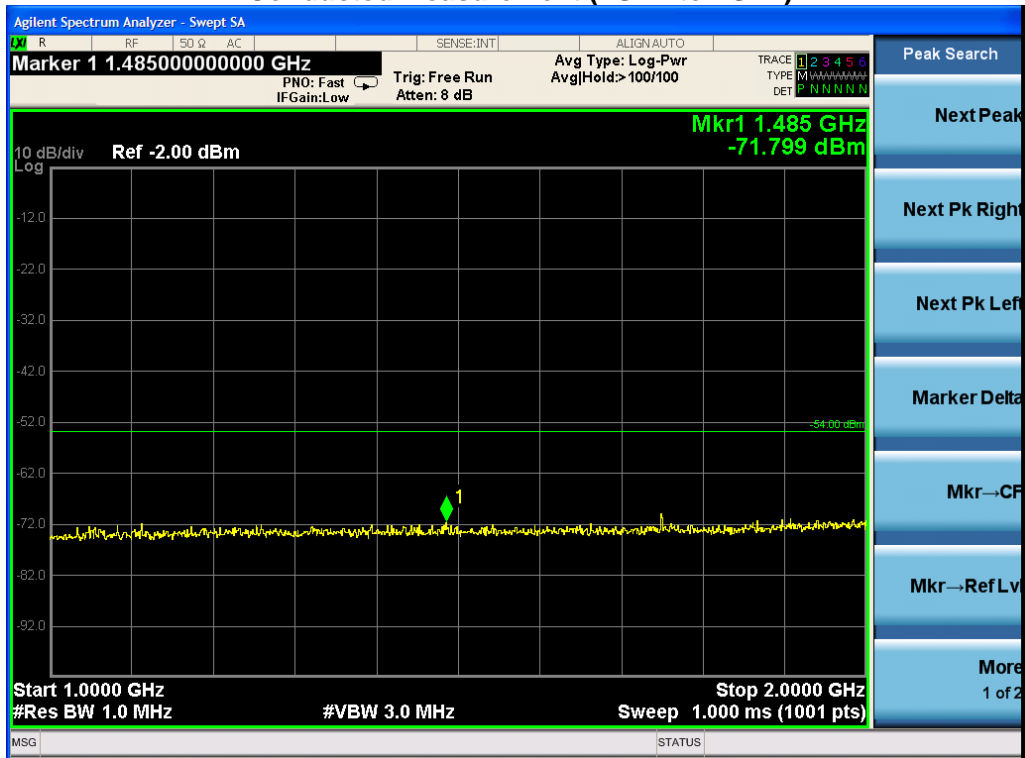

PASS



APPENDIX 1
PHOTOGRAPHS OF TEST SETUP
CONDUCTED EMISSION TEST SETUP



RADIATED TEST SETUP

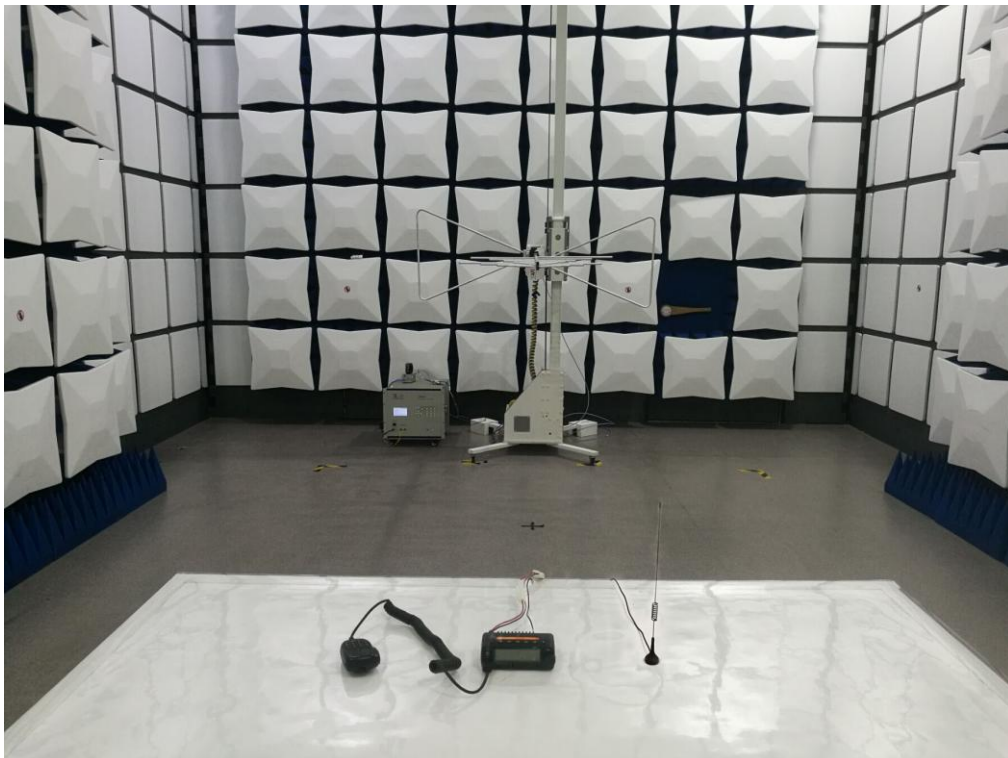



RADIATED ABOVE 1G TEST SETUP

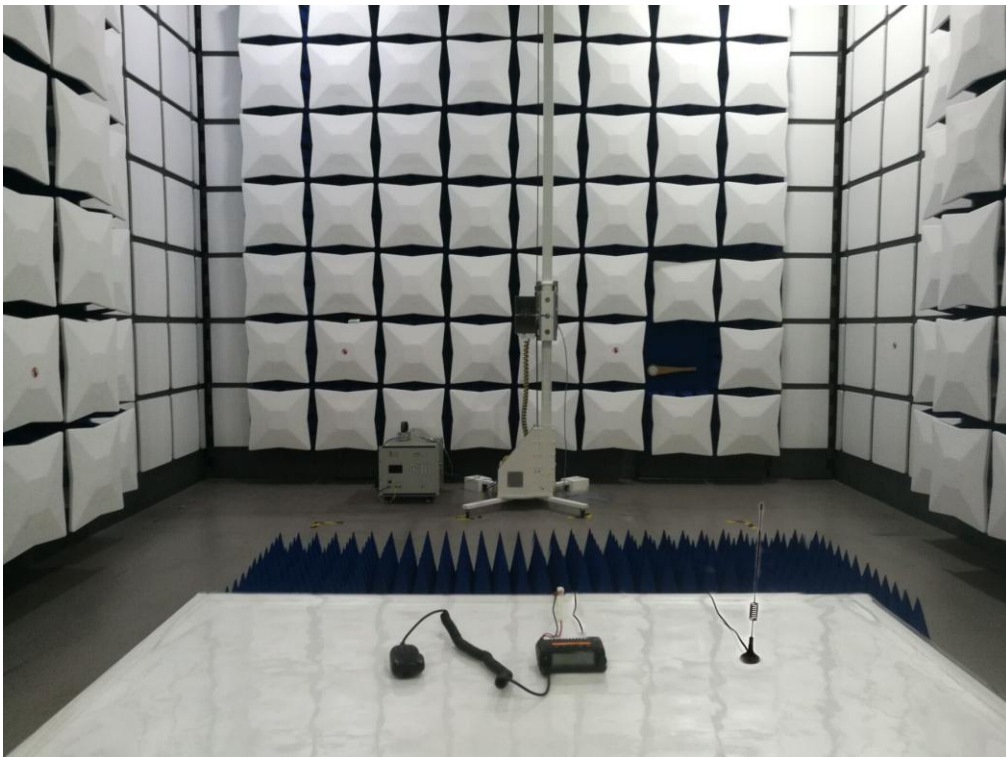

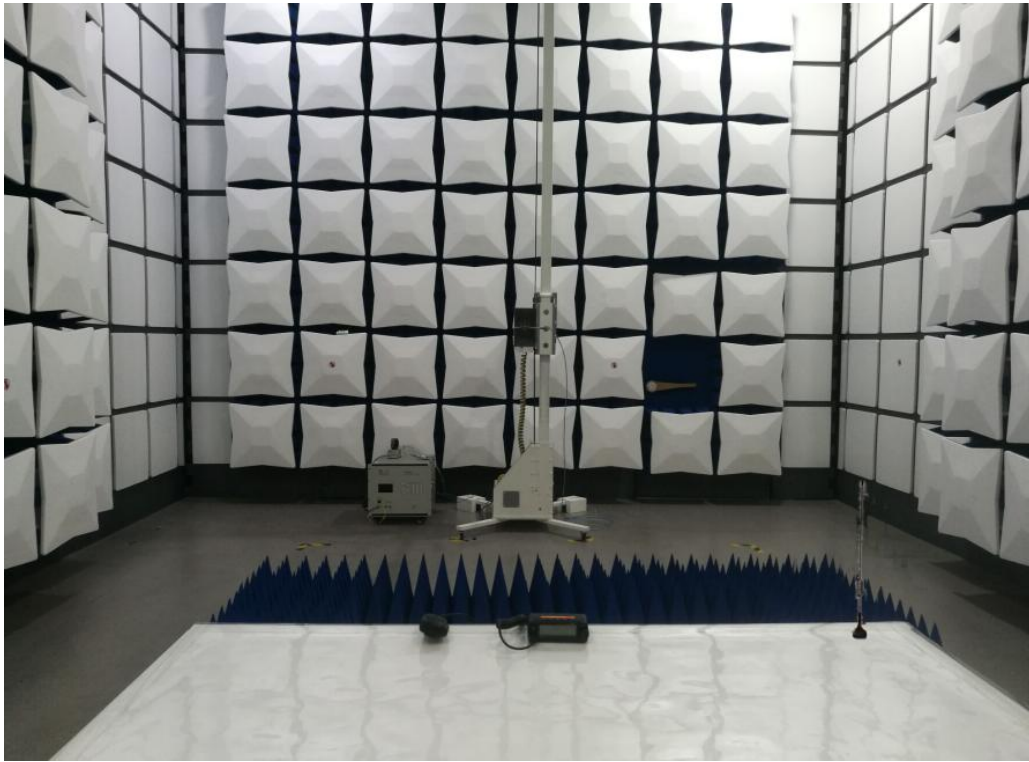



APPENDIX 2 PHOTOGRAPHS OF EUT TOTAL VIEW OF EUT



TOP VIEW OF EUT





BOTTOM VIEW OF EUT



FRONT VIEW OF EUT





BACK VIEW OF EUT



LEFT VIEW OF EUT





RIGHT VIEW OF EUT

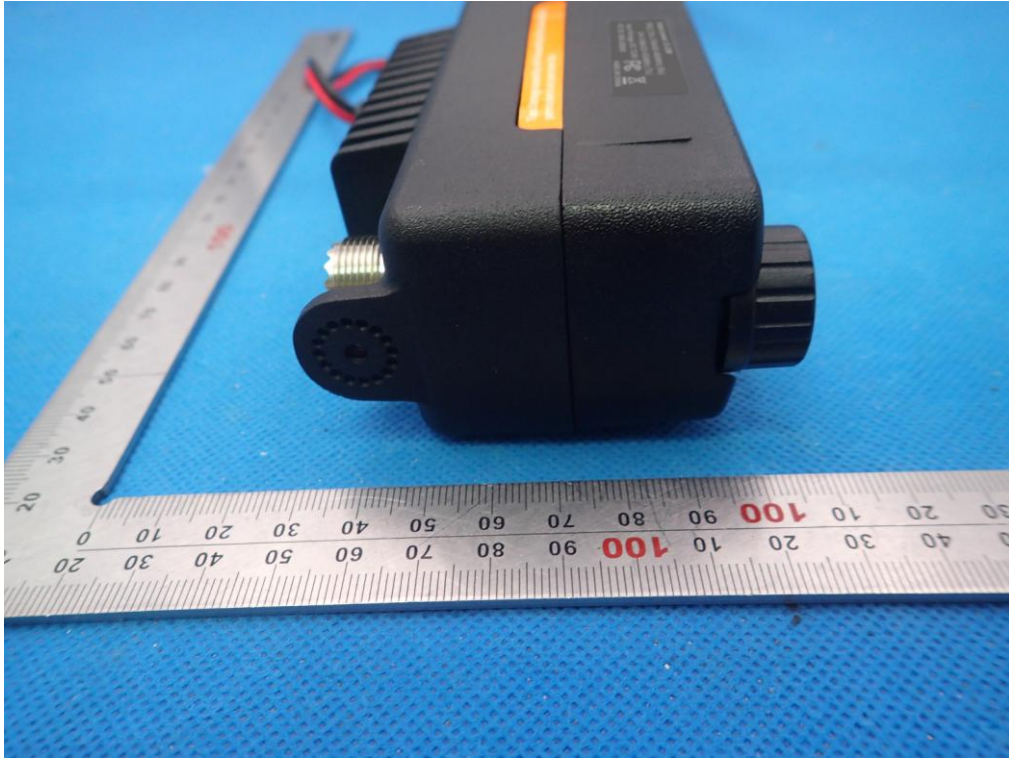

PART 1

OPEN VIEW-1 OF EUT





OPEN VIEW-2 OF EUT

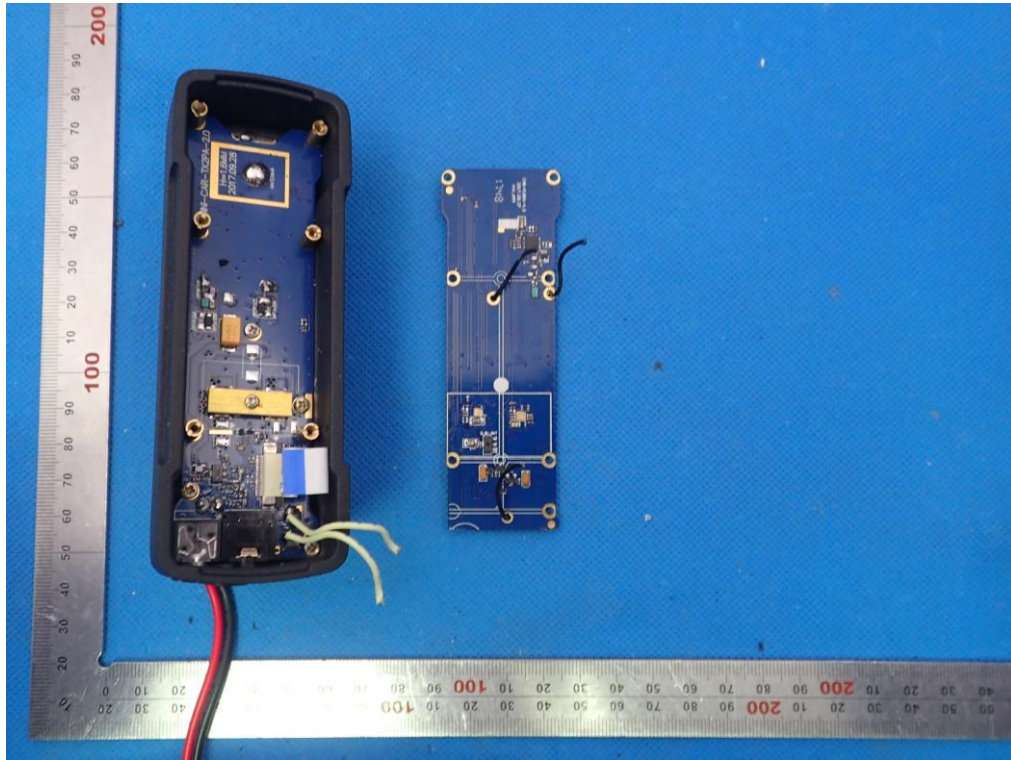

INTERNAL VIEW-1 OF EUT

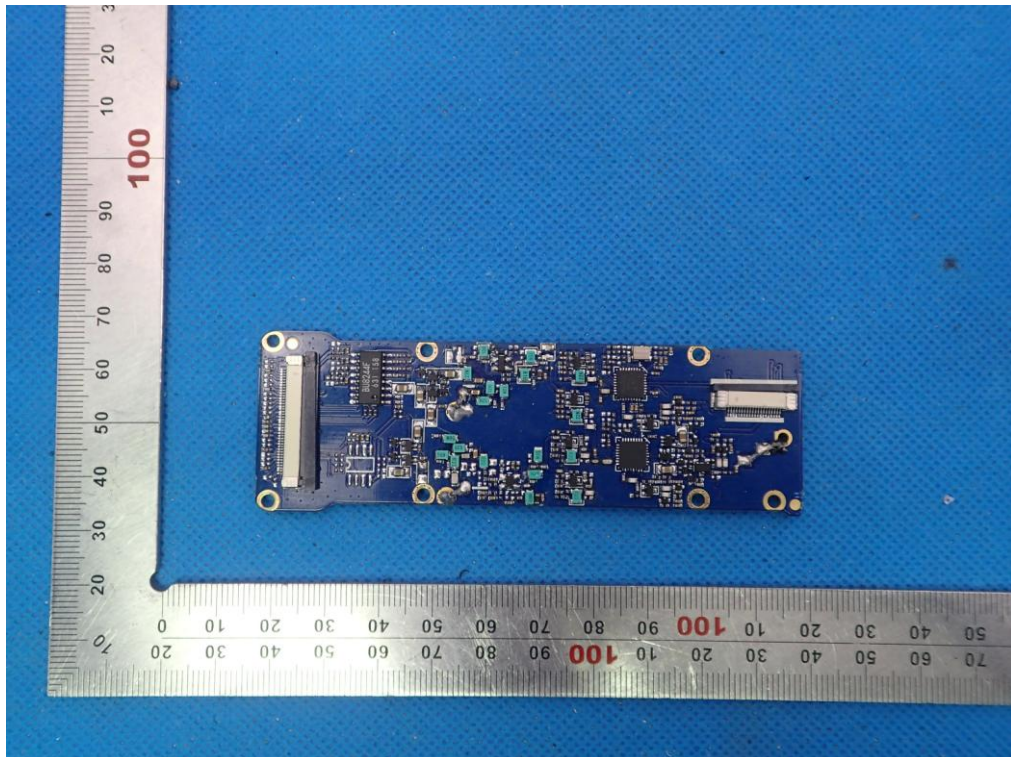



INTERNAL VIEW-2 OF EUT

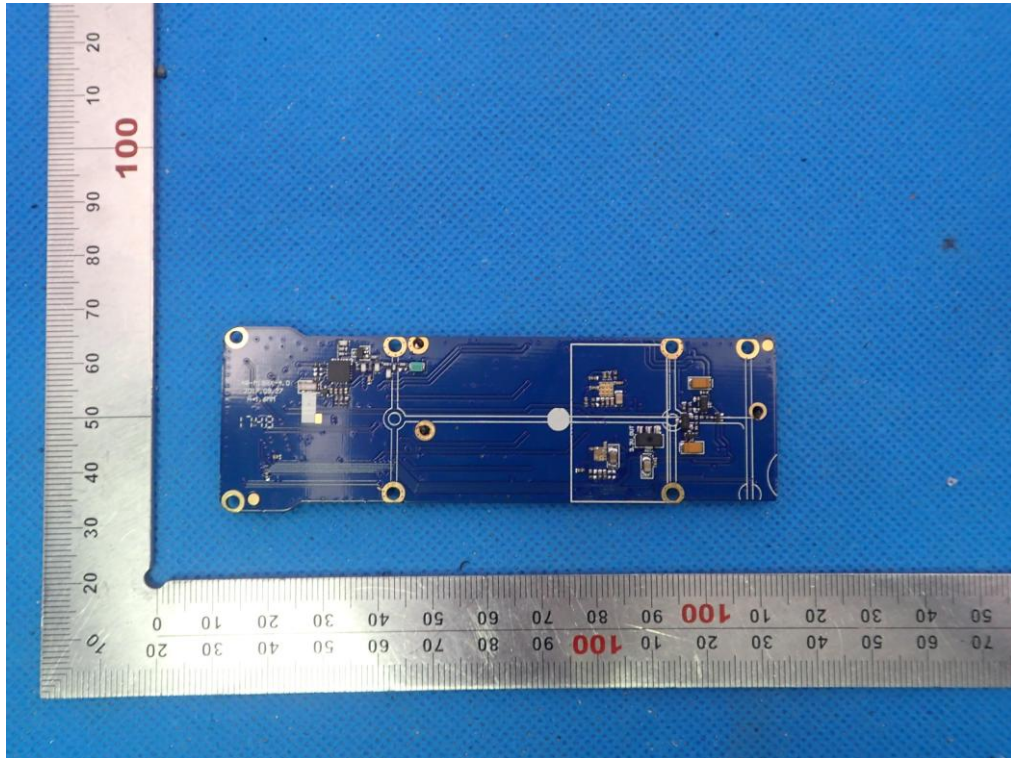

INTERNAL VIEW-3 OF EUT

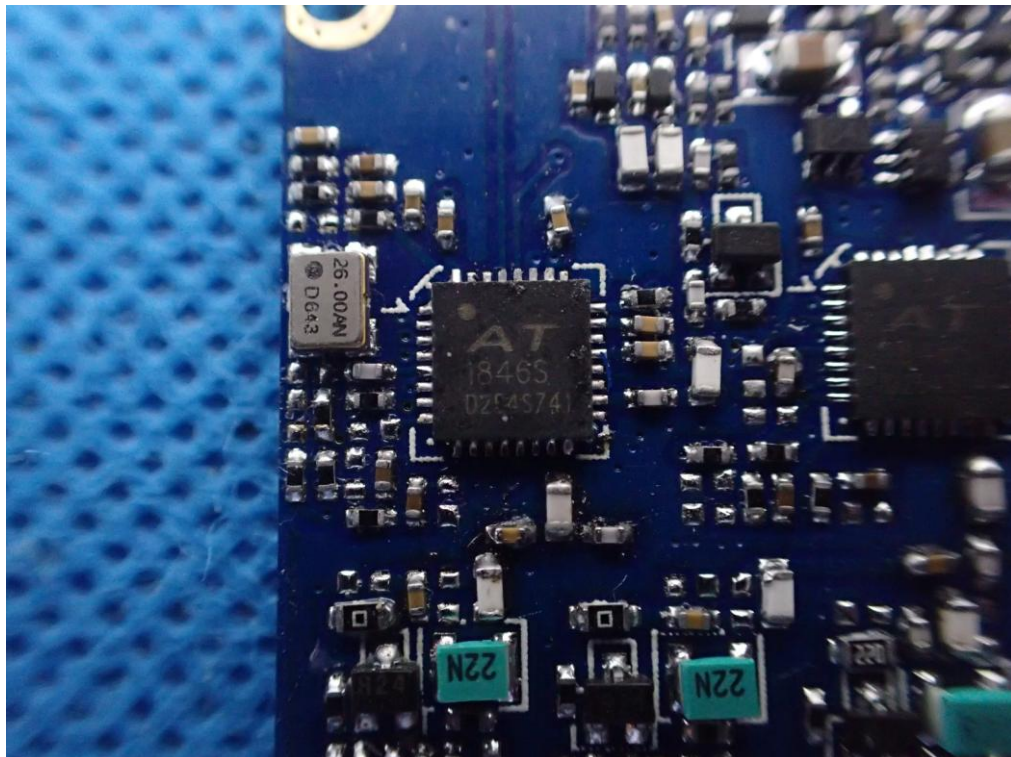



INTERNAL VIEW-3 OF EUT

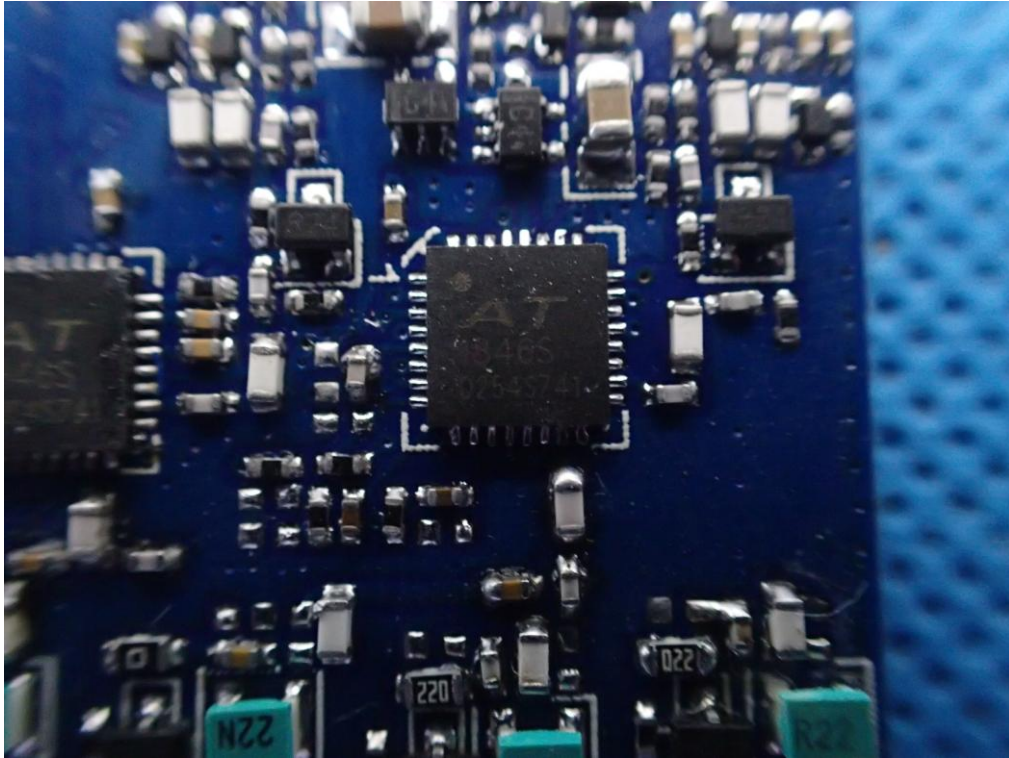

INTERNAL VIEW-4 OF EUT

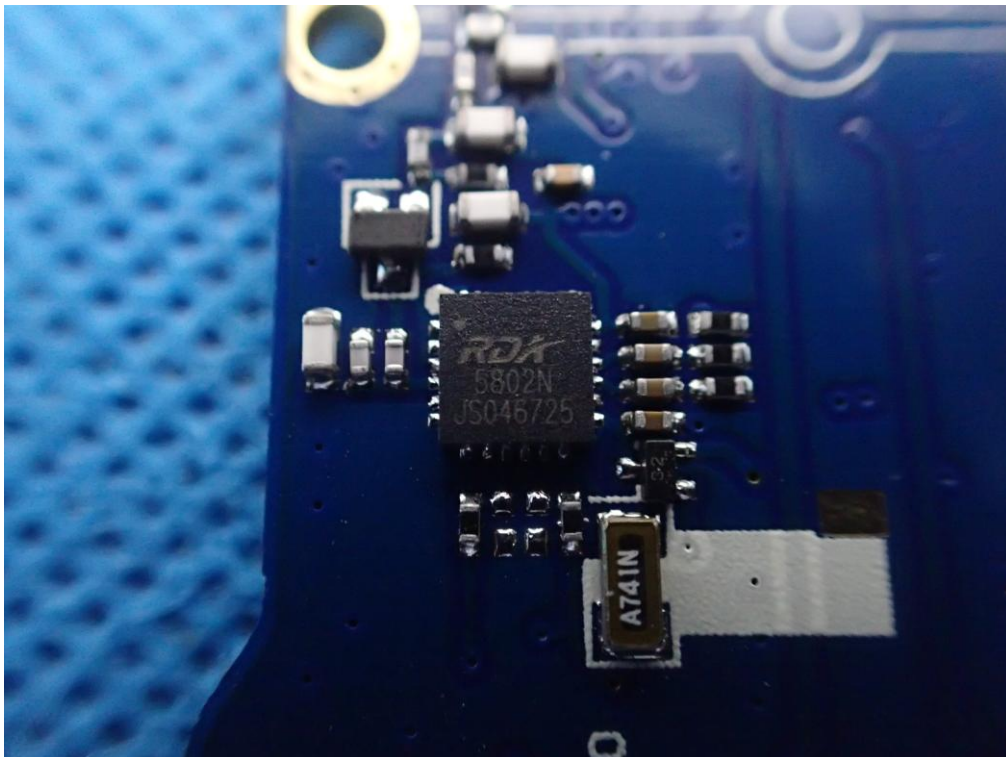



OPEN VIEW-3 OF EUT

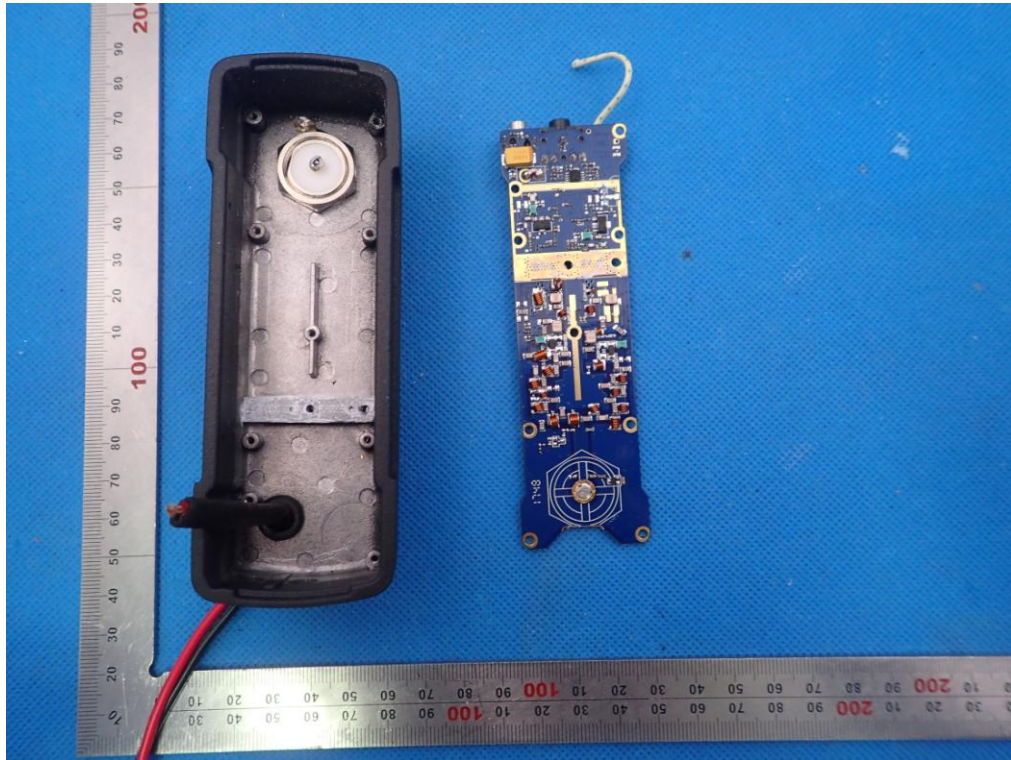

INTERNAL VIEW-1 OF EUT

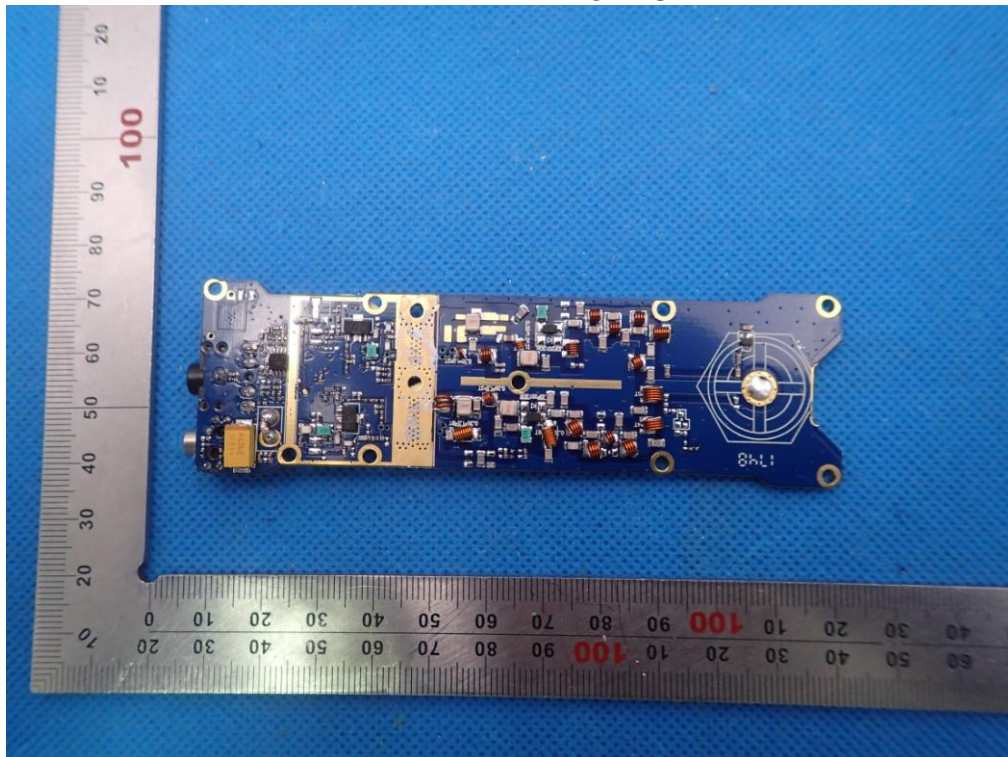



INTERNAL VIEW-2 OF EUT

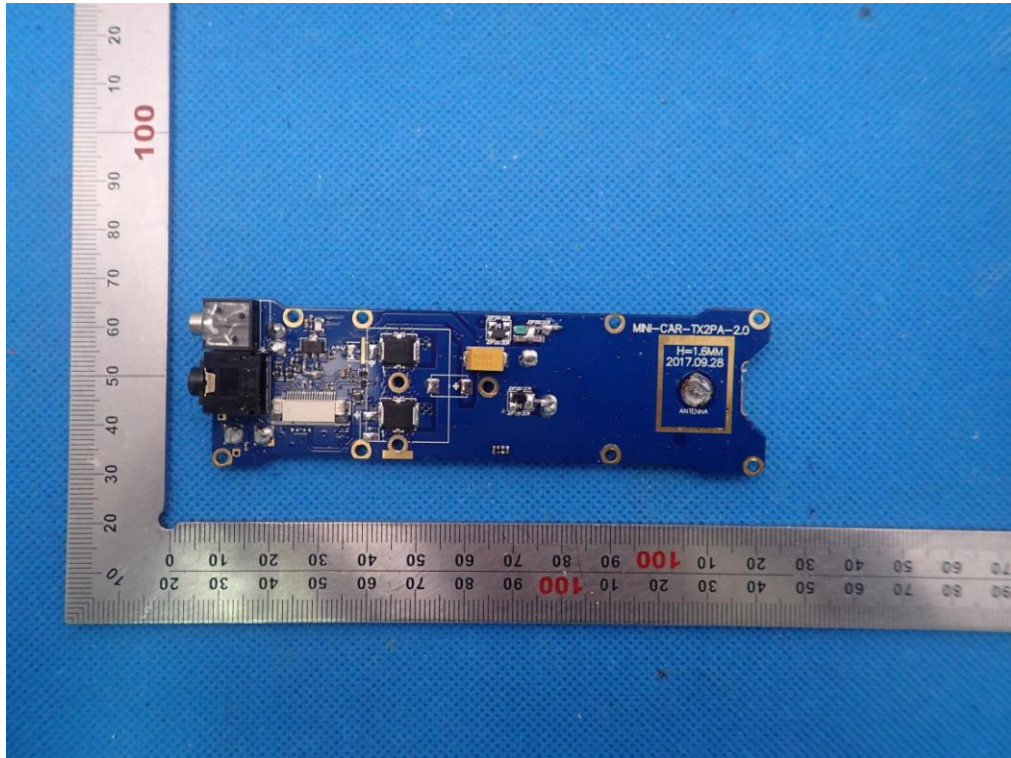

INTERNAL VIEW-3 OF EUT

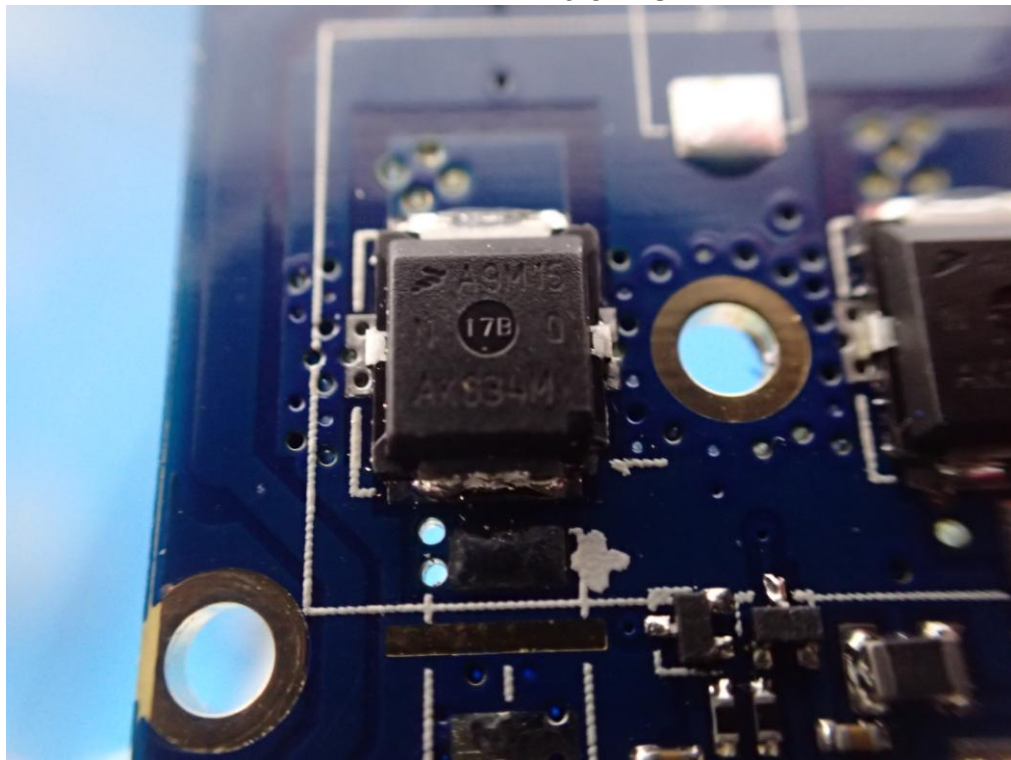



INTERNAL VIEW-4 OF EUT

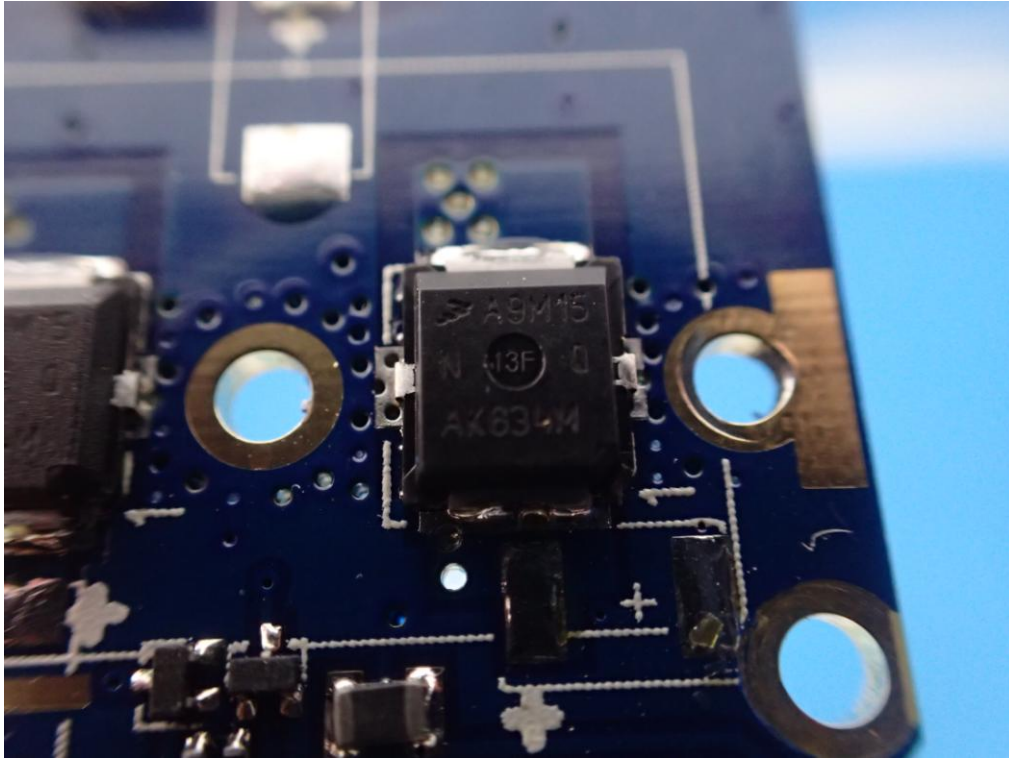

OPEN VIEW-4 OF EUT

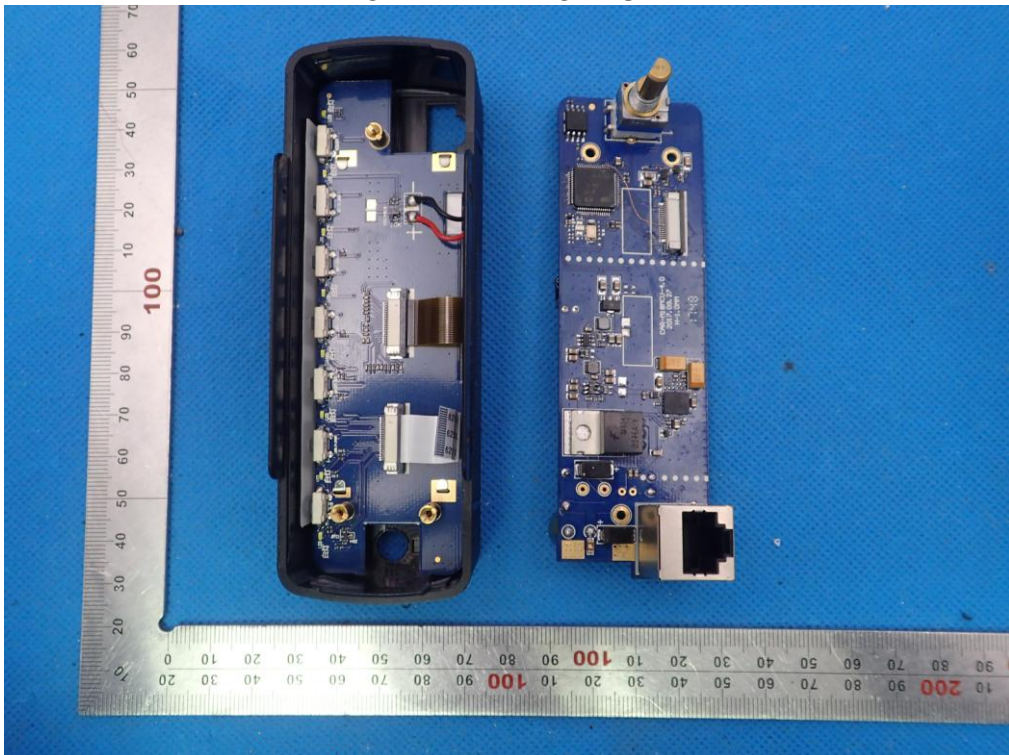



INTERNAL VIEW-1 OF EUT

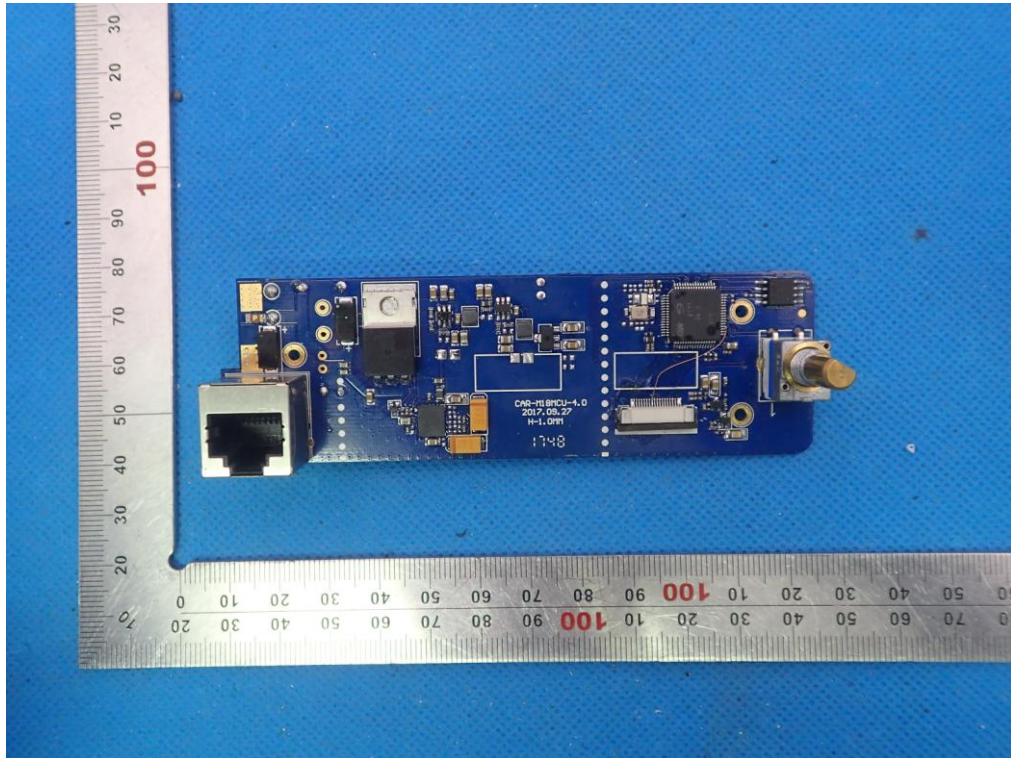

INTERNAL VIEW-2 OF EUT

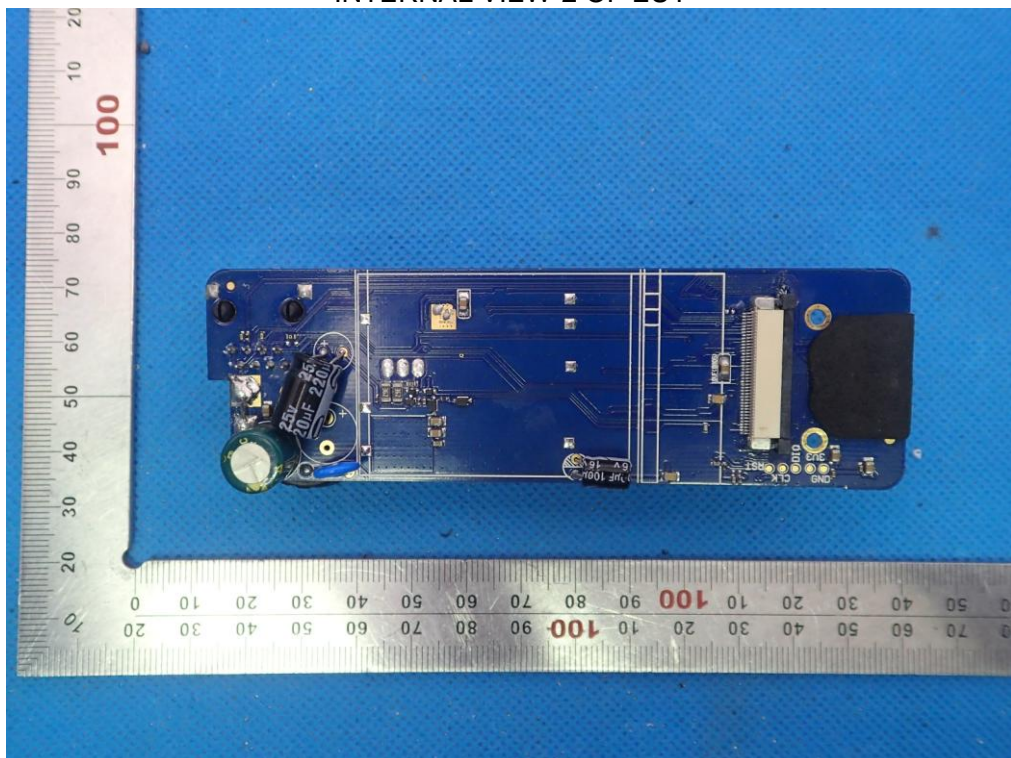



INTERNAL VIEW-3 OF EUT

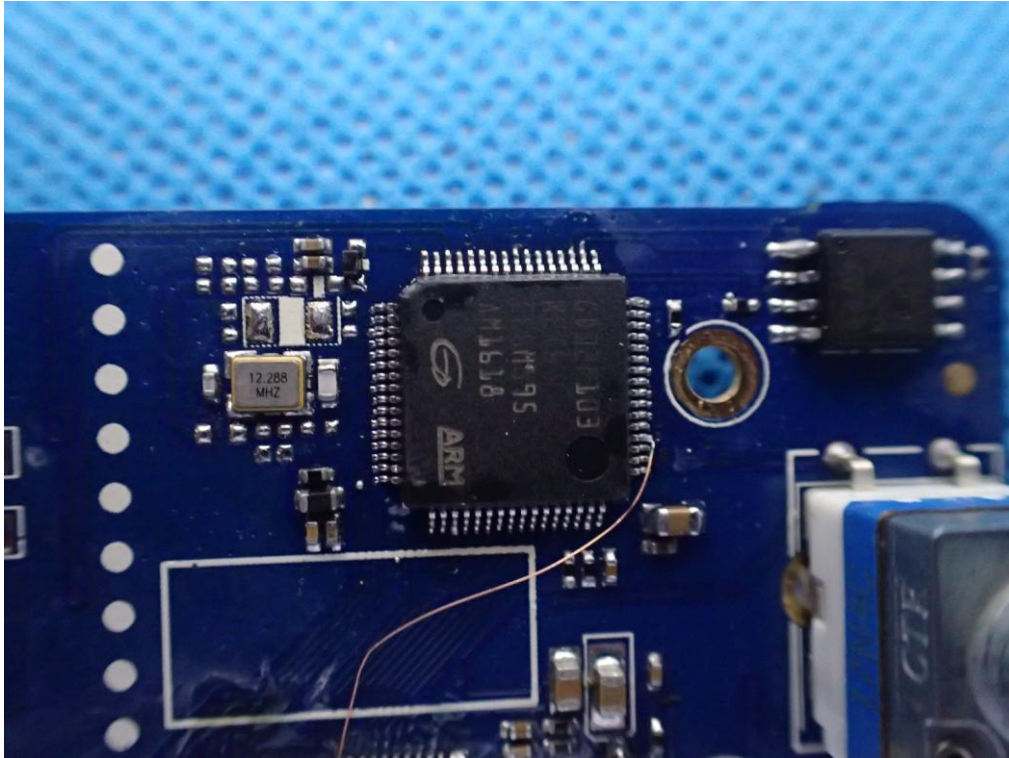

OPEN VIEW-5 OF EUT





INTERNAL VIEW-1 OF EUT

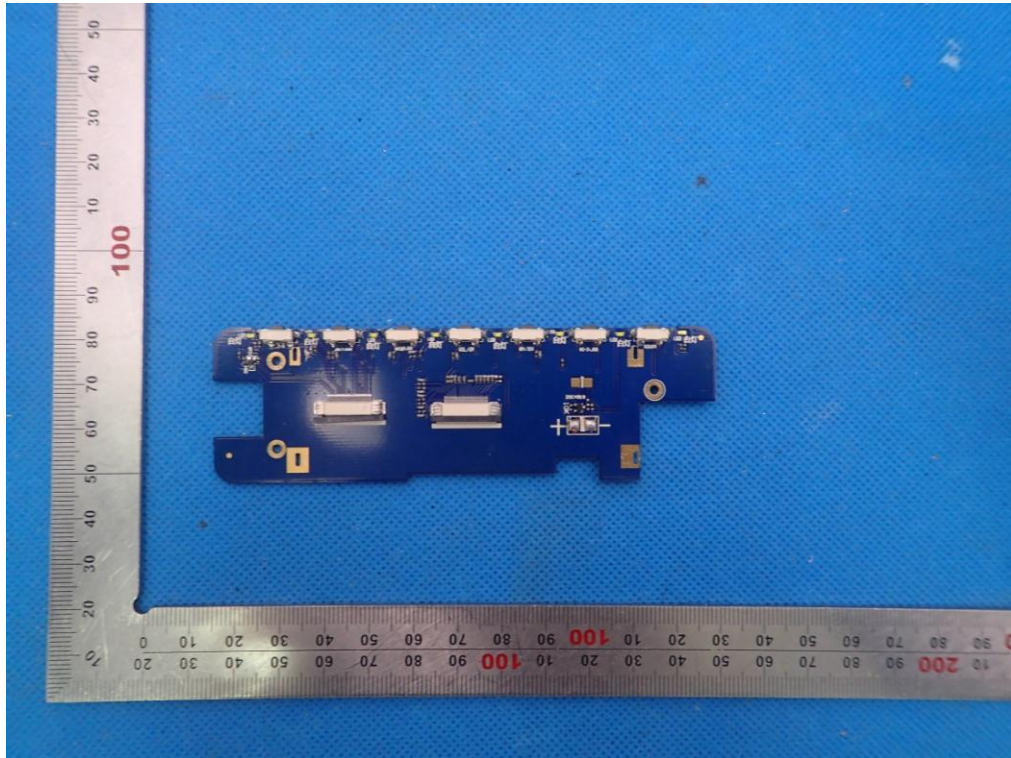

INTERNAL VIEW-2 OF EUT

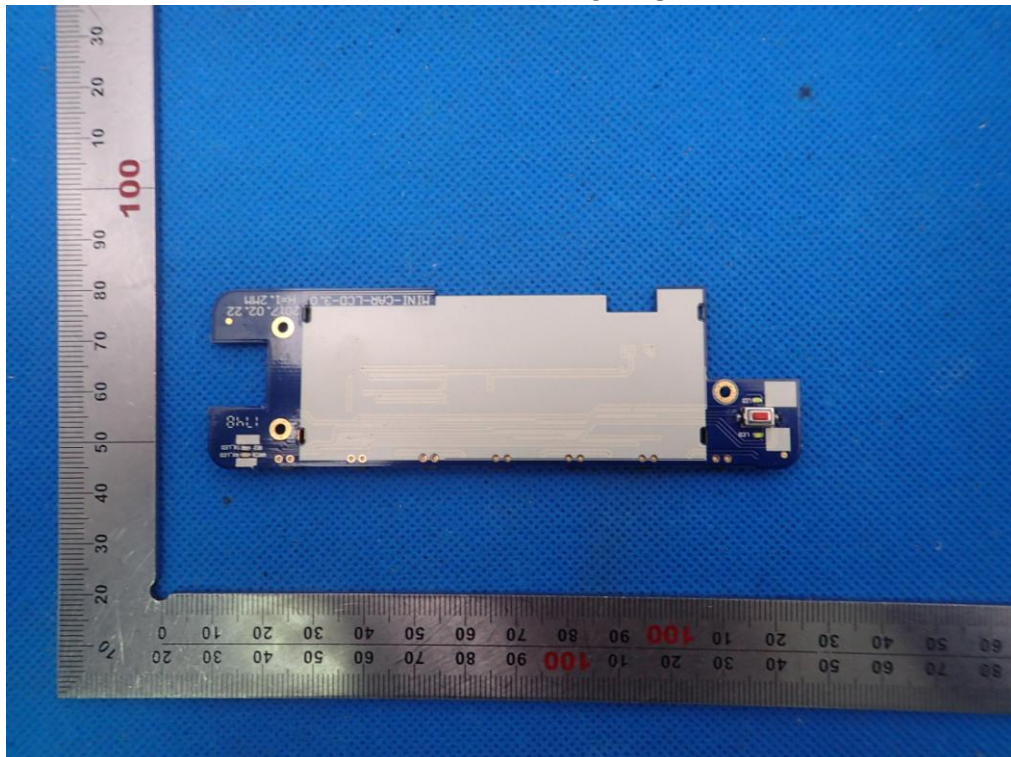



PART 2

TOP VIEW OF EUT



BOTTOM VIEW OF EUT





FRONT VIEW OF EUT



BACK VIEW OF EUT





LEFT VIEW OF EUT



RIGHT VIEW OF EUT





OPEN VIEW-1 OF EUT

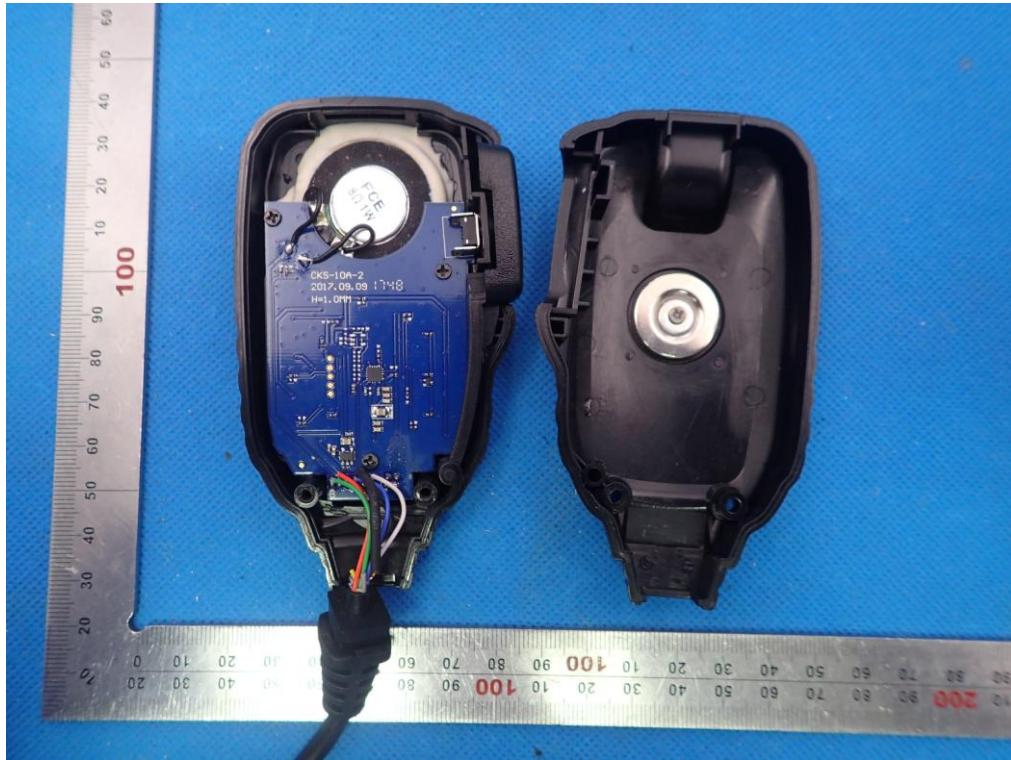

INTERNAL VIEW-1 OF EUT

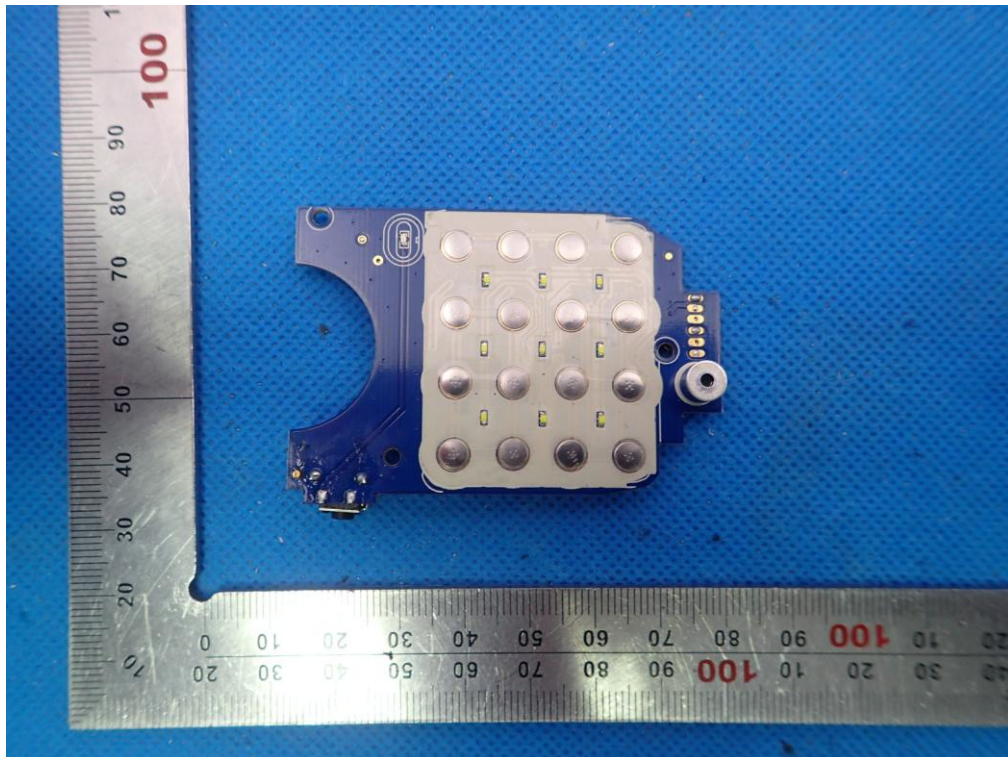



INTERNAL VIEW-2 OF EUT

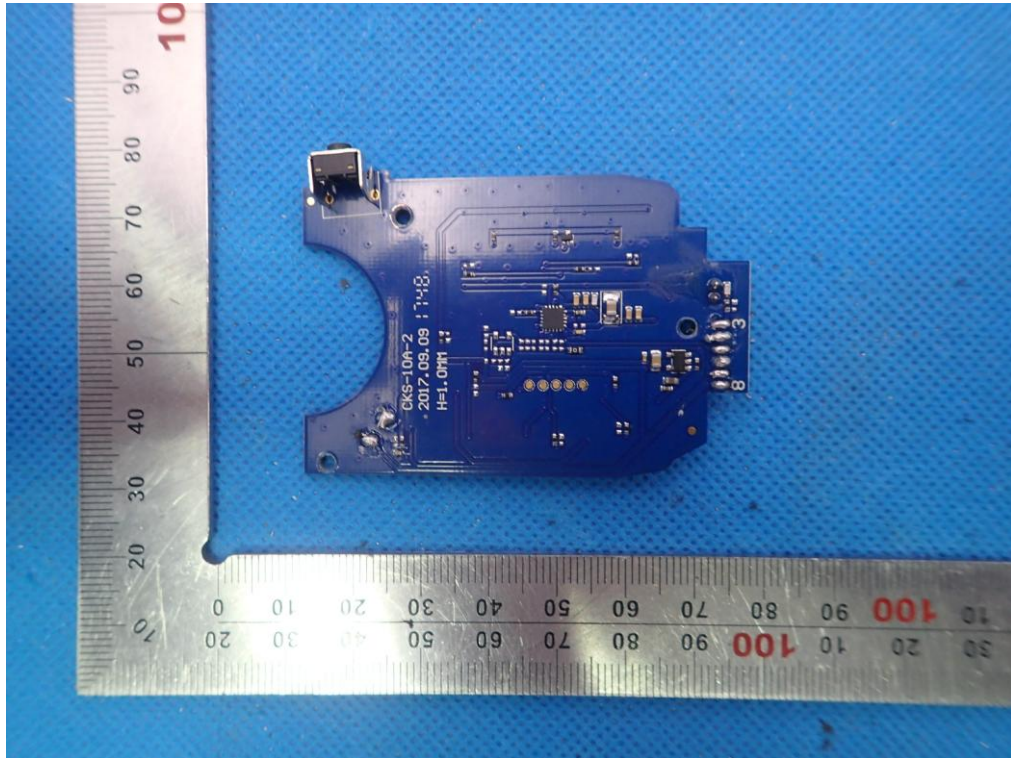

INTERNAL VIEW-3 OF EUT

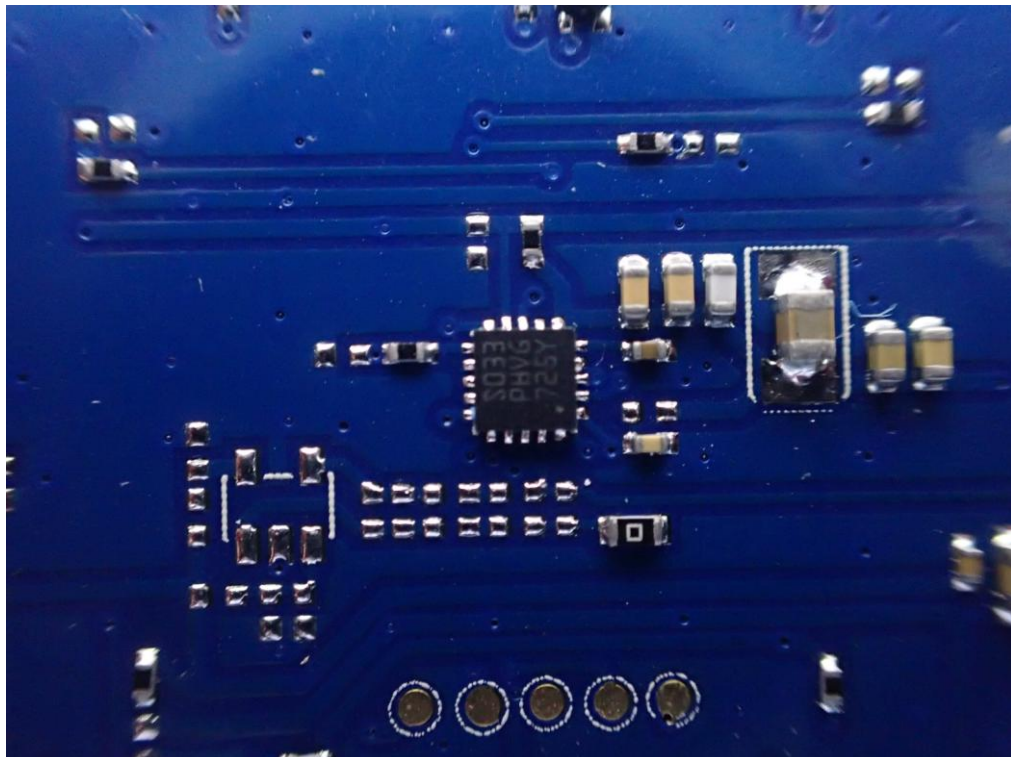

----END OF REPORT----