



OPERATOR'S MANUAL

MANUEL D'UTILISATION

MANUAL DEL OPERADOR

18 VOLT MUSIC, MISTING, AND LIGHT TOWER

TOUR DE BRUMISATION, MUSICAL ET D'ÉCLAIRAGE 18 V

TORRE DE ROCIADO CON

MÚSICA Y LUZ 18 V

MLT0180

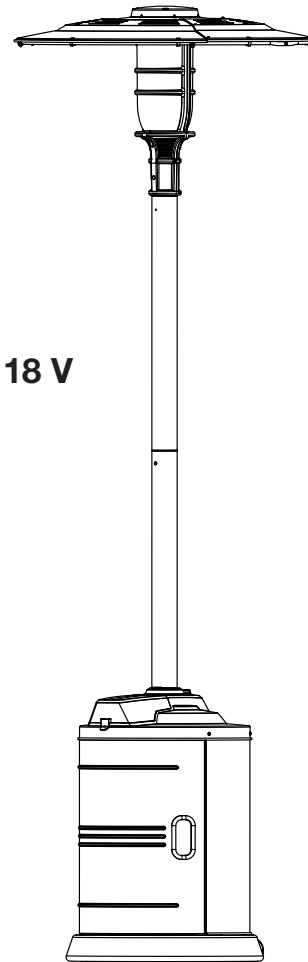

COMPATIBLE WITH RYOBI ONE+ 18 VOLT BATTERIES

COMPATIBLE AVEC ONE+ PILES DE 18 V DE RYOBI

COMPATIBLE CON RYOBI ONE+ BATERÍAS DE 18V

COMPATIBLE WITH ARCTIC COVE 18V BATTERIES

COMPATIBLE AVEC TOUS LES PILES DE 18 V DE ARCTIC COVE

COMPATIBLE CON TODOS LAS BATERÍAS ARCTIC COVE DE 18 V



FCC ID:
VMZMLT0180

TABLE OF CONTENTS

- Important Safety Instructions2-3
- Symbols..... 4
- Assembly.....5-7
- Operation.....7-9
- Maintenance.....9-10
- Accessories 10
- Troubleshooting 10
- Illustrations12-17
- Parts Ordering/Service.....Back page

TABLE DES MATIÈRES

- Instructions importantes
concernant la sécurité.....2-3
- Symboles..... 4
- Assemblage.....5-7
- Utilisation.....7-9
- Entretien9-10
- Accessoires 10
- Dépannage 10
- Illustrations12-17
- Commande de
pièces/dépannage Page arrière

ÍNDICE DE CONTENIDO

- Instrucciones de seguridad
importantes.....2-3
- Símbolos 4
- Armado.....5-7
- Funcionamiento.....7-9
- Mantenimiento.....9-10
- Accesorios..... 11
- Corrección de problemas..... 11
- Ilustraciones12-17
- Pedidos de
repuestos/servicio..... Pág. posterior

WARNING:

To reduce the risk of injury, the user must read and understand the operator's manual before using this product.

AVERTISSEMENT :

Pour réduire les risques de blessures, l'utilisateur doit lire et veiller à bien comprendre le manuel d'utilisation avant d'utiliser ce produit.

ADVERTENCIA:

Para reducir el riesgo de lesiones, el usuario debe leer y comprender el manual del operador antes de usar este producto.

**SAVE THIS MANUAL FOR
FUTURE REFERENCE**

**CONSERVER CE MANUEL
POUR FUTURE RÉFÉRENCE**

**GUARDE ESTE MANUAL
PARA FUTURAS CONSULTAS**

IMPORTANT SAFETY INSTRUCTIONS

WARNING!

READ AND UNDERSTAND ALL INSTRUCTIONS.

Failure to follow all instructions listed below, may result in electric shock, fire and/or serious personal injury.

- **Children can fall into buckets and drown.** Keep children away from buckets with even a small amount of liquid.
- **To reduce the risk of injury,** close supervision is necessary when a product is used near children.
- **Do not allow children to operate this product.** It is not a toy.
- **Exercise caution to avoid slipping or falling.**
- **Use only recommended accessories.** The use of improper accessories may cause risk of injury.
- **Never leave product running unattended. Turn hose faucet completely off and remove battery pack.** Don't leave product until spray comes to a complete stop.
- **Never direct mist or water toward any electrical wiring or devices.**
- **Ensure that all hoses and accessories are properly connected before using the product.**
- **ONLY use clean, cold water.**
- **For outdoor use only.**
- **Do not use this product to spray pesticides, liquid fertilizers, chemicals, or any liquids other than clean water.** Spraying these substances could result in serious injury or illness to the operator or bystanders.
- **Make sure hose and mist tube are located so that they will not be stepped on, tripped over, come in contact with sharp edges or moving parts or otherwise subjected to damage or stress.** This will reduce the risk of accidental falls, which could cause injury, and damage to the hose and mist tube which could prevent the product from working properly.
- **Use caution when positioning the product for use.** Never place the unit near electrical outlets or switches.
- **Check hoses and parts for signs of damage. Replace any damaged hoses or parts.**
- **Verify that all connections are secure before operating the unit.**
- **Use caution when using in windy conditions.** Winds may carry mists into electrical wiring or devices.
- **Do not kink or overbend the hose or mist tube.**
- **Be careful not to spill water when filling water bucket. Ensure all hose connections are secure before using the product.** Spilled water and leaks can result in a slippery surface and create a slip and fall hazard.
- **Do not climb the misting tower to avoid a tip over hazard that can result in serious personal injury.**

- **Do not shake or rock misting tower to avoid a tip over hazard that can result in serious personal injury.**

BATTERY PRODUCT USE AND CARE

- **Use battery operated products only with specifically designated battery pack.** Use of any other batteries may create a risk of fire.
- **Use battery only with charger listed. For use with 18V nickel-cadmium and 18V lithium-ion battery packs,** see tool/appliance/battery pack/charger correlation supplement 987000-432.
- **Dress properly. Do not wear loose clothing or jewelry. Contain long hair. Keep your hair, clothing, and gloves away from moving parts.** Loose clothes, jewelry, or long hair can be caught in moving parts.
- **Avoid accidental starting. Be sure switch is in the off position before inserting battery pack.** Carrying battery products with your finger on the switch or inserting the battery pack into a product with the switch on invites accidents.
- **Do not use battery product if switch does not turn it on or off.** A battery product that cannot be controlled with the switch is dangerous and must be repaired.
- **Disconnect battery pack from product before making any adjustments, changing accessories, or storing the product.** Such preventive safety measures reduce the risk of starting the product accidentally.
- **When battery pack is not in use, keep it away from other metal objects like: paper clips, coins, keys, nails, screws, or other small metal objects that can make a connection from one terminal to another.** Shorting the battery terminals together may cause sparks, burns, or a fire.
- **Keep the product dry, clean and free from oil and grease.** Always use a clean cloth when cleaning. Never use brake fluids, gasoline, petroleum-based products, or any strong solvents to clean your battery product. Following this rule will reduce the risk of loss of control and deterioration of the enclosure plastic.
- **Know your product. Read operator's manual carefully. Learn its applications and limitations, as well as the specific potential hazards related to this battery product.** Following this rule will reduce the risk of electric shock, fire, or serious injury.
- **Battery products do not have to be plugged into an electrical outlet; therefore, they are always in operating condition. Be aware of possible hazards when not using your battery product or when changing accessories.** Following this rule will reduce the risk of electric shock, fire, or serious personal injury.
- **Do not place battery products or their batteries near fire or heat.** This will reduce the risk of explosion and possibly injury.

IMPORTANT SAFETY INSTRUCTIONS



- **Do not crush, drop or damage battery pack. Never use a battery that has been dropped or received a sharp blow.** A damaged battery is subject to explosion. Properly dispose of a dropped or damaged battery immediately.
- **Batteries can explode in the presence of a source of ignition, such as a pilot light.** To reduce the risk of serious personal injury, never use any cordless product in the presence of open flame. An exploded battery can propel debris and chemicals. If exposed, flush with water immediately.
- **Do not charge battery product battery in a damp or wet location.** Following this rule will reduce the risk of electric shock.
- **For best results, batteries should be charged in a location where the temperature is more than 50°F but less than 100°F. Do not store outside or in vehicles.**
- **Under extreme usage or temperature conditions, battery leakage may occur. If liquid comes in contact with your skin, wash immediately with soap and water. If liquid gets into your eyes, flush them with clean water for at least 10 minutes, then seek immediate medical attention.** Following this rule will reduce the risk of serious personal injury.
- **Do not incinerate the product even if it is severely damaged.** The batteries can explode in a fire.
- **Not for use in kitchens.**
- **For general ventilating use only.** Do not use to exhaust hazardous or explosive materials and vapors.
- **To reduce the risk of personal injury and electric shock, the misting tower should not be played with or placed where small children can reach it.**
- **To reduce the risk of electric shock, do not expose to water or rain.**
- **Ensure battery compartment cover is completely closed to prevent water from contacting battery or entering battery port.**

SERVICE









- **Service must be performed only by qualified repair personnel.** Service or maintenance performed by unqualified personnel may result in a risk of injury.
- **When servicing a battery product, use only identical replacement parts. Follow instructions in the Maintenance section of this manual.** Use of unauthorized parts or failure to follow Maintenance Instructions may create a risk of shock or injury.
- **Save these instructions.** Refer to them frequently and use them to instruct others who may use this tool. If you loan someone this tool, loan them these instructions also.

SYMBOLS

The following signal words and meanings are intended to explain the levels of risk associated with this product.

| SYMBOL | SIGNAL | MEANING |
|---|-----------------|--|
|  | DANGER: | Indicates an imminently hazardous situation, which, if not avoided, will result in death or serious injury. |
|  | WARNING: | Indicates a potentially hazardous situation, which, if not avoided, could result in death or serious injury. |
|  | CAUTION: | Indicates a potentially hazardous situation, which, if not avoided, may result in minor or moderate injury. |
| | NOTICE: | (Without Safety Alert Symbol) Indicates important information not related to an injury hazard, such as a situation that may result in property damage. |

Some of the following symbols may be used on this product. Please study them and learn their meaning. Proper interpretation of these symbols will allow you to operate the product better and safer.

| SYMBOL | NAME | DESIGNATION/EXPLANATION |
|---|------------------------------------|--|
|  | Safety Alert | Indicates a potential personal injury hazard. |
|  | Read Operator's Manual | To reduce the risk of injury, user must read and understand operator's manual before using this product. |
|  | Electrocution/Electric Shock | Keep water and mist discharge pointed away from all electrical devices to reduce the risk of electrocution or electric shock. |
|  | Chemical Burns | To reduce the risk of injury or damage, DO NOT USE ACIDS, ALKALINES, BLEACHES, SOLVENTS, FLAMMABLE MATERIAL, OR INDUSTRIAL GRADE SOLUTIONS in this product. |
|  | Slippery Surface | Improper hose connections and/or leaks can result in a slip and fall hazard. |
|  | Do not climb misting tower | Do not climb the misting tower to avoid a tip over hazard that can result in serious personal injury. |
|  | Do not shake or rock misting tower | Do not shake or rock misting tower to avoid a tip over hazard that can result in serious personal injury. |
|  | Wet Conditions Alert | Do not expose to rain or use in damp locations. |
|  | Recycle Symbol | This product uses lithium-ion (Li-ion) batteries. Local, state or federal laws may prohibit disposal of batteries in ordinary trash. Consult your local waste authority for information regarding available recycling and/or disposal options. |

ASSEMBLY

UNPACKING

This product requires assembly.

- Carefully remove the tool and any accessories from the box. All items listed in the **Loose Parts** section must be included at the time of purchase.

WARNING:

Items in this *Assembly* section are not assembled to the product by the manufacturer and require customer installation. Ensure all parts are properly and securely assembled before use. Use of a product that may have been improperly assembled could result in serious personal injury.

- If any parts are damaged or missing, please call 1-877-297-8911 for assistance.

WARNING:

If any parts are damaged or missing do not operate this product until the parts are replaced. Use of this product with damaged or missing parts could result in serious personal injury.

WARNING:

Do not attempt to modify this product or create accessories or attachments not recommended for use with this product. Any such alteration or modification is misuse and could result in a hazardous condition leading to possible serious personal injury.

FEATURES

See page 12.

TOOLS NEEDED

See Figure 1, page 13.

- Phillips screwdriver
- Adjustable wrench

LOOSE PARTS

See Figure 2, page 13.

NOTE: Some parts are packed inside the base assembly.

| | |
|----------------------------------|---|
| A. Hood panel | 3 |
| B. Hood cap | 1 |
| C. Light assembly | 1 |
| D. Upper pole..... | 1 |
| E. Lower pole | 1 |
| F. Base assembly | 1 |
| G. Hardware bag (Not shown)..... | 1 |

HARDWARE

See Figure 3, page 13.

| | |
|--|----|
| AA. Self-tapping Screw (M4 x 16 mm) | 4 |
| BB. Flat Washer, OD10.0xID4.4xT2.0mm | 28 |
| CC. Cap Nut (M4)..... | 12 |
| DD. Machine Screw (M4 x 10 mm) | 16 |
| EE. Large Flat Washer, OD27xID14xT3.1 (for wing nut) | 1 |
| FF. Wing nut..... | 1 |
| GG. Spring clip..... | 9 |
| HH. Misting Hose Assembly | 1 |

ASSEMBLING THE HOOD PANELS AND CAP

See Figures 4 - 5, pages 13 - 14.

Remove the following items from the hardware bag:

- BB** - 24 Flat washers
- CC** - 12 Cap Nuts (M4)
- DD** - 12 Machine Screws (M4 x 10 mm)

NOTE: Hood panel hardware should only be hand-tightened until all panels and the cap are assembled.

HOOD PANEL ASSEMBLY

- Put two of the hood panels together so that one overlaps the other and the three screw holes line up.

NOTE: All three panels are identical.

- Slide washers over two screws.
- Insert the screws through the two outside panel holes.
- Slide a washer over the threaded portion of the screws.
- Thread a nut onto each screw and hand-tighten.
- Repeat on both sides of the remaining panels.

HOOD CAP-TO-PANEL ASSEMBLY

- Place the hood cap on top of the hood assembly so that the six screw holes in the cap align with the remaining six screw holes in the hood assembly.
- Slide washers over six remaining screws.
- Insert the screws through the six holes that connect the panel assembly and cap assembly.
- Slide a washer over the threaded portion of the screws.
- Thread a nut onto each screw and hand-tighten.
- Tighten all 12 fasteners with a screwdriver and wrench.

ASSEMBLY

INSTALLING THE HOOD ASSEMBLY ONTO THE LIGHT ASSEMBLY

See Figure 6, page 14.

Remove the following items from the hardware bag:

- AA** - 4 Self-tapping screws (M4 x 10 mm)
- BB** - 4 Flat Washers

- Place the hood assembly on top of the light assembly.
- Align the four screw holes in the hood cap with the four screw holes in the light assembly.
- Slide flat washers onto each of the four screws. Insert the screws through the hood cap and light assembly. Tighten securely.

INSTALLING THE MISTING HOSE ASSEMBLY INTO THE HOOD

See Figures 7 - 8, pages 14 - 15.

Remove the following items from the hardware bag:

- GG** - 9 Spring clips
- HH** - 1 Misting hose with T-connector

- Insert the open end of the misting hose into the open end of the T-connector as shown. Firmly push the water tube into the connection as far as it will go. Tug on the hose to make sure it cannot be pulled loose from the connector.
- Working from the top side of the hood assembly, push each of the nine spring clips into place, so that the open ends of the clips are on the underside of the hood assembly.

NOTE: Hold each spring clip in place with your thumb while pressing on the misting tube, to prevent pushing the clip back out.

CAUTION:

Be careful to avoid pushing on the edges of the spring clips when installing, which may result in a possible cut hazard.

- Insert the water tube from the light assembly into the T-connector on the misting hose. Make sure it is securely attached.
- Push the misting hose assembly into each of the clips to secure it to the hood.
- Ensure that each of the four misting nozzles on the misting hose assembly are pointing in the direction shown. Twist the nozzles as needed so they are in the correct position.

NOTICE:

Avoid pinching or damaging the water tube and wiring harness during the assembly process, which can damage the product.

ASSEMBLING UPPER POLE TO THE LIGHT ASSEMBLY

See Figure 9, page 15.

Remove the following items from the hardware bag:

- DD** - 4 Machine screws (M4 x 10 mm)

- Pull the water tube and wiring harness from the light assembly all the way through the upper pole.
- Orient and insert upper pole **End A** into the light assembly. Turn the upper pole until the screw holes are aligned.
- Insert a screw into each hole and tighten securely.

NOTE: Take care not to nick wires or tubing.

ASSEMBLING LOWER POLE TO THE BASE ASSEMBLY

See Figures 10 - 11, page 15.

Remove the following items from the hardware bag:

- EE** - Large flat washer
- FF** - Wing nut

- The lower pole is keyed and fits into the base in only one orientation. The tab on the lower pole must face the battery compartment to align with the rectangular slot and fit correctly into the base.
- Insert the lower pole into the base assembly as shown. When the pole is properly aligned and fully inserted, the tab should fit snugly into the rectangular slot.
- Secure the lower pole to the base assembly with a flat washer and wing nut. Do not overtighten.

FILLING THE BASE WITH SAND (NOT INCLUDED)

See Figure 12, page 15.

Adding play sand to the compartment in the base increases the stability of the assembled misting tower.

NOTE: Play sand is not included.

- Unscrew the plastic cap in the bottom of the base and fill with play sand.
- Replace and securely tighten the plastic cap.

The base must sit on a flat, level surface before installing the light assembly and upper pole to the lower pole and base assembly.

ASSEMBLY

INSTALLING THE LIGHT ASSEMBLY AND UPPER POLE TO THE LOWER POLE AND BASE ASSEMBLY

See Figures 13 - 15, page 16.

Remove the following items from the hardware bag:

DD - 2 Machine screws

NOTE: Make sure the full lengths of the wiring harness and water pickup tube can be pulled through the lower pole and base assembly and that none of the tubes or wiring are kinked before further installation.

- Position the assembled upper section over the lower pole and base assembly.
- Feed the wiring harness and water pickup tube into the lower pole.

- Align the screw holes on each side of the upper and lower poles. Insert the upper pole into the lower pole.
- Insert a screw into each hole and tighten securely.
NOTE: The upper pole telescopes into the lower pole for assembly.
- Pull the wiring harness and water pickup tube through the rectangular opening in the base assembly.
- Orient and connect the wiring harness from the pole with the wiring harness inside the base.
- Connect the coupler to the water tube in the base assembly by pushing it onto the tube as far as it will go.
- Pull on the water tube to be sure it is fully inserted and the coupler is securely in place.

OPERATION

WARNING:

Do not allow familiarity with products to make you careless. Remember that a careless fraction of a second is sufficient to inflict serious injury.

WARNING:

Keep water and mist discharge pointed away from all electrical devices to reduce the risk of electrocution or electric shock.

WARNING:

Ensure all hose connections are secure before using this product. Spilled water and leaks can result in a slippery surface and create a slip and fall hazard.

WARNING:

Do not use any attachments or accessories not recommended by the manufacturer of this product. The use of attachments or accessories not recommended can result in serious personal injury.

WARNING:

Always remove battery pack from the product when you are assembling parts, making adjustments, cleaning, or when not in use. Removing battery pack will prevent accidental starting that could cause serious personal injury.

APPLICATIONS

You may use this product for the following purposes:

- Connect to a 5-gallon bucket filled with water for outdoor cooling
- Listening to music via BLUETOOTH® connection and speaker in the unit
- LED area lighting

WARNING:

Do not use this product to spray pesticides, liquid fertilizers, chemicals, or any liquids other than clean water. Spraying these substances could result in serious injury or illness to the operator or bystanders.

WARNING:

Never climb, shake, or rock misting tower. Failure to follow these instructions can cause the misting tower to tip over and result in death or serious personal injury.

OPERATION

FILLING THE WATER BUCKET

(NOT INCLUDED)

See Figure 16, page 16.

WARNING:

Children can fall into buckets and drown. Keep children away from buckets with even a small amount of liquid.

- The base is designed to hold a 5-gallon contractor-type bucket.

NOTE: Clean the bucket with soap and water before each use. Using a contaminated or dirty bucket can cause clogging of the pickup tube.

- Move the misting tower to the location where it will be used before installing and filling the bucket.
- Center the bucket inside the base.
- The filter end of the water pickup tube should go straight down into the bucket.
- Add **ONLY** clean, cold water into the bucket.
- Insert a garden hose into the bucket and add water until the water level is just below the handle. Do not overfill.

WARNING:

Always route hoses away from traffic areas to prevent a tripping hazard.

WARNING:

When filling, moving, or emptying bucket, be careful not to spill water and do not overfill bucket. Spilled water can result in a slippery surface, create a slip and fall hazard, and cause property damage.

- Close the door of the base before operation.

INSTALLING/REMOVING THE BATTERY PACK

See Figure 17, page 16.

- Press the tab to open the battery compartment latch.
- Insert the battery pack into the battery port.
- Make sure the latches on each side of the battery pack snap into place and the battery pack is secured before beginning operation.
- Close the battery compartment cover and press until it snaps shut and is securely closed.

- To remove the battery pack, open the battery compartment cover and depress the latches on each side of the battery pack.
- Remove the battery pack and securely close the compartment cover.

NOTICE:

Always close the battery compartment cover after installing or removing the battery pack. Water entering the compartment can cause damage to the product.

CONTROL PANEL

See Figure 18, page 16.

- The BLUETOOTH® icon button on the left side of the panel controls the speaker. Press the button to turn the speaker **ON** or **OFF**.
- The water droplet button on the right side of the panel controls the misting spray. Press the button to turn the mist **ON** or **OFF**.
- The knob in the center of the control panel turns on the LED lighting feature. Turn the knob to the right to increase the brightness of the light. Turn the knob to the left to decrease brightness.

When the buttons for the mister and BLUETOOTH® speaker are pressed, they light up to indicate those features are active.

USING A BLUETOOTH® ENABLED DEVICE (NOT INCLUDED)

The BLUETOOTH® feature lets you connect to the speaker on the tower using a smartphone, laptop computer, tablet, or BLUETOOTH® enabled MP3 player.

No password or PIN is required for connection.

- Press the BLUETOOTH® icon button on the control panel. The icon will illuminate to show it has been activated.
- Three tones will sound to indicate the tower is ready to pair with the device you wish to use.
NOTE: The tower will connect with only one device at a time.
- Select “Arctic Cove Misting Tower” from the list of available devices in the BLUETOOTH® menu of your controlling device.
- Three beeps will sound to indicate the tower and your device are paired.
- Music selections and volume are controlled using the device you have paired with the tower.
- The next time you wish to connect your device to the tower, it will pair with your device automatically.

OPERATION

MOVING THE MUSIC, MISTING, AND LIGHT TOWER

See Figure 19, page 17.

WARNING:

Securely hold misting tower when moving, do not over tilt the unit, and only place on a flat, level surface. Improper movement or placement of the misting tower may cause it to tip over and result in death or serious personal injury.

Wheels are installed on one side of the base assembly for ease in relocating the misting tower.

Always move the unit to a level surface and make sure it is in a stable position. Never place the tower in any position other than upright.

To move the tower:

- Remove the water bucket and securely close the door of the base assembly.
- Remove the battery pack and close the battery compartment cover.
- Grasp the center pole and carefully tilt the tower toward you slightly until it balances on the wheels, then roll the tower to the desired position. Do not tilt forward or sideways when moving.
- When the tower is in the desired location, carefully set the tower upright.

MAINTENANCE

WARNING:

When servicing, use only identical replacement parts. Use of any other parts could create a hazard or cause product damage.

GENERAL MAINTENANCE

Avoid using solvents when cleaning plastic parts. Most plastics are susceptible to damage from various types of commercial solvents and may be damaged by their use. Use clean cloths to remove dirt, dust, oil, grease, etc.

WARNING:

Do not at any time let brake fluids, gasoline, petroleum-based products, penetrating oils, etc., come in contact with plastic parts. Chemicals can damage, weaken or destroy plastic which could result in serious personal injury.

WARNING:

With the battery pack removed from the product, always clean and thoroughly dry out all parts of the misting hose assembly, and water tubes when not in use to prevent the possible formation of bacteria or mold. Spraying mist that contains bacteria or mold can result in serious personal injury or illness.

NOZZLE MAINTENANCE

See Figure 20, page 17.

WARNING:

Ensure all nozzle maintenance is properly performed to prevent leaks. Leaks can result in a slippery surface, create a slip and fall hazard, or cause property damage.

Irregular mist patterns or leakage may be the result of a clogged or dirty nozzle.

To clean nozzles:

WARNING:

Always wear eye protection with side shields marked to comply with ANSI Z87.1 when performing these maintenance steps. Failure to do so could result in objects being thrown into your eyes, resulting in possible serious injury.

- Remove the battery pack.
- Remove the brass nozzles.
- Soak nozzles in Arctic Cove nozzle cleaner (not included, MACC008) to loosen foreign materials clogging or restricting the nozzle.
- Using a garden hose, flush debris out of nozzle by back flushing (running the water through the nozzle backwards or from the outside to the inside).
- Reconnect the nozzles.

MAINTENANCE

FILTER MAINTENANCE

See Figure 21, page 17.

Periodically check the filter at the end of the water tube for debris and to make sure it is in good condition. Remove the plastic filter cover and rinse or replace the filter, then snap the cover back together.

DISCONNECTING THE WATER TUBE FROM THE T-CONNECTOR

See Figure 22, page 17.

For maintenance, replacement, or cleaning, it may be necessary to disconnect the water tube from the T-connector.

- Remove the battery pack.
- Remove the blue ring from the T-connector.
- Push the collar toward the T-connector while pulling the water tube in the opposite direction to release the tube.
- To replace the tube, see **Installing the Misting Hose Assembly into the Hood** in the **Assembly** section of this manual.
- When the water tube is secured in the T-connector, replace the blue ring.

ACCESSORIES

To order these accessories, call 1-877-297-8911.

- Brass Misting Nozzle (5pk) Model No. MAC080
- Nozzle Cleaner..... Model No. MACC008

WARNING:

Current attachments and accessories available for use with this product are listed above. Do not use any attachments or accessories not recommended by the manufacturer of this product. The use of attachments or accessories not recommended can result in serious personal injury.

TROUBLESHOOTING

| PROBLEM | POSSIBLE CAUSE | SOLUTION |
|--|---|---|
| Leak at nozzle, threaded hole, or connection | Nozzles clogged or dirty. Misting tube or water hose connected improperly. | Clean nozzles. Reconnect misting tube or water hose. |

NOTE: ILLUSTRATIONS BEGIN ON PAGE 12 AFTER FRENCH AND SPANISH LANGUAGE SECTIONS.

**This product has a four-year Limited Warranty.
For Warranty details go to www.arcticcove.com**

BLUETOOTH® LICENSE STATEMENT

The BLUETOOTH® word mark and logos are registered trademarks owned by Bluetooth SIG, Inc. and any use of such marks by TECHTRONIC POWER TOOLS TECHNOLOGY LIMITED is under license. Other trademarks and trade names are those of their respective owners.

FCC COMPLIANCE

WARNING:

Changes or modifications to this unit not expressly approved by the party responsible for compliance could void the user's authority to operate the equipment.

NOTE: This equipment has been tested and found to comply with the limits for a Class B digital device, pursuant to Part 15 of the FCC Rules. This Class B digital apparatus complies with Canadian ICES-003. These limits are designed to provide reasonable protection against harmful interference in a residential installation. This equipment generates, uses and can radiate radio frequency energy and, if not installed and used in accordance with the instructions, may cause harmful interference to radio communications.

However, there is no guarantee that interference will not occur in a particular installation. If this equipment does cause harmful interference to radio or television reception, which can be determined by turning the equipment on and off, the user is encouraged to try to correct the interference by one or more of the following measures:

- Reorient or relocate the receiving antenna.
- Increase the separation between the equipment and receiver.
- Connect the equipment into an outlet on a circuit different from that to which the receiver is connected.
- Consult the dealer or an experienced radio/TV technician for help.

CALIFORNIA PROPOSITION 65

WARNING:

This product and substances that may become airborne from its use may contain chemicals, including lead, known to the State of California to cause cancer, birth defects, or other reproductive harm. ***Wash hands after handling.***

FCC RF Exposure Information and Statement

This equipment complies with FCC RF radiation exposure limits set forth for an uncontrolled environment. To maintain compliance with FCC RF exposure requirements, the user and installer should keep a minimum 20cm distance separation between the user's body and the device.

This device complies with part 15 of the FCC rules. Operation is subject to the following two conditions: (1) this device may not cause harmful interference, and (2) this device must accept any interference received, including interference that may cause undesired operation.

NOTE: The manufacturer is not responsible for any radio or TV interference caused by unauthorized modifications to this equipment. Such modifications could void the user's authority to operate the equipment.

NOTE: This equipment has been tested and found to comply with the limits for a Class B digital device, pursuant to part 15 of the FCC Rules. These limits are designed to provide reasonable protection against harmful interference in a residential installation. This equipment generates uses and can radiate radio frequency energy and, if not installed and used in accordance with the instructions, may cause harmful interference to radio communications. However, there is no guarantee that interference will not occur in a particular installation. If this equipment does cause harmful interference to radio or television reception, which can be determined by turning the equipment off and on, the user is encouraged to try to correct the interference by one or more of the following measures:

- Reorient or relocate the receiving antenna.
- Increase the separation between the equipment and receiver.
- Connect the equipment into an outlet on a circuit different from that to which the receiver is connected.
- Consult the dealer or an experienced radio/TV technician for help
- This device and its antenna(s) must not be co-located or operating in conjunction with any other antenna or transmitter.

**FRONT VIEW/
VUE DE AVANT/VISTA FRONTAL**

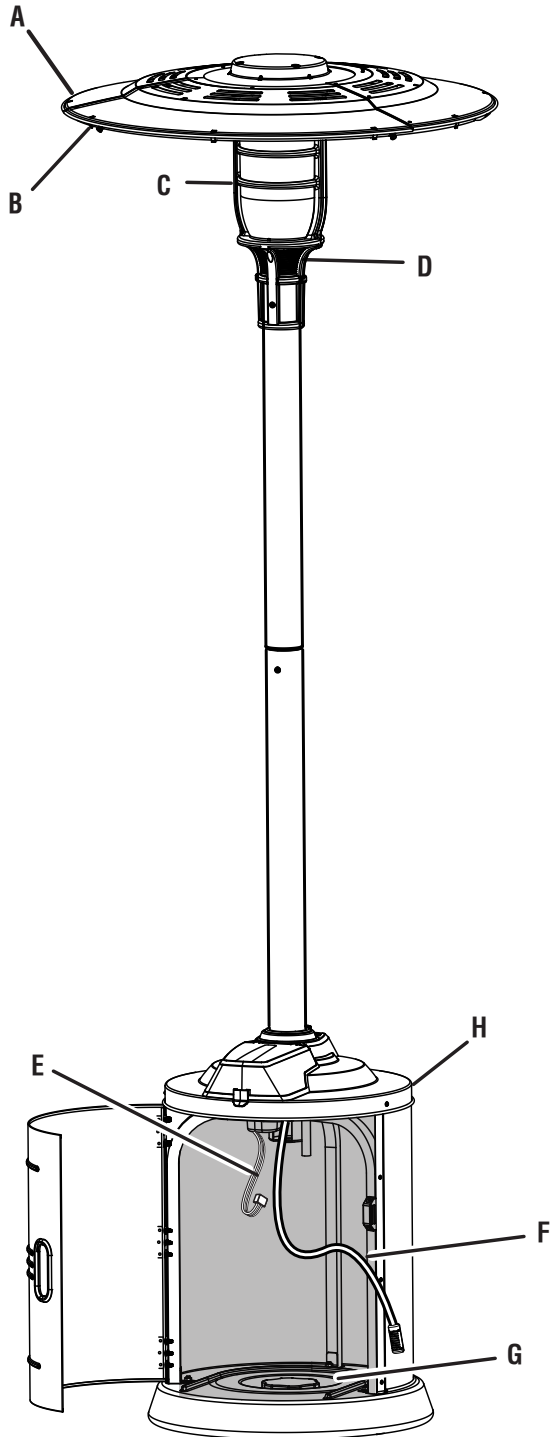

**BACK VIEW/
VUE ARRIÈRE/ VISTA POSTERIOR**

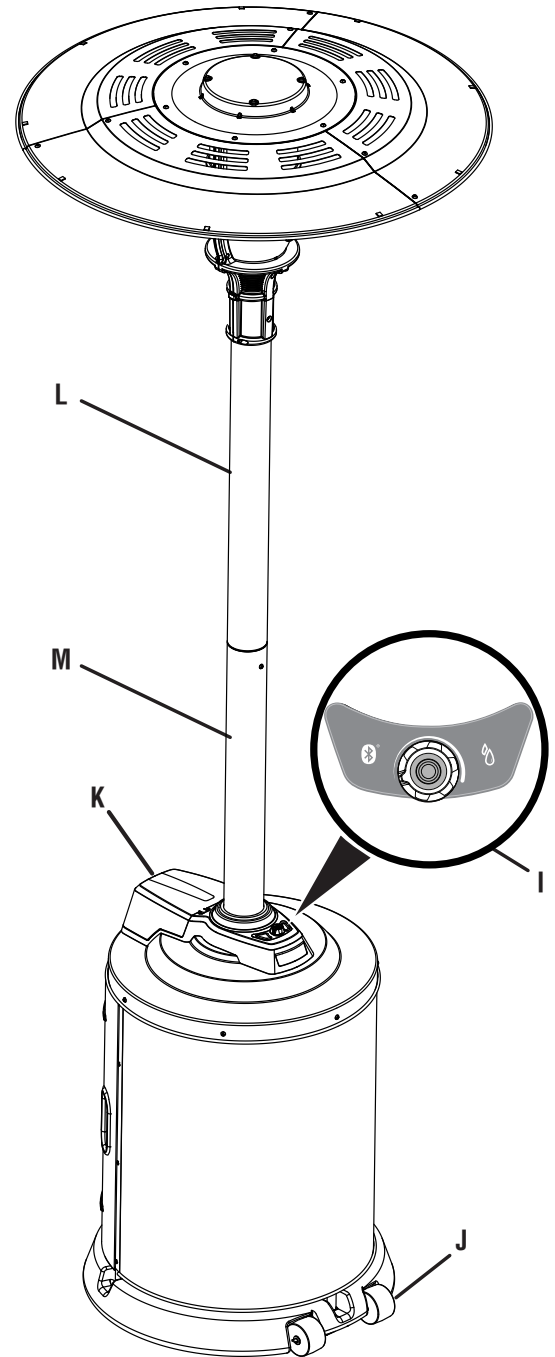

- A - Hood (chapeau, campana)
- B - Misting hose assembly (d'assemblage du boyau de vaporisation, conjunto de manguera de rociado)
- C - LED lighting (éclairage DEL, iluminación LED)
- D - BLUETOOTH® speaker (Haut-parleur, BLUETOOTH®, altavoces BLUETOOTH®)
- E - Wiring harness (câblage électrique, arnés de cableado)
- F - Water pickup tube (tube plongeur, tubo captador de agua)

- G - Bucket compartment (compartiment du seau, compartimiento para el cubo)
- H - Base assembly (assemblage de la base, conjunto de base)
- I - Control panel (panneau de commande, panel de control)
- J - Wheels (roues, ruedas)
- K - Battery pack compartment (compartiment de pile, compartimiento de la batería)
- L - Upper pole (poteau supérieur, poste superior)
- M - Lower pole (poteau inférieur, poste inferior)

Fig. 1

A - Phillips screwdriver (tournevis cruciforme, destornillador de cabeza Phillips)

B - Adjustable wrench (llave ajustable, clé à molette)

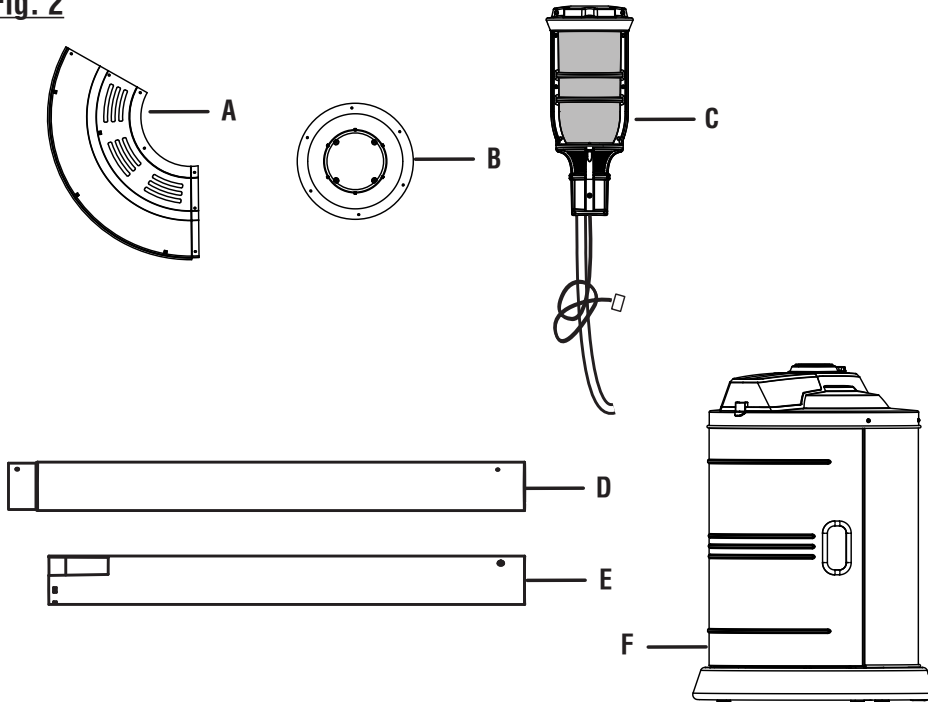
Fig. 2

A - Hood panels (panneaux du chapeau, paneles de la campana)

B - Hood cap (capuchon du chapeau, tapa de la campana)

C - Light assembly (assemblage d'éclairage, conjunto de luz)

D - Upper pole (poteau supérieur, poste superior)

E - Lower pole (poteau inférieur, poste inferior)

F - Base assembly (assemblage de la base, conjunto de base)

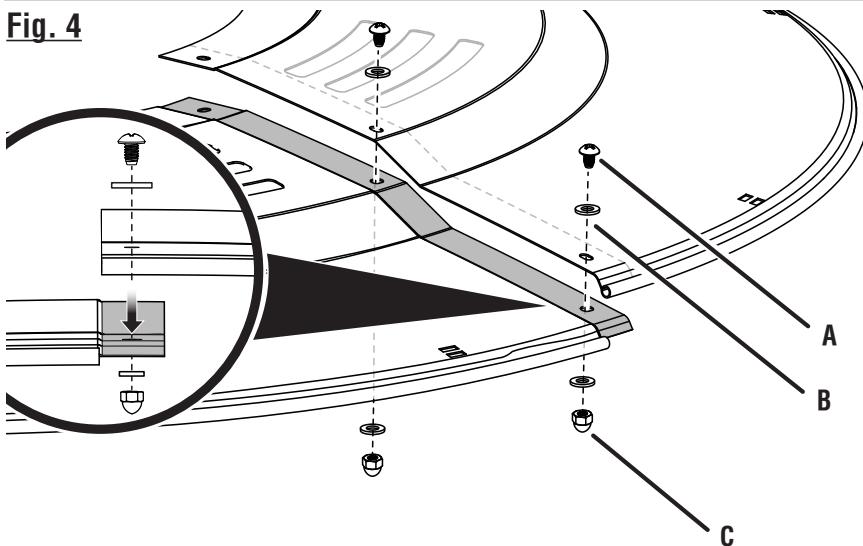
Fig. 4

A- Machine screw (**DD**) (vis à métaux, tornillo para metales)

B - Flat washer (**BB**) (rondelles plate, arandelas plana)

C - Cap nut (**CC**) (écrou du capuchon, tuerca de la tapa)

Fig. 3

HARDWARE BAG
(Items not to scale)
SAC DE QUINCAILLERIE
(non dessiné pour escalader)
BOLSA DE ACCESORIOS
(no dibujado para escalar)

| Key no./ Qty. | Description | |
|-------------------|---|--|
| AA (4) | Self-tapping screw (vis autotaraudeuse, tornillo autorroscante) | |
| BB (28) | Flat washer (rondelles plate, arandelas plana) | |
| CC (12) | Cap nut (écrou du capuchon, tuerca de la tapa) | |
| DD (16) | Machine screw (vis à métaux, tornillo para metales) | |
| EE (1) | Large flat washer (grande rondelle plate, arandela plana grande) | |
| FF (1) | Wing nut (écrous à oreilles, tuerca de mariposa) | |
| GG (9) | Spring clip (agrafe à ressort, sujetador de resorte) | |
| HH (1) | Misting hose assem- bly (assemblage de la boyau de vaporisation, conjunto de manguera de rociado) | |

Fig. 5

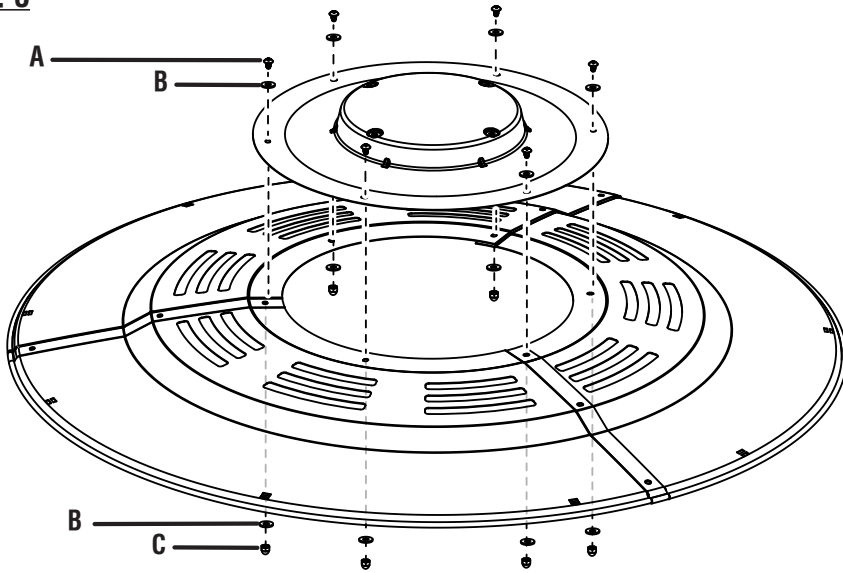

- A - Machine screw (**DD**) (vis à métaux, tornillo para metales)
- B - Flat washer (**BB**) (rondelles plate, arandelas plana)
- C - Cap nut (**CC**) (écrou du capuchon, tuerca de la tapa)

Fig. 6

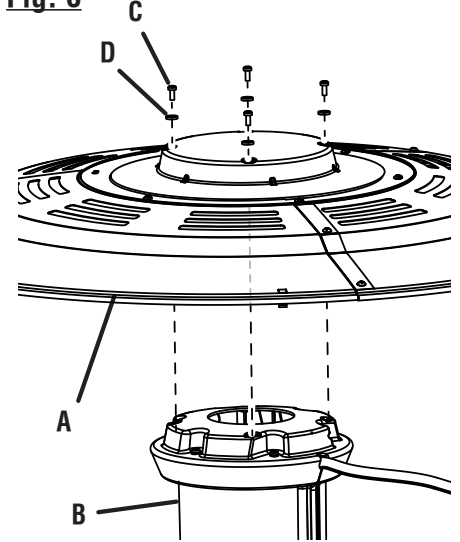

- A - Hood assembly (assemblage du chapeau conjunto de manguera)
- B - Light assembly (assemblage d'éclairage, conjunto de luz)
- C - Self-tapping screw (**AA**) (vis autotaraudeuse, tornillos roscadores)
- D - Flat washer (**BB**) (rondelles plate, arandelas plana)

Fig. 7

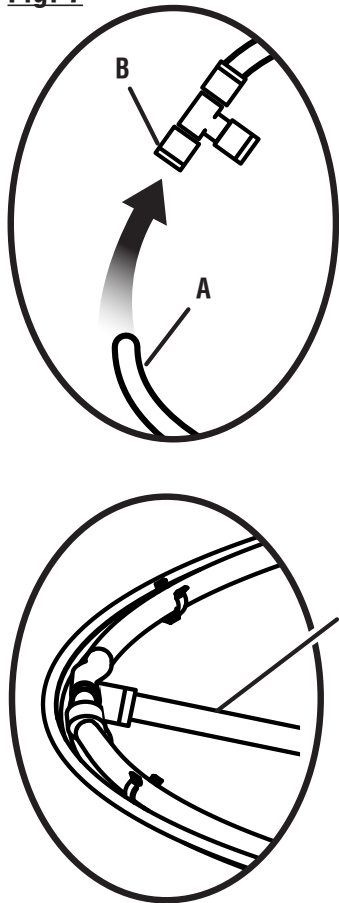

- A - Misting hose assembly (**HH**) (assemblage de la boyau de vaporisation, conjunto de manguera de rociado)
- B - T-connector (raccord en T, conector en T)
- C - Water tube (tube d'eau, tubo de agua)
- D - Spring clip (**GG**) (pince à ressort, sujetador de resorte)
- E - Misting nozzle (buses de vaporisation, boquillas para

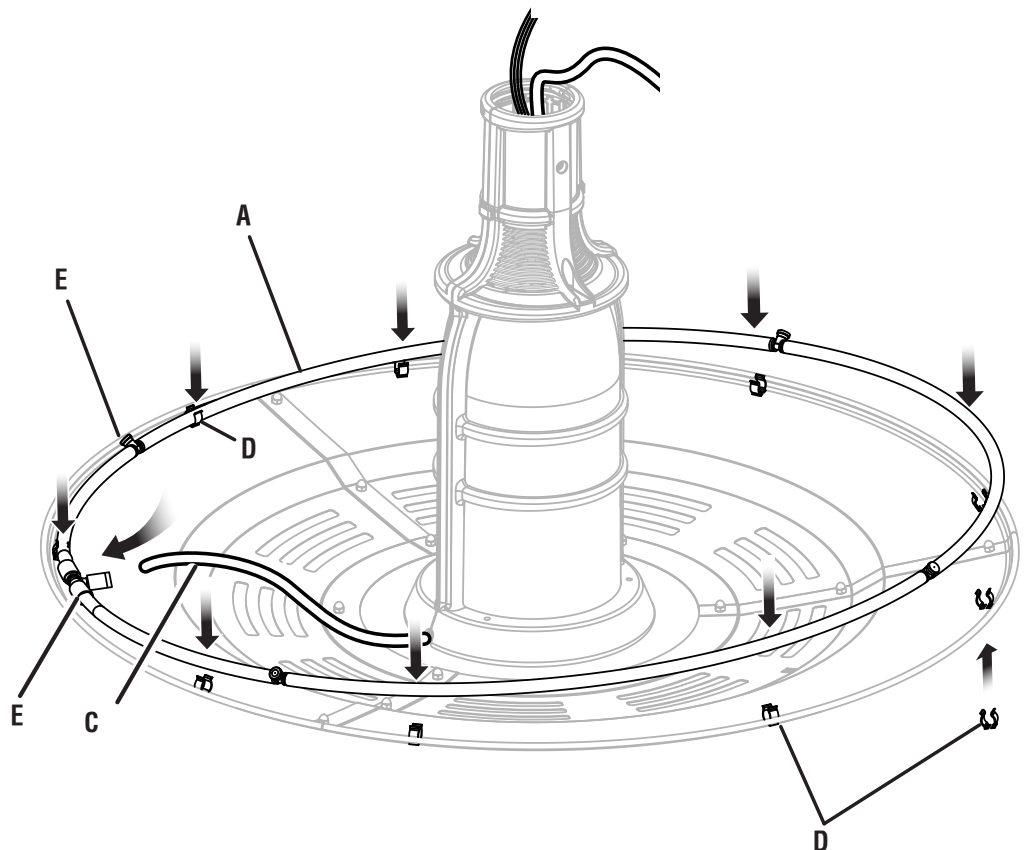
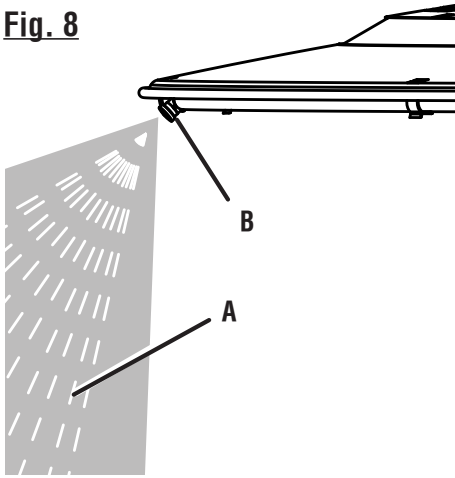
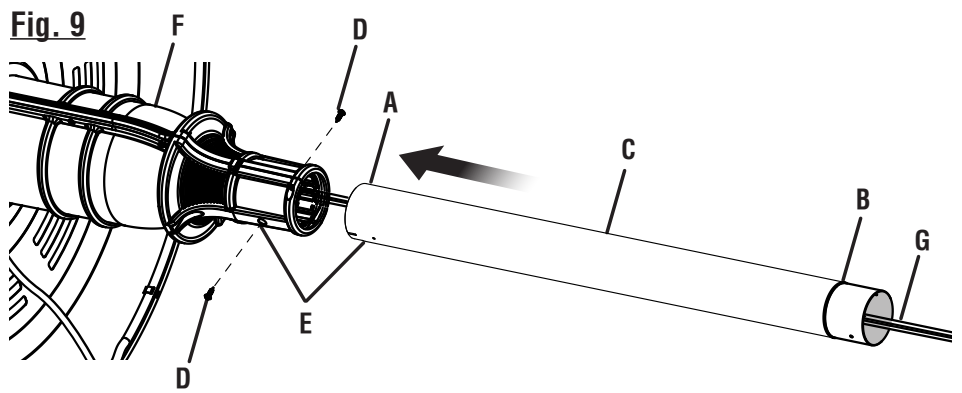

Fig. 8



- A - Proper mist pattern (modèle de brumisation adéquat, patrón de rociado adecuado)
- B - Proper spray nozzle orientation (orientation adéquate des buses de vaporisation, orientación de la boquilla pulverizadora adecuada)

Fig. 9



- A - End A (extrémité A, extremo A)
- B - End B (extrémité B, extremo B)
- C - Upper pole (poteau supérieur, poste superior)
- D - Machine screw (**DD**) (vis à métaux, tornillo para metales)
- E - Screw holes (trous de vis, tornillos de cada)
- F - Light assembly (assemblage d'éclairage, conjunto de luz)
- G - Water pickup tube and wiring harness (câblage électrique et le tube plongeur, arnés de cableado y el tubo captador de agua)

Fig. 10

**TOP VIEW OF BASE
VUE DE DESSUS DE LA BASE
VISTA DE SUPERIOR DE BASE**

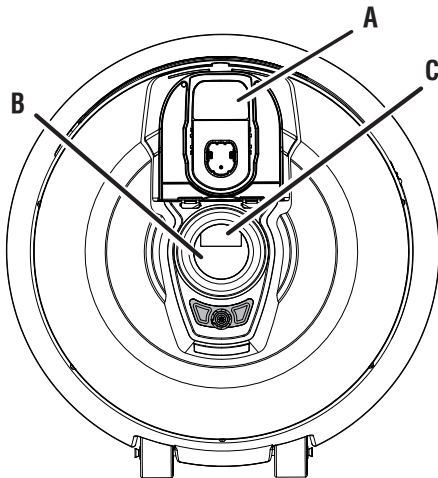

- A - Battery compartment (compartiment de pile, compartimiento para el baterías)
- B - Center hole (trou central, orificio central)
- C - Rectangular slot (fente rectangulaire, ranura rectangular)

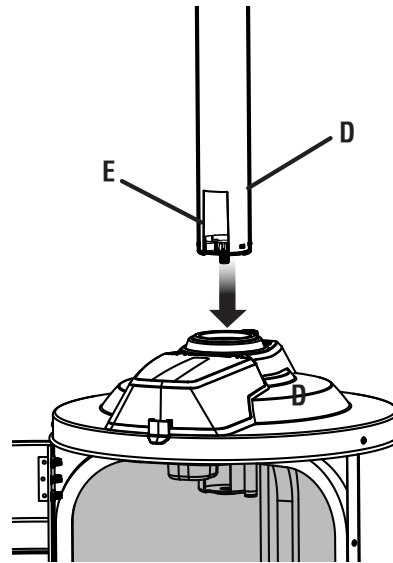

- D - Lower pole (poteau inférieur, poste inferior)
- E - Lower pole slot (fente du poteau inférieur, ranura del poste inferior)

Fig. 11

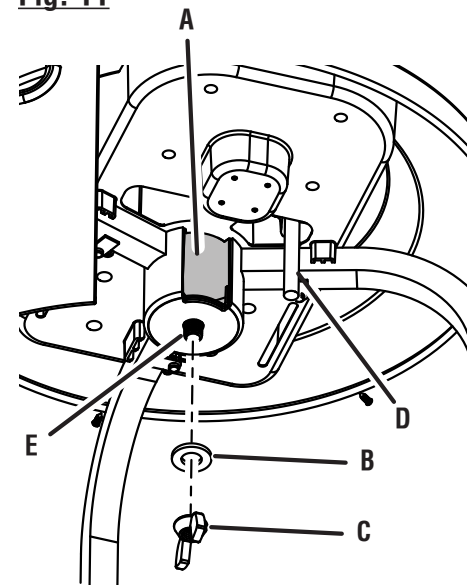

- A - Proper alignment of lower pole tab and rectangular slot of base (alignement correct de la languette du poteau inférieur et de la fente rectangulaire de la base, alineación adecuada de la lengüeta del poste inferior y la ranura rectangular de la base)
- B - Large flat washer (**EE**) (grand rondelles plate, arandelas plana grande)
- C - Wing nut (**FF**) (écrous à oreilles, tuerca de mariposa)
- D - Water tube (tube d'eau, tubo de agua)
- E - Bolt (boulon, perno)

Fig. 12

- A - Base assembly (assemblage de la base, conjunto de base)
- B - Door (port, puertas)
- C - Plastic cap (capuchon en plastique, tapa del plástico)
- D - Play sand (not included) (sable pour terrain de jeux, arena para jugar)

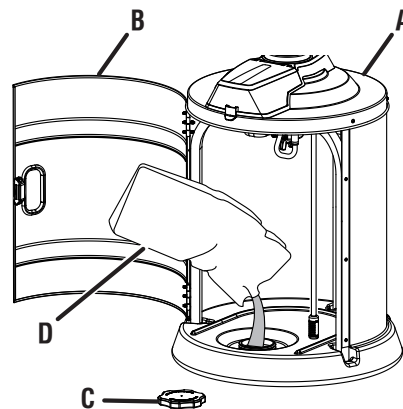
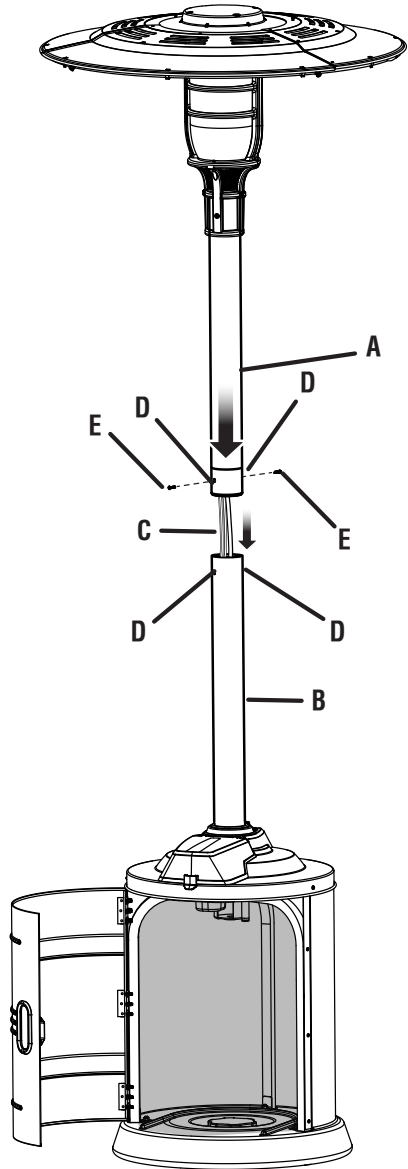
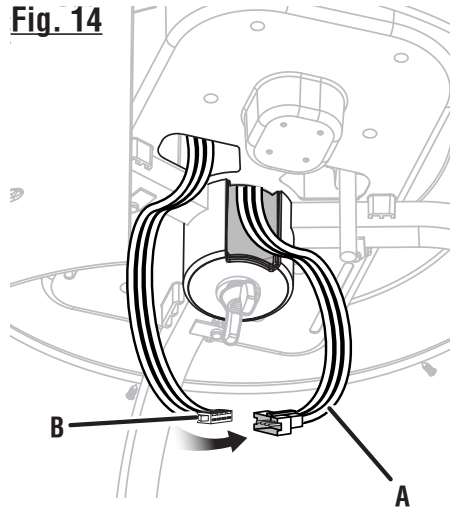

Fig. 13



- A - Upper pole (poteau supérieur, poste superior)
- B - Lower pole (poteau inférieur, poste inferior)
- C - Wiring harness and water pickup tube (câblage électrique et le tube plongeur, arnés de cableado y el tubo captador de agua)
- D - Screw holes (trous de vis, tornillos de cada)
- E - Machine screws (DD) (vis à métaux, tornillo para metales)

Fig. 14



- A - Wiring harness (câblage électrique, arnés de cableado)
- B - Wiring harness connector (raccord du câblage électrique, conector del arnés de cableado)

Fig. 15

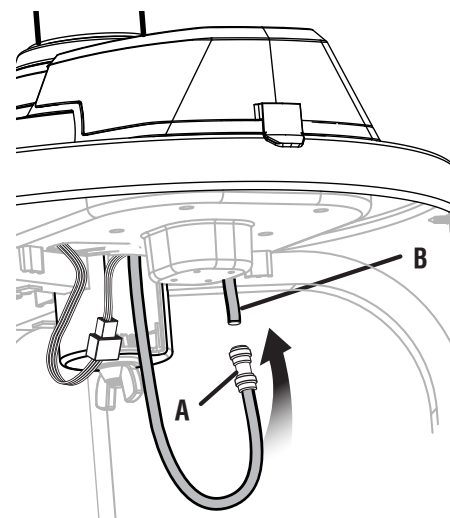

- A - Coupler (raccord, acoplador)
- B - Water tube (tube d'eau, tubo de agua)

Fig. 16

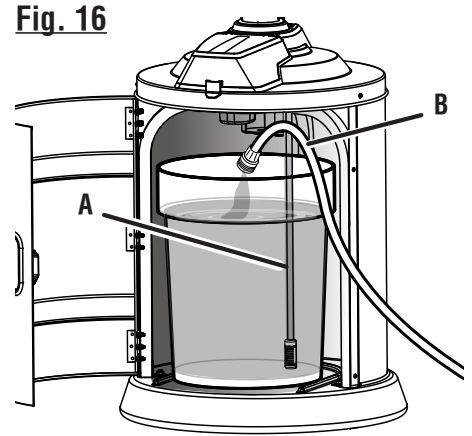

- A - Water pick up tube (tube plongeur, tubo captador)
- B - Garden hose (boyau d'arrosage, manguera de jardín)

Fig. 17

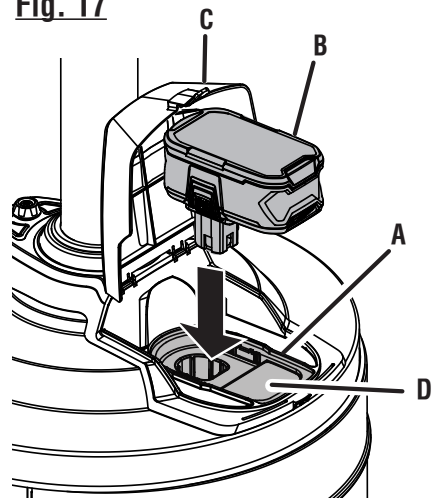

- A - Battery compartment (compartiment de pile, compartimento de la batería)
- B - Battery pack (bloc-pile, paquete de batería)
- C - Battery compartment cover (couverture du compartiment de pile, cubierta del compartimento de la batería)
- D - Data label location (emplacement de l'étiquette de données, ubicación de la etiqueta de datos)

Fig. 18

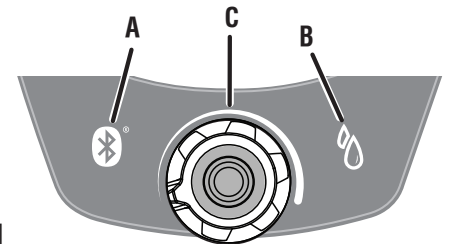

- A - BLUETOOTH® speaker ON/OFF [interrupteur de ON/OFF (MARCHE/ARRÊT) du haut-parleur BLUETOOTH®, altavoz BLUETOOTH® ON/OFF (ENCENDIDO/APAGADO)]
- B - Misting ON/OFF [vaporisation ON/OFF (MARCHE/ARRÊT), rociado ON/OFF (ENCENDIDO/APAGADO)]
- C - LED lighting ON/OFF and brightness adjustment [témoin DEL d'allumage ON/OFF (MARCHE/ARRÊT) et d'intensité d'éclairage, iluminación LED ON/OFF (ENCENDIDO/APAGADO) y ajuste de brillo]

Fig. 19

NE PAS BASCULER EXCESSIVEMENT L'APPAREIL!

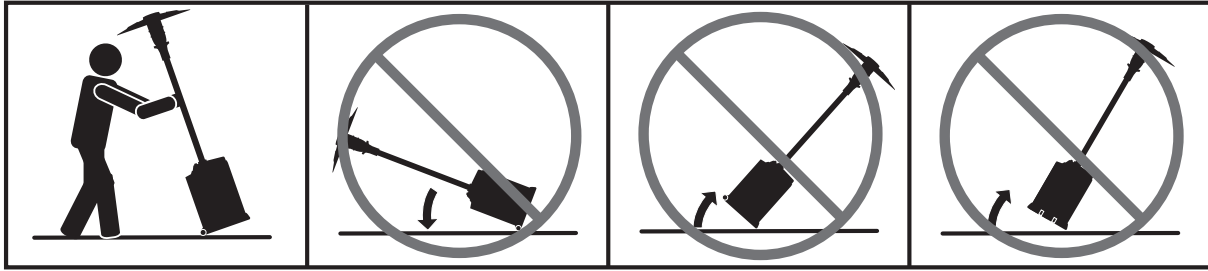
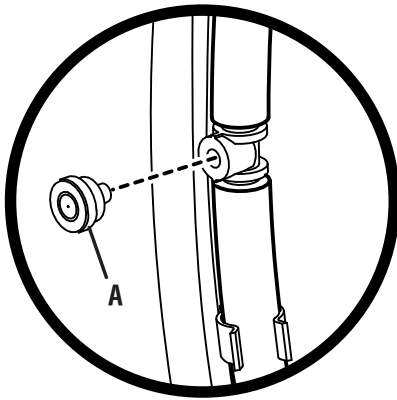
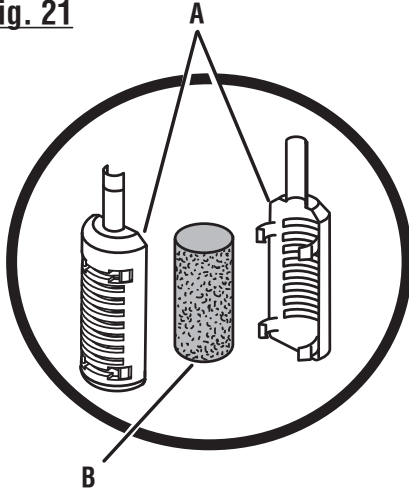

Fig. 20



A - Brass nozzle (buse en laiton, boquillas de latón)

Fig. 21



A - Filter cover (couvercle filtre, cubierta filtro)
B - Filter (filtre, filtro)

Fig. 22

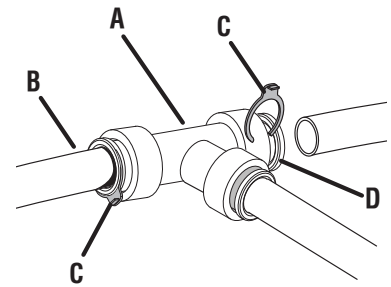

A - T-connector (raccord en T, conector en T)
B - Water tube (tube d'eau, tubo de agua)
C - Blue ring (anneau bleu, anillo azul)
D - Collar (anneau, collarin)



18V MUSIC, MISTING, AND LIGHT TOWER

**TOUR DE BRUMISATION, MUSICAL ET
D'ÉCLAIRAGE 18 V**

**TORRE DE ROCIADO CON
MÚSICA Y LUZ 18 V**

**OPERATOR'S MANUAL
MANUEL D'UTILISATION
MANUAL DEL OPERADOR**

MLT0180

To request service, purchase replacement parts,
and/or obtain Customer Support:

Visit **www.arcticcove.com** or call **1-877-297-8911**

If any parts or accessories are damaged or missing,
do not return this product to the store. Call **1-877-297-8911** for immediate service.

Please obtain your model and serial number from the product data plate.

MODEL NUMBER _____ SERIAL NUMBER _____

Pour faire une demande de réparations ou obtenir des pièces de rechange
et / ou obtenir un soutien le Service à la clientèle :

Visiter **www.arcticcove.com** ou en téléphonant au **1-877-297-8911**

Si des pièces ou accessoires sont manquantes ou endommagées, ne pas retourner
ce produit au magasin. Appeler immédiatement au **1-877-297-8911** pour obtenir de l'aide.

Inscrire les numéros de modèle et de série inscrits sur la plaque d'identification du produit

NUMÉRO DE MODÈLE _____ NUMÉRO DE SÉRIE _____

Para obtener servicio, comprar piezas de repuesto
y/o obtener Servicio al Consumidor:

Visite **www.arcticcove.com** o llame al **1-877-297-8911**

Si hay alguna pieza ou accesorios dañada o faltante, no devuelva este producto a la tienda.
Llame al **1-877-297-8911** para servicio técnico inmediato.

Obtenga su modelo y número de serie de la placa de datos del producto.

NÚMERO DE MODELO _____ NÚMERO DE SERIE _____

ONE WORLD TECHNOLOGIES, INC.

1428 Pearman Dairy Road, Anderson, SC 29625

Phone 1-877-297-8911

USA, Teléfono 1-877-297-8911

www.arcticcove.com